

EVINRUDE®
E-TEC®



G2 Operators Guide

Includes Safety, Use, and Maintenance
Information

**115 H.O., 140 HP, 150
HP(1.865L Inline 3-Cylinder)**

⚠ WARNING

Read this Manual thoroughly. It contains important safety information.
Minimum recommended operator age: 16 years old. Keep this Operator's
Manual in the boat.



Version -

CALIFORNIA PROPOSITION 65 WARNING

WARNING

This product contains or emits chemicals known to the state of California to cause cancer and birth defects or other reproductive harm.

All rights reserved. No parts of this Manual may be reproduced in any form without the prior written permission of Bombardier Recreational Products Inc.
©Bombardier Recreational Products Inc. (BRP) 2019

TM®Trademarks of BRP or its affiliates.

This document contains the trademarks of the following companies:

2+4 Fuel Conditioner® is a registered trademark of BRP.

E-TEC® is a registered trademark of BRP.

Evinrude® is a registered trademark of BRP.

i-Command™ is a trademark of BRP.

ICON™ is a trademark of BRP.

ICON II™ is a trademark of BRP.

iTrim™ is a trademark of BRP.

S.A.F.E.™ is a trademark of BRP.

SystemCheck® is a registered trademark of BRP.

XD100™ is a trademark of .

XD50™ is a trademark of BRP.

FEATURES AT A GLANCE

Easy to Own and Operate

- 5-Year* Engine Warranty
- 5-Year Non-Declining Corrosion Warranty
- 5-Years or 500 hours No Scheduled Dealer Maintenance (Normal Recreational Use)
- No Operational Break-In Procedure
- Easy Starts (no choking or priming)
- Digital Engine Management
- Self Flushing Cooling System
- Long Term Storage Design
- Simplified Winterization Procedure
- Digital Diagnostics
- Low Oil Usage

Durable and Reliable

- Full Corrosion Protection
- *Evinrude E-TEC®* Lubrication System
- Robust, Heavy-Duty Design
- Extra Capacity Water Pump
- Iridium Spark Plugs
- Vibration Isolated Electronics
- Beltless 30 Amp Charging System
- Stainless Steel Thermostat
- Nickel/Chrome-Faced Piston Rings
- Micro Finished Connecting Rods/Crankshaft

Cleaner and Quieter

- EPA Emissions Compliance
- European Union Emissions Compliance
- California 3-Star Emissions Compliance
- Sealed Fuel System
- Low Friction Design (No belts, cams, or oil scraping rings)
- Full Length Insulated Engine Covers
- Quiet Signature Sound
- Air Intake/Silencer
- Idle Air Bypass

TABLE OF CONTENTS

FEATURES AT A GLANCE	3
ABOUT THIS GUIDE	7

SAFETY INFORMATION

IMPORTANT SAFETY MESSAGES	10
Safety Measures — General	10
Safety Measures — Installation and Maintenance	11
PRODUCT REFERENCES, ILLUSTRATIONS AND SPECIFICATIONS	12
Owner's Identification	12
Model and Serial Numbers	12
Stolen Outboards	12
Technical Literature	12
DECLARATION OF CONFORMITY	13

USING YOUR EVINRUDE OUTBOARD

IMPORTANT ON-PRODUCT LABELS	16
Labels	16
Important On-Product Labels	16
Hang Tag	16
Manufacturing Date	17
Remote Control Labels	17
Component Identification-Starboard	18
Component Identification- Port	19
Component Identification- Starboard	20
Component Identification- Port	20
Component Identification- Front	21
2-STROKE ENGINE OIL REQUIREMENTS	23
Evinrude Oil Brands	23
Oiling System Information	23
Priming the Oil System	24
Fuel Requirements	24
OPERATION	28
Safety Information	28
Engine Starting and Stopping	28
Remote Controls — Evinrude ICON II Control System	31
Engine Monitoring	39
Special Operating Conditions	41
Transporting the Outboard	42
Pre-Ride Inspection	44
Aquatic Invasive Species (AIS)	46

EMISSIONS INFORMATION

ENGINE EMISSIONS INFORMATION	50
Manufacturer's Responsibility	50
Dealer's Responsibility	50
Owner Responsibility	50
EPA EMISSION REGULATIONS	51

INSPECTION SCHEDULE52
 Inspection Table53
 Engine Care Products54

MAINTENANCE

MAINTENANCE56
 Anodes56
 Fuses56
 Gearcase Lubricant Level.....56
 Outboard External Finish.....57
 Submerged Outboard57
 Storage.....57
 S.A.F.E. Reset60
 Emergency Start Procedure61

This page is intentionally blank

ABOUT THIS GUIDE

This Operator's Guide is an essential part of your *Evinrude® E-TEC®* outboard. It contains pertinent information which, if followed, will provide you with a thorough understanding needed for proper operation, maintenance, care, and—above all—safety. Safety is our first priority and it should be yours too. It is strongly recommended you read this Guide from cover to cover. The more you know and understand about your *Evinrude E-TEC* outboard, the greater the safety and pleasure you will get from using it. Following this recommendation will assure the completeness of the information essential to your safety, the safety of any passengers, and other water users.

This Operator's Guide identifies important safety messages.

Although the mere reading of such information does not eliminate the hazard, the understanding and application of the information will promote the correct use of your outboard engine.

Safety Alert Symbol

This is the Safety Alert symbol. It is used to alert you to potential personal injury hazards. Obey all safety messages that follow this symbol to avoid possible injury or death.

This Guide should be kept in a waterproof bag with the outboard at all times during operation. If the product ownership is transferred, this Guide should be forwarded to the new owners.

A responsible, educated boater will fully appreciate the pleasures of boating and will be a safe boater. Boating Safety Classes are conducted by the U.S. Coast Guard Auxiliary, the U.S. Power Squadron and some Red Cross Chapters. For information about

classes, call toll free 1-800-336-BOAT.

For additional information about boating safety and regulations, call:

- U.S. Coast Guard Boating Safety Hotline 1-800-368-5647.

Outside North America please contact your Dealer or distributor for details about boating safety.

This Operator's Guide uses the following signal words identifying important safety messages.

DANGER

Indicates a hazardous situation which, if not avoided, will result in death or serious injury.

WARNING

Indicates a hazardous situation which, if not avoided, could result in death or serious injury.

CAUTION

Indicates a hazardous situation which, if not avoided, could result in minor or moderate injury

NOTICE

Indicates an instruction which, if not followed, could severely damage engine components or other property.

ENVIRONMENTAL NOTE

A note which provides tips and behaviors related to protecting the environment.

IMPORTANT: Identifies information that will help with assembly and operation of the product.

This page is intentionally blank

SAFETY INFORMATION

IMPORTANT SAFETY MESSAGES

This Operator's Guide contains essential information to help prevent personal injury and damage to equipment. Safety messages appear throughout this Guide in the applicable section.

Be careful! Human error is caused by many factors: carelessness, fatigue, overload, pre-occupation, unfamiliarity of operator with the product, drugs and alcohol to name a few. Damage to your boat and outboard can be fixed in a short period of time, but injury or death, has a lasting effect.

WARNING

For your safety and the safety of others, follow all safety warnings and recommendations. Do not disregard any of the safety precautions and instructions. Anyone operating your boat should first read and understand this guide before they operate your boat and outboard.

Safety Measures — General

- To fully appreciate the pleasures, enjoyment and excitement of boating there are some basic rules that should be observed and followed by any boater. Some rules may be new to you and others may be common sense or obvious... irrespective, take them seriously!
- Be sure at least one of your passengers knows how to handle your boat in case of an emergency.
- All passengers should know the location of emergency equipment and how to use it.
- Know the marine traffic laws and obey them.
- All safety equipment and personal flotation devices must be in good condition and suitable for your type of boat. Always comply with the regulations that apply to your boat.
- Remember, gasoline fumes are flammable and explosive. Always adhere to the fueling procedure contained in this Operator's Guide and those given to you by the fueling station. Always verify fuel level before use and during the ride. Apply the principle of 1/3 fuel to destination, 1/3 back and 1/3 reserve fuel supply. Do not carry spare fuel or flammable liquids in any storage or engine compartments.
- Whenever running the engine, assure there is proper ventilation to avoid the accumulation of carbon monoxide (CO), which is odorless, colorless, and tasteless, and can lead to unconsciousness, brain damage, or death if inhaled in sufficient concentrations. CO accumulation can occur while docked, anchored, or underway, and in many confined areas such as the boat cabin, cockpit, swim platform, and heads. It can be worsened or caused by weather, mooring and operating conditions, and other boats. Avoid exhaust fumes from your engine or other boats, provide proper ventilation, shut off your engine when not needed, and be aware of the risk of back-drafting and conditions that create CO accumulation. In high concentrations, CO can be fatal within minutes. Lower concentrations are just as lethal over long periods of time.
- Avoid standing up or shifting weight suddenly in light weight boats.
- Keep your passengers seated in seats. The boat's bow, gunwale, transom and seat backs are not intended for use as seats.
- Insist on the use of personal flotation devices, approved by the U.S. Coast Guard, by all passengers when boating conditions are hazardous, and by children and non-swimmers at all times.
- Proceed with caution and at very low speed in shallow water. Grounding or abrupt stops may result in personal injury or property

- damage. Also be alert for debris and objects in the water.
- Be familiar with the waters you are operating in. The gearcase of this outboard extends below the water surface and could potentially come in contact with underwater obstructions. Contact with underwater obstructions may result in loss of control and personal injury.
 - Respect no wake zones, rights of other water users and the environment. As the "skipper" and owner of a boat you are responsible for damage to other boats caused by the wake of your boat. Allow no one to throw refuse overboard.
 - Do not operate your boat if you are under the influence of drugs or alcohol.
 - High performance boats have a high power-to-weight ratio. If you are not experienced in the operation of a high performance boat, do not attempt to operate one at, or near, its top speed until you have gained that experience.
 - Become completely familiar with the control and operation of your boat and outboard before embarking on your first trip or taking on a passenger(s). If you have not had the opportunity to do so with your Dealer, practice driving in a suitable area and feel the response of each control. Be familiar with all controls before applying the throttle above idle speed. As the operator, you are in control and responsible for safe operation.
- horsepower indicated on the boat's capacity plate. Overpowering could result in loss of control. If your boat has no capacity plate, contact your Dealer or the boat's manufacturer.
- When replacement parts are required, use *Evinrude Genuine Parts* or parts with equivalent characteristics, including type, strength and material. Using sub-standard parts could result in injury or product malfunction.
 - Only perform service procedures which are detailed in this Operator's Guide. Attempting to perform maintenance or repair on your outboard if you are not familiar with the correct service and safety procedure could cause personal injury or death. Further information can be obtained from your authorized *Evinrude Genuine Parts Dealer*. In many instances proper tools and training are required for certain service or repair procedures.
 - Maintain your boat and engine in top condition at all times. Adhere to the .
 - Operate your boat and outboard prudently and have fun. Do not forget that all persons must assist other boaters in case of emergency.
 - Prevent injury from contact with rotating propeller; remove propeller before flushing or before performing any maintenance.

Safety Measures — Installation and Maintenance

- The outboard must be correctly installed. Failure to correctly install the outboard could result in serious injury, death or property damage. BRP recommends that your Dealer install your outboard to ensure proper installation.
- Do not overpower your boat by using an engine that exceeds the

PRODUCT REFERENCES, ILLUSTRATIONS AND SPECIFICATIONS

BRP reserves the right to make changes at any time, without notice, to features, specifications and model availability, and to change any specification or part at any time without incurring any obligation to update older models. The information in the Guide is based on the latest specifications available at the time of publication.

Photographs and illustrations used in this Guide might not depict actual models or equipment but are intended as representative views for reference only.

Certain features of systems discussed in this Guide might not be found on all models in all marketing areas.

Owner's Identification

United States and Canada — At the time of purchase, your Dealer will complete your outboard registration forms. Your portion provides proof of ownership and date of purchase.

Outside United States and Canada — See your dealer or distributor for details.

Model and Serial Numbers

The model and serial numbers appear on a plate attached to the stern bracket or swivel bracket. Record your outboard's:

Model Number:

Serial Number:

Purchase Date:

Ignition Key Number:

Stolen Outboards

United States and Canada — Report stolen outboards to your local dealer or distributor.

Outside United States and Canada — Report the theft to the Bombardier

Recreational Products distributor where the outboard was registered.

Technical Literature

BRP offers technical literature specifically for your outboard. A service manual, or an extra Operator's Guide can be purchased from your selling Dealer. For the name and location of the nearest *Evinrude* Dealer in the United States and Canada visit www.evinrude.com.

DECLARATION OF CONFORMITY

The EC Declaration of Conformity does not appear in this version of the Operator's Guide. Please refer to the printed version that was delivered with your engine.

This page is intentionally blank

USING YOUR *EVINRUDE* OUTBOARD

IMPORTANT ON-PRODUCT LABELS

This outboard comes with hang tags and labels containing important safety information about the operation of the outboard. Any person who operates this outboard should read and understand this safety information.

Labels

All outboards have the following labels attached:

Important On-Product Labels

The following symbols are used together to indicate "CAUTION: Read the engine's Operator's Guide before proceeding.



1. READ OPERATOR'S GUIDE LABEL



2. WARNING LABEL

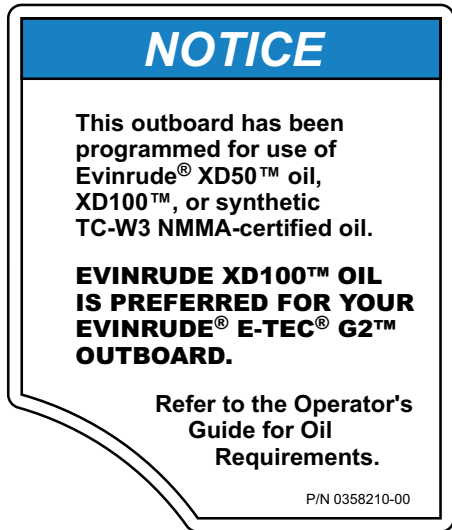

3. OIL USAGE NOTICE LABEL

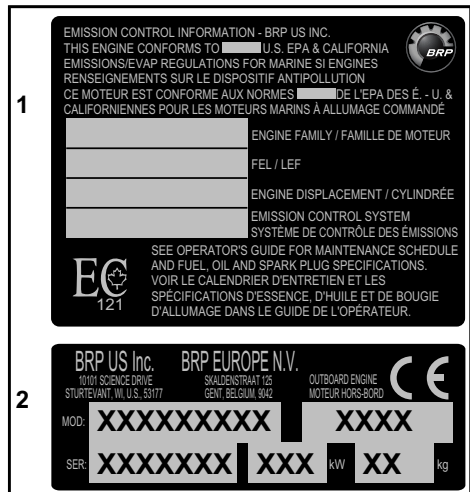

1. Emissions Control Label

2. Serial / Model Number Label

Hang Tag

All outboards are shipped with the following hang tag attached. This tag will be included with your pre-delivery items.

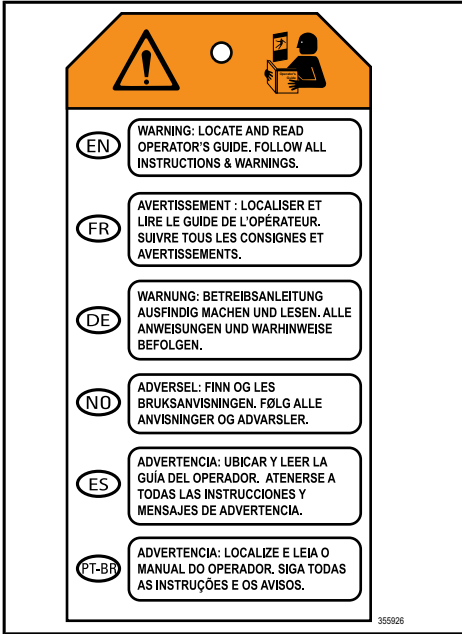

Manufacturing Date

A two-character code is used to indicate the month and year of manufacture, following the U. S. EPA model year naming convention.

- The first character is the year.
- The second character is the month (January = A, February = B, March = C, etc.).

For more information about Family Naming conventions, go to: <https://www.epa.gov/vehicle-and-engine-certification/information-about-family-naming-conventions-vehicles-and-engines>

Remote Control Labels

All mechanical remote controls have the following labels attached.

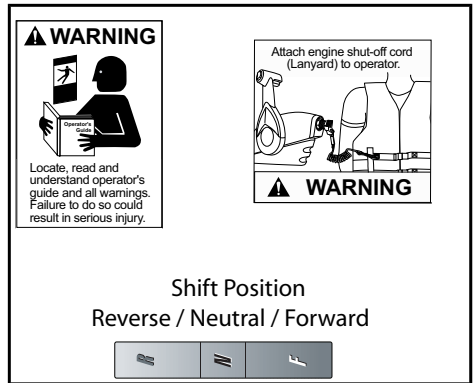

Component Identification-Starboard

NOTE: Some engine safety labels are not shown on illustrations. For information on engine safety labels, refer to **IMPORTANT ON PRODUCT LABELS**.

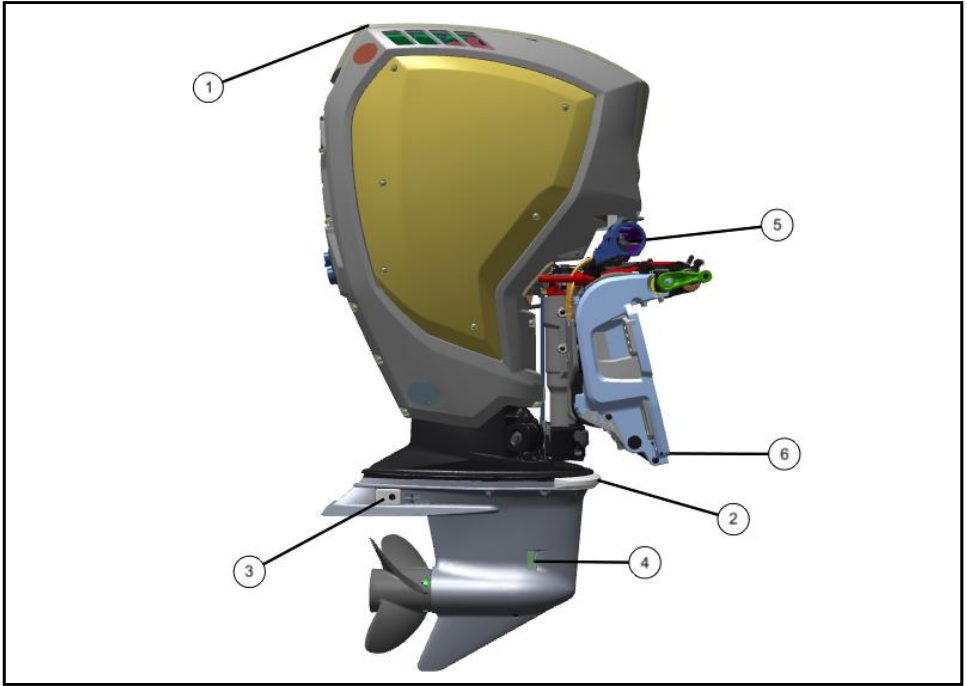

Item	Description	Item	Description
1	Air Inlet	4	Water Intake Screen
2	Anode, Gearcase, Front	5	Rigging Center Cable Entry
3	Anode, Gearcase, Rear	6	Anode, Midsection

Component Identification- Port

NOTE: Some engine safety labels are not shown on illustrations. For information on engine safety labels, refer to **IMPORTANT ON PRODUCT LABELS**.

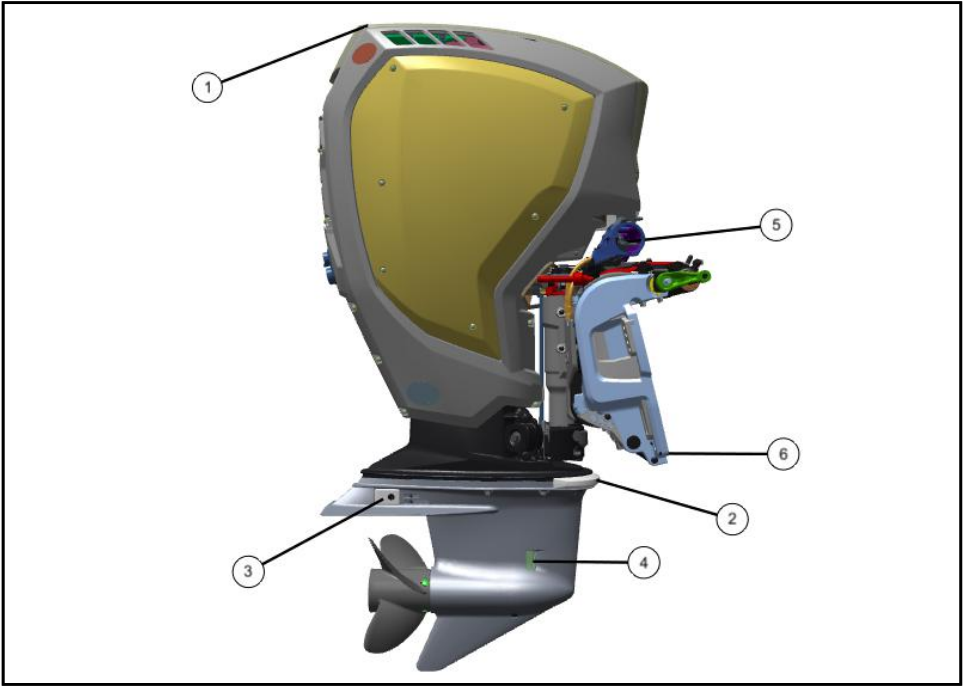

Item	Description	Item	Description
1	Trim/ Tilt Switch	4	Anode, Gearcase, Rear
2	Oil Cap	5	Water Intake Screen
3	Anode, Gearcase, Front	6	Anode, Midsection

Component Identification- Starboard

NOTE: Some engine safety labels are not shown on illustrations. For information on engine safety labels, refer to **IMPORTANT ON PRODUCT LABELS**.

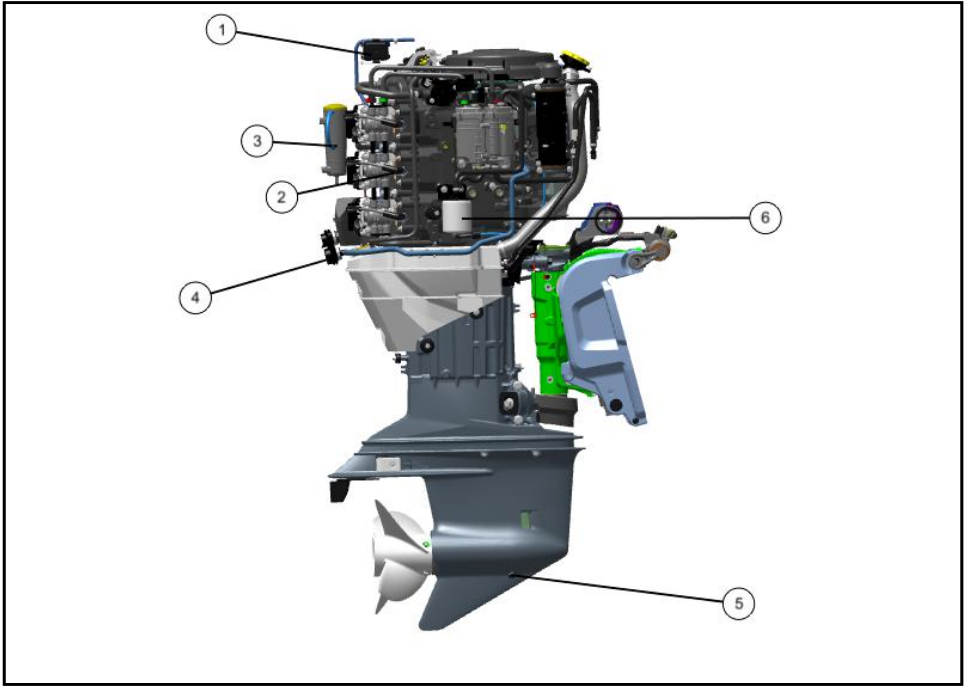

Item	Description	Item	Description
1	Fuse Box	4	Water Pump Overboard Indicator
2	Spark Plug	5	Gearcase Oil Drain Plug
3	Gearcase Oil Reservoir (Check Level)	6	Spin On Fuel Filter

Component Identification- Port

NOTE: Some engine safety labels are not shown on illustrations. For information on engine safety labels, refer to **IMPORTANT ON PRODUCT LABELS**.

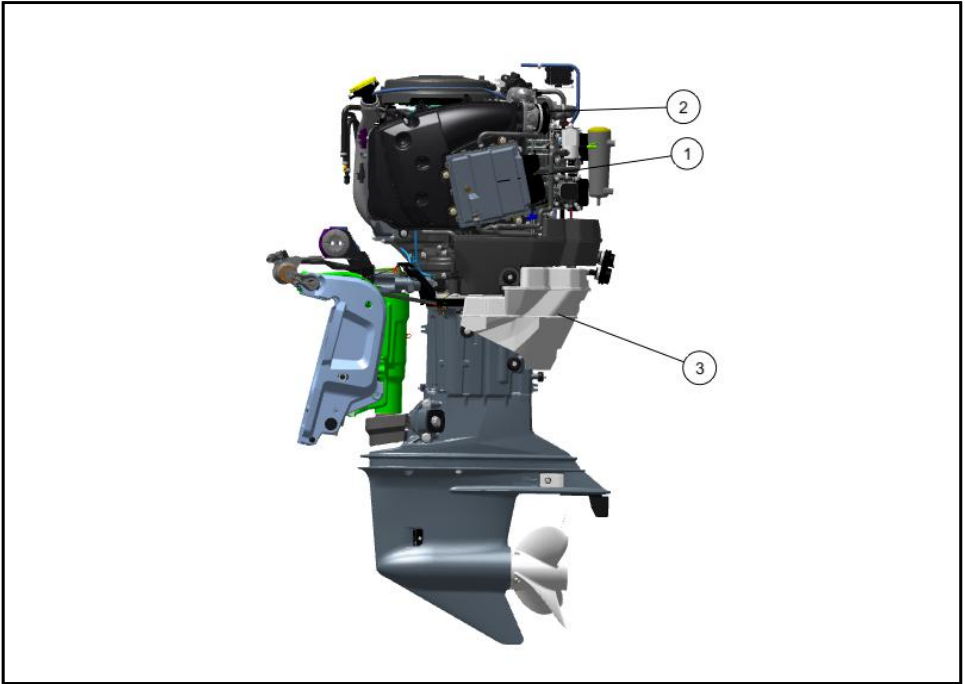

Item	Description	Item	Description
1	EMM (Engine Management Module)	3	Oil Tank
2	Air Inlet		

Component Identification- Front

NOTE: Some engine safety labels are not shown on illustrations. For information on engine safety labels, refer to **IMPORTANT ON PRODUCT LABELS**.

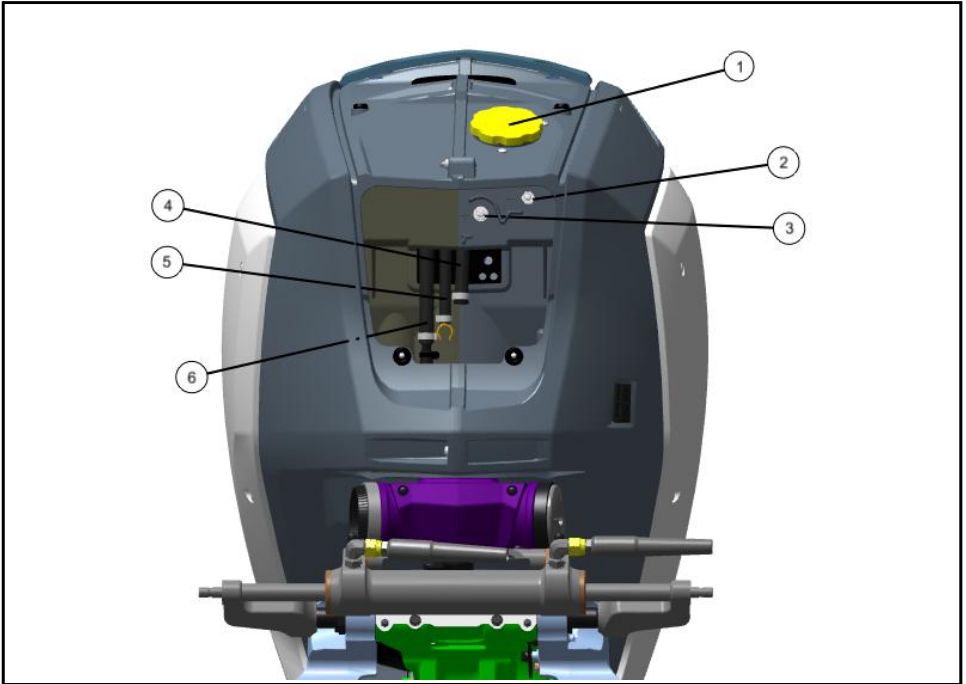

Item	Description	Item	Description
1	Oil Fill Cap	4	Fresh Water Flush Connection (If Equipped)
2	Negative (-) Battery Post	5	Oil Supply
3	Positive (+) Battery Post	6	Fuel Supply

2-STROKE ENGINE OIL REQUIREMENTS

NOTICE

When operating in conditions under 32°F (0°C), Evinrude XPS Marine XD100™ oil must be used.

Evinrude Oil Brands

Evinrude XPS Marine XD 2-stroke outboard oils are formulated to give best engine performance while controlling piston and combustion chamber deposits, providing superior lubrication, and ensuring maximum spark plug life.

The following 2-stroke outboard oils are recommended for use in your *Evinrude E-TEC* outboard:

- Evinrude XPS Marine XD100™ Direct Injection Oil
- Evinrude XPS Marine XD50™ 2-Stroke Oil
- Synthetic TC-W3 NMMA-certified oil

Evinrude XPS Marine XD100™ oil is preferred for your *Evinrude E-TEC* outboard. This synthetic formula oil provides uncompromised lubrication and superior performance, even in extreme conditions especially in cold temperatures down to 0°F (-17°C).

NOTICE

DO NOT add automotive type 4-stroke oils to 2-stroke engine oil tank(s). Do not add oil to the fuel.

Failure to follow oil specifications could void the engine warranty if a lubrication-related failure occurs.

Oiling System Information

If a “LOW OIL” warning occurs, you have a limited amount of time of normal operation before running out of oil. Refill the oil tank with approved oil as soon as possible.

Refer to **ENGINE MONITORING**.

To check oil level:

- Trim the outboard to the vertical position.
- Use a digital display or gauge to check the oil tank level.

Always “top off” your oil tank prior to prolonged usage or long trips. You may want to keep an extra supply of outboard oil in the boat.

New outboards are programmed to use additional oil during the first two hours of operation above 2000 RPM.

If you run the oil tank empty, REFILL the oil tank and prime the oil system before using the engine. Refer to **FILLING THE ON-ENGINE OIL TANK** and **PRIMING THE OIL SYSTEM**.

If an accessory remote oil tank is installed and the oil hose is disconnected for any reason, seal it to prevent spillage. Install a cap on the hose fitting to prevent contamination.

Oil Tank Capacity

The on-engine oil tank capacity is 1.9 gallons (7.2 Liters)

Optional Remote Oil Tank

The following optional accessory remote oil tank kits are available:

- 1.8 gallons (6.8 liters)
- 3.0 gallons (11.3 liters)
- An oil tank pick-up kit is also available for the 10 gallon (37.8 liters) capacity oil tank.

Install the optional remote oil tank following the instructions provided with the unit.

Filling the On Engine Oil Tank

1. Remove the top cap of the engine cover.
2. Remove the oil fill cap.
3. Fill the oil tank with outboard lubricant. Oil capacity is 1.9 gallons (7.2 Liters).

- Replace the filler cap and tighten securely.

If you run the tank empty, you must prime the oil system before using the engine.

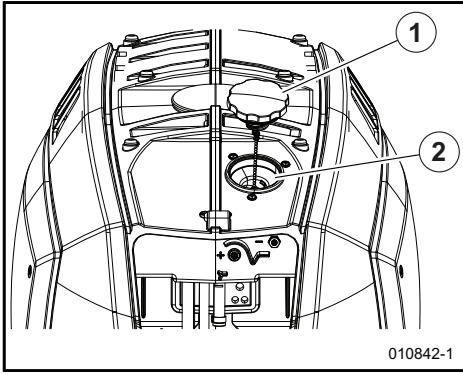

OIL FILL CAP

- Oil Fill Cap
- Oil Fill Tube

Tip

If the low engine oil light is illuminated, a full gallon of engine oil may be added to the reservoir.

Priming the Oil System

The oil system of *Evinrude E-TEC* outboards is primed at the factory.

Priming the oil system is only required if:

- The oil system is disassembled for service or parts replacement
- The oil tank is run out of oil

NOTE: If the oil tank is run out of oil, the *EMM* will activate SHUT DOWN mode and set Fault Code 33. See *NO OIL*.

After refilling an empty oil tank or servicing the oil system, air **MUST** be removed from the oil system before operating the outboard.

Prime the oil system by performing the *LONG-TERM STORAGE (WINTERIZATION)* — TWO times.

If available, *Evinrude Diagnostic* software v 6.1 or higher may be used to prime the oil system ONE time.

Fuel Requirements

⚠ WARNING

Gasoline is extremely flammable and highly explosive under certain conditions. Follow the instructions in this section explicitly. Improper handling of fuel could result in property damage, serious injury or death.

Leaking fuel is a fire and explosion hazard. All parts in the fuel system should be inspected frequently and replaced if signs of deterioration or leakage are found. Inspect the fuel system each time you refuel, each time you remove the engine cover and annually.

NOTICE

Always use fresh gasoline. Gasoline will oxidize; the result is loss of octane, volatile compounds, and the production of gum and varnish deposits which can damage the fuel system.

Fuel blending varies by country and region. Your outboard has been designed to operate using the recommended fuels; however, be aware of the following:

- The boat's fuel system may have different requirements regarding the use of alcohol fuels. Refer to the boat's owner guide.
- Alcohol blended fuels attract and hold moisture which may lead to fuel phase separation and can result in engine performance problems or engine damage.
- Use of fuel containing alcohol above the percentage specified by government regulation can result in the following problems in

outboard engines and fuel system components

- Vapor lock or fuel starvation
- Starting and operating difficulties
- Deterioration of rubber or plastic parts
- Corrosion of metal parts
- Damage to internal engine parts
- Have your dealer inspect for fuel leaks or other fuel system abnormalities if you suspect the presence of alcohol in gasoline exceeds the current government regulation limits.

Recommended Fuel

Use unleaded gasoline with an AKI (R+M)/2 octane rating of 87, or an RON octane rating of 90.

Biobutanol (Bu16) Fuel

Biobutanol is a four-carbon alcohol produced from renewable, plant-derived energy sources in a fermentation process similar to beer and wine production. Biobutanol delivers more renewable energy content than ethanol while remaining compatible with current vehicles, boats, and infrastructure. Biobutanol does not phase separate in the presence of water like ethanol and is less corrosive to fuel system components such as fuel tanks, fuel fitting, and fuel hoses.

Biobutanol blended fuel (either isobutanol or n-butanol) may be used in all *Evinrude* outboards. Use of biobutanol blended fuel will NOT void the warranty of *Evinrude* outboards

Biobutanol blended fuel (Bu16 — up to 16.1% by volume) has been approved for use by the *National Marine Manufacturers Association (NMMA)*.

Use in North America

NOTICE

Do NOT use fuel from fuel pumps labeled E85. Never experiment with other fuels.

The use of unleaded gasoline containing alcohol above the percentage specified by government regulations is not recommended. Use of fuel labeled E15 is prohibited by U.S. EPA Regulations.

Use of a boat mounted water separating fuel filter is strongly recommended.

Use In European Union

(2014/94/EU — on the deployment of alternative fuels infrastructure)

A European Standard provides harmonized labeling across Europe and thus effectively assists consumers in identifying the compatibility of the fuel supplied as a refueling point with an engine.

In the European Union, this *Evinrude E-TEC* engine is compatible with the following petrol-type fuel:



Use Outside of North America

The use of unleaded gasoline containing alcohol above the percentage specified by local government regulations is not recommended.

Use of a boat mounted water separating fuel filter is strongly recommended.

Fuel System Information

IMPORTANT: In the United States, the U.S. EPA requires low permeability fuel hose, fuel primer bulbs, portable fuel tanks and fuel caps to be used with outboard engines.

Fuel distribution hoses in the boat must deliver fuel at a specific flow rate. Minimum inside diameter of fuel hoses must be 3/8 in. (9 mm).

Fuel systems with built-in tanks, particularly those that include anti-siphon valves and filter/primer units, may have restrictions not allowing the engine fuel pump to deliver sufficient fuel under all conditions. This can result in a loss of performance. If a performance problem exists, see the *SERVICE NOTE*.

Fuel Hose Connections

If the fuel hose is disconnected for any reason, seal the hose and fitting to prevent spillage or contamination.

Connect the fuel hose to the 3/8 in. (9 mm) fuel fitting.

Fasten hose securely with the 18.5 mm clamp from owner's kit.

Fueling Procedure

WARNING

Fuel is flammable and explosive under certain conditions. Follow these instructions to ensure safety when handling fuel:

- Always work in a well ventilated area.
- Always turn off the engine before fueling.
- Never permit anyone other than an adult to refill the fuel tank.
- Do not smoke, or allow open flames, or sparks or use electrical devices such as cellular phones in the vicinity of a fuel leak or while fueling.
- When fueling, keep boat level.
- Remove portable fuel tanks from the boat before fueling.
- Fuel tank may be pressurized, turn cap slowly when opening.
- Do not overfill or top off the fuel tank and leave boat in the sun. As temperature increases, fuel expands and might overflow.
- To prevent fuel back-flow, fill the fuel tank slowly so air can escape from tank.
- Always wipe off any fuel spillage.

ENVIRONMENTAL NOTE

Dispose of fuel contaminated towels in an environmentally responsible manner, or according to local regulations.

Do NOT add 2-stroke engine oil to the fuel.

On A Trailer

1. Make sure the boat is level.
2. Slowly turn the fuel tank cap counterclockwise to remove it.
3. Insert the gas pump nozzle into the filler neck of the fuel tank and fill the fuel tank.

4. Stop filling immediately when the automatic shut-off feature of the gas pump handle activates.
5. Wait a moment before removing the gas pump nozzle from the filler neck. Do not retract the gas pump nozzle from the filler neck to top off the fuel tank.
6. Install the fuel tank cap and turn clockwise to fully tighten it.

In the Water

1. Turn off the engine.
2. Tie the boat securely to the fueling pier.
3. Do not allow anyone to remain in or on the boat.
4. Have a fire extinguisher close at hand.
5. Slowly turn the fuel tank cap counterclockwise to fully tighten.
6. Insert the gas pump nozzle into the filler neck of the fuel tank and fill the fuel tank.
7. Stop filling immediately when the automatic shut-off feature of the gas pump handle activates.
8. Wait a moment before removing the gas pump nozzle from the filler neck. Do not retract the gas pump nozzle from the filler neck to top off the fuel tank.
9. Install fuel tank cap and turn clockwise to fully tighten it.

Fuel Additives

NOTICE

Use of other fuel additives can result in poor performance or engine damage.

The only fuel additives approved for use in your *Evinrude E-TEC* outboard are:

- *Evinrude 2+4 Fuel Conditioner*®
- *Evinrude Fuel System Cleaner*

Evinrude 2 +4 Fuel Conditioner will help prevent gum and varnish deposits from forming in fuel system components and will remove moisture from the fuel system. It can be used

continuously and should be used during any period when the outboard is not being operated on a regular basis. Its use will reduce spark plug fouling, fuel system icing, and fuel system component deterioration.

Evinrude Fuel System Cleaner will help keep fuel injectors in optimal operating condition.

Fuel System Priming

If the outboard is run out of fuel, refill the fuel tank. Turn the key switch to the ON position to activate the fuel pump.

OPERATION

Safety Information

DANGER

Serious injury or death can result from contact with a rotating propeller or moving boat and outboard. Propeller blades can be sharp and the propeller can continue to turn even after the engine is off. Assure the engine propeller area is clear of people and objects before starting engine or operating the boat. Be alert of people in the water. Always shift the outboard to NEUTRAL and shut off the engine immediately when your boat is in an area where there might be people in the water.

DANGER

DO NOT run the engine indoors or without adequate ventilation or permit exhaust fumes to accumulate in confined areas. Engine exhaust contains carbon monoxide which, if inhaled, can cause serious brain damage or death.

WARNING

The engine cover is a machinery guard. DO NOT operate your outboard with the cover off unless you are performing maintenance. Be careful to keep hands, hair, and clothing clear of all moving parts. Contact with moving parts could cause injury.

WARNING

Be familiar with the waters you are operating in. The gearcase of this outboard extends below the water surface and could potentially come in contact with underwater obstructions. Contact with underwater obstructions may result in loss of control and personal injury.

Engine Starting and Stopping

Refer to the *PRE-RIDE INSPECTION*. Complete the inspection before using your *Evinrude E-TEC* outboard.

NOTICE

You **MUST** supply water to the engine before attempting to start it. Engine damage can occur quickly.

Engine Cut-Off Switch / Key Switch

A combination engine cut-off switch and key switch is a feature of *Evinrude* prewired remote controls and all *Evinrude* control wiring kits. Use of the engine cut-off switch feature is highly recommended on all boats.

Connect the clip to the engine cut-off switch/key switch.

If boat is equipped with a second station, connect the clip to the second station cut-off switch.

IMPORTANT: The second station clip **MUST** be installed. The outboard cannot be started if the second station clip is not in place.

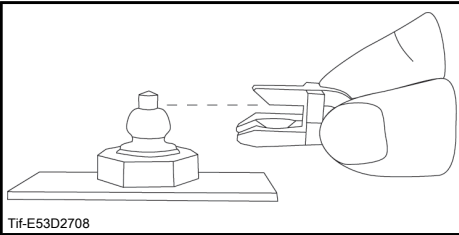

⚠ WARNING

Always use the tether cord when operating your boat to help prevent a runaway boat and reduce the risk of personal injury or death

In an emergency situation, the engine can be started without the clip installed on the key switch.

Follow the normal starting procedure.

Depress the engine cutoff switch and keep it depressed until safety is reached.

Reinstall a clip as soon as possible. The operator should always use the

clip and tether cord anytime the engine is running.

⚠ WARNING

Avoid knocking or pulling the clip off the engine cut-off switch during normal boating. Avoid bumping the key if operating without the clip on the switch. The resulting unexpected loss of forward motion can throw occupants forward, causing injury.

Keep the tether cord free from obstructions and entanglements. At each outing, test the system's operation. With the engine running, remove the clip from the switch by pulling the tether cord. If the engine does not stop running, see the Service Note.

IMPORTANT: Your engine cut-off switch can be effective only when in good working condition. At each outing, inspect clip and tether cord for cuts, breaks, or wear. Replace worn or damaged parts.

Snap the tether cord to a secure place on the operator's clothing or life vest — not where it might tear away instead of activating the engine cut-off switch.

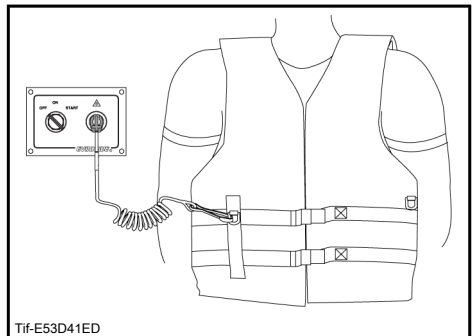

Disconnecting the clip and tether cord will stop the engine and prevent the boat from becoming a runaway if the driver moves beyond the range of the tether cord. If the tether cord is too

long, it can be shortened by knotting or looping it. DO NOT cut and re-tie the tether cord.

NOTICE

Carefully check the function of all control and engine systems before leaving the dock.

Move the remote control handle to NEUTRAL.

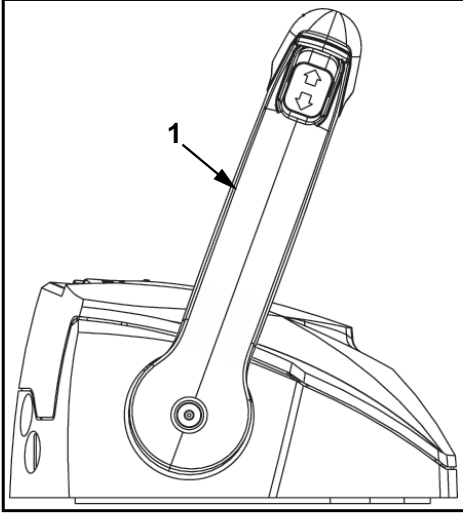

DO NOT advance the throttle before start-up. Advancing the throttle overrides the electronic idle control system.

If the outboard is started with the throttle advanced, the outboard will be in a safety mode.

It will not respond to throttle until the throttle is returned to slowest IDLE position.

After the engine starts, the engine management module (EMM) automatically increases idle speed slightly. Idle speed will decrease as the engine warms up.

Engine Starting

IMPORTANT: If equipped with Evinrude ICON II Remote Control System, refer to .

Turn the key switch to the ON position, then:

- **Single engine applications** — turn the key fully clockwise to the START position.
- **Multiple engine applications** — Push and hold the START button (s).

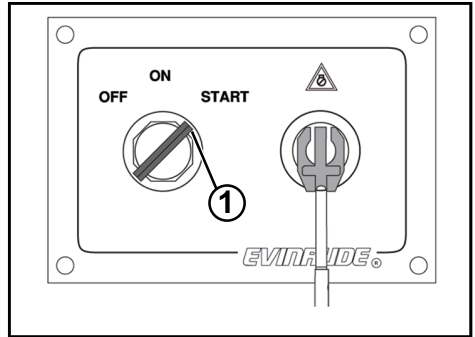

1. Key switch START position

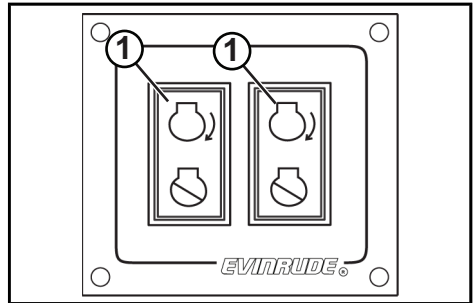

TYPICAL (DUAL ENGINE SHOWN)

1. Start buttons

Upon start-up, release the key or buttons.

If the engine did not start, release the key or button momentarily, then try again.

Each time the key switch is turned from OFF to ON, the warning system will self-test. Refer to **ENGINE MONITORING**.

If your outboard does not react normally to this starting procedure or if it fails to start, refer to .

After Engine Starts

The engine monitoring system will alert you of any abnormalities.

Engine Stopping

Move the control handle to the NEUTRAL position.

Multiple Engine Applications:

- Briefly push the STOP buttons.

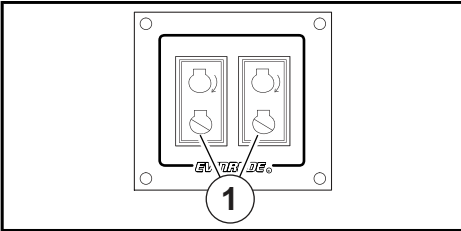

TYPICAL (DUAL ENGINE SHOWN)

1. Stop buttons

All Applications:

- Turn the key switch counterclockwise to the OFF position.

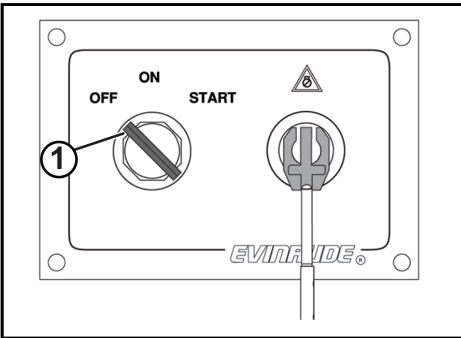

1. Key switch OFF position

Remove the key when the boat will be unattended.

Remote Controls — Evinrude ICON II Control System

IMPORTANT: For complete information about using Evinrude ICON II™

remote control systems, refer to the “Evinrude ICON II User’s Guide”.

Remote Control Selection

Evinrude ICON II is an intelligent, electronic shift and throttle control system for use with Evinrude E-TEC outboards. ICON II control systems are available for up to four-engine installations. The Evinrude ICON II control system supports dual station and “flying bridge” applications.

Evinrude ICON II Remote Control Features

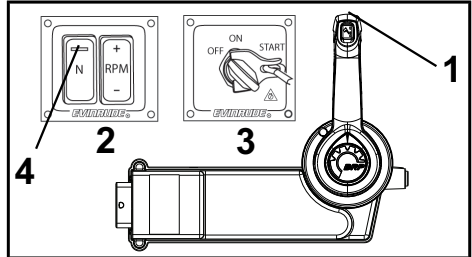

CONCEALED SIDE MOUNT EVINRUDE ICON II CONTROL

1. Trim/tilt switch
2. RPM switch panel (Optional)
3. OFF/ON/START switch
4. NEUTRAL Indicator LED (Optional)

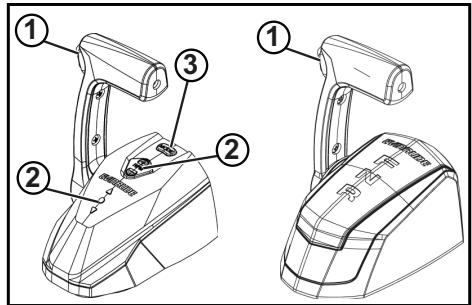

SINGLE BINNACLE EVINRUDE ICON II CONTROLS

1. Trim/tilt switch
2. Neutral button (full feature controls only)
3. Gear position indicator (full feature controls only)
4. RPM tune button (full feature controls only)

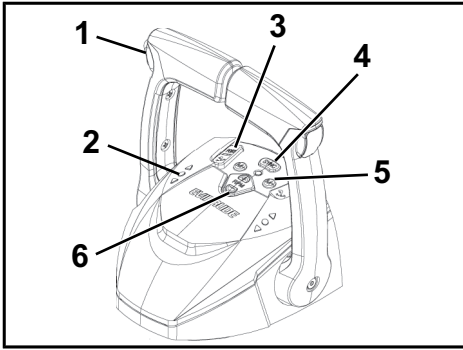

DUAL BINNACLE EVINRUDE ICON II CONTROL

1. Master Trim/tilt switch
2. Gear position indicators
3. Individual engine trim switches
4. SYNC button
5. Mode button
6. RPM Tune button

Shifting

With the engine running and the control handle in the NEUTRAL position, move the control handle forward or aft until the handle engages the forward or reverse gear detent.

Speed Control

After gear engagement, move the control handle slowly in the same direction to increase speed.

Press the RPM + or – button to fine tune engine speed up or down in 1% increments.

Engine Synchronization (Dual Binnacle Only)

Press the SYNC button to automatically synchronize the RPM of multiple engines. The SYNC button also transfers control of all engines to the port lever on the control.

NOTICE
SYNC will not match engine RPM under the following conditions:

- NEUTRAL throttle is active

- Port Engine speed is below 700 RPM
- Port Throttle setting is above 95%
- A critical fault is set

Evinrude Mechanical Controls

⚠ WARNING

If you choose a non-Evinrude remote control, it must have a start-in-gear prevention feature. This feature can prevent injuries resulting from unexpected boat movement when the engine starts.

Use of a mechanical remote control requires an accessory mechanical to digital shift and throttle converter.

IMPORTANT: When selecting the remote control system for your boat, specify Evinrude components. Evinrude controls incorporate safety and convenience features as:

- Start-in-gear prevention
- Plug-in compatibility with Evinrude Modular Wiring System (MWS).

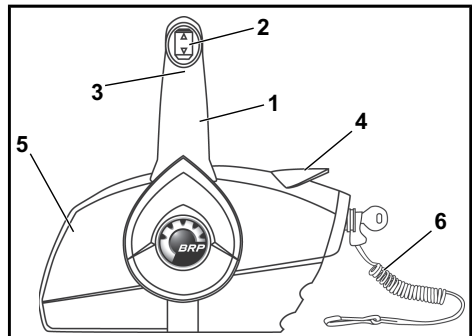

SIDE MOUNT CONTROL

1. Handle – shift and throttle
2. Trim/tilt switch (where equipped)
3. Neutral lock lever
4. Fast idle lever (warm-up)
5. Throttle friction adjusting screw
6. Engine cut-off switch clip and tether cord

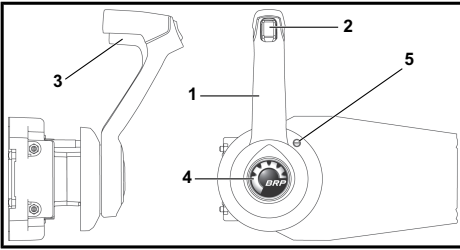

CONCEALED SIDE MOUNT CONTROL

1. Handle – shift and throttle
2. Trim/tilt switch (where equipped)
3. Neutral lock lever
4. Fast idle button (warm-up)
5. Throttle friction adjusting screw

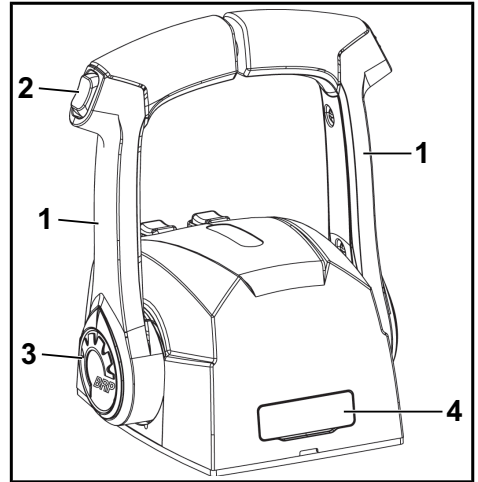

DUAL LEVER BINNACLE MOUNT CONTROL

1. Handle – shift and throttle
2. Trim/tilt switch (where equipped)
3. Fast idle button (warm-up)
4. Throttle friction adjusting screw (under cover)

Shifting

With the engine running and the control handle in the NEUTRAL position:

Side Mount Controls

Unlock the control handle by lifting the neutral lock lever on the hand grip. Move the control handle with a firm, quick motion, forward or aft until it engages the forward or reverse gear detent.

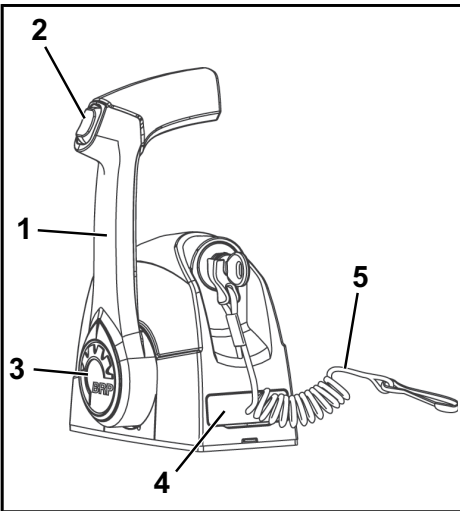

SINGLE LEVER BINNACLE MOUNT CONTROL

1. Handle – shift and throttle
2. Trim/tilt switch (where equipped)
3. Fast idle button (warm-up)
4. Throttle friction adjusting screw (under cover)
5. Engine cut-off switch clip and tether cord

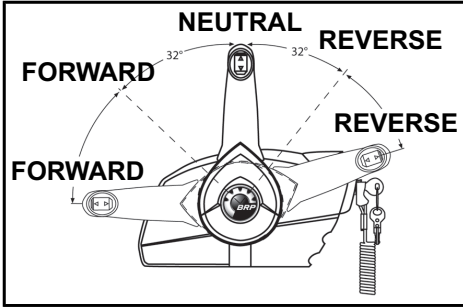

Binnacle Mount Controls

Move the control handle with a firm, quick motion, forward or aft until it engages the forward or reverse gear detent.

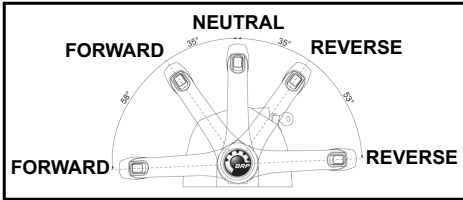

Fuel Economy

Fuel economy can vary depending on boat load, hull design, and throttle setting. When boat reaches top speed, throttle back from FULL SPEED to a lower throttle setting. You can save fuel with a minimal loss of speed.

If equipped, use the “fuel economy” feature of digital displays or gauges to optimize fuel consumption. Refer to the user’s guide for the digital display.

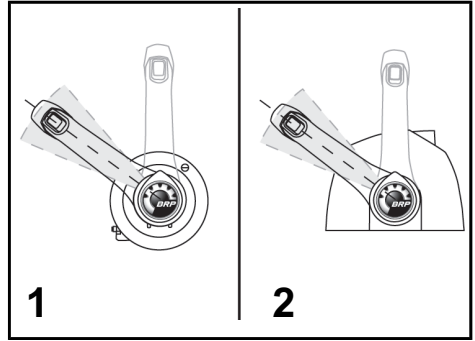

TYPICAL FUEL ECONOMY THROTTLE RANGE

1. Side mount control
2. Binnacle mount control

Power Trim and Tilt

The trim and tilt functions of *Evinrude E-TEC* outboards are controlled by the engine *EMM*.

IMPORTANT: Activating any trim button while the key switch is in the OFF position will briefly turn on the system. This will cause the electric fuel pump to run and the remote control and any displays or gauges to turn on. There will be a short delay before the trim system operates. This is

normal. The system will turn off after a few seconds of non-use.

⚠ WARNING

When operating in rough water or crossing a wake, excessive bow-up trim may result in the boat's bow suddenly rising skyward, possibly ejecting or otherwise seriously injuring occupants. Some boat/outboard/propeller combinations may encounter boat instability and/or high steering torque when operated at high speed at or near the outboard's trim range limits (full bow-up or bow-down). Boat stability and steering torque can also vary due to changing water conditions. If any adverse conditions occur, reduce throttle and/or adjust trim angle to maintain control. If you experience boat instability and/or high steering torque, see your Dealer to correct these conditions.

Some boats plow, or are difficult to plane, when operated in the lowest trim position. If your boat handles unsuitably when trimmed fully bow-down, adjust the trim.

⚠ WARNING

If the bow of the boat plows the water at high speeds, the boat may bow steer or spin suddenly, possibly ejecting or otherwise seriously injuring occupants.

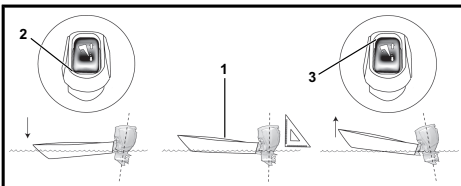

1. Parallel to the surface of the water
2. Trim switch UP
3. Trim switch DOWN

The boat should accelerate quickly, plane easily, and run parallel to the surface of the water at high speeds.

If trim position is too LOW the front of boat will be DOWN and push water.

If trim position is too HIGH the front of boat will be UP and bounce.

iTrim

Your outboard is equipped with iTrim™, a trim assist feature. By default, this feature is disabled from the factory.

Use the *Evinrude ICON-Touch*, *ICON CS* digital display, or other *Evinrude* approved devices to enable iTrim™. If your boat is not equipped with an *ICON™* digital display, your Dealer must use *Evinrude Diagnostic* software to enable this feature.

To activate the iTrim™, the key switch must be in the ON position. Use the trim/tilt switch to trim the engine to the full DOWN position.

During operation, the outboard will automatically trim up or down to an acceptable trim angle based on pre-programmed parameters.

IMPORTANT: Use of the trim/tilt switch to manually adjust the outboard trim angle will temporarily deactivate iTrim™.

To reactivate the iTrim™, use the trim/tilt switch to trim the engine to the full down position then bring the engine to idle speed.

Trim

In most operating conditions, it is recommended to trim the outboard to the full down position while accelerating. As the boat comes on plane, trim the outboard up for best performance.

Run the boat in the water to determine the best trim angle.

Over-trimming increases engine RPM while decreasing speed. The best trim setting is when the highest speed is achieved with the lowest engine RPM.

IMPORTANT: Weight distribution can affect the performance of the boat. Distribute weight evenly in the boat.

Trim Angle Adjustment

Use the trim/tilt switch to adjust the outboard position in the tilt range or trim range.

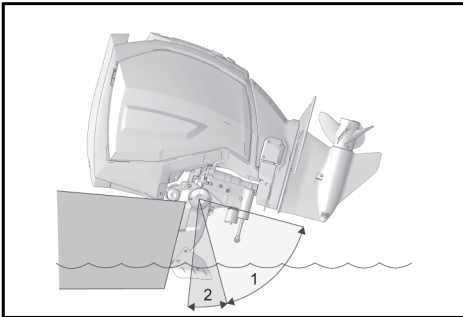

1. Tilt Range
2. Trim Range

Shallow Water

NOTICE

When operating a tilted outboard, do not run above a fast idle speed. Keep the water intakes submerged at all time to prevent the engine from overheating.

Tip

Throttling past idle with the engine tilted will cause the engine to automatically trim down into the water to help protect the engine.

Adjust the outboard position within the tilt range for shallow water operation.

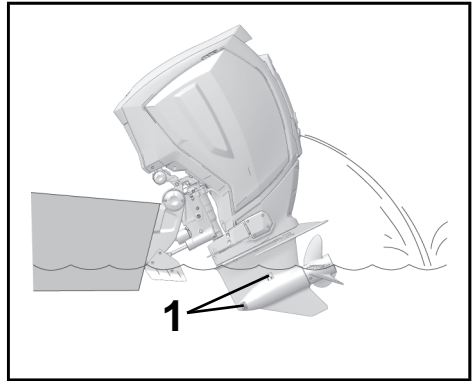

1. Water intakes

Tilt

The tilt range allows the operator to tilt the outboard for clearance when beaching, mooring, launching, or trailering.

Tilt Limit

See *ADJUSTMENTS*, if your outboard contacts the boat's motor well while tilting.

Tilt Support Lever

If you intend to leave the outboard tilted for a period of time, engage the tilt support lever.

1. Tilt the outboard UP using the trim/tilt switch.
2. Flip the tilt support lever down. Lower the outboard until the support lever rests solidly on the stern brackets.

Manual Release Valve

If needed, the outboard will tilt up or down manually, using the manual release valve.

⚠ WARNING

Keep everyone clear of a tilted outboard when backing out the manual release screw. The outboard could drop suddenly and forcibly. Be sure to tighten the manual release screw after manually repositioning the outboard. Tightening the screw also reactivates the outboard's impact protection and reverse thrust capability.

1. Turn the manual release screw counter-clockwise, slowly (about 3 1/2 turns), until it lightly contacts its retaining ring.
2. Reposition the outboard.
3. Tighten the manual release valve to hold the outboard in its new position.

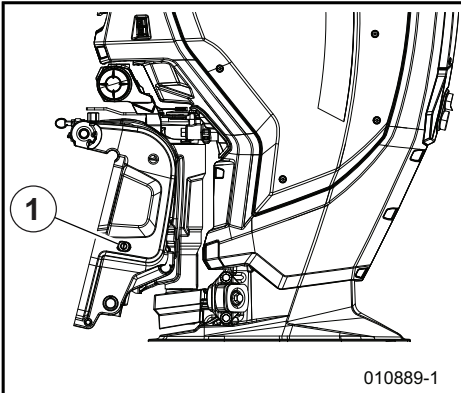

1. Manual Release Screw

Impact Damage Protection

⚠ WARNING

Any malfunction of the power trim and tilt unit could result in loss of shock absorber protection if an underwater obstruction is hit. Malfunction can also result in loss of reverse thrust capability. Correct fluid level must be maintained to ensure operation of the impact protection on this unit.

Your outboard has a shock absorption system designed to help withstand damage from impact with underwater objects at low to moderate speeds.

Such impacts can result in serious damage to your outboard or boat. Occupants can also be ejected or injured by falling against portions of the boat as a result of rapid deceleration following impacts.

When boating in unfamiliar, shallow, or debris-laden waters, seek information on safe boating areas and navigation hazards from a reliable local source. Reduce your speed and keep a sharp lookout!

IMPORTANT: Impact damage is NOT covered by the outboard warranty.

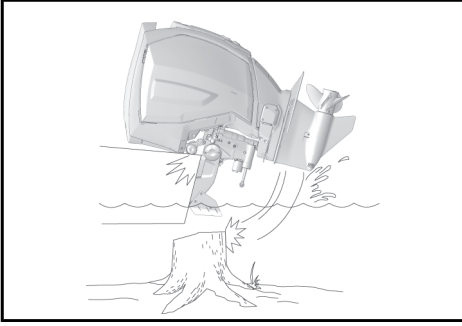

NOTICE

The outboard's shock absorption system does not work while operating in reverse. If you back into an object, either in the water or while trailering, your boat and outboard can be seriously damaged.

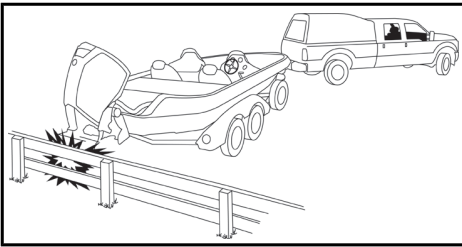

If you hit any object:

- STOP immediately and examine the outboard for loosening of attaching hardware.
- INSPECT for damage to swivel and stern brackets, and steering components.
- EXAMINE the boat for structural damage.
- TIGHTEN any loosened hardware.

If the collision occurred in the water, proceed slowly to harbor. Before boating again, have your Dealer thoroughly inspect all components.

If your engine will not trim to the fully DOWN position, it may have impacted

an underwater object. See the *SERVICE NOTE*.

⚠ WARNING

Failure to inspect for damage after an accident or striking an object could result in sudden, unexpected component failure, loss of boat control, and personal injury. Ignored damage could reduce your boat and outboard's ability to resist future impacts.

Dynamic Power Steering (DPS)

Your outboard may be equipped with Dynamic Power Steering (DPS). DPS offers three power steering assist levels.

Power Steering Assist Levels

All power steering assist levels provide the same rate of assist at engine speeds below 4500 RPM.

As engine speed increases above 4500 RPM, assist levels progressively decrease.

The factory default assist level is "Minimum". Use the *Evinrude ICON-Touch* or *ICON-CS* digital display to change the power steering assist level to "Medium" or "Maximum".

⚠ WARNING

Selection of power steering assist level is a matter of operator preference. Be aware that changing the power steering assist level can affect boat handling. After changing the level of power steering assist, operate the boat with care to become familiar with any changes in boat handling characteristics.

If your boat is not equipped with an *ICON*-digital display, your Dealer must use *Evinrude Diagnostic* software to change the power steering assist level.

Engine Monitoring

IMPORTANT: Your outboard must be equipped with an engine monitoring system such as *Evinrude ICON Touch*, *ICON*, *i-Command™*, or other NMEA 2000 compliant CAN-bus instruments.

An analog *SystemCheck®* gauge, or equivalent may be used. Analog gauges REQUIRE the installation of a digital to analog converter.

The engine monitoring system provides engine operating information and alerts you of abnormal conditions that could damage your outboard. The monitoring system consists of a dash-mounted display or gauge, a warning horn, sensors on the engine and oil tank, and related wiring.

Displays and Gauges

Gauges and displays are available in several styles, such as a *Evinrude ICON Touch*, *Nautilus 3.5 CS Digital Display* with digital LCD display or a basic *SystemCheck* gauge.

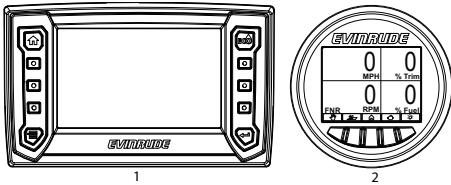

DISPLAYS AND GAUGES (TYPICAL)

1. *Evinrude ICON Touch*
2. *Nautilus 3.5 CS Digital Display*

Refer to the display or gauge user's guide for operation, warnings, and monitoring instructions.

System Self-Test

During engine start-up, pause with the key switch in the ON position. Digital displays and gauges will self test as follows:

Evinrude ICON Touch

The digital touch screen displays a "booting" screen, followed by the *Evinrude* logo and then the default home page.

SystemCheck

The *SystemCheck* monitor sounds a beep. The *SystemCheck* gauge indicator lights turn on simultaneously, then off in sequence.

Engine Monitor Warnings

Engine monitor system warnings activate the horn and the appropriate warning indicator for a minimum of 30 seconds, or until the alarm is acknowledged. If the abnormal operating condition continues, the warning indicator remains ON until the key is turned OFF or the failure is corrected.

The warning will reoccur at the next startup if the problem is not corrected.

Speed Adjusting Failsafe Electronics (S.A.F.E.)

If the *EMM* senses a problem could cause permanent engine damage, it will limit engine speed to 1200 RPM. This additional protection feature is referred to as *S.A.F.E.™* (Speed Adjusting Failsafe Electronics).

If the engine was running faster than 1200 RPM when the *S.A.F.E.* mode activated, it will shake noticeably.

Under certain operating conditions the EMM will shut OFF the engine.

⚠ WARNING

In the S.A.F.E. mode, engine speed is limited. Under certain conditions, the engine's limited speed may reduce maneuverability of your boat. If the S.A.F.E. mode is activated and you are unable to correct the problem, seek assistance and/or return to safe harbor. Serious engine damage and/or reduced maneuverability may be imminent. Under certain operating conditions the EMM will shut OFF the engine.

The following warnings may appear on the engine monitor gauge:

Critical Low Oil and SAFE Operation- Normal Trim Range

When the onboard engine oil reaches a critically low level (7.5%/ .0135 Gallons/ 500 cc remaining), the EMM will begin a count of remaining oil pulses. When the maximum amount oil pulses has been reached, the engine will enter SAFE mode. The engine will:

- Display a **Critical Low Oil** warning
- Limit engine RPM to prevent internal engine damage
- Oil pump activation will be stopped to prevent air from being introduced into the oil system

The EMM will automatically shut the engine down after 5 hours of SAFE operation. Each restart will allow the engine to run for an additional 60 seconds.

After the oil is added to the oil reservoir, the EMM will automatically start a recovery process and rapidly pulse the oil pump to re-lubricate the engine after SAFE operation.

- The recovery process will start when the engine is first restarted

- The number of recovery pulses depends on the amount of time the engine spent in SAFE mode
- The recovery process will take less than 30 seconds to complete.
- There is no need to manually re-prime the oil system after a **Critical Low Oil** occurrence.

Critical Low Oil and SAFE Operation- High Trim/ Tilt Range

When the onboard engine oil reaches a critically low level (7.5%/ .0135 Gallons/ 500 cc remaining), the EMM will begin a count of remaining oil pulses. When the maximum amount oil pulses has been reached, the engine will enter SAFE mode.

When the engine is raised in the high trim/ tilt range, oil flows to the rear of the reservoir and away from the oil pickup tube. This condition may be seen in shallow water or while loading the boat onto a trailer.

- The EMM automatically detects this condition from the trim position sensor and the oil level sensor inputs, and the oil pump is stopped to prevent air from being introduced into the oil system.
- The EMM allows for a limited amount of missed oil pulses, then enters SAFE mode. The engine will continue to run based on engine load:

The engine will continue to run based on the engine load:

- 2 hours at idle
- 50 seconds at WOT (Wide Open Throttle)
- The EMM will automatically shut down the engine after 3 hours of SAFE mode operation.

After the engine is trimmed down far enough to cover the oil pickup tube, the EMM will automatically start a recovery process to re-lubricate the engine.

TEMP or HOT

The TEMP warning indicates the engine is overheating. Depending on the severity of the overheating, the *EMM* may initiate one or more of the following failsafe actions:

- activate the TEMP warning or HOT indicator
- activate S.A.F.E. mode
- activate shut down

If the TEMP warning activates, see *TROUBLESHOOTING*.

CHECK ENGINE

The CHECK ENGINE warning indicates an abnormal engine condition. Depending on the severity of the condition, the *EMM* may initiate any of the following failsafe actions:

- activate the display warning or CHECK ENGINE indicator
- activate S.A.F.E. mode
- activate shut down

If the CHECK ENGINE warning activates, see *TROUBLESHOOTING*.

WARNING

If the outboard shuts OFF and the "CHECK ENGINE" indicator is flashing, the outboard cannot be restarted. A hazardous fuel condition may exist.

Seek assistance to return to port. Seek service from an authorized *Evinrude* dealer, repair shop, or person of your own choosing for maintenance, repair, or replacement.

Special Operating Conditions

Cold and Freezing Weather

NOTICE

When operating in conditions under 32°F (0°C), XD100™ oil must be used.

During operation in freezing weather, keep the gearcase submerged at all times.

Upon removing your outboard from the water, leave it in a vertical position until its cooling system is drained. Store the outboard vertically.

NOTICE

Water remaining in the gearcase, cooling system or other components can freeze, causing serious engine damage.

Multiple Outboard Operation

When in reverse above slow speed, be sure all outboards are running, even if one is in NEUTRAL.

If it is necessary to return to harbor with one outboard not running, tilt the inoperative outboard high enough to keep its propeller out of the water.

High Altitude

Your outboard's *EMM* will automatically compensate for changes in altitude. However, if you boat above 3000 ft. (900 m), you will experience some loss of power due to reduced air density.

If your engine drops below the recommended RPM operating range at full throttle, have your Dealer select a lower pitch propeller.

If you return to sea level, have your Dealer install the original propeller and verify correct RPM operating range.

Salt Water

Anode protection for the outboard has been provided for use in salt or brackish water.

Upon removal from salt water, leave outboard in a vertical position until its cooling system has drained. During long periods of mooring, tilt the

gearcase out of the water, except in freezing temperatures. Flush the outboard, if desired. Refer to *FLUSHING*.

Shallow Water

Gearcase damage can occur if the gearcase is allowed to drag on the waterway bottom. Use caution when operating in shallow water.

IMPORTANT: Impact damage is NOT covered by the outboard warranty.

Under Tow

Should you require a tow from another boat:

- Shift your engine to NEUTRAL
- Tilt the gearcase out of the water
- Off-load all persons into another boat
- Keep speed slower than planing speed

Weedy Water

Weeds block water intakes and may cause your outboard to overheat. Weeds on the propeller create vibration and reduce boat speed.

When operating in weedy water, run at slow speeds and in REVERSE frequently to clear weeds from the propeller and water intakes. Check the water pressure often.

If the REVERSE operation does not clear away weeds, SHUT OFF the engine. Remove weeds from propeller area and water intakes before operating at higher speed.

Transporting the Outboard

Trailer

⚠ WARNING

Keep everyone clear of stern area when raising or lowering the outboard. Personal injury or death can result from contact with moving parts of the outboard.

NOTICE

When trailering your outboard, DO NOT cover the engine with canvas. This will dull the finish of the outboard's engine covers.

Trailer

The outboard is designed to be trailered in a tilted position using the trailering lock lever, or in a vertical position.

To engage the lock lever, tilt the outboard to the full up position.

Lower the lock lever

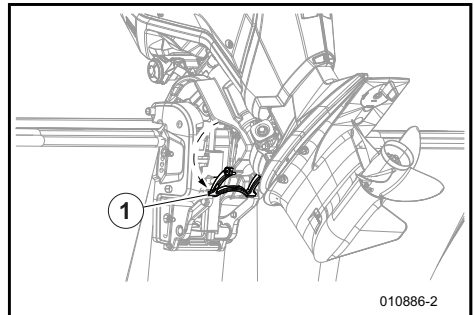

1. Trailering Lock Lever

Tilt the outboard down until the trailering lock lever engages the stern bracket.

To release the trailering lock lever, tilt the outboard up, and retract the trailering lock lever to the storage position.

contaminants from entering the hydraulic system.

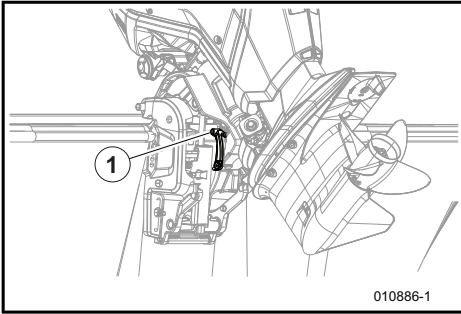

010886-1

1. Trailing Lock Lever

Transporting / Storage

If the outboard is removed from the boat for transportation or storage, you **MUST**:

- Seal the oil and fuel lines on the boat and on the outboard to prevent leaks and prevent contaminants from entering the oil or fuel system.
- Install shipping brackets to prevent the outboard from turning.
- Cap steering fittings on the outboard and hydraulic hoses to prevent leaks and prevent

⚠ WARNING

A small amount of fuel may be released when the fuel line is disconnected. Gasoline is extremely flammable and highly explosive under certain conditions. Do not allow disconnected fuel hoses to leak fuel. Use caution when working on the fuel system. Wear safety glasses and work in a well ventilated area. Extinguish all smoking materials and make certain no open flames or ignition sources exist. Always wipe off any fuel spillage.

ENVIRONMENTAL NOTE

Dispose of oil or fuel contaminated towels in an environmentally responsible manner, or according to local regulations.

The engine is shipped from the factory without color engine cover panels. A shipping cover is used to protect the engine during shipment.

NOTICE

Do not install the shipping cover after the engine cover panels are installed, the decals or covers could be scratched.

DPS Steering Lock

⚠ WARNING

Always remove the steering lock pin before turning the engine key switch on. The engine will not turn with the pin in place.

1. Remove the steering lock pin from the swivel bracket.

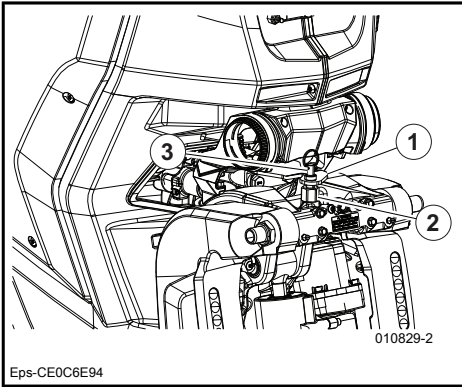

1. *Steering Arm*
2. *Stern Bracket Boss*
3. *Lock Pin*

2. Insert the steering lock pin into the swivel bracket boss for storage.

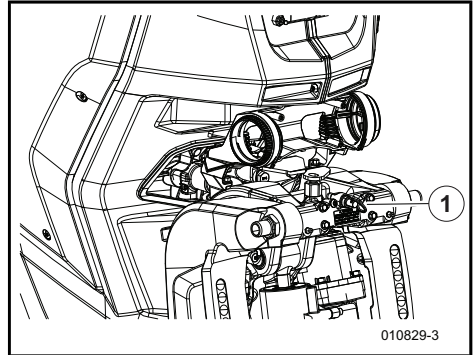

1. *Lock Pin*

Pre-Ride Inspection

Pre-Ride Inspection Checklist

WARNING

Always perform a pre-ride inspection before operating the boat. Check the proper operation of critical controls, safety features and mechanical components. Correct any problems BEFORE leaving the dock. Make sure all safety equipment required by local law is onboard.

WARNING

The engine(s) should be OFF and the tether cord must always be removed from the engine cut-off switch before verifying any of the following. Only start the engine(s) after all items have been checked and operate properly.

ITEM	OPERATION	X
Hull	Inspect	
Propeller	Inspect condition of propeller. Repair or replace if necessary	
Cooling System	Inspect water intake screens	
Safety Equipment	Ensure safety equipment is onboard	
Oil Level	Check. Refill as needed	
Bilge	Drain. Ensure drain plug(s) are securely installed.	
Battery	Check battery connections are clean, tight, and insulated. Ensure battery/battery box are secure.	
Fuel level	Check. Refill as needed.	
Navigation lights	Check operation.	
Steering system	Check operation.	
Boat systems (horn, pumps, radio)	Check operation.	
Engine cut-off switch/ tether cord	Inspect condition of tether cord. Attach to key switch or engine cut-off switch (depending on application). Test operation. Reattach tether cord to switch.	
Operator's Guide	Confirm this Operator's Guide is onboard and readily accessible.	

ITEM	OPERATION	X
Key / Engine Start switches	Test operation.	
Displays & Gauges	Self-test and warning horn, check operation	
Shift and Throttle	Check operation.	
Trim System	Check operation.	
Cooling system	Confirm operation (water pump indicator).	

Aquatic Invasive Species (AIS)

Aquatic Invasive Species (AIS) are non-native plant or animal species that threaten the diversity or abundance of the native species. They also threaten the natural ecology of the body of water they infest. AIS almost always has a negative impact on the waterway, its native species, and recreational or commercial activities.

Common examples of AIS are:

- Eurasian Watermilfoil
- Hydrilla
- Sea Lampreys
- Zebra Mussels
- Asian Carp
- Gobies

Many other examples of AIS exist throughout the worlds waterways.

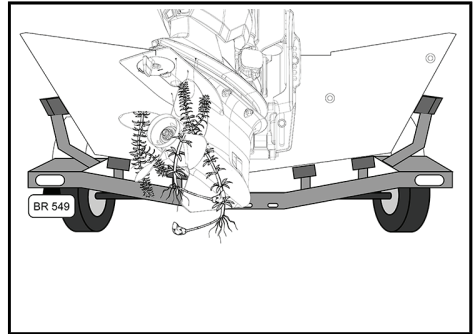

AIS On Outboards

A typical factor in AIS infestations is that the non-native species are introduced by human activity. Some AIS are introduced by commercial operations; however AIS can be introduced through recreational boating activities. The transportation of recreational boats and water sports equipment between waterways can be a major factor in the spread of AIS

As responsible boat owners, we MUST do our part to prevent the spread of these aquatic hitchhikers. Check your boat each time you leave the water! In many cases it is required by law, be sure to check the local regulations for the waterways where you boat.

Clean, Drain and Dry- Everything, Every Time!

Before you leave a waterway, follow the procedure below to help prevent the spread of AIS.

Clean

Inspect and remove any visible mud, aquatic plants, fish or animals from the boat, trailer and any water sports equipment before transporting your equipment.

AIS Inspection Checklist

Use the following checklist as a guide when inspecting for AIS.

Drain

Remove all water from the boat, including the ballast, bilge, livewell, engine, and gearcase. Dispose of unwanted live bait in the trash.

Dry

Allow the boat to dry completely before visiting any other bodies of water.

Inspection Items			✓
Boat	1	Inspect hull.	
	2	Inspect floor.	
	3	Inspect live well.	
	4	Inspect transom well.	
		Inspect water inlet & outlet fittings.	
		Inspect anchors and lines.	
		Inspect boarding ladder.	
		Inspect transducers or other attachments to the hull.	
Accessories		Inspect fishing tackle and fishing lines.	
		Inspect bait buckets.	
		Inspect landing nets.	
		Inspect water sports equipment (skis, wakeboards etc.).	
		Inspect tow ropes.	
Outboard(s)	5	Inspect water intake screens.	
	6	Inspect gearcase.	
	7	Inspect propeller.	
Trailer	8	Inspect bunks and/or rollers.	
	9	Inspect fenders & frame.	
	10	Inspect tires & wheels (including spare tire)	
		Inspect license plate & brackets.	
		Inspect lights and wiring.	

TableJpg-CF0AD52C

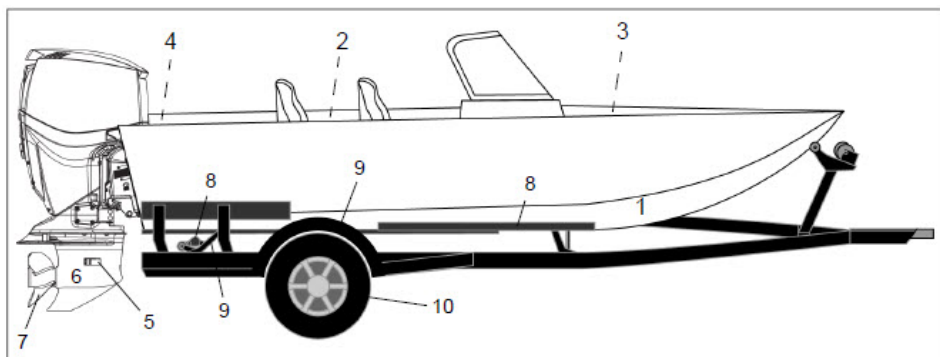

EMISSIONS INFORMATION

ENGINE EMISSIONS INFORMATION

A repair shop or person of the owner's choosing may maintain, replace, or repair emission control devices and systems. These instructions do not require components or service by BRP or authorized *Evinrude* dealers. Although an authorized *Evinrude* dealer has the in-depth technical knowledge and tools to service *Evinrude* outboard engines, the emission-related warranty is not conditioned on the use of an authorized *Evinrude* dealer or any other establishment with which BRP has a commercial relationship.

For emission-related warranty claims, BRP is limiting the diagnosis and repair of emission-related parts to authorized *Evinrude* dealers. For more information, please refer to the US EPA EMISSION-RELATED WARRANTY contained herein. Proper maintenance is the owner's responsibility. A warranty claim may be denied if, among other things, the owner or operator caused the problem through improper maintenance or use.

You must follow the instructions for fuel requirements in the *FUEL REQUIREMENTS* section of this manual. Even if gasoline containing greater than ten volume percent ethanol is readily available, the US EPA has issued a prohibition against the use of gasoline containing greater than 10 vol% ethanol that applies to this engine. The use of gasoline containing greater than 10 vol% ethanol with this engine may harm the emission control system.

Manufacturer's Responsibility

Beginning with 1999 model year outboards, manufacturers of marine engines must determine the exhaust emission levels for each engine horsepower family and certify these outboards with the United States of America Environmental Protection Agency (EPA). An emissions control information label, showing emission levels and engine specifications, must be placed on each outboard at the time of manufacture.

Dealer's Responsibility

When performing service on all 1999 and more recent *Evinrude* outboards that carry an emissions control information label, adjustments must be kept within published factory specifications.

Replacement or repair of any emission related component must be executed in a manner that maintains emission levels within the prescribed certification standards.

Dealers are not to modify the outboard in any manner that would alter the horsepower or allow emission levels to exceed their predetermined factory specifications.

Exceptions include manufacturer's prescribed changes, such as altitude adjustments, for example.

Owner Responsibility

The owner/operator is required to have engine maintenance performed to maintain emission levels within prescribed certification standards.

The owner/operator is not to, and should not allow anyone to, modify the engine in any manner that would alter the horsepower or allow emissions levels to exceed their predetermined factory specifications.

Tampering with the fuel system to change horsepower or modify emission levels beyond factory settings or specifications will void the product warranty.

EPA EMISSION REGULATIONS

All new 1999 and more recent *Evinrude* outboards are certified to the EPA as conforming to the requirements of the regulations for the control of air pollution from new watercraft marine spark ignition outboards. This certification is contingent on certain adjustments being set to factory standards. For this reason, the factory procedure for servicing the product must be strictly followed and, whenever practical, returned to the original intent of the design. The responsibilities listed above are general and in no way a complete listing of the rules and regulations pertaining to the EPA requirements on exhaust emissions for marine products. For more detailed information on this subject, you may contact the following locations:

U.S. Environmental Protection Agency
Office of Transportation and Air Quality
Certification Division
Gasoline Engine Compliance Center
2000 Traverwood Drive
Ann Arbor, MI 48015

EPA Internet Web Site:

<http://www.epa.gov/otaq>

INSPECTION SCHEDULE

Inspection Table

Routine inspection and maintenance is necessary to ensure outboard life. The following chart provides guidelines for inspection and maintenance. The 500 hour/5 year service should be performed by an authorized Dealer, repair shop, or person of your own choosing.

IMPORTANT: Adjust the maintenance schedule for operating and environmental conditions. Outboards used in rental, commercial, or other high hour applications require more frequent inspections and maintenance.

Description	Dealer Maintenance Every 500 Hours or 5 Years			
	Customer Inspection Every 100 Hours or Annually			
	Engine Care Products			
	Action			
Anodes (corrosion protection)	Check condition ⁽¹⁾ , ⁽²⁾		X	X
Covers	Wash		X	
Fluid Levels (steering and trim)	Inspect level			X
Fuel filters	Replace			X
Gearcase lubricant	Inspect level, See <i>GEARCASE LUBRICANT LEVEL</i> .		X	
Gearcase lubricant	Replace	A		X
Grease fittings	Lubricate	B		X
Oil Filter (optional remote oil tank only)	Replace			X
Propeller shaft splines	Inspect and lubricate	B		X
Service codes	Access EMM, check for and resolve any codes			X
Spark plugs	Replace ⁽³⁾			X
Thermostat	Inspect ⁽³⁾			X
Water pump	Replace			X

(1) Whichever comes first. Certain conditions may require more frequent inspection and maintenance.

(2) Annually in salt water applications.

(3) Emission-related component.

Engine Care Products

The engine care products listed in the table below are tested, proven, and are recommended for use with *Evinrude E-TEC* outboards.

	Product	Use
A.	<i>HPF PRO</i> Gearcase Lubricant	Gearcase
B.	<i>Triple Guard</i> Grease	Grease fittings, propeller shaft
—	<i>Power Trim/Tilt</i> Fluid, P/N 767969	Power Trim and Tilt System
—	<i>SeaStar</i> Steering Fluid, P/N 770891	Hydraulic Steering System
—	<i>Evinrude 2+4 Fuel Conditioner</i>	Protect fuel system and condition fuel
—	Anti-Corrosion Spray	Protect metal parts from corrosion

MAINTENANCE

MAINTENANCE

The following maintenance procedures will help you maintain your *Evinrude* outboard.

Anodes

Your outboard is equipped with one or more sacrificial anodes that protect it from galvanic corrosion. Disintegration of the anode is normal and indicates it is working. Check each anode periodically. Replace anodes smaller than 2/3 their original size. See your Dealer for replacements.

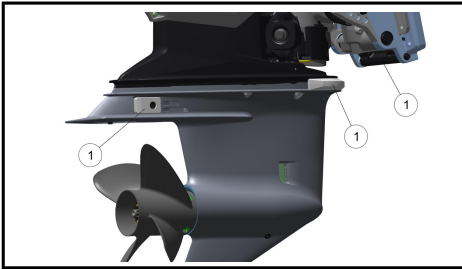

1. Anode

Galvanic corrosion destroys underwater metal parts and can occur in fresh or salt water; however, salt, brackish, and polluted waters will accelerate corrosion.

Metal-based anti-fouling paint on the outboard and the use of improperly installed shore power in the area of your moored boat will also accelerate corrosion.

NOTICE

NEVER paint the anode, its fasteners, or its mounting surface. Painting will reduce its corrosion protection.

Fuses

A blown fuse could prevent the engine from starting.

The fuse box is located under the engine covers, and requires the removal of the starboard cover to gain access. Please see your local servicing

Evinrude dealer or consult the *Evinrude* service manual.

Fuse Replacement

NOTICE

Use only fuses of the same rating

Your outboard uses the following Mini-fuses. See your dealer for replacement fuses.

Fuses	
Fuse Rating	Replacement Fuse P/N
3	3011805
5	514764
10	514766
30	3011729

Remove the starboard engine cover. Remove the cover from fuse box. Replace the failed fuse.

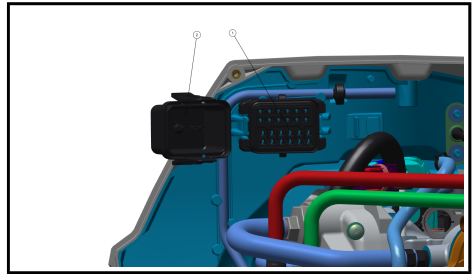

1. Fuse Box
2. Fuse Box Cover

Gearcase Lubricant Level

1. Remove the starboard engine cover from the engine.
2. Inspect the level of oil in the oil reservoir.

must be inspected for signs of water intrusion. See the *SERVICE NOTE*.

Storage

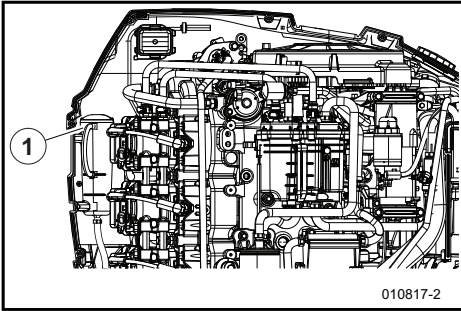

1. Gearcase Lubricant Reservoir
3. The lubricant level should be between the reservoir as shown below.

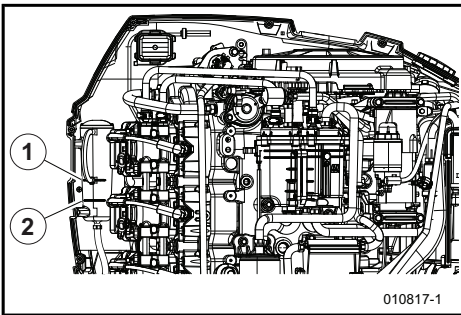

1. Maximum Gearcase Lubricant Level
2. Minimum Gearcase Lubricant Level

Outboard External Finish

Periodically, wash the entire boat and outboard with soapy water and apply a coat of automotive wax. Leave the engine covers in place when washing the outboard.

NOTICE

If needed, use *Evinrude Marine Cleaner* to clean plastic covers or panels. Do NOT use solvents such as acetone.

Submerged Outboard

If your outboard has been under water, have it serviced immediately upon recovery.

After submersion, all boat and engine electrical, fuel, and oiling systems

⚠ WARNING

DO NOT run the engine indoors or without adequate ventilation or permit exhaust fumes to accumulate in confined areas. Engine exhaust contains carbon monoxide which, if inhaled, can cause serious brain damage or death.

Protect against natural environmental conditions that can be damaging to an outboard. Your warranty does not cover engine failure caused by these conditions.

NOTICE

Temperature and humidity changes during storage period can cause corrosion of internal engine components.

Stabilize the fuel supply. Fuel remaining in your fuel tank can oxidize, resulting in loss of octane and fuel system deposits.

Use *Evinrude 2+4 Fuel Conditioner* to prevent gum and varnish deposits from forming in fuel system components.

⚠ WARNING

Prevent injury from moving engine components. Before starting the outboard:

- Shift it to NEUTRAL.
- Keep hands, clothes, and hair clear of powerhead.

If on a trailer, remove the propeller.

If the outboard is removed from the boat for transportation or storage, you MUST:

- Seal the oil and fuel lines on the boat and on the outboard to prevent leaks and prevent contaminants from entering the oil or fuel system.
- Install shipping brackets to prevent the outboard from turning.
- Cap steering fighting on the outboard and hydraulic hoses to prevent leaks and prevent contaminants from entering the hydraulic system.

Short-Term Storage

If you must tilt the outboard to remove it from the water, lower it and allow the cooling system to drain completely as soon as you clear the launch area. Between uses, store your outboard in a vertical position.

Long Term Storage (Winterization)

⚠ WARNING
If winterizing on a trailer, the propeller must be removed before performing procedure. Failure to remove propeller can cause personal injury or death.

Winterization prepares your outboard for long-term off-season storage. During winterization, the engine is "fogged" with extra oil to coat internal engine components.

Winterization requires a specific process of steps.

NOTE: The *Evinrude ICON* touch digital display provides a one-touch winterization. See the **ICON Touch User's Guide**.

Closely follow the applicable winterization procedure for your outboard:

- Remote control
- Remote control with foot throttle

You can confirm your outboard enters winterization mode when the engine runs at fast idle and:

- The *ICON* gauge will display a winterization message (if equipped).
- The *SystemCheck* gauge lights flash (if equipped).

Preparation

Your outboard can be winterized in the water. If winterizing in water, make sure the water intake screens are completely submerged.

1. Stabilize the engine's fuel supply. Add 2 +4 Fuel Conditioner following instructions on container. Fill fuel tank.
2. If winterizing on a trailer, remove the propeller. Attach a garden hose to flushing port and turn on the water. Refer to .
3. Turn the key switch to the OFF position.
4. Move the lever (s) to the FORWARD wide open throttle position.

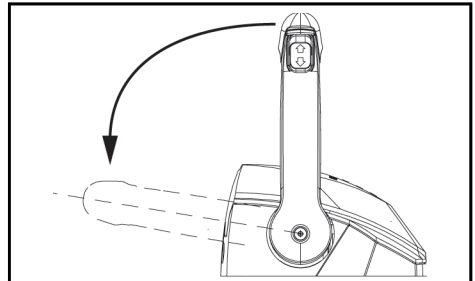

BINNACLE MOUNT CONTROL (SHOWN)

5. Turn the key switch to ON and wait a minimum of three seconds.
6. Attempt to start the outboard three times within three seconds (the starter will not engage or crank the outboard).
7. Move the lever to NEUTRAL and start the outboard(s).
8. Run the outboards at idle for a minimum of three seconds.
9. With the outboard (s) running, attempt to start the outboard three times within three seconds (the starter will not engage or crank the outboard).
10. The remote control will send the winterization message to each

outboard. Only running outboard (s) will be winterized.

11. The outboard(s) will automatically shut off when the process is complete.

During the winterization process, the remote control will ignore all throttle, gear, and switch operations. The control WILL acknowledge Key OFF or Emergency Stop commands. Trim the outboard to the fully down position to store. If the outboard must be stored in a tilted position, make SURE the cooling system is drained completely BEFORE tilting.

Preparation

Surface Side Mount Control

Your outboard can be winterized in the water. If winterizing in water, make sure the water intake screens are completely submerged.

1. Stabilize the engine's fuel supply. Add 2+4 Fuel Conditioner following instructions on container. Fill fuel tank.
2. If winterizing on a trailer, remove the propeller. Attach a garden hose to flushing port and turn on the water. Refer to .
3. Turn the key switch to the OFF position.
4. Move the lever(s) to the FORWARD wide open throttle position.

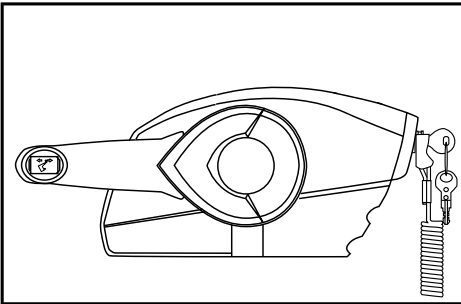

5. Turn the key switch to ON and wait a minimum of three seconds.

6. Push the engine trim button in the following order within 3 seconds: **DOWN, UP, DOWN**.
7. Move the lever to NEUTRAL and start the outboard(s).
8. Run the outboards at idle for a minimum of three seconds.
9. With the outboard (s) running, repeat the **DOWN, UP, DOWN** trim procedure.
10. The remote control will send the winterization message to each outboard, and engine idle will rise. Only running outboard (s) will be winterized.
11. The outboard (s) will automatically shut off when the process is complete.

During the winterization process, the remote control will ignore all throttle, gear, and switch operations. The control WILL acknowledge Key OFF or Emergency Stop commands. Trim the outboard to the fully down position to store. If the outboard must be stored in a tilted position, make SURE the cooling system is drained completely BEFORE tilting.

Pre-Season Check

Remove your outboard from storage and prepare it for a season of reliable service by performing a general check and a few preventive maintenance procedures.

Check for loosened or removed hardware. Replace damaged or missing parts with *Evinrude Genuine Parts* or equivalent. Check the gearcase for leakage. If leakage is evident, the gearcase seals should be replaced.

IMPORTANT: Gearcase lubricant is thick and clear. Do not confuse this with engine oil, which may normally appear on the skeg after performing the long-term storage procedure.

Check the condition of the anti-corrosion anodes. See **Anodes**.

Charge the battery. See **Battery**

⚠ WARNING

Do not use a booster battery and jumper cables to start the outboard. Gasoline fumes can cause explosion and fire, resulting in property damage, personal injury or death.

Review your outboard's warning system self-test routine. During start-up, make sure the warning system self-tests properly.

NOTICE

Do not run your outboard—even for a brief start-up—without supplying water to it.

S.A.F.E. Reset

In the event of an engine overheat, it may be possible to reset the *S.A.F.E.* system and restore normal operation:

- The engine must be shut off and the cooling temperature restored.

IF the *S.A.F.E.* mode activates and water pressure becomes intermittent or stops, reduce speed to idle and:

1. Shift to NEUTRAL
2. SHUT OFF the engine
3. Tilt the outboard up
4. Clean the water intake screens of any blockage
5. Clean the water pump indicator if any blockage
6. Lower the outboard
7. Restart the engine and run at idle

IF cleaning the screens and indicator does not restore the water pump indicator's steady discharge, the engine will operate only in *S.A.F.E.* mode. Return to harbor immediately. See the *SERVICE NOTE*.

Following **Engine Starting**, start the outboard. If the outboard was winterized, it will emit a puff of smoke on the first start of the season.

Let engine idle while you:

Observe running quality. If poor, refer to **Troubleshooting**.

Confirm water pump operation. Water must flow from the water pump indicator in a steady stream. If it does not, shut off the outboard and investigate.

Stop the outboard and check the fuel system for leaks.

⚠ WARNING

Failure to check for fuel leakage could allow a leak to go undetected, resulting in fire or explosion.

IF cleaning the screens and indicator does re-store the water pump indicator's steady discharge, you might have to run for two minutes in NEUTRAL to allow the engine to cool and the warning indicator to turn OFF.

IMPORTANT: If cooling is not restored, the *EMM* will identify a progressive overheating condition and shut off the engine. The "TEMP" warning will flash. The engine will not restart until the engine is allowed to cool. After any overheat causing engine shutdown, The following items should be inspected:

- Inspection of the water pump for excessive wear or damage.
- Inspection of the thermostats.
- See the *SERVICE NOTE*.

NOTICE

Although the *S.A.F.E.* mode can help prevent engine damage, it does not guarantee you can run your engine indefinitely without engine damage.

Emergency Start Procedure

IMPORTANT: *Evinrude E-TEC* models use a dedicated remote control network for all remote control-related functions. In the event network communication between the remote control and the engine *EMM* is disabled, back-up remote control function is provided using the *NMEA 2000* network.

Start the engine using the following procedure:

1. Turn the key switch to the ON position.

NOTE:

The NEUTRAL LED indicator on the remote control will flash rapidly, and digital displays may show a network communication service code or warning.

2. Use the trim switch on the port side on the engine to momentarily activate the trim system.

In multiple engine applications, repeat this procedure for each engine.

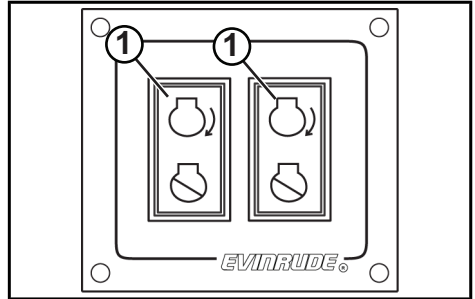

TYPICAL (DUAL ENGINE SHOWN)

1. Start buttons

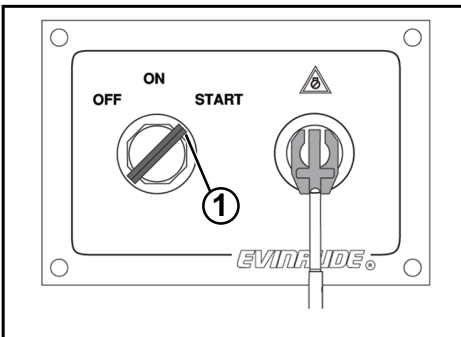

1. Key switch START position

Specifications Table

Specifications Inline 3-Cylinder 1.865L 115 H.O., 140 HP, 150 HP		
Displacement	113.865 cu.in. (1865cc)	
Engine Type	Inline 3-Cylinder, Two-Cycle, E-TEC	
Full Throttle Operating Range ⁽¹⁾	115 HP H.O. – 5000 to 6000 RPM 140 HP – 5000 to 6000 RPM 150 HP –5000 to 6000 RPM	
Power ⁽¹⁾	115 HP H.O. – (84.60 kw) @ 5500 RPM 140 HP – (100.80 kw) @ 5500 RPM 150 HP – (110.32 kw) @ 5500 RPM	
Idle RPM in Neutral ⁽²⁾	500± 50	
Idle RPM in Gear ⁽²⁾	600± 50	
Ignition Timing ⁽²⁾	Controlled by the outboard's <i>EMM</i>	
Emission Control System: per SAE J1930 ⁽²⁾	EMM, <i>E-TEC</i> (Engine Control Module, <i>E-TEC</i>)	
Fuel Requirements ⁽²⁾	AKI (R+M)/2 — 87 Octane	
Oil	Lubricant	Evinrude XD [†] oils or a synthetic TC-W3 NMMA-certified oil – 1.88 Gallons (7.12 liters) [†] <i>Evinrude XD oils exceed the specifications of NMMA TC-W3 certification</i>
	Capacity	
Warning Signals	Controlled by the outboard's <i>EMM</i>	
Battery, Minimum ⁽³⁾	675 CCA (845 MCA) 12 volt or 750 CCA (940 MCA) 12 volt below 32°F (0°C)	
Spark Plug ⁽²⁾	Type	CHAMPION QC8WEPIA
	Gap	0.028 in. (0.71 mm)
Fuses	Mini-fuse: 3A- 3011805 5A- 504764 10A- 514766 30A- 3011729	
Fuel Filters	Inline	P/N 360941
	Water Separating	P/N 5009902

Specifications Inline 3–Cylinder 1.865L 115 H.O., 140 HP, 150 HP		
Battery Charging	30 Amp, Fully Regulated, Single Output	
Hydraulic Steering Fluid	Use ONLY: SeaStar Hydraulic fluid, P/N 770891 Hydraulic fluid meeting MIL SPEC: Mil-H-5606	
Power Trim/Tilt	Fluid	<i>Power Trim/Tilt Fluid</i> , P/N 767969
	Capacity	21 fl. oz. (710ml)
Gearcase	Lubricant ⁽⁴⁾ and Capacity	<i>Evinrude HPF Pro</i> Gearcase Lubricant Gearcase (Standard Rotation and Counter Rotation, 13:27/0.48/ 2.08:1 ratio) Gearcase only – 26.9 fl. oz. (795 ml) Gearcase, vent hose and oil bottle 32.8 fl. oz. (969 ml)
Propeller	RX3 (3 Blade) or RX4 (4 Blade) depending on application. See your <i>Evinrude</i> dealer for more information.	
Weight (Non—DPS Models)	L Models	378 lbs (171 kg)
	X Models	386 lbs (175 kg)
Weight (DPS Models)	L Models	390 lbs (177 kg)
	X Models	398 lbs (181 kg)
Sound at Driver's Ear (LpA) ICOMIA 39.94	88.0 dBA	
Transom Height	L Models	19 1/2 to 20 in. (495 to 508 mm)
	X Models	24 1/2 to 25 in. (622 to 635 mm)

Specifications Inline 3-Cylinder 1.865L 115 H.O., 140 HP, 150 HP	
NMEA 2000 Support	Load Equivalency Number (LEN): 1 Receive PGNs: 127488, 129026 Transmit PGNs: 127488, 127489, 127493, 127505, 127508, 130310 Also supports the mandatory PGNs included in <i>NMEA 2000</i> Library Version 3.101

- (1) Rated following the standards of ICOMIA 28.83, ISO 3046 and NMMA
- (2) Emission Control Information.
- (3) Under extraordinary electrical load or environmental conditions, use a 107 amp-hour minimum battery (generally available in group 29 size).
- (4) Use *Evinrude HPF Pro* Gearcase Lubricant for high performance outboards and commercial applications. *Evinrude HPF Pro* Gearcase Lubricant delivers exceptional durability and reliability and promotes long gearcase life in marine use.

Product Warranty Information

BRP US Inc. Limited Warranty For Evinrude Outboard Engines

1. Scope Of The Lifetime Warranty

BRP US Inc.* ("BRP") warrants its *Evinrude* outboard engines sold by authorized *Evinrude* dealers ("Product") from defects in material or workmanship for the period and under the conditions described below.

2. Exclusions — The following are not warranted under any circumstances:

- Replacement of parts due to normal wear and tear;
- Routine maintenance parts and services including but not limited to: maintenance requirements, engine and lower unit oil changes, lubrication, valve and linkage adjustments and replacement of fuses, zinc anodes, thermostats, timing belts, starter motor bushings, trim motor brushes, filters, propellers, propeller bushings and spark plugs;
- Damage caused by improper or lack of installation, maintenance, winterization and/or storage, failure to follow the procedures and recommendations in the Operator's Guide;
- Damage resulting from removal of parts, improper repairs, service, maintenance, or modification, or use of parts or accessories not manufactured or approved by BRP, which in its reasonable judgment, are either incompatible with Product or adversely affect its operation, performance, or durability, or resulting from repairs done by a person that is not an authorized Dealer (as described below);
- Damage caused by abuse, misuse, abnormal use, neglect, racing, improper operation or operation of the Product in a manner inconsistent with the recommended operation described in the Operator's Guide;
- Damage resulting from external damage, accident, submersion, water ingestion, fire, theft, vandalism or any act of God;
- Operation without proper fuel, oil or lubrication, or with fuels, oils or lubricants which are not suitable for use with the Product (see the Operator's Guide);
- Damage resulting from rust or corrosion (also see the **Limited Corrosion Warranty** on page 64);
- Damage caused from cooling system blockage by foreign material;
- Damage resulting from sand or debris in the water pump;
- Cosmetic or paint changes due to exposure to the elements.

This warranty will be voided in its entirety and rendered null and void where:

- "Product has been altered or modified in such a way so as to adversely affect its operation, performance or durability, or change its intended use, horsepower or emission levels; or
- "Product is or has been used for racing at any point, even by a prior owner.

3. Limitations of Liability

ALL INCIDENTAL, CONSEQUENTIAL, DIRECT, INDIRECT OR OTHER DAMAGES OF ANY KIND ARE EXCLUDED FROM COVERAGE UNDER THIS WARRANTY INCLUDING, BUT NOT LIMITED TO: expense for gasoline, expense for transporting Product to and from Dealer, removal of Product from a boat and reinstallation, mechanic's travel time, in-and-out of water

charges, slip or dock fees, trailering or towing, storage, telephone, cell phone, fax or telegram charges, rental of a like or replacement Product or boat during warranty services or down time, taxi, travel, lodging, loss of or damage to personal property, inconvenience, cost of insurance coverage, loan payments, loss of time, loss of income, revenue or profits, or loss of enjoyment or use of Product.

SOME STATES, PROVINCES, OR JURISDICTIONS DO NOT ALLOW FOR THE DISCLAIMERS, LIMITATIONS OF INCIDENTAL OR CONSEQUENTIAL DAMAGES, OR OTHER EXCLUSIONS IDENTIFIED ABOVE. AS A RESULT, THEY MAY NOT APPLY TO YOU. THIS WARRANTY GIVES YOU SPECIFIC RIGHTS, AND YOU MAY ALSO HAVE OTHER LEGAL RIGHTS WHICH MAY VARY FROM STATE TO STATE, OR PROVINCE TO PROVINCE.

No distributor, Dealer or any other person is authorized to make any affirmation, representation or warranty regarding Product other than those contained in this limited warranty and, if made, shall not be enforceable against BRP. BRP reserves the right to modify this warranty at any time, being understood that such modification will not alter the warranty conditions applicable to the Products sold while this warranty is in effect.

4. Warranty Coverage Period

This limited warranty will be in effect from the date of delivery to the first retail consumer or the date the Product is first put to use, whichever occurs first, for a period of:

1. THIRTY-SIX (36) CONSECUTIVE MONTHS for private, recreational use; or
2. TWELVE (12) CONSECUTIVE MONTHS for commercial use. The Product is used commercially when it is used in connection with any work or employment that generates income, during any part of the warranty period. The Product is also used commercially when, at any point during the warranty period, it is installed on a boat that has commercial tags or is licensed for commercial use. In cases where the delivery date is not established to BRP's satisfaction, the date of sale will be used to determine the warranty start date.
3. For emission-related components; please also refer to the US EPA EMISSION-RELATED WARRANTY contained herein.
4. For *Evinrude* outboard engines produced by BRP for sale in the State of California that are originally sold to a resident or subsequently warranty registered to a resident in the State of California, please also refer to the applicable California Emissions Control Warranty Statement contained herein.

See your Dealer or your BRP Extended Service Terms (*B. E. S. T.*) contract for terms and conditions.

The repair or replacement of parts or the performance of service to Product under this warranty does not extend the life of this limited warranty beyond its original expiration date. For All *Evinrude / Johnson* Genuine Parts and accessories installed by an authorized dealer at the time of sale, reference the BRP parts and accessories limited Warranty Statement.

FOR PRODUCTS SOLD IN AUSTRALIA ONLY

Nothing in these Warranty terms and conditions should be taken to exclude, restrict or modify the application of any condition, warranty, guarantee, right or remedy conferred or implied under the Competition and Consumer Act 2010 (Cth), including the Australian Consumer Law or any other law, where to do so would

contravene that law, or cause any part of these terms and conditions to be void. The benefits given to you under this limited warranty are in addition to other rights and remedies that you have under Australian law.

Our goods come with guarantees that cannot be excluded under the Australian Consumer Law. You are entitled to a replacement or refund for a major failure and for compensation for any other reasonably foreseeable loss or damage. You are also entitled to have the goods repaired or replaced if the goods fail to be of acceptable quality and the failure does not amount to a major failure.

5. Conditions to Have Warranty Coverage

This warranty coverage is available only on *Evinrude* outboard engines purchased as new and unused from a dealer authorized to distribute *Evinrude* products in the country in which the sale occurred ("Dealer"), and then only after the BRP specified pre-delivery inspection process has been completed and documented by the purchaser and Dealer. Warranty coverage only becomes available upon proper registration of Product by Dealer or owner.

Only the original purchaser and any subsequent owners who reside in the United States and Canada and have purchased Product from a U.S. or Canadian Dealer are eligible for warranty registration and warranty coverage hereunder. Such limitations are necessary in order to allow BRP to protect the safety of its products, its consumers, and the general public.

As outlined in the Operator's Guide, timely routine required maintenance must be performed to maintain warranty cover-age. BRP may require proof of proper maintenance prior to authorizing warranty coverage.

6. What to do to Obtain Warranty Coverage

The registered owner must notify an authorized Dealer within two (2) days of the appearance of a defect. BRP is not responsible for damages caused by the use of a Product after the appearance of a defect. Owner must bring Product, including any defective part therein, to Dealer promptly after the appearance of the defect, and in any event, within the warranty period, and must provide Dealer with reasonable opportunity to repair the defect. The expenses of transporting Product to and from Dealer for warranty service are to be borne by the owner.

If the Product has not previously been registered, the owner may also be required to present proof of purchase to Dealer for warranty repairs. Owner is required to sign the repair/work order prior to the start of the repair in order to validate the warranty repair.

All parts replaced under this warranty become the property of BRP.

7. What BRP Will Do

BRP's obligations under this warranty are limited to, at its sole discretion, repairing or replacing parts of Product found to be defective in material or workmanship, in the reasonable judgment of BRP. Such repair or replacement of parts will be done without charge for parts and labor, at any authorized Dealer. BRP's responsibility is limited to making the required repairs or replacements of parts with new or BRP-certified re-manufactured parts. No claim of breach of warranty shall be cause for cancellation or rescission of the sale of Product to owner.

In the event that warranty service is required outside of the fifty United States or Canada, owner will bear responsibility for any additional charges due to local practices and conditions, such as, but not limited to, freight, insurance, taxes, license fees, import duties, and any and all other financial charges, including those levied by governments, states, territories and their respective agencies.

BRP reserves the right to improve, modify or change Products from time to time without assuming any obligation to modify Products previously manufactured.

8. Transfer

If the ownership of Product is transferred during the warranty coverage period, this warranty shall also be transferred and be valid for the remaining coverage period provided that BRP is notified of such transfer of ownership in the following way:

1. The former owner contacts BRP (at the phone number provided below) or a Dealer and gives the coordinates of the new owner; or
2. BRP or a Dealer receives a proof that the former owner agreed to the transfer of ownership, in addition to the coordinates of the new owner.

9. Consumer Assistance

- In the event of a controversy or dispute in connection with this BRP limited warranty, BRP recommends that you first try to resolve the issue at the dealership level by discussing the issue with Dealer's service manager or owner;
- If further assistance is required, please contact:

For the United States and Canada:

**BRP US Inc. / Marine Propulsion
Systems,**
After Sales Support
P.O Box 597,
Sturtevant, WI 53177
1-262-884-5993

For the countries within Europe, Middle East, Africa, Russia & CIS

BRP Europe N.V.,
Customer Assistance
Center
SKALDENSTRAAT 125
9042 GENT Belgium
Tel: +32 9 218 26 00

For Scandinavian Countries:

BRP Finland OY
Service Department
Ahjotie 30
Fin-96320 Rovaniemi
Finland
Tel: +358 16 3208 111

**For all other countries, please contact your local Distributor/Dealer or
Contact our Canadian office:**

**Bombardier Recreational
Products Inc.**
Customer Assistance Center
75, J.-A. Bombardier Street
Sherbrooke, Québec J1L 1W3
Canada
Tel.: +1 819 566 3366

You can also find your Distributor's/Dealer's coordinates on www.brp.com.

Additional Terms and Conditions for France Only

The following terms and conditions are applicable to products sold in France only:

The seller shall deliver goods that are complying with the contract and shall be responsible for defects existing upon delivery. The seller shall also be responsible for defects resulting from packaging, assembling instructions or the installation when it is its responsibility per the contract or if accomplished under its responsibility. To be compliant with the contract, the good shall:

1. Be fit for normal use for goods similar thereto and, if applicable:
2.
 - Correspond to the description provided by the seller and have the qualities presented to the buyer through sample or model;
 - Have the qualities that a buyer may legitimately expect considering the public declarations of the seller, the manufacturer of its representative, including in advertising or labeling; or
1. Have the characteristics mutually agreed upon as between the parties or be fit for the specific use intended by the buyer and brought to the attention of the seller and which accepted.

The action for failure to comply is prescribed after two years after delivery of the goods. The seller is responsible for the warranty for hidden defects of the good sold if such hidden defects are rendering the good unfit for the intended use, or if they diminish its use in such a way that the buyer would not have acquired the good or would have given a lesser price, had he known. The action for such hidden defects shall be taken by the buyer within 2 years of the discovery of the defect.

* Engines sold in Canada are distributed and serviced by Bombardier Recreational Products Inc.

* In the European Economic Area and elsewhere, Products are distributed and serviced by BRP European Distribution S.A. and other subsidiaries of BRP.

Limited Warranty Revision August 2014

BRP US Inc. Limited Corrosion Warranty For *Evinrude E-TEC* Engines

What is covered: BRP US Inc. (BRP) warrants that each new *Evinrude E-TEC* engine sold by authorized *Evinrude* dealers ("Product") will not be rendered inoperative as a direct result of corrosion for the period of time described below.

Duration of coverage: This limited corrosion warranty will be in effect from the date of delivery to the first retail consumer or the date the Product is first put to use, whichever occurs first, for a period of five (5) years. The repair or replacement of parts, or the performance of service under this limited corrosion warranty, does not extend the life of this limited corrosion warranty beyond its original expiration date. Unexpired warranty coverage can be transferred to a subsequent (non-commercial use) purchaser upon proper registration of the Product.

Warranty Information

Conditions required for warranty coverage:

This limited corrosion warranty is available **only** if **each** of the following conditions has been fulfilled:

- The Product must be purchased as new and unused by its first owner from an authorized *Evinrude* dealer ("Dealer") authorized to distribute products in the country in which the sale occurred;
- The BRP specified pre-delivery inspection process must be completed and documented and signed by the Dealer and the purchaser ("Owner");
- The Product must have undergone proper registration by a Dealer;
- The Product must be purchased in the country in which the Owner resides;
- Corrosion prevention devices specified in the Operation and Maintenance Manual must be in use on the boat; and
- Routine maintenance outlined in the Operator's Guide and Service Manual must be timely performed (including, without limitation, the replacement of sacrificial anodes, use of specified lubricants, and paint touch-up of nicks and scratches) in order to maintain warranty coverage. BRP reserves the right to make warranty coverage contingent upon proof of proper maintenance by a Dealer.

Exclusions: The following are not warranted under any circumstance:

- Corrosion damage caused by stray electrical currents (on-shore power connections, nearby boats, submerged metal).
- Damage caused by improper application of copper base anti-fouling paints.
- Electrical system corrosion;

- Corrosion resulting from damage,
- Corrosion which causes purely cosmetic damage,
- Abuse, or improper service;
- Corrosion to accessories, instruments, steering systems;
- Damage due to marine growth;
- Replacement parts (parts purchased by Owner);
- Products used in a commercial application. Commercial use is defined as any work or employment related use of the Product, or any use of the Product which generates income, for any part of the warranty period, even if the Product is only occasionally used for such purposes.

If anti-fouling protection is required, Bis (tributyltin) adipate (TBT) base anti-fouling paints are recommended on Evinrude® Evinrude engine boating applications. In areas where TBT base paints are prohibited by law, copper base paints can be used on the hull and transom. Do not apply paint to the Product. In addition, care must be taken to avoid an electrical interconnection between the Product and the paint.

What to do to obtain warranty coverage: The registered Owner must notify an authorized Dealer within two (2) days of the appearance of a defect. BRP is not responsible for damages caused by the use of a Product after the appearance of a defect. Owner must bring Product, including any defective part therein, to Dealer promptly after the appearance of the defect, and in any event, within the warranty period, and must provide Dealer with reasonable opportunity to repair the defect. The expenses of transporting Product to and from Dealer for warranty service are to be borne by the owner.

If the Product has not previously been registered, the Owner may also be required to present proof of purchase to Dealer for warranty repairs. Owner is required to sign the repair work order prior to the start of the repair in order to validate the warranty repair.

All parts replaced under this warranty become the property of BRP.

What BRP will do: BRP's sole and exclusive obligation under this limited corrosion warranty is limited to, at BRP's option, repairing a corroded part, replacing such part or parts with new genuine or Evinrude certified remanufactured parts, or refunding the purchase price of the Product. BRP reserves the right to improve or modify products from time to time without assuming an obligation to modify products previously manufactured.

TRANSFER: If the ownership of Product is transferred during the warranty coverage period, this warranty shall also be transferred and be valid for the remaining coverage period provided that BRP is notified of such transfer of ownership in the following way:

1. The former owner contacts BRP (at the phone number provided below) or a Dealer and gives the coordinates of the new owner; or
2. BRP or a Dealer receives a proof that the former owner agreed to the transfer of ownership, in addition to the coordinates of the new owner.

Consumer Assistance

In the event of a controversy or dispute in connection with this BRP limited corrosion warranty, BRP recommends that you first try to resolve the issue at the dealership level by discussing the issue with Dealer's service manager or owner;

If further assistance is required, please refer to **Consumer Assistance** on page 62 for regional contact information.

* Engines sold in Canada are distributed and serviced by Bombardier Recreational Products Inc.

® Registered trademark of Bombardier Recreational Products Inc. or its affiliates.

© 2014 BRP US Inc. All rights reserved.

US EPA Emission Warranty

BRP US Inc. ("BRP")* warrants to the ultimate purchaser and each subsequent purchaser that this new engine, including all parts of its exhaust emission control system and its evaporative emission control system, meets two conditions:

1. It is designed, built, and equipped so it conforms at the time of sale to the ultimate purchaser with the requirements of 40 CFR 1045 and 40 CFR 1060.
2. It is free from defects in materials and workmanship that may keep it from meeting the requirements of 40 CFR 1045 and 40 CFR 1060.

Where a warrantable condition exists, BRP will repair or replace, as it elects, any part or component with a defect in materials or workmanship that would increase the engine's emissions of any regulated pollutant within the stated warranty period at no cost to the owner, including expenses related to diagnosing and repairing or replacing emission-related parts. All defective parts replaced under this warranty become the property of BRP.

For all emission-related warranty claims, BRP is limiting the diagnosis and repair of emission-related parts to the authorized *Evinrude* dealers, unless for emergency repairs as required by item 2 of the following list.

As a certifying manufacturer, BRP will not deny emission-related warranty claims based on any of the following:

Maintenance or other service BRP or BRP's authorized facilities performed.

Engine/equipment repair work that an operator performed to correct an unsafe, emergency condition attributable to BRP as long as the operator tries to restore the engine/equipment to its proper configuration as soon as possible.

Any action or inaction by the operator unrelated to the warranty claim.

Maintenance that was performed more frequently than BRP specify.

Anything that is BRP fault or responsibility.

The use of any fuel that is commonly available where the equipment operates unless BRP written maintenance instructions state that this fuel would harm the equipment's emission control system and operators can readily find the proper fuel. See maintenance information section and fuel requirements section.

Emission Related Warranty Period

The emission-related warranty is valid for the following period whichever comes first:

	Hours	Months
Exhaust emission-related components	175	60
Evaporative emission-related components	N/A	24

Components Covered

The emission-related warranty covers all components whose failure would increase an engine's emissions of any regulated pollutant, including the following listed components:

1. For exhaust emissions, emission-related components include any engine parts related to the following systems:

- Air-induction system
- Fuel system
- Ignition system
- Exhaust gas recirculation systems

2. The following parts are also considered emission-related components for exhaust emissions:

- After-treatment devices
- Crankcase ventilation valves
- Sensors
- Electronic control units

3. The following parts are considered emission-related components for evaporative emissions:

- Fuel tank
- Fuel cap
- Fuel line
- Fuel line fittings
- Clamps*
- Pressure relief valves*
- Control valves*
- Control solenoids*
- Electronic controls*
- Vacuum control diaphragms*
- Control cables*
- Control linkages*
- Purge valves
- Vapor hoses
- Liquid/vapor separator
- Carbon canister
- Canister mounting brackets
- Carburetor purge port connector

4. Emission-related components also include any other part whose only purpose is to reduce emissions or whose failure will increase emissions without significantly degrading engine/equipment performance.

*As related to the evaporative emission control system

Limited Applicability

As a certifying manufacturer, BRP may deny emission-related warranty claims for failures that have been caused by the owner's or operator's improper maintenance or use, by accidents for which the manufacturer has no responsibility, or by acts of God. For example, an emission-related warranty claim need not be honored for failures that have been directly caused by the operator's abuse of the engine/equipment or the operator's use of the engine/equipment in a manner for which it was not designed and are not attributable to the manufacturer in anyway.

California Emission Control Warranty Statement

Your *Evinrude E-TEC* outboard has a special environmental label required by the California Air Resources Board. The label has one, two, three, or four stars. A hangtag, provided with your outboard, describes the meaning of the star rating system.



The Star Label Means Cleaner Marine Engines

The Symbol for Cleaner Marine Engines:

Cleaner Air and Water

For a healthier lifestyle and environment.

Better Fuel Economy

Burns up to 30 to 40 percent less gas and oil than conventional carbureted two-stroke engines, saving money and resources.

Longer Emission Warranty

Protects consumer for worry free operation.

One Star – Low Emission

The one-star label identifies Personal Watercraft, Outboard, Sterndrive and Inboard engines that meet the Air Resource Board's Personal Watercraft and Outboard marine engine 2001 exhaust emission standards. Engines meeting these standards have 75% lower emissions than conventional carbureted two-stroke engines. These engines are equivalent to the U.S. EPA's 2006 standards for marine engines.

Two Stars – Very Low Emission

The two-star label identifies Personal Watercraft, Outboard, Sterndrive and Inboard engines that meet the Air Resources Board's Personal Watercraft and Outboard marine engine 2004 exhaust emission standards. Engines meeting these standards have 20% lower emissions than One Star – Low Emission engines.

Three Stars – Ultra Low Emission

The three-star label identifies engines that meet the Air Resources Board's Personal Watercraft and Outboard marine engine 2008 exhaust emission standards or the Sterndrive and Inboard marine engine 2003 exhaust emission standards. Engines meeting these standards have 65% lower emissions than One Star – Low Emission engines.

Four Stars – Super Ultra Low Emission

The four-star label identifies engines that meet the Air Resources Board's Stern-drive and Inboard marine engine 2009 exhaust emission standards. Personal Watercraft and Outboard marine engines may also comply with these standards. Engines meeting these standards have 90% lower emission than One Star – Low Emission engines.

Your Emission Control Warranty Rights and Obligation

The California Air Resources Board and Bombardier Recreational Products ("BRP") are pleased to explain the emission control system warranty on your *Evinrude E-TEC* outboard. In California, new outboard engines must be designed, built, and equipped to meet the State's stringent anti-smog standards. BRP must warrant the emission control system on your outboard for the periods of time listed below provided there has been no abuse, neglect, or improper maintenance of your outboard.

Your emission control system may include parts such as the carburetor or fuel injection system, the ignition system, and catalytic converter. Also included may be hoses, belts, connectors, and other emission-related assemblies.

Where a warrantable condition exists, BRP will repair your outboard at no cost to you including diagnosis, parts, and labor provided that such work is performed by an authorized BRP dealer.

Manufacturer's Limited Warranty Coverage

This emission limited warranty covers *Evinrude* outboards certified and produced by BRP for sale in California, that are originally sold in California to a California resident, or subsequently warranty-registered to a California resident. The BRP U.S. and Canada limited warranty conditions for *Evinrude* outboards are still applicable to these models with the necessary modifications.

Select emission control parts of your *Evinrude E-TEC* outboard are warranted from the date of purchase by the first retail consumer or the date the product is first put to use, whichever occurs first, for a period of: 4 years, or for 250 hours of use, whichever occurs first.

However, warranty coverage based on the hourly period is only permitted for outboards equipped with the appropriate hour meters or their equivalent. If any emission-related part on your engine is defective under warranty, the part will be repaired or replaced by BRP.

Parts covered are:

1. Electrical System	4. Air Induction System
A. EMM (Engine Management Module)	A. Reed Valves
B. Spark Plugs and Wires	B. Throttle Body Assembly
C. Ignition Coils	C. Intake Manifold
D. Wiring Harness	5. Oil System
2 Exhaust System	A. Oil Injector

A. Inner Exhaust Housing	B. Oil Lines, Fittings, and Clamps
B. Adapter (Exhaust Manifold)	6. Sensors
C. Megaphone (Inner Exhaust)	A. Air Temperature Sensor
3. Fuel System	B. Crank Position Sensor
A. Fuel Lift Pump	C. Throttle Position Sensor
B. Fuel Supply Pump	D. Water Temperature Sensor
C. Fuel Injectors	E. Thermostat
D. Vapor Separator	7. Gaskets
E. Fuel Lines, Fittings, and Clamps	A. All Emission Component Gaskets

The emission warranty covers damage to other engine components that is caused by the failure of a warranted part.

The BRP Operator's Guide provided contains written instructions for the proper maintenance and use of your outboard. All emission warranty parts are warranted by BRP for the entire warranty period of the outboard, unless the part is scheduled for replacement as required maintenance in the Operator's Guide.

Emission warranty parts that are scheduled for replacement, as required maintenance, are warranted by BRP for the period of time before the first scheduled replacement date for that part. Emission warranty parts that are scheduled for regular inspection but not regular replacement are warranted by BRP for the entire warranty period of the outboard. Any emission warranty part repaired or replaced under the terms of this warranty statement is warranted by BRP for the remainder of the warranty period of the original part. All parts replaced under this limited warranty become the property of BRP.

Maintenance receipts and records should be transferred to each subsequent owner of the outboard.

Owner's Warranty Responsibilities

As the outboard owner, you are responsible for the performance of the required maintenance listed in your Operator's Guide. BRP recommends that you retain all receipts covering maintenance on your outboard, but BRP cannot deny warranty solely for the lack of receipts or your failure to ensure the performance of all scheduled maintenance.

As the outboard owner, you should however be aware that BRP may deny you warranty coverage if your outboard or a part has failed due to abuse, neglect, improper maintenance, or unapproved modifications.

You are responsible for presenting your outboard to an authorized BRP dealer as soon as a problem exists. The warranty repairs will be completed in a reasonable amount of time, not to exceed 30 days.

For any questions regarding your warranty rights and responsibilities or for the name and location of the nearest authorized BRP dealer, contact:

BRP US Inc. / Marine Propulsion Systems

After Sales Support, P.O. Box 597

Sturtevant, WI 53177

1-262-884-5993

or visit www.brp.com

Readiness Test

The Operator's Readiness Test....

1. Did you read this Guide from front cover to rear cover?
2. Are you ready to take responsibility for the safe operation of your boat and outboard?
3. Do you understand all the safety precautions and instructions contained in this Guide?
4. Do you understand that this Guide contains essential information to help prevent personal injury and damage to equipment?
5. Are you ready to follow the recommendations in this Guide and take a boating safety course before you operate your boat and outboard?
6. Do you know who to ask if you have any questions about your boat and outboard?
7. Do you know your local marine traffic laws?
8. Do you understand that human error can be caused by carelessness, fatigue, overload, preoccupation, unfamiliarity of operator with the product, drugs and alcohol, just to name a few?

WARNING

It is impossible for this Guide to cover every hazardous situation you may encounter; however, your understanding of and adherence to essential information contained in this Guide will build good judgment when boating. Always be alert and careful: a good foundation for safety.

Frequently Asked Questions

No dealer-scheduled maintenance for five years or 500 hours of normal recreational use? Really?

- Yes! BRP knows you want to spend your time out on the water, not servicing your *Evinrude E-TEC* outboard. There are no valves to adjust, belts to service, chains to replace, or oil to change. We do recommend pre-launch inspections of your outboard at each use and at regular intervals. Salt water applications require minimal additional inspections and lubrication.

What fuel octane is recommended for my Evinrude E-TEC outboard?

- *Evinrude E-TEC* outboards require a minimum octane rating 87 {AKI (R+M)/2} in the U.S. and Canada, or 90 {RON} outside of the U.S. and Canada. Use of higher octane fuels is not harmful, but also not necessary.

What kind of oil does my Evinrude E-TEC outboard require?

- *Evinrude XD100* Direct Injection 2–Stroke Oil is recommended for your *Evinrude E-TEC* outboard. When operating in conditions under 32°F (0°C), *Evinrude XD100* oil must be used.

Do I need to mix oil into my fuel?

- **No.** *Evinrude E-TEC* outboards do not require any mixing of oil and fuel.

Can I order replacement parts and accessories for my Evinrude E-TEC outboard?

- Yes. When replacement parts are required, use *Evinrude* Genuine Parts or parts with equivalent characteristics, including type, strength, and material. Using substandard parts could result in injury or product malfunction. Your dealer can order the parts and accessories you desire.

Do I need to complete any paperwork when I move or sell my Evinrude E-TEC outboard?

- Yes. In order to maintain contact with you or the new *Evinrude E-TEC* owner, BRP requests you complete the form outlining **Change of Address / Change of Ownership**. This will ensure you or the new owner is made aware of any product announcements and keep the warranty coverage up-to-date.

What do I need to do before storing my Evinrude E-TEC outboard for the winter?

- Winterization is minimal. Refer to *STORAGE* for step-by-step instructions to store your *Evinrude E-TEC* outboard for the off-season.

Change of Address/Ownership

If your address has changed or if there has been a change of ownership, be sure to fill out and mail the form provided on this page.

This notification is necessary for your own safety even after expiration of the original warranty, since BRP will be in a position to contact you if correction to your outboard is required. Outside the U.S. and Canada, this card should be sent to the Bombardier Recreational Products division where the outboard was registered. Please contact your Dealer or Distributor.



Change of Address Change of Ownership

Model number

Serial Number

Old Address / Previous Owner

Last name

First name M.I.

Address

City State

Zip code Country

Phone number

Signature _____ Date _____

New Address / New Owner

Type of Use Recreational Commercial Government

Last name

First name M.I.

Address

City State

Zip code Country

Phone number

Signature _____ Date _____

Dealer Information

Dealer name

Dealer number

Phone number

Contact name

In the U.S. or Canada, mail completed form to: BRP US Inc. / Marine Propulsion Systems
 After Sales Support
 P.O Box 597
 Sturtevant, WI 53177

Confirmation of Receipt

Your Dealer

Name:	_____
Address:	_____

Upon delivery of your new *Evinrude* outboard, complete and sign the form below. Your Dealer will take receipt of the form for their records.



Receipt

Name:	_____
Address:	_____

Owner of Model No:	_____
Serial No:	_____
(To be completed by customer or selling Dealer)	
The Dealer named on this document has instructed me on the operation, maintenance, safety features and warranty policy, all of which I understand and agree to be bound with. I am also satisfied with the predelivery set-up and inspection of my <i>Evinrude</i> outboard. I have also received a copy of the Operator's Guide.	
Signature:	_____
Date:	_____

⚠ WARNING

This product can expose you to chemicals including gasoline engine exhaust, which is known to the State of California to cause cancer, and carbon monoxide, which is known to the State of California to cause birth defects or other reproductive harm. For more information go to www.p65warnings.ca.gov

www.brp.com



SKI-DOO®

LYNX®

MANITOU®

SEA-DOO®

EVINRUDE®

ALUMACRAFT®

CAN-AM®

ROTAX®