

Operator's Guide
55 HORSEPOWER MFE



FEATURES AT A GLANCE

Easy to Own and Operate

- Multi-Fuel Capable
- De-Watering System
- Carrying Handle
- Low Reflection Paint and Decals
- Tilt-Assist Cylinder
- One-Year Limited Warranty
- No Operational Break-In Procedure
- Easy Starts (no choking or priming)
- Self Flushing Cooling System
- Simplified Winterization Procedure
- Digital Diagnostics
- CANbus Capable

Durable and Reliable

- Full Corrosion Protection
- Multi-Point Lubrication System
- Auto-Calibrated Linkage
- Robust, Heavy-Duty Design
- Posi-Lock Latches
- Extra Capacity Water Pump
- Iridium Spark Plugs
- Vibration Isolated Electronics
- Beltless 25 Amp Charging System
- Stainless Steel Thermostat
- Nickel/Chrome-Faced Piston Rings
- Micro Finished Connecting Rods/Crankshaft
- MFE S.A.F.E. Warning System—maximum engine operation in critical situations

Cleaner and Quieter

- EPA Emissions Compliance
- European Union Emissions Compliance
- Sealed Fuel System
- Low Friction Design (No powerhead gears, belts, cams, oil scraping rings, or mechanical oil pump)
- Full Length Insulated Lower Pans
- Quiet Signature Sound
- Air Intake/Silencer
- Idle Air Bypass

The following trademarks are the property of Bombardier Recreational Products Inc. or its affiliates:

Evinrude®

Evinrude®/Johnson® XD30™

I-Command™

Evinrude® E-TEC®

Evinrude®/Johnson® XD50™

S.A.F.E.™

Evinrude®/Johnson® Genuine Parts

Evinrude®/Johnson® XD100™

SystemCheck™

BRP Logo

HPF XR™ Gearcase Lubricant

Triple-Guard™ Grease

Evinrude® MFE

HPF Pro™ Gearcase Lubricant

2+4™ Fuel Conditioner

TABLE OF CONTENTS

About This Guide	4
Important Safety Messages	5
Product References, Illustrations and Specifications	7
Declaration of Conformity	8
 Using The <i>Evinrude MFE</i> Outboard	
Component Identification	10
Fuel and Oil	13
Fuel Requirements	13
Fuel System Operation	14
Fuel System Priming	14
Fuel Selector Switch	14
Oil Requirements	15
Filling the Oil Tank	15
Priming the Oil System	15
Oiling System Operation	15
Operation	16
Safety Information	16
Engine Starting	16
Engine Stopping	19
Shifting and Speed Control	19
Fuel Economy	20
Engine Overheating	21
Tilting and Trim	22
Tilting	22
Trim Angle Adjustment	23
Impact Damage Protection	24
Transporting the Outboard	25
Trailing	25
Transporting / Storage	25
Special Operating Conditions	26
Cold and Freezing Weather	26
High Altitude	26
Salt Water	26
Shallow Water	27
Towing	27
Weedy Water	27
Submersion and Recovery	28
De-Water Procedure	28
Post-Submersion Servicing	29
Prolonged Submersion	29

Maintenance

Engine Emissions Information	32
Maintenance Schedule	33
Service	34
Anti-Corrosion Anodes	34
Flushing	34
De-Carboning Procedure	35
Fuse	36
Spark Plugs	36
Storage	37
Short-Term Storage	37
Long-Term Storage (Winterization)	38
Pre-Season Check	39
Troubleshooting	40

Product Information

Installation	42
Transom Height	42
Installing the Outboard	43
Propeller – MRL Models	44
Impeller – MJRL Models	45
Tiller Handle Attachment	46
Adjustments	47
Idle RPM in Gear	47
Steering Friction	47
Trim Tab (Propeller models)	47
Specifications	48
Product Warranty Information	49
Change of Address / Change of Ownership	53
Confirmation of Receipt	55

ABOUT THIS GUIDE

This Operator's Guide is an essential part of your *Evinrude MFE* outboard. It contains pertinent information which, if followed, will provide you with a thorough understanding needed for proper operation, maintenance, care, and—above all—safety. Safety is our first priority and it should be yours too. It is strongly recommended you read this Guide from cover to cover. The more you know and understand about your *Evinrude MFE* outboard, the greater the safety and pleasure you will get from using it. Following this recommendation will assure the completeness of the information essential to your safety, the safety of any passengers, and other water users.

This Operator's Guide identifies important safety messages.

Although the mere reading of such information does not eliminate the hazard, the understanding and application of the information will promote the correct use of your outboard engine.

Safety Alert Symbol

This is the Safety Alert symbol. It is used to alert you to potential personal injury hazards. Obey all safety messages that follow this symbol to avoid possible injury or death.

This Guide should be kept in a waterproof bag with the outboard at all times during operation. If the product ownership is transferred, this Guide should be forwarded to the new owners.

A responsible, educated boater will fully appreciate the pleasures of boating and will be a safe boater. Boating Safety Classes are conducted by the U.S. Coast Guard Auxiliary, the U.S. Power Squadron and some Red Cross Chapters. For information about classes, call toll free 1-800-336-BOAT.

For additional information about boating safety and regulations, call:

- U.S. Coast Guard Boating Safety Hotline
1-800-368-5647.

Outside North America please contact your Dealer or distributor for details about boating safety.

This Operator's Guide uses the following signal words identifying important safety messages.

DANGER

Indicates a hazardous situation which, if not avoided, will result in death or serious injury.

WARNING

Indicates a hazardous situation which, if not avoided, could result in death or serious injury.

 **CAUTION** Indicates a hazardous situation which, if not avoided, could result in minor or moderate injury.

 **NOTICE** Indicates an instruction which, if not followed, could severely damage engine components or other property.

IMPORTANT: Identifies information that will help with assembly and operation of the product.

IMPORTANT SAFETY MESSAGES

This Operator's Guide contains essential information to help prevent personal injury and damage to equipment. Safety messages appear throughout this Guide in the applicable section.

Be careful! Human error is caused by many factors: carelessness, fatigue, overload, pre-occupation, unfamiliarity of operator with the product, drugs and alcohol to name a few. Damage to your boat and outboard can be fixed in a short period of time, but injury or death, has a lasting effect.

WARNING

For your safety and the safety of others, follow all safety warnings and recommendations. Do not disregard any of the safety precautions and instructions.

Anyone operating your boat should first read and understand this guide before they operate your boat and outboard.

SAFETY MEASURES — General

- To fully appreciate the pleasures, enjoyment and excitement of boating there are some basic rules that should be observed and followed by any boater. Some rules may be new to you and others may be common sense or obvious... irrespective, take them seriously!
- Be sure at least one of your passengers knows how to handle your boat in case of an emergency.
- All passengers should know the location of emergency equipment and how to use it.
- Know the marine traffic laws and obey them.
- All safety equipment and personal floatation devices must be in good condition and suitable for your type of boat. Always comply with the regulations that apply to your boat.
- Remember, gasoline fumes are flammable and explosive. Always adhere to the fueling procedure contained in this Operator's Guide and those given to you by the fueling station. Always verify fuel level before use and during the ride. Apply the principle of 1/3 fuel to destination, 1/3 back and 1/3 reserve fuel supply. Do not carry spare fuel or flammable liquids in any storage or engine compartments.
- Whenever running the engine, assure there is proper ventilation to avoid the accumulation of carbon monoxide (CO), which is odorless, colorless, and tasteless, and can lead to unconsciousness, brain damage, or death if inhaled in sufficient concentrations. CO accumulation can occur while docked, anchored, or underway, and in many confined areas such as the boat cabin, cockpit, swim platform, and heads. It can be worsened or caused by weather, mooring and operating conditions, and other boats. Avoid exhaust fumes from your engine or other boats, provide proper ventilation, shut off your engine when not needed, and be aware of the risk of backdrafting and conditions that create CO accumulation. In high concentrations, CO can be fatal within minutes. Lower concentrations are just as lethal over long periods of time.
- Avoid standing up or shifting weight suddenly in light weight boats.
- Keep your passengers seated in seats. The boat's bow, gunwale, transom and seat backs are not intended for use as seats.
- Insist on the use of personal floatation devices, approved by the U.S. Coast Guard, by all passengers when boating conditions are hazardous, and by children and nonswimmers at all times.
- Proceed with caution and at very low speed in shallow water. Grounding or abrupt stops may result in personal injury or property damage. Also be alert for debris and objects in the water.

SAFETY MEASURES — Installation and Maintenance

- Be familiar with the waters you are operating in. The gearcase of this outboard extends below the water surface and could potentially come in contact with underwater obstructions. Contact with underwater obstructions may result in loss of control and personal injury.
- Respect no wake zones, rights of other water users and the environment. As the "skipper" and owner of a boat you are responsible for damage to other boats caused by the wake of your boat. Allow no one to throw refuse overboard.
- Do not operate your boat if you are under the influence of drugs or alcohol.
- High performance boats have a high power-to-weight ratio. If you are not experienced in the operation of a high performance boat, do not attempt to operate one at, or near, its top speed until you have gained that experience.
- Become completely familiar with the control and operation of your boat and outboard before embarking on your first trip or taking on a passenger(s). If you have not had the opportunity to do so with your Dealer, practice driving in a suitable area and feel the response of each control. Be familiar with all controls before applying the throttle above idle speed. As the operator, you are in control and responsible for safe operation.
- The outboard must be correctly installed. Failure to correctly install the outboard could result in serious injury, death or property damage. We strongly recommend that your Dealer install your outboard to ensure proper installation.
- Do not overpower your boat by using an engine that exceeds the horsepower indicated on the boat's capacity plate. Overpowering could result in loss of control. If your boat has no capacity plate, contact your Dealer or the boat's manufacturer.
- When replacement parts are required, use *Evinrude/Johnson Genuine Parts* or parts with equivalent characteristics, including type, strength and material. Using substandard parts could result in injury or product malfunction.
- Only perform service procedures which are detailed in this Operator's Guide. Attempting to perform maintenance or repair on your outboard if you are not familiar with the correct service and safety procedure could cause personal injury or death. Further information can be obtained from your authorized *Evinrude/Johnson* Dealer. In many instances proper tools and training are required for certain service or repair procedures.
- Maintain your boat and engine in top condition at all times. Adhere to the **Maintenance Schedule** on page 33.
- Operate your boat and outboard prudently and have fun. Do not forget that all persons must assist other boaters in case of emergency.
- Prevent injury from contact with rotating propeller; remove propeller before flushing or before performing any maintenance.

PRODUCT REFERENCES, ILLUSTRATIONS AND SPECIFICATIONS

BRP reserves the right to make changes at any time, without notice, to features, specifications and model availability, and to change any specification or part at any time without incurring any obligation to update older models. The information in the Guide is based on the latest specifications available at the time of publication.

Photographs and illustrations used in this Guide might not depict actual models or equipment but are intended as representative views for reference only.

Certain features of systems discussed in this Guide might not be found on all models in all marketing areas.

Owner's Identification

United States and Canada — At the time of purchase, your Dealer will complete your outboard registration forms. Your portion provides proof of ownership and date of purchase.

Outside United States and Canada — See your Dealer or distributor for details.

Model and Serial Numbers

The model and serial numbers appear on a plate attached to the stern bracket or swivel bracket. Record your outboard's:

Model Number _____

Serial Number _____

Purchase Date _____

Date of Delivery _____

Ignition Key Number _____

Stolen Outboards

United States and Canada — Report stolen outboards to your local dealer or distributor.

Outside United States and Canada — Report the theft to the Bombardier Recreational Products distributor where the outboard was registered.

Technical Literature

BRP offers technical literature specifically for your outboard. A service manual, or an extra Operator's Guide can be purchased from your selling Dealer. For the name and location of the nearest *Evinrude* Dealer in the United States and Canada visit www.evinrude.com.

DECLARATION OF CONFORMITY

• Application of Council Directives and their relevant harmonized standard(s):

Recreational Craft Directive 94/25/EC as amended by 2003/44/EC

- EN ISO 8178-1:1996
- EN ISO 14509

Electromagnetic Compatibility Directive 2004/108/EC

- EN 55012:2007
- EN 61000-6-1:2007
 - EN 61000-4-2:2008
 - EN 61000-4-3:2006

Machinery Directive 2006/42/EC

- ISO 12100:2010

• Product Type:

Marine Outboard 2-Stroke Cycle SI Engine sold under the *Evinrude* name

Manufacturer:

BRP US Inc
10101 Science Drive
Sturtevant, WI, USA 53177

Authorized Representative:

BRP Europe N.V.
Geert De Brandt, Operations Manager
Skaldenstraat 125
Gent, Belgium, B-9042

I, the undersigned, hereby declare that the product conforms to the above Directive(s) and Standard(s).



George Broughton
Director of Engineering – Outboards

Using The *Evinrude MFE* Outboard

COMPONENT IDENTIFICATION

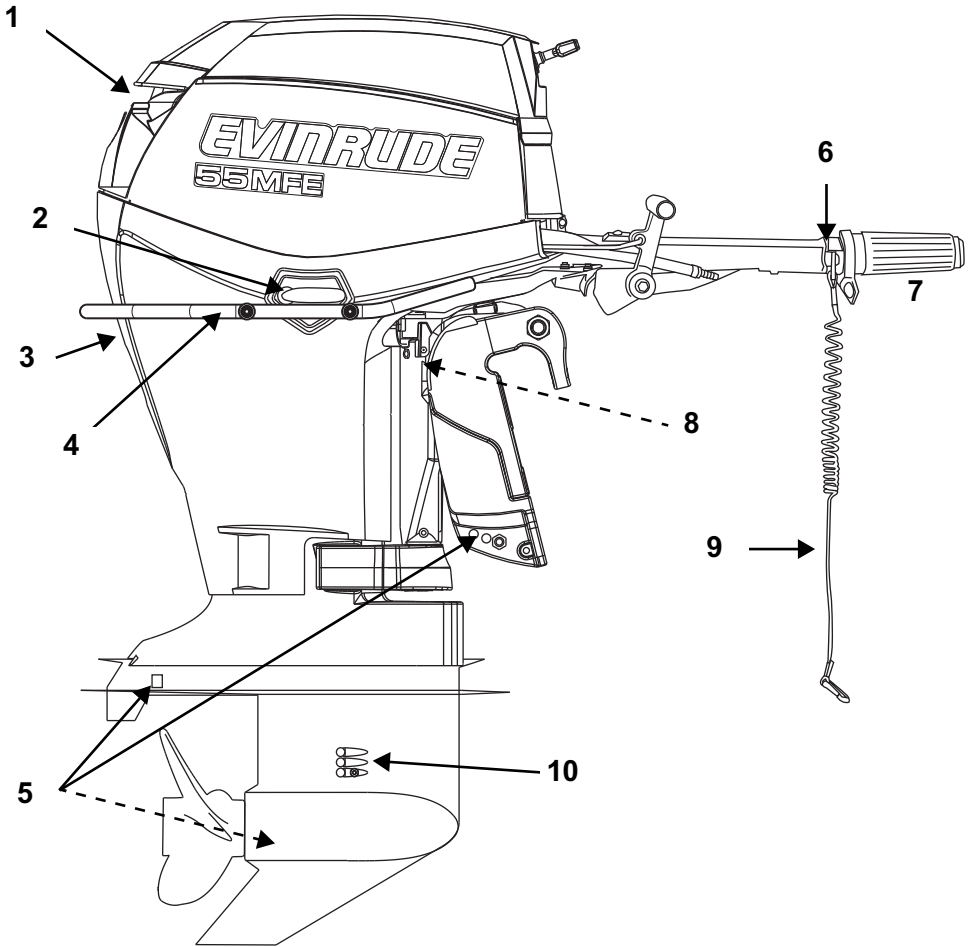

006607

Item	Description	Item	Description
1	Air Inlet, Tilt Handle	6	Stop Button / Engine Cut-off Switch
2	Engine Cover Latch	7	Steering Handle & Throttle
3	Water Pump Indicator, Flushing Port	8	Tilt Support
4	Carry Handle	9	Clip and Tether Cord Assembly
5	Anti-Corrosion Anodes	10	Water Intake Screens

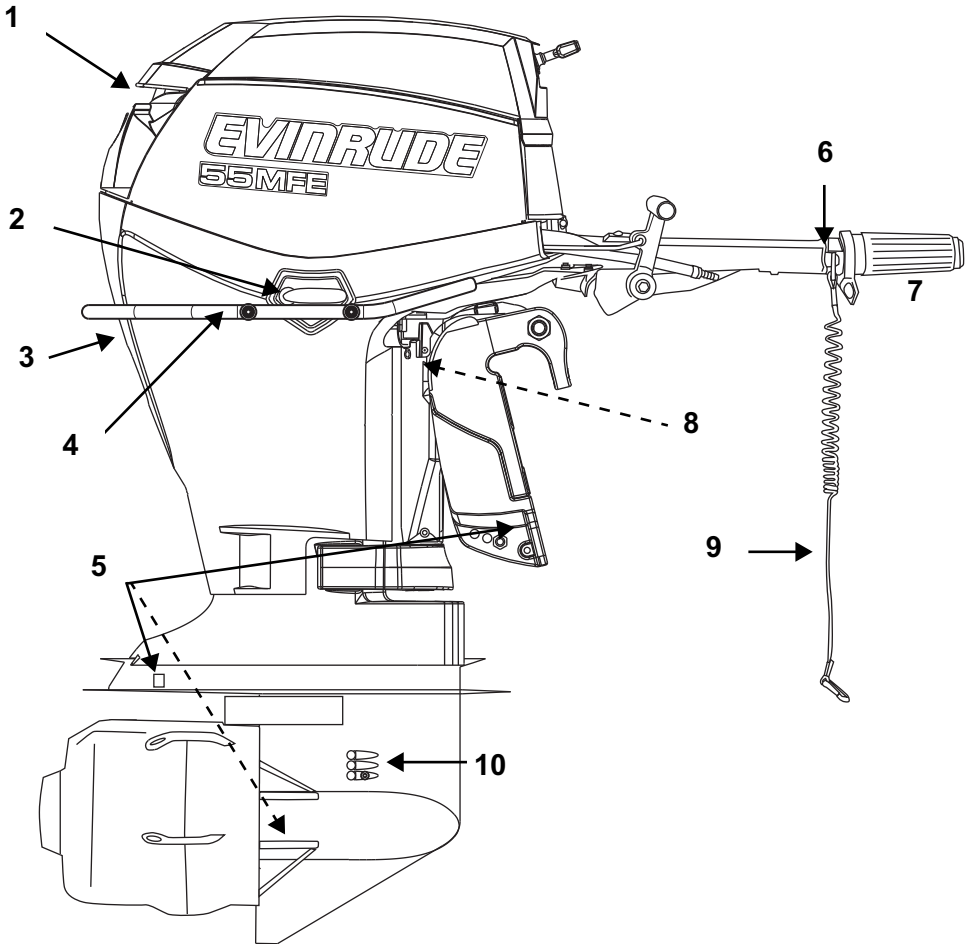

006608

Item	Description	Item	Description
1	Air Inlet, Tilt Handle	6	Stop Button / Engine Cut-off Switch
2	Engine Cover Latch	7	Steering Handle & Throttle
3	Water Pump Indicator, Flushing Port	8	Tilt Support
4	Carry Handle	9	Clip and Tether Cord Assembly
5	Anti-Corrosion Anodes	10	Water Intake Screens

Using The Evinrude MFE Outboard

Starboard

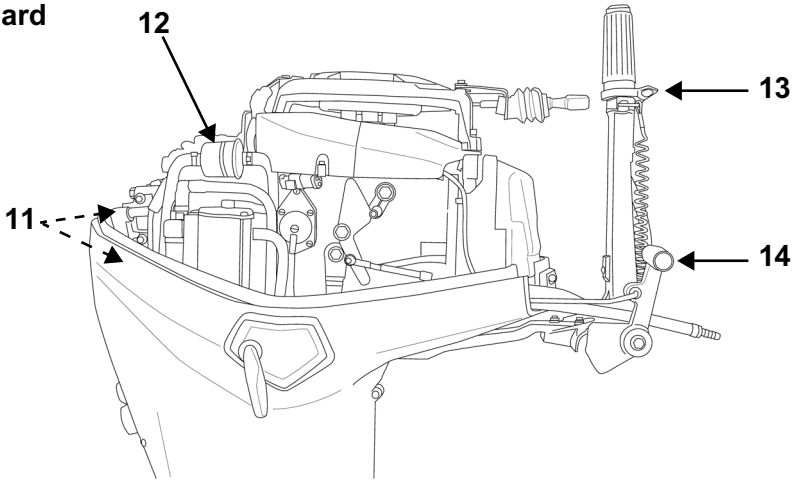

Port

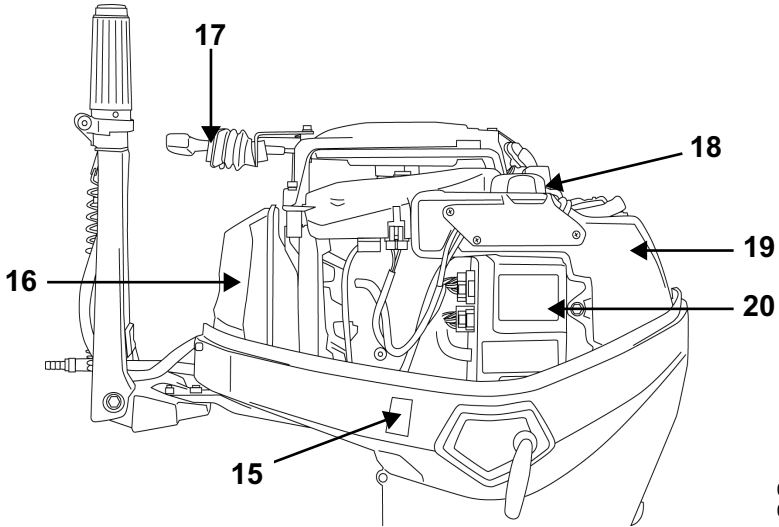

002404
002400

Item	Description	Item	Description
11	Spark Plugs	16	Air Silencer
12	Fuel Filter	17	Starter Handle
13	Throttle Friction Screw	18	Oil Fill Cap
14	Shift Lever	19	Oil Tank
15	Fuel Selector Switch	20	EMM (Engine Management Module)

FUEL AND OIL

FUEL REQUIREMENTS

⚠ WARNING

Gasoline is extremely flammable and highly explosive under certain conditions. Follow the instructions in this section explicitly. Improper handling of fuel could result in property damage, serious injury or death.

Leaking fuel is a fire and explosion hazard. All parts in the fuel system should be inspected frequently and replaced if signs of deterioration or leakage are found. Inspect the fuel system each time you refuel, each time you remove the engine cover and annually.

Follow these instructions to ensure safety when handling fuel:

- Always turn off the engine before fueling.
- Never permit anyone other than an adult to refill the fuel tank.
- Do not fill the fuel tank all the way to the top or fuel may overflow when it expands due to heating by the sun.
- Remove portable fuel tanks from the boat before fueling.
- Always wipe off any fuel spillage.
- Do not smoke, or allow open flames, or sparks or use electrical devices such as cellular phones in the vicinity of a fuel leak or while fueling.
- Always work in a well ventilated area.

Evinrude MFE models are designed to use several different fuel types. Refer to **Fuel Selector Switch** on page 14.

Heavy Fuels

Approved heavy fuels include:

- JP5, JP8
- Jet A
- Kerosene

IMPORTANT: *Evinrude/Johnson XD100* outboard oil **MUST** be used when outboard is run on heavy fuels. **DO NOT** use Diesel DFM-F76 or BioDiesel fuels. For combat emergency situations see **Emergency Fuel** on p. 13.

Gasoline

Use fresh, unleaded automotive gasoline with the following octane rating:

Minimum Octane Rating	
Inside North America	87 (R+M)/2 AKI
Outside North America	90 RON

Use unleaded gasoline that contains methyl tertiary butyl ether (MTBE) **ONLY** if the MTBE content does not exceed 15% by volume.

Alcohol-extended fuel is acceptable **ONLY** if the alcohol content does not exceed:

- 10% ethanol by volume; or
- 5% methanol with 5% cosolvents by volume.

Emergency Fuel

In a combat emergency when no other fuel is available, diesel DFM-F76 or BioDiesel can be used. Operating time should be limited to the duration of the combat emergency and the operator should return to operating on one of the approved fuels as soon as possible.

Idle and low speed operation (below 3000 RPM) should be avoided to prevent spark plug fouling when operating on diesel DFM-E76 or BioDiesel.

IMPORTANT: If the outboard **MUST** be run on diesel, the de-carbon procedure **MUST** be performed immediately after return from the mission. Refer to **De-Carboning Procedure** on p. 35.

Fuel Additives (gasoline only)

The only fuel additives approved for use are:

- *Evinrude/Johnson 2+4 Fuel Conditioner*
- *Evinrude/Johnson Fuel System Cleaner*

Use of other fuel additives can result in poor performance or engine damage.

Evinrude/Johnson 2+4 Fuel Conditioner will help prevent gum and varnish deposits and will remove moisture from the fuel system. It can be used continuously and should be used during any period when the outboard is not being operated on a regular basis.

Evinrude/Johnson Fuel System Cleaner helps keep fuel injectors in good condition.

FUEL SYSTEM OPERATION

⚠ WARNING

If engine is equipped with a quick-disconnect fuel hose, you **MUST** disconnect the fuel hose from the engine and the fuel tank to prevent fuel leaks:

- Whenever the engine is **NOT** being used
- Whenever the engine is being trailered
- Whenever the engine is in storage

NOTE: A small amount of fuel may be released when the fuel connector is disconnected.

Store portable fuel tanks in well-ventilated areas, away from heat sources and open flames. Close the vent screw of the fuel tank cap, if equipped, to prevent escape of fuel or fuel vapors which could accidentally ignite. Do not allow disconnected fuel hoses to leak fuel.

IMPORTANT: The minimum inside diameter of the fuel hose from the fuel tank to the outboard must be 3/8 in. (9 mm). Be sure the boat's fuel system provides adequate fuel to the outboard. Fuel systems with anti-siphon valves, filters or primer units may restrict fuel flow to the outboard and effect engine performance.

FUEL SYSTEM PRIMING

If the outboard is run out of fuel, refill the fuel tank and squeeze the primer bulb until firm. The high pressure fuel circuits and injectors will prime as the outboard is cranked with the starter.

FUEL SELECTOR SWITCH

NOTICE Operation with the fuel selector switch in the wrong position could cause internal engine damage not covered by the outboard's limited warranty

The *Engine Management Module (EMM)* includes programs allowing the engine to run on several types of fuel. You **MUST** select the correct program for the fuel being used. Refer to **Fuel Requirements** on p. 13.

- To use jet fuel, or kerosene, press the fuel selector switch **IN**.
- To use gasoline, pull the fuel selector switch **OUT** to expose the red indicator ring.

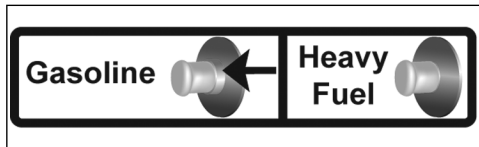

006550

When switching from one fuel to another:

- Connect the fuel supply hose to the desired fuel supply.
- Adjust the selector switch on the port side of the outboard for the new fuel.
- Restart the engine to reset the *EMM*—changing the switch has no effect while the engine is running.
- The *EMM* calculates when the previous fuel remaining in the engine has been used and switches the program at that time.
- The engine may run noticeably rough during the transition period.

IMPORTANT: Diesel fuel should be used as an emergency fuel **ONLY**. If diesel fuel must be used, the fuel selector switch should be in the Heavy Fuel position. Refer to **Emergency Fuel** on p. 13 and **De-Carboning Procedure** on p. 35.

OIL REQUIREMENTS

Evinrude/Johnson XD100 is the **ONLY** outboard oil recommended for use with *Evinrude MFE* outboards. *Evinrude/Johnson XD100* outboard oil **MUST** be used when outboard is run on heavy fuels. *Evinrude/Johnson XD100* oil **MUST** be used when operating in temperatures under 32°F (0°C).

In combat emergency if *Evinrude/Johnson XD100* oil is not available, you must use an oil that meets NMMA TC-W3 certification standards. Operating time should be limited to the duration of the combat emergency and the operator should return to operating on *Evinrude/Johnson XD100* as soon as possible.

IMPORTANT: Failure to follow oil specifications could void the engine warranty if a lubrication-related failure occurs.

FILLING THE OIL TANK

Remove the engine cover to access the oil tank. Remove the filler cap and fill the tank with the recommended outboard lubricant. The oil tank capacity is 2.0 quarts (1.9 liters)

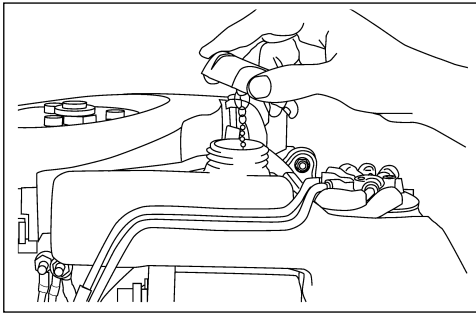

002007

Replace the filler cap and tighten securely. Reinstall the engine cover.

PRIMING THE OIL SYSTEM

The oiling system must be primed before using the outboard if:

- The outboard is new;
- You run completely out of oil; or
- The outboard is laid down for transportation or storage.

If available, use the *Evinrude* Diagnostics Software program oil priming function for a minimum of 90 seconds.

If the diagnostics program is not available, prime the oiling system by using the winterization procedure. Refer to **Long-Term Storage (Winterization)** on page 38.

Observe oil flow through the oil distribution hoses.

Small bubbles are acceptable. Large bubbles must be eliminated through continued priming.

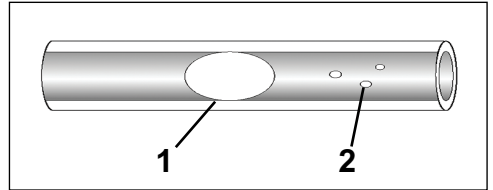

1. Large bubble
2. Small bubbles

004398

OILING SYSTEM OPERATION

Break-In

New outboards are programmed to use additional oil during the first two hours of operation above 2000 RPM. No other action is required by the operator.

IMPORTANT: DO NOT add oil in the fuel tank.

NO OIL Warning System

When the level in the oil tank falls below one-quarter:

- The *EMM* interrupts the ignition once per 50 engine revolutions to signal the operator.
- The *EMM* then calculates remaining oil level based on oil pump pulse cycles. When it determines the oil has been used, the *EMM*:
- Limits engine speed to 2500 RPM.

To recover from NO OIL mode, stop the outboard and add oil to tank. The warning resets after the pump cycles for a minimum of three pulses with the oil level above one-quarter.

OPERATION

SAFETY INFORMATION

⚠ DANGER

Serious injury or death can result from contact with a rotating propeller or moving boat and outboard.

Blades can be sharp and the propeller can continue to turn even after the engine is off.

Assure the engine propeller area is clear of people and objects before starting engine or operating the boat.

Be alert of people in the water.

Always shift the outboard to **NEUTRAL** and shut off the engine immediately when your boat is in an area where there might be people in the water.

⚠ DANGER

DO NOT run the engine indoors or without adequate ventilation or permit exhaust fumes to accumulate in confined areas. Engine exhaust contains carbon monoxide which, if inhaled, can cause serious brain damage or death.

⚠ WARNING

The engine cover is a machinery guard. **DO NOT** operate your outboard with the cover off unless you are performing maintenance or emergency starting, and then be careful to keep hands, hair, and clothing clear of all moving parts. Contact with moving parts could cause injury

⚠ WARNING

Be familiar with the waters you are operating in. The gearcase of this outboard extends below the water surface and could potentially come in contact with underwater obstructions. Contact with underwater obstructions may result in loss of control and personal injury.

ENGINE STARTING

Before starting the outboard:

- Check fuel and oil levels
- Make sure fuel selector switch is in the correct position for the fuel being used.
- Move the tilt/run lever to the RUN position

NOTICE You **MUST** supply water to the engine before starting. Water pump damage can occur in just a few seconds.

Be sure the water intake screens are below the water surface.

Connection the Fuel Hose

Connect the fuel hose to fuel connector.

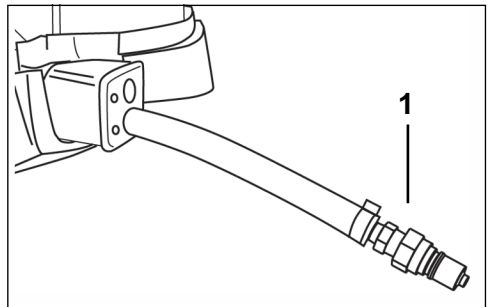

1. Fuel connector

002018M

If equipped, open vent screw on fuel tank cap.

Squeeze fuel primer bulb, outlet end up, until firm.

Engine Cut-off Switch

The engine cut-off switch is on the steering handle. Use of the engine cut-off feature is highly recommended on all boats.

Connect the clip to the engine cut-off switch.

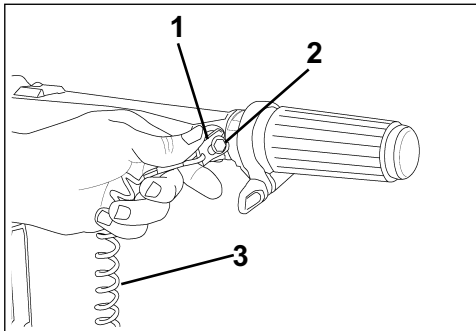

1. Clip
2. Engine cut-off switch / clip
3. Tether cord

002405

An extra clip is stored on the tiller handle. If the operator is thrown from the boat, another person can insert the extra clip in the engine cut-off switch and start the outboard.

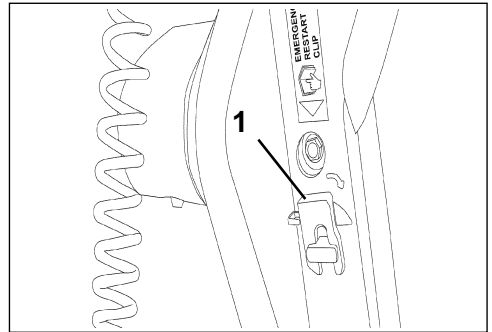

1. Extra clip

005105

▲ WARNING

Always use the tether cord when operating your boat to help prevent a runaway boat and reduce the risk of personal injury or death.

Snap the tether cord to a **secure** place on the operator's clothing or life vest — not where it might tear away instead of activating the engine cut-off switch.

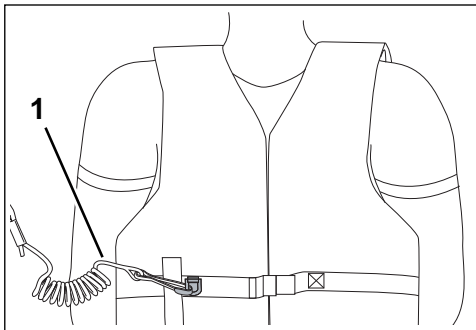

1. Tether cord

008489

Disconnecting the clip and tether cord will stop the engine and prevent the boat from becoming a runaway if the driver moves beyond the range of the tether cord. If the tether cord is too long, it can be shortened by knotting or looping it. **DO NOT** cut and retie the tether cord.

▲ WARNING

Avoid knocking or pulling the clip off the engine cut-off switch during normal boating. The resulting unexpected loss of forward motion can throw occupants forward, causing injury.

Keep the tether cord free from obstructions and entanglements.

At each outing, test the system's operation. With the engine running, remove the clip from the switch by pulling the tether cord. If the engine does not stop running, see your Dealer.

NOTICE Carefully check the function of all control and engine systems before leaving the dock. **DO NOT** shift the engine into **FORWARD** or **REVERSE** while it is shut off.

Using The Evinrude MFE Outboard

Move the shift lever to NEUTRAL. Refer to **Shifting and Speed Control** on page 19. The engine will NOT start in gear.

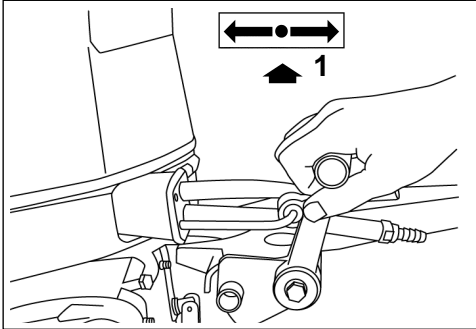

1. NEUTRAL

002415

⚠ WARNING

Always shift to NEUTRAL before starting the outboard to prevent sudden boat movement, which can cause injury.

Twist throttle grip to **SLOWEST** speed position.

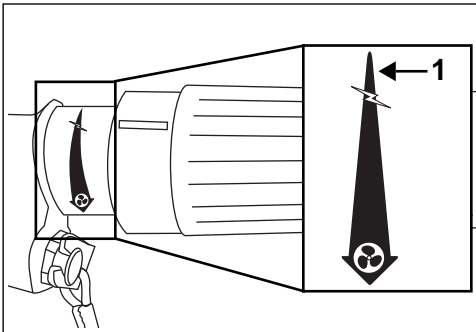

1. SLOWEST speed position

007067

DO NOT advance the throttle before start-up. Advancing the throttle overrides the electronic idle control system.

If the outboard is started with the throttle advanced, the outboard will be in a safety mode. It will not respond to throttle until the throttle twist grip is returned to slowest speed position.

After the engine starts, the engine management module (EMM) automatically increases idle speed slightly. Idle speed will decrease as the engine warms up.

While seated, pull starter handle slowly until starter engages, then pull hard. Short or slow pulls may not provide enough energy to start the engine.

Repeat, if needed, until outboard starts.

NOTICE To prevent damage to starter assembly, allow starter cord to rewind before releasing starter handle.

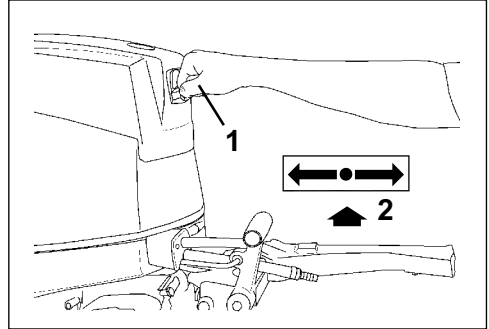

1. Starter handle
2. NEUTRAL

002416

If the outboard does not start, refer to **Troubleshooting** on page 40.

After Engine Starts

Check the water pump indicator. A steady stream of water indicates the water pump is working. If a steady stream of water from the water pump indicator is not visible, stop the engine. Refer to **Engine Overheating** on page 21.

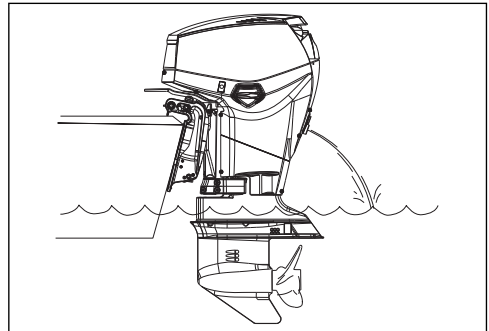

008469

ENGINE STOPPING

Twist the throttle grip to SLOWEST speed position.

Move shift lever to NEUTRAL.

Press the engine cut-off switch until the outboard stops running.

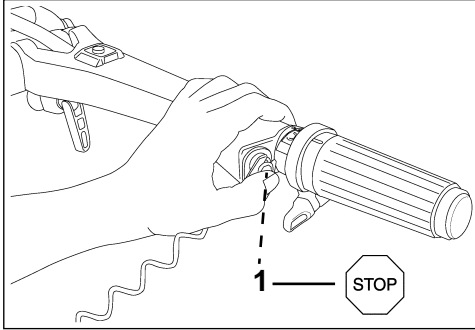

1. Engine cut-off switch

002413

Disconnecting the Fuel Hose

Disconnect the fuel hose to fuel connector.

⚠ WARNING

A small amount of fuel may be released when the fuel connector is disconnected. Always wipe off any fuel spillage.

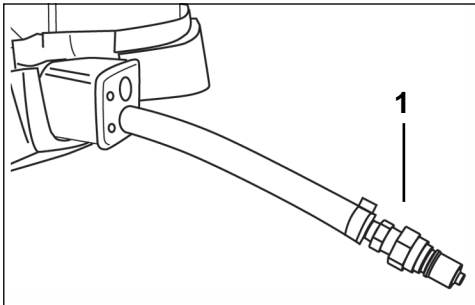

1. Fuel connector

002018M

If equipped, close vent screw on fuel tank cap.

SHIFTING AND SPEED CONTROL

NOTICE Carefully check the function of all control and engine systems before leaving the dock. DO NOT shift the engine into FORWARD or REVERSE while it is shut off.

Shifting

With engine running, twist the throttle grip to SHIFT or slower.

Move the shift lever with a firm, quick motion to FORWARD or REVERSE gear.

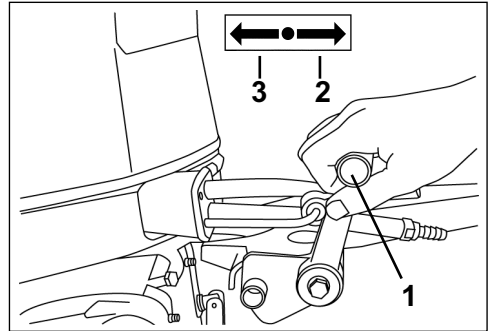

1. Shift lever
2. FORWARD
3. REVERSE

002415

⚠ WARNING

Do not operate the outboard in REVERSE with the tilt/run lever in the TILT position. The outboard may tilt out of the water, resulting in loss of control.

NOTICE When shifting from FORWARD to REVERSE or from REVERSE to FORWARD, pause at NEUTRAL until the engine is at idle speed and the boat has slowed.

Speed Control

With the outboard running, turn the Twist Grip throttle control on the steering handle to change engine speed.

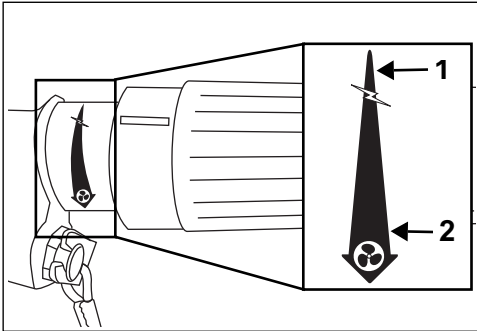

1. Decrease speed
2. Increase speed

007067

FUEL ECONOMY

Fuel economy can vary depending on boat load, hull design, and throttle setting. When boat reaches top speed, throttle back from FULL SPEED to a lower throttle setting. You will save fuel with a minimal loss of speed.

Throttle Friction

Adjust the throttle friction knob to reduce the effort required to hold a throttle setting.

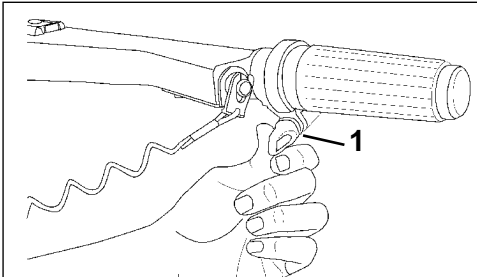

1. Throttle friction screw

002412

⚠ WARNING

Tighten knob only enough to hold throttle at a constant engine speed. Overtightening will prevent quick throttle changes in case of emergency.

ENGINE OVERHEATING

NOTICE Do not run your outboard without supplying water to it. Refer to **Short-Term Storage** on page 37. Water pump damage can occur in just a few seconds.

While boating, the outboard's water intakes must stay completely submerged and unobstructed. Observe proper transom height and tilt angle. While the outboard is running, the outboard's water pump indicator must discharge a steady stream of water. Check the indicator often, especially when operating in weeds, muddy and debris-laden water, and at extreme trim angles.

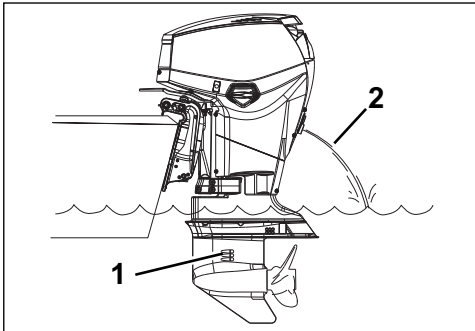

1. Water intake screens
2. Water pump indicator

008469

If the engine overheats:

- The *EMM* interrupts the ignition once per 50 engine revolutions to signal the operator.
- If the temperature becomes critical, engine speed is limited to 2500 RPM.

The protection system must be **RESET** before the engine will operate normally.

To **RESET** the system:

- The engine must be shut off and the correct operating temperature restored.

IF the overheat warning mode activates or the water pump indicator stream becomes intermittent or stops, stop the engine and:

- Clean the intake screens of any blockage.
- Clean the water pump indicator of any blockage.
- Restart the engine and run at idle.

IF cleaning the screens and indicator *does not* restore the indicator stream, return to harbor as soon as possible.

TILTING AND TRIM

TILTING

IMPORTANT: Use the tilt grip to tilt the outboard. Do not use the tiller handle as a lever.

Tilt UP

Move tilt/run lever to TILT position.

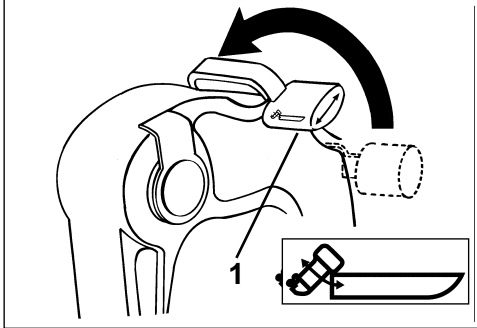

1. TILT position

DR3774

Grasp tilt strap or tilt grip on engine cover and tilt outboard to the full tilt position.

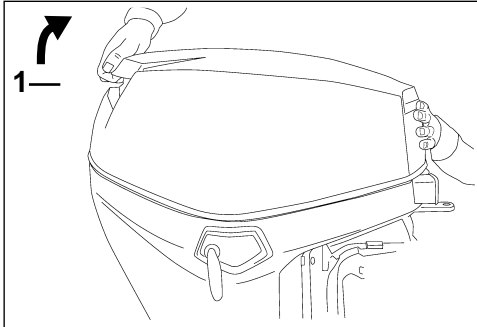

1. Tilt grip

002016

The tilt support will automatically engage.

⚠ WARNING

While outboard is tilted, leave tilt lever in the TILT position. When the tilt/run lever is in the RUN position, tilt support can release unexpectedly and allow outboard to drop, creating a risk of serious personal injury or loss of control.

Tilt DOWN

Move tilt/run lever to RUN position.

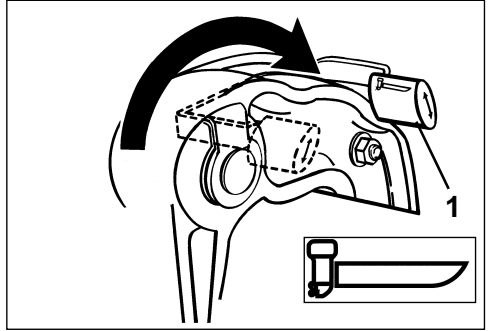

1. RUN position

DR3772

Grasp tilt grip on engine cover and raise outboard slightly.

Tilt support will automatically disengage.

Slowly lower outboard to its normal operating position.

NOTICE Operate outboard in normal operating position with tilt/run lever in the RUN position.

Tilt Support

Engage

Raise the outboard to full TILT position. Push tilt support bracket to "lock" position.

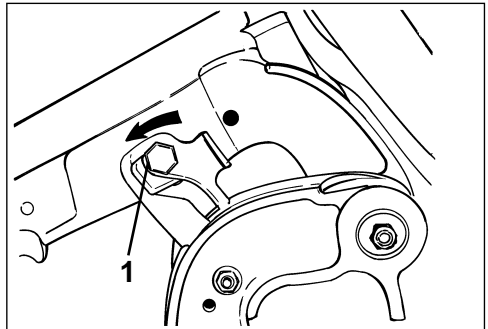

1. Tilt support bracket – lock position

DR3937

Disengage

Move tilt/run lever to RUN position. Tilt outboard fully and pull tilt support bracket to “unlock” position. Lower outboard.

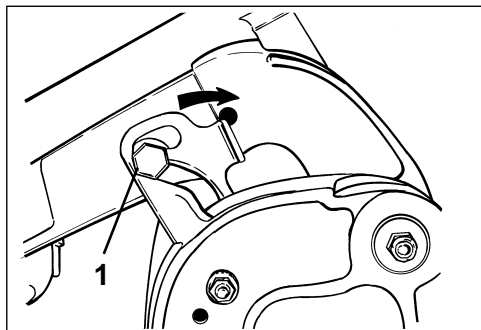

1. Tilt support bracket – unlock position DR3938

If tilt pin is positioned too LOW the front of boat will be DOWN and push water.

If tilt pin is positioned too HIGH the front of boat will be UP and bounce.

▲ WARNING

Boat stability and steering torque can vary due to changing water conditions. If any adverse conditions occur, reduce throttle and/or adjust tilt angle to maintain control. If you experience boat instability and/or high steering torque, the outboard must be serviced to correct these conditions.

If the bow of the boat plows the water at high speeds, the boat may bow steer or spin suddenly, possibly ejecting or otherwise seriously injuring occupants.

TRIM ANGLE ADJUSTMENT

The outboard should be perpendicular to the water when the boat is under way at full speed. This adjustment can only be determined by water testing the boat. Set angle adjustment for best performance with your normal load.

The boat should accelerate quickly, plane easily, and run parallel to the surface of the water at high speeds.

Place the outboard in full TILT position. Refer to **Tilt Support** on page 22.

- Turn the angle adjusting rod handle up. Push in against spring so retainer will release, then slide rod assembly all the way out.
- Insert rod in desired position. Make sure rod passes through both stern brackets.
- Push in against spring and turn rod handle down. Make sure the retainer dropped into lock position.

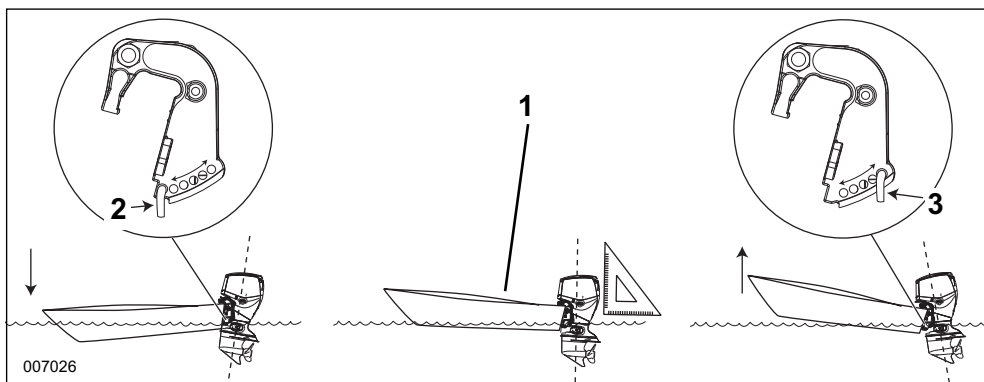

1. Parallel to the surface of the water
2. Tilt pin – LOW position
3. Tilt pin – HIGH position

IMPACT DAMAGE PROTECTION

Your outboard has a shock absorption system designed to help withstand damage from impact with underwater objects at low to moderate speeds.

High speed impacts with rigid underwater objects like pilings or boulders can be beyond the capability of the absorption system.

Such impacts can result in serious damage to your outboard and injury to boat occupants from the outboard or its parts entering the boat. Occupants can also be ejected or injured by falling against portions of the boat as a result of rapid deceleration following impacts.

When boating in unfamiliar, shallow, or debris-laden waters, seek information on safe boating areas and navigation hazards from a reliable local source.

Reduce your speed and keep a sharp lookout!

IMPORTANT: Impact damage is NOT covered by the outboard warranty.

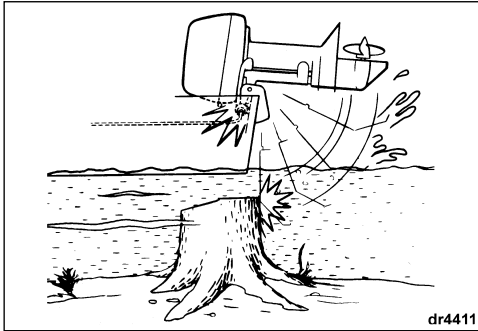

DR4411

NOTICE The outboard's shock absorption system does not work while operating in reverse. If you back into an object, either in the water or while trailering, your boat and outboard can be seriously damaged.

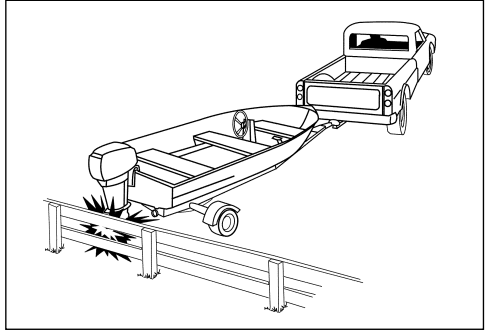

DR4412

If you hit any object:

- STOP immediately and examine the outboard for loosening of attaching hardware.
- INSPECT for damage to swivel and stern brackets, and steering components.
- EXAMINE the boat for structural damage.
- TIGHTEN any loosened hardware.

If the collision occurred in the water, proceed slowly to harbor. Before boating again, thoroughly inspect all components.

⚠ WARNING

Failure to inspect for damage after an accident or striking an object could result in sudden, unexpected component failure, loss of boat control, and personal injury. Unrepaired damage could reduce your boat and outboard's ability to resist future impacts.

TRANSPORTING THE OUTBOARD

WARNING

If engine is equipped with a quick-disconnect fuel hose, you **MUST** disconnect the fuel hose from the engine and the fuel tank to prevent fuel leaks:

- Whenever the engine is **NOT** being used
- Whenever the engine is being trailered
- Whenever the engine is in storage

NOTE: A small amount of fuel may be released when the fuel connector is disconnected.

Store portable fuel tanks in well-ventilated areas, away from heat sources and open flames. Close the vent screw of the fuel tank cap, if equipped, to prevent escape of fuel or fuel vapors which could accidentally ignite. Do not allow disconnected fuel hoses to leak fuel.

TRAILERING

Trailer your boat with the outboard in a vertical position. If your trailer does not provide adequate road clearance, support the outboard with an accessory trailering bracket.

NOTICE The outboard must be restrained when trailering. Bouncing during transport may damage the outboard and the boat's transom.

NOTICE Use of the tilt support bracket or tilt lock lever when trailering may cause damage to the outboard.

TRANSPORTING / STORAGE

If the outboard is laid down for transportation or storage, the oiling system must be primed before reusing the outboard. Refer to **Priming the Oil System** on page 15.

SPECIAL OPERATING CONDITIONS

COLD AND FREEZING WEATHER

NOTICE When operating in conditions under 32°F (0°C), *Evinrude/Johnson XD100* oil, must be used.

During operation in freezing weather, keep the gearcase submerged at all times.

Upon removing your outboard from the water, leave it in a vertical position until its cooling system is drained. Store the outboard vertically.

If the outboard's gearcase is equipped with an integral speedometer pickup, all water must be cleared from the hose to prevent gearcase damage. Refer to **Transporting / Storage** on page 25.

NOTICE Water remaining in the gearcase, cooling system or other components can freeze, causing serious engine damage.

HIGH ALTITUDE

The outboard's *EMM* will automatically compensate for changes in altitude. However, if you boat above 3000 ft. (900 m), you will experience a slight loss of power due to reduced air density.

If the engine drops below the recommended RPM operating range at full throttle, select a lower pitch propeller.

If you return to sea level, install the original propeller and verify correct RPM operating range.

SALT WATER

Upon removal from salt water, leave outboard in a vertical position until its cooling system has drained. During long periods of mooring, tilt the gearcase out of the water, except in freezing temperatures. Flush the outboard, if desired. Refer to **Short-Term Storage** on page 37.

Salt Water Lubrication Points

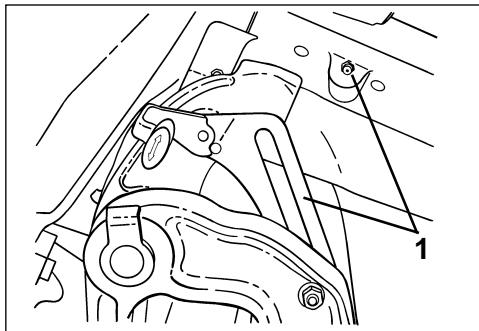

1. Tilt lever, tilt lever shaft, and swivel bracket lubrication points (annually) DR6687

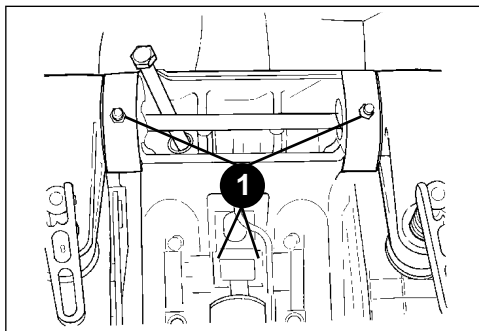

1. Tilt tube lubrication points (annually) DR31473

SHALLOW WATER

Gearcase damage can occur if the gearcase is allowed to drag on the waterway bottom. Use caution when operating in shallow water.

IMPORTANT: Impact damage is NOT covered by the outboard warranty.

TOWING

Should you require a tow from another boat:

- Shift the engine to NEUTRAL;
- Tilt its gearcase out of the water;
- Move all persons into another boat; and
- Keep speed slower than planing speed.

WEEDY WATER

Weeds block water intakes and may cause your outboard to overheat. Weeds on the propeller create vibration and reduce boat speed.

When operating in weedy water, run at slow speeds and in REVERSE frequently to clear weeds from the propeller and water intakes. Check the water pump indicator often.

If REVERSE operation does not clear away weeds, SHUT OFF the engine. Remove weeds from propeller area and water intakes before operating at higher speed.

SUBMERSION AND RECOVERY

The *MFE* outboard is NOT a submersible engine. However, due to the extreme operating conditions this engine may experience, a crankcase drain system has been provided to allow the engine to be de-watered should submersion occur during deployment or accidental rollover.

This system allows the operator to quickly remove water and re-start the engine in an emergency situation. In most cases the engine can be returned to normal operation without damage.

Submersion of the outboard should be avoided if possible. Damage could occur to the engine wiring harness and water could contaminate the oiling system. Extended submersion, particularly in salt water, could result in corrosion of internal components such as piston rings, cylinder sleeves, and bearings.

Once an outboard has been submerged in fresh or salt water, it must be serviced and started within three (3) hours of recovery. Immediate service can minimize the corrosive effect that air has on the polished surfaces of the crankshaft, connecting rods, and internal powerhead bearings.

IMPORTANT: If the outboard cannot be started or serviced immediately, it should be re-submerged in fresh water to avoid exposure to the atmosphere.

DE-WATER PROCEDURE

- 1) Place shift lever in NEUTRAL and remove the engine cut-off switch clip and tether cord.
- 2) Twist throttle grip to **slowest** speed position.

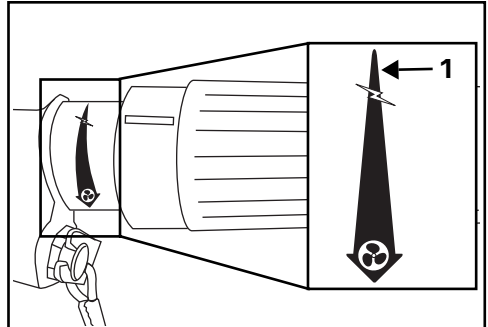

1. Slowest speed position

007067

- 3) Turn the drain valves forward to the DRAIN position.



007840

- 4) Tilt outboard to the full tilt position and turn so the drain valves are on the lowest side.

⚠ CAUTION To avoid outboard falling during de-water procedure, tilt/run lever **MUST** remain in the TILT position.

- 5) Pull starter handle slowly until starter engages. Continue pulling with firm pressure to force water out of the engine.

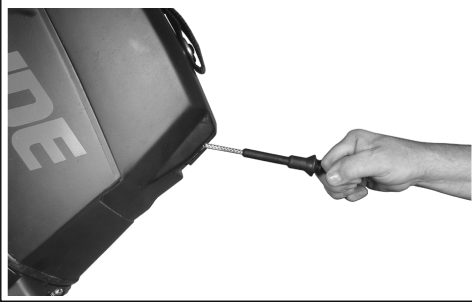

005049

- 6) When the engine begins to turn freely, pull an additional 8-20 times. This will help drain water that might be trapped in the cylinders.
- 7) Tilt outboard to the normal running position.
- 8) Replace engine cut-off switch clip and tether cord.
- 9) Squeeze primer bulb several times until definite resistance is felt.
- 10) With twist grip in the slowest position, pull starter handle to start engine.
- 11) After engine has run at IDLE speed for 30-60 seconds, turn drain valves to the RUN position.

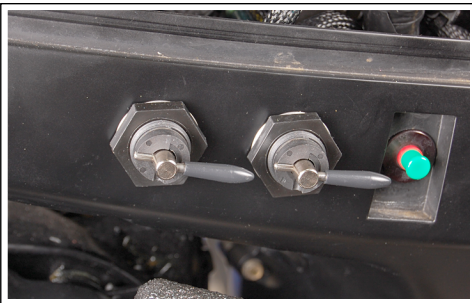

007841

NOTICE DO NOT run the outboard with the drain valves in the DRAIN position more than 3 minutes. Engine damage can result.

- 12) Continue to run under normal operating conditions (boat on plane) for at least 30 minutes (2500 RPM or above).

IMPORTANT: You MUST run the outboard after the de-water procedure to dry out internal moisture.

- 13) Stop engine and run the **Winterizing Procedure** on p. 38.

POST-SUBMERSION SERVICING

When an outboard has been submersed, it MUST be serviced before storage.

If the outboard has been in salt water:

- Run the engine for approximately five minutes in fresh water at full operating temperature. Refer to **Short-Term Storage** on p. 37.
- Spray the entire engine with fresh water to remove salt deposits.

After five submersions, the flywheel must be removed and the valley between the crankshaft and the stator windings must be cleaned.

PROLONGED SUBMERSION

Prolonged submersion, or submersion at depths beyond several feet may cause engine damage.

If prolonged submersion occurs, even if the engine can be started, the engine must be disassembled and cleaned.

DO NOT attempt to start the outboard if sand or silt may have entered the engine. Disassemble and clean.



Maintenance

ENGINE EMISSIONS INFORMATION

Maintenance, replacement, or repair of the emission control devices and systems may be performed by any marine SI (spark ignition) engine repair establishments or individual.

Manufacturer's Responsibility

Beginning with 1999 model year outboards, manufacturers of marine engines must determine the exhaust emission levels for each engine horsepower family and certify these outboards with the United States of America Environmental Protection Agency (EPA). An emissions control information label, showing emission levels and engine specifications, must be placed on each outboard at the time of manufacture.

Dealer's Responsibility

When performing service on all 1999 and more recent *Evinrude* outboards that carry an emissions control information label, adjustments must be kept within published factory specifications.

Replacement or repair of any emission related component must be executed in a manner that maintains emission levels within the prescribed certification standards.

Dealers are not to modify the outboard in any manner that would alter the horsepower or allow emission levels to exceed their predetermined factory specifications.

Exceptions include manufacturer's prescribed changes, such as altitude adjustments, for example.

Owner Responsibility

The owner/operator is required to have engine maintenance performed to maintain emission levels within prescribed certification standards.

The owner/operator is not to, and should not allow anyone to, modify the engine in any manner that would alter the horsepower or allow emissions levels to exceed their predetermined factory specifications.

Tampering with the fuel system to change horsepower or modify emission levels beyond factory settings or specifications will void the product warranty.

EPA Emission Regulations

All new 1999 and more recent *Evinrude* outboards manufactured by BRP are certified to the EPA as conforming to the requirements of the regulations for the control of air pollution from new watercraft marine spark ignition engines. This certification is contingent on certain adjustments being set to factory standards. For this reason, the factory procedure for servicing the product must be strictly followed and, whenever practicable, returned to the original intent of the design. The responsibilities listed above are general and in no way a complete listing of the rules and regulations pertaining to the EPA requirements on exhaust emissions for marine products. For more detailed information on this subject, you may contact the following locations:

VIA U.S. POSTAL SERVICE:

Office of Mobile Sources
Engine Programs and Compliance Division
Engine Compliance Programs
Group (6403J)
401 M St. NW
Washington, DC 20460

VIA EXPRESS or COURIER MAIL:

Office of Mobile Sources
Engine Programs and Compliance Division
Engine Compliance Programs
Group (6403J)
501 3rd St. NW
Washington, DC 20001

EPA INTERNET WEB SITE:

www.epa.gov

MAINTENANCE SCHEDULE

Routine inspection and maintenance is necessary to prolong outboard life. The following chart provides guidelines for inspection and maintenance.

IMPORTANT: Outboards used in high hour applications require more frequent inspections and maintenance. Adjust schedule for operating and environmental conditions.

Description		Every 100 Hours or Annually	Every 300 Hours or 3 Years ⁽¹⁾
Anti-corrosion anodes ⁽²⁾			✓
Electrical and ignition wires, inspect for wear or chafing			✓
Engine to transom mounting hardware, re-tighten (40 ft. lbs.)			
Fasteners, inspect any loosened components			✓
Fuel and oil system components, inspect and repair leaks			✓
Fuel filter, replace		✓	
Gearcase lubricant, replace ⁽¹⁾	A		✓
Grease fittings, lubricate ⁽²⁾	B		✓
Propeller shaft splines, inspect and lubricate ⁽²⁾	B		✓
Spark plugs, inspect and replace if necessary		✓	
De-carbon engine - required for "heavy fuel" use	C	✓	
Steering handle, inspect and lubricate	B		✓
Thermostats, inspect ⁽²⁾			✓
Throttle cable, inspect and adjust			✓
Water pump, inspect or replace if necessary			✓

(1) Average use. Heavy use, or use in salt or polluted water requires more frequent inspection and maintenance (annual checks are recommended).

(2) Annually in salt water applications – Refer to **Salt Water Lubrication Points** on page 26.

- A. *HPF Pro* Gearcase Lubricant
- B. *Triple-Guard* Grease
- C. *Evinrude/Johnson Engine Tuner*

SERVICE

ANTI-CORROSION ANODES

The outboard is equipped with one or more anodes that protect it from galvanic corrosion. Disintegration of the anode is normal and indicates it is working. Check each anode periodically. Replace anodes smaller than 2/3 their original size. Additional anodes may be required depending on engine application and environmental conditions. See your Dealer for replacement anodes.

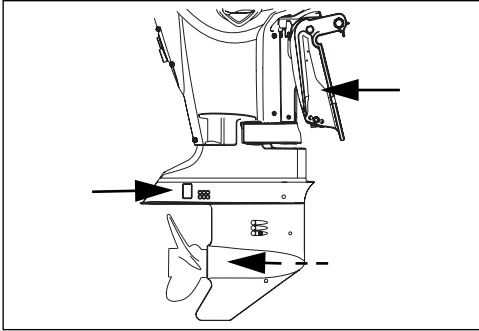

008486

Galvanic corrosion destroys underwater metal parts and can occur in fresh or salt water; however, salt, brackish, and polluted waters will accelerate corrosion.

Metal-based antifouling paint on the boat or outboard and the use of improperly installed shore power in the area of your moored boat will also accelerate corrosion.

NOTICE NEVER paint the anode, its fasteners, or its mounting surface. Painting will reduce its corrosion protection.

FLUSHING

The outboard can be flushed after each use on a trailer or at dockside while it is vertical. It is **not** necessary to run the engine.

NOTICE If you cannot store the outboard in the recommended vertical position, be sure the cooling system is drained completely. Never place the gearcase higher than the powerhead. Any water remaining in the exhaust passages can run into the cylinders and cause serious damage.

Using Lower Engine Cover Flushing Port

- 1) Place the outboard in an area with good drainage.
- 2) Connect garden hose to flushing port.
- 3) Turn on the water. Keep water pressure between 20 to 40 psi (140 to 275 kPa).

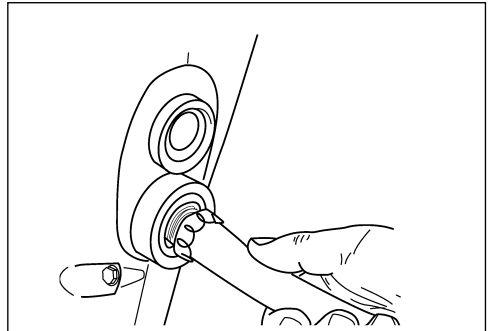

002024

- 4) Leave the outboard in vertical position long enough to completely drain the powerhead.

Using Gearcase Flushing Device

- 1) Place the outboard in an area with good drainage.
- 2) Remove propeller and place the shift lever in NEUTRAL position.
- 3) Connect garden hose to flushing device and install flushing device on gearcase.
- 4) Turn on the water. Keep the water pressure between 20 and 40 psi (140 to 300kPa).

- 5) Start the engine and RUN AT IDLE SPEED. Flush engine for at least five minutes. A steady stream of water must flow from exhaust relief port of outboard.

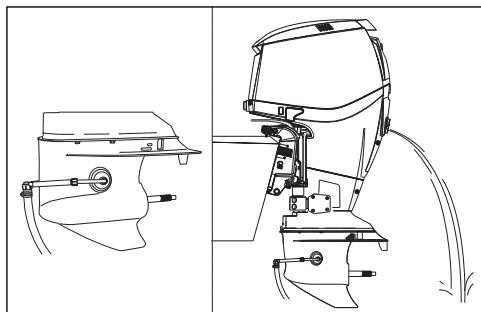

1. Flushing device
2. Stream of water

008499

- 7) Turn engine OFF. Leave the outboard in vertical position long enough to completely drain the powerhead.

DE-CARBONING PROCEDURE

This procedure is required every 100 hours or annually for MFE 55 outboards operated using heavy fuels, including JP5, JP8, Jet A, or kerosene.

If the outboard has been operated on an emergency fuel, such as diesel, the de-carbon procedure must be performed immediately after return from the mission.

For maximum benefit, the outboard should be run on unleaded gasoline during this procedure if possible.

Outboard should be on the boat and in the water. If outboard cannot be run in the water, make sure to supply adequate cooling water.

▲ DANGER

DO NOT run the engine indoors or without adequate ventilation or permit exhaust fumes to accumulate in confined areas. Engine exhaust contains carbon monoxide which, if inhaled, can cause serious brain damage or death.

▲ WARNING

To prevent injury from contact with rotating propeller; remove the propeller before de-carbon procedure (MRL).

NOTICE DO NOT run outboard without a water supply to the outboard's cooling system. Cooling system and/or powerhead damage could occur.

- 1) Remove air silencer.
- 2) Set the fuel selector switch to the gasoline position and run the outboard on gasoline during the de-carboning procedure.
- 3) Start and run outboard long enough to reach normal operating temperature.
- 4) Set engine speed to approximately 1500 RPM.
- 5) Spray the entire contents of a can of *Engine Tuner*, P/N 777185, into the throttle body. Do not let the engine stall until the can is empty.
- 6) STOP engine and allow Engine Tuner to soak in powerhead for a minimum of 8 hours to 16 hours maximum.

NOTICE DO NOT allow Engine Tuner to stay in powerhead for more than 16 hours. Extended exposure can damage internal engine parts.

- 7) Restart engine and run at 1500 RPM for 15 minutes.
- 8) Next, run outboard on boat, at high speed, for 30 to 60 minutes. Boat should be on plane and outboard should be running at least 2500 RPM.

If outboard will not run at high RPM, make sure that spark plugs are not fouled. Replace spark plugs if necessary. Refer to **Spark Plugs** on p. 36.

FUSE

The engine harness fuse does not affect normal operation of the outboard. However, a working fuse is required for communication with diagnostic software during test procedures.

On outboards equipped with an accessory electric starter, a blown fuse will not allow the starter to operate. Replace it with a fuse of the same rating. A spare fuse is provided.

Repeated fuse failures indicate a potentially serious problem. Do not replace it with higher rated fuse; the outboard must be serviced.

Fuse Replacement

NOTICE Use only fuses of the same rating. Your *Evinrude MFE* outboard uses 10-amp fuses.

Remove engine cover. Install spare fuse in place of failed fuse.

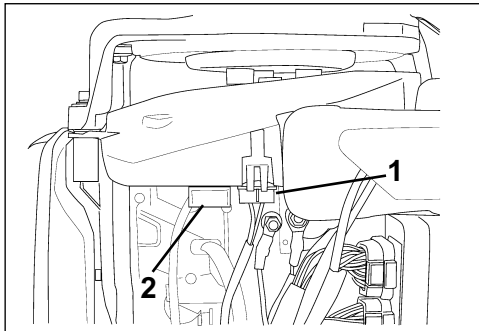

1. Fuse
2. Spare fuse

002401

SPARK PLUGS

⚠ WARNING

The ignition system presents a serious shock hazard. Use caution to avoid injury from shock or injury resulting from your reaction to shock. Do not handle primary or secondary ignition components while the engine is cranking or running.

Spark plugs should be serviced by qualified personnel. Incorrect spark plug maintenance can lead to engine damage.

IMPORTANT: Replacement spark plugs MUST be installed following the indexing procedure in the service manual.

Marine Engine Duty Cycles

The International Council of Marine Industry Associations (ICOMIA) Standard No. 36-88 specifies a marine engine duty cycle based on documented studies.

A duty cycle is a profile of engine running and usage. This duty cycle is used to determine average spark plug longevity and maintenance requirements for *Evinrude E-TEC* outboards.

ICOMIA Marine Engine Duty Cycle	
Engine Speed as Percentage of Rated Speed (RPM)	Time at Specified RPM (Percentage of total engine running time)
IDLE	40%
40%	25%
60%	15%
80%	14%
100%	6%

IMPORTANT: Some running profiles and conditions can lead to spark plug wear sooner than expected. Depending on your specific usage, the spark plug maintenance schedule may require adjustment.

STORAGE

⚠ DANGER

DO NOT run the engine indoors or without adequate ventilation or permit exhaust fumes to accumulate in confined areas. Engine exhaust contains carbon monoxide which, if inhaled, can cause serious brain damage or death.

You must protect against natural environmental conditions that can be damaging to an outboard. The warranty does not cover engine failure caused by these conditions.

NOTICE Temperature and humidity changes during storage period can cause corrosion of internal engine components.

Winterization prepares the outboard for long-term off-season storage. During winterization, extra oil is used to coat internal engine components. Refer to **Long-Term Storage (Winterization)** on page 38.

Stabilize the fuel supply (gasoline). Fuel remaining in the fuel tank can oxidize, resulting in loss of octane and fuel system deposits.

Use *Evinrude/Johnson 2+4 Fuel Conditioner* to prevent gum and varnish deposits from forming in fuel system components. Refer to **Fuel Additives (gasoline only)** on page 13.

⚠ WARNING

Prevent injury from moving engine components. Before starting the outboard:

- Shift it to **NEUTRAL**.
- Keep hands, clothes, and hair clear of powerhead.
- Remove the propeller.

⚠ WARNING

If engine is equipped with a quick-disconnect fuel hose, you **MUST** disconnect the fuel hose from the engine and the fuel tank to prevent fuel leaks:

- When the engine is **NOT** being used
- When the engine is being trailed
- When the engine is in storage

A small amount of fuel may be released when the fuel connector is disconnected.

Store fuel tanks in well-ventilated areas, away from heat sources and open flames.

Prevent escape of fuel or fuel vapors which could accidentally ignite.

Close the vent screw of the fuel tank cap (if equipped).

Do not allow disconnected fuel hoses to leak fuel.

If the outboard is laid down for transportation or storage, the oiling system must be primed before reusing the outboard. Refer to **Priming the Oil System** on page 15.

SHORT-TERM STORAGE

Between uses, store your outboard in a vertical position to allow the cooling system to drain completely.

LONG-TERM STORAGE (WINTERIZATION)

⚠ WARNING

Outboard must be in **NEUTRAL** before performing winterization. Starting outboard in gear can cause personal injury. If winterizing on a trailer, the propeller must be removed before performing procedure. Failure to remove propeller can cause personal injury or death.

Winterization prepares your outboard for long-term off-season storage. During winterization, the engine is “fogged” and extra oil is used to coat internal engine components.

Winterization requires a specific process of steps.

Preparation

Your outboard can be winterized in the water. **If winterizing in water**, make sure the water intake screens are completely submerged.

- 1) If using gasoline, stabilize the engine’s fuel supply. Add 2+4 *Fuel Conditioner* following instructions on container. Fill fuel tank.
- 2) **If winterizing on a trailer**, remove the propeller. Attach a garden hose to flushing port and turn on the water. Refer to **Short-Term Storage** on page 37.
- 3) Outboard **must** be in **NEUTRAL**, and shift linkage must be in **NEUTRAL** position at all times during winterization procedure.

Winterizing Procedure

- 1) Fully advance the throttle grip. Start the outboard. Outboard runs at slow idle speed.

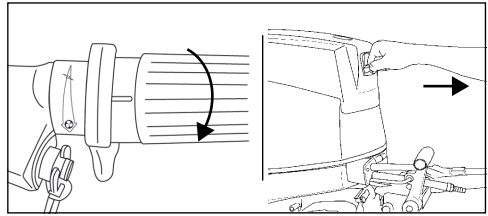

Tiller Control – Typical

007874
005416

- 2) After outboard runs for at least 15 seconds, move throttle grip to **IDLE** position. Outboard continues to run at slow idle speed.

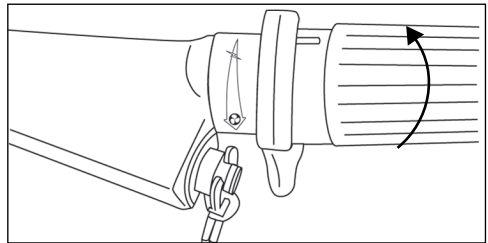

007873

- 3) After outboard runs for another 15 seconds, fully advance the throttle grip again. Outboard will accelerate to fast idle speed and fog itself.
- 4) Allow outboard to run until it shuts itself **OFF** automatically (one to two minutes).

Winterization is complete when outboard shuts itself off.

- **If the outboard DOES NOT shut itself off**, you may not have properly advanced throttle grip.
- **If the engine exceeds 3000 RPM**, the outboard may have been shifted into gear.

In either event, immediately press **ENGINE** cut-off switch to turn outboard **OFF** and restart the procedure.

After Winterization

- 1) After the outboard shuts itself off, remove engine cut-off switch clip / key switch. Do not start the outboard again after winterization is completed.
- 2) **If winterizing on a trailer**, turn off water and detach garden hose. Grease propeller shaft splines with recommended lubricant, and re-install propeller.

IMPORTANT: When winterizing is finished, leave the outboard in vertical position long enough to completely drain the powerhead.

- 3) Top off oil tank.

Extra engine oil is used during the winterization procedure. Some excess oil may appear on the skeg below the gearcase area. **This is normal.**

Avoid potential oil stains by placing a shop towel or suitable container under the propeller and skeg for the duration of the storage.

PRE-SEASON CHECK

Remove your outboard from storage and prepare it for a season of reliable service by performing a general check and a few preventive maintenance procedures.

Examine all loosened or removed hardware. Replace damaged or missing parts with *Evinrude/Johnson Genuine Parts* or equivalent. Check the gearcase for leakage. If leakage is evident, the gearcase seals should be replaced.

IMPORTANT: Gearcase lubricant is **thick and clear**. Do not confuse this with engine oil, which may normally appear on the skeg after performing the long-term (winterization) storage procedure.

Anticorrosion anodes — Check condition. Refer to **Special Operating Conditions** on page 26.

NOTICE **DO NOT run your outboard—even for a brief start-up—without supplying water to it. Water pump damage can occur in just a few seconds.**

Following **Engine Starting** on page 16, start the outboard. If the outboard was winterized, it may smoke briefly on the first start of the season. Let it idle while you:

Observe running quality. If poor, refer to **Troubleshooting** on page 40.

Confirm water pump operation. Water must flow from the water pump indicator in a steady stream. If it does not, shut off the outboard and investigate. Refer to **Transporting the Outboard** on page 25.

Stop the outboard and check the fuel system for leaks.

WARNING

Failure to check for fuel leakage could allow a leak to go undetected, resulting in fire or explosion.

TROUBLESHOOTING

SYMPTOM	POSSIBLE CAUSE
Starter motor will not operate (If electric start kit installed)	<ul style="list-style-type: none"> • Shift handle not in NEUTRAL. • Fuse blown.
Engine will not start	<ul style="list-style-type: none"> • Shift handle not in NEUTRAL. • Engine cut-off switch clip not in place. • Not following starting instructions. Refer to Engine Starting on page 16. • Fuel tank empty. • Fuel hose kinked. • Fuel system contaminated with water or dirt. • Fuel system not primed after running out of fuel. Refer to Fuel System Priming on page 14. • Fuel filter obstructed. • Throttle not at IDLE. Return throttle to IDLE. • Spark plugs incorrect. Refer to Spark Plugs on page 36. • Spark plugs improperly gapped, carboned, burned, or wet.
Engine will not idle properly	<ul style="list-style-type: none"> • Debris on propeller. • Spark plugs damaged or incorrect. Refer to Spark Plugs on page 36. • Fuel system contaminated with water or dirt.
Engine loses power	<ul style="list-style-type: none"> • Spark plugs damaged or incorrect. Refer to Spark Plugs on page 36. • The fuel selector switch may be in the wrong position. • Warning system may be activated. Check temperature and oil level. • Fuel filter obstructed. • Fuel system contaminated with water or dirt. • Water intakes obstructed and cooling system not operating correctly. Refer to Transporting the Outboard on page 25. • Oiling system malfunction. • Protection mode activated. Refer to Transporting the Outboard on page 25.
Engine runs, but makes little or no progress	<ul style="list-style-type: none"> • Propeller hub loose, slipping. • Propeller blades bent or missing. • Propeller shaft bent. • Propeller debris.
Warning system activates	<ul style="list-style-type: none"> • Refer to Transporting the Outboard on page 25.

Product Information

INSTALLATION

⚠ WARNING

The outboard must not exceed the maximum horsepower indicated on the boat's capacity plate. Such overpowering can cause loss of control. Contact the boat's manufacturer if your boat lacks a capacity plate.

Boats designed for remote-steered outboards might be overpowered by a tiller-steered outboard of the maximum rated horsepower. Refer to the boat manufacturer if you are unsure.

Incorrectly matched boat and outboard transom heights can cause boat instability and loss of control. Refer to Transom Height.

Prevent lateral movement and possible outboard loss by using the mounting hardware supplied or hardware of sufficient size, strength, and quality. Refer to Installing the Outboard on page 43.

A mounting surface that is damaged or too thin to support your outboard while underway might fail during operation, causing a loss of control. Be sure the boat's transom or mounting bracket is structurally sound and between 1 5/8 in. (41 mm) and 2 3/4 in. (70 mm) in thickness.

NOTICE Use an appropriate hoist to lift the engine. Refer to Specifications on page 48 for engine weight.

TRANSOM HEIGHT

Make sure the transom height matches the length of the outboard to be installed.

- A 19 to 21 in. (48.3 to 53.3 cm) transom height uses a 20 in. (50.8 cm) shaft outboard.
- The shaft length of the outboard being installed should match the transom height of the boat.
- Refer to **Specifications** on page 48 for transom height.

Determine transom height by measuring from the top edge of the transom, along the centerline.

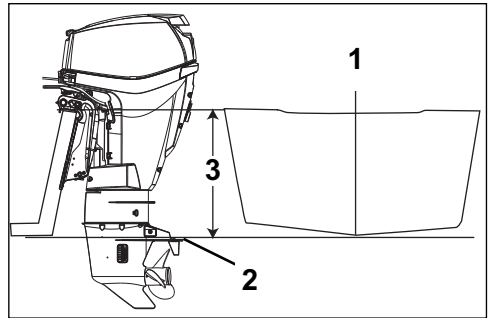

1. Centerline
2. Antiventilation plate
3. Transom Height

007039

Boat performance depends on outboard mounting height.

Generally, the anti-ventilation plate of the gearcase should align with the bottom of the hull.

Test outboard and boat performance at different heights until the best performance is achieved.

IMPORTANT: Be sure that outboard water pressure is not adversely affected by the mounting height of the outboard.

INSTALLING THE OUTBOARD

⚠ WARNING

The outboard must be correctly installed. Failure to correctly install the outboard could result in serious injury, death or property damage.

IMPORTANT: The outboard warranty will not cover product damage or failure that results from incorrect outboard installation.

⚠ WARNING

Even if equipped with clamp screws, the outboard must be bolted to the boat to prevent it from “working off the transom” during operation.

Use Transom Mounting Kit, P/N 394219, to prevent loss of outboard. The kit includes a transom mounting plate and hardware for fastening outboard to transom.

Center the outboard on the transom (or mounting bracket) and tighten clamp screws by hand.

Use the outboard stern brackets as a template for location and size of holes to drill in the transom.

Use each stern bracket’s mounting holes as a guide to drill four 11/32 in. (8.7 mm) holes through the transom.

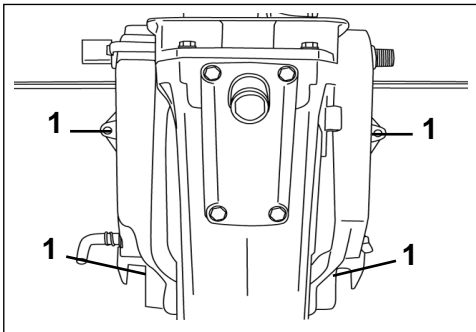

1. Drilled transom holes

002215

Install the mounting bolts through the stern brackets and transom. Install round backing plates and locknuts onto bolts and tighten securely.

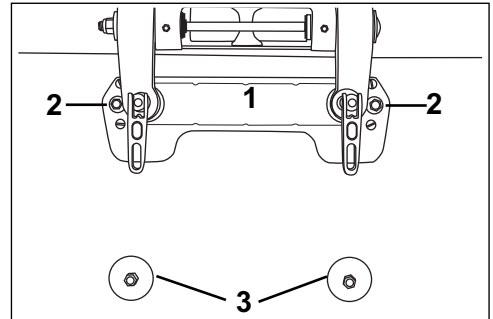

1. Transom plate
2. Small washers
3. Large washers

18961

The kit also includes clamp pads, which must be used to secure mounting bolts in slots at the bottom of the outboard stern brackets.

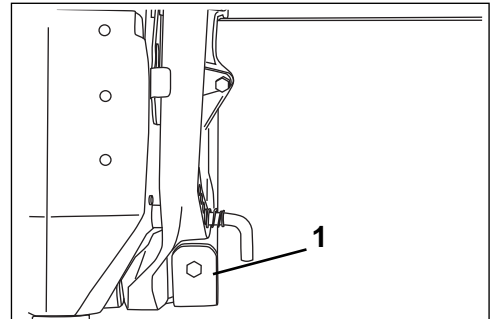

1. Clamp pad

COB2505

⚠ WARNING

When replacing bolts, screws, or other fasteners, use *Evinrude/Johnson* parts or parts of equivalent strength and material.

PROPELLER – MRL MODELS

Propeller Selection

⚠ WARNING

Be alert of people in the water. Always shift the outboard to **NEUTRAL** and shut off the engine immediately when your boat is in an area where there might be people in the water. Serious injury or death can result from contacting a rotating propeller or moving boat and outboard.

To select the correct propeller for your boating application, your boat and outboard **MUST** be water tested.

IMPORTANT: The correct propeller for your boat, under normal load conditions, will allow the engine to run near the midpoint of the RPM operating range at full throttle. Refer to **Specifications** on page 48.

⚠ WARNING

When servicing the propeller, always shift the outboard to **NEUTRAL** position, turn the key switch **OFF**, and twist and remove all spark plug wires so the outboard cannot be started accidentally.

IMPORTANT: Apply *Triple-Guard* grease to the entire propeller shaft before installing the propeller. At least annually, remove the propeller and check for debris. Clean the shaft and regrease it before reinstalling a propeller.

Installation

Slide thrust washer onto shaft with shoulder facing aft.

Slide propeller onto shaft, engaging the splines and seating it on the thrust bushing.

Slide spacer onto the shaft and engage the propeller shaft splines.

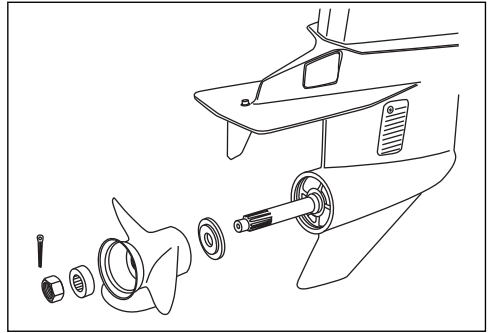

007055

Wedge a block of wood between the propeller blade and the anti-ventilation plate.

Install propeller nut and tighten to a torque of 120-144 in. lbs. (13.6-16.3 N·m).

Install keeper on propeller nut, align keeper slots and cotter pin hole.

IMPORTANT: If cotter pin holes in the propeller nut and propeller shaft are not aligned, tighten the nut until they are in line. Do not loosen.

Install new cotter pin and bend ends to secure.

Remove block of wood. Make sure engine is in **NEUTRAL**; give propeller a spin. It must turn freely.

Repair

If your propeller hits a solid object, the impact is partially absorbed by the rubber bushing in the hub to help prevent damage to the outboard. A strong impact can damage the hub and propeller blades. Damage to blades can cause unusual and excessive vibration. Damage to the hub can cause excessive engine RPM with little forward movement.

IMPORTANT: Avoid or limit operation using a damaged propeller. Carry a spare propeller.

Keep your propeller in good condition. Use a file to smooth slight damage to blade edges.

IMPELLER – MJRL MODELS

Removal

Use a 3/16 Ballhex driver to remove the six impeller housing screws. Remove the impeller housing.

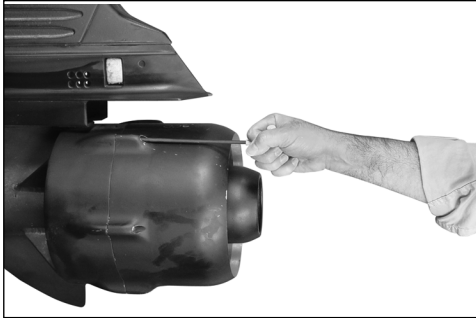

006650

Remove the cotter pin and loosen the impeller nut. Remove the nut, spacer, impeller, and thrust bushing.

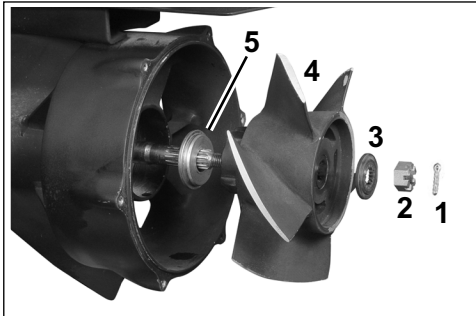

006638

1. Cotter pin
2. Impeller nut
3. Spacer
4. Impeller
5. Thrust bushing

Installation

Apply a small amount of *Triple-Guard* grease to the impeller shaft splines. Place the thrust bushing in the impeller and then slide the assembly onto the impeller shaft.

Install the spacer on splines of the impeller shaft. Install and torque the impeller nut 120 to 140 in. lbs. (14 to 16 N·m).

If cotter pin holes in the impeller nut and impeller shaft are not aligned, continue to tighten the nut until they are in line. Do not loosen.

Insert a new cotter pin through the impeller nut and shaft. Bend its ends over the nut to secure the assembly.

Install the impeller housing, and following sequence shown, tighten screws in stages to a torque of 70 to 100 in. lbs. (8 to 12 N·m).

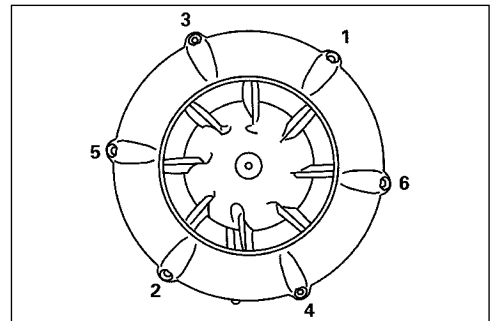

DRC7178

TILLER HANDLE ATTACHMENT

The tiller handle can be removed without tools to minimize required storage space.

To attach tiller handle to the outboard:

- Place shift rod through shift lever.

- Install washer and retaining clip on shift rod.

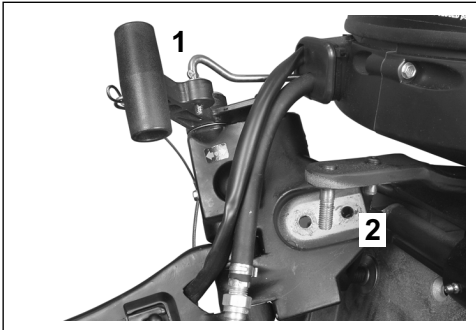

1. Shift rod
2. Steering arm studs

006500



1. Retaining clip

006502

- Place tiller handle bracket on steering arm studs and secure with hand nut.

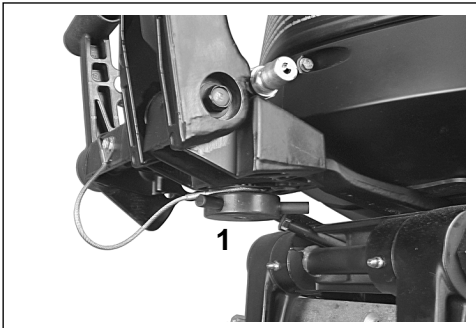

1. Hand nut

006501

ADJUSTMENTS

IDLE RPM IN GEAR

The idle RPM in gear setting can be adjusted, if desired, to provide more idle control, steering, and quietness in certain applications.

IMPORTANT: The *Evinrude Diagnostics* software program is required to adjust the idle RPM setting.

STEERING FRICTION

Steering friction should be adjusted so that a slight drag is felt when turning the outboard with the steering handle. If adjustment is necessary, turn the adjustment screw:

- Clockwise to increase friction; or
- Counterclockwise to decrease friction.

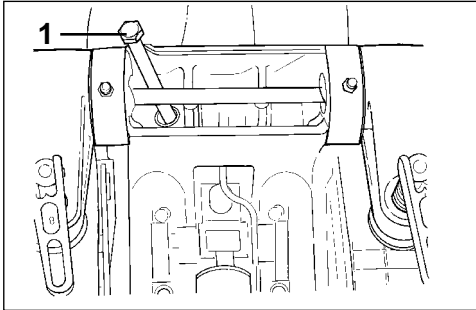

1. Steering friction screw

DR31473

⚠ WARNING

DO NOT overtighten for “hands-off” steering. Reduced steering control could result.

TRIM TAB (PROPELLER MODELS)

⚠ WARNING

Improper trim tab adjustment can cause difficult steering.

A propeller will generate steering torque when the propeller shaft is not running parallel to the water's surface. The trim tab is adjustable to compensate for this steering torque.

IMPORTANT: A single trim tab adjustment will relieve steering effort under only one set of speed, outboard angle and load conditions. No single adjustment can relieve steering effort under all speed, outboard angle and load conditions. If the boat pulls to the left or right when its load is evenly distributed, adjust the trim tab as follows:

With the outboard shut OFF, loosen the trim tab screw. If the boat pulled to the right, move the rear of the trim tab slightly to the right. If the boat pulled to the left, move the rear of the trim tab slightly to the left.

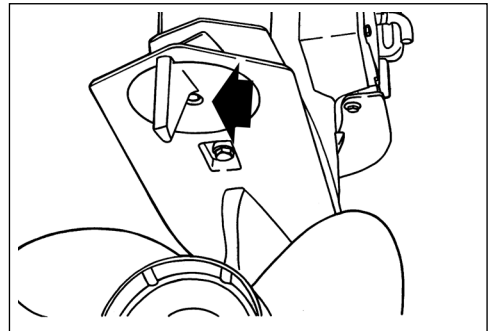

DR5158

Tighten the trim tab screw to a torque of 35-40 ft. lbs. (47-54 N·m). Test the boat and, if needed, repeat the procedure until steering effort is as equal as possible.

High outboard installations — The trim tab might be above the water when the outboard is trimmed out. Steering effort might increase. Steering effort will be reduced if you trim the outboard in and submerge the trim tab.

SPECIFICATIONS

55 MFE Models	
Displacement	52.7 cu. in. (864 cc)
Engine Type	In-line, 2 Cylinder, Two-Cycle, <i>Evinrude E-TEC</i>
Full Throttle Operating Range	5500 to 6000 RPM
Power ⁽¹⁾	55 HP (41 kw) @ 5750 RPM
Idle RPM in Gear	750 ± 50
Ignition Timing	<i>EMM</i> Controlled
Fuel Requirements	Heavy Fuels— JP5, JP8, Jet A, Kerosene Gasoline—87 Pump Posted AKI (90 RON) – Refer to Fuel Requirements on page 13
Oil – Lubricant – Capacity	<i>Evinrude/Johnson XD100</i> oil – Refer to Oil Requirements on page 15 2.0 qt. (1.9 l)
Spark Plug	Refer to Emissions Label on outboard
Fuses	P/N 967545 – Refer to Fuse on page 36
Fuel Filter	In-line Replaceable
Gearcase – Lubricant – Capacity	<i>Evinrude HPF Pro</i> 22 fl. oz. (650 ml)
Propeller	Refer to Propeller Selection on page 44
Weight	MRL – 250 lbs. (113 kg) MJRL – 270 lbs. (122 kg)
Sound at Driver's Ear (LpA) ICOMIA 39.94	76.8 dB(A) (MRL models)
Vibration at Tiller (arms)	Less than 2.5 m/s ²
Transom Height	19 1/2 to 20 in. (495 to 508 mm)

(1) Rated following the standards of ICOMIA 28.83, ISO 3046 and NMMA.

PRODUCT WARRANTY INFORMATION

BRP LIMITED WARRANTY FOR *EVINRUDE* MULTI FUEL ENGINES SOLD IN THE UNITED STATES AND CANADA (NOT FOR SALE IN CALIFORNIA)

1. SCOPE OF THE LIMITED WARRANTY

BRP US Inc.* (“BRP”) warrants its *Evinrude*® Multi Fuel Engines sold for recreational or commercial use in the United States (except California) and Canada (“Product”) from defects in material or workmanship for the period and under the conditions described below.

2. EXCLUSIONS — *The following are not warranted under any circumstances:*

- Replacement of parts due to normal wear and tear;
- Routine maintenance parts and services including but not limited to: maintenance requirements, lower unit oil changes, lubrication, linkage adjustments and replacement of fuses, zinc anodes, thermostats, starter motor bushings, trim motor brushes, filters, propellers, propeller bushings and spark plugs;
- Damage caused by improper or lack of installation, maintenance, winterization and/or storage, failure to follow the procedures and recommendations in the Operator’s Guide;
- Damage resulting from removal of parts, improper repairs, service, maintenance, or modification, or use of parts or accessories not manufactured or approved by BRP, which in its reasonable judgment, are either incompatible with Product or adversely affect its operation, performance, or durability, or resulting from repairs done by a person that is not an authorized Dealer;
- Damage caused by abuse, misuse, abnormal use, neglect, racing, improper operation or operation of the Product in a manner inconsistent with the recommended operation described in the Operator’s Guide;
- Damage resulting from external damage, accident, submersion, water ingestion, fire, theft, vandalism or any act of God;
- **Operation without proper fuel, oil or lubrication, or with fuels, oils or lubricants which are not suitable for use with the Product (see the Operator’s Guide);**
- Damage resulting from rust or corrosion;
- Damage caused from cooling system blockage by foreign material;
- Damage resulting from sand or debris in the water pump;
- Damage resulting from sand or debris in the jet pump assembly;
- Cosmetic or paint changes due to exposure to the elements.

This warranty will be **voided in its entirety and rendered null and void** where:

- Product has been altered or modified in such a way so as to adversely affect its operation, performance or durability, or change its intended use, horsepower or emission levels; or
- Product is or has operated on improper fuels, oils, or lubricants for extended periods of time.
- Product is or has been used for racing at any point, even by a prior owner.

3. LIMITATIONS OF LIABILITY

ALL WARRANTIES, EXPRESSED OR IMPLIED, INCLUDING WITHOUT LIMITATION ANY WARRANTY OF MERCHANTABILITY OR FITNESS FOR A PARTICULAR PURPOSE ARE LIMITED IN DURATION TO THE LIFE OF THE EXPRESS LIMITED WARRANTY.

ALL INCIDENTAL, CONSEQUENTIAL, DIRECT, INDIRECT OR OTHER DAMAGES OF ANY KIND ARE EXCLUDED FROM COVERAGE UNDER THIS WARRANTY INCLUDING, BUT NOT LIMITED TO: expense for gasoline, expense for transporting Product to and from an authorized Dealer, removal of Product from a boat and reinstallation, mechanic’s travel time, in-and-out of water charges, slip or dock fees, trailering or towing, storage, telephone, cell phone, fax or telegram charges, rental of a like or replacement Product or boat during warranty services or down time, taxi, travel, lodging, loss of or damage to personal property, inconvenience, cost of insurance coverage, loan payments, loss of time, loss of income, revenue or profits, or loss of enjoyment or use of Product.

SOME STATES, PROVINCES, OR JURISDICTIONS DO NOT ALLOW FOR THE DISCLAIMERS, LIMITATIONS OF INCIDENTAL OR CONSEQUENTIAL DAMAGES, OR OTHER EXCLUSIONS IDENTIFIED ABOVE. AS A RESULT, THEY MAY NOT APPLY TO YOU. THIS WARRANTY GIVES YOU SPECIFIC RIGHTS, AND YOU MAY ALSO HAVE OTHER LEGAL RIGHTS WHICH MAY VARY FROM STATE TO STATE, OR PROVINCE TO PROVINCE.

No distributor, authorized Dealer or any other person is authorized to make any affirmation, representation or warranty regarding Product other than those contained in this limited warranty and, if made, shall not be enforceable against BRP. BRP reserves the right to modify this warranty at any time, being understood that such modification will not alter the warranty conditions applicable to the Products sold while this warranty is in effect.

4. WARRANTY COVERAGE PERIOD

This limited warranty will be in effect from the date of delivery to the first retail consumer or the date the Product is first put to use, whichever occurs first, for a period of TWELVE (12) CONSECUTIVE MONTHS.

Except that exhaust emission-related components are warranted for sixty (60) consecutive months or one hundred seventy five (175) hours of engine use, whichever occurs first; and evaporative emission related components are warranted for twenty-four (24) consecutive months. *Please see your Authorized Evinrude Outboard Engine Dealer for emission-related service.*

The repair or replacement of parts or the performance of service to Product under this warranty does not extend the life of this limited warranty beyond its original expiration date. All *Evinrude/Johnson® Genuine Parts* and accessories installed by an authorized dealer at the time of sale bear the standard BRP parts and accessories one-year limited warranty.

5. CONDITIONS TO HAVE WARRANTY COVERAGE

This warranty coverage is available only on *Evinrude* Multi Fuel Engines purchased as new and unused from a dealer authorized to distribute *Evinrude* products in the country in which the sale occurred ("Dealer"), and then only after the BRP specified pre-delivery inspection process has been completed and documented by the purchaser and Dealer. Warranty coverage only becomes available upon proper registration of Product by Dealer or owner.

Only the original purchaser and any subsequent owners who reside in the United States and Canada and have purchased Product from BRP or an authorized U.S. or Canadian Dealer are eligible for warranty registration and warranty coverage hereunder. Such limitations are necessary in order to allow BRP to protect the safety of its products, its consumers, and the general public.

As outlined in the Operator's Guide, timely routine required maintenance must be performed to maintain warranty coverage. BRP may require proof of proper maintenance prior to authorizing warranty coverage.

6. WHAT TO DO TO OBTAIN WARRANTY COVERAGE

The registered owner must notify an authorized Dealer within two (2) days of the appearance of a defect. The potentially defective Product must not be used until it has been inspected by an Authorized Service Point. BRP is not responsible for damages caused by the use of a Product after the appearance of a defect. Owner must bring Product, including any defective part therein, to Dealer promptly after the appearance of the defect, and in any event, within the warranty period, and must provide Dealer with reasonable opportunity to repair the defect. The expenses of transporting Product to and from Dealer for warranty service are to be borne by the owner.

If the Product has not previously been registered, the owner may also be required to present proof of purchase to Dealer for warranty repairs. Owner is required to sign the repair/work order prior to the start of the repair in order to validate the warranty repair.

All parts replaced under this warranty become the property of BRP.

7. WHAT BRP WILL DO

BRP's obligations under this warranty are limited to, at its sole discretion, repairing or replacing parts of Product found to be defective in material or workmanship, in the reasonable judgment of BRP. Such repair or replacement of parts will be done without charge for parts and labor, at any authorized Dealer. BRP's responsibility is limited to making the required repairs or replacements of parts with new or BRP-certified re-manufactured parts. No claim of breach of warranty shall be cause for cancellation or rescission of the sale of Product to owner.

In the event that warranty service is required outside of the fifty United States or Canada, owner will bear responsibility for any additional charges due to local practices and conditions, such as, but not limited to, freight, insurance, taxes, license fees, import duties, and any and all other financial charges, including those levied by governments, states, territories and their respective agencies.

BRP reserves the right to improve, modify or change Products from time to time without assuming any obligation to modify Products previously manufactured.

8. TRANSFER

If the ownership of Product is transferred during the warranty coverage period, this warranty shall be transferred and be valid for the remaining coverage period provided that the former or new owner promptly contacts BRP or Dealer and gives the name and address of the new owner.

9. CONSUMER ASSISTANCE

In the event of a controversy or dispute in connection with this BRP limited warranty, BRP recommends that you first try to resolve the issue at the dealership level by discussing the issue with Dealer's service manager or owner;

If further assistance is required, please contact BRP US Inc. / Outboard Engines Division, After Sales Support, P.O. Box 597, Sturtevant, WI 53177, 1-262-884-5993.

* In Canada, products are distributed and serviced by Bombardier Recreational Products Inc.

© Registered trademark of Bombardier Recreational Products Inc. or its affiliates.

© 2011 BRP US Inc. All rights reserved. Limited Warranty MFE - March 2011

**BOMBARDIER RECREATIONAL PRODUCTS LIMITED WARRANTY
FOR *EVINRUDE* MULTI FUEL ENGINES
SOLD OUTSIDE THE UNITED STATES AND CANADA**

For a copy of the Limited Warranty, see your Bombardier Recreational Products (“BRP”) distributor/dealer authorized to distribute *Evinrude* products in the country in which the sale occurs.

If further assistance is required, please contact BRP US Inc. / Outboard Engines Division, After Sales Support, P.O. Box 597, Sturtevant, WI 53177, or the affiliate of BRP where the Product was registered for warranty.



CHANGE OF ADDRESS / CHANGE OF OWNERSHIP

If your address has changed or if there has been a change of ownership, be sure to fill out and mail the form provided on this page.

This notification is necessary for your own safety even after expiration of the original warranty, since BRP will be in a position to contact you if correction to your outboard is required. Outside the U.S. and Canada, this card should be sent to the Bombardier Recreational Products division where the outboard was registered. Please contact your Dealer or Distributor.



Change of Address

Change of Ownership

Model number

Serial Number

Old Address / Previous Owner

Last name

First name M.I.

Address

City State

Zip code Country

Phone number

Signature _____ Date _____

New Address / New Owner

Type of Use Recreational Commercial Government

Last name

First name M.I.

Address

City State

Zip code Country

Phone number

Signature _____ Date _____

Dealer Information

Dealer name

Dealer number

Phone number

Contact name

In the U.S. or Canada, mail completed form to: BRP US Inc. / Outboard Engines Division
After Sales Support
P.O. Box 597
Sturtevant, WI 53177



CONFIRMATION OF RECEIPT

Your Dealer

Name:	_____

Address:	_____

Upon delivery of your new *Evinrude/Johnson* outboard, complete and sign the form below. Your Dealer will take receipt of the form for their records.



Receipt

Name:	_____

Address:	_____

Owner of Model No:	_____
Serial No:	_____
	(To be completed by customer or selling Dealer)
<p>The Dealer named on this document has instructed me on the operation, maintenance, safety features and warranty policy, all of which I understand and agree to be bound with. I am also satisfied with the predelivery set-up and inspection of my <i>Evinrude/Johnson</i> outboard. I have also received a copy of the Operator's Guide.</p>	
Signature:	_____
Date:	_____





