

User's Guide

ICON II Single Binnacle Control



Original

EVINRUDE®
E-TEC®



TABLE OF CONTENTS

DECLARATION OF CONFORMITY	2
SINGLE LEVER BINNACLE MOUNT REMOTE CONTROL ...	4
GEAR POSITION LEDS.....	4
TURNING THE SYSTEM ON	5
STARTING AND STOPPING - MAIN STATION	6
STARTING AND STOPPING - SECOND STATION	6
SHIFT AND THROTTLE	7
TRIM & TILT	8
RPM TUNE	9
STATION TRANSFER	10
STATION PROTECT	11
NEUTRAL WARM UP MODE	12
LED BRIGHTNESS AND SYSTEM DISPLAY BACKLIGHTING	13
CONTROL LEVER FRICTION	14
WINTERIZATION	15
FAULT DETECTION	16
PRODUCT WARRANTY	17

DECLARATION OF CONFORMITY

- Application of Council Directives:

Directive 94/25/EC as amended by 2003/44/EC – Recreational-Craft

This product has been designed to be compliant with the above Directive.

Maximum performance, and compliance with the EMC Directive, can only be ensured by correct installation. It is strongly recommended that the installation conforms with the following standards:

Applicable Standards

- ISO 8846 Small Craft-Electrical Devices

Protection against ignition of surrounding flammable gases.

ISO = International Standards Organization

This device meets or exceeds the applicable ABYC, ISO, and USCG safe boating rules, regulations, standards, and guidelines.

SAFE BOATING ON THE WEB

U.S. Coast Guard (US)	www.uscg.mil
U.S. Power Squadron (US)	www.usps.org
National Safe Boating Council (US)	www.safeboatingcouncil.org/
Canadian Coast Guard (CA)	www.ccg-gcc.gc.ca
The Royal National Lifeboat Institution (UK)	www.rnli.org.uk
The Boat Safety Scheme (UK)	www.boatsafetyscheme.com
Safe Boating Australia (AU)	www.safeboating.org.au
NSW Maritime (AU)	www.maritime.nsw.gov.au
Marine Safety Victoria (AU)	www.marinesafety.vic.gov.au
Maritime Safety Queensland (AU)	www.msq.qld.gov.au/
Transport South Australia (AU)	www.transport.sa.gov.au/
Recreational Boating Safety (AU)	www.dpi.wa.gov.au/imarine/19078.asp

Safety Information

This User's Guide may contain the following safety messages:

DANGER

Indicates a hazardous situation which, if not avoided, will result in death or serious injury.

WARNING

Indicates a hazardous situation which, if not avoided, could result in death or serious injury

CAUTION

Indicates a hazardous situation which, if not avoided, could result in minor or moderate personal injury.

NOTICE

Indicates an instruction which, if not followed, could severely damage engine components or other property.

This User's Guide contains information to prevent personal injury and damage to equipment. Use this guide in combination with the boat and outboard operator's guides. Always follow safety and operation information.

Be careful! Human error is caused by many factors: carelessness, fatigue, overload, pre-occupation, unfamiliarity of operator with the product, drugs and alcohol to name a few. Damage to your boat and outboard can be fixed in a short period of time, but injury or death, has a lasting effect.

WARNING

This product may contain lead, a chemical known to the State of California to cause cancer, birth defects, and other reproductive harm.

SINGLE LEVER BINNACLE MOUNT REMOTE CONTROL

Use this control for single outboard installations (single and dual stations).

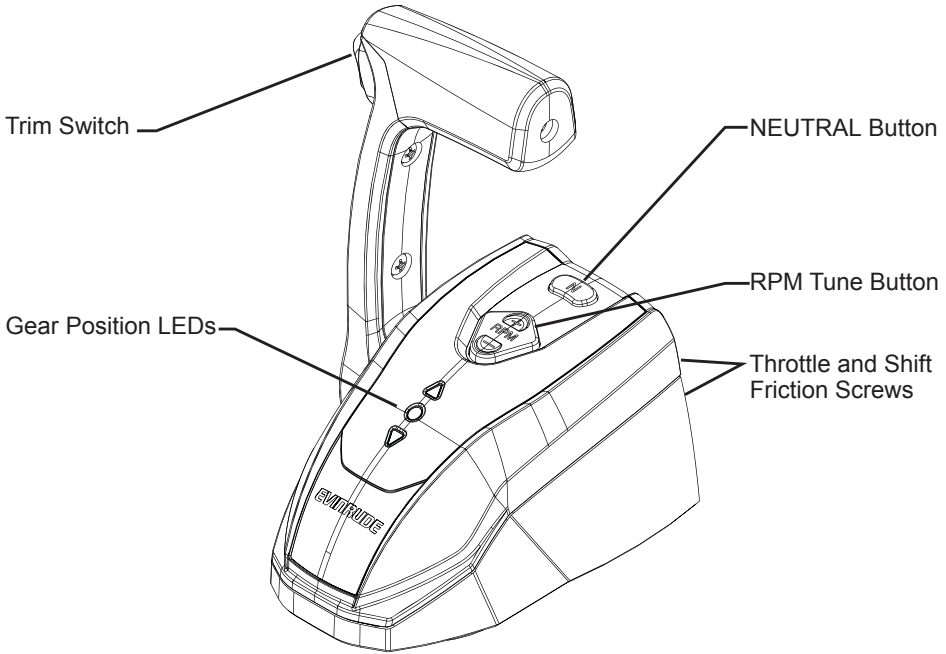

GEAR POSITION LEDs



The gear position LEDs are used to provide information to the operator. Regardless of the operating condition the LEDs follow control lever position, not actual gear position.



LEDs flashing five times per second indicate critical faults.

The brightness of the LEDs will not change when battery voltage fluctuates.

TURNING THE SYSTEM ON

1) Connect the emergency stop lanyard(s) to:

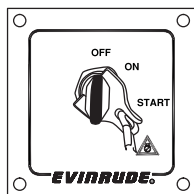

The key switch

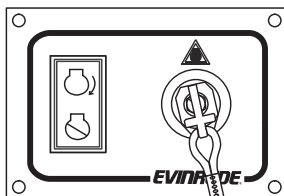

A second station emergency stop
(if equipped)

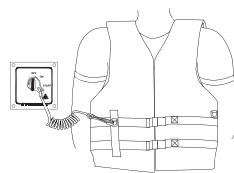

Your personal
flotation device

⚠ WARNING

Emergency stop lanyard **MUST** be securely attached to the operator, and clip **MUST** be installed to its switch. **DO NOT** operate outboard with clip removed from switch, except in an emergency.

Avoid knocking or pulling clip off the stop switch during normal boating. Avoid bumping the key if operating without the clip on the switch. The resulting unexpected loss of FORWARD motion can throw occupants FORWARD causing injury. Keep the lanyard free from obstructions and entanglements.

At each outing, test the system's operation. With the outboard running, remove clip from the switch by pulling the lanyard. If the outboard does not stop running, see your dealer.

In an emergency situation the outboard(s) cannot be restarted without the clip of the emergency stop lanyard in place at the second station.

2) Move the control lever to the NEUTRAL detent and turn the main station key switch to ON.

3) The NEUTRAL gear LED will illuminate.

Troubleshooting Tip: If the system does not turn ON:

- be sure all safety lanyards are connected at all stations
- check the 3A fuse on the public network power supply cable
- check the 10A fuse on the private network power supply cable

If a NEUTRAL LED is flashing five times per second, a critical fault is present and must be cleared.

STARTING AND STOPPING - MAIN STATION

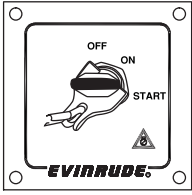

STARTING: Turn the key to START.

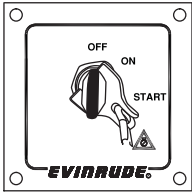

STOPPING: Turn the key to OFF.

STARTING AND STOPPING - SECOND STATION

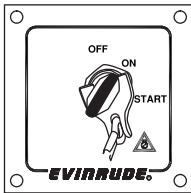

Turn the main station key to ON.

At the second station:

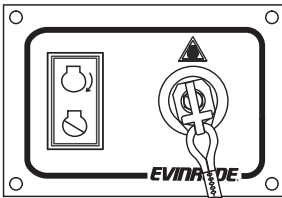

Press  to start.

Press  to stop.

Troubleshooting Tip: If the outboard does not start or stop, be sure the key switch cable is plugged in to the remote control wiring harness.

If equipped with a second station, be sure the lanyard is connected to the emergency stop switch and the switch cable is plugged in to the remote control wiring harness.

SHIFT AND THROTTLE

⚠ WARNING

When shifting from FORWARD to REVERSE or from REVERSE to FORWARD, pause at NEUTRAL until the engine is at idle speed and the boat has slowed.

Do NOT shift while the outboard is OFF.

Shift

Shift only when running at speeds below 1500 RPM.

Move the lever to the gear detent positions to shift the outboard.

Throttle

Move the lever past the gear detent positions to increase RPM in the selected gear.

During normal operation, the Engine Management Module (EMM) of the outboard limits speed to 1200 RPM while in NEUTRAL.

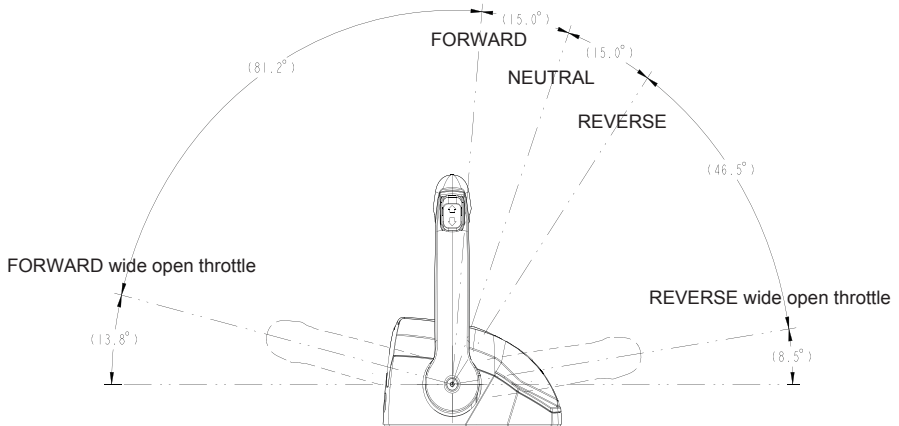

Troubleshooting Tip: If the outboard does not shift when the lever is moved to the detent position a critical fault may be present.

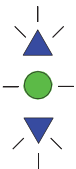

If the gear LEDs are flashing five times per second a critical fault is present and must be cleared.

TRIM & TILT

Press the trim switch on the lever to trim/tilt the outboard up or down. The switch will function when the system is ON or OFF.

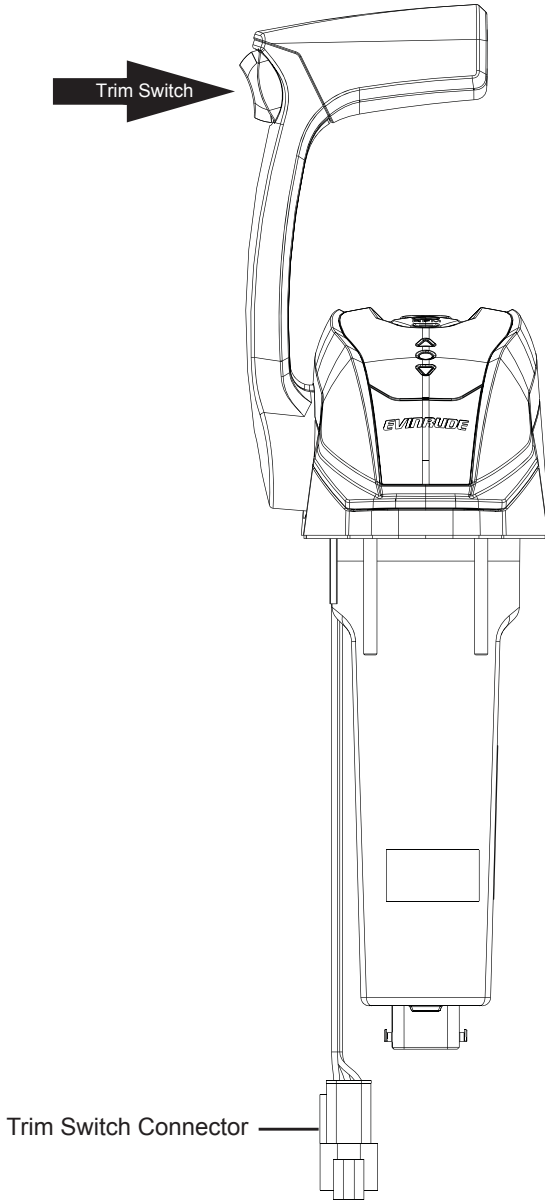

Troubleshooting Tip: If the outboard does not trim/tilt, be sure the trim switch connector is plugged in to the remote control wiring harness.

RPM TUNE



Use this feature to adjust RPM when the outboard is running in FORWARD gear. It will operate when the system is in the Neutral Warm Up mode.

Activate RPM Tune

- 1) Move the lever to FORWARD gear detent.
- 2) Press the (+) side of the button to increase RPM.
- 3) Press the (-) side of the button to decrease RPM.

Troubleshooting Tip: If the RPM adjustment does not function, be sure the control lever is in the FORWARD gear detent.

Deactivate RPM Tune

Move the control lever 1% or more in any direction, or shift into NEUTRAL or REVERSE, to cancel the function. The commanded throttle value will immediately respond to the current lever position.

RPM Adjustment In FORWARD Above Idle Speed

RPM adjustment range is limited to 5% of the throttle setting while in FORWARD, and operating above idle speed.



Press  to change the throttle setting 1%.

If the plus 5% limit is reached, or if the throttle reaches 100%, pressing the (+) side does nothing. If the minus 5% limit is reached, or if the throttle reaches 0%, pressing the (-) side does nothing.

The adjustment range is approximately 100 to 200 RPM depending on outboard speed. Move the control lever in any direction, or shift to FORWARD or REVERSE to cancel the RPM adjustment setting.

RPM Adjustment In FORWARD At Idle Speed



Press  to increase or decrease idle speed by 50 RPM increments.

The maximum amount the RPM can change is 250.

STATION TRANSFER

Use this function to transfer shift and throttle control between stations.

⚠ WARNING

NEVER leave the active control station while the outboard is in **FORWARD** or **REVERSE** gear. A loss of boat control could result. Only use Station Transfer when the outboard is in **NEUTRAL**.

Activate Station Transfer

- 1) Turn the system ON and start the outboard. Shift to NEUTRAL.
- 2) Go to the inactive station and connect the lanyard to the your personal flotation device.
- 3) At the inactive station, shift to NEUTRAL.

- 4) Press the (+) side of the  to activate the station.

- 5) Control will be transferred to the new station.

- 6) The NEUTRAL LED will turn ON.

Troubleshooting Tip: If the levers are not in NEUTRAL at both stations the inactive station gear LEDs will flash five times per second.

If the originally active station does not receive the shift and throttle message from the newly active station within a period of one second, the originally active station resumes control.

Station Transfer with Station Protect ON

If the Station Protect option is turned ON at the active station, use the following sequence at the inactive station to transfer control:

- 1) Press the (+) side of the  two times.

- 2) Press  one time.

- 3) Press the (+) side of the  one time.

STATION PROTECT

Use this feature to limit the use of the Station Transfer function. The Station Transfer function will not activate when Station Protect is ON.

Turning Station Protect ON

Use *Evinrude Diagnostics* software to turn Station Protect ON - see your authorized dealer.

Turning Station Protect OFF

1) Shift to NEUTRAL at both stations.

2) Press the (+) side of the  two times.

3) Press  one time.

4) Press the (+) side of the  one time.

Station Protect will turn OFF.

Troubleshooting Tip: If Station Protect does not turn ON or OFF, be sure the levers are in NEUTRAL at both stations.

NEUTRAL WARM UP MODE

Use the  button to activate this feature. It will allow a running outboard to increase RPM without shifting into FORWARD or REVERSE.

Activate NEUTRAL Warm-Up

- 1) Shift to the NEUTRAL detent, press  one time.
- 2) Move the lever forward to increase RPM. FORWARD gear will not engage.

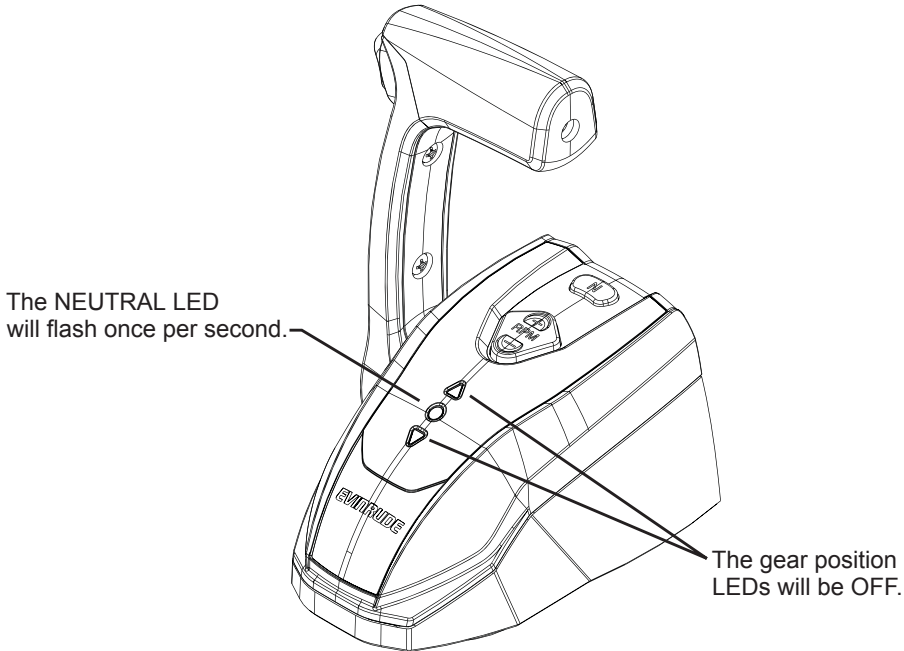

 **Troubleshooting Tip:** If the lever is not in the NEUTRAL detent when the mode is activated the NEUTRAL LED will flash five times per second.

Deactivate NEUTRAL Warm Up

Move the lever back to the NEUTRAL detent. Press  one time. The neutral warm up feature will turn OFF. The NEUTRAL LED will stop flashing and remain ON.

LED BRIGHTNESS AND SYSTEM DISPLAY BACKLIGHTING



Use the  on the remote control to adjust LED brightness and system display backlighting.

- 1) Turn the system ON and shift to NEUTRAL.
- 2) Press the (+) or (-) side of the button to increase or decrease the brightness of all LEDs and system displays in 10% increments.
- 3) Press the (+) side of the button one time after the maximum brightness is reached to reach the lowest intensity.
- 4) Press the (-) side of the button one time after the minimum brightness is reached to reach the highest intensity.

Each time the LED and system display brightness is changed, it is stored in the control and reloaded the next time the system is turned ON.

CONTROL LEVER FRICTION

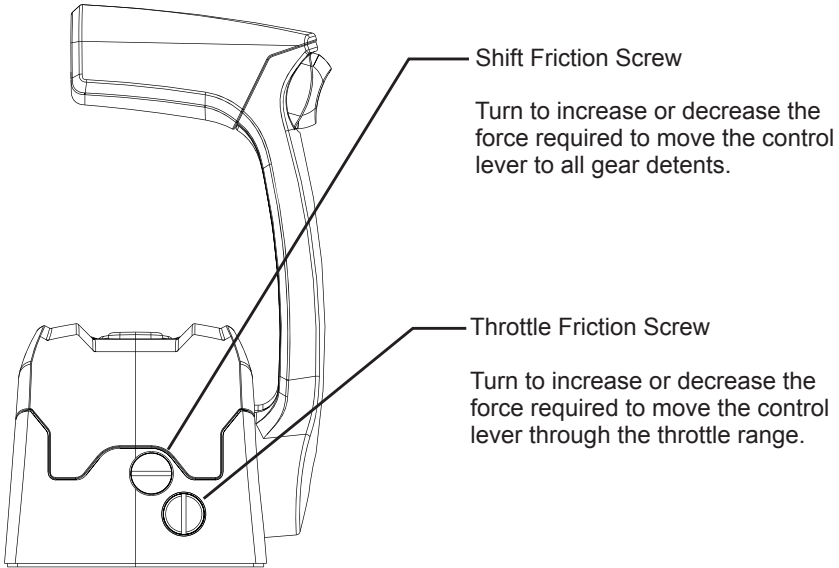

WINTERIZATION

Use this function to inject additional quantities of oil into the outboard for safe long term storage.

- 1) Turn the key switch to OFF.
- 2) Move the lever to the FORWARD wide open throttle position.

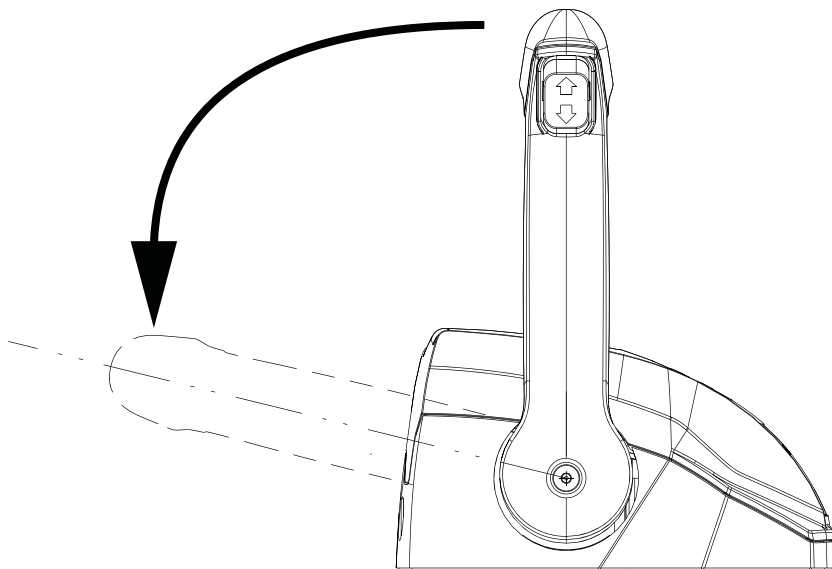



- 3) Turn the key switch to ON and wait a minimum of (3) seconds.
- 4) Attempt to start the outboard (3) times within three seconds (the starter will not engage or crank the outboard).
- 5) Move the lever to NEUTRAL and start the outboard.
- 6) Run the outboard at idle for a minimum of (3) seconds.
- 7) With the outboard running, attempt to start the engine (3) times within (3) seconds (the starter will not engage or crank the outboard).

The remote control will send the winterization message to the outboard using the public network. The outboard will automatically turn OFF when the process is complete.

After initiation of the winterization process, the remote control will ignore all throttle, gear, and control head switch operations. The control will still acknowledge Key OFF and/or Emergency Stop inputs.

Troubleshooting Tip: Be sure the throttle lever is all the way in the FORWARD wide open throttle position when starting winterization.

FAULT DETECTION

Type	Description	Response	Indication
Condition Code or Warning	<p>A conditional fault requiring remedial action to correct that does not affect normal operation.</p> <p>Example: Attempt to start outboard(s) with control lever(s) not in NEUTRAL.</p>	Response based on condition - upon resolution the system will resume full performance.	<p>Condition specific warning message shows on gauge or display.</p> 
Controllable	<p>Faults that allows for a fully controllable remedial action.</p> <p>Example: Low battery voltage.</p>	Informational only.	
Critical	<p>Faults that result in the inability to accurately determine critical outboard commands.</p> <p>Example: Communication between the control and outboard(s) <i>EMM(s)</i> is lost.</p>	Commanded lever and gear positions become unavailable. Outboards set to SAFE mode.	<p>Control LEDs flash</p>  <p>— ● — five times per second.</p> <p>Warning message shows on gauge or display.</p> 

A critical fault will prevent normal operation and result in the system entering a failed state. The control will:

- send “not available” data in the throttle and gear messages
- deactivate SYNC and NEUTRAL Throttle Warm-Up modes
- send the fault message and/or alarm and store the fault in memory
- flash the appropriate control head LED(s) five times per second

When the control detects that the outboard(s) are in NEUTRAL idle and the working lever(s) are in NEUTRAL, the system returns to normal operation.

PRODUCT WARRANTY

BRP US Inc.* ("BRP") warrants its *Evinrude®/Johnson®* Genuine Parts and accessories ("Product") sold by authorized *Evinrude* or *Johnson* dealers in the fifty United States and Canada from defects in material or workmanship for the period and under the conditions described below. This limited warranty does not apply to Products not bearing the *Evinrude* or *Johnson* trademarks that are made by other manufacturers. This limited warranty extends to the original retail purchaser only ("Purchaser") and is not transferable to any subsequent owner. This warranty is available only on Products purchased as new and unused from a dealer authorized to distribute the Products in the country in which the sale occurred ("Dealer").

Aluminum propellers, plastic propellers, stainless steel propellers, *Snap-In™* control cables and *DuraTank™* fuel tanks are warranted for THIRTY SIX (36) CONSECUTIVE MONTHS from the date of purchase as of July 1, 2006.

ICON™ engine control systems and components are warranted for THIRTY SIX (36) CONSECUTIVE MONTHS from the date of purchase for recreational use or TWELVE (12) CONSECUTIVE MONTHS for commercial use.

Powerhead assemblies are warranted for a period of SIX (6) CONSECUTIVE MONTHS from the date of purchase. All other Products are warranted for a period of TWELVE (12) CONSECUTIVE MONTHS from the date of purchase.

The following are not warranted under any circumstances: (a) normal wear and tear; (b) routine maintenance items including, but not limited to, adjustments, oil changes, water pumps, carburetor maintenance, spark plug replacements, etc.; (c) cosmetic damage or paint changes due to exposure to the elements; or (d) damage caused by: improper or lack of installation, maintenance, winterization and/or storage; failure to follow the procedures and recommendations in the Operator's Guide; removal of parts, improper repairs, service, maintenance, or modification; use of parts or accessories not manufactured or approved by BRP that are either incompatible with Product or adversely affect its operation, performance, or durability; repairs done by anyone, including Purchaser, other than an authorized Dealer; abuse, misuse, abnormal use, neglect, racing, improper operation or operation of Product in a manner inconsistent with the Operator's Guide; external damage, accident, submersion, water ingestion, fire, theft, vandalism or act of God; operation with fuels, oils or lubricants not suitable for use with Product (see Operator's Guide); rust or corrosion; or cooling system blockage by foreign material.

This warranty will be voided in its entirety and rendered null and void: (a) where Product has been altered or modified in such a way so as to adversely affect its operation, performance or durability, or has been altered or modified to change its intended use; or (b) where Product is or has been used for racing or any other competitive activity, at any point.

ALL WARRANTIES, EXPRESSED OR IMPLIED, INCLUDING WITHOUT LIMITATION ANY WARRANTY OF MERCHANTABILITY OR FITNESS FOR A PARTICULAR PURPOSE ARE LIMITED IN DURATION TO THE LIFE OF THIS EXPRESS LIMITED WARRANTY. ALL INCIDENTAL, CONSEQUENTIAL, DIRECT, INDIRECT OR OTHER DAMAGES OF ANY KIND ARE EXCLUDED FROM COVERAGE UNDER THIS WARRANTY INCLUDING, BUT NOT LIMITED TO: expense for gasoline, expense for transporting Product to and from Dealer, removal of Product from a boat and reinstallation, mechanic's travel time, in-and-out of water charges, slip or dock fees, trailering or towing, storage, telephone, cell phone, fax or telegram charges, rental of a like or replacement Product or boat during warranty services or down time, taxi, travel, lodging, loss of or damage to personal property, inconvenience, cost of insurance coverage, loan payments, loss of time, income, revenue, profits, enjoyment or use of Product.

SOME JURISDICTIONS DO NOT ALLOW FOR THE DISCLAIMERS, LIMITATIONS OF INCIDENTAL OR CONSEQUENTIAL DAMAGES, OR OTHER EXCLUSIONS IDENTIFIED ABOVE. AS A RESULT, THEY MAY NOT APPLY TO YOU. THIS WARRANTY GIVES YOU SPECIFIC RIGHTS, AND YOU MAY ALSO HAVE OTHER LEGAL RIGHTS THAT MAY VARY FROM JURISDICTION TO JURISDICTION.

Purchaser must bring the Product, including any defective part therein, and proof of purchase of the Product (original bill of sale) to Dealer promptly after the appearance of the defect and, in any event, within the warranty period. Purchaser must sign the repair/work order prior to repair to validate warranty coverage and must provide BRP/Dealer with a reasonable opportunity to repair/replace the defective part. All replaced parts become the property of BRP.

BRP's obligations under this warranty are limited to, at its sole discretion, repairing or replacing parts of Product found to be defective in material or workmanship, in BRP's reasonable judgment. Repair or replacement of parts will be without charge for parts and labor, at any authorized Dealer. No claim of breach of warranty shall be cause for cancellation or rescission of the sale of Product to Purchaser. BRP reserves the right to improve, modify or change Products without assuming any obligation to modify Products previously manufactured. If warranty service is required outside of the fifty United States or Canada, Purchaser will bear responsibility for any additional charges due to local practices and conditions including, but not limited to, freight, insurance, taxes, license fees, import duties, and any financial charges levied by governments, states, territories and agencies.

No distributor, Dealer or any other person is authorized to make any affirmation, representation or warranty regarding Product other than those contained in this limited warranty and, if made, shall not be enforceable against BRP. BRP reserves the right to modify this warranty at any time, being understood that such modification will not alter the warranty conditions applicable to the Products sold while this warranty is in effect. For assistance, please contact BRP US Inc. Consumer Support, P.O. Box 597, 10101 Science Drive, Sturtevant, WI 53177, 1-847-689-7090 or visit www.brp.com.

The Limited Warranty applies only to Products purchased as new and unused from a distributor or dealer authorized to distribute Products in the country in which the sale occurred.

Products purchased for commercial use, or used commercially at any time during the warranty period, are warranted for TWELVE (12) CONSECUTIVE MONTHS from the date of purchase. Product is used commercially when it is used in connection with any work or employment that generates income, during any part of the warranty period. Product is also used commercially when, at any point during the warranty period, it is installed on a boat that has commercial tags or is licensed for commercial use.

If warranty service is required outside of the country of original sale, Purchaser bears responsibility for any and all charges due to local practices and conditions that exceed or are in addition to customary charges in the country of sale, such as, but not limited to, freight, insurance, taxes, license fees, import duties, and any financial charges levied by governments, states, territories and agencies.

For assistance, please contact BRP US Inc. Consumer Support, P.O. Box 597, 10101 Science Drive, Sturtevant, WI 53177, 1-847-689-7090, or the affiliate of BRP Inc. where the Product was sold to the retail Purchaser.

No other change to the Limited Warranty shall be made or implied.

* In Canada, products are distributed and serviced by Bombardier Recreational Products Inc.

® Registered trademark of Bombardier Recreational Products Inc. or its affiliates.

© 2009 BRP US Inc. All rights reserved.

Effective as of July 1, 2009.

www.brp.com



SKI-DOO®
LYNX®

SEA-DOO®
EVINRUDE®

CAN-AM®
ROTAX®