



I-COMMAND™

User's Guide - 3.5 Inch Gauge

EVINRUDE | 
Johnson
GENUINE PARTS

IMPORTANT: This User's Guide outlines the functionality and usage of the *I-Command*[™] Integrated Performance System. Before using the *I-Command* Digital gauge, first read and understand ALL of the supplied product literature, as well as the boat's user's guide and outboard's operator's guide. This User's Guide should be stored onboard for reference.

The photographs, illustrations, and display screens used in this Guide might not depict actual models, figures, data fields, equipment, or software versions, but are intended as representative views for reference only. The continuing accuracy of this Guide cannot be guaranteed.

† *NMEA 2000* is a registered trademark of the National Marine Electronics Association or its subsidiaries.

The following trademarks are the property of Bombardier Recreational Products Inc. or its affiliates.

Evinrude[®] *E-TEC*[®]

I-Command[™]

Johnson[®]

ICON[™] Electronic Remote Control System

S.A.F.E.[™] (Speed Adjusting Failsafe Electronics)

BRP US Inc. / Outboard Engines Division

After Sales Support

P.O. Box 597

Sturtevant, WI 53177

Printed in the United States.

© 2010 BRP US Inc. All rights reserved.

TM, ® Trademarks and registered trademarks of Bombardier Recreational Products Inc. or its affiliates.

About This Guide

IMPORTANT: Read this User's Guide carefully before using the *I-Command* Digital gauge. This User's Guide should be kept onboard at all times during operation.

Need Assistance?

For any questions regarding the boat or outboard operation, please refer to the boat's user's guide, or outboard's operator's guide for support information.

For questions or problems regarding the *I-Command* Digital gauge, contact your dealer.

Dealers with questions should contact BRP Parts and Accessories Technical Help.

⚠ WARNING

For your safety and the safety of others, follow all safety warnings and recommendations supplied with the boat and outboard. Do not disregard any of the safety precautions and instructions.

IMPORTANT: This guide was written for 3.5 inch *I-Command* Digital gauges with software version 2.1.0. Gauges with other software versions may have features not documented in this guide. To view the software version, refer to "System Information" on page 100.

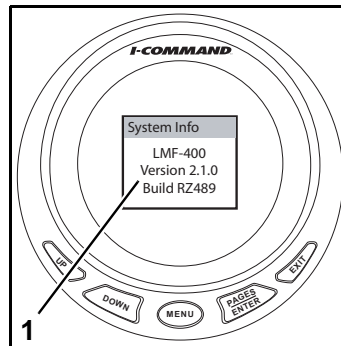

1. *I-Command* Digital gauge software version information

Table of Contents

Installation

Description	4
Instruments	5
Network Specifications	8
Network Setup	13

Setup and Operation

Power Up	16
Boat Setup	17
Engine Data	21
Information Displays	22
Screen Settings	24
Change Units	28

Customizing Displays

Fuel Manager	32
Add Page	34
Customizing Displays	40
Lock Pages	44
Accessing a Locked Page	46
Removing Pages	48
Page Scrolling	50
Pop-Ups	52

Advanced Operation

Configure Fluid Level Sensor	60
Fuel or Fluid Level Sensor Calibration	63
Fuel Management	66
Configure Sensors	72
Change Ranges	76
Winterize	78
Audio Settings	81
Reset Values	82
Sonar Alarms	84

Troubleshooting

Troubleshooting Steps	88
Engine Warnings	89
<i>Evinrude E-TEC</i> Engine Warnings	90
Network Troubleshooting Chart	92

Reference

Abbreviation Tables	96
Abbreviations Key	98
System Information	100

Product Warranty

Warranty Statement	102
--------------------------	-----

Installation

Description

The *I-Command™* Digital Integrated Performance System uses “plug and play” networking technology based on *NMEA 2000†* data communications standards (National Marine Electronics Association). These standards provide communications through a serial data network utilizing a Controller Area Network (CAN) integrated circuit (IC). This network operates at 250 kb/second and allows multiple electronic devices to be connected together on a common channel for easy information sharing. Multiple digital displays can be used to monitor and broadcast equipment and engine data.

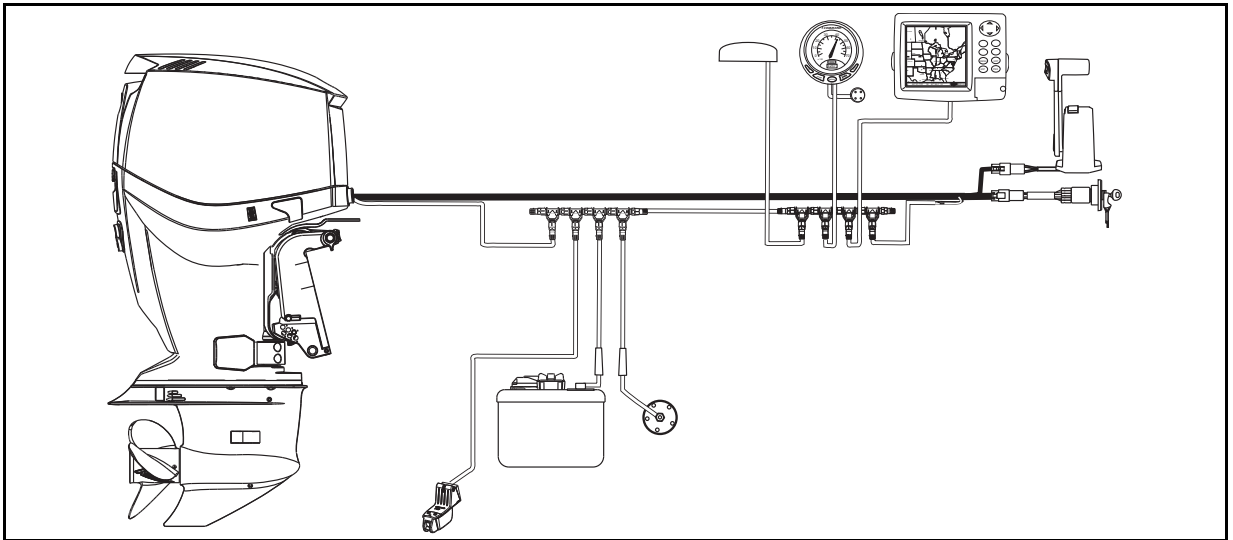

Instruments

Refer to the current *I-Command* Digital Network Guide for additional information and complete *I-Command* network installation instructions.

Spacing of Instruments

The minimum distances between instruments on a panel should be as follows:

- 3 13/16 (112 mm) center to center for 3 1/2 in. instruments
- 3 1/4 in. (95.5 mm) center to center for 3 1/2 in. instruments to 2 in. instruments
- 2 5/8 in. (77 mm) center to center for 2 in. instruments

Panel Thickness

Instruments can be mounted in panels up to 1 in. thick.

Hole Sizes

IMPORTANT: Check space behind panel to be sure adequate clearance for instruments exists before drilling panel.

3 1/2 in. Multifunction Gauge

Cut 3 3/8 in. (99 mm) diameter hole in panel for 3 1/2 in. instruments.

Fastening to Panel

Insert instrument into panel hole. Install bracket and tighten nuts finger tight.

Gauge Dimensions

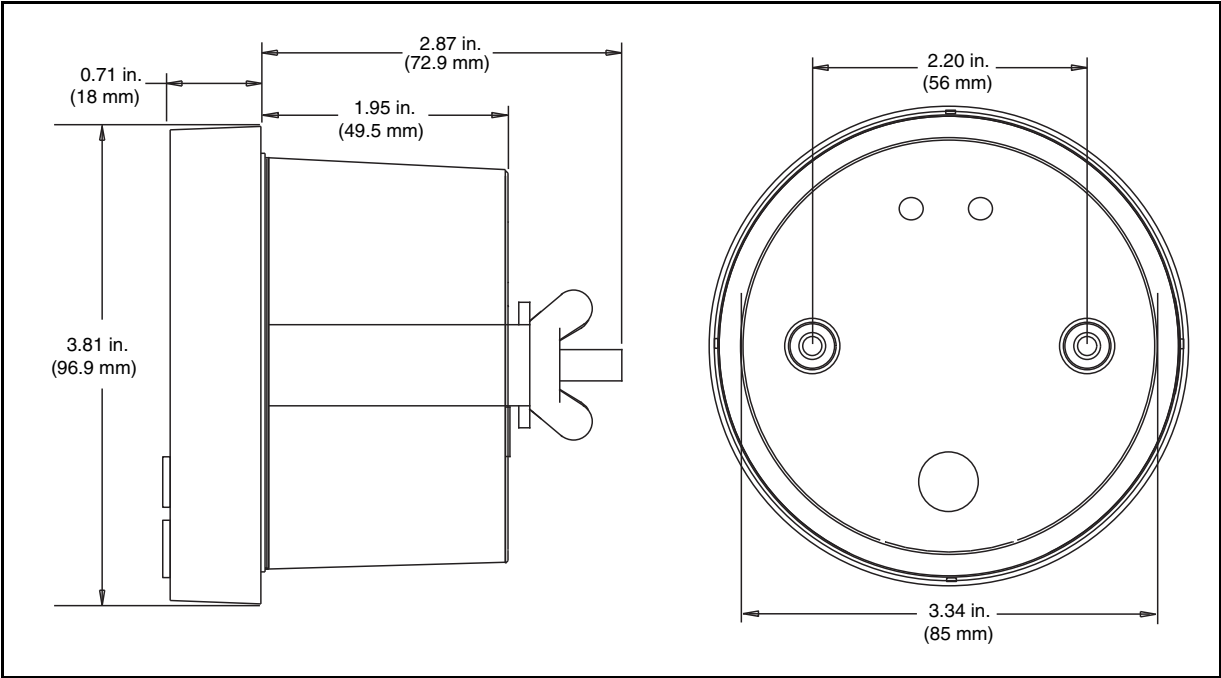

Warning Horn

Connect the yellow wire from the instrument to the black wire of the warning horn. Connect the blue wire from the instrument to the red wire of the warning horn. Each instrument should be installed with a warning horn. Mount each warning horn in a protected area and so horn is audible for operator.

Navigation Lights (Optional)

Connecting the light wiring for the *I-Command* instrument to the boat's navigation lights will provide instrument lighting if the instrument backlight setting is set to lowest setting and the boat's navigation lights are turned ON.

If desired, connect the white wire from the instrument to the switched positive (B+) of the boat's navigation lights and the black wire from the instrument to ground (GND).

Single Engine Power Supply Harness

Connect the red wire of the power supply harness to the purple switched B+ accessory wire of the ignition and trim/tilt wire harness. Connect the black wire of the power harness to the black ground wire of the ignition and trim/tilt harness.

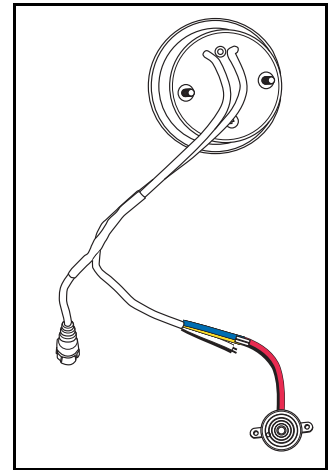

Warning Horn

Multiple Engine Power Supply Harness

Connect the purple wire(s) of the power supply harness to the purple switched B+ accessory wire of the ignition and trim/tilt wire harness(es). Connect the black wire of the power harness to a black ground wire of the ignition and trim/tilt harness. (Optional: connect the red wire of the power harness to a switched B+ power supply of the boat.)

Network Specifications

Network Buss Length

The maximum network buss length must not exceed 100 meters (328 ft.). Measure the distance from the t-connectors to the last device at each end of the network. Device cable lengths at the ends of the network must be included in the total network buss length calculation.

Devices

Install devices in any order. Install temperature, pressure and fluid level sensors, one device at a time. Configure the device, see “Advanced Operation” on page 59. If the device data does not display on a default page, add a page, see “Add Page” on page 34. Repeat this process for each device added to the network.

Device Cable Lengths

- Must not exceed 6 meters (19 ft.) for single device cable lengths
- Must not exceed 78 meters (256 ft.) for total device cable lengths

Maximum Number of Devices

A maximum of 50 devices can be attached to a network.

IMPORTANT: There should be no “open” or unused network device connectors. Remove unused network device connectors.

Load Equivalency

The *Engine Management Module (EMM)* on *Evinrude E-TEC* outboards has a load equivalency number of 1. Less than 50 mA of the network’s (CAN) power is used by the *EMM*.

Network Specification Diagram

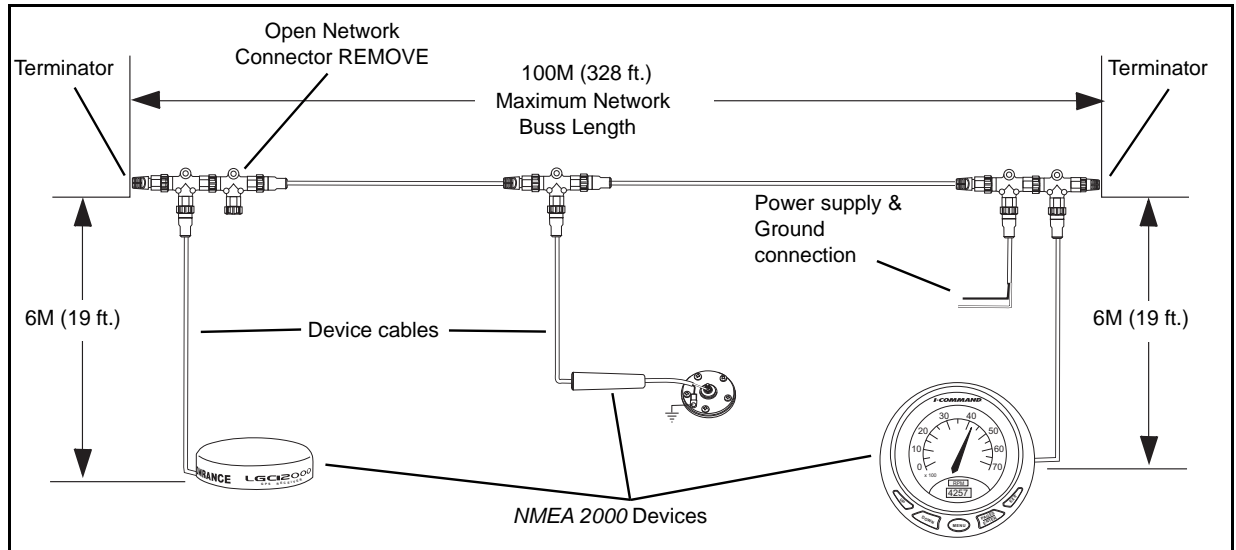

Device Net-style Connectors

I-Command and *NMEA 2000* networks use *DeviceNet* Micro-C type connectors. These connectors use 12 mm threaded locking rings and are waterproof when assembled properly. All *DeviceNet* Micro-C connectors are compatible with *I-Command* network connectors.

Connectors with slightly different appearances supplied with *I-Command* or *NMEA 2000* devices should NOT affect network operation. Always check pin and socket and locking ring configurations when installing connectors on a network.

Use the *I-Command Product Selection Guide*, P/N 764677, or a current *Accessories Parts Catalog* (2008 or newer) to look up part numbers for *I-Command* network connectors. See your dealer.

Connector Installation

Connectors have two configurations – Male (pins) and Female (sockets). Lubricate all connector gaskets with *Electrical Grease* before assembly.

Connectors should assemble easily. Do not force connectors or locking rings together.

If connectors do not match, an adapter cable may be available. See your dealer.

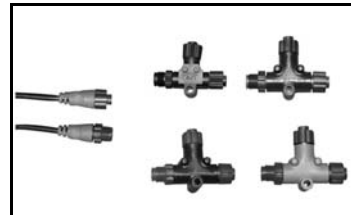

I-Command Network Connectors
(*DeviceNet*-style Connectors)



DeviceNet Micro-C connectors offered by other suppliers.

Terminating Resistors

Two terminating resistors are required for accurate network transmissions. Networks must be assembled with one terminator installed at each end of the *I-Command* network. See “Network Specification Diagram” on page 9.

T-connectors and Buss Cables

T-connectors provide each device access to the network. Single t-connectors have two buss connectors and one device connector. Network devices must be connected to the DEVICE connector of the t-connector.

T-connectors can be installed at the end of a network. Connect a network buss cable to one side and a terminator into the other.

Multiple t-connectors can be installed in the middle of a network. Network buss cables can be used to connect t-connectors or multiple t-connectors. See the “Network Specification Diagram” on page 9.

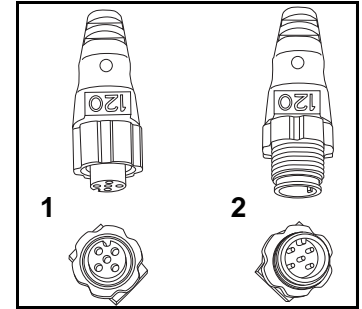

1. Female terminating resistor (sockets)
2. Male terminating resistor (pins)

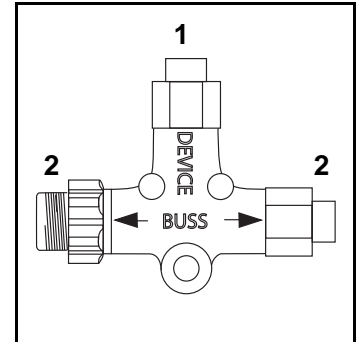

1. Device connector
2. Buss connector

Mounting Connectors

Mount t-connectors to flat mounting surfaces. Use washers or spacers behind the t-connector as needed. Check t-connector alignment. Incorrect mounting can damage the t-connectors resulting in broken wiring connections. T-connectors should be mounted with the DEVICE connector facing down to prevent water intrusion. Tighten screws by hand to prevent damage. Groups of t-connectors can be stacked for mounting in larger network installations.

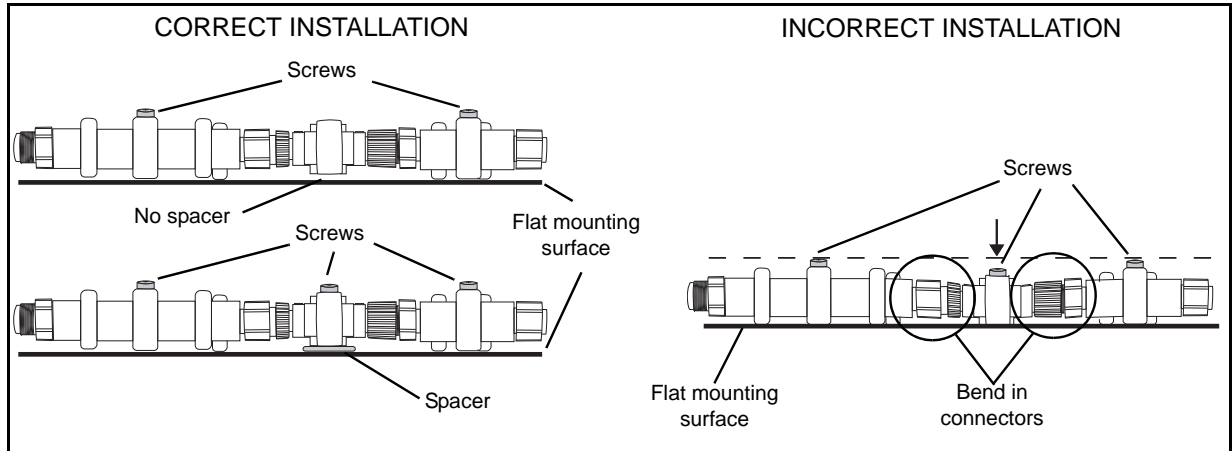

Network Setup

IMPORTANT: Set “ENGINE OPTIONS” on *Evinrude E-TEC* outboards before power is applied to the *I-Command* network.

Engine Options

Dealers must use *Evinrude Diagnostics* software to set “ENGINE OPTIONS”. Blank displays, or warning messages appear if engine options are not set. See your dealer to set the following “ENGINE OPTIONS”:

- Set multi engine identity (engine count and engine position)
- Calibrate trim sensor
- Activate water pressure transducer (if equipped with water pressure transducer, P/N 5008300)



Evinrude Diagnostics software, set engine options

Setup and Operation

Power Up

The displays and settings for this digital gauge are controlled by a five button keypad. The buttons are:

- **UP** and **DOWN** — Use to scroll through and choose menu items
- **MENU** — Use to open basic menu
- **PAGES / ENTER** — Use to scroll forward through pages, and to select menu items
- **EXIT**— Use to scroll backward through pages, close menus, and to return to a previous page

IMPORTANT: Make sure boat batteries are fully charged before beginning set up procedures. Low voltage on *I-Command* system can affect network performance. Always monitor network buss voltage during set up or when configuring network devices. See “Viewing Pass Code” on page 44. If network “buss” voltage falls below 12.5 volts, start the engine or connect a battery charger to the battery.

Turn the ignition key to the ON position. Starting the engine is not required.

1. The *Evinrude E-TEC* welcome screen will appear.
If the gauge then displays a data page, boat setup has been completed. Go to “Information Displays” on page 22.
2. If the gauge then displays the Boat Setup screen, boat setup must be completed before the gauge can be used. Go to “Boat Setup” on page 17.

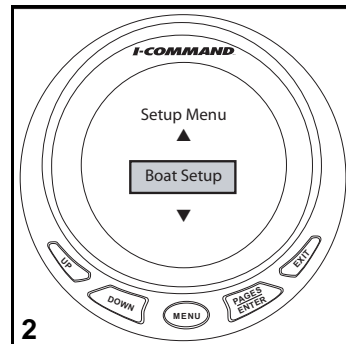
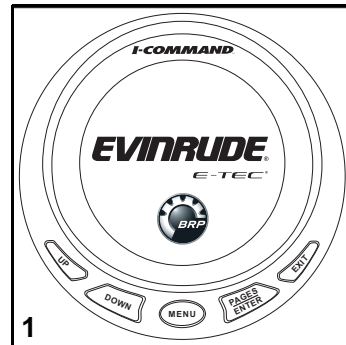

Boat Setup

Engine Set Up

When the *I-Command* Digital gauge powers up for the first time, the screen will show the Boat Setup menu.

Boat Setup must be complete before proceeding.

1. Press ENTER.
2. Press the UP button to set the number of engines installed on the boat.
I-Command gauges support up to eight engines.
Press ENTER when finished.

Continue Boat Setup with “Fuel Tank Set Up” on page 18.

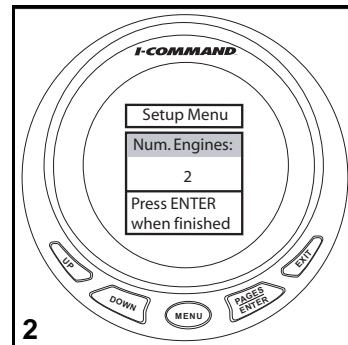
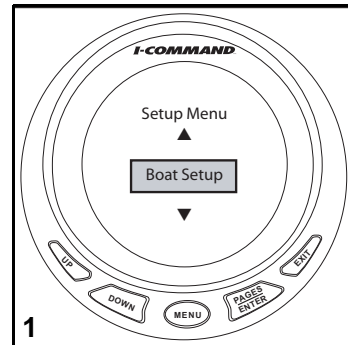

Fuel Tank Set Up

1. Use the UP or DOWN buttons to set the number of fuel tanks. *I-Command* gauges support up to five fuel tanks. Press ENTER to save selection.
2. Use the UP or DOWN buttons to select measurement units. Press ENTER to save selection.
3. Use the UP or DOWN buttons to set Vessel Fuel Capacity. This is the combined total capacity of all fuel tanks on the boat. Press ENTER when finished. Press the EXIT button to return to the tachometer.

Note: Fuel level senders used in some countries cause the gauge to read FULL when the tank is actually EMPTY. Calibrate fluid level sensors, see “Fuel or Fluid Level Sensor Calibration” on page 63, to correct gauge reading.

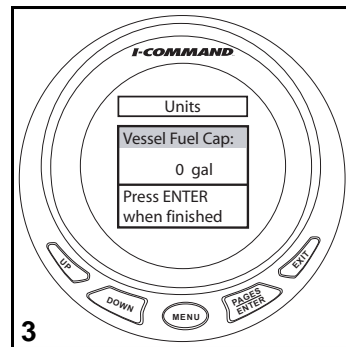
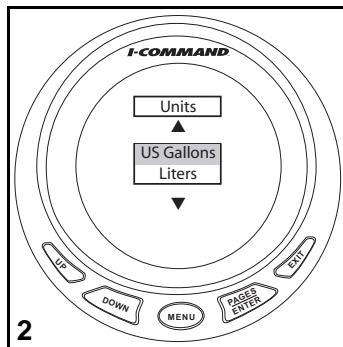
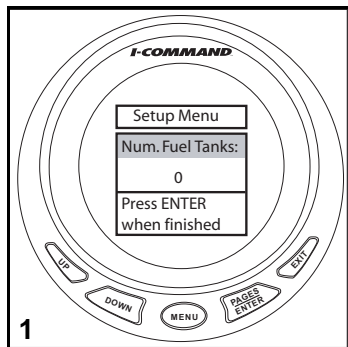

Configure Fuel Tank Capacity

The capacity of each tank must be entered.

1. Press MENU. Use the UP or DOWN buttons to select SYSTEM SETUP.
Press ENTER.
2. Use the UP or DOWN buttons to select BUS DEVICES.
Press ENTER.
The gauge will search for devices.
3. Use the UP or DOWN buttons to select the fuel tank to configure.
Press ENTER.

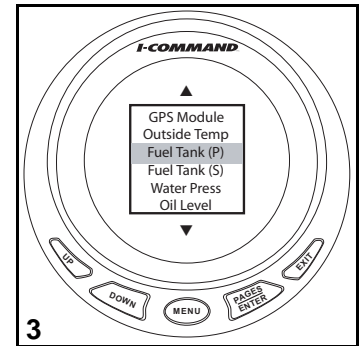
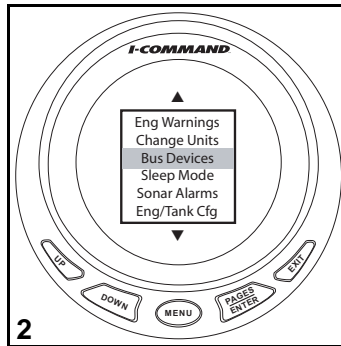
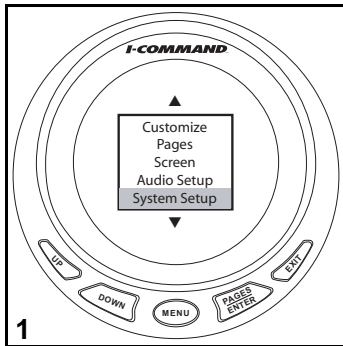

4. Use the UP or DOWN buttons to select RECONFIGURE. Press ENTER.
5. Use the UP or DOWN buttons to select FUEL. Press ENTER.
6. Use the UP or DOWN buttons to select the fuel tank to be configured. Press MENU.
7. Use the UP or DOWN buttons to set the fuel tank capacity. Press ENTER when finished.

Repeat steps 1 through 7 to configure each fuel tank.

For single fuel tank boats, Boat Setup is complete. Go to “Information Displays” on page 22. For multi-engine boats, go to “Engine Data” on page 21.

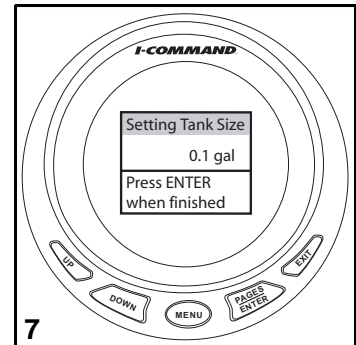
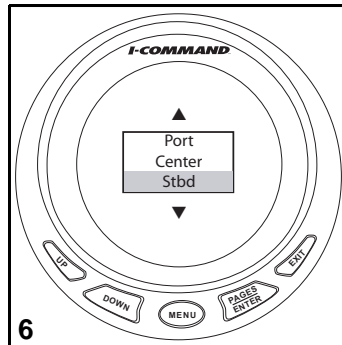
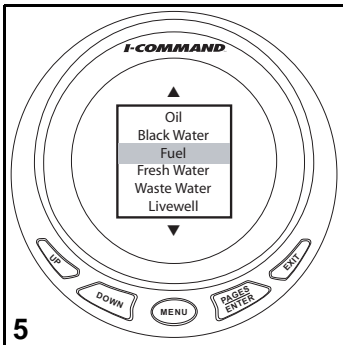
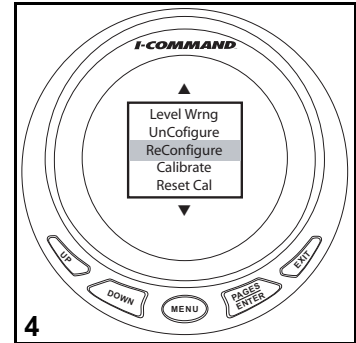

Engine Data

The *I-Command* system monitors up to eight engines. The ENGINE DATA option assigns each *I-Command* gauge to monitor a specific engine.

Note: This option displays only when two or more engines are connected to the network.

1. Press MENU. Use the UP or DOWN buttons to select SYSTEM SETUP. Press ENTER.
 2. Use the UP or DOWN buttons to select ENGINE DATA. Press ENTER.
 3. Use the UP or DOWN buttons to select engine. Press ENTER.
- Repeat this process to assign each gauge to monitor an engine.

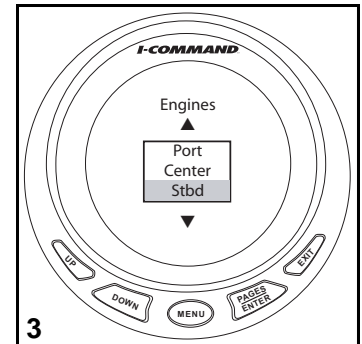
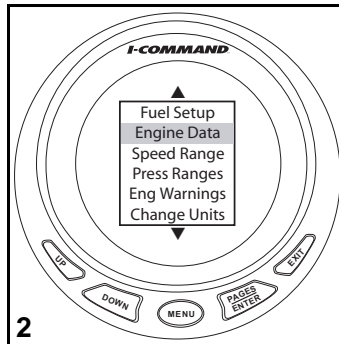
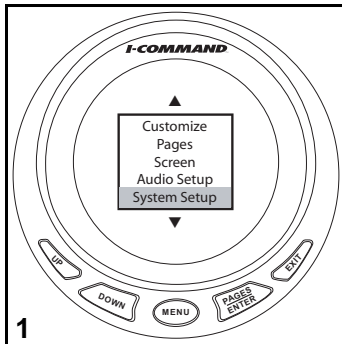

Information Displays

Information Displays are known as “Pages.” Pages are an essential part of the *I-Command* Digital gauge. Press the ENTER or EXIT button repeatedly to scroll through the default pages.

There are seven default pages:

- Tachometer - displays engine rpm
 - Speedometer - displays ground speed (GND:S)
 - Fuel Level - displays fuel level percent (FUL:L)
 - Engine Trim - displays engine trim percent
- Note:** The trim feature is not available on 90 HP and smaller *Evinrude E-TEC* models.

- Battery Volts (Batt V) - displays battery voltage
- Engine temperature (Eng Temp) - displays engine operating temperature. in degrees Fahrenheit or Celsius. See “Change Units” on page 28 to customize this display.
- Fuel Flow - displays default fuel management information of ground speed, fuel remaining (Fuel Rem), and fuel level. See “Fuel Management Options” on page 68 to customize this display.

The *I-Command* gauges are ready for operation.

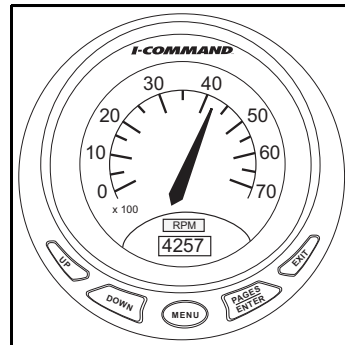

Tachometer

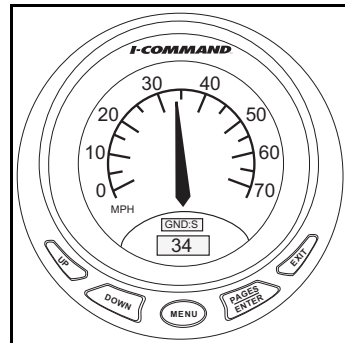

Speedometer

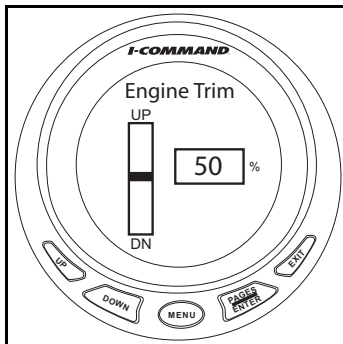

Engine Trim

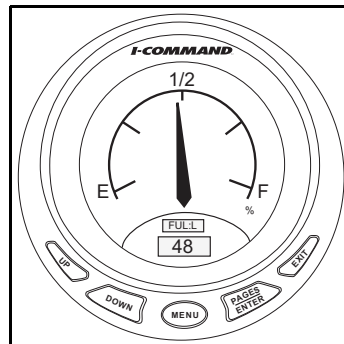

Fuel Level

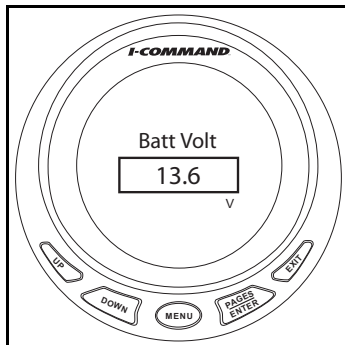

Battery Voltage

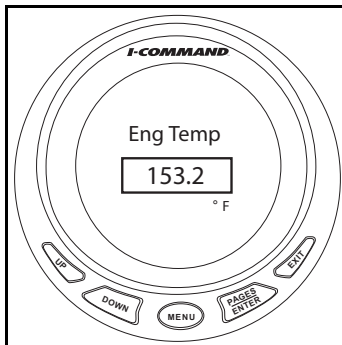

Engine Temperature

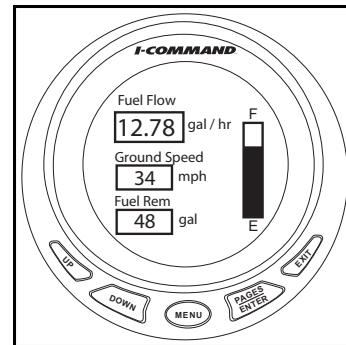

Fuel Flow

Screen Settings

Change the screen settings to improve visibility.

1. Press MENU. Use UP or DOWN buttons to select SCREEN.
Press ENTER.

Change Contrast

2. Use UP or DOWN buttons to select CONTRAST.
Press ENTER.
3. Use UP button to darken or DOWN button to lighten contrast.
Press ENTER when finished.

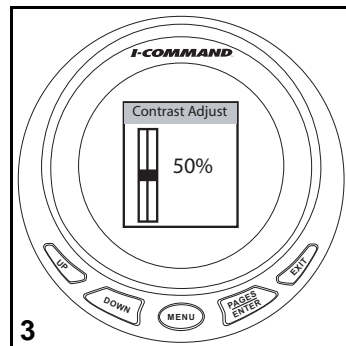
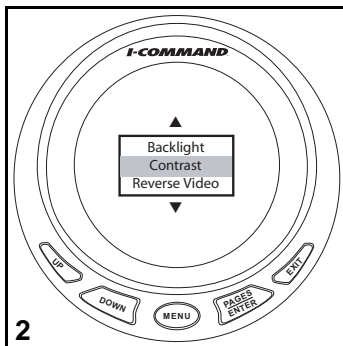
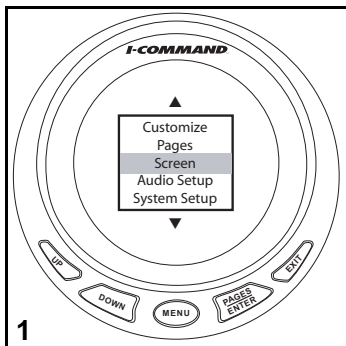

Backlight Sync

Turn Backlight Sync (Blight Sync) ON to synchronize the lighting of all gauges. Turn Blight Sync OFF to manually adjust the lighting of individual gauges.

4. Use UP or DOWN buttons to select BACKLIGHT. Press ENTER.
5. Use the UP or DOWN buttons to select BLIGHT SYNC. Press ENTER.
6. Use UP or DOWN buttons to select OFF or ON. Press ENTER when finished.

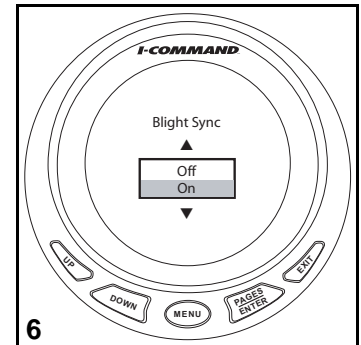
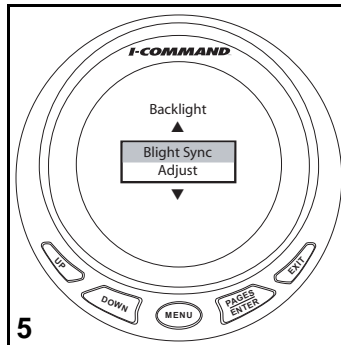
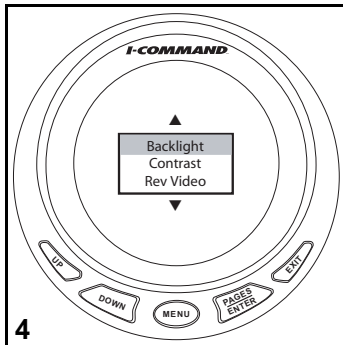

Adjust Backlight

Adjust sets brightness of backlighting from 0 to 100%.

7. Use UP or DOWN buttons to select BACKLIGHT. Press ENTER.

8. Use the UP or DOWN buttons to select ADJUST. Press ENTER.

9. Use the UP button to brighten the backlight.

Use the DOWN button to dim the backlight.

Press ENTER when finished.

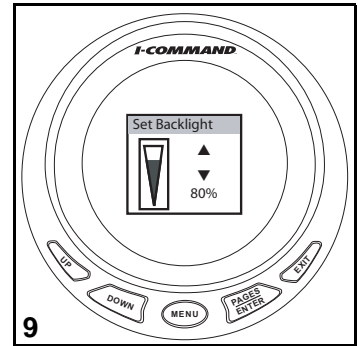
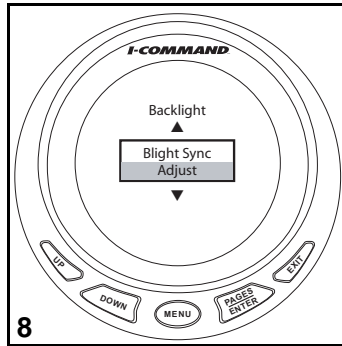
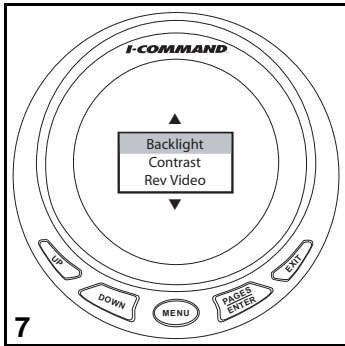

Reverse Video

10. Use UP or DOWN buttons to select REVERSE VIDEO. Press ENTER.

Press ENTER to toggle the screen from the light background (11) to the dark background (12).

Press EXIT when finished.

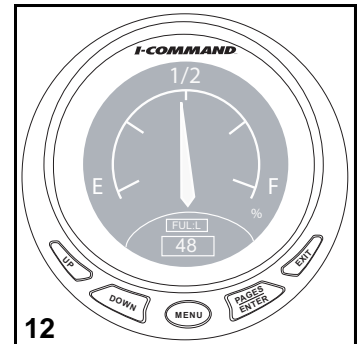
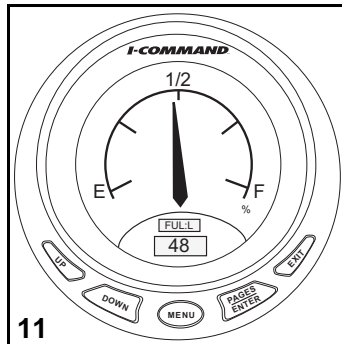
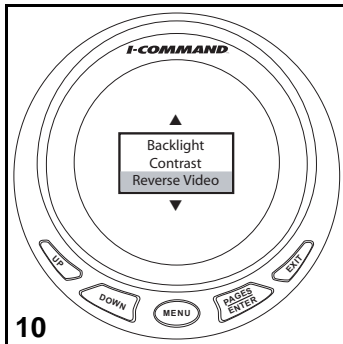

Change Units

This example will change the water pressure gauge display from imperial units, to metric units. Use this process to change other units available in the units menu (see step 3).

1. Press MENU. Use the UP or DOWN buttons to select SYSTEM SETUP. Press ENTER.
2. Use the UP or DOWN buttons to select CHANGE UNITS. Press ENTER.

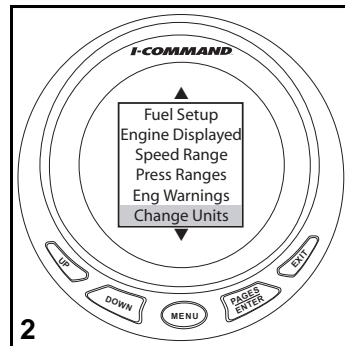
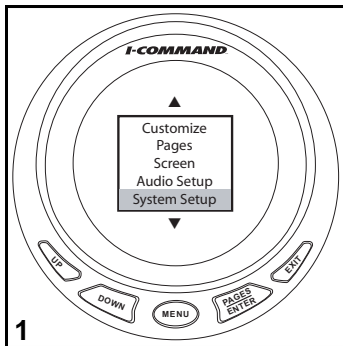
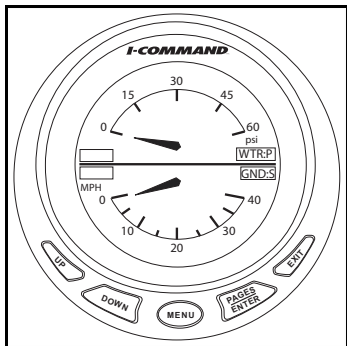

3. Use the UP or DOWN buttons to select PRESSURE.
4. Use the UP or DOWN buttons to select desired units.
Press ENTER.
5. Gauge will now display selected units.

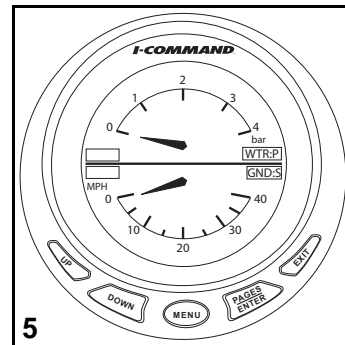
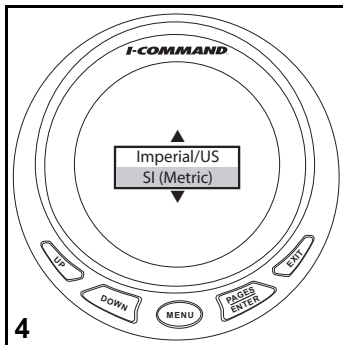
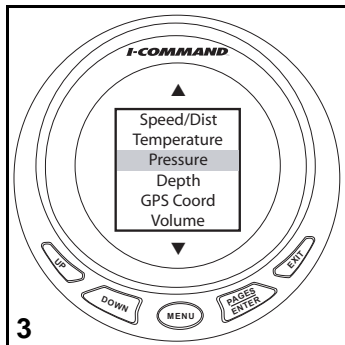

Customizing Displays

Fuel Manager

Use the Fuel Manager to track the following fuel consumption information:

- Throttle Percentage
- Fuel Economy
- Fuel Remaining
- Fuel Range
- Seasonal Fuel
- Fuel Flow
- Fuel Consumption
- Fuel Used
- Trip Fuel Used

Also see “Fuel Management” on page 66.

This example shows how to select the data to be displayed.

1. Press the ENTER or EXIT button repeatedly to scroll to the Fuel Manager page. Note the center data box is Ground Speed.
2. Press MENU.
Use the UP or DOWN buttons to select CUSTOMIZE.
Press ENTER.

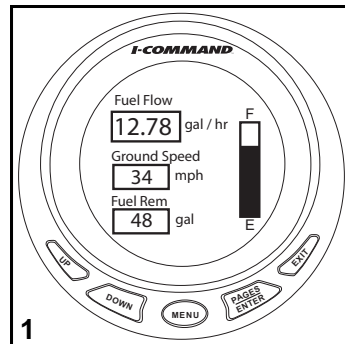

1

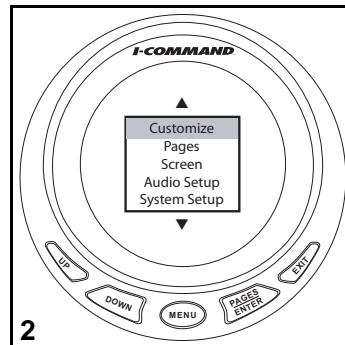

2

3. Use UP or DOWN buttons to select CENTER DATA.
Press ENTER.
4. Press UP or DOWN button to select FUEL ECONOMY.
Press ENTER.
5. Press EXIT twice to return to fuel manager page.

Fuel Economy (MPG) is now displayed. Other data boxes can be changed similarly.

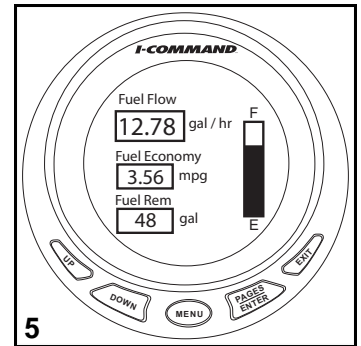
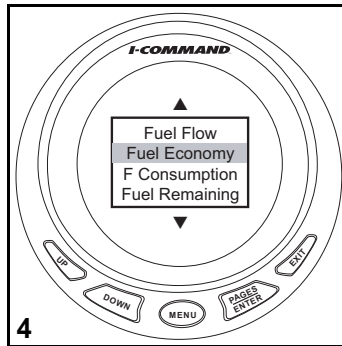
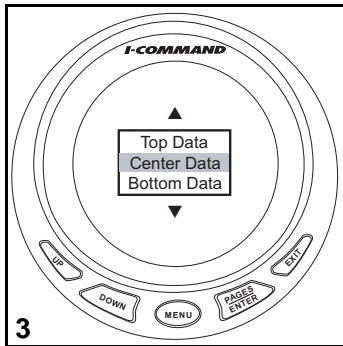

Add Page

Use Add Page to display additional data when temperature, pressure, fluid level, or other sensors are added to the network. See “Devices” on page 8. Also use Add Page to customize user preferences. Pages display in analog or digital format using single, dual, or quad displays.

Eight additional pages can be added. They are:

- Trim Tabs - requires sending unit
- GPS Position - requires GPS module
- Rudder - requires sending unit
- Clock - requires GPS module
- Fuel Manager (labeled as Fuel Flow, also a default page)
- Engine Trim (also a default page)
- Engine Diagnostics
- Compass - requires GPS module
- Synchronizer – displays RPM for two to eight engines, allowing users to synchronize the engines for smoother performance.

This example adds the Engine Diagnostics page.

1. Press MENU.
Use UP or DOWN buttons to select PAGES.
Press ENTER.
2. Press ENTER to select ADD PAGE.

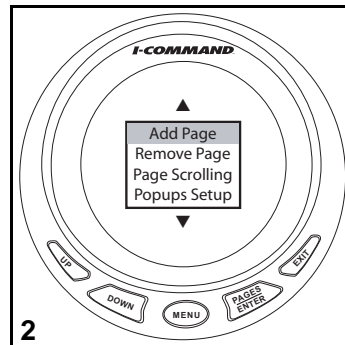
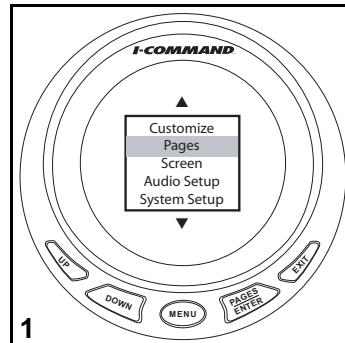

3. Use the UP or DOWN buttons to select Diagnostics.
Press ENTER.
4. Press ENTER again to confirm.
5. The Engine Diagnostic page will now display.

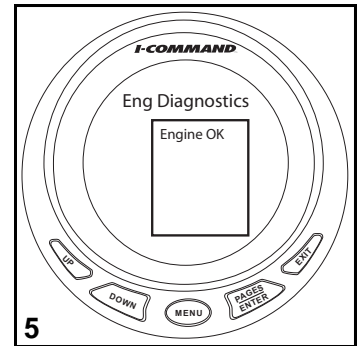
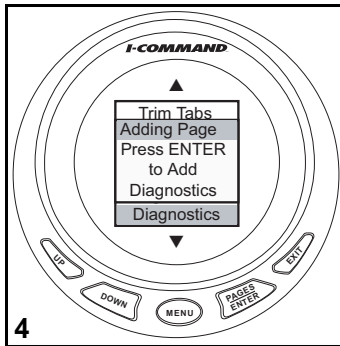
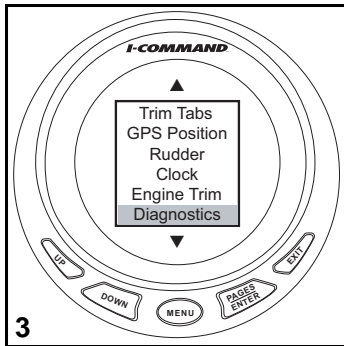

Add Analog Page

The following data can be displayed by an analog page:

- Alt Voltage
- Atmospheric Pressure
- Battery Voltage
- Engine Temp
- Fluid Level
- Engine Water Pressure
- GPS Speed (speed over ground)
- Paddle Wheel Speed (speed over water)
- Pitot Speed
- Tachometer
- Temperature

This example adds a dual analog gauge display. Select single analog or quad analog to display those options.

1. Press MENU.
Use UP or DOWN buttons to select PAGES.
Press ENTER.
2. Press ENTER to select ADD PAGE.

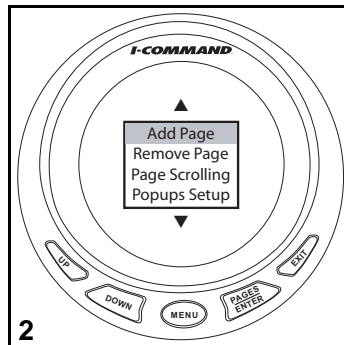
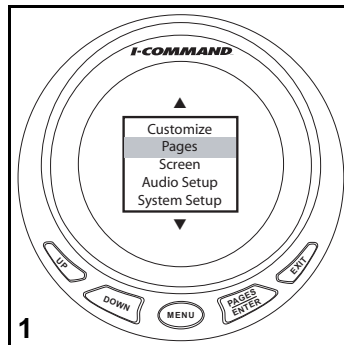

3. Press UP button to select DUAL ANALOG.
Press ENTER.

Press ENTER.

4. Press ENTER again to confirm.

The Dual Analog gauge will now display.

To change the default data displayed on any single, dual or quad analog gauge, see "Customizing Displays" on page 40.

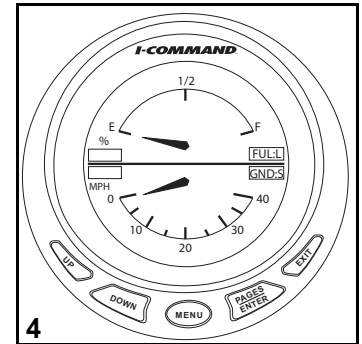
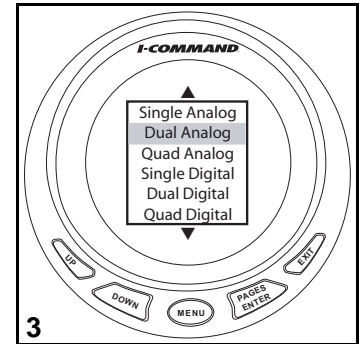

Add Digital Page

The following data can be displayed by a digital page:

- Alt Voltage
- Atmospheric Pressure
- Battery Voltage
- Depth
- Engine Temperature
- Fuel Economy
- Fuel Flow
- Fuel Range
- Fuel Consumption
- Fuel Used
- Trip Fuel Used
- Fuel Remaining
- Seasonal Fuel Used
- GPS Speed (speed over ground)
- Paddle Wheel Speed (speed over water)
- Pitot Speed
- Tachometer
- Temperature
- Total Engine Hours
- Throttle Percentage
- Engine Water Pressure
- Time

This example adds a quad digital display. Select single digital or dual digital to display those options.

1. Press MENU.
Use UP or DOWN buttons to select PAGES.
Press ENTER.
2. Press ENTER to select ADD PAGE.

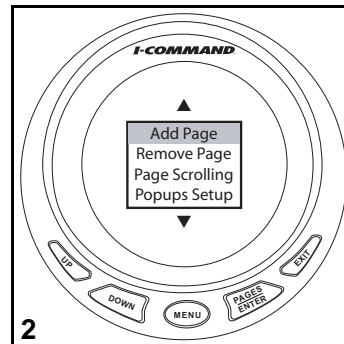
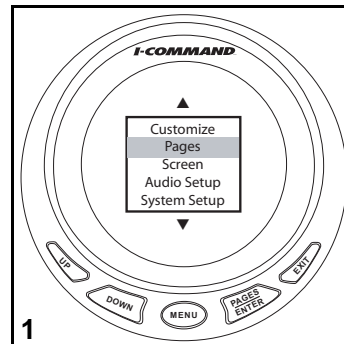

3. Use UP or DOWN buttons to select QUAD DIGITAL.

Press ENTER.

4. Press ENTER again to confirm.

The Quad Digital gauge will now display.

To change the default data displayed on any single, dual or quad digital display, see “Customizing Displays” on page 40.

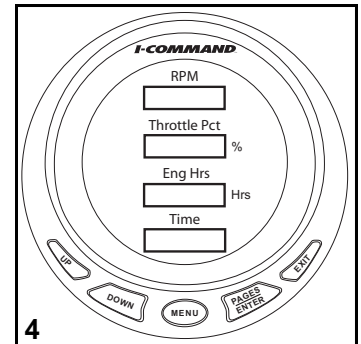
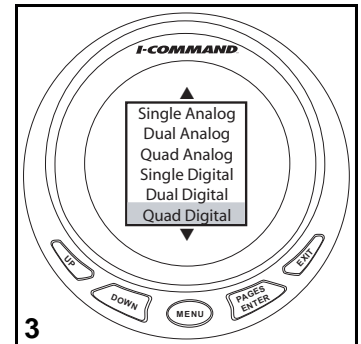

Customizing Displays

Change Default Display

When adding pages, each single, dual or quad page has a default display. Use the CUSTOMIZE menu to change default display data on a page.

1. Press ENTER or EXIT button multiple times to scroll to page to customize.
Press MENU.
2. Use UP or DOWN buttons to select CUSTOMIZE.
Press ENTER.
3. Use UP or DOWN buttons to select GAUGE (if analog), or DATA BOX (if digital).
Press ENTER.

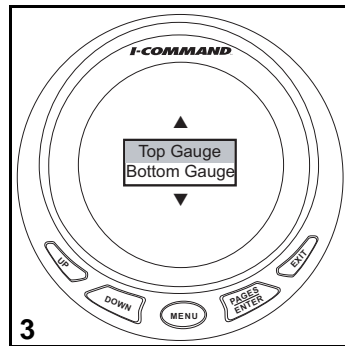
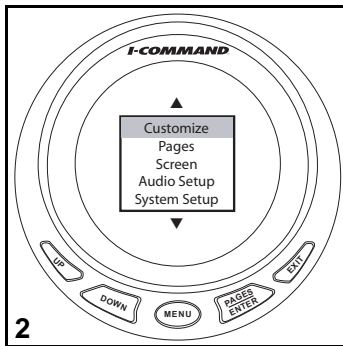
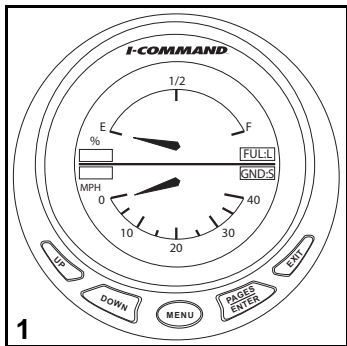

4. Use UP or DOWN buttons to select desired display item.
Press ENTER.
5. Press EXIT once to return to Step 3 to change remaining items.
Press EXIT multiple times to return to display.
Display change will now appear.

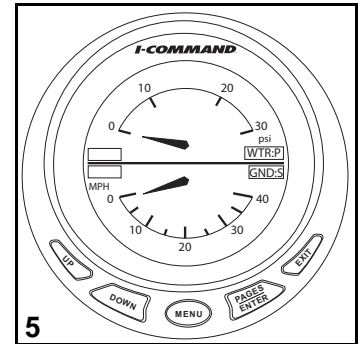
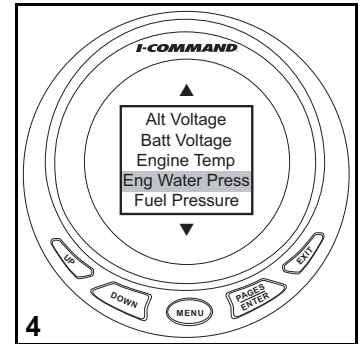

Configure Time Display

1. Press MENU.
Use UP or DOWN buttons to select SYSTEM SETUP.
Press ENTER.
 2. Use UP or DOWN buttons to select TIME CONFIG.
Press ENTER.
 3. Use UP or DOWN buttons to select:
HOUR FORMAT, go to Step 4.
SHOW SECONDS, go to Step 5.
TIME ZONE go to Step 6.
- Note:** The SHOW SECONDS option is NOT available if time is selected as part of a QUAD DIGITAL display. See “Add Digital Page” on page 38.

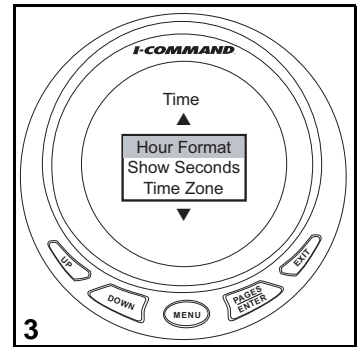
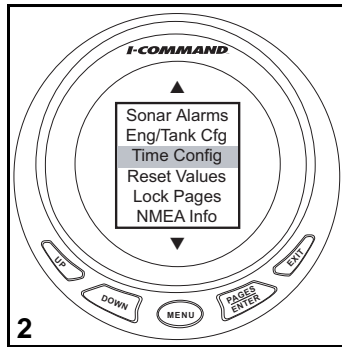
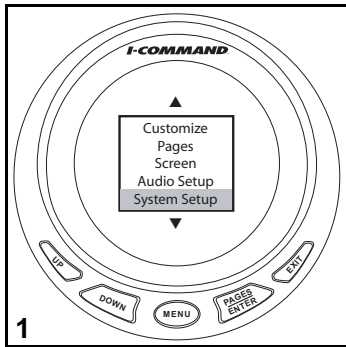

- Use UP or DOWN buttons to select 12 or 24 hour display option.
Press ENTER.
- Use UP or DOWN buttons to select YES or NO.
Press ENTER.
- Use UP or DOWN buttons to select Time Zone.
Press ENTER.
- Press EXIT multiple times to return to time display.

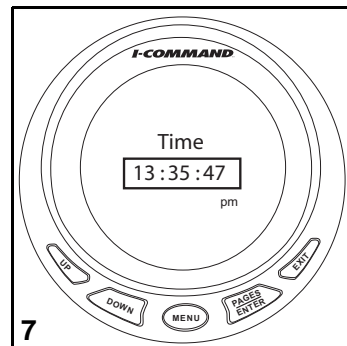
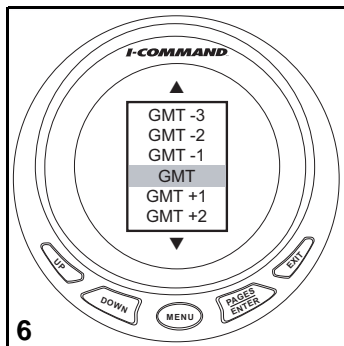
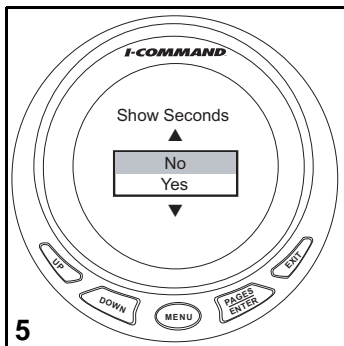
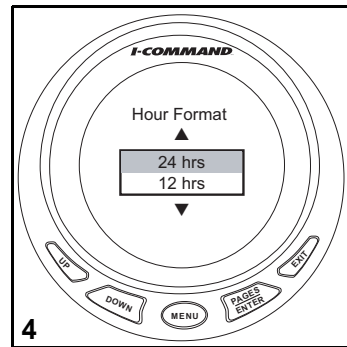

Lock Pages

The Lock Pages feature prevents unauthorized users from changing selected settings.

Viewing Pass Code

If you have the PASS CODE, skip to step 4.

1. Press MENU. Use UP or DOWN buttons to select SYSTEM SETUP. Press ENTER.
2. Select NMEA INFO and press ENTER.
3. PASS CODE is the last four digits of the SERIAL NUMBER. Also use this page to monitor buss voltage.

For easy reference, write gauge serial number here: _____

Press EXIT to return to the MENU.

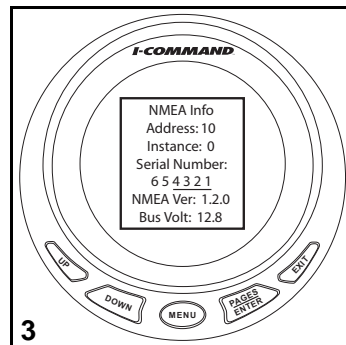
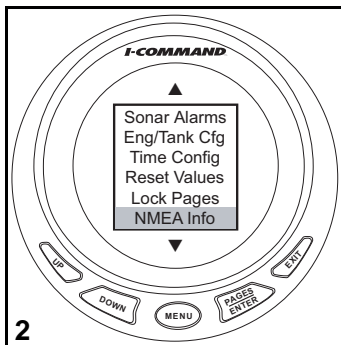
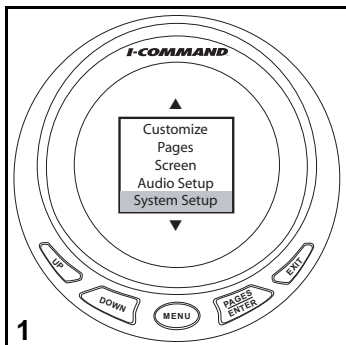

Select Pages to Lock

- Use the UP or DOWN buttons to select LOCK PAGES.
Press ENTER.
- Use the UP or DOWN buttons to change the active digit.
Use the MENU button to select the next digit.
Press ENTER to submit PASS CODE.
- Use the UP or DOWN buttons to scroll through the list. Press the MENU button to view the next list.
Press ENTER to select page(s) to be locked. An "x" will appear in the box when a page is selected.
Press EXIT when selection is complete.

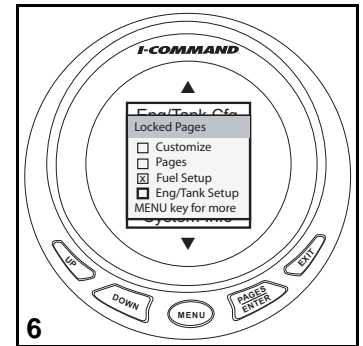
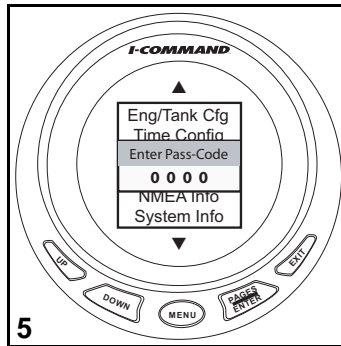
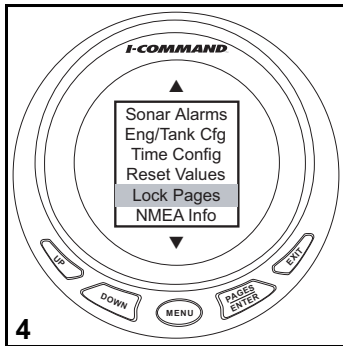

Accessing a Locked Page

A locked page requires pass code entry to access and make changes to the locked page. FUEL SETUP is locked in this example.

1. Press MENU.
Use UP or DOWN buttons to select SYSTEM SETUP.
2. Select desired page and press ENTER.
3. Enter the gauge PASS CODE.
Use the UP or DOWN buttons to change the active digit.
Use the MENU button to select the next digit.

Press ENTER to submit PASS CODE.

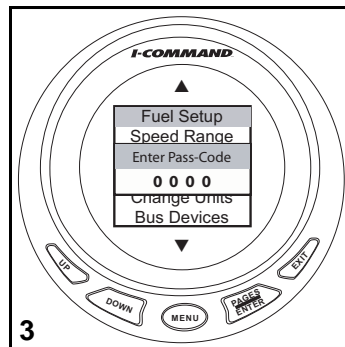
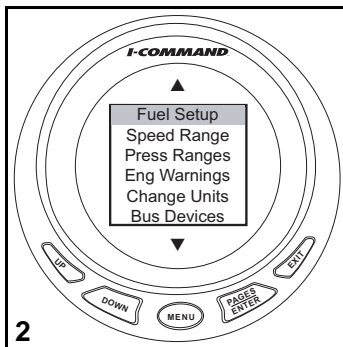
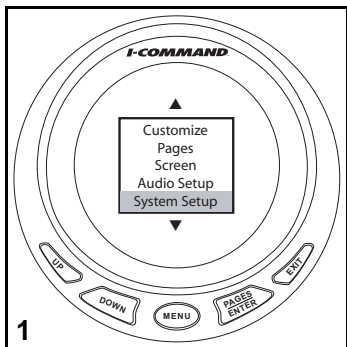

- An incorrect entry will result in an INVALID CODE message.
Press ENTER to start over.
- Correct entry of pass code allows access to page.
Use UP or DOWN buttons to select items and make changes.
- When finished, press ENTER to return to gauge display.

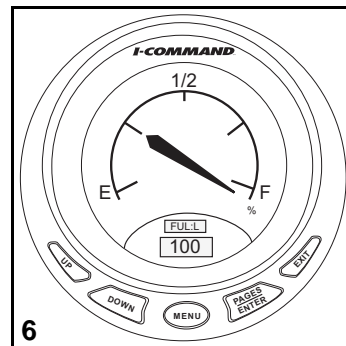
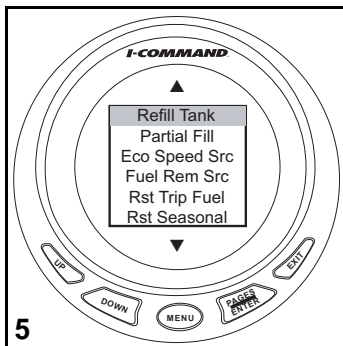
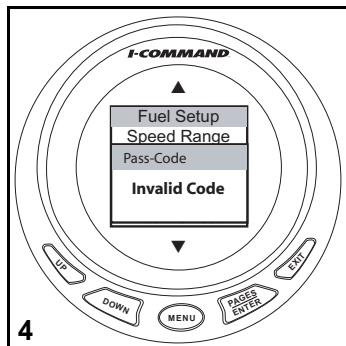

Removing Pages

1. Press the ENTER or EXIT button to scroll to the page to be removed.
Press MENU.
2. Use UP or DOWN buttons to select PAGES.
Press ENTER.

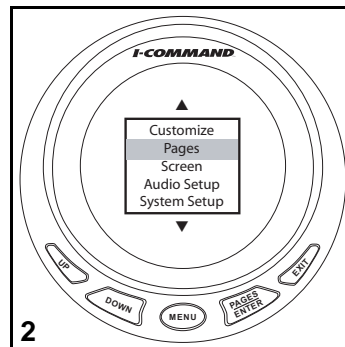
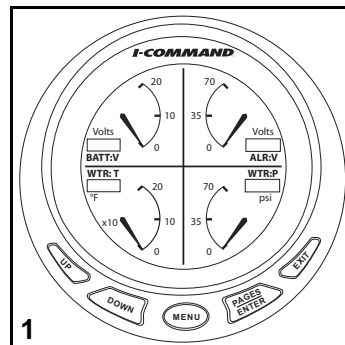

3. Use UP or DOWN buttons to select REMOVE PAGE.
Press ENTER.
 4. A confirmation message will appear.
Press ENTER to remove page.
- The display will return to the next page.

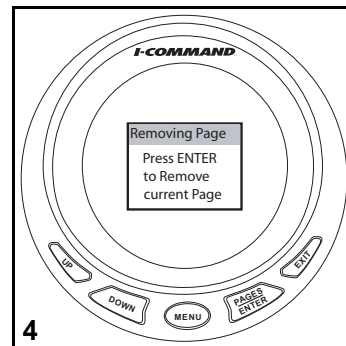
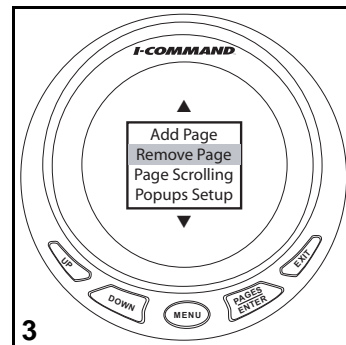

Page Scrolling

Pages can be viewed automatically or by manual scrolling.

Manual

To scroll through pages manually, use the ENTER and EXIT buttons to view pages.

Automatic

To scroll through pages automatically, a viewing interval must be selected.

1. Press MENU.
Use the UP or DOWN buttons to select PAGES.
Press ENTER.
2. Use the UP or DOWN buttons, select PAGE SCROLLING.
Press ENTER.

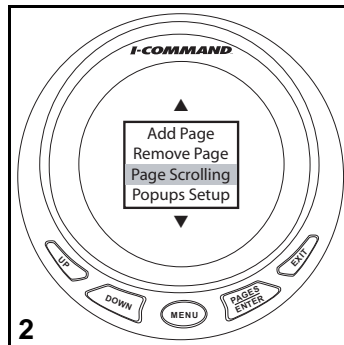
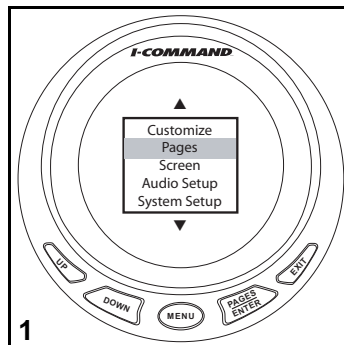

3. Use the UP or DOWN buttons to select SET TIME.

Press ENTER.

4. Use the UP or DOWN buttons to set time.

Select an interval from one to sixty seconds.

Press ENTER to set automatic scrolling interval.

Note: To turn off automatic page scrolling, repeat the first two steps. When the Page Scrolling menu appears, select OFF. Then press ENTER.

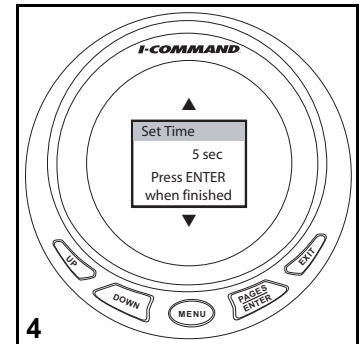
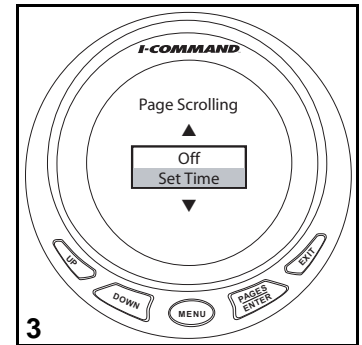

Pop-Ups

The Pop-Up feature alerts users when changes occur in a monitored category (RPM, Engine Trim, Trim Tabs or Rudder). Pop-ups appear when a user-specified incremental measurement is met. When an increment changes, the main page for the category will pop up on the main display for a preset duration. See “Stay-On Time” on page 54 to set pop-up duration.

Setting a Pop-Up

This example illustrates setting the RPM Pop-Up. Engine trim, trim tabs and rudder are set up similarly.

1. Press MENU.
Use UP or DOWN buttons to select PAGES.
Press ENTER.
2. Use the UP or DOWN button to select POP-UPS SETUP.
Press ENTER.

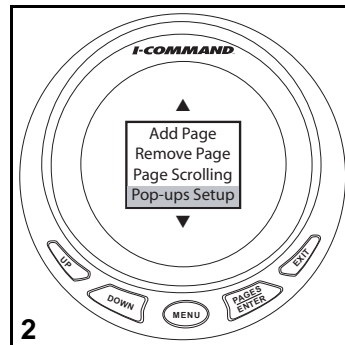
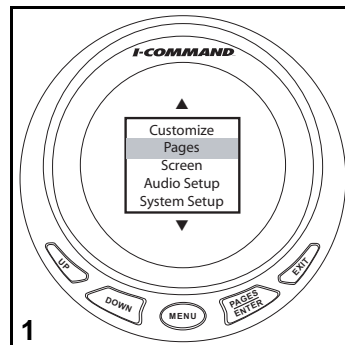

3. Use the UP or DOWN button to select RPM.

Press ENTER.

4. Use the UP or DOWN button to select:

- OFF to turn off the pop-up, or
- SET THRESHOLD to activate the pop-up.

Press ENTER.

5. The threshold for RPM is 50 to 3,000 RPM. Use the UP or DOWN buttons to set the desired value to activate the pop-up.

Press ENTER when finished.

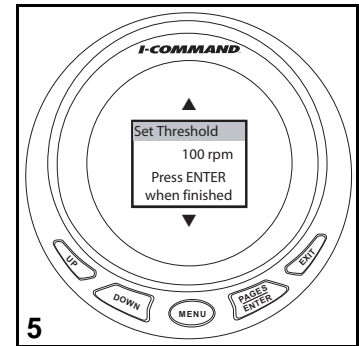
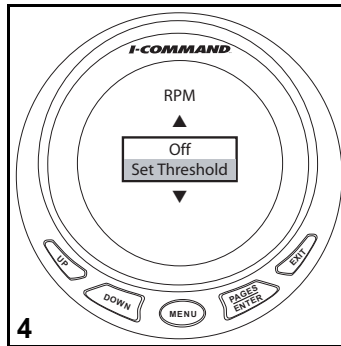
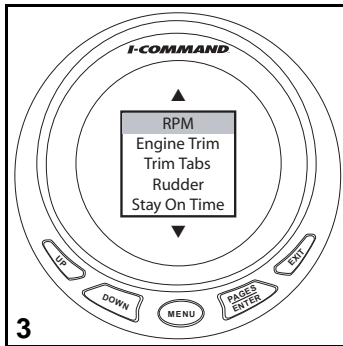

Stay-On Time

Use the Stay-on Time feature to adjust the duration of time a Pop-Up window remains visible. See “Setting a Pop-Up” on page 52.

1. Press MENU.
Use UP or DOWN buttons to select PAGES.
Press ENTER.
2. Use the UP or DOWN button to select POPUPS SETUP.
Press ENTER.

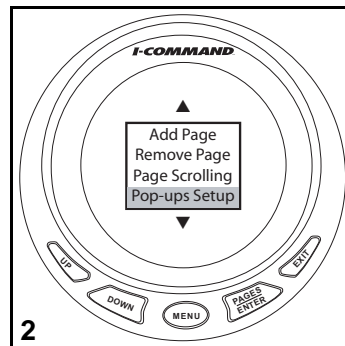
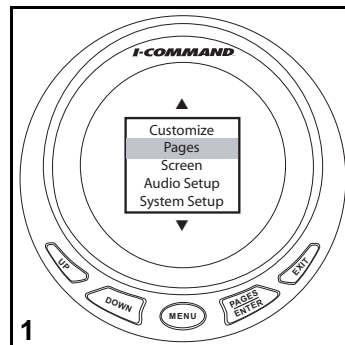

3. Use the UP or DOWN buttons to select STAY-ON TIME.
Press ENTER.
4. The stay-on time is two to fifteen seconds. Use the UP or DOWN buttons to set the stay-on time.

Press ENTER when finished.

Note: The stay-on time selected applies to all monitored categories.

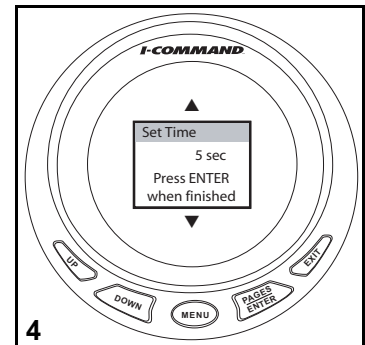
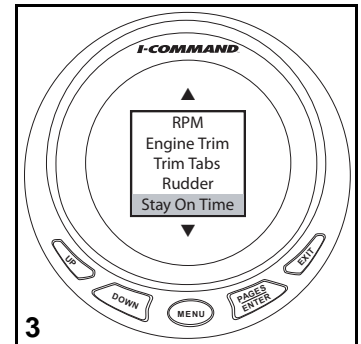

Sleep Mode

Sleep mode allows the *I-Command* gauge to enter a power-save status to keep from overdrawing the boat power source.

Note: The Sleep Mode default setting is ON.

1. Press MENU.
Use the Up or DOWN buttons to select SYSTEM SETUP.
Press ENTER.
2. Use the UP or DOWN button to select SLEEP.
Press ENTER.

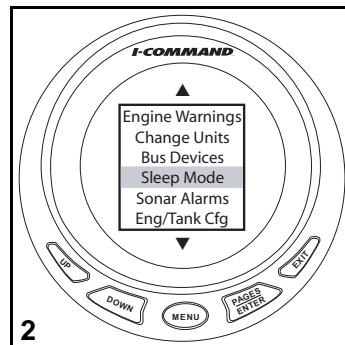
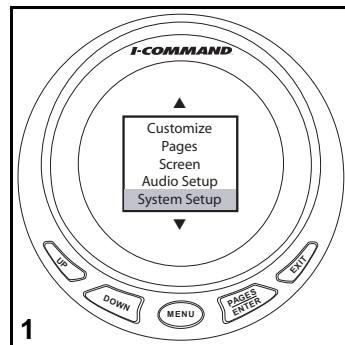

3. Use the UP or DOWN buttons to select ON or OFF.
Press ENTER. Gauge will return to last display.

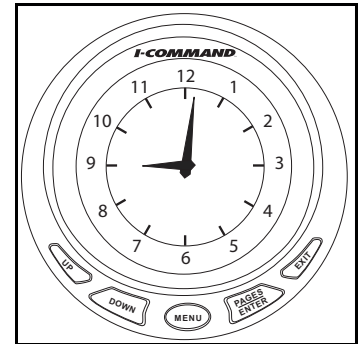
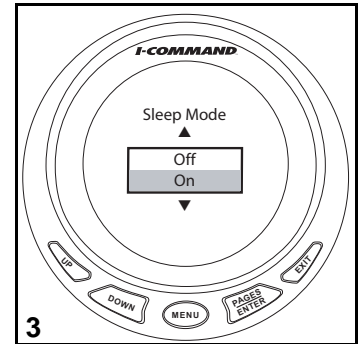

Advanced Operation

Configure Fluid Level Sensor

This example configures a Fluid Level Sensor for the second of two fuel tanks. Use this process to set up fluid level sensors for other fluid tanks.

1. Press MENU. Use the UP or DOWN buttons to select SYSTEM SETUP.
Press ENTER.
2. Use the UP or DOWN buttons to select BUS DEVICES.
Press ENTER.
3. The gauge will search for devices.

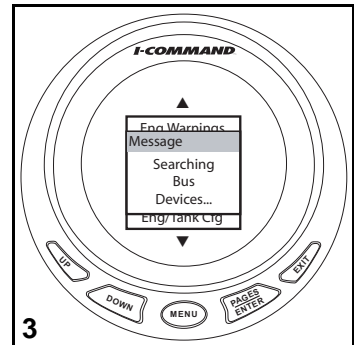
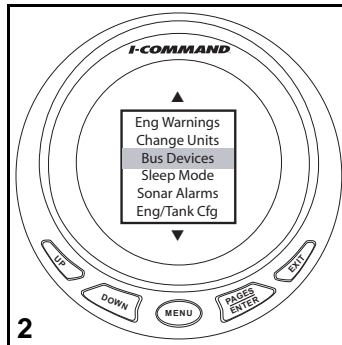
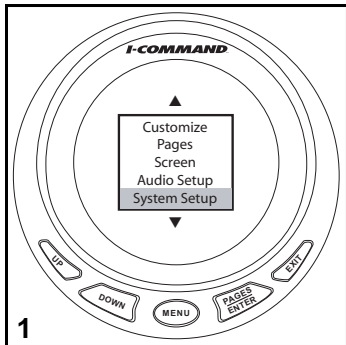

4. Use the UP or DOWN buttons to select UNCFG F LEV.
Press ENTER.
5. Press ENTER to configure Fluid Level Sensor.
6. Use the UP or DOWN buttons to select FUEL.
Press ENTER.

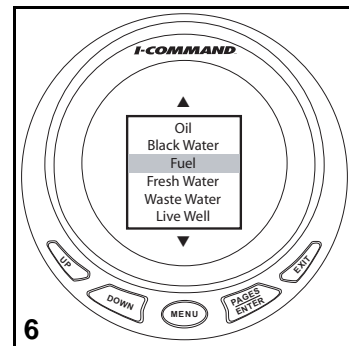
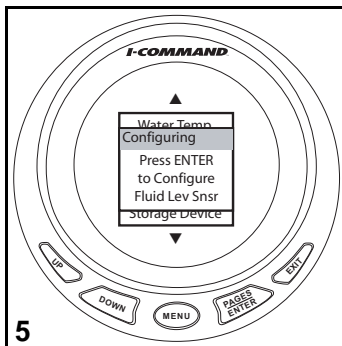
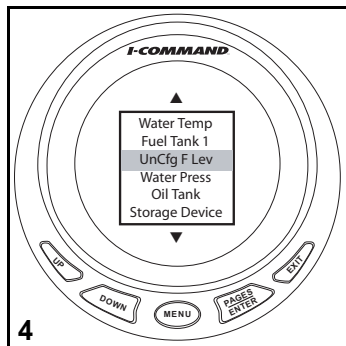

7. Use the UP or DOWN buttons to select the tank.

Press ENTER.

8. The gauge will change the tank setting and return to the BUS DEVICES list.

Proceed to “Fuel or Fluid Level Sensor Calibration” on page 63.

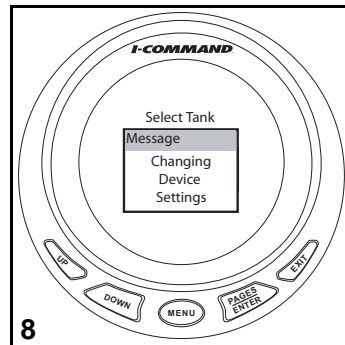
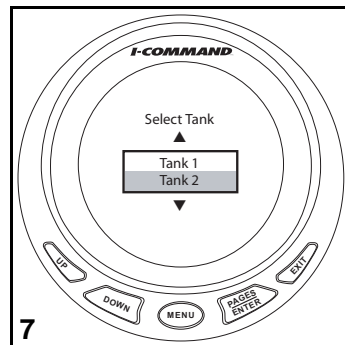

Fuel or Fluid Level Sensor Calibration

Fluid level sensors rely on the tank sending unit to calculate remaining fluid level. Fluid level reading is dependent on sending unit accuracy and capacity entered during setup. A FIVE POINT calibration is the most accurate.

- Two-Point calibrates EMPTY and FULL levels.
- Three-Point calibrates EMPTY, 50% and FULL levels.
- Five-Point calibrates EMPTY, 25%, 50%, 75% and FULL levels.

WARNING

Running out of fuel could cause the operator of the boat to have diminished or no control of the vessel, presenting a risk of personal injury to the operator, passengers, and people who are nearby.

This example illustrates a 2-Point Calibration. Follow the on-screen prompts if a Three or Five-Point Calibration is desired.

IMPORTANT: The tank should be EMPTY before starting calibration. After adding fluid to the tank, allow a few seconds for the sending unit to stabilize before pressing ENTER.

1. Press MENU. Use the UP or DOWN buttons to select SYSTEM SETUP. Press ENTER.
2. Use the UP or DOWN buttons to select BUS DEVICES. Press ENTER.

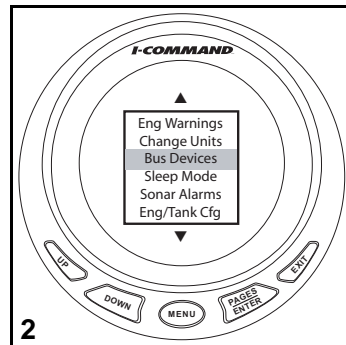
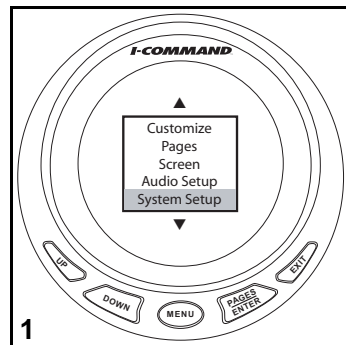

3. The gauge will search for devices.
4. Use the UP or DOWN buttons to select the device to be calibrated. Press ENTER.
5. Use the UP or DOWN buttons to select CALIBRATE. Press ENTER.
6. Use the UP or DOWN buttons to select the number of points for the calibration. Press ENTER.

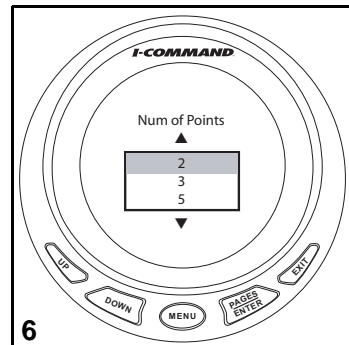
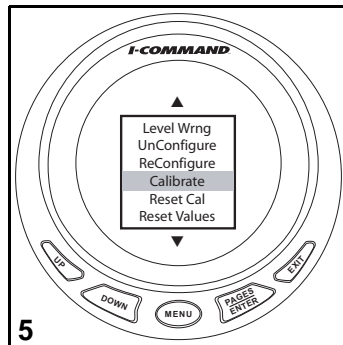
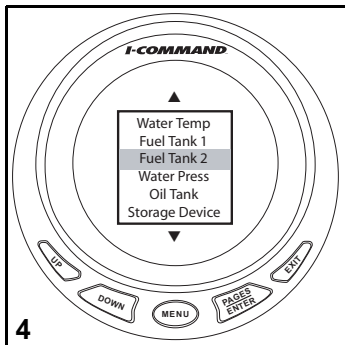
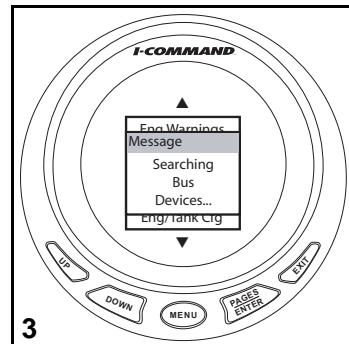

7. Select EMPTY LEVEL.

Press ENTER.

8. Be sure the tank is EMPTY.

Press ENTER.

9. Select FULL LEVEL.

Press ENTER.

10. Fill the tank.

Allow a few seconds for the sending unit to stabilize.

Press ENTER.

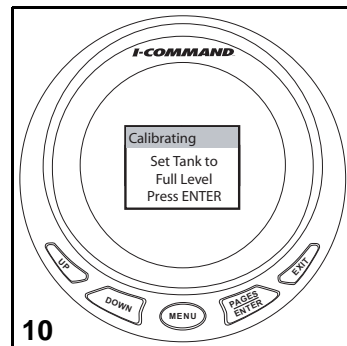
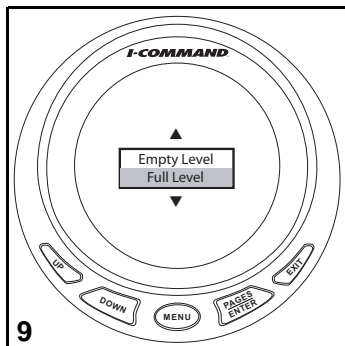
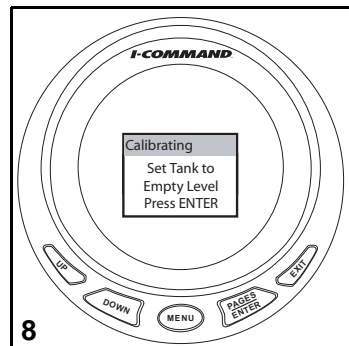
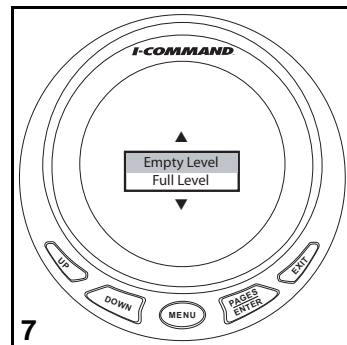

Fuel Management

Fuel Remaining Source

The *I-Command* gauge uses Fuel Remaining Source to determine the amount of fuel remaining. The default setting is FLUID LEV SNSR.

1. Press MENU. Use the UP or DOWN buttons to select SYSTEM SETUP. Press ENTER.
2. Use the UP or DOWN buttons to select FUEL SETUP. Press ENTER.
3. Use the UP or DOWN buttons to select FUEL REM SRC. Press ENTER.

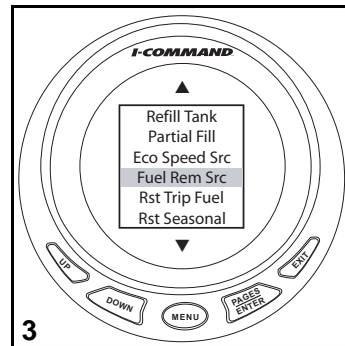
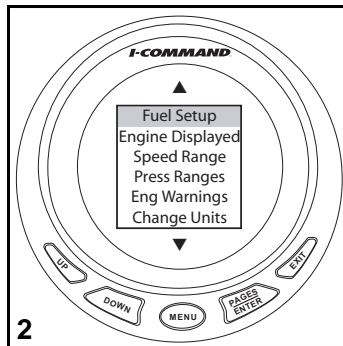
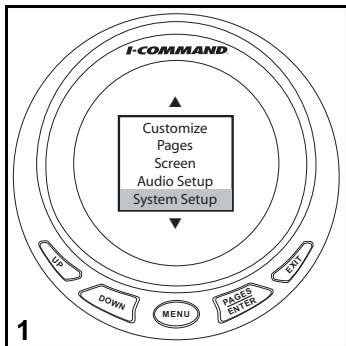

Use the UP or DOWN buttons to make selection. Review the following to determine which choice will work best in your application.

FLUID LEV SNSR (Fluid Level Sensor) -

4. Fluid level accuracy is dependent on sending unit accuracy, capacity entered during setup, and liquid level consumed from tank. Requires installation of a fluid level sensor. Use the FIVE POINT calibration (see “Fuel or Fluid Level Sensor Calibration” on page 63) to achieve the best accuracy.

ENG/FFLOW (Engine Fuel Flow) -

5. Uses the outboard’s *EMM* software to calculate fuel consumed and subtracts from fuel tank capacity entered during setup. Engine fuel flow requires installation of memory module kit.

A GPS antenna and memory module kit must be installed to track seasonal fuel, trip fuel, fuel range, and economy.

IMPORTANT: Fuel flow data from the *EMM* is required. User must enter amount of fuel added at each fill up (see “Refill Tank” on page 69) or perform the “Partial Fill” procedure (see “Partial Fill” on page 69). A GPS antenna must be installed for fuel management features to be functional.

Perform this procedure on each gauge.

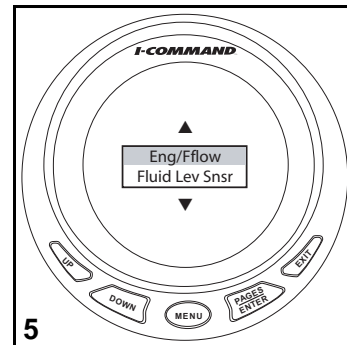
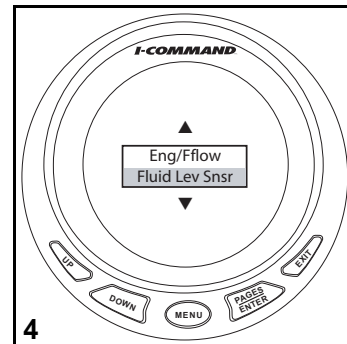

Fuel Management Options

Use the following steps to access fuel management options.

1. Press MENU.

Use UP or DOWN buttons to Select SYSTEM SETUP.

Press ENTER.

2. Use UP or DOWN buttons to select FUEL SETUP.

Press ENTER.

3. Use the UP or DOWN buttons to select REFILL TANK or PARTIAL FILL.

Press ENTER.

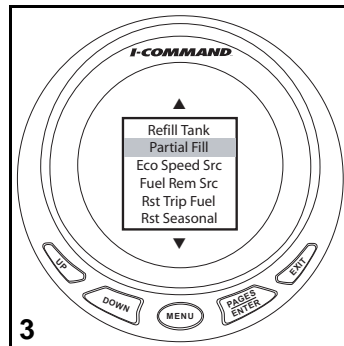
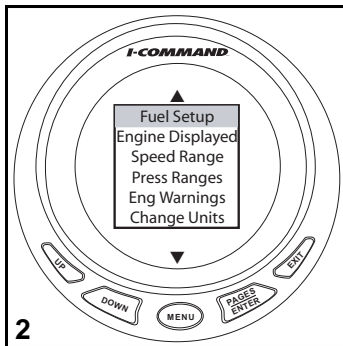
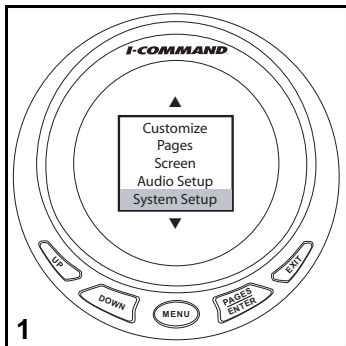

Refill Tank

1. Choose the Refill Tank option to recalibrate the fuel tank level after it has been filled to full capacity.

Press the ENTER button after fuel tank has been filled.

Note: Only supported when the memory module is used as the fuel remaining source.

Partial Fill

2. Choose the Partial Fill option to maintain the accuracy of the level by allowing the operator to input fuel added to the tank.

Use the UP button to enter the quantity of fuel added to the fuel tank.

Use the UP or DOWN button to make adjustments.

Press ENTER when finished.

Note: Only supported when the memory module is used as the fuel remaining source.

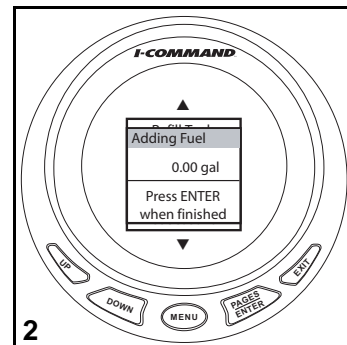
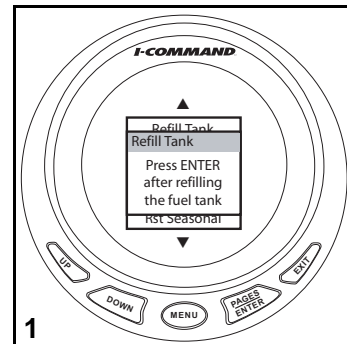

Economy Speed Source

The Economy Speed Source option sets the speed measurement source.

Press MENU.

Use UP or DOWN buttons to Select SYSTEM SETUP.

Press ENTER.

Use UP or DOWN buttons to select FUEL SETUP.

Press ENTER.

1. Use the UP or DOWN buttons to select ECO SPEED SRC.

Press ENTER.

2. Use UP or DOWN buttons to select:

- Water Speed (Paddle Wheel) works best for low speeds.
- Pitot Speed works best for high speeds.
- Ground Speed (GPS) works well for both high and low speeds.

Press ENTER when finished.

Reset Fuel Usage

Fuel usage can be tracked for trips and an entire season.

Press MENU.

Use UP or DOWN buttons to Select SYSTEM SETUP.

Press ENTER.

Use UP or DOWN buttons to select FUEL SETUP.

Press ENTER.

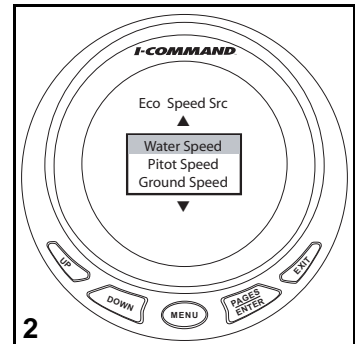
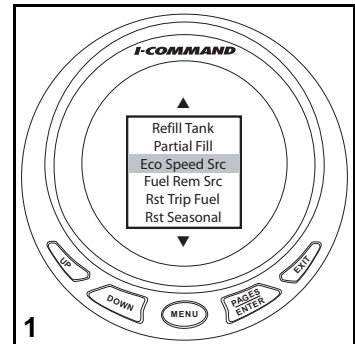

Use the following steps to reset fuel usage.

Reset Trip Fuel

1. Use the UP or DOWN buttons to select RESET TRIP FUEL.
Press ENTER to reset the trip fuel total to zero.

Reset Seasonal Fuel

2. Use the UP or DOWN buttons to select RESET TRIP FUEL.
Press ENTER to reset the seasonal fuel total to zero.

Note: For multi-engine applications, select the appropriate engine to reset, or select ALL ENGINES to simultaneously reset all engines.

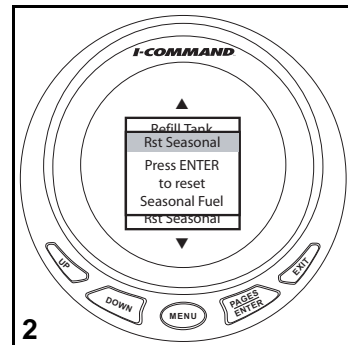
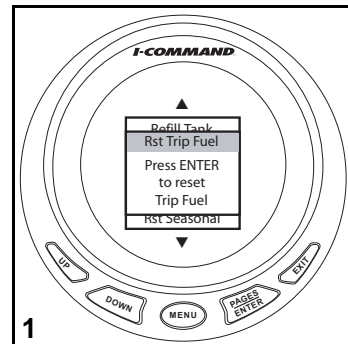

Configure Sensors

Follow these steps to add new unconfigured sensors to the network.

Temperature Sensor

1. Press MENU. Use the UP or DOWN buttons to select SYSTEM SETUP.
Press ENTER.
2. Use the UP or DOWN buttons to select BUS DEVICES.
Press ENTER.
3. The gauge will search for devices.

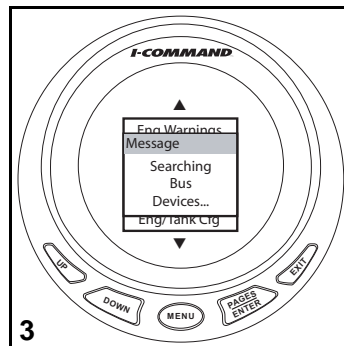
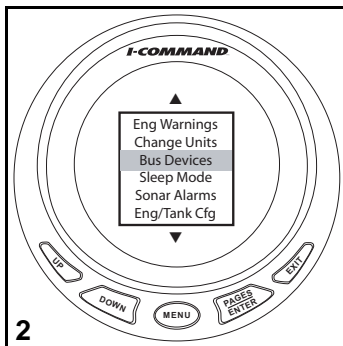
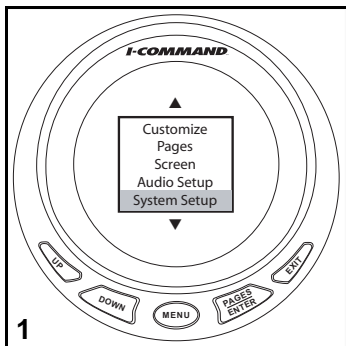

4. Use the UP or DOWN buttons to select UNCFG TEMP.
Press ENTER.
 5. Press ENTER to configure Temperature Sensor.
 6. Use the UP or DOWN buttons to make selection.
Press ENTER.
 7. The gauge will save the change the to the device and return to the BUS DEVICES list.
- Press EXIT three times to return to gauge display.

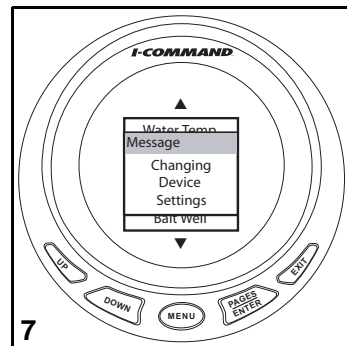
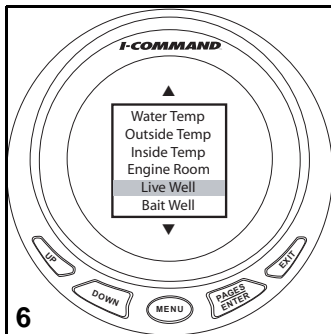
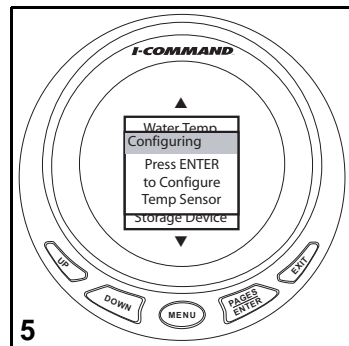
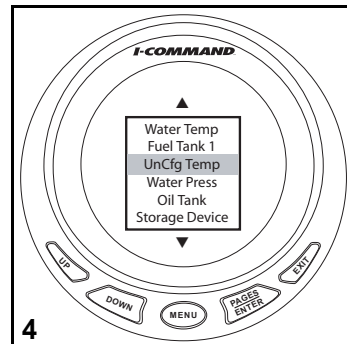

Configure Pressure Sensor

1. Press MENU. Use the UP or DOWN buttons to select SYSTEM SETUP.
Press ENTER.
2. Use the UP or DOWN buttons to select BUS DEVICES.
Press ENTER.
3. The gauge will search for devices.

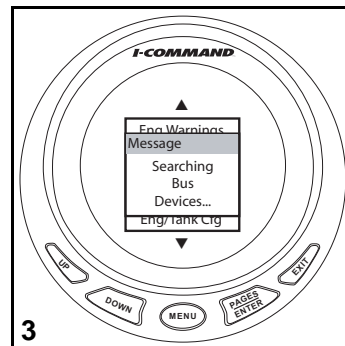
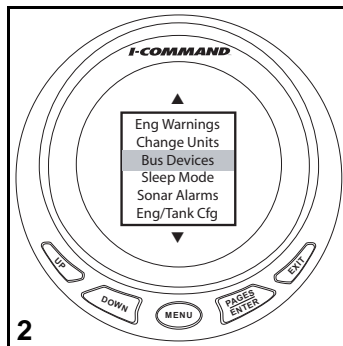
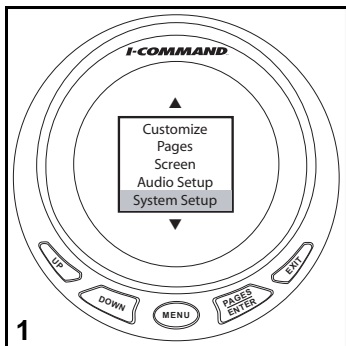

4. Use the UP or DOWN buttons to select UNCFG PRESS.
Press ENTER.
 5. Press ENTER to configure Pressure Sensor.
 6. Use the UP or DOWN buttons to make selection.
Press ENTER.
 7. The gauge will save the change the to the device and return to the BUS DEVICES list.
- Press EXIT three times to return to gauge display.

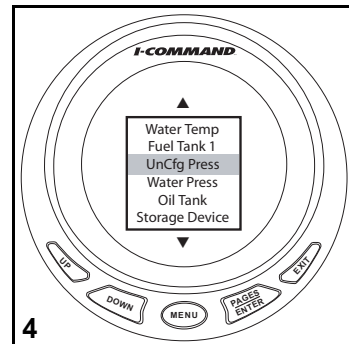

4

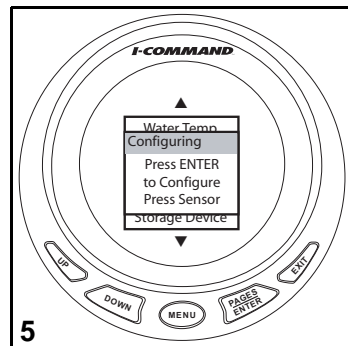

5

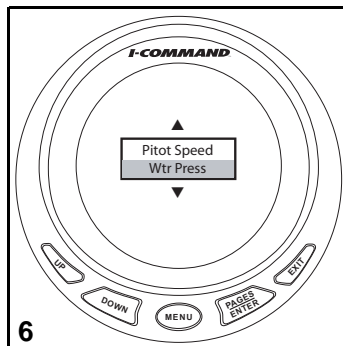

6

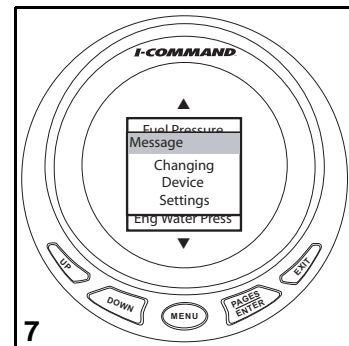

7

Change Ranges

This example will change the water pressure gauge to read from 0 – 60 psi, to 0 – 30 psi. Speed ranges and other pressure ranges can be changed in the same manner.

1. Press the ENTER or EXIT buttons repeatedly to scroll to the page to be changed.
2. Press MENU.
Use the UP or DOWN buttons to select SYSTEM SETUP.
Press ENTER.
3. Use the UP or DOWN buttons to select PRESS RANGES.
Press ENTER.

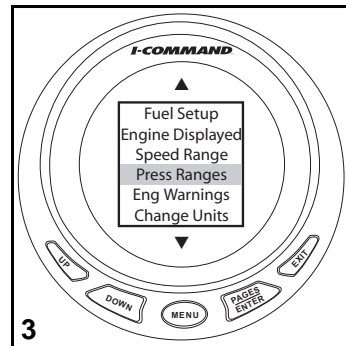
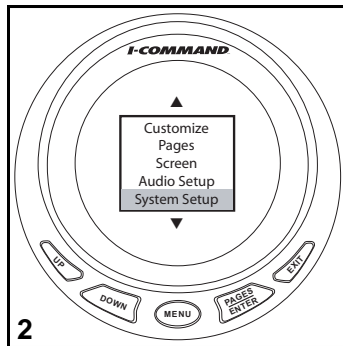
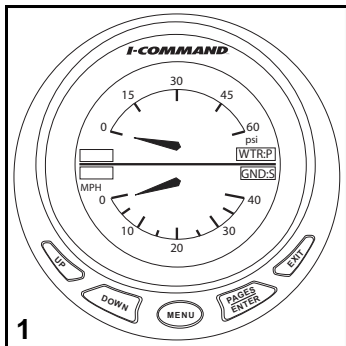

- Use the UP or DOWN buttons to select WATER PRESS.
Press ENTER.
- Use the UP or DOWN buttons to select desired pressure range.
Press ENTER.
- Gauge will now display selected range.

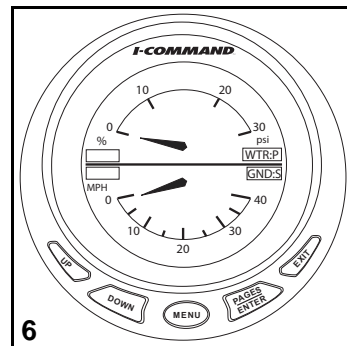
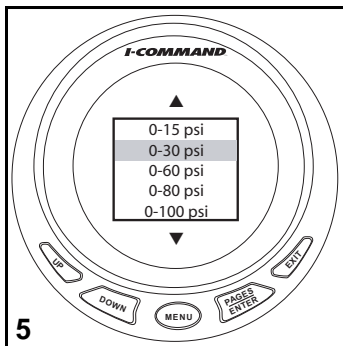
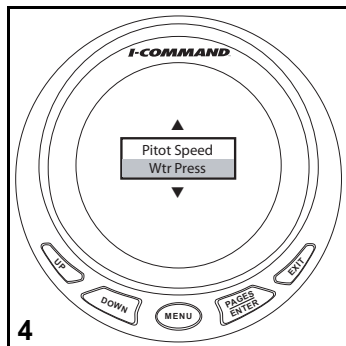

Winterize

The 3.5 inch *I-Command* digital gauge provides a winterize feature for 2008 and newer 115–300 HP V4/V6 *Evinrude E-TEC* outboard models.

The engine must be running to use this option. Refer to the Outboard Operator's Guide for complete storage procedures and Safety Precautions.

1. Press MENU. Use the UP or DOWN buttons to select SYSTEM SETUP.
Press ENTER.
2. Use the UP or DOWN buttons to select BUS DEVICES.
Press ENTER.
3. The gauge will search for devices.

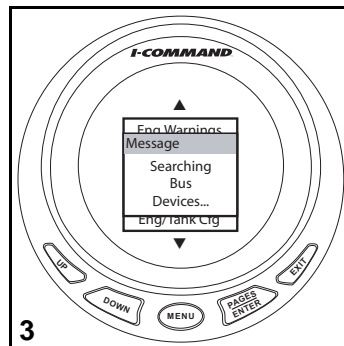
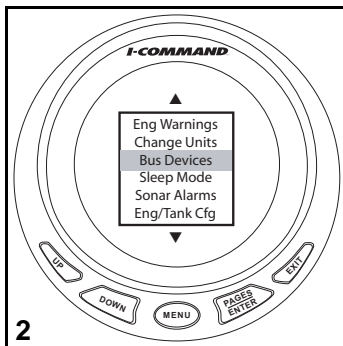
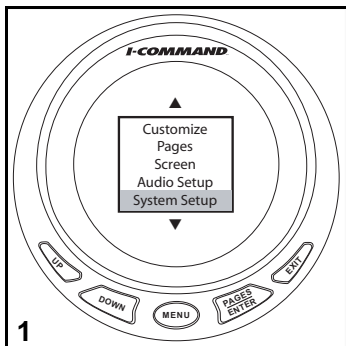

4. Use the UP or DOWN buttons to select engine to winterize.
Press ENTER.
5. The gauge will display WINTERIZE menu.
Press ENTER.
6. Press ENTER again.

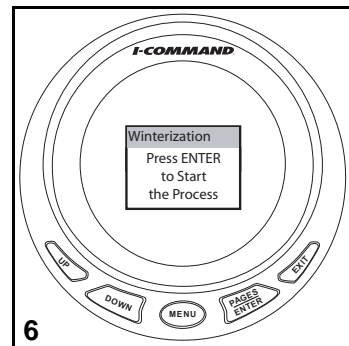
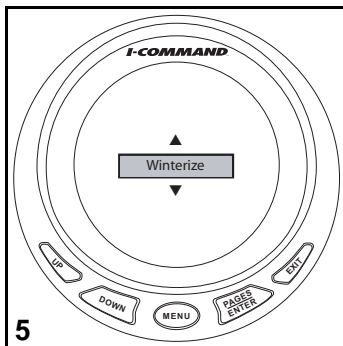
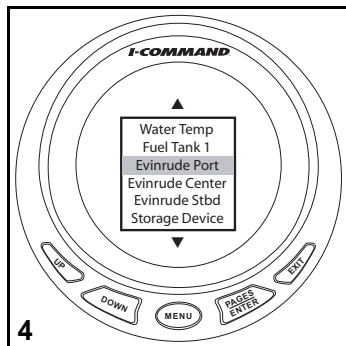

7. The gauge will display WINTERIZATION message.
8. When prompted, engage NEUTRAL only button on remote control and advance THROTTLE ONLY to at least 50%.
9. Gauge will display WINTERIZATION IN PROGRESS message.
10. When the winterization cycle is complete the engine will shut off and the gauge will display WINTERIZATION IS COMPLETE message.

Press EXIT to return to BUS DEVICES menu.

Repeat steps 4 through 10 for other engines (two through five engines only).

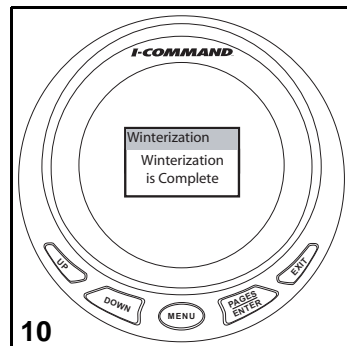
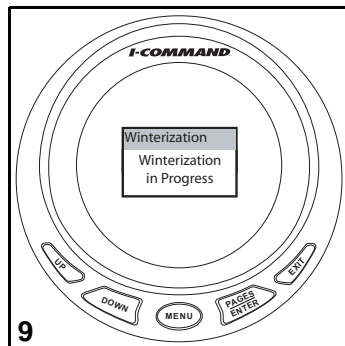
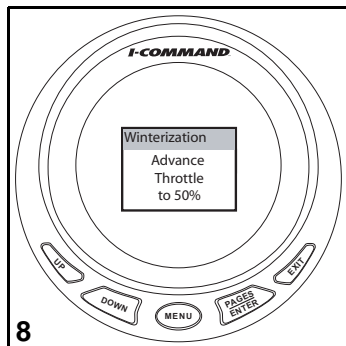
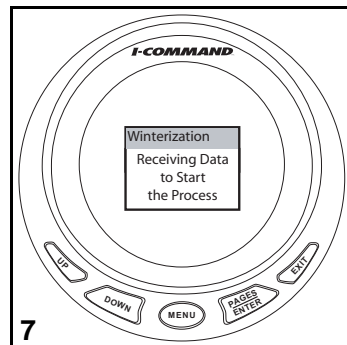

Audio Settings

Audio functions of the *I-Command* Digital gauge can be turned OFF or ON.

1. Press MENU.
Use the UP or DOWN buttons to select AUDIO SETUP.
Press ENTER.
2. Use the UP or DOWN buttons to select KEY SOUNDS.
Press ENTER.
3. Use the UP or DOWN buttons to select ON or OFF setting.
Press ENTER when finished.

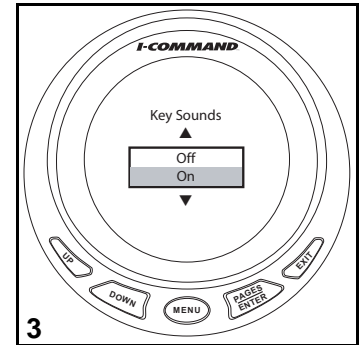
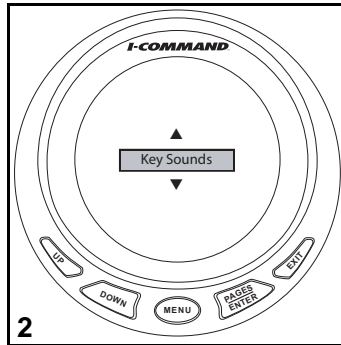
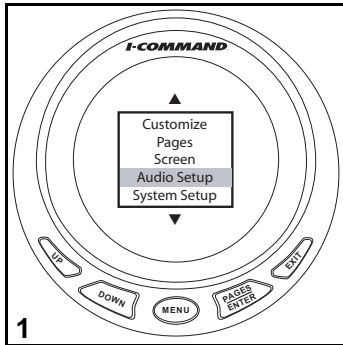

Reset Values

Use RESET VALUES to restore the gauge default settings. Reset Values will not clear sensor settings that were previously calibrated or configured.

1. Press MENU.
Use UP or DOWN buttons to select SYSTEM SETUP.
Press ENTER.
2. Use UP or DOWN buttons to select RESET VALUES.
Press ENTER.

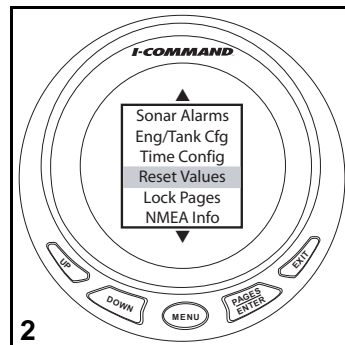
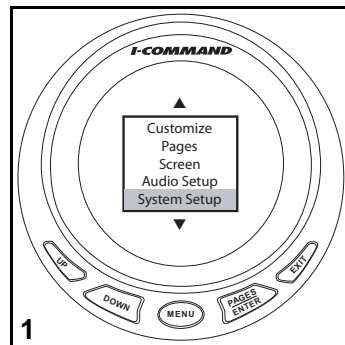

3. Use UP or DOWN buttons to select PAGES, SETTINGS or ALL.
Press ENTER.

- Select PAGES to reset the seven factory default pages. See “Information Displays” on page 22.
- Select SETTINGS to reset Fuel Remaining Source, Fuel Economy Speed Source, Keypad Sounds, Sleep Mode, Fluid Level Warnings, Sonar Alarms and Boat Set Up.
- Select ALL to reset both.

4. A confirmation message will appear.
Press ENTER to continue.

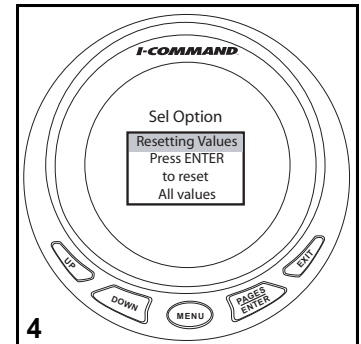
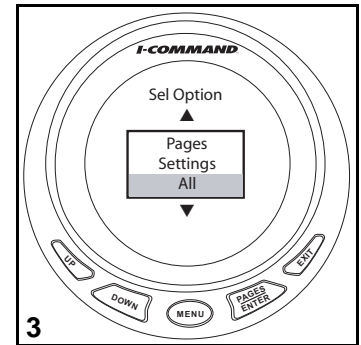

Sonar Alarms

Sonar alarms are available to aid in avoiding underwater objects or shallow operating conditions. A transducer or triducer is required for sonar alarm functionality.

This example will set the shallow sonar alarm.

1. Press MENU.
Use UP or DOWN buttons to select SYSTEM SETUP.
Press ENTER.
2. Use UP or DOWN buttons to select SONAR ALARMS.
Press ENTER.

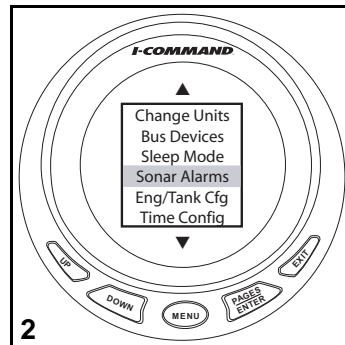
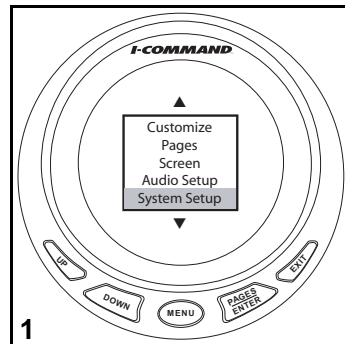

3. Use UP or DOWN buttons to select SHALLOW (or DEEP) alarm.
Press ENTER.
4. Use UP or DOWN buttons to select SET DEPTH (or OFF).
5. Use UP button to set depth. Use UP or DOWN buttons to make adjustments.
Press ENTER to save selection.

To set DEEP alarm, press EXIT one and go to Step 3.

To turn sonar alarms OFF, press EXIT and go to Step 4.

Press EXIT four times, when finished.

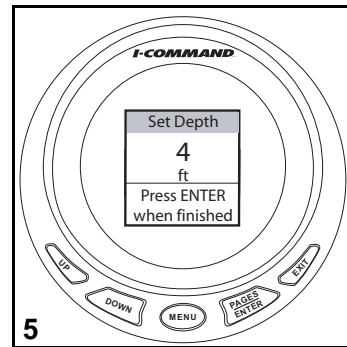
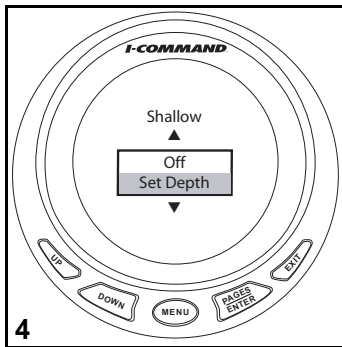
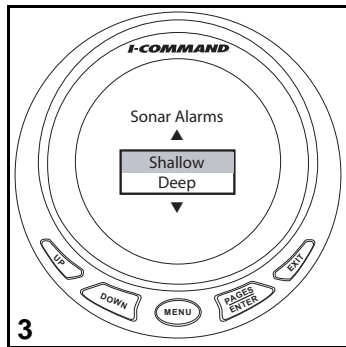

Troubleshooting

Troubleshooting Steps

Use a process of elimination to troubleshoot network problems.

1. If the *I-Command* digital display flashes four dashes (----) it indicates the gauge is not receiving signal from one or more devices.

- Make sure devices are configured. See “Advanced Operation” on page 59.
- If multiple displays are flashing, check common items such as cables and t-connectors.
- Remove components from the network **one at a time** to isolate which one may have failed.
- Look for damaged parts. Check connectors for corrosion.
- Swap known good components (sensor, cables or t-connectors) to isolate the faulty component.
- Reconnect the good component to the network and the remove the next one in line.
- Continue this process for each device, cable or tee connector on the network until the faulty part is found.

Note: After a component is reconnected to the network, turn power to the network OFF and back ON to reset the gauge(s).

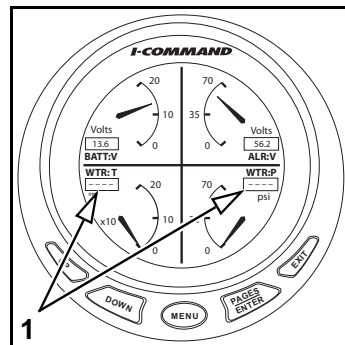

Engine Warnings

I-Command gauges monitor engine conditions and display warnings in the event of a malfunction. Refer to the outboard Operator's Guide if engine warnings are displayed.

WARNING MESSAGE DISPLAYED	POSSIBLE CAUSE	PROCEDURE
Check Engine	A "Check Engine" condition is activated when a critical engine condition occurs, or when a service is required.	<ul style="list-style-type: none"> · A "critical" condition activates <i>S.A.F.E.</i> (RPM reduction) - Seek assistance to return to safe harbor immediately and see your dealer. Continued operation in <i>S.A.F.E.</i> could result in an Engine Shut Down condition. · A minor service issue will NOT activate <i>S.A.F.E.</i> - See your dealer as soon as practical.
Over Temperature	Engine or <i>EMM</i> above temperature range.	Check cooling water to water intake screens.
Low Oil Level	A low oil level has been detected.	Fill oil tank.
Low System Voltage	A low voltage condition has been detected.	See dealer for service.
Throttle Position Sensor	A throttle position sensor fault has been detected.	
Rev Limit Exceeded	The RPM limit has been exceeded.	Reduce throttle.
Power Reduction	<i>EMM</i> has activated <i>S.A.F.E.</i>	See dealer for service immediately.
Engine Shutting Down	<i>EMM</i> has activated engine shutdown.	
Neutral Start Protection	Attempt to start engine while in gear.	Shift to neutral.

Evinrude E-TEC Engine Warnings

I-Command gauges monitor engine conditions and display warnings in the event of a malfunction. The following table lists warnings that are specific to *Evinrude E-TEC* models. Refer to the outboard Operator's Guide if engine warnings are displayed.

WARNING MESSAGE DISPLAYED	POSSIBLE CAUSE	PROCEDURE
Sensor malfunction see dealer	Throttle position sensor fault detected.	See dealer for service.
	Analog 5V supply overload detected.	
	Knock Sensor circuit fault detected.	
	Water Pressure Transducer fault detected.	
	Exhaust pressure circuit fault detected.	
Sensor malfunction service soon	Engine temperature sensor, Air temperature sensor, Oil pressure circuit or Water pressure circuit fault detected.	See dealer for service.
Water in Fuel, service soon	Water in fuel detected (115–300 HP models).	
Low battery voltage see manual	Battery voltage below expected range.	
RPM reductn activated see dealer	System Voltage below expected range.	See dealer for service immediately.
	System Voltage above expected range.	
	Excessive Engine Knock detected (200–300 HP 90° V6 models).	
Winterization Mode activated	Auto-winterization activated (115–300 HP models).	See "Winterize" on page 78.
Overheat RPM reductn activated see manual	EMM temperature above expected range.	See engine Operator's Guide.
Engine Over Temp Fault	Engine temperature above normal range.	

WARNING MESSAGE DISPLAYED	POSSIBLE CAUSE	PROCEDURE
Overheat RPM reductn chk water & manual	Engine temperature above range.	See engine Operator's Guide.
Overheat Eng Shutdwn see manual	Engine shutdown, EMM above max temperature.	
	Engine shutdown, engine above max temperature.	
No Oil Shutdwn see manual	Engine shutdown, excessive no oil fault.	Seek assistance to return to harbor, see dealer immediately.
No Oil RPM reductn check oil	Oil solenoid open circuit.	
No Oil RPM reductn see dealer	Oil pressure pulses in manifold not detected.	
No Oil RPM reductn see dealer	Oil system prime failure.	
Engine Shutdown see dealer	Possible fuel leak.	
RPM reductn activated, ICON fault	–	See <i>ICON</i> Remote Control User's Guide.
Injector malfunction see dealer	Fuel injector open or short circuit detected.	See dealer for service immediately.
Solenoid malfunction see dealer	Starter solenoid circuit open-circuit (115–300 HP models).	
	Water injection solenoid open circuit (60–65 HP models).	
Ignition malfunction see dealer	Ignition primary open circuit detected.	
Fuel pump malfunction see dealer	Fuel pump open circuit detected.	
Power valve malfunction see dealer	Exhaust valve solenoid open circuit (115–130 HP models).	

Network Troubleshooting Chart

OBSERVATION	POSSIBLE CAUSE	PROCEDURE
<i>I-Command</i> gauge screen is dark. Gauge does not turn ON.	<i>I-Command</i> gauge is not connected to the network.	Check connection.
	Power supply cable 3A fuse is failed.	Check fuse, replace as needed.
	The tee connector that the gauge is plugged into has failed.	Inspect tee connector for damage. Swap known good tee connector.
	The power supply cable is not connected to the Ignition and Trim/Tilt harness.	Check connection.
<i>I-Command</i> gauge screen is dark. Gauge does not turn ON. 3A fuse repeatedly fails.	Network current draw is exceeding 3A.	Check all connections and wiring. Disconnect accessory connections to network. See "Troubleshooting Steps" on page 88.
<i>I-Command</i> instrument display is erratic.	Terminators not installed.	Check terminator installation. Check network buss cable and device connections. See "Terminating Resistors" on page 11.
No "Fuel Manager".	Requires memory module and setup of the <i>I-Command</i> display.	See "Fuel Management" on page 66.
No "Fuel Economy" display for Fuel Manager.	No signal from <i>NMEA 2000</i> GPS receiver.	See "Fuel Manager" on page 32.
Four dashes "----" displayed on LCD (Engine related functions).	<i>EMM</i> harness is not connected.	Check connections at <i>EMM</i> and t-connector.
	<i>EMM</i> harness is damaged.	Inspect <i>EMM</i> harness for damage. Swap known good <i>EMM</i> harness.
	The tee connector that the <i>EMM</i> harness is plugged into has failed.	Inspect tee connector for damage. Swap known good tee connector.
	Engine position incorrectly set.	Use <i>Evinrude Diagnostics</i> software to check/ set outboard position.

OBSERVATION	POSSIBLE CAUSE	PROCEDURE
Invalid Fluid Level message displayed on gauge.	Vessel fuel capacity and fuel tank capacity do not match.	The capacity of each fuel tank must be entered during set up. See "Configure Fuel Tank Capacity" on page 19.
Configuration Mismatch Error message displayed on gauge. Occurs when a device is replaced.	Configuration of device does not match Boat Setup.	Configure device to match Boat Setup.
<p>Four dashes "----" displayed on LCD (Sensor related functions):</p> <ul style="list-style-type: none"> • No speed display. • Speed-Over-Ground (SOG) does not display. • Speed-Over-Water (SOW) does not display. • Water depth does not display. • Temperature does not display. • Fluid level (Fuel, Oil or other) does not display. • Engine water pressure does not display. 	<p>No signal from <i>NMEA 2000</i> device:</p> <ul style="list-style-type: none"> • No signal from speed transducer or GPS receiver. • No signal from GPS receiver. • No signal from speed transducer. • No signal from depth transducer. • No signal from temperature transducer. • No signal from fluid level sensor. • No signal from water pressure transducer. 	<p>Check that the device is installed and connected to the network.</p> <p>Use the "Bus Devices" menu to confirm the device is communicating on the network. See "Troubleshooting Steps" on page 88.</p> <p>See "Configure Fluid Level Sensor" on page 60. See "Fuel or Fluid Level Sensor Calibration" on page 63.</p> <p>See "Configure Pressure Sensor" on page 74. Use <i>Evinrude Diagnostics</i> Software to set water pressure option. See "Engine Options" on page 13.</p>
Water pressure related fault codes observed after initial setup.	Water pressure transducer not connected.	Check water pressure transducer connections.
<p>Note: <i>I-Command</i> devices must be connected to the "DEVICE" connector (center) of the t-connector. Check condition of all t-connectors. Inspect pins and sockets of t-connectors and device connectors carefully. Damaged or shorted connectors can damage 3 amp fuse.</p>		

Reference

Abbreviation Tables

Use the abbreviation tables to interpret information from the *I-Command* gauge.

Abbreviation	Function
AIR:T	Air Temperature
ALR:V	Alternator voltage
ATM:P	Atmospheric Pressure
BAT:C	Battery current
BAT:T	Battery Temperature
BAT:V	Battery voltage
BKW:L:1	Black Water Tank 1
BKW:L:#	Black Water Tank #
WTR:P	Coolant Pressure
CYL:T	Cylinder Temperature
DPT	Depth
ENG:L	Engine Load
ENG:T	Engine Temperature
ENG:TQ	Engine Torque
ENG:TM	Engine Trim
ENG:W:T	Engine Water Temperature
FRW:L	Fresh Water Level
FRW:CP	Fresh Water Capacity

Abbreviation	Function
FRW:L:#	Fresh Water Tank #
FUL:CP	Fuel Capacity
FUL:E	Fuel Economy
FUL:W:E	Water Fuel Economy
FUL:G:E	GPS Fuel Economy
FUL:F:C	Fuel Flow Center
FUL:F:P	Fuel Flow Port
FUL:F:S	Fuel Flow Starboard
FUL:F:#	Fuel Flow Engine #
FUL:L	Fuel Level
FUL:RG	Fuel Range
FUL:W:RG	Water Fuel Range
FUL:G:RG	GPS Fuel Range
FUL:RM	Fuel Remaining
FUL:RM:C	Fuel Remaining Center
FUL:RM:P	Fuel Remaining Port
FUL:RM:S	Fuel Remaining Starboard
FUL:RM:#	Fuel Remaining Tank #

Abbreviation	Function
FRW:L:1	Fresh Water Tank 1
FRW:L:#	Fresh Water Tank #
FUL:L:S	Fuel Tank Starboard
FUL:U	Fuel Used
FUL:U:C	Fuel Used Center
FUL:U:P	Fuel Used Port
FUL:U:S	Fuel Used Starboard
FUL:U:#	Fuel Used Engine #
GPS:S	GPS speed
IND:T	Inside Temperature
INT:T	Intake Air Temperature
LVW:L	Live Well Level
LVW:CP	Live Well Capacity
LVW:L:1	Live Well Tank 1
LVW:L:#	Live Well Tank #
OIL:CP	Oil Capacity
OIL:P	Oil Pressure
OIL:L	Oil Level
OIL:L:C	Oil Tank Center
OIL:L:P	Oil Tank Port
OIL:L:S	Oil Tank Starboard

Abbreviation	Function
FUL:L:C	Fuel Tank Center
FUL:L:P	Fuel Tank Port
OUT:T	Outside Temperature
PWD:S	Paddlewheel speed
PTT:S	Pitot speed
RPM:RT	Rated RPM
FUL:U:S	Seasonal Fuel Used
BKW:L	Sewage Level
BKW:CP	Sewage Capacity
RPM	Tachometer
ENG:T:H	Total Engine Hours
TTB	Trim Tabs
FUL:U:TP	Trip Fuel Used
FLD:L	Unknown Fluid Level
FLD:CP	Unknown Fluid Capacity
WST:L	Waste Water Level
WST:CP	Waste Water Capacity
WST:L:1	Waste Water Tank 1
WST:L:#	Waste Water Tank #
WTR:T	Water Temperature

Abbreviations Key

The *I-Command* gauge displays data from network connected *NMEA 2000* devices as follows:

- Display Category : Category Type : Modifier : Location /Instance
- An example might be: FUL : RM : P, is fuel remaining, port tank.

Display category and an instance/location should always appear. Depending on the device one or both category type or modifier may or may not appear.

Display Category	Abbreviation	Category Type / Modifier	Abbreviation	Location /Instance	Abbreviation
Air	AIR	Absolute	A	Port	P
Alternator	ALR	Capacity	CP	Port – Center	P–C
Altitude	ALD	Current	CU	Center	C
Atmospheric	ATM	Economy	E	Starboard – Center	S–C
Battery	BAT	Flow	F	Starboard	S
Black Water	BKW	GPS	G	Vessel	V
Boost	BST	Ground	G	1	1
Coolant	WTR	Hours	H	2	2
Cylinder	CYL	Level	L	3	3
Depth	DPT	Load	L	4	4
Economy	ECO	Oil	O	5	5
Engine	ENG	Pressure	P	6	6

System Information

Use the following steps to view the *I-Command* gauge software information.

Press MENU.

1. Use the UP or DOWN buttons to select SYSTEM SETUP.
Press ENTER.
2. Use the UP or DOWN buttons to select SYSTEM INFO.
Press ENTER.
3. The system info is now displayed.

Press EXIT to return to Main display.

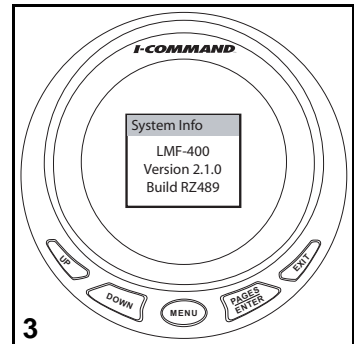
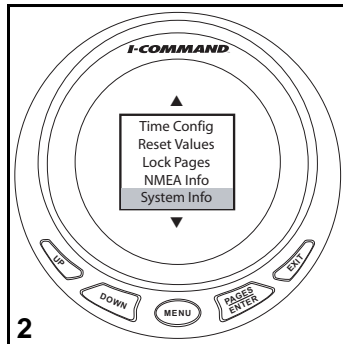
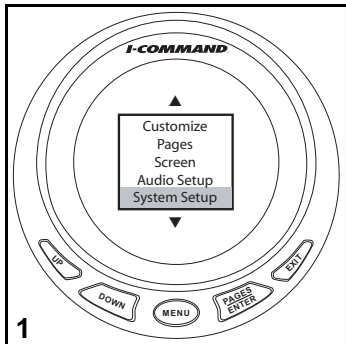

Product Warranty

Warranty Statement

BRP US INC. LIMITED WARRANTY FOR 2010 EVINRUDE/JOHNSON GENUINE PARTS AND ACCESSORIES SOLD IN THE UNITED STATES AND CANADA

BRP US Inc.* ("BRP") warrants its *Evinrude®/Johnson® Genuine Parts* and accessories ("Product") sold by authorized *Evinrude* or *Johnson* dealers in the fifty United States and Canada from defects in material or workmanship for the period and under the conditions described below. This limited warranty does not apply to Products not bearing the *Evinrude* or *Johnson* trademarks that are made by other manufacturers. This limited warranty extends to the original retail purchaser only ("Purchaser") and is not transferable to any subsequent owner. This warranty is available only on Products purchased as new and unused from a dealer authorized to distribute the Products in the country in which the sale occurred ("Dealer").

Aluminum propellers, plastic propellers, stainless steel propellers, *Snap-In™* control cables and *DuraTank™* fuel tanks are warranted for THIRTY SIX (36) CONSECUTIVE MONTHS from the date of purchase as of July 1, 2006.

ICON™ engine control systems and components are warranted for THIRTY SIX (36) CONSECUTIVE MONTHS from the date of purchase for recreational use or TWELVE (12) CONSECUTIVE MONTHS for commercial use.

Powerhead assemblies are warranted for a period of SIX (6) CONSECUTIVE MONTHS from the date of purchase. All other Products are warranted for a period of TWELVE (12) CONSECUTIVE MONTHS from the date of purchase.

The following are not warranted under any circumstances: (a) normal wear and tear; (b) routine maintenance items including, but not limited to, adjustments, oil changes, water pumps, carburetor maintenance,

spark plug replacements, etc.; (c) cosmetic damage or paint changes due to exposure to the elements; or (d) damage caused by: improper or lack of installation, maintenance, winterization and/or storage; failure to follow the procedures and recommendations in the Operator's Guide; removal of parts, improper repairs, service, maintenance, or modification; use of parts or accessories not manufactured or approved by BRP that are either incompatible with Product or adversely affect its operation, performance, or durability; repairs done by anyone, including Purchaser, other than an authorized Dealer; abuse, misuse, abnormal use, neglect, racing, improper operation or operation of Product in a manner inconsistent with the Operator's Guide; external damage, accident, submersion, water ingestion, fire, theft, vandalism or act of God; operation with fuels, oils or lubricants not suitable for use with Product (see Operator's Guide); rust or corrosion; or cooling system blockage by foreign material.

This warranty will be **voided in its entirety and rendered null and void:** (a) where Product has been altered or modified in such a way so as to adversely affect its operation, performance or durability, or has been altered or modified to change its intended use; or (b) where Product is or has been used for racing or any other competitive activity, at any point.

ALL WARRANTIES, EXPRESSED OR IMPLIED, INCLUDING WITHOUT LIMITATION ANY WARRANTY OF MERCHANTABILITY OR FITNESS FOR A PARTICULAR PURPOSE ARE LIMITED IN DURATION TO THE LIFE OF THIS EXPRESS LIMITED WARRANTY. ALL INCIDENTAL, CONSEQUENTIAL, DIRECT, INDIRECT OR OTHER DAMAGES OF ANY KIND ARE EXCLUDED FROM COVERAGE UNDER THIS WARRANTY INCLUDING, BUT NOT LIMITED TO: expense for gasoline, expense for transporting Product to and from Dealer, removal of Product from a boat and reinstallation, mechanic's travel time, in-and-out of water charges, slip or dock fees, trailering or towing, storage, telephone, cell phone, fax or telegram charges, rental of a like or replacement Product or boat during warranty services or down time, taxi, travel, lodging, loss of or damage to personal property, inconvenience, cost of insurance coverage, loan payments, loss of time, income, revenue, profits, enjoyment or use of Product.

SOME JURISDICTIONS DO NOT ALLOW FOR THE DISCLAIMERS, LIMITATIONS OF INCIDENTAL OR CONSEQUENTIAL DAMAGES, OR OTHER EXCLUSIONS IDENTIFIED ABOVE. AS A RESULT, THEY MAY NOT APPLY TO YOU. THIS WARRANTY GIVES YOU SPECIFIC RIGHTS, AND YOU MAY ALSO HAVE OTHER LEGAL RIGHTS THAT MAY VARY FROM JURISDICTION TO JURISDICTION.

Purchaser must bring the Product, including any defective part therein, and proof of purchase of the Product (original bill of sale) to Dealer promptly after the appearance of the defect and, in any event, within the warranty period. Purchaser must sign the repair/work order prior to repair to validate warranty coverage and must provide BRP/Dealer with a reasonable opportunity to repair/replace the defective part. All replaced parts become the property of BRP.

BRP's obligations under this warranty are limited to, at its sole discretion, repairing or replacing parts of Product found to be defective in material or workmanship, in BRP's reasonable judgment. Repair or replacement of parts will be without charge for parts and labor, at any authorized Dealer. No claim of breach of warranty shall be cause for cancellation or rescission of the sale of Product to Purchaser. BRP reserves the right to improve, modify or change Products without assuming any obligation to modify Products previously manufactured. If warranty service is required outside of the fifty United States or Canada, Purchaser will bear responsibility for any additional charges due to local practices and conditions including, but not limited to, freight, insurance, taxes, license fees, import duties, and any financial charges levied by governments, states, territories and agencies.

No distributor, Dealer or any other person is authorized to make any affirmation, representation or warranty regarding Product other than those contained in this limited warranty and, if made, shall not be enforceable against BRP. BRP reserves the right to modify this warranty at any time, being understood that such modification will not alter the warranty conditions applicable to the Products sold while this warranty is in effect. For assistance, please contact BRP US Inc. Consumer Support, P.O. Box 597, 10101 Science Drive, Sturtevant, WI 53177, 1-847-689-7090 or visit www.brp.com.

The Limited Warranty applies only to Products purchased as new and unused from a distributor or dealer authorized to distribute Products in the country in which the sale occurred.

Products purchased for commercial use, or used commercially at any time during the warranty period, are warranted for TWELVE (12) CONSECUTIVE MONTHS from the date of purchase. Product is used commercially when it is used in connection with any work or employment that generates income, during any part of the warranty period. Product is also used commercially when, at any point during the warranty period, it is installed on a boat that has commercial tags or is licensed for commercial use.

If warranty service is required outside of the country of original sale, Purchaser bears responsibility for any and all charges due to local practices and conditions that exceed or are in addition to customary charges in the country of sale, such as, but not limited to, freight, insurance, taxes, license fees, import duties, and any financial charges levied by governments, states, territories and agencies.

For assistance, please contact BRP US Inc. Consumer Support, P.O. Box 597, 10101 Science Drive, Sturtevant, WI 53177, 1-847-689-7090, or the affiliate of BRP Inc. where the Product was sold to the retail Purchaser.

No other change to the Limited Warranty shall be made or implied.

Effective as of July 1, 2009.

* In Canada, products are distributed and serviced by Bombardier Recreational Products Inc.

® Registered trademark of Bombardier Recreational Products Inc. or its affiliates.

© 2010 BRP US Inc. All rights reserved.

