

SEA-DOO®

Sport Boats

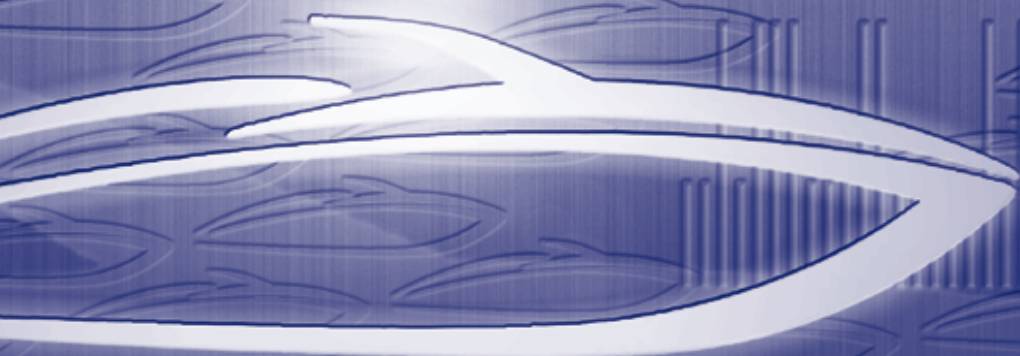

OPERATOR'S GUIDE

UTOPIA



WARNING

Read this guide thoroughly.
It contains important safety information.

2 1 9 0 0 0 2 5 2



SAFETY WARNING

Disregarding any of the safety precautions and instructions contained in this *Operator's Guide*, the *Safety Handbook*, the *Safety Videocassette* and the on-product warning labels could cause injury, including the possibility of death. The operator has the responsibility to inform passenger(s) of safety precautions.

This *Operator's Guide*, the *Safety Handbook* and *Safety Videocassette* should remain with the craft at the time of resale.

BOMBARDIER
RECREATIONAL PRODUCTS



Gelcote[†] is a trademark of Gelcote International
Knight's Spray-Nine[†] is a trademark of Korkay System Ltd

The following trademarks are the property of Bombardier Inc. and/or its subsidiaries:

SEA-DOO®
BOMBARDIER-ROTAX®
BOMBARDIER LUBE®
Sea-Doo Synthetic Grease

Doin'it on your new Sea-Doo Sport Boat

Congratulations, you are now the proud owner of a Sea-Doo sport boat. Whether you are an experienced boater or are new to the sport of boating, we ask you to take the time to view the videocassette provided with the craft, to read this *Operator's Guide*, the *Safety Handbook* and on-product warning/caution labels and familiarize yourself with the contents. These manuals contain pertinent information which, if followed, will provide you with the necessary knowledge to help you fully enjoy the pleasures of this craft.

We strongly recommend that any craft operator complete a safety boating course. Check with your local Coast Guard or Power and Sail Squadron in your area for course availability. More serious boaters may want to obtain *Chapman Piloting* by Elbert S. Maloney, available at most book stores.

When introducing your family or friends to the sport, be sure they fully understand the controls and operation of the craft and the importance of courteous, responsible riding.

Each operator has a responsibility to ensure the safety of his/her passenger(s) and of other water users. Please follow all safety instructions and operate your craft with care.

We encourage you to have an Annual Safety Inspection of your craft. Please contact your authorized Sea-Doo dealer for further details.

Finally, we urge you to visit your authorized Sea-Doo dealer regularly for regular and safety maintenance as well as any craft accessories you may require.

Have fun and... Bon Voyage.

Please keep this guide and *Safety Handbook* on board. These manuals should remain with the craft at time of resale.

TABLE OF CONTENTS

FOREWORD	5
△ SAFETY MEASURES	6
General	6
Operation.....	6
Maintenance.....	7
LIST OF DISTRIBUTORS	8
BOMBARDIER LIMITED WARRANTY NORTH AMERICA: SEA-DOO® SPORT BOAT	9
BOMBARDIER INTERNATIONAL LIMITED WARRANTY: SEA-DOO® SPORT BOAT	11
REGISTRATION NUMBER LOCATION	13
LOCATION OF THE IMPORTANT LABELS	14
IDENTIFICATION NUMBERS	18
Hull	18
Engine	18
CONTROLS, COMPONENTS AND INSTRUMENTS LOCATION	19
Cockpit	19
Overview	20
CONTROLS, COMPONENTS AND INSTRUMENTS FUNCTIONS.....	23
1) Safety Lanyard (engine cut-out switch)	23
2) Steering Wheel	23
3) Throttle/Shift Lever	23
4) Ignition Switch	24
5) 12-Volt Accessory Jack	24
6) Navigation Light Switch.....	24
7) Bilge Pump Switch	25
8) Bilge Air Blower Switch.....	25
9) Horn Switch	26
10) Deck Light Switch.....	26
11) Fuel Gauge/Low Oil Level Pilot Lamp and Beeper	26
12) Tachometer.....	27
13) Speedometer	27
14) Windshield.....	27
15) Bilge Drain Plugs.....	27
16) Grab Handles	28
17) Rear Grab Handles.....	28
18) Swim Platform	28
19) Sun Deck	28
20) Seats.....	28
21) Bow Seats (if so equipped).....	29
22) Cup Holders	29
23) Rear Seat Storage Compartment.....	29
24) Rear Storage Compartment.....	30
25) Bimini Top.....	30

26) Side Panel/Tray Storage	32
27) Bow Anchor Locker	32
28) Cockpit Table.....	32
29) Jet Pump Water Intake.....	33
30) Bow and Stern Eyelets	34
31) Bow Light	34
32) Removable Stern Light	34
33) Mooring Cleats	35
34) Deck	35
35) Fuel Tank Cap	35
36) Deck Drain(s)	35
37) Main Oil Reservoir Cap.....	36
38) Flushing Connector.....	36
39) Ventilation Ducts	36
40) Jet Pump Nozzle.....	36
41) Reverse Gate	36
42) Retractable Ladder	37
43) Hydro-Surge Grate System.....	37
44) Fuel Tank Vent.....	37
45) Fuses	37
46) Radio/CD Player.....	38
47) Glove Box	38
48) Water Bypass System.....	38
49) Main Battery Cut-Off Switch	38
50) Ski Tow	39
FUEL AND LUBRICATION	40
Fueling Procedure	40
Recommended Fuel.....	40
Recommended Oil	41
Main Oil Reservoir Level.....	41
Engine Mounted Oil Reservoir Level	41
BREAK-IN PERIOD	42
Engine	42
10-Hour Inspection.....	42
PRE-OPERATION CHECKS	43
Hull	44
Jet Pump Water Intake	44
Bilge	44
Battery.....	44
Fuel Tank/Oil Reservoirs	44
Engine Compartment	44
Fire Extinguisher	44
Steering System.....	44
Throttle/Shifter System	44
Inlet Grate	44
Safety Lanyard and Ignition Switch.....	45
Storage Compartment Covers	45

OPERATING INSTRUCTIONS	46
Launching/Loading	46
Trailing	46
Principle of Operation	46
Boarding from a Dock	48
Boarding from the Water	49
Starting	50
Rough Water or Poor Visibility Operation	50
Crossing Waves	50
Stopping/Docking	50
Beaching	51
Shutting Off the Engine	51
POST-OPERATION CARE	52
General Care	52
Additional Care for Foul Water or Salt Water	52
SPECIAL PROCEDURE	53
Engine Overheating	53
Jet Pump Water Intake and Impeller Cleaning	53
Capsized Boat	53
Submerged Boat	53
Low-Charge Battery Condition	54
MAINTENANCE	55
Lubrication	55
Periodic Inspection	55
Periodic Inspection Chart	56
Throttle/Shift Lever Cable	57
Fuel and Oil Filters	57
Steering/Jet Pump Nozzle Adjustment	57
Reverse Gate	57
Deck Drain(s)	57
Fuses	57
Bilge Air Blower	57
Navigation Light Bulb Replacement	58
General Inspection and Cleaning	59
STORAGE AND PRE-SEASON PREPARATION	60
Storage	60
Pre-Season Preparation	61
SPECIFICATIONS	62
SI METRIC INFORMATION	64
Homologation and Certification	66
Operator's Guide Confirmation of Receipt	67
PRIVACY INFORMATION	68
CHANGE OF ADDRESS	69

FOREWORD

The *Operator's Guide* and *Safety Handbook* have been prepared to acquaint the owner/operator or passenger with this personal craft and its various controls, maintenance and safe riding instructions. Each is indispensable for the proper use of the product, and should be kept in a waterproof bag with the craft at all times. Make sure you read and understand the content of each document.

For any questions pertaining to the warranty and its application, consult the WARRANTY section in this guide, and/or an authorized SEA-DOO sport boat dealer.

The information contained in this guide should always be used in conjunction with the information included in *Mercury Marine (M²) Jet Drive Operator's Guide*.

This guide uses the following symbols to emphasize particular information.

WARNING

Indicates a potentially hazardous situation which, if not avoided, could result in death or serious injury.

CAUTION

Indicates a potentially hazardous situation which, if not avoided, may result in minor or moderate injury. When used without the safety alert symbol , potential hazard exists for property damage only.

NOTE: Indicates supplementary information needed to fully complete an instruction.

Although the mere reading of such information does not eliminate the hazard, the understanding and application of the information will promote its correct use.

The information and components/system descriptions contained in this guide are correct at the time of publication. Bombardier Motor Corporation of America (B.M.C.A.) however, maintains a policy of continuous improvement of its products without imposing upon itself any obligation to install them on products previously manufactured.

Because of our ongoing commitment to product quality and innovation, Bombardier reserves the right at any time to discontinue or change specifications, designs, features, models or equipment without incurring obligation.

The illustrations in this document show the typical construction of the different assemblies and may not represent the full detail or exact shape of the parts. However, they represent parts that have the same or similar function.

It is understood that this guide may be translated into another language. In the event of any discrepancy, the English version shall prevail.

Specifications are given in the SI metric system with the SAE U.S. equivalent in parenthesis. Where precise accuracy is not required, some conversions are rounded off for easier use.

A SEA-DOO sport boat *Shop Manual* can be obtained for complete service, maintenance and more repair information.

⚠ SAFETY MEASURES

General

⚠ To fully appreciate the pleasures, enjoyment and excitement of boating there are some basic rules that should be observed and followed by any boater. Some rules may be new to you or covered in the PWC/Sport boat *Safety Handbook* or *Safety Video*, others may be common sense or obvious... irrespective, we ask that you please take a few minutes of your time to completely read these safety instructions before you operate your craft. **Failure to follow this safety information and safe boating rules could result in injury, including the possibility of death to you, your passenger(s), or other water users.**

⚠ Become completely familiar with the controls and operation of the craft before embarking on your first trip or taking on a passenger(s). If you have not had the opportunity to do so with your dealer, practice driving solo in a suitable area and feel the response of each control. Be fully familiar with all controls before applying the throttle above idle speed. As its operator, you control and are responsible for the craft's safe operation.

Operation

⚠ Always perform the pre-operation checks as specified in this guide.

⚠ Always keep in mind that as the throttle lever is released to idle position, less directional control is available and that directional control is lost when engine is off. **To turn the craft, both steering and throttle are necessary.**

⚠ Like any other boats, this craft has no brake. Stopping distance will vary depending on initial speed, load, wind, and water conditions. Practice stopping and docking in a safe, traffic free area to have an idea of how long it will take to stop the craft under varying conditions. Do not release throttle when trying to steer away from objects. You need throttle to steer. Do not use the craft's reverse, if so equipped, to stop.

⚠ Ensure that all passengers know how to swim and how to reboard the craft from the water.

⚠ The operator and passenger(s) should be properly seated and wearing a coast guard approved personal flotation device (PFD) or make sure that a coast guard approved PFD of appropriate size for each person is on board before starting or moving the craft and at all times when craft is in motion.

⚠ **Do not** start or operate the craft if a person(s) is seated on the sun deck or swim platform, or are nearby in the water.

⚠ The craft's jet thrust can cause injury. Always accelerate slowly.

⚠ To prevent accidental starting or unauthorized use, always detach the safety lanyard from the craft especially when swimmers are boarding or nearby, or during removal of any weeds or debris from the intake grate.



- ⚠ Riding with a passenger(s) or pulling other boats, tubes, skier or wakeboarder makes the craft handle differently and requires greater skill. Do not overload the craft or take on more passengers than designated for the particular craft. Overloading can affect maneuverability, stability and performance. Avoid adding on accessories, or equipment which may alter your control of the craft. The craft may be fitted with tow eyelets which can be used to attach a ski rope. However, do not use these eyelets or the craft's cleats to tow a parasail. Severe craft damage may occur.
- ⚠ In shallow water, proceed with caution and at very low speeds. Grounding or abrupt stops may result in injury. Debris may also be picked up and be thrown rearward by the jet pump onto people or property.
- ⚠ Respect no wake zones, the rights of other water users and the environment. As the "skipper" and owner of a boat you are responsible for damage to other boats caused by the wake of your craft. Allow no one to throw refuse overboard.
- ⚠ This craft is equipped with navigation lights which should be used between sunset and sunrise. Reduce speed and do not operate the craft in reduced visibility.
- ⚠ Remember, gasoline fumes are flammable and explosive. Always adhere to the fueling procedure contained in this guide and those given to you by the marina. Always verify fuel level before use and during the ride. Apply the principle of 1/3 fuel to destination, 1/3 back and 1/3 reserve fuel supply. Do not carry spare fuel or inflammable liquids in any of the storage or engine compartments.
- ⚠ Combustion engine needs air to operate; consequently this craft can not be totally watertight. Any maneuvers such as figure eights etc., that cause the upper deck to be under water may cause severe engine problems due to water ingestion. Refer to SPECIAL PROCEDURES and LIMITED WARRANTY contained in this guide.
- ⚠ Operation of this craft by a minor or disabled person is NOT recommended.

Maintenance

- ⚠ Only perform servicing procedures which are detailed in this guide. Further assistance or information can be obtained from your authorized SEA-DOO sport boat dealer. In many instances proper tools and training is required for certain servicing or repair procedures.
- ⚠ Maintain the craft and equipment in top condition at all times. Adhere to the prescribed maintenance schedules. An annual inspection of the craft is always a good recommendation that should be followed.
- ⚠ The bilge must be kept clean of oil, water or other foreign materials.
- ⚠ Do not attempt to lift the craft without special equipment and training.
- ⚠ The engine and the corresponding components identified in this guide should not be utilized on product(s) other than for those they were designed. Maintenance procedures and specified tightening torque must be strictly adhered to. Never attempt repairs unless the appropriate tools are available. These craft are designed with parts dimensioned in both the metric and the imperial systems. When replacing fasteners, make sure to use only those recommended by Bombardier. If required, contact your authorized SEA-DOO sport boat dealer for further servicing information.
- ⚠ Operate your craft prudently and have fun. Don't forget that all persons must assist other boaters in an emergency.

LIST OF DISTRIBUTORS

NORTH AMERICA

<p>USA</p>  <p>(Except Puerto Rico)</p>	<p>BOMBARDIER MOTOR CORPORATION OF AMERICA</p> <p>7575, Bombardier Court WAUSAU, WI. 54401 Phone: (715) 848-4957 Fax: (715) 847-6879 http://www.bombardier.com</p>
<p>CANADA</p> 	<p>BOMBARDIER INC.</p> <p>RECREATIONAL PRODUCTS 75, J.A. BOMBARDIER ST. SHERBROOKE, QC J1L 1W3 Phone: (819) 566-3366 Fax: (819) 566-3062 http://www.bombardier.com</p>

If your SEA-DOO sport boat requires warranty service, you should take it to any authorized SEA-DOO sport boat dealer. Be sure to bring your warranty registration card or other valid proof of the original date of purchase. If a question or problem arises regarding warranty, first contact the service manager or owner of the SEA-DOO sport boat dealership.

To find the nearest authorized SEA-DOO sport boat dealer, dial: 1-800-882-2900.

NOTE: If outside Canada and USA, consult the local distributor.

BOMBARDIER LIMITED WARRANTY NORTH AMERICA: SEA-DOO® SPORT BOAT

1. WARRANTY COVERAGE PERIOD

In Canada, BOMBARDIER INC. ("Bombardier"), and in the U.S.A., Bombardier on behalf of BOMBARDIER MOTOR CORPORATION OF AMERICA (BMCA), warrants FROM THE DATE OF DELIVERY TO THE FIRST CONSUMER that each SEA-DOO SPORT BOAT sold, as NEW and UNUSED and PREDELIVERED by an authorized North American SEA-DOO SPORT BOAT dealer, will be free from any defects in material and/or workmanship for a PERIOD of:

a) For private use:

TWELVE (12) CONSECUTIVE MONTHS, with the exception of the deck and hull fiberglass structure; and

SIXTY (60) CONSECUTIVE MONTHS for the deck and hull fiberglass structure.

b) For commercial use:

FOUR (4) CONSECUTIVE MONTHS, with the exception of the deck and hull fiberglass structure; and

TWELVE (12) CONSECUTIVE MONTHS for the deck and hull fiberglass structure.

All genuine Bombardier accessories, installed by an authorized SEA-DOO SPORT BOAT dealer at the time of delivery of the new and non-current new SEA-DOO SPORT BOAT, carry the same Warranty Coverage Period as for the SEA-DOO SPORT BOAT.

2. WHAT BOMBARDIER WILL DO

BOMBARDIER will repair or replace, at its option, all genuine BOMBARDIER part found defective in material and/or workmanship, under normal use, maintenance and service, with a genuine BOMBARDIER part without charge for parts and labor, at any authorized SEA-DOO SPORT BOAT dealer during the Warranty Coverage Period.

3. CONDITION TO HAVE WARRANTY WORK VALIDATED

The customer must notify an authorized SEA-DOO SPORT BOAT dealer within two (2) days of the appearance of the defect in material and/or workmanship a proof of purchase of the NEW and UNUSED SEA-DOO SPORT BOAT and must sign the repair/work order prior to the start of the repair in order to validate a warranty repair. All parts replaced under this limited warranty become the property of BOMBARDIER.

4. EXCLUSIONS — ARE NOT WARRANTED

- The engine and corresponding components which are warranted by Mercury Marine. Refer to *M² Jet Drive Operator's Guide*.
- Normal wear and tear items;
- Labor, parts and lubricant costs of all maintenance services;
- Damages caused by failure to provide proper maintenance and/or storage, as described in the "*SEA-DOO SPORT BOAT Operator's Guide*";
- Damages resulting from improper repairs, modifications or use of non-approved parts or, repairs not performed by an authorized SEA-DOO SPORT BOAT dealer;
- Damages resulting from abuse, misuse, neglect, racing;
- Damages resulting from accident, fire, theft, vandalism or any act of God;
- Incidental or consequential damages, or damages of any kind such as but not limited to towing charges, telephone calls or taxi;
- Water damages caused by water ingestion;

- Damages related to gel coat finish including but not limited to cosmetic gel coat finish, blisters or fiberglass delamination caused by blisters, crazing, spider or hair-line cracks; and
- Damages resulting from improper service or maintenance.

5. LIMITATIONS OF LIABILITY

This warranty gives you specific rights, and you may also have other legal rights which may vary from state to state, or province to province. **WHERE APPLICABLE, THIS WARRANTY IS EXPRESSLY GIVEN AND ACCEPTED IN LIEU OF ANY AND ALL OTHER WARRANTIES, EXPRESSED OR IMPLIED, INCLUDING WITHOUT LIMITATION ANY WARRANTY OF MERCHANTABILITY OR FITNESS FOR ANY PARTICULAR PURPOSE.**

Neither the distributor, any authorized SEA-DOO SPORT BOAT dealer nor any other person has been authorized to make any affirmation, representation or warranty other than those contained in this warranty, and if made, such affirmation, representation or warranty shall not be enforceable against BOMBARDIER or any other person.

In no event shall BOMBARDIER be liable for special, consequential or incidental damages, including but not limited to loss of use and transportation costs. Some states or provinces do not allow the exclusion or limitation of incidental or consequential damages, or limitations on how long an implied warranty lasts, so the above limitation or exclusion may not apply.

BOMBARDIER reserves the right to modify this warranty at any time, being understood that such modification will not alter the warranty conditions applicable to the SEA-DOO SPORT BOAT sold while this warranty is in effect.

6. TRANSFER

If the customer sells the SEA-DOO SPORT BOAT guaranteed under the present, he shall assign and transfer this warranty, which shall be valid for the rest of the relevant PERIOD as defined in section 1 hereinabove, to the new customer.

7. CONSUMER ASSISTANCE

- In the event of a controversy or a dispute arising in connection with this BOMBARDIER LIMITED WARRANTY, BOMBARDIER suggests that you try to resolve the issue at the dealership level. We recommend discussing the issue with the authorized dealer's service manager or owner.
- If further assistance is required, Bombardier's Customer Assistance Department should be contacted in order to resolve the matter:

In Canada: (819) 566-3366

In the U.S.A.: (715) 848-4957

Or in writing at

IN CANADA AND U.S.A.:

BOMBARDIER INC.

RECREATIONAL PRODUCTS

CUSTOMER ASSISTANCE CENTER

75, J.-A. BOMBARDIER STREET

SHERBROOKE, QC

J1L 1W3

JULY 2002

® Registered trademark of Bombardier Inc. and/or subsidiaries.

BOMBARDIER INTERNATIONAL LIMITED WARRANTY: SEA-DOO® SPORT BOAT

1. WARRANTY COVERAGE PERIOD

BOMBARDIER INC. ("Bombardier"), as manufacturer, warrants FROM THE DATE OF DELIVERY TO THE FIRST CONSUMER that each SEA-DOO SPORT BOAT sold anywhere in the world except the United States and Canada, as NEW and UNUSED and PREDELIVERED by an authorized SEA-DOO SPORT BOAT dealer, duly appointed by an authorized SEA-DOO International Distributor, will be free from any defects in material and/or workmanship for a PERIOD of:

a) For private use:

TWELVE (12) CONSECUTIVE MONTHS, with the exception of the deck and hull fiberglass structure; and

SIXTY (60) CONSECUTIVE MONTHS for the deck and hull fiberglass structure.

b) For commercial use:

FOUR (4) CONSECUTIVE MONTHS, with the exception of the deck and hull fiberglass structure; and

TWELVE (12) CONSECUTIVE MONTHS for the deck and hull fiberglass structure.

All genuine Bombardier accessories, installed by an authorized SEA-DOO SPORT BOAT dealer at the time of delivery of the new and non-current new SEA-DOO SPORT BOAT, carry the same Warranty Coverage Period as for the SEA-DOO SPORT BOAT.

2. WHAT BOMBARDIER WILL DO

BOMBARDIER through the local authorized SEA-DOO International Distributor will, during the Warranty Coverage Period, repair or replace, at its option, all genuine BOMBARDIER part found defective in material and/or workmanship, under normal use, maintenance and service, with a genuine BOMBARDIER part without charge for parts and labor, at any local authorized SEA-DOO SPORT BOAT dealer.

3. CONDITION TO HAVE WARRANTY WORK VALIDATED

The customer must notify a local authorized SEA-DOO SPORT BOAT dealer within two (2) days of the appearance of the defect in material and/or workmanship and present to the servicing authorized SEA-DOO SPORT BOAT dealer the SEA-DOO Warranty Registration Card or a proof of purchase of the NEW and UNUSED SEA-DOO SPORT BOAT and must sign the repair/work order prior to the start of the repair in order to validate a warranty repair. All parts replaced under this limited warranty become the property of the international SEA-DOO distributor of the specific territory and/or BOMBARDIER.

4. EXCLUSIONS — ARE NOT WARRANTED

- The engine and corresponding components which are warranted by Mercury Marine. Refer to *M² Jet Drive Operator's Guide*.
- Normal wear and tear items;
- Labor, parts and lubricant costs of all maintenance services;
- Damages caused by failure to provide proper maintenance and/or storage, as described in the "*SEA-DOO SPORT BOAT Operator's Guide*";
- Damages resulting from improper repairs, modifications or use of non-approved parts or, repairs non-performed by an authorized SEA-DOO SPORT BOAT dealer;
- Damages resulting from abuse, misuse, neglect, racing;

- Damages resulting from accident, fire, theft, vandalism or any act of God;
- Incidental or consequential damages, or damages of any kind such as but not limited to towing charges, telephone calls or taxi;
- Water damages caused by water ingestion;
- Damages related to gel coat finish including but not limited to cosmetic gel coat finish, blisters or fiberglass delamination caused by blisters, crazing, spider or hair-line cracks; and
- Damages resulting from improper service or maintenance.

5. LIMITATIONS OF LIABILITY

This warranty gives you specific rights, and you may also have other legal rights resulting from the application of mandatory national laws which may vary from country to country. **WHERE APPLICABLE, THIS WARRANTY IS EXPRESSLY GIVEN AND ACCEPTED IN LIEU OF ANY AND ALL OTHER WARRANTIES, EXPRESSED OR IMPLIED, INCLUDING WITHOUT LIMITATION ANY WARRANTY OF MERCHANTABILITY OR FITNESS FOR ANY PARTICULAR PURPOSE.**

In no event shall BOMBARDIER be liable for special, consequential or incidental damages, including but not limited to loss of use and transportation costs. Some countries do not allow the exclusion or limitation of incidental or consequential damages, or limitations on how long an implied warranty lasts, so the above limitation or exclusion may not apply.

Neither the distributor, any authorized SEA-DOO SPORT BOAT dealer nor any other person has been authorized to make any affirmation, representation or warranty other than those contained in this warranty, and if made, such affirmation, representation or warranty shall not be enforceable against BOMBARDIER or any other person.

Every SEA-DOO SPORT BOAT is sold with the English version of this warranty. Some authorized SEA-DOO International Distributor may elect to translate this warranty into local language, it is then understood and agreed that in the event of any discrepancies or inconsistencies between the two versions, the English version shall prevail.

It is the customer's responsibility to ensure that the SEA-DOO SPORT BOAT complies with all boating regulations and standards of any country, other than the original country of sale, where the SEA-DOO SPORT BOAT is intended to be used.

BOMBARDIER reserves the right to modify this warranty at any time, being understood that such modification will not alter the warranty conditions applicable to the SEA-DOO SPORT BOAT sold while this warranty is in effect.

6. TRANSFER

If the customer sells the SEA-DOO SPORT BOAT guaranteed under the present, he shall assign and transfer this warranty, which shall be valid for the rest of the relevant PERIOD as defined in section 1 hereinabove, to the new customer.

7. CONSUMER ASSISTANCE

- a) In the event of a controversy or a dispute arising in connection with this BOMBARDIER INTERNATIONAL LIMITED WARRANTY, BOMBARDIER suggests that you try to resolve the issue at the dealership level. We recommend discussing the issue with the authorized dealer's service manager or owner.
- b) If further assistance is required, the authorized local SEA-DOO INTERNATIONAL DISTRIBUTOR's Service Department should be contacted in order to resolve the matter.

JULY 2002

® Registered trademark of Bombardier Inc. and/or subsidiaries

REGISTRATION NUMBER LOCATION

All craft are required by federal law to be registered and legally numbered. Due to space availability for proper display of registration number, refer to the following illustration for location. The registration number should appear on each side of the craft.



TYPICAL

1. Registration number location

LOCATION OF THE IMPORTANT LABELS

The following labels are on your craft. If missing or damaged, they can be replaced free of charge. See an authorized SEA-DOO sport boat dealer.

Please read the following labels carefully before operating this craft.

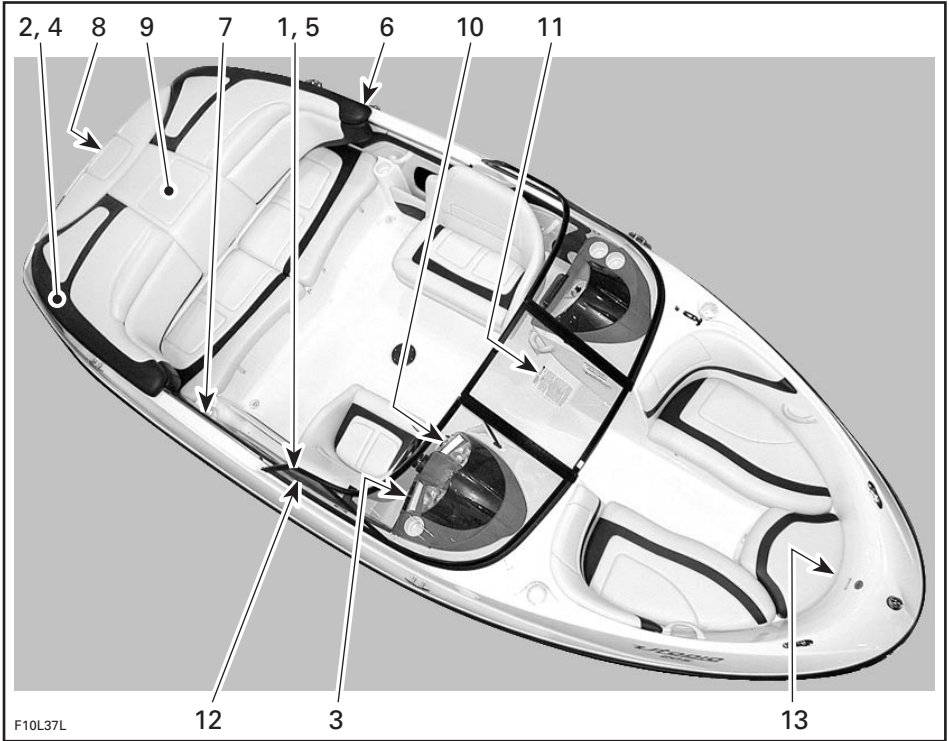

Utopia 205

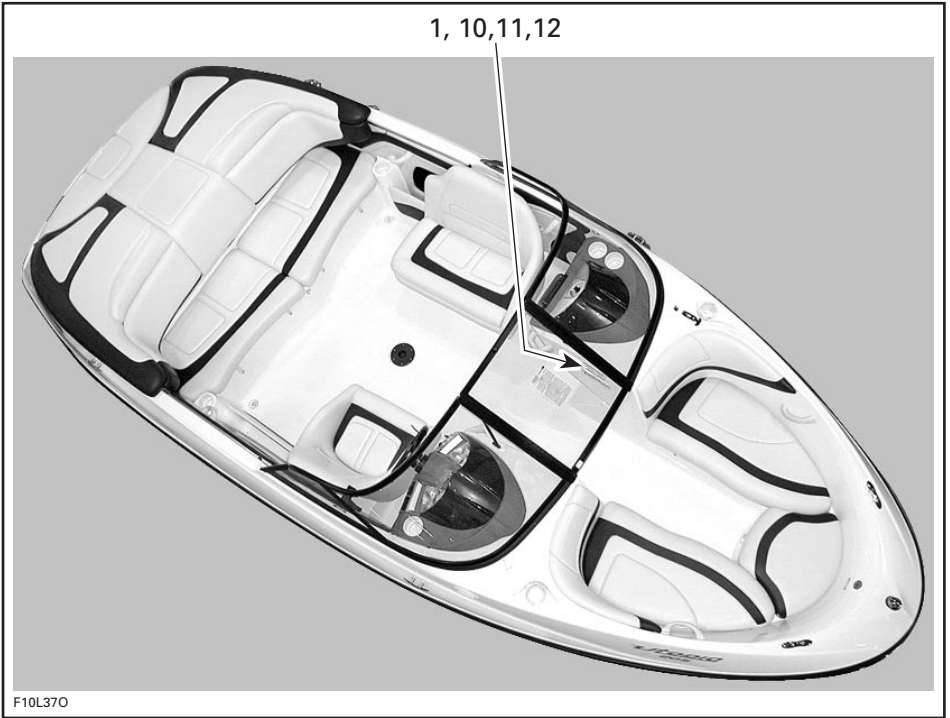

Label 1

MADE IN U.S.A., BOMBARDIER MOTOR CORPORATION OF AMERICA

MAXIMUM CAPACITIES

8 PERSONS OR 600 KG/1320 LBS.
600 KG/1320 LBS. PERSONS, GEAR

THIS BOAT COMPLIES WITH U.S. AND CANADIAN COAST GUARD SAFETY STANDARDS IN EFFECT ON THE DATE OF CERTIFICATION

CE

BOAT DESIGN CATEGORY: C

F10L30Y

TYPICAL — REFER TO ACTUAL LABEL ON CRAFT

Label 2

**MAXIMUM ENGINE POWER
CAPACITY RATING
OF THE CRAFT:**

185 KW

F04LAFY

TYPICAL — REFER TO ACTUAL LABEL ON CRAFT

Label 3

⚠ WARNING

Read and follow warning labels, operator guide and safety handbook before operation. Severe injury or death can result from ignoring warnings or through improper use of this sport boat. The performance of this sport boat may significantly exceed that of other boats you may have operated. Therefore, use of this sport boat by novice or inexperienced operators is not recommended.

- Check throttle/shifter and steering operation and position before starting engine(s).
- Directional control is reduced with decreasing speed and lost when engine is off.
- Do not splash others or jump waves or wakes with this sport boat.
- Operator and passengers should always wear approved PFD and recommended protective clothing.
- Do not operate if passengers are not properly seated and using handgrips, or if visibility is obstructed. Do not allow passenger(s) on most forward bow seat(s) above idle speed.
- Properly attach safety lanyard to your PFD.
- Keep a safe distance from all other water users. Be aware of and observe all applicable laws and regulations.

F04LABL

Label 4

⚠ WARNING

Do not boost battery. Servicing of electrical components should be done by authorized dealer only.

F04LALY

Label 6

⚠ WARNING

While fueling, stop engine(s). Fuel tank may be pressurized. Slowly turn cap when opening. Keep watercraft level. Do not overfill. Use regular unleaded gasoline. Check oil level. Periodically, inspect fuel system.

F04LATY

Label 5

⚠ WARNING

Gasoline vapors can explode. Before starting engine, operate blower for **5** minutes and check engine compartment bilge for gasoline vapors.

F04LASY

Label 7

⚠ WARNING

- Avoid body contact with bimini top.
- Operate this craft at a very low cruising speed with bimini top installed.
- Hold down straps are under tension.

F14L28Y

Label 8



Label 12



Label 9

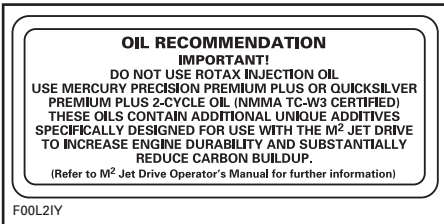

Label 13



Label 10



Label 14

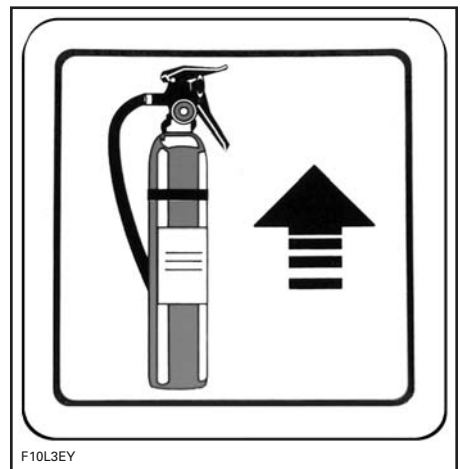

Label 11



IDENTIFICATION NUMBERS

The main components of the craft (engine and hull) are identified by different serial numbers. It may sometimes become necessary to locate these numbers for warranty purposes or to trace the craft in the event of theft.

Hull

The Hull Identification Number (H.I.N.) is located at right hand rear side of hull.

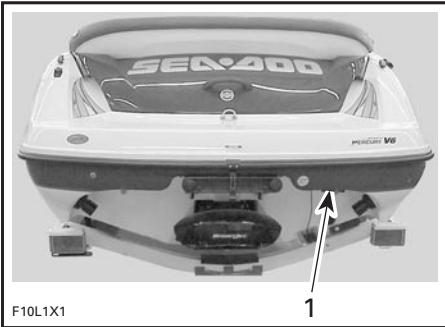

TYPICAL

1. Hull Identification Number (H.I.N.)

Engine

Refer to *M² Jet Drive Operator's Guide*.

CONTROLS, COMPONENTS AND INSTRUMENTS LOCATION

Cockpit

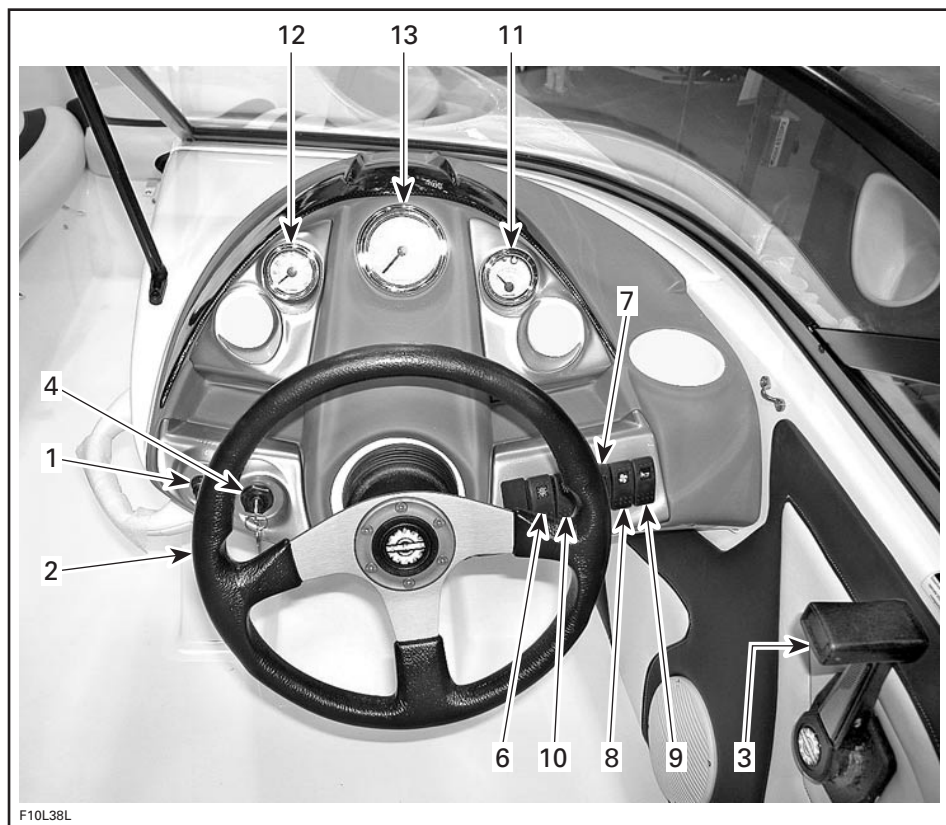

TYPICAL — COCKPIT VIEW

Overview

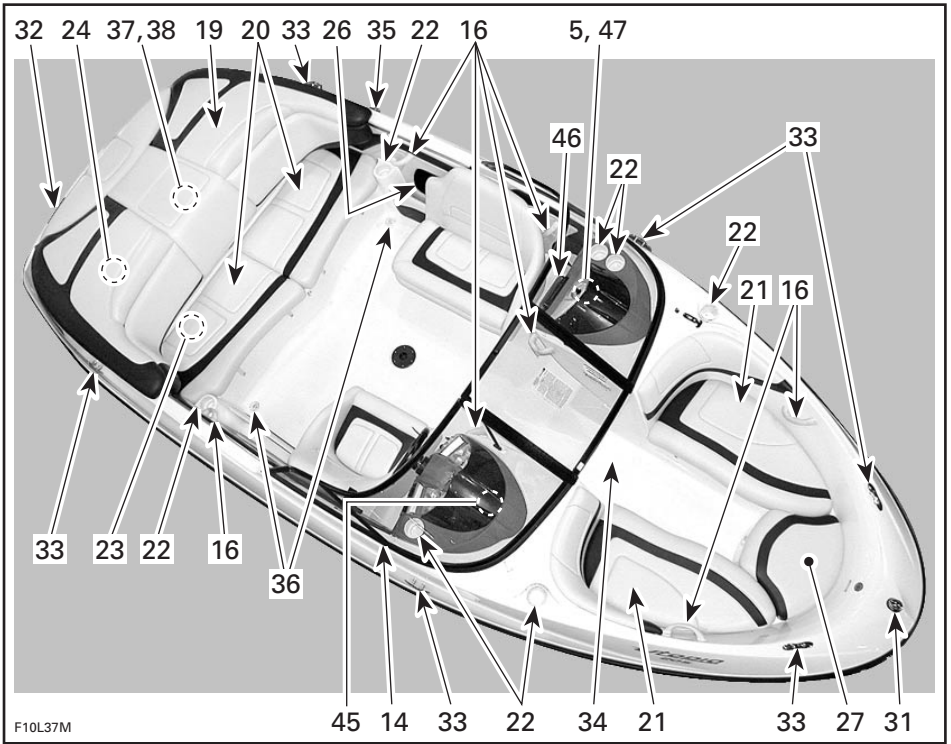

TYPICAL — TOP/SIDE VIEW

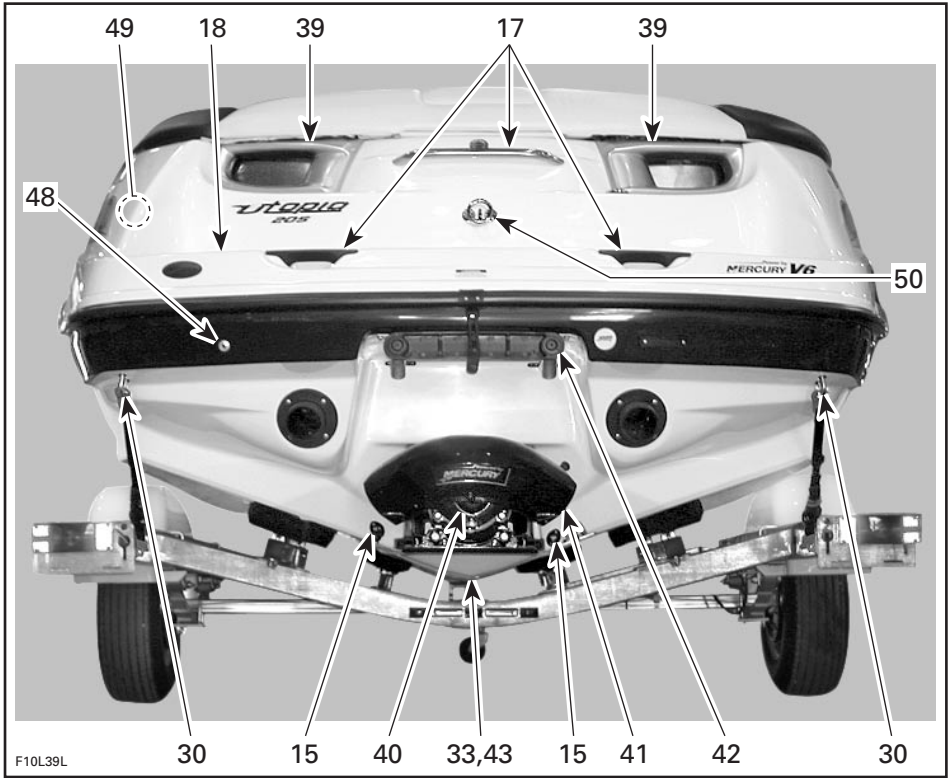

- | | |
|--|-----------------------------------|
| 1. Safety Lanyard (engine cut-out switch) | 21. Bow Seats (if so equipped) |
| 2. Steering Wheel | 22. Cup Holders |
| 3. Throttle/Shift Lever | 23. Rear Seat Storage Compartment |
| 4. Ignition Switch | 24. Rear Storage Compartment |
| 5. 12-Volt Accessory Jack | 25. Bimini Top (not shown) |
| 6. Navigation Light Switch | 26. Side Panel/Tray Storage |
| 7. Bilge Pump Switch | 27. Bow Anchor Locker |
| 8. Bilge Air Blower Switch | 28. Cockpit table (not shown) |
| 9. Horn Switch | 29. Jet Pump Water Intake |
| 10. Deck Light Switch | 30. Bow and Stern Eyelets |
| 11. Fuel Gauge/Low Oil Level Pilot Lamp and Beeper | 31. Bow Light |
| 12. Tachometer | 32. Removable Stern Light |
| 13. Speedometer | 33. Mooring Cleats |
| 14. Windshield | 34. Deck |
| 15. Bilge Drain Plugs | 35. Fuel Tank Cap |
| 16. Grab Handles | 36. Deck Drain(s) |
| 17. Rear Grab Handles | 37. Main Oil Reservoir Cap |
| 18. Swim Platform | 38. Flushing Connector |
| 19. Sun Deck | 39. Ventilation Ducts |
| 20. Seats | 40. Jet Pump Nozzle |
| | 41. Reverse Gate |

42. Retractable Ladder
43. Hydro-Surge Grate System
44. Fuel Tank Vent
45. Fuses
46. Radio/CD Player
47. Glove Box
48. Water Bypass System
49. Main Battery Cut-Off Switch
50. Ski Tow

CONTROLS, COMPONENTS AND INSTRUMENTS FUNCTIONS

1) Safety Lanyard (engine cut-out switch)

The safety lanyard cap should be securely snapped onto its switch to be fully operational.

Pulling the safety lanyard cap from the switch stops the engine operation. Attach the safety lanyard to the operator's Personal Flotation Device (PFD) and snap the cap to the switch to be able to start the engine.

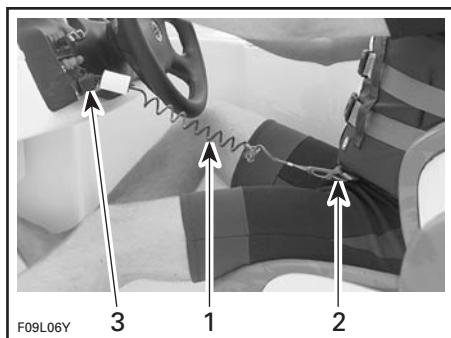

TYPICAL

1. Safety lanyard
2. Secure to PFD
3. Snap to safety lanyard switch

WARNING

Should the engine be stopped, craft directional control is lost. Always disconnect safety lanyard when craft is not in operation in order to prevent accidental engine starting or to avoid unauthorized use by children or others or theft.

2) Steering Wheel

The steering wheel controls the direction of the craft. Turning the steering wheel clockwise steers the craft to the right and inversely.

Low-Speed Steering Control System

Whenever the engine RPM is at idle and the steering wheel is approaching the end of its rotation, the engine speed will be slightly accelerated to increase the jet pump thrust and thus improving the steering control for low speed operation and when approaching/leaving a dock. Refer to OPERATING INSTRUCTIONS for more details.

3) Throttle/Shift Lever

A 3-position lever:

- forward
- neutral
- reverse.

When pushed forward craft accelerates. When fully pulled back, engine return to idle speed and the craft is gradually stopped by water drag.

Throttle/shift lever must be in neutral position to allow engine starting.

WARNING

Only use reverse at slow speed and for the shortest time possible. Always ensure the path behind is clear of objects and persons including children playing in shallow water.

CAUTION: Never rev the engine at high RPM in reverse.

4) Ignition Switch



TYPICAL

1. Ignition switch

Starting and Stopping

Refer to *M² Jet Drive Operator's Guide* for complete detailed procedure.

WARNING

Directional control is lost when engine is off.

5) 12-Volt Accessory Jack

Located in the glove box. A 12-volt jack to power temporary accessories such as a cooler, cellular phone or portable television.



1. 12-volt jack

CAUTION: Using the radio, cooler, cellular phone or portable television for a prolonged time without engine running may discharge the battery.

6) Navigation Light Switch

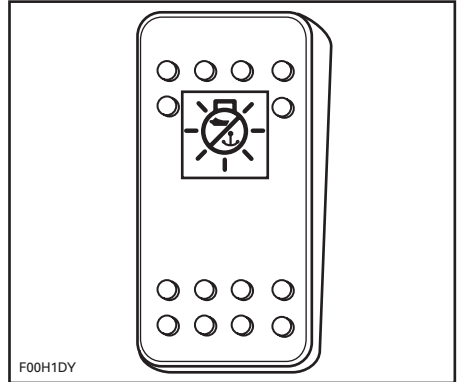

A 3-POSITION NAV/OFF/ANC PUSH TYPE SWITCH

Press switch to first position to turn on the stern light (anchorage position).

Press switch to second position to turn on the bow and stern lights.

Press to OFF position to turn off navigation lights.

NOTE: Switches and gauges are lit when navigation lights are turn on. Lights may be operated without the safety lanyard on its switch.

WARNING

Navigation lights should always be used between sunset and sunrise. Ensure the stern light is installed. See **REMOVABLE STERN LIGHT** in this section for location and installation.

7) Bilge Pump Switch

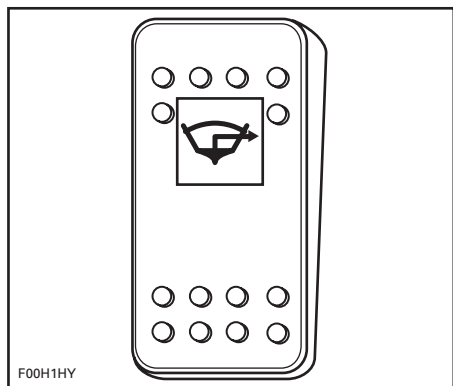

A 2-POSITION PUSH TYPE SWITCH

Press switch to ON position when a manual operation is required (after cleaning, storage, etc.).

Press to OFF position when bilge is dry.

CAUTION: Using the bilge pump for a prolonged time when the engine is not running will discharge the battery.

NOTE: The bilge pump may be operated without the safety lanyard on its switch.

CAUTION: Ensure to always turn pump OFF when bilge is dry or before operating the engine above idle. Bilge pump will then switch to automatic mode.

Automatic Bilge Pump

An automatic bilge pump will evacuate water from the bilge. A water sensor detects the water which activates the bilge pump. After the water is pumped out, the pump shuts-off automatically. This automatic mode is working at all times: with/without safety lanyard on its switch and with/without engine running.

8) Bilge Air Blower Switch

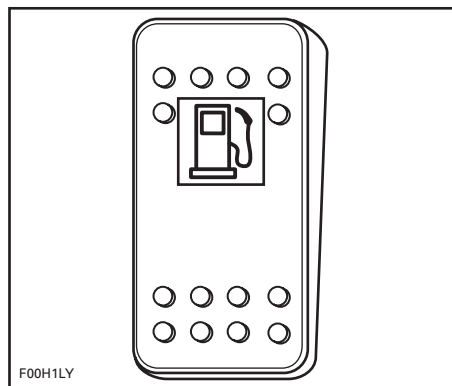

A 2-POSITION PUSH TYPE SWITCH

When ON, it ventilates the engine compartment.

WARNING

Always use blower for a minimum of 5 minutes prior to engine starting then, turn it OFF above idle speed. Use of the bilge blower should never replace "smelling" for gasoline vapors.

CAUTION: Using the bilge blower for a prolonged time when the engine is not running will discharge the battery.

Blower should be turned off during boat operation.

9) Horn Switch

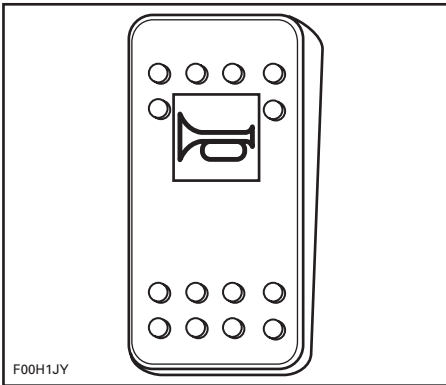

A 2-POSITION PUSH TYPE SWITCH

Press and hold the switch to activate horn.

Release the switch to stop horn.

10) Deck Light Switch

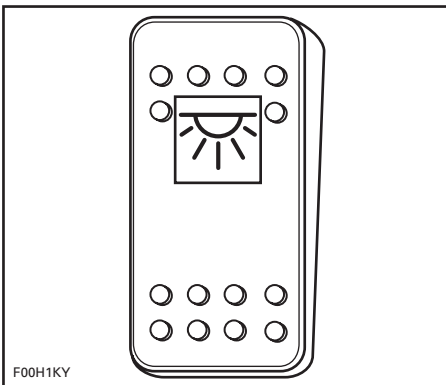

A 2-POSITION PUSH TYPE SWITCH

CAUTION: Using the deck lights for a prolonged time when the engine is not running will discharge the battery.

11) Fuel Gauge/Low Oil Level Pilot Lamp and Beeper

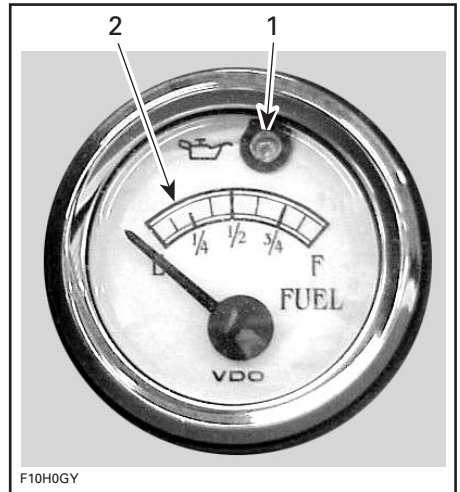

TYPICAL

1. Low injection oil level pilot lamp
2. Fuel level

Fuel Gauge

Located in dashboard, the analog gauge continuously indicates the amount of fuel in fuel tank when engine is running.

The gauge is illuminated whenever the navigation lights are used.

NOTE: The fuel level can also be verified without having engine running. With the safety lanyard removed from its switch, turn ignition switch to ON position; the gauge will be activated.

CAUTION: Always turn ignition switch to OFF position once fuel level has been checked.

Low Oil Level Pilot Lamp and Beeper

The pilot lamp and the beeper turn on when the oil level is low in engine mounted oil reservoir or if a wire/connector of this electrical circuit is not properly connected. Fill reservoirs as soon as possible or contact an authorized SEA-DOO sport boat dealer if light or beeper remain on.

CAUTION: Never run engine out of oil. Serious engine damage will occur.

12) Tachometer

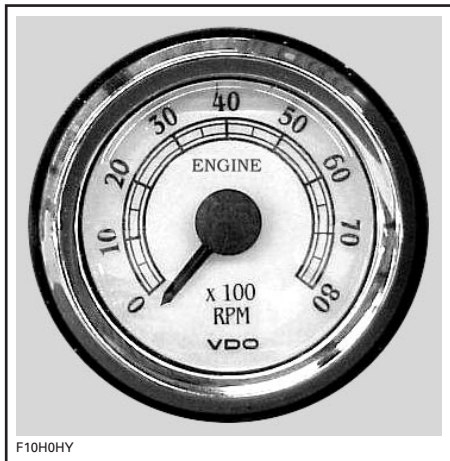

TYPICAL

Analog tachometer indicates the revolutions per minute (RPM) of the engine. Multiply reading by 100 to obtain actual RPM.

The gauge is illuminated whenever the navigation lights are used.

13) Speedometer

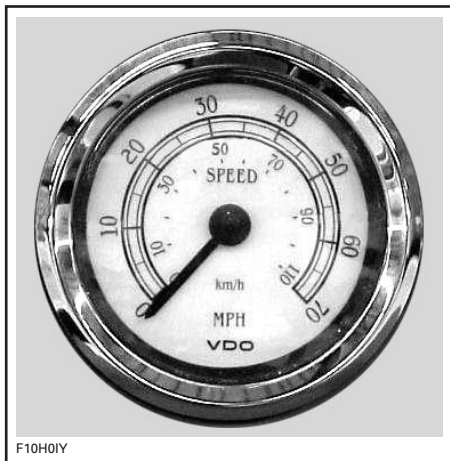

TYPICAL

Analog speedometer indicates the speed of the craft in miles per hour (MPH) and kilometers per hour (km/h).

The gauge is illuminated whenever the navigation lights are used.

A speed sensor mounted on the hull near *M² Jet Drive* sends the signal to the speedometer.

14) Windshield

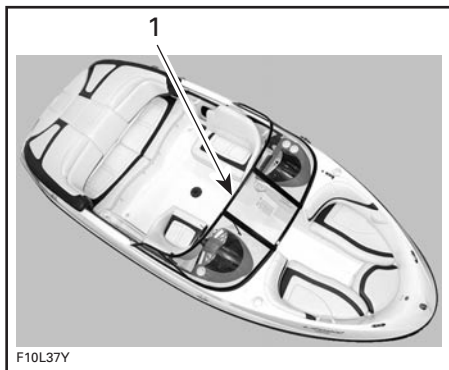

1. Windshield

To open windshield door, unlock both latches then open it, as shown in the following photo.

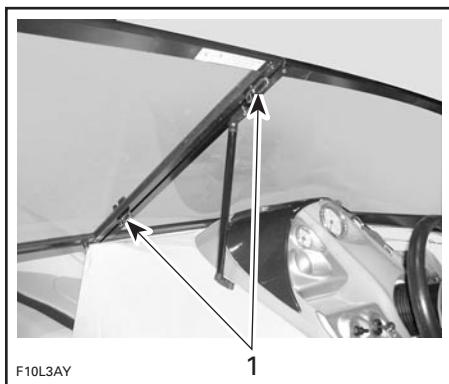

1. Unlock both latches

15) Bilge Drain Plugs

Should water be found in the bilge, it can be easily drained by unscrewing the drain plugs.

Tilt the craft slightly to the rear so that the water can completely flow out of the bilge.

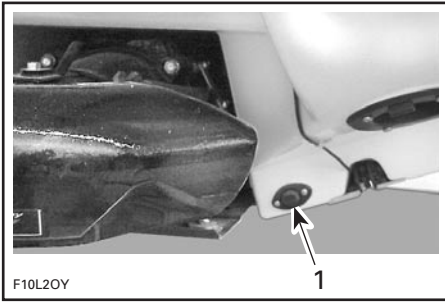

1. Bilge drain plug

16) Grab Handles

Provide a handhold for the passengers.

CAUTION: Never use the grab handles to pull anything or to lift the craft.

Refer to components location illustrations at the beginning of this section for grab handles location.

17) Rear Grab Handles

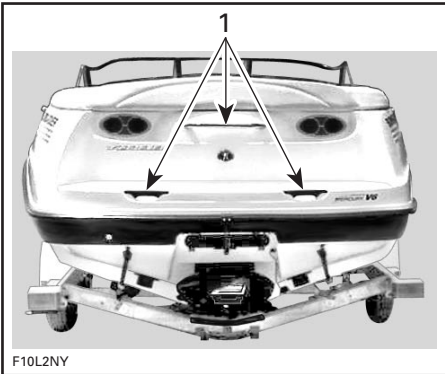

TYPICAL

1. Grab handles

Provides a handhold for boarding when needed.

CAUTION: Never use the grab handle to tow anything or to lift the craft.

18) Swim Platform

Provides an anti-skid surface for easy boarding from rear of craft.

WARNING

Do not start or operate the craft if a person is seated on the platform. Engine must be off when using swim platform. Keep away from jet or intake grate.

19) Sun Deck

A convenient space to rest or take some sun while anchored.

WARNING

Do not start or operate the craft if a person is seated on the sun deck.

20) Seats

Each passenger should be seated while underway.

WARNING

Allow no one to sit on edge of craft or to stand up while in operation. Seat/grab handles should be used in rough waters.

Front Seats

Swivel

Both front seats can swivel backward by pulling lever, as shown in the next photo.



PULL LEVER

⚠ WARNING

Always ensure front seat swivel is locked so that seat faces steering wheel before riding.

**21) Bow Seats
(if so equipped)**

Located at front of craft, they are provided as a sun seat.

Use grab handles as necessary.

**Bow Seat Storage
Compartments**



To reinstall seat, ensure to position L-bracket first, push seat down then snap it.



1. Position L-bracket first

22) Cup Holders

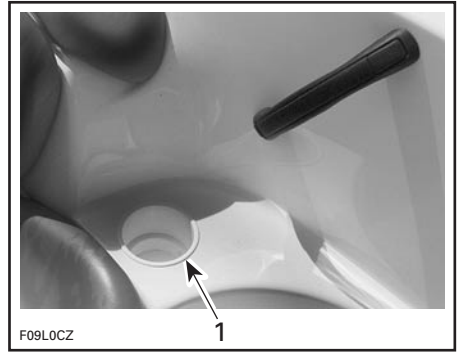

1. Cup holder

Convenient locations for non-alcoholic beverages.

⚠ WARNING

Do not drink alcoholic beverages while aboard. Do not keep bottles, cans etc. in cup holders while riding at speed and/or on rough waters.

**23) Rear Seat Storage
Compartment**

The rear seat storage compartment is a convenient location for water-skis, paddles, anchor and rope, etc.

⚠ WARNING

Never leave any heavy or breakable objects in the storage compartment. Never operate the craft with the storage compartment cover open.

24) Rear Storage Compartment



REAR STORAGE COMPARTMENT

1. Engine cover opened

Convenient rear storage location to be used to carry large personal articles. Ideal location for spare Personal Flotation Device (PFD), towels, lunch etc.

To open engine cover, unstrap the straps then lift it.

The gas assist cylinders will ease opening and hold engine cover open.

WARNING

Never leave any heavy or breakable objects in the storage compartment. Never operate the craft with the engine cover open.

25) Bimini Top

The Bimini top is convenient for protection against inclement weather or sunshine.

WARNING

- Avoid body contact with Bimini top.
- Operate this craft at a very low cruising speed with Bimini top installed.
- Hold down straps are under tension.
- For daytime use only to insure visibility of navigation lights.

Opening Bimini Top

Lift sun pad lid.

Slightly raise Bimini top above engine storage compartment and slide all the way to front of side rails.



1. Bimini pivot base pulled forward on rail

Unzip cover and remove. Store cover in a storage area.

Lift Bimini top to vertical position and connect front straps to eyelets on body of craft.



1. Hook strap to body eyelet

Pull canvas back and fasten rear straps to eyelets on body of craft.

Adjust strap tension as needed.

Close sun pad lid.

Closing/Storing Bimini Top

NOTE: If canvas of Bimini top has been splashed by salt water, rinse canvas with cold fresh water. At any time when canvas is wet, let dry prior to installing cover and storage.

Open sun pad lid.

Unhook rear straps.

Unhook front straps.

Before laying the Bimini top down, hold the top/front tube and pull the second and third tubes toward the top/front tube.

Tilt Bimini top back towards storage compartment.

Position the protective cover so that the zipper will be on the inner side of the Bimini top and the starting end of the zipper will be on starboard side of boat.

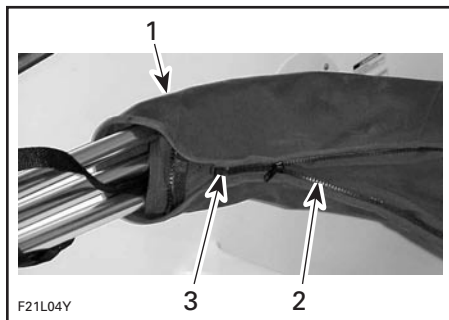

1. Bimini top at rear storage compartment area
2. Inner side of zipper
3. Start of zipper

Place Bimini top straps inside cover and slowly zip while packing canvas inside cover.

Slide Bimini top to the rear of side rail to store Bimini top underneath sun pad lid.

Close sun pad lid.

Removing Bimini Top from Boat

If it becomes necessary to remove Bimini top from boat, proceed as follows:

Open sun pad lid.

Remove fasteners at pivot point.

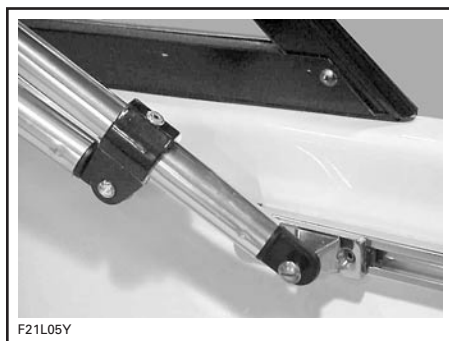

TYPICAL

With the assistance, carefully lift Bimini top and remove.

Reinstall pivot fasteners to prevent loss.

Installation is procedure in reverse, however, pay attention to Bimini top orientation for proper positioning.

Close sun pad lid.

Utopia 205 Only

26) Side Panel/Tray Storage

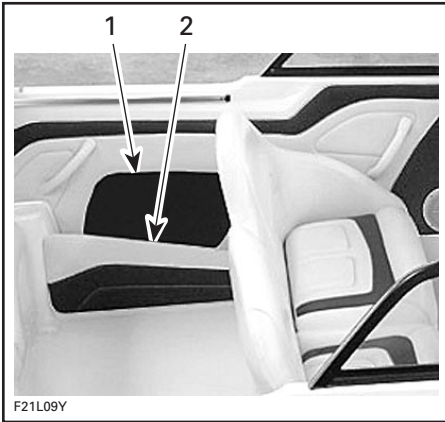

1. Side panel storage
2. Side tray storage

Located at the port and starboard sides of the craft, these storage areas provide quick, easy access for additional articles.

WARNING

Never leave any heavy or breakable objects in the storage compartment. Never operate the craft with the storage compartment cover open.

27) Bow Anchor Locker

Located under the forward bow cushion with storage for anchor and line.



TYPICAL

WARNING

Never leave breakable objects in the anchor storage compartment. Never operate the craft with the anchor storage compartment cover open.

28) Cockpit Table

Conveniently stored atop the engine cover.



COCKPIT TABLE IN STORAGE POSITION

Swivel front seats into side-facing position.

Open sun pad lid.

Unclip table post and place in floor receptacle. Twist gently to ensure proper fit.

WARNING

When front seats are in side facing position and table post not installed, floor receptacle poses potential hazard. Use proper judgement.



COCKPIT TABLE INSTALLED

Close sun pad lid.

Cockpit Table Storage

Storage of cockpit table is the reverse of installation.

WARNING

Cockpit table must be properly stored before operating craft.



1. Floor receptacle
2. Table post

Loosen bungie straps to remove table top, and connect with table post.

29) Jet Pump Water Intake

The water is drawn up by the impeller through this opening. It minimizes entry of foreign objects into the propulsion system.

WARNING

Keep away from intake grate while engine is on. Items such as long hair, loose clothing or personal flotation device straps can become entangled in moving parts resulting in severe injury or drowning.

Refer to *M² Jet Drive Operator's Guide* for more detailed information.

30) Bow and Stern Eyelets

Bow Eyelet

Eyelets can be used for mooring, towing and as a tie-down point during transportation.

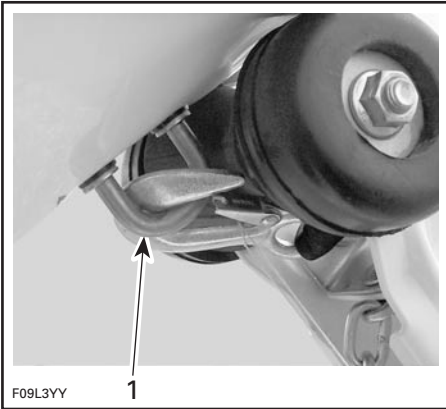

TYPICAL

1. Bow eyelet

Stern Eyelets

This eyelet allows a rope with a hook, a closes end or an open end to be attached.

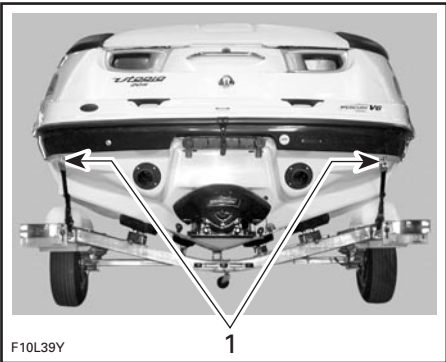

TYPICAL

1. Stern eyelets

31) Bow Light

Mandatory red/green light. See LIGHT SWITCH as mentioned earlier in this section.

32) Removable Stern Light

Mandatory white stern light.

It is recommended to keep it in rear seat storage compartment at all times except when needed.

To remove from storage compartment, pull it out. Snap in place to store again.

Installation

- Lift connector cap.
- Insert post in connector hole. Ensure to align hole keyway with post screw head.
- Firmly push downward to engage terminals.
- Push lock ring downward. Turn until locked. It may be necessary to slightly turn it to allow its insertion in the hole.
- Check light operation. See NAVIGATION LIGHT SWITCH as mentioned earlier in this section.

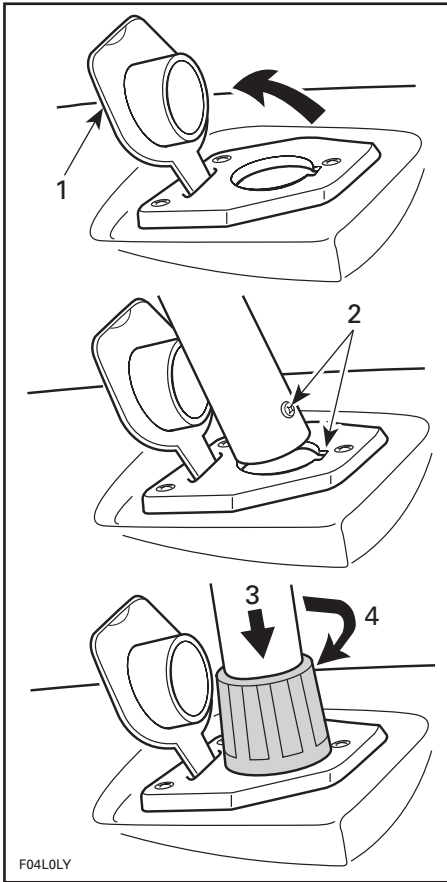

TYPICAL

1. Lift
2. Align screw in groove
3. Push downward
4. Turn to lock

CAUTION: Ensure dielectric grease is present in connector area of light to prevent corrosion.

33) Mooring Cleats

When mooring to a dock, it is recommended to secure with both front and rear cleats. The use of dock lines with sealed air fenders is recommended to protect your craft.

CAUTION: Never use mooring cleats to pull or lift the craft.

34) Deck

Flat surface of craft, should be kept clean and clear.

35) Fuel Tank Cap

Unscrew the cap counterclockwise. Reinstall cap and fully tighten after fueling.

⚠ WARNING

Always stop the engine before refueling. Fuel is inflammable and explosive under certain conditions. Always work in a well ventilated area. Do not smoke or allow open flames or sparks in the vicinity. Fuel tank may be pressurized, slowly turn cap when opening. Keep craft level. Do not overfill or top off the fuel tank and leave craft in the sun. As temperature increases, fuel expands and might overflow. Always wipe off any fuel spillage from the craft. Never use an open flame to check fuel level.

36) Deck Drain(s)

It provides drainage of water from rain, deck washing, water splashing, etc.

Keep clean to avoid clogging.

37) Main Oil Reservoir Cap

Open the engine cover to expose the oil cap.



To add injection oil in the reservoir, unscrew the cap counterclockwise.

WARNING

Add oil to level mark. Do not overfill. Reinstall cap and fully tighten.

CAUTION: Oil system must be pressurized. Always ensure that reservoir caps are firmly tightened. Refer to *M² Jet Drive Operator's Guide* for recommended oil and complete reservoirs filling procedure.

38) Flushing Connector

Refer to *M² Jet Drive Operator's Guide* for proper use.

For your convenience, flushing connector is located under engine cover. Lift cover, the flushing connector is on port side of the storage compartment, as shown in the next photo.

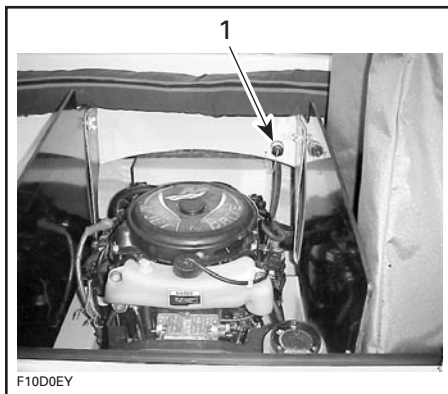

1. Flushing connector

39) Ventilation Ducts

This is where air flows to supply engine and ventilate engine compartment. They should never be obstructed.

40) Jet Pump Nozzle

Turns side to side via input from the steering wheel. This provides directional control when engine is running.

WARNING

Never use nozzle as a supporting point to board the craft or to lift it.

41) Reverse Gate

When selecting the neutral or reverse position with the throttle/shift lever, the reverse gate moves up or down to obtain the desired position.

WARNING

Never use gate as a supporting point to board the craft. Throttle/shift lever should only be used when the engine is idling and craft is completely stopped.

42) Retractable Ladder

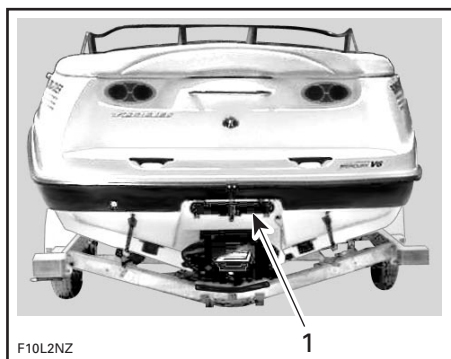

1. Retractable ladder

Located under swim platform. A convenient ladder to help reboarding the craft.

WARNING

Engine should be OFF when using ladder. Keep limbs away from jet or intake grate. Stay on center of the ladder. Only one person at the time on the ladder. Never use the ladder for pulling, towing, diving or jumping, boarding a craft that is out of water or any other purpose other than a ladder.

Pull latch to unlock the ladder.

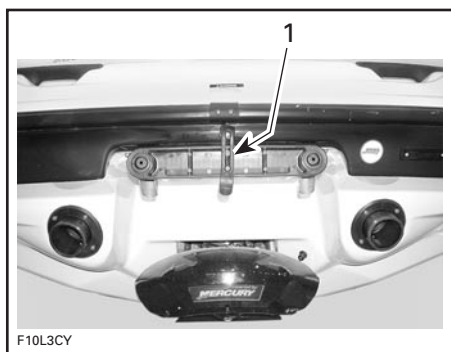

TYPICAL

1. Latch

Slide ladder toward rear, then push down.

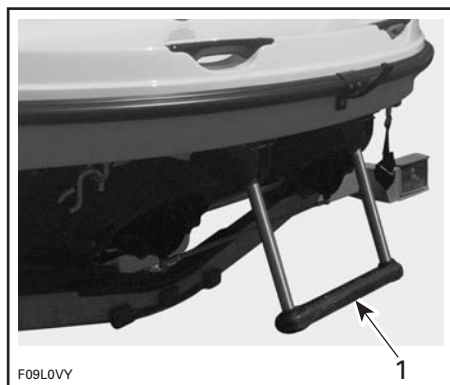

TYPICAL

1. Ladder lowered

To store ladder, lift horizontally completely then slide toward front.

43) Hydro-Surge Grate System

Refer to *M² Jet Drive Operator's Guide*.

44) Fuel Tank Vent

It allows fuel vapors and pressure to escape from fuel tank.

WARNING

Never use a lit match or open flame close to vent. Follow the FUELING PROCEDURE instructions in the FUEL AND LUBRICATION section.

45) Fuses

Craft electrical system fuses are located inside starboard console.

Refer to *M² Jet Drive Operator's Guide* for ENGINE ELECTRICAL SYSTEM.

46) Radio/CD Player

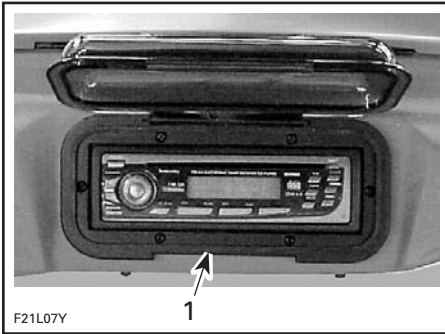

1. Radio/CD player

Refer to manufacturer's guide for complete explanation of features and controls.

CAUTION: Using the radio/CD player for a prolonged time without engine running may discharge the battery.

47) Glove Box

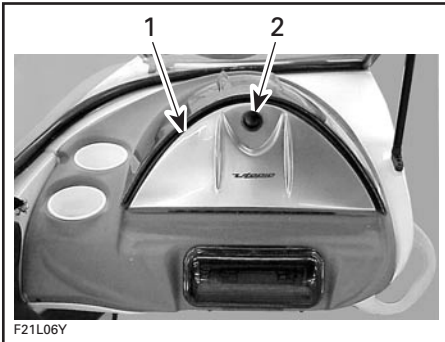

1. Glove box
2. Push button

Located on port console.

A small, convenient storage compartment for keys, wallet, etc.

To access the glove box, push button in and release. Turn knob either direction to open. To close, lift door and push forward until latched. Push button in to secure.

NOTE: Always relatch glove box.

WARNING

Never operate the craft with the glove box cover open.

48) Water Bypass System

At idle speed, there will not be a water flow through this outlet.

When engine is running above idle speed, water must flow through this hole. This allows air in engine water jacket to escape.



TYPICAL

1. Water bypass outlet

CAUTION: Should water not flow from the outlet a few seconds after engine starts and runs above idle, immediately stop engine and refer to POST-OPERATION CARE and look for COOLING SYSTEM FLUSHING or refer to an authorized SEA-DOO sport boat dealer for servicing.

49) Main Battery Cut-Off Switch

The switch is located in the engine compartment, close to battery. It is provided to allow a complete cut-out of the electrical system.

When in OFF position, ALL electrical equipments and electronics will not be powered and not working.

It must be in the ON position to allow the use of electrical components and to start the engine.

CAUTION: Stop engine before switching OFF.

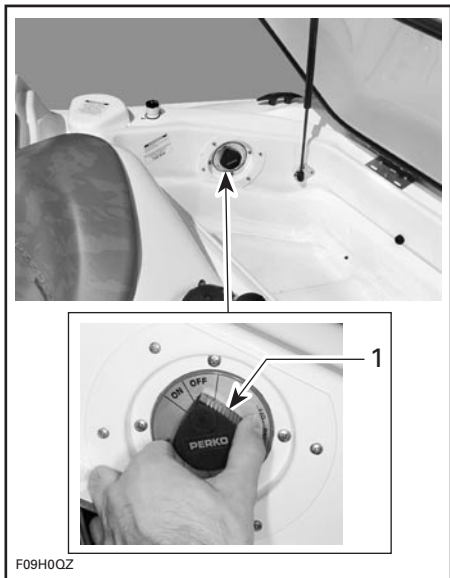

TYPICAL

1. Main battery cut-off switch

It is recommended to set in the OFF position whenever performing maintenance in the engine compartment, on the electrical system, for transportation and for short term storage on the trailer.

50) Ski Tow

Always have one person other than the operator as an observer.

CAUTION: Never use the ski tow to pull other boats.

WARNING

Riding when pulling a tube, skier or wake boarder makes the craft handle differently and requires greater skill. Unless absolutely necessary, do not make tight, sharp turns. Keep a safe distance from the docks, swimmers, other craft or objects. Be advised that serious injury can result if the tow rope becomes slack during a tight turn or when circling. The rope could become wrapped around the neck or limbs of a person.

FUEL AND LUBRICATION

CAUTION: Scrupulously follow the instructions of this section. Failure to do so may reduce the engine's life and/or performance.

Fueling Procedure

WARNING

Follow these safe boating fueling instructions explicitly.

Do not allow anyone to remain on the craft.

Tie craft securely to the fueling pier.

Use bilge blower for a minimum of 5 minutes.

Turn off bilge air blower, bilge pump and any other devices that could produce a spark.

Ensure engine cover is closed to prevent fumes from entering the engine compartment.

Have a fire extinguisher close at hand.

Do not insert the spout too far in filler neck.

Pour fuel slowly so that air can escape from the tank and prevent fuel flow-back.

Fill fuel tank to bottom of filler neck. **Do not overfill.** Fully tighten fuel tank cap.

WARNING

Always stop the engine before refueling. Fuel is flammable and explosive under certain conditions. Always work in a well ventilated area. Do not smoke or allow open flames or sparks in the vicinity. Fuel tank may be pressurized. Slowly turn cap when opening. Keep craft level. Do not overfill or top off the fuel tank and leave craft in the sun. As temperature increases, fuel expands and might overflow. Always remove any fuel spillage from the craft.

Recommended Fuel

Use regular unleaded gasoline with 87 octane (Ron + Mon/2) specification.

NOTE: This craft features an oil injection system which does not require manual fuel/oil mixing. Do not mix oil with fuel except at engine break-in. Refer to *M² Jet Drive Operator's Guide* BREAK-IN PERIOD. Always check oil reservoir level when refueling.

Refer to *M² Jet Drive Operator's Guide* for more detailed information.

CAUTION: The use of a fuel other than regular unleaded fuel can result in craft performance deterioration and damage to fuel system and engine components. Never experiment with other fuels or fuel ratios. Never use fuel containing alcohol, methanol or similar products including naphtha.

Recommended Oil

WARNING

Add oil to level mark. Do not overfill. Reinstall cap and fully tighten.

Use Quicksilver or Mercury Precision Premium-Plus lubricants NMMA/BIA certified TC-W3 2-cycle outboard oil or equivalent.

Refer to *M² Jet Drive Operator's Guide* specifications for more detailed information.

Main Oil Reservoir Level

A sufficient amount of oil should be maintained in the reservoir.

NOTE: Always carry a spare 1 liter of oil.

The use of a funnel is recommended to pour the oil into the reservoir. Stop filling as soon as oil appears at approximately 13 mm (1/2 in) from top of reservoir. Do not overfill. Wipe off any oil spillage.

CAUTION: Always maintain a sufficient amount of oil in the oil reservoir. Check and refill every time you refuel. Do not overfill. If the engine runs out of oil, severe engine damage will occur. If the oil reservoir is found almost empty, refer to an authorized SEA-DOO sport boat dealer to have the oil injection system inspected.

CAUTION: Oil system must be pressurized. Always ensure that reservoir caps are firmly tighten. Refer to *M² Jet Drive Operator's Guide* for complete reservoirs filling procedure.

Engine Mounted Oil Reservoir Level

Refer to *M² Jet Drive Operator's Guide*.

BREAK-IN PERIOD

CAUTION: Scrupulously follow the instructions of this section. Failure to do so may reduce the engine's life and/or performance.

Engine

Refer to *M² Jet Drive Operator's Guide*.

10-Hour Inspection

It is highly recommended that after the first 10 hours of operation, the craft be checked by an authorized SEA-DOO sport boat dealer. This inspection will also provide the opportunity to discuss any unanswered questions you may have encountered during the first hours of operation.

The following chart should be used in conjunction with Mercury chart. Refer to *M² Jet Drive Operator's Guide*.

The 10-hour inspection is at the expense of the craft owner.

10-HOUR INSPECTION CHECK LIST	✓
Fuel system lines and fasteners	
Throttle cable adjustment if required	
Oil lines	
Muffler, battery and reservoir fastening devices	
Exhaust system hose clamps torque	
Steering system and low-speed steering control system	
Steering cable adjustment if required	
Throttle/shift cable adjustment if required	
Ensure that throttle/shift lever keep the selected position. Adjust lever friction as necessary	
Hose condition and fasteners	
Bilge pump and bilge blower	
Safety lanyard switch	
Monitoring beeper	
Electrical connections (starter, battery, etc.)	
Lighting system inspection	
Hull condition	
Inspection of fasteners for tightness	

We recommend that this inspection chart be signed by an authorized SEA-DOO sport boat dealer.

Date of 10-hour inspection

Authorized dealer signature

Dealer code

PRE-OPERATION CHECKS

WARNING

The pre-operation check is very important prior to operating the vehicle. Always check the proper operation of critical controls, safety features and mechanical components before starting. If not done as specified here, severe injury or death might occur. Bring all safety equipment required by local laws.

Some of the following items may not have been previously covered in this guide, however they will be described in the MAINTENANCE or SPECIAL PROCEDURES section. Please refer to these portions to have more detailed information.

Prior to operating the craft, verify the following:

WARNING

Engine should be off and the safety lanyard must always be removed from its switch prior to verifying any of the following. Only start craft once all items have been checked and operate properly.

SUMMARY

ITEM	OPERATION	✓
Safety lanyard ignition switch	Check operation.	
Hull	Inspect.	
Jet pump water intake	Inspect/clean.	
Bilge	Drain. Ensure plug is secured.	
Battery	Inspect tightness of cables and retaining straps.	
Main battery cut-off switch	Ensure it is in the ON position.	
Navigation lights	Check operation.	
Fuel tank and oil reservoirs	Refill.	
Engine compartment	Verify fuel/oil system components.	
Steering	Check operation.	
Throttle/shift lever system	Check operation.	
Bilge blower and bilge pump	Check operation.	
Mandatory safety boating equipment	Check operation.	
Storage compartment covers and engine cover	Ensure they are closed and latched.	

Hull

Inspect hull for cracks or damage.

Jet Pump Water Intake

Remove weeds, shells, debris or anything else that could restrict the flow of water and damage the cooling system or propulsion units. Clean as necessary. If any obstruction can not be removed, refer to an authorized SEA-DOO sport boat dealer for servicing.

Inspect leading edges of the impellers, if they have nicks or bends, performance will be greatly reduced.

Bilge

Should water be present in the bilge, use bilge pump or tilt the craft to the rear and unscrew drain plugs if craft is out of the water, as the case may be, to completely empty the bilge.

Secure bilge drain plugs.

WARNING

Make sure drain plugs are properly secured prior launching the craft in water.

Battery

WARNING

Verify tightness of battery cables to their posts and condition of retaining straps/fasteners. Do not boost battery while installed.

Fuel Tank/Oil Reservoirs

With the craft horizontal, fill the fuel tank to specified level.

Check the oil level and refill reservoir as necessary.

CAUTION: Oil system must be pressurized. Always ensure that reservoir caps are firmly tighten. Refer to *M² Jet Drive Operator's Guide* for complete reservoirs filling procedure.

Check fuel tank/oil reservoirs retaining straps/fasteners.

Engine Compartment

WARNING

Should any leak or gasoline odor be present, do not start the engine. Consult an authorized SEA-DOO sport boat dealer before use.

Fire Extinguisher

Make sure it is full, in good condition and well secured.

Steering System

Assisted by another person, check steering operation for free movement. When the steering is centered, the jet pump nozzle should be in the straight ahead position. Ensure the jet pump nozzle pivots easily when steering is turned.

WARNING

Check steering and corresponding steering nozzle operation before starting.

Throttle/Shifter System

Check reverse gate operation for free movement. With throttle/shift lever in forward position, the gate should be in upward position. With the throttle/shift lever in neutral position, gate should be in middle position. With throttle/shift lever in reverse position, gate should be in downward position.

WARNING

Verify the throttle/shift lever lock at neutral position.

Inlet Grate

Ensure inlet grate is not blocked or obstructed by any weeds or debris. Refer to *M² Jet Drive Operator's Guide*.

Safety Lanyard and Ignition Switch

Ensure that ignition switch operates properly.

Start engine and stop it using switch.
See STARTING PROCEDURE.



WARNING

Only start craft once all items have been checked and operate properly.

Storage Compartment Covers

Ensure they are closed and latched.

OPERATING INSTRUCTIONS

WARNING

Always perform PRE-OPERATION CHECKS before operating the craft. Become thoroughly familiar with all controls and the function of each. Should any control or instruction be not fully understood, refer to an authorized SEA-DOO sport boat dealer.

Launching/Loading

CAUTION: Before launching the craft, ensure the main battery cut-off switch is turned ON and the bilge plugs are fully screwed.

After loading the craft, ensure the main battery cut-off switch is turned OFF and the bilge plugs are removed to drain bilge.

Trailing

Refer to the trailer or implement manufacturer instructions for proper capacity, operation, maintenance, accessories and warranty.

Check the regulations in your area concerning towing a trailer, especially the following rules:

- brake system
- tow vehicle weight
- mirrors.

NOTE: An optional brake system is available for your trailer, see an authorized SEA-DOO sport boat dealer.

Take the following precautions when trailering the craft:

Tie the craft to both bow and stern (front/rear) eyelets so that it is firmly retained on the trailer. Use additional tie-downs if necessary.

- Remove stern light (if installed).
- Ensure all storage compartment covers are properly latched.
- Ensure windshield door is securely locked in the closed position.
- A SEA-DOO cover can protect the craft, particularly before driving on dirt roads, to prevent dirt entry through the air intake opening(s).

Observe trailering safety precautions.

Principle of Operation

Propulsion

Engine is directly coupled to a drive shaft which, in turn, rotates an impeller. This impeller is accurately adjusted in a housing where the water is drawn up from underneath the craft. Then, the water flows through the impeller to a venturi. The venturi accelerates the water and produces thrust to move the craft. Pushing the throttle/shift lever forward increase engine speed and therefore craft speed.

WARNING

Whenever an engine is to be started, the operator and passengers should always be sitting in the craft with the throttle/shift lever in neutral position.

Throttle/Shift Lever

FORWARD

The throttle/shift lever should be in the forward position in order for the craft to advance.

To obtain forward, depress throttle/shift lever button then gradually push lever to increase craft speed.



FORWARD FULL THROTTLE POSITION

1. Throttle/shift lever button

NEUTRAL

To obtain neutral, pull throttle/shift lever halfway until it locks. The reverse gate will be in the middle position, directing half of the thrust toward the front of the craft to minimize craft movement.

⚠ WARNING
 When the craft is in neutral position, the impeller is turning.



NEUTRAL POSITION

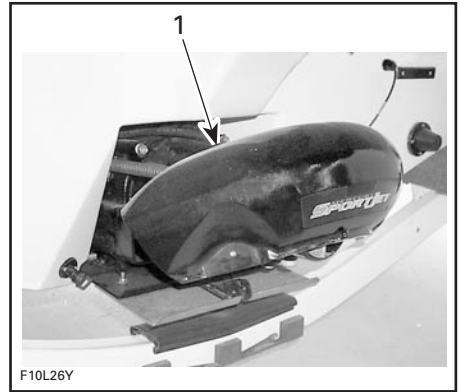

TYPICAL

1. Reverse gate in middle position

REVERSE

To obtain reverse, depress throttle/shift lever button then gradually pull lever. The reverse gate will be in downward position, directing all the thrust toward the front of the craft.



REVERSE FULL THROTTLE POSITION

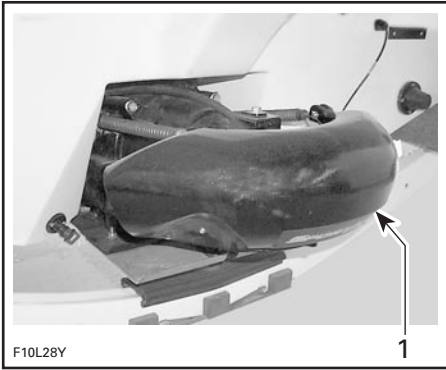

TYPICAL

1. Reverse gate in downward position

NOTE: To obtain maximum efficiency and control from the reverse, increase engine speed to slightly above idle. Too much RPM will create water turbulence and reduce reverse efficiency. In reverse position, turn the steering wheel in the opposite direction that you want to move the rear of the craft. For example, to steer the rear of the craft to the left side, turn the steering wheel to the right side.

Steering

Turning the steering wheel pivots the jet pump nozzle which controls the craft direction. Turning the steering wheel clockwise will turn the craft to the right and inversely.

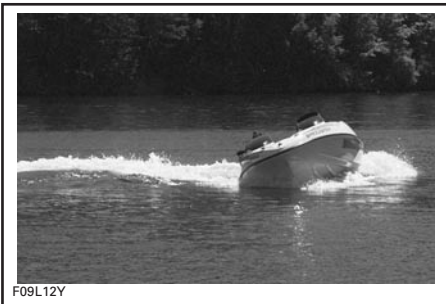

TYPICAL

Above idle speed, the throttle must be applied to turn the craft.

⚠ WARNING

Throttle must be applied and steering turned to change the direction of the craft at speed. Steering efficiency will differ depending on the number of passengers, load and water conditions.

A craft needs some throttle to turn. Practice in a safe area applying the throttle and turning away from an imaginary object. This is a good collision avoidance practice.

Low-Speed Steering Control System

Whenever the engine RPM is at **IDLE AND** the steering wheel is approaching the end of its rotation, the engine speed will be slightly accelerated to increase the jet pump thrust. This helps steering control for low-speed navigation or when approaching/leaving a dock. For docking tips, refer to **STOPPING/ DOCKING** section below.

⚠ WARNING

Become fully familiar with this feature during your first ride and before carrying passengers.

Boarding from a Dock

As with any craft, boarding should be done carefully and engine should not be running.

When boarding from a dock, slowly place one foot on the craft deck nearest to the dock and then move the other foot inside the craft. Push the craft away from the dock.



TYPICAL

CAUTION: Engine should be started with at least 90 cm (3 ft) of water below the hull.

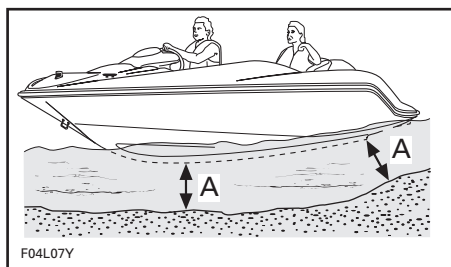

TYPICAL

A. 90 cm (3 ft)

Boarding from the Water

WARNING

Inexperienced riders should practice how to get aboard close to shore first before venturing into deep water.

WARNING

Engine should not be running while boarding. Never use propulsion components as a supporting point to board the craft.

Swim to the rear of the craft.

Come close to rear of craft then unlatch and slide ladder toward rear. Grip swim platform grab handles.



TYPICAL

Climb the ladder and pull yourself upward using the swim platform grab handles.



TYPICAL

When you can reach the engine cover grab handle, grip it and continue to pull yourself upward to place one of your feet on the swim platform.



TYPICAL

Continue to climb on engine cover and go down on the deck.



TYPICAL

To store ladder, lift horizontally completely then slide toward front.

CAUTION: Do not leave ladder hanging when operating the boat. Before operating the craft, always lock the ladder using the latch.

⚠ WARNING

Do not start engine until all passengers are properly seated.

Starting

Always activate bilge blower 5 minutes minimum before starting the engine. The bilge blower will ventilate the bilge.

⚠ WARNING

Bilge blower must be turned off above idle speed.

⚠ WARNING

Do not touch electrical parts or jet pump area when engine is running.

Attach the safety lanyard to your PFD and snap the cap to its switch before starting the engine.

⚠ WARNING

Before starting, the operator and passengers should always be properly seated.

Grip steering wheel with your right hand and place both feet on the floorboard. Turn off bilge blower.

Starting Procedure

Refer to *M² Jet Drive Operator's Guide* for complete detailed procedure.

Rough Water or Poor Visibility Operation

Avoid operation in these conditions. If you must do so, proceed with caution and prudence using minimum speed. Turn on navigation lights if necessary.

Crossing Waves

Reduce speed. Always be prepared to steer and balance as necessary.

When crossing wakes, always keep a safe distance from boat ahead.

⚠ WARNING

When crossing wakes, slow down. Operator and passenger(s) can brace themselves by posting. Do not jump waves or wakes.

Stopping/Docking

The craft is slowed by water drag. The stopping distance will vary depending on the craft size, weight, speed, water surface condition, presence and direction of wind and current.

The operator should become familiarized with the stopping distance under different conditions.

Reduce speed to idle. Shift to neutral, reverse or forward as required.

WARNING

Directional control is reduced with decreasing speed and lost when engine is off.

Low-Speed Steering Control System

Reducing RPM to IDLE activates the low-speed steering control feature as described previously. For more details, refer to LOW-SPEED STEERING CONTROL SYSTEM in TURNING section above.

WARNING

Become familiar with this feature during your first ride.

Beaching

CAUTION: It is not recommended to run the craft to the beach.

Come slowly to the beach and shut off the engine using the safety lanyard when water depth is 90 cm (3 ft) under the hull, then pull the craft to the beach. Ensure that all accessories are OFF.



A. 90 cm (3 ft) of water under the hull

WARNING

In shallow water, shells, sand, pebbles or other objects could be drawn up by the jet pump and be thrown rearward and could damage the engine.

As necessary, the cooling system of the engine should be flushed before re-starting, to remove sand or shell accumulation which may clog the water passages. Refer to POST-OPERATION CARE and look for COOLING SYSTEM FLUSHING.

Shutting Off the Engine

Refer to *M² Jet Drive Operator's Guide*.

WARNING

Should the engine be stopped, craft directional control is lost. Always disconnect safety lanyard when craft is not in operation in order to prevent accidental engine starting or to avoid unauthorized use by children or others or theft.

POST-OPERATION CARE

WARNING

Allow engine to cool before performing any maintenance.

General Care

Should water be present in the bilge after use of bilge pump, unscrew the drain plug and tilt the craft to the rear in order to allow water to drain.

Wipe up any remaining fluid in the engine compartment (bilge, engine, etc.) with clean dry rags. This is particularly important in salt water use.

Remove the craft from the water every day to prevent marine organisms growth.

Additional Care for Foul Water or Salt Water

When the craft is operated in foul water and particularly in salt water, additional care must be taken to protect the craft and its components. Rinse trailer and craft's hull/bilge area with fresh water.

CAUTION: Failure to perform proper care such as: craft rinsing, cooling system flushing and anticorrosion treatment, when used in salt water, will result in damage to the craft and its components. Never leave the craft stored in direct sunlight.

Cooling System Flushing

General

Flushing the cooling system with fresh water is essential to neutralize corroding effects of salt or other chemical products present in water. It will help to remove sand, salt, shells or other particles in water jackets (engine, exhaust manifold, tuned pipe) and/or hoses.

Flushing should be performed when the craft is not expected to be used further the same day or when the craft is stored for any extended time.

WARNING

Perform this operation in a well ventilated area.

Flushing

1. Clean jet pump by spraying water in its inlet and outlet and then apply a coating of Bombardier lube lubricant or equivalent.
2. Open engine cover.
3. Connect a garden hose directly to the flushing connector. **Do not open the water tap yet.**

Refer to *M² Jet Drive Operator's Guide* for complete engine flushing procedure.

SPECIAL PROCEDURE

Engine Overheating

CAUTION: If the monitoring beeper continuously sounds, **stop engine immediately.**

Refer to *M² Jet Drive Operator's Guide*.

If engine still overheats, refer to an authorized SEA-DOO sport boat dealer for servicing.

Jet Pump Water Intake and Impeller Cleaning

Weeds, shells or debris can get caught on the intake grate, drive shaft and/or impeller. A clogged water intake may cause troubles such as:

1. **Cavitation:** Engine speed is high but craft moves slowly due to reduced jet thrust; jet pump components may be damaged.
2. **Overheating:** Since the jet pump operation controls the flow of water to cool the engine, a clogged intake will cause the engine to overheat and damage engine internal components.

The clogged area can be cleaned as described in *M² Jet Drive Operator's Guide*.

WARNING

Always remove safety lanyard cap from switch to prevent accidental engine starting before cleaning the jet pump area.

CAUTION: Avoid craft operation in weeded areas. If unavoidable, vary craft speed. Weeds tend to entangle more at steady and slow speeds. Inspect water intake grate for damage. Refer to an authorized SEA-DOO sport boat dealer for repair as necessary.

Capsized Boat

The boat is designed so that it should not turn over easily due to its length and width. If the boat ever capsizes, remember that it will continue to float, and it is usually best to remain with it, you will be more easily located by others.

WARNING

When boat is capsized, do not attempt to restart the engine. Operator and passengers should always wear approved personal flotation devices.

Submerged Boat

WARNING

DO NOT attempt to restart engine. See an authorized SEA-DOO sport boat dealer as soon as possible to service the engine.

Water Flooded Engine

In the event the engine cannot be serviced within a few hours, remove spark plug cables and connect them on the grounding device.

WARNING

Never crank engine with spark plugs removed unless spark plug cables are connected to the grounding device.

Remove spark plugs and dry them with a clean and dry cloth.

Cover spark plug holes with a rag.

Ensure choke lever is completely pushed in.

Crank engine for approximately 10 seconds to allow water to escape from spark plug openings.

Spray BOMBARDIER LUBE lubricant or equivalent into spark plug holes.

Crank engine again.

Reinstall spark plugs.

Start engine normally.

Low-Charge Battery Condition



WARNING

See your authorized SEA-DOO sport boat dealer to have it charged or replaced. Do not charge or boost the battery while installed on the craft. Electrolyte is dangerous and capable of causing severe burns.

MAINTENANCE

WARNING

Only perform procedure as detailed in this guide. It is recommended that the assistance of an authorized SEA-DOO sport boat dealer be periodically obtained on other components/systems not covered in this guide and/or *M2 Jet Drive Operator's Guide*. Unless otherwise specified, engine must not be running and the main battery cut-off switch must be turned OFF for all maintenance procedures.

Lubrication

Anticorrosion Protection

Throttle Cable

Lubricate the throttle cable with BOMBARDIER LUBE lubricant or equivalent, every 25 hours of use (every 10 hours in salt water use).

Electrical Connections

As necessary, apply dielectric grease on battery posts and all exposed cable connectors including stern light connectors on mat and craft.

Additional Lubrication

BOMBARDIER LUBE lubricant or equivalent will help to prevent corrosion and maintain proper operation of moving mechanisms.

Lubrication of the following items should be performed every 50 hours in fresh water use but every 10 hours in salt water use.

Engine Cover Hinges

Use BOMBARDIER LUBE lubricant or equivalent on metal parts.

Engine Cover Cylinders

Lubricate rod of cylinders.

Periodic Inspection

Routine maintenance is necessary for all mechanized products. A periodic inspection contributes to the products life span.

The following maintenance chart gives guidelines for regular craft servicing schedule to be performed by you and/or by an authorized SEA-DOO sport boat dealer. The schedule should be adjusted according to operating conditions and use.

Periodic Inspection Chart

DESCRIPTION	FREQUENCY				TO BE PERFORMED BY
	FIRST 10 HOURS	EVERY 25 HOURS	EVERY 50 HOURS	EVERY 100 HOURS OR SEASONALLY	
Lubrication/corrosion protection			✓		OPERATOR
Lubrication of locks	①		✓		OPERATOR
Safety lanyard cap				✓	DEALER
Throttle/shift lever cables operation/lubrication	①	✓			OPERATOR
Throttle/shift lever cables adjustments				✓	DEALER
Fuel filter inspection		✓			DEALER
Fuel filter replacement				✓	DEALER
Steering system and low-speed steering control system			✓		DEALER
Throttle/shifter system				✓	DEALER
Muffler, battery and reservoir fastening devices			✓		DEALER
Fuel/oil line, hose inspection	✓	✓	✓	✓	DEALER
Bilge pump/deck drain/scupper valve inspection			✓		OPERATOR
Battery condition			✓		DEALER
Starter cables		✓			DEALER
Monitoring beeper/electrical connections			✓		DEALER
Hull condition and ride shoes				✓	DEALER
Cooling system flushing ②		✓			OPERATOR
Navigation lights condition		✓			DEALER
Sacrificial aluminum anode(s)			✓		OPERATOR
Bilge blower inspection			✓		DEALER

NOTE: Some items are included in the PRE-OPERATION CHECKS and are not necessarily mentioned in this chart but must also be done. Refer to *M² Jet Drive Operator's Guide* for engine and jet pump checks.

① Every 10 hours in salt water use.

② Daily flushing in salt water or foul water use.

Throttle/Shift Lever Cable

Activate the throttle/shift lever throughout its full range of motion. It must operate smoothly. Refer to an authorized SEA-DOO sport boat dealer if adjustment is necessary.

WARNING

Do not alter or tamper with throttle/cable adjustment or routing.

Fuel and Oil Filters

These filters should be replaced by an authorized SEA-DOO sport boat dealer annually.

Refer to *M² Jet Drive Operator's Guide*.

Steering/Jet Pump Nozzle Adjustment

When the steering is directed in straight ahead position, the jet pump nozzle should be in the same direction to allow the craft to run in a straight line.

Refer to an authorized SEA-DOO sport boat dealer if an adjustment is necessary.

WARNING

Ensure the steering/jet pump nozzle operate freely from side to side and is not stressing the steering cable.

Reverse Gate

WARNING

Ensure the throttle/shift lever and reverse gate operate freely and are not stressing the reverse cable.

Refer to an authorized SEA-DOO sport boat dealer if an adjustment is necessary.

Deck Drain(s)

Remove any obstruction from deck drain.

Fuses

Accessories, Craft Electrical System and Gauges

If a fuse is defective, replace by one of the same rating.

WARNING

Do not use a higher rated fuse as this can cause severe damage. If a fuse has burnt out. Source of malfunction should be determined and connected before restarting. See an authorized SEA-DOO sport boat dealer for servicing.

Engine

Refer to *M² Jet Drive Operator's Guide*.

Bilge Air Blower

Verify bilge air blower for proper operation. It is located inside engine compartment beneath ventilation duct.

Clean both openings. Ensure that both openings are not obstructed. See next illustration.

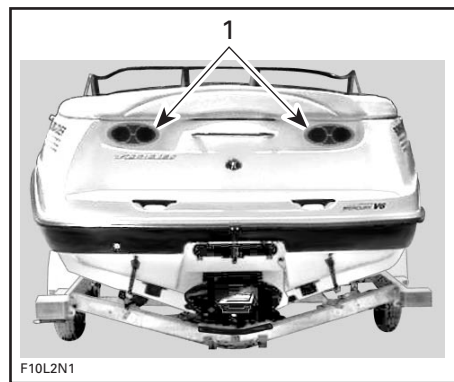

1. Bilge ventilation ducts

WARNING

If bilge blower does not operate refer to an authorized SEA-DOO sport boat dealer before starting the craft.

Navigation Light Bulb Replacement

Bow Light

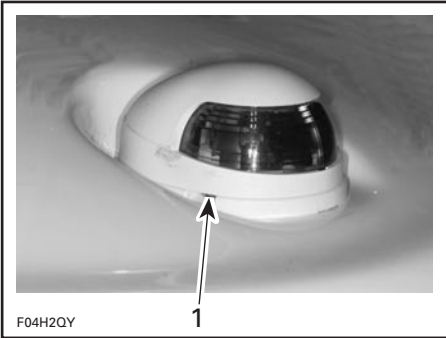

TYPICAL
1. Gently pry here with a screwdriver

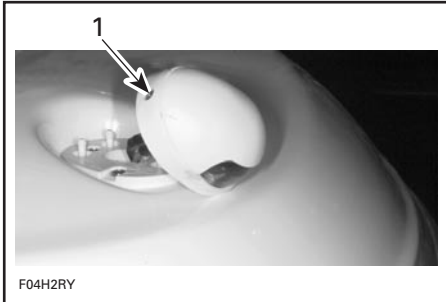

TYPICAL
1. Remove this screw

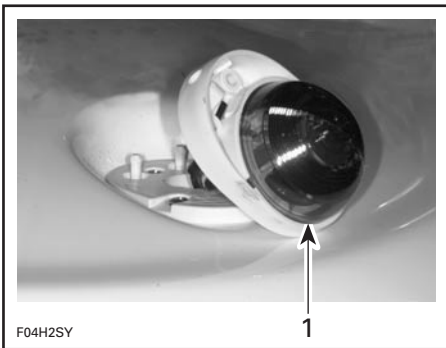

TYPICAL
1. Pull lens out

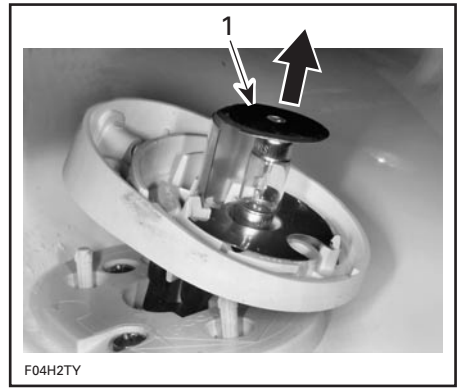

TYPICAL
1. Lift and remove bulb

The assembly is essentially the reverse of removal procedures. However, pay particular attention to the following:

Apply dielectric grease on bulb contact surface.

When installing the bulb under the upper terminal plate, it is possible that the bulb remains loose. The cover will compress the terminal plate against the bulb at reinstallation.

Stern Light

Unscrew lens counterclockwise and pull it out.

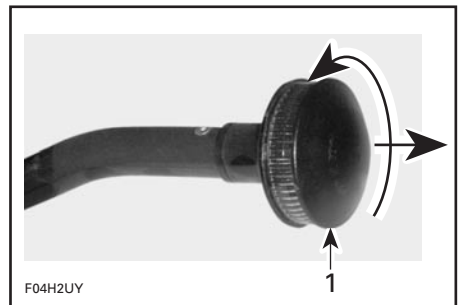

1. Unscrew then pull

Pull bulb to remove it.

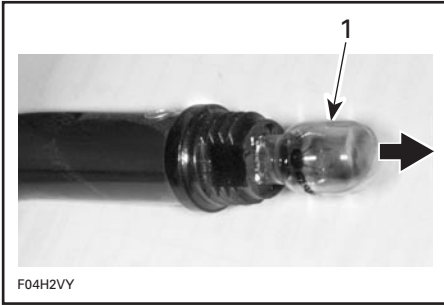

1. Pull bulb out

Apply dielectric grease on new bulb contact surface.

The assembly is the reverse of removal procedure.

General Inspection and Cleaning

Inspection

Check engine compartment for any damage. Ensure all hose clamps are properly secured and no hose is cracked, kinked or presenting any other damage.

WARNING

If any gasoline leak and/or odors are present, do not start the engine. Have the craft serviced by an authorized SEA-DOO sport boat dealer.

Inspect muffler, battery, fuel tank and oil reservoir fastening devices. Visually check electrical connections for corrosion and tightness.

Inspect hull and jet pump water intake grate for damage. Replace or have damaged parts repaired.

Cleaning

The bilge should be cleaned by the dealer to remove any possible fuel/oil/electrolyte deposits and mildew.

Occasionally, wash the body with hot water and soap (only use mild detergent). Remove any marine organisms from engine and/or hull. Apply non-abrasive wax.

CAUTION: Never clean fiberglass and plastic parts with strong detergent, degreasing agent, paint thinner, acetone, etc.

Wash windscreen with Bombardier cleaner or equivalent (P/N 293 110 001 — 400 g) and water. For fine scratches and scuff marks removal, use a windshield polisher for acrylic, lucite, polycarbonate and similar materials.

Stains may be removed from seats and fiberglass with Knight's Spray-Nine* from Korkay System Ltd or the equivalent.

Respect the environment by ensuring fuel, oil or cleaning solutions do not drain into the waterways.

STORAGE AND PRE-SEASON PREPARATION

WARNING

Because fuel and oil are flammable, have an authorized SEA-DOO sport boat dealer inspect the fuel and oil systems integrity as specified in the periodic inspection chart.

Storage

It is recommended that the craft be taken to an authorized SEA-DOO sport boat dealer for proper storage but the following operations can be performed by you with a minimum of tools.

CAUTION: Do not run the engine during the storage period.

Fuel System

Refer to *M² Jet Drive Operator's Guide*.

Cooling System Flushing and Engine Internal Lubrication

Refer to *M² Jet Drive Operator's Guide*.

Propulsion System

Refer to *M² Jet Drive Operator's Guide*.

Craft Cleaning/Repair

Wash the body and the trailer with soap and water solution (only use mild detergent). Rinse thoroughly with fresh water. Remove any marine organisms from the hull.

CAUTION: Never clean apparent fiberglass and plastic parts with strong detergent, degreasing agent, paint thinner, acetone, etc.

Stains may be removed from seats and fiberglass with Knight's Spray-Nine* from Korkay System Ltd or the equivalent.

If repairs are needed to the body or to the hull contact your dealer. For paint touch up to mechanical parts use Bombardier spray paint. For minor gelcoat repairs, a Bombardier repair kit is available. Replace damaged labels/decals.

Clean the bilge with hot water and detergent or with bilge cleaner. Rinse thoroughly. Unscrew drain plug(s) and lift front end of craft to completely drain bilge.

Battery

Contact your authorized SEA-DOO sport boat dealer.

Anticorrosion Treatment

Wipe off any residual water in the engine compartment.

Lubricate the throttle cable with BOMBARDIER LUBE lubricant or equivalent.

Finalizing Storage Preparation

Apply a non abrasive wax to body.

The engine cover should be left partially opened during storage (detach the gas shocks from the cover to prevent full opening). Remove storage tray. Place it on deck. This will avoid engine compartment condensation and possible corrosion.

If the craft is to be stored outside, cover it with a vented opaque tarpaulin to prevent sun rays and grime from affecting the plastic components, craft finish as well as preventing dust accumulation.

CAUTION: Never leave the craft stored in direct sunlight. UV radiation will dull finishes. The craft must never be left in water for storage. Make sure to turn off main battery cut-off switch.

During storage, it is necessary to lift the bow up and safely block in this position so drainage can take place. Ensure the drain plug is unscrewed.

Pre-Season Preparation

Use the following chart.

Since technical skills and special tools are required, some operations should be performed by an authorized SEA-DOO sport boat dealer.

WARNING

Only perform procedure as detailed in this guide. It is recommended that the assistance of an authorized SEA-DOO sport boat dealer be periodically obtained on other components/systems not covered in this guide and/or *M² Jet Drive Operator's Guide*. Unless otherwise specified, engine must not be running and the main battery cut-off switch must be turned OFF for all maintenance procedures.

Pre-Season Preparation Chart

NOTE: It is highly recommended that the dealer perform at the same time the annual safety inspection in addition to the pre-season preparation.

OPERATIONS	TO BE PERFORMED BY
Lubrication/corrosion protection	OPERATOR
Safety lanyard cap condition	DEALER
Battery condition/charging and reinstallation	DEALER
Starter connections and routing ①	DEALER
Oil reservoir filling	OPERATOR
Fuel filter replacement	DEALER
Fuel line condition ①	DEALER
Filler neck, fuel tank and fuel cap condition ①	DEALER
Check fuel system fasteners	DEALER
Steering system and low-speed steering control system inspection ①	DEALER
Throttle/shifter system inspection ①	DEALER
Inspection of deck drains/bilge pump/drain plugs	DEALER
Fire extinguisher condition/mounting ①	OPERATOR

① Safety item covered in the annual safety inspection.

CAUTION: Only perform this operation in a well ventilated area. Garden hose must be installed or craft must be in water to cool engine. Running the engine without cooling water will damage exhaust hose interior and may damage engine.

SPECIFICATIONS

ENGINE		UTOPIA 185	UTOPIA 205
Number of engines		1	
Engine options		200 Opti, 210 carb, 240 EFI Plus, 250 Optimax	
Engine type		Mercury Marine V-6, 2 stroke	
Maximum engine power capacity rating		150 kW (200 HP) @ 5650 RPM 157 kW (210 HP) @ 5750 RPM 179 kW (240 HP) @ 6250 RPM 186 kW (250 HP) @ 5850 RPM	
Induction type		Reed valve	
Exhaust system	Type	Mercury Marine, 2 mufflers	
Starting system		Electric start	
Low-speed RPM adjustment		1800 RPM	
Lubrication	Fuel/oil mixture	Refer to M² Jet Drive specifications	
	Oil injection pump		
	Oil type		
Number of cylinders		6	
ADDITIONAL INFORMATION: Refer to M² Jet Drive specifications for more detailed information.			

ELECTRICAL		UTOPIA 185	UTOPIA 205
Ignition system type		Digital-CDI (Capacitor Discharge Ignition) Digital Inductive (200 Opti)	
Spark plug	Make and type	Refer to M² Jet Drive specifications	
	Gap		
Starting system		Electric starter	
Battery		Not supplied ①	
Fuse	Deck (courtesy) lights	1 A (2)	
	Bilge air blower	7.5 A	
	Bilge pump	7.5 A	
	Navigation lights	3 A	
	Gauges/low fuel	3 A	
	Radio	5 A	
	Horn system	5 A	
12-volt jack system		10 A	

ADDITIONAL INFORMATION:

① Recommended: See **Mercury Marine recommendations**.

Battery posts: On top. Round taper type.

Battery maximum allowed size: 267 mm (10-1/2 in) long x 172 mm (6-3/4 in) wide x 238 mm (9-3/8 in) high.

CARBURETION	UTOPIA 185	UTOPIA 205
Refer to M² Jet Drive specifications for more detailed information.		

COOLING	UTOPIA 185	UTOPIA 205
Type	Open circuit — Direct water flow	

PROPULSION	UTOPIA 185	UTOPIA 205
Propulsion system	Mercury Marine Sport Jet	
Number of pumps	1	
Jet pump type	Mixed flow, single stage	
Steering nozzle pivoting angle	26°	
Minimum required water level	90 cm (36 in)	
Refer to M² Jet Drive specifications for more detailed information.		

DIMENSION	UTOPIA 185	UTOPIA 205
Dead rise	20°	
Draft	30.5 cm (12 in)	
Overall length	5.56 m (18 ft 3 in)	5.91 m (19 ft 5 in)
Overall width (beam)	2.44 m (8 ft)	
Dry weight	930 kg (2050 lb) with 200 Optimax/210 Carb 957 kg (2110 lb) with 240EFI Plus/250 Optimax	1029 kg (2270 lb) with 210 Carb 1056 kg (2330 lb) with 240 EFI Plus/250 Optimax
Load limit (passengers + luggage)	8 passengers or 600 kg (1320 lb) (based on calm water operation)	

CAPACITIES	UTOPIA 185	UTOPIA 205
Fuel tank (including reserve)	151 L (40 U.S. gal)	
Main injection oil reservoir	11 L (3 U.S. gal)	

MATERIALS	UTOPIA 185	UTOPIA 205
Hull	Composite (fiberglass and balsa)	
Fuel tank	Polyethylene	
Injection oil reservoir	Polyethylene	
Seat	Base: Polyethylene Foam: Polyurethane	
Windshield	Tinted, tempered glass	

SI* METRIC INFORMATION

BASE UNITS			
DESCRIPTION	UNIT	SYMBOL	
length	meter	m	
mass	kilogram	kg	
force	newton	N	
liquid	liter	L	
temperature	Celsius	°C	
pressure	kilopascal	kPa	
torque	newton-meter	N•m	
land velocity	kilometer per hour	km/h	
navigation velocity	knot	kn	

PREFIXES			
PREFIX	SYMBOL	MEANING	VALUE
kilo	k	one thousand	1000
centi	c	one hundredth of	0.01
milli	m	one thousandth of	0.001
micro	μ	one millionth of	0.000001

CONVERSION FACTORS			
TO CONVERT	TO ①	MULTIPLY BY	
in	mm	25.4	
in	cm	2.54	
in ²	cm ²	6.45	
in ³	cm ³	16.39	
ft	m	0.3	
oz	g	28.35	
lb	kg	0.45	
lbf	N	4.4	
lbf•in	N•m	0.11	
lbf•ft	N•m	1.36	
lbf•ft	lbf•in	12	
PSI	kPa	6.89	
imp. oz	U.S. oz	0.96	
imp. oz	mL	28.41	
imp. gal	U.S. gal	1.2	
imp. gal	L	4.55	
U.S. oz	mL	29.57	
U.S. gal	L	3.79	
knot	MPH	1.15	
MPH	km/h	1.61	
Fahrenheit	Celsius	(°F - 32) ÷ 1.8	
Celsius	Fahrenheit	(°C x 1.8) + 32	
hp	kW75	

* The international system of units abbreviates SI in all languages.

① To obtain the reverse sequence, divide by the given factor. Example: to convert millimeters to inches, divide by 25.4.

NOTE: Conversion factors are rounded off to 2 decimals for easier use.



DECLARATION **CE** OF CONFORMITY

Application of Council Directives: 94/25/CE — Recreational craft
89/336/CEE — Electromagnetic compatibility

Standards to which conformity is declared: ISO 7840, ISO 8469, ISO 8665, ISO 8846,
ISO 8848, ISO 8849, ISO 9094, ISO 9097,
ISO 10087, ISO 10088, ISO 10133, ISO 10240,
ISO 11105, ISO 11591, ISO 11592, ISO 12215,
ISO 12216, ISO 13592, COLREGS, ABYC H-5,
ABYC H-8

Manufacturer's name: Bombardier Motor Corporation of America.

Manufacturer's address: 451 E. Illinois Ave
Benton, Illinois
62812-0394

Importer's name: Société ANF — Industrie S.A.

Importer's address: 2, rue du Nouveau Bercy
94220 Charenton
Paris, France

Notified body for Directive 94/25/CE: International Marine Certification Institute
Trèves centre, rue de Trèves 45
1040 Brussels, Belgium

Competent body for Directive 89/336/CEE: UTAC
Autodrome de Linas-Montlhéry, B.P. 212
91311 Montlhéry cedex, France

Type of equipment: Sport boats, inshore category C

Model names:

Model name

Model number(s)

I, the undersigned, hereby declare that the equipment specified above conforms to the above Directives and Standards.

Name of signatory: Fernando Garcia

Title of signatory on behalf of
Bombardier Motor Corporation of America: Director - Public and Regulatory Affairs —
Sea-Doo sport boats

Homologation and Certification

These boats comply with the following standards:

STANDARD	TYPE OF CERTIFICATION
United States Coast Guard	Self certification
Canadian Coast Guard	Self certification
Russian Maritime Register of Shipping	Certify by Russian Maritime Register of Shipping 8, Dvortsovaya Nab., 191186 St. Petersburg, Russia
Directive 89/336/CEE of the council relating to electromagnetic compatibility	Internal production control plus control carried out on the responsibility of a competent body. Competent body: UTAC Autodrome de Linas-Montlhéry, B.P. 212 91311 Montlhéry cedex, France
Directive 94/25/EC of the European Parliament and of the council relating to recreational craft	Internal production control plus control carried out on the responsibility of a notified body. Notified body: International Marine Certification Institute Trèves centre, rue de Trèves 45 1040 Brussels, Belgium

Operator's Guide Confirmation of Receipt

Your dealer

Name:	_____

Address:	_____

Will assist you and help you to resolve any problems you may have.

Upon delivery of your sport boat, complete and sign the form hereunder and forward it to your dealer in order to be covered by our warranty.

Warranty conditions are as detailed in the Warranty Section of this guide.

----- Cut here

Receipt	
Name:	_____
Address:	_____
Owner of _____	Sport Boat _____
HIN (to be completed by customer or selling dealer) _____	
This warranty begins _____ (date).	
The dealer named on this document has instructed me on the operation, maintenance, safety features and warranty policy, all of which I understand and agree to be bound with. I am also satisfied with the predelivery set-up and inspection of my Sea-Doo sport boat. I have also received a copy of the <i>Operator's Guide, Safety Handbook and Safety Videocassette</i> for my Sea-Doo sport boat.	
Signature:	_____
Date:	_____

PRIVACY INFORMATION

We wish to inform you that your coordinates will be used for safety and warranty purposes. Sometimes, we also use the coordinates of our clients to inform them about our products and to present them offers. Should you prefer not to receive information on our products, services and offers, please let us know by writing to the address below.

Also note that, from time to time, carefully selected and trustworthy organizations may be permitted to use the coordinates of our clients to promote quality products and services. If you prefer not to have your name and address released, please let us know by writing to the address below:

Bombardier Inc.
Recreational Products
Warranty Department
75 J.A. Bombardier Street
Sherbrooke, Québec J1L 1W3
Canada
Fax Number (819) 566-3590



AFFIX
PROPER
POSTAGE

BOMBARDIER
RECREATIONAL PRODUCTS
WARRANTY DEPARTMENT
75, J.A. BOMBARDIER ST.
SHERBROOKE (QUEBEC)
CANADA J1L 1W3



AFFIX
PROPER
POSTAGE

BOMBARDIER
RECREATIONAL PRODUCTS
WARRANTY DEPARTMENT
75, J.A. BOMBARDIER ST.
SHERBROOKE (QUEBEC)
CANADA J1L 1W3

SPORT BOAT MODEL No. _____

HULL IDENTIFICATION NUMBER (H.I.N.) _____

MERCURY OR ROTAX ENGINE IDENTIFICATION NUMBER (E.I.N.) _____

Owner: _____
NAME

No. STREET APT

CITY STATE/PROVINCE ZIP/POSTAL CODE

Purchase Date _____
YEAR MONTH DAY

Warranty Expiry Date _____
YEAR MONTH DAY

To be completed by the dealer at the time of the sale.

DEALER IMPRINT AREA

Please verify with your selling dealer to ensure your SEA-DOO craft has been registered with Bombardier.

™ © Trademarks of Bombardier Inc. or its subsidiaries.
© 2002 Bombardier Inc. All rights reserved.
Printed in Canada.



SEA·400®
Sport Boats