

# SEA·DOO® JET BOATS

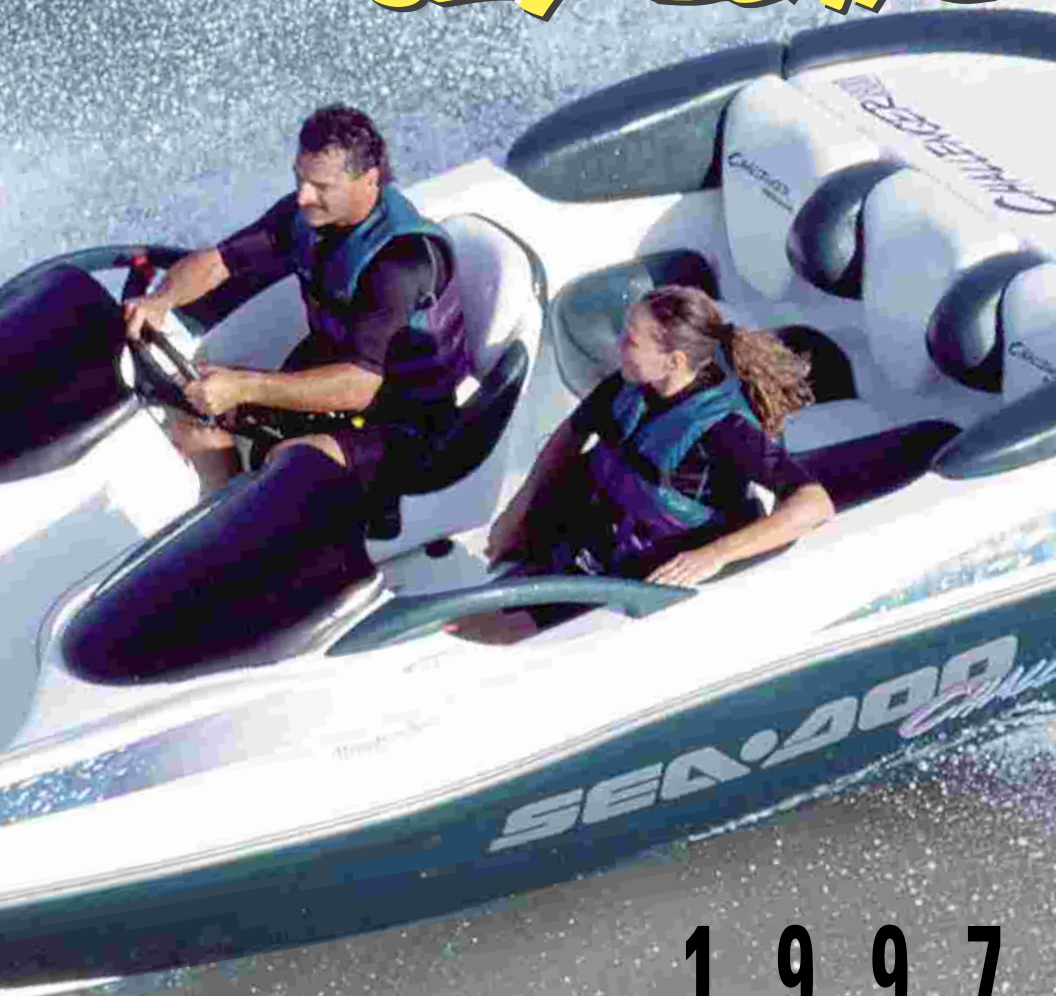

1 9 9 7

OPERATOR'S  
GUIDE

CHALLENGER 1800 5600 / 5601

2 1 9 0 0 0 0 6 9

## **SAFETY WARNING**

Disregarding any of the safety precautions and instructions contained in this *Operator's Guide* and on *Product Warnings* could cause injury, including the possibility of death.

This *Operator's Guide*, the *Safety Handbook* and videocassette should remain with the jet boat at the time of resale.

AFTER-SALES  
SERVICE  
BOMBARDIER INC.  
VALCOURT (QUÉBEC)  
CANADA J0E 2L0



**The following trademarks are property of  
Bombardier Inc.:**

SEA-DOO®

Sea-Doo Lube®

Sea-Doo Jet Pump Synthetic Oil

Sea-Doo Synthetic Grease

Gelcote® is a trademark of Gelcote International

---

## **Doin'it on your new Sea-Doo Jet boat**

Congratulations, you are now the proud owner of a jet boat. Whether you are an experienced boater or are new to the sport of boating, we ask you to take the time to view the *Safety Videocassette* provided with your jet boat, to read this *Operator Guide* and *Safety Handbook* and familiarize yourself with its contents. The guide contains pertinent information which, if followed, will provide you with the necessary knowledge to help you fully enjoy the pleasures of this boat.

We strongly recommend that any boat operator complete a safety boating course. Check with your local Coast Guard or Power and Sail Squadron in your area for course availability. More serious boaters may want to obtain "Chapman Piloting" by Elbert S. Maloney, available at most book stores.

When introducing your family or friends to the sport, be sure they fully understand the controls and operation of the jet boat and the importance of courteous, responsible riding.

Each jet boat operator has a responsibility to ensure the safety of its passengers and other water users. Please follow all safety instruction and drive with care.

We encourage you to have an Annual Safety Inspection of your jet boat. Please contact your dealer for further details.

Finally, we invite you to visit your dealer for regular safety maintenance as well as any boating accessories you may require.

Have fun and.....Bon Voyage.

**Please keep this *Guide* and *Safety Handbook* on board. These manuals should remain with the jet boat at time of resale.**

# TABLE OF CONTENTS

---

<b>FOREWORD</b> .....	<b>5</b>
<b>◆ SAFETY WARNING</b> .....	<b>7</b>
<b>BOMBARDIER LIMITED WARRANTY: 1997 SEA-DOO® JET BOAT</b> .....	<b>10</b>
<b>LIST OF DISTRIBUTORS</b> .....	<b>12</b>
<b>REGISTRATION NUMBER LOCATION</b> .....	<b>13</b>
<b>LOCATION OF THE IMPORTANT LABELS</b> .....	<b>14</b>
<b>IDENTIFICATION NUMBERS</b> .....	<b>16</b>
Hull .....	16
Engines.....	16
<b>CONTROLS AND COMPONENTS LOCATION</b> .....	<b>17</b>
1) Safety Lanyard Post.....	20
2) Steering Wheel .....	21
3) Throttle Levers.....	22
4) Shift Lever.....	22
5) Start/Stop Buttons .....	23
6) Choke Levers .....	24
7) Navigation Light Switch .....	24
8) Bilge Pump Switch.....	24
9) Bilge Blower Switch.....	24
10) Horn Switch .....	25
11) Deck Light Switch.....	25
12) Fuel Reserve Switch .....	25
13) Fuel Gauge/Low Oil Level Pilot Lamp.....	25
14) Tachometers .....	26
15) Speedometer .....	26
16) Fuel Valves.....	26
17) Bilge Drain Plug.....	26
18) Grab Handles .....	27
19) Rear Grab Handle .....	27
20) Swim Platform .....	27
21) Front and Rear Seats .....	27
22) Sun Seat.....	28
23) Sun Deck.....	28
24) Cup Holders .....	28
25) Right Front Storage Compartment.....	28
26) Deck Storage Compartment .....	29
27) Rear Storage Compartment .....	30
28) Glove Box.....	31
29) Left Front Storage Compartment.....	31
30) Jet Pump Water Intakes .....	31

31) Tow Hook.....	31
32) Radio.....	31
33) 12 Volts Accessory Jack.....	32
34) Bow Light.....	32
35) Removable Stern Light.....	32
36) Mooring Cleats.....	33
37) Deck.....	33
38) Fuel Tank Cap.....	33
39) Deck Drain Hole.....	33
40) Oil Injection Tank Cap.....	33
41) Flushing Connectors.....	34
42) Ventilation Ducts.....	34
43) Bow/Stern Eyelets.....	34
44) Jet Pump Nozzles.....	34
45) Sacrificial Zinc Anodes.....	34
46) Reverse Gates.....	34
47) Retractable Ladder.....	34
48) Scupper Valve.....	35
49) Weedless System Lever.....	35
<b>FUEL AND LUBRICATION .....</b>	<b>38</b>
Fueling Procedure.....	38
Recommended Fuel.....	38
Recommended Oil.....	38
Oil Injection System.....	39
<b>BREAK-IN PERIOD .....</b>	<b>40</b>
Engines.....	40
10-Hour Inspection.....	40
<b>PRE-OPERATION CHECKS .....</b>	<b>42</b>
Hull.....	42
Jet Pump Water Intakes.....	42
Bilge.....	43
Battery.....	43
Fuel/Oil Reservoirs.....	43
Engine Compartment.....	43
Fire Extinguisher.....	43
Steering System.....	43
Throttle System.....	43
Shifter System.....	43
Weedless System.....	43
Safety Lanyard and Engine Start/Stop Buttons.....	43
<b>OPERATING INSTRUCTIONS .....</b>	<b>44</b>
Principle of Operation.....	44

Boarding from a Dock or in Shallow Water .....	45
Starting the Engines .....	45
Obstacles.....	47
Boarding in Deep Water .....	47
Rough Water or Poor Visibility Operation .....	48
Stopping/Docking .....	48
Beaching.....	48
<b>POST-OPERATION CARE .....</b>	<b>50</b>
General Care.....	50
Additional Care for Foul Water or Salt Water .....	50
<b>SPECIAL PROCEDURE.....</b>	<b>53</b>
Engine Overheating .....	53
Jet Pump Water Intake and Impeller Cleaning .....	53
Capsized Boat.....	53
Submerged Boat.....	54
Towing the Boat in Water.....	54
Operating the Boat with Only One Engine .....	55
Low-Charge Battery Condition .....	55
<b>MAINTENANCE .....</b>	<b>56</b>
Lubrication .....	56
Periodic Inspection .....	58
Periodic Inspection Chart.....	59
Throttle and Choke Cables .....	60
Fuel and Oil Filters.....	60
Steering/Jet Pump Nozzle Adjustment.....	60
Reverse Gates .....	61
Fuses .....	61
Bilge Blower .....	61
Sacrificial Zinc Anodes.....	62
Navigation Light Bulb Replacement .....	62
General Inspection and Cleaning.....	63
<b>TRANSPORTATION, STORAGE AND PRE-SEASON PREPARATION .....</b>	<b>65</b>
Transportation.....	65
Storage .....	65
Pre-Season Preparation .....	69
<b>TROUBLESHOOTING .....</b>	<b>71</b>
<b>SPECIFICATIONS.....</b>	<b>74</b>
<b>SI METRIC INFORMATION GUIDE.....</b>	<b>76</b>
<b>CHANGE OF ADDRESS.....</b>	<b>79</b>

# FOREWORD

---

The *Operator's Guide* has been prepared to acquaint the owner/operator or passenger of this jet boat with the various jet boat controls, maintenance and safe riding instructions. It is indispensable for the proper use of the product, and should be kept in a waterproof bag in the jet boat at all times.

For any questions pertaining to the warranty and its application, please consult an authorized SEA-DOO jet boat dealer.

This guide uses the following symbols to emphasize particular information.



## WARNING

Identifies an instruction which, if not followed, might cause serious personal injuries including the possibility of death.



## CAUTION

Denotes an instruction which, if not followed, might severely damage the jet boat and/or components.

**NOTE:** Indicates supplementary information needed to fully complete an instruction.

Although the mere reading of such information does not eliminate the hazard, the understanding and application of the information will promote its correct use.

The information and components/system descriptions contained in this document are correct at the time of publication. Bombardier Inc. however, maintains a policy of continuous improvement of its products without imposing upon itself any obligation to install them on products previously manufactured. Due to late changes, it may have some differences between the manufactured product and the descriptions and/or specifications in this document. Bombardier Inc. reserves the right at any time to discontinue or change specifications, designs, features, models or equipment without incurring obligation.

The illustrations in this document show the typical construction of the different assemblies and may not reproduce the full detail or exact shape of the parts. However, they represent parts that have the same or similar function.

It is understood that this guide may be translated into another language. In the event of any discrepancy, the English version shall prevail.

Specifications are given in the SI metric system with the SAE U.S. equivalent in parenthesis. Where precise accuracy is not required, some conversions are rounded off for easier use.

---

A *Shop Manual* can be obtained for complete service, maintenance and more repair information.



## **WARNING**

The engines and the corresponding components identified in this guide should not be utilized on product(s) other than those they were designed for. Maintenance procedures and specified tightening torques must be strictly adhered to. Never attempt repairs unless the appropriate tools are available. This jet boat is designed with parts dimensioned in both the metric and the imperial systems. When replacing fasteners, make sure to use only those recommended by Bombardier. Mismatched or incorrect fasteners could cause damage to the jet boat or possible personal injury.

**NOTE:** The following list gives the equivalent of terms commonly used to designate boat references.

Port: LH side

Starboard: RH side

Bow: Front

Stern: Rear



## ◆ SAFETY WARNING

---

To fully appreciate the pleasures, enjoyment and excitement of boating there are some basic rules that **MUST** be observed and followed by any boater. Some rules may be new to you while others may be common sense or obvious, irrespective, we ask that you please take a few minutes of your time to read these safety instructions completely before you operate your boat. **Failure to follow this safety information and safe boating rules could result in injury, including the possibility of death to you, your passenger(s), or other water users.**

Information in this guide is limited. It is strongly recommended that you obtain further boating information from the local Coast Guard or Power Squadron. We further recommend you take a safe boating course. Check local and federal boating laws applicable to the waterways where you intend to use the boat. Learn the local rules of the road.

Become completely familiar with the controls and operation of the boat before taking on a passenger(s) or embarking on a trip. If you have not had the opportunity to do so with your dealer, practice driving solo in a suitable area and feel the response of each control. Start, accelerate then stop using one then both engines. Be fully familiar with all controls before fully pushing the throttles.

The performance of this jet boat may significantly exceed that of other jet boats you may have operated. Therefore, use of this jet boat by a novice or inexperienced operator is not recommended.

Observe and follow all on-product warning labels and the content of this guide.

An operator and passenger(s) should wear suitable eye and body protection as well as deck shoes or booties.

Coast Guard approved personal flotation devices (PFD) must be worn by all aboard.

Operation of this boat by a minor or disabled person is **NOT** recommended.

Do not operate the boat after consuming alcohol or drugs.

Store or tie-down any loose articles or necessary boating equipment before operating the boat.

Always perform the pre-operation checks as specified in this guide. This includes:

- Attaching the safety lanyard to your PFD.
- Verification of throttle levers, shifter and steering movement.
- Verification of start/stop button operation.
- Oil and fuel levels.
- Use of blower.
- Adequate water depth.
- Functional navigation lights.
- Required boating equipment. (Know how to use each).

The operator and passenger(s) must be properly seated in their designated seats before starting or moving the boat. Do not permit a passenger to use the sun seat except in calm waters and at very low speeds. Never allow anyone to sit on the sun deck or boarding platform while the boat is operational. Allow no one to jump into the boat at anytime, or move during boat operation. The risk of an accidental fall or slip is always present.

Ensure operator all-round visibility is unrestricted.

While the engines can be stopped by depressing the start/stop buttons, good habit recommends that the safety lanyard be used to stop the engines at all times.

---

Wave or wake jumping can be dangerous and in many regions illegal.

Most boating accidents occur as a result of the failure of the operator to keep a lookout for other water users or other potential hazards. Keep a safe distance from other boats or watercraft. Do not attempt to splash others with your wake. Do not ride the surf line.

This boat is equipped with navigation lights which should be used between sunset and sunrise. Lower speed and do not operate the boat in reduced visibility. This boat is not equipped with spot-lights.

To prevent accidental starting or unauthorized use, always detach the safety lanyard from the boat especially during maintenance, cleaning of the intake grates, or when swimmers are nearby.

Ensure that all passengers know how to reboard the boat from the water.

Always have an observer while towing a skier.

Know the waters in which the boat is to be operated. Current, tides, rapids, shallow water, hidden obstacles etc., can effect safe operation.

When boating, apply the principle of 1/3 fuel to destination, 1/3 back and 1/3 reserve fuel supply.

Maintain the boat and equipment in top condition at all times. Adhere to the prescribed maintenance schedules.

The bilge must be kept clean of oil, water or other foreign materials. Do not carry spare fuel and inflammable liquids in any of the storage or engine compartments.

Avoid adding on accessories, carrying equipment or passengers which may alter the boat's configuration or balance.

Only perform servicing procedures which are detailed in this guide. Further assistance or information can be obtained from your dealer. In many instances proper tools and training is required for certain servicing or repair procedures.

Gasoline fumes are flammable and explosive. Always adhere to the fueling and starting procedures contained in this guide and those given to you by the marina.

This boat has the capability of turning more sharply than other boats, however, unless in an emergency, do not negotiate sharp, high speed turns.

Like any other boat, this boat has no brake. Stopping distance will vary depending on initial speed, load, wind, and water conditions. Practice stopping and docking in a safe area to have an idea of how long it will take to stop the boat under varying conditions.

Prolonged exposure to the sun, wind etc., causes fatigue and may affect your reaction time.

Do not overload the boat or take on more passengers than designated for the intended type of boating. Load and altitude will also affect boat performance.

Proceed with caution and at very low speeds in shallow water. Grounding or abrupt stops may result, or debris may be picked up and be jettisoned rearward towards people or property. The impellers are turning even when the shift lever is at neutral.

As the "skipper" of a boat you are responsible for damage to other boats and property caused by the wake of your boat. Respect no wake zones.

Respect the rights of other water users and the environment. Allow no one to throw refuse overboard.

Do not operate the boat in inclement weather.

---

Always use both throttle levers simultaneously. If one lever is advanced more than the other, or if one engine is shut off during operation, directional control will be affected. Steering compensation may be required. Constant attention and control of the boat is required by the operator for safe operation.

Use of the bilge blower should never replace “smelling” for gasoline fumes. Blower and bilge pump must be off during boat operation.

The ski tow-universal eyelet can be used to attach a ski-rope. Do not use this ring for para-sailing or other uses which may overstress the transom.

Lifting the boat requires special equipment and experience. Do not attempt to lift the boat without such experience or equipment.

Respect the safety and comfort of your passenger(s) and persons being towed on skis.

Always carry the regulatory required safety items onboard. Check with local regulations or your dealer.

Drive prudently and have fun.

# **BOMBARDIER LIMITED WARRANTY: 1997 SEA-DOO® JET BOAT**

---

## **1.WARRANTY COVERAGE PERIOD**

BOMBARDIER INC. ("Bombardier"), as manufacturer, warrants FROM THE DATE OF DELIVERY TO THE FIRST CONSUMER that each 1997 SEA-DOO jet boat sold, as NEW and UNUSED and PREDELIVERED by an authorized North American

SEA-DOO jet boat dealer, will be free from any defects in material and/or workmanship for a PERIOD of:

a) For private use:

TWELVE (12) CONSECUTIVE MONTHS, with the exception for the deck and hull fiberglass structure; and

SIXTY (60) CONSECUTIVE MONTHS for the deck and hull fiberglass structure.

b) For commercial use:

FOUR (4) CONSECUTIVE MONTHS, with the exception for the deck and hull fiberglass structure; and

TWELVE (12) CONSECUTIVE MONTHS for the deck and hull fiberglass structure.

All genuine Bombardier accessories, installed by an authorized SEA-DOO jet boat dealer at the time of delivery of the new and unused SEA-DOO jet boat, carry the same Warranty Coverage Period as for the SEA-DOO jet boat.

## **2.WHAT BOMBARDIER WILL DO**

BOMBARDIER will repair or replace, at its option, all genuine BOMBARDIER part found defective in material and/or workmanship, under normal use, maintenance and service, with a genuine BOMBARDIER part without charge for parts and labor, at any authorized SEA-DOO jet boat dealer during the Warranty Coverage Period.

## **3.CONDITION TO HAVE WARRANTY WORK VALIDATED**

The customer must notify an authorized SEA-DOO jet boat dealer within two (2) days of the appearance of the defect in material and/or workmanship and present to the servicing authorized SEA-DOO jet boat dealer the SEA-DOO Warranty Registration Card or a proof of purchase of the NEW and UNUSED 1997 SEA-DOO jet boat and must sign the repair/work order prior to the start of the repair in order to validate a warranty repair. All parts replaced under this limited warranty become the property of BOMBARDIER.

## **4.EXCLUSIONS - ARE NOT WARRANTED**

Normal wear and tear items;

Labor, parts and lubricant costs of all maintenance services;

Damage caused by failure to provide proper maintenance and/or storage, as described in the (1997 SEA-DOO jet boats Operator's Guide);

Damage resulting from improper repairs, modifications or use of non-approved parts or, repairs done by a non-authorized SEA-DOO jet boat dealer;

Damage resulting from abuse, misuse, neglect, racing;

Damage resulting from accident, fire, theft, vandalism or any act of God;

Incidental or consequential damages, or damages of any kind as but not limited to towing charges, telephone calls or taxi;

Water damages caused by water ingestion;

Damage related to gel coat finish including but not limited to cosmetic gel coat finish, blisters or fiberglass delamination caused by blisters, crazing, spider or hairline cracks; and

---

Damages resulting from improper service or maintenance.

## **5.LIMITATIONS OF LIABILITY**

This warranty gives you specific rights, and you may also have other legal rights which may vary from state to state, or province to province. **WHERE APPLICABLE, THIS WARRANTY IS EXPRESSLY GIVEN AND ACCEPTED IN LIEU OF ANY AND ALL OTHER WARRANTIES, EXPRESSED OR IMPLIED, INCLUDING WITHOUT LIMITATION ANY WARRANTY OF MERCHANTABILITY OR FITNESS FOR ANY PARTICULAR PURPOSE.**

Neither the distributor, any authorized SEA-DOO jet boat dealer nor any other person has been authorized to make any affirmation, representation or warranty other than those contained in this warranty, and if made, such affirmation, representation or warranty shall not be enforceable against BOMBARDIER or any other person.

In no event shall BOMBARDIER be liable for special, consequential or incidental damages, including but not limited to loss of use and transportation costs. Some states or provinces do not allow the exclusion or limitation of incidental or consequential damages, or limitations on how long an implied warranty lasts, so the above limitation or exclusion may not apply.

BOMBARDIER reserves the right to modify this warranty at any time, being understood that such modification will not alter the warranty conditions applicable to the SEA-DOO jet boat sold while this warranty is in effect.

## **6.CONSUMER ASSISTANCE**

- a) In the event of a controversy or a dispute arising in connection with this BOMBARDIER LIMITED WARRANTY, BOMBARDIER suggests that you try to resolve the issue at the dealership level. We recommend discussing the issue with the authorized dealer's service manager or owner.
- b) If further assistance is required, the DISTRIBUTOR's service department should be contacted in order to resolve the matter.
- c) If the issue has still not been resolved, please submit in writing your complaint to:

In Canada:

BOMBARDIER INC.  
SEA-DOO/SKI-DOO Division  
Customer Assistance Center  
Valcourt, Quebec  
CANADA J0E 2L0  
Phone: 514-532-5000

In USA:

BOMBARDIER MOTOR  
CORPORATION OF AMERICA  
SEA-DOO/SKI-DOO Division  
Customer Assistance Center  
P.O. Box 8035  
7575 Bombardier Court  
Wausau, WI 54402-8035  
Phone: 715-848-4957

BOMBARDIER INC.  
SEA-DOO/SKI-DOO Division  
May 1996

® Registered trademark of Bombardier Inc. and/or affiliates.

# LIST OF DISTRIBUTORS

---

## CANADA and Continental U.S.A.

<b>U.S.A.:</b> (Continental U.S.A. Except Puerto Rico)	<b>BOMBARDIER MOTOR CORPORATION OF AMERICA</b> 7575 BOMBARDIER COURT P.O. BOX 8035 WAUSAU, WI 54402-8035 Phone: (715) 842-8886
<b>CANADA</b> Alberta British Columbia Manitoba North West Territories Ontario Quebec Saskatchewan Yukon New-Brunswick Nova Scotia Prince Edward Island	<b>BOMBARDIER INC.</b> SEA-DOO SERVICE DEPARTMENT VALCOURT, QUEBEC J0E 2L0 Phone: (514) 532-2211
Newfoundland	<b>CHARLES R. BELL</b> P.O. BOX 1050 RIVERSIDE DRIVE CORNER BROOKE, NFLD A2H 6J3 Phone: (709) 634-3533 FAX: (709) 634-2444

If your SEA-DOO requires warranty service, you must take it to any authorized SEA-DOO dealer. Be sure to bring your warranty registration card or other valid proof of the original date of purchase. If a question or problem arises regarding warranty, first contact the service manager or owner of the SEA-DOO dealership.

To find the nearest authorized Sea-Doo dealer, dial: 1-800-882-2900.

**NOTE:** If outside Canada and U.S.A., consult the local distributor.

# REGISTRATION NUMBER LOCATION

---

All boats are required by federal law to be registered and legally numbered. Due to space availability for proper display of registration number, refer to the following illustration for location. The registration number must appear on each side of the jet boat.

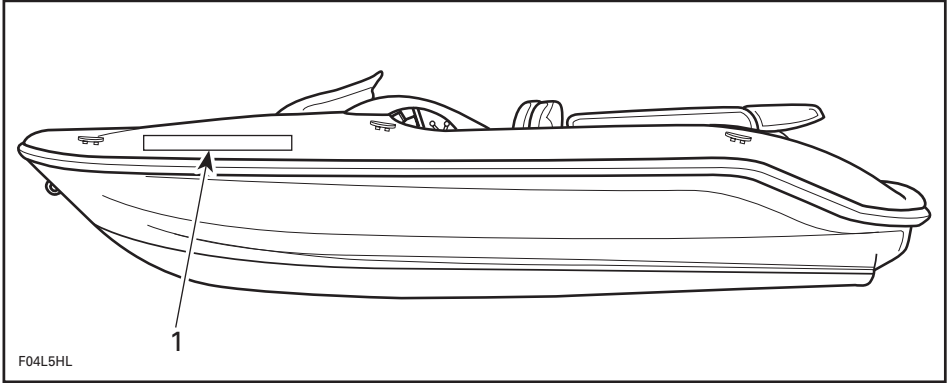

**TYPICAL**

1. Registration number location

# LOCATION OF THE IMPORTANT LABELS

---

Please read the following labels carefully before operating this boat.

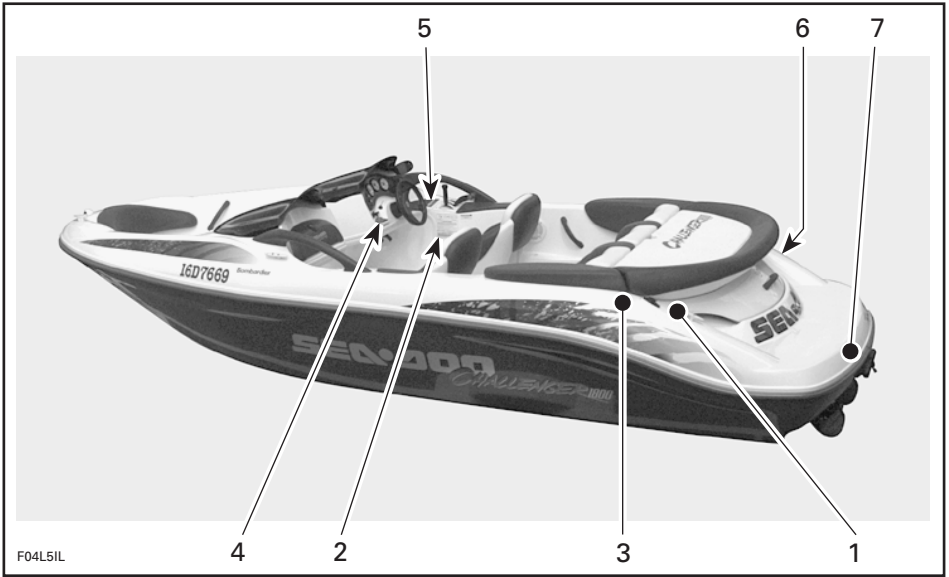



1

**◆ WARNING**

**DO NOT BOOST BATTERY.  
SERVICING OF ELECTRICAL COMPONENTS  
SHOULD BE DONE BY DEALER ONLY.**

F04L2CZ

5

**◆ WARNING**

- Use electronic tether key only.
- Shifter must be in neutral to start engine.
- To operate shifter, throttle lever must be at idle position.

F04L2RY

2

**REMEMBER THESE RULES OF THE ROAD**

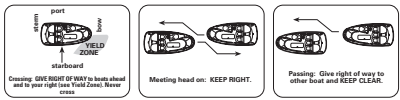

**◆ WARNING**

Read and follow warning labels and operator guide/safety handbook before operation. Severe injury or death can result from ignoring warnings or through improper use of this jet boat. The performance of this jet boat may significantly exceed that of other jet boats you may have operated. Therefore, use of this jet boat by novice or inexperienced operators is not recommended.

- Check throttle/shifter controls and steering position before starting engines.
- Directional control is or wakes with this jet boat.
- Operator and passengers should always wear approved life vests and recommended clothing.
- Do not operate if passengers are not properly seated and using handgrips, or if visibility is obstructed. Do not allow passengers to sit on seat above idle speed.
- Properly attach safety lanyard to your life vest.
- Keep a safe distance from all other water users. Be aware of all boating regulations. Minimum recommended age for use is 16.

**MADE IN CANADA BOMBARDIER INC. XXXX**

**U.S. COAST GUARD  
MAXIMUM CAPACITIES  
7 PERSONS OR 1100 LBS.**

**1100 LBS. PERSONS, GEAR**

**THIS BOAT COMPLIES WITH U.S. COAST GUARD SAFETY STANDARDS IN EFFECT ON DATE OF MANUFACTURE**

F04L5JY

*TYPICAL — READ THE LABEL ON BOAT*

6

**◆WARNING**

**WHILE FUELING, STOP ENGINE. FUEL TANK MAY BE PRESSURIZED, SLOWLY TURN CAP WHEN OPENING. KEEP WATERCRAFT LEVEL. DO NOT OVERFILL. CHECK OIL LEVEL. PERIODICALLY, VERIFY FUEL SYSTEM.**

F01L6VZ

7

**◆ WARNING**

**Engines must be off when using ladder and swim platform.**

F04L6DY

3

**▼ CAUTION**

**OIL ONLY**

**Oil fill capacity 2 US gallons  
Use Bombardier Rotax oil when refilling  
Do not use ashless NMMA oils**

F04L39Y

*TYPICAL*

4

**◆ WARNING**

Gasoline vapors can explode. Before starting engine, operate blower for 4 minutes and check engine compartment bilge for gasoline vapors.

F04L2QY

# IDENTIFICATION NUMBERS

The main components of the jet boat (engines and hull) are identified by different serial numbers. It may sometimes become necessary to locate these numbers for warranty purposes or to trace the jet boat in the event of theft.

## Hull

The Hull Identification Number (H.I.N.) is located on the right side of the transom.

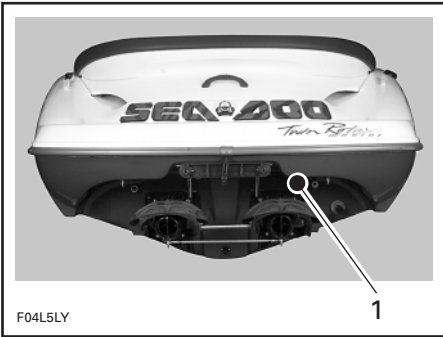

1. Hull Identification Number (H.I.N.)

The jet boat model number can be found on RH side of operator position.

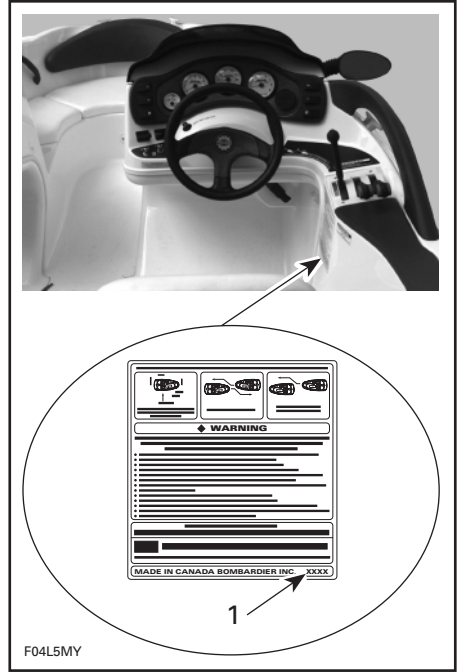

## TYPICAL

1. Model number

## Engines

The Engine Identification Number (E.I.N.) is located on the crankcase on PTO side.

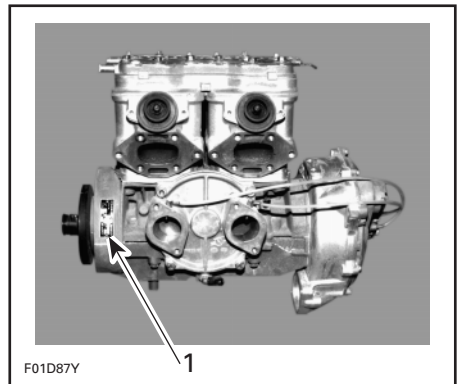

1. Engine identification number

# CONTROLS AND COMPONENTS LOCATION

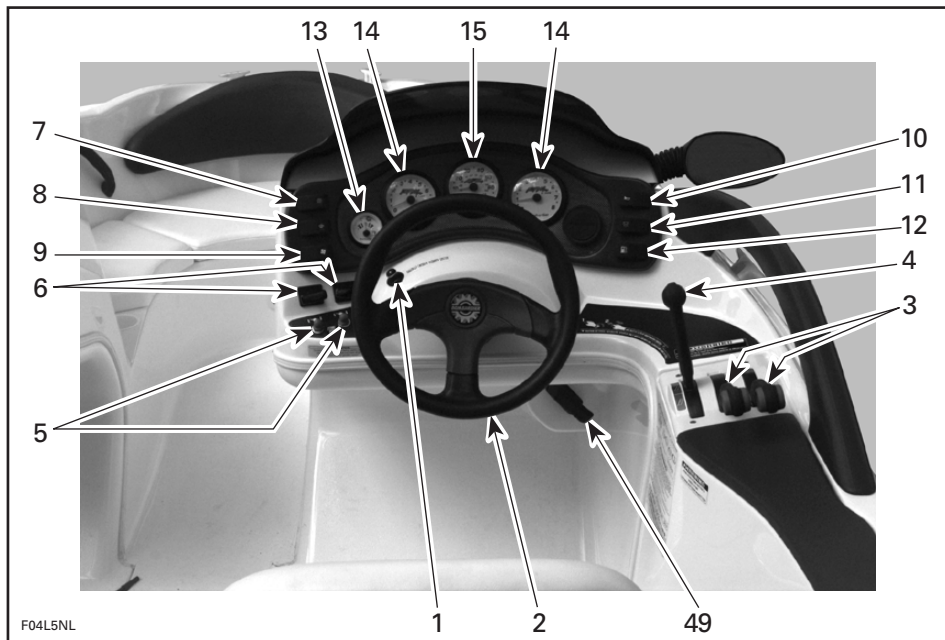

COCKPIT VIEW

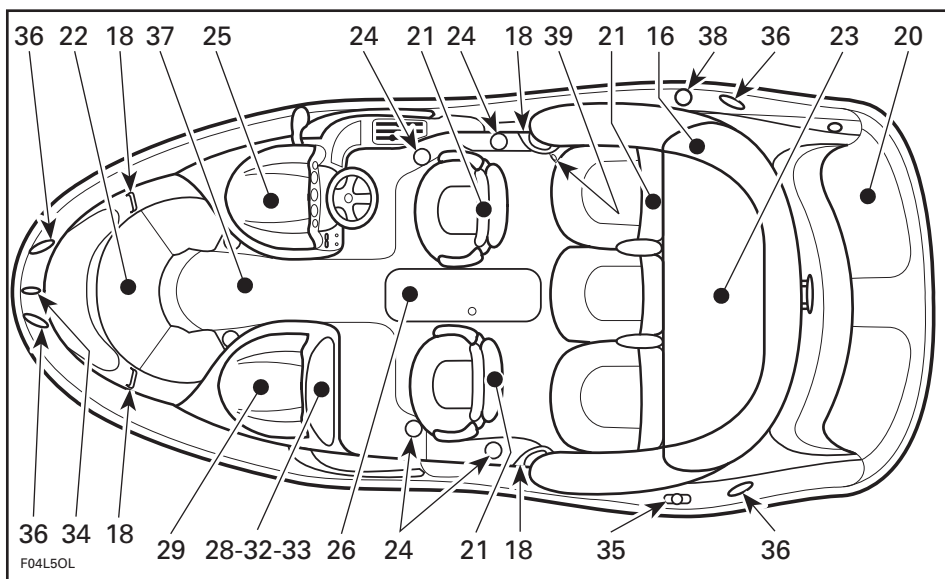

TOP VIEW

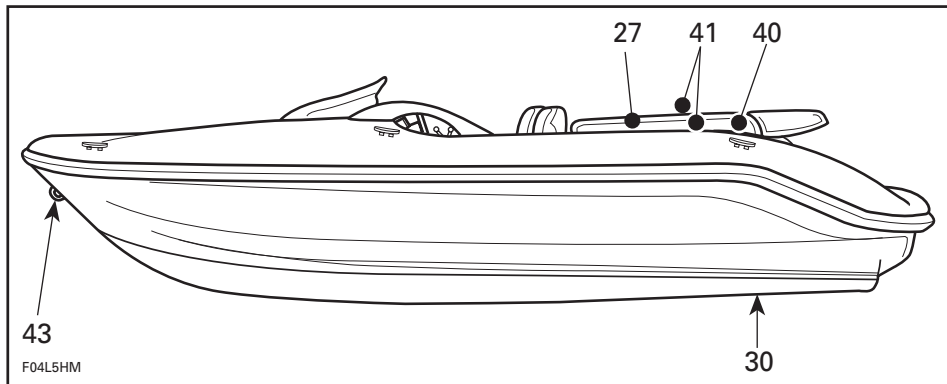

SIDE VIEW

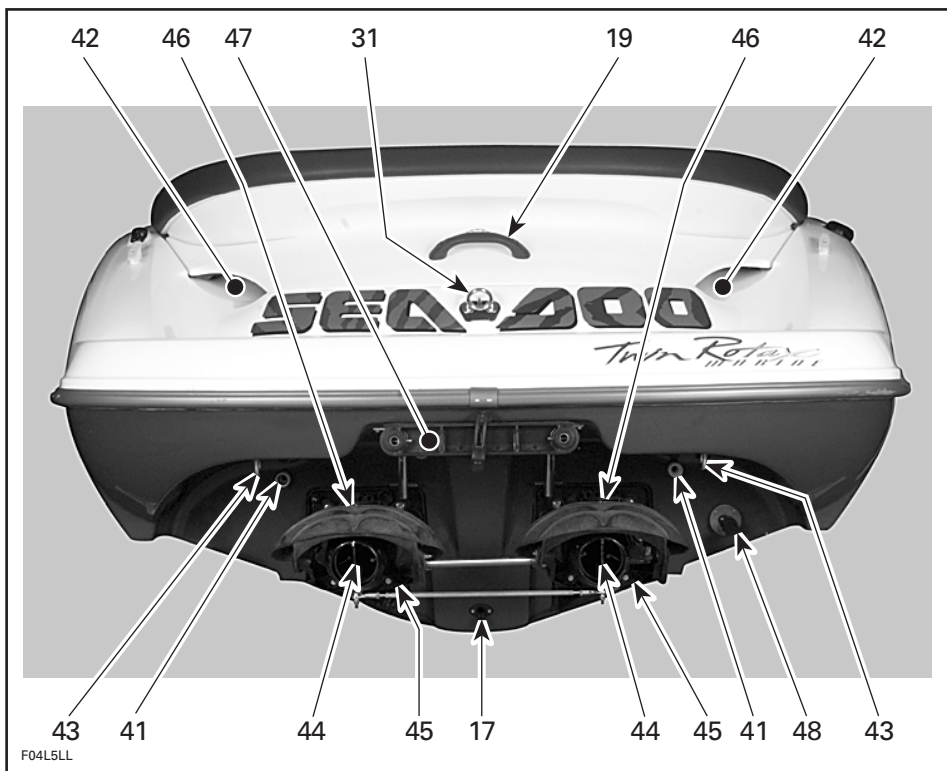

REAR VIEW

- 
1. Safety Lanyard Post
  2. Steering Wheel
  3. Throttle Levers
  4. Shift Lever
  5. Start/Stop Buttons
  6. Choke Levers
  7. Navigation Light Switch
  8. Bilge Pump Switch
  9. Bilge Blower Switch
  10. Horn Switch
  11. Deck Light Switch
  12. Fuel Reserve Switch
  13. Fuel Gauge/Low Oil Level  
Pilot Lamp
  14. Tachometers
  15. Speedometer
  16. Fuel Valves
  17. Bilge Drain Plug
  18. Grab Handles
  19. Rear Grab Handle
  20. Swim Platform
  21. Front and Rear Seats
  22. Sun Seat
  23. Sun Deck
  24. Cup Holders
  25. Right Front Storage  
Compartment
  26. Deck Storage Compartment
  27. Rear Storage Compartment
  28. Glove Box
  29. Left Front Storage Compartment
  30. Jet Pump Water Intakes
  31. Tow Hook
  32. Radio
  33. 12 Volts Accessory Jack
  34. Bow Light
  35. Removable Stern Light
  36. Mooring Cleats
  37. Deck
  38. Fuel Tank Cap
  39. Deck Drain Hole
  40. Oil Injection Tank Cap
  41. Flushing Connectors
  42. Ventilation Ducts
  43. Bow/Stern Eyelets
  44. Jet Pump Nozzles
  45. Sacrificial Zinc Anodes
  46. Reverse Gates
  47. Retractable Ladder
  48. Scupper Valve
  49. Weedless System Lever

## 1) Safety Lanyard Post

The safety lanyard must be installed on the boat's DESS post to allow engine starting. Pull it to stop the engines. Always attach the safety lanyard to the operator's Personal Flotation Device and snap the cap to the DESS post.



### WARNING

Should lanyard cap become loose or fail to remain on its post, replace immediately.

**NOTE:** Do not lubricate the safety lanyard post.

After stopping the engines with the start/stop buttons while the safety lanyard remains on the DESS post, they can be restarted as usual within approximately 10 minutes by pressing again the start/stop buttons. After this delay, it is necessary to remove and reinstall the safety lanyard on the DESS post. Two short beeps should be heard which indicate the system is ready again to allow engine starting.



### WARNING

While the boat engines can be stopped using the start/stop buttons, good driving habits recommend that the safety lanyard also be disconnected when stopping.

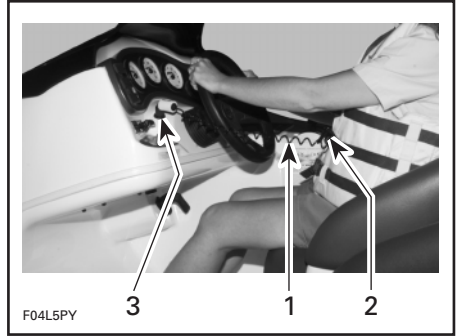

1. Safety lanyard
2. Secure to PFD
3. Snap to DESS post



### WARNING

With jet propulsion systems, no directional control is available when engines are stopped.

## Monitoring System

To assist you when using the boat, a system monitors some components of the boat and sends audible signals through a beeper to inform you of a particular condition. The following chart gives the coded signals related to the safety lanyard only. For other possible codes, refer to the TROUBLESHOOTING section.

NUMBER OF BEEPS	POSSIBLE CAUSE	REMEDY
<b>2 shorts</b> (while installing safety lanyard on DESS post).	<ul style="list-style-type: none"> <li>• Everything is correct with the safety lanyard (good contact and the right lanyard cap).</li> </ul>	<ul style="list-style-type: none"> <li>• Engine can be started normally.</li> </ul>
<b>1 long</b> (while installing safety lanyard on DESS post or when pressing start/stop button in some cases).	<ul style="list-style-type: none"> <li>• Bad connection between safety lanyard cap and DESS post.</li> <li>• Wrong safety lanyard.</li> <li>• Dried salt water or oil in safety lanyard cap.</li> <li>• Improper operation of MPEM or defective wiring harness.</li> </ul>	<ul style="list-style-type: none"> <li>• Remove and reinstall the safety lanyard on the DESS post. Two short beeps should be heard which indicate the system is ready again to allow engine starting.</li> <li>• Use the safety lanyard that has been programmed for the boat. If it does not work, refer to an authorized dealer.</li> <li>• Clean safety lanyard cap.</li> <li>• Refer to an authorized dealer.</li> </ul>

## DIGITALLY ENCODED SECURITY SYSTEM (DESS)

This system allows an anti-start protection against unauthorized use of the boat. The safety lanyard cap specifically contains an electronic circuit that gives it a unique electronic serial number.

When you buy a new boat, only one safety lanyard allows starting the engines on your boat. At this point, this safety lanyard can not be used on another boat and conversely, the one from another boat can not be used on your boat unless otherwise programmed as explained below.

However, the DESS brings a great flexibility. You can buy additional safety lanyard(s) and have it (them) programmed to a boat so that more than one safety lanyard can be usable on a particular boat. To have additional safety lanyard(s) programmed to your convenience, refer to an authorized dealer.

## 2) Steering Wheel

The steering wheel controls the direction of the jet boat. Turning the steering wheel clockwise steers the jet boat to the right and turning it counter-clockwise steers to the left.



### WARNING

**Check steering and movement of steering nozzles operation before starting.**

## Docking Assistance

Whenever the throttle levers are in idle position and the steering is approaching the end of its rotation, the engine speed will be slightly accelerated to increase the jet pump thrust and thus improving the steering control for docking.

### 3) Throttle Levers

They control the speed of the engines and therefore, the speed of the jet boat. When pushed forward, the jet boat accelerates. When fully pulled back, engines return to idle speed and the jet boat is gradually stopped by water drag.



## WARNING

Check throttle levers operation before starting the engines.

**NOTE:** Do not activate throttle levers unnecessarily, carburetors are equipped with fuel accelerator pumps. These pumps deliver fuel to the engines each time throttle levers are moved forward.

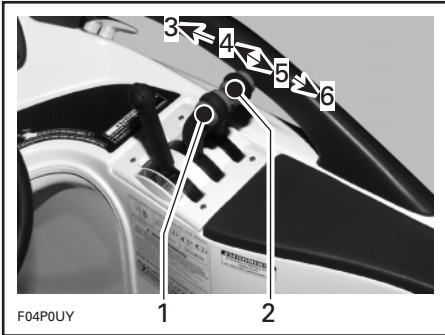

#### THROTTLE LEVERS

1. Port engine
2. Starboard engine
3. Full throttle
4. Increase speed
5. Decrease speed
6. Idle speed

The port throttle lever controls the RPM of the port engine and the starboard lever controls the starboard engine. Although each engine RPM can be controlled individually, we recommend to move both levers simultaneously.

### 4) Shift Lever

A 3-position lever:

- Forward
- Neutral
- Reverse

In order to shift, throttle levers must be fully pulled back to idle speed. Shifter must be in neutral position to allow engine starting.

**NOTE:** Four short beeps will signal that it is not in neutral (with the safety lanyard on the DESS post while pressing one of the start/stop button). Thereafter, 1 short beep will confirm the neutral position (while shifting).

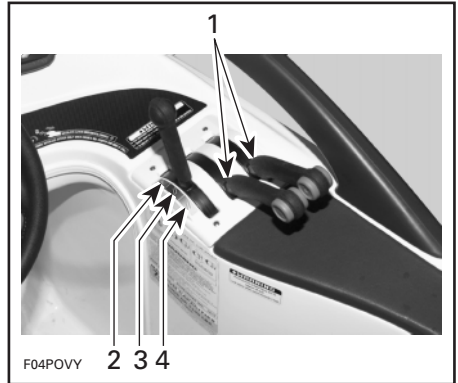

#### SHIFT LEVER

1. Throttle levers must be fully pulled back (idle speed) to shift
2. Forward
3. Neutral
4. Reverse



## CAUTION

Do not force lever, ensure throttle levers are in idle position.



## ◆ WARNING

Only use reverse at slow speed and for the shortest time possible. Always ensure the path behind is clear of obstacles, swimmers and children playing in shallow water. If stopping the engines is required, pull safety lanyard from the DESS post.

## 5) Start/Stop Buttons

Dual function push switches. Used to start as well as to stop engines.

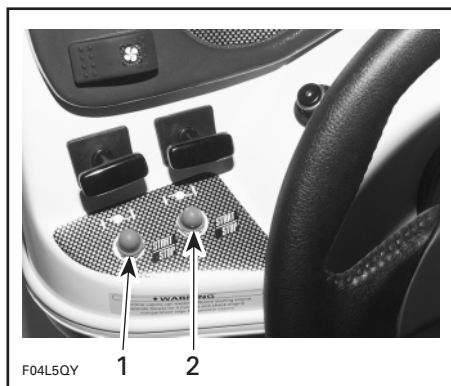

1. For port engine
2. For starboard engine

### Starting

**NOTE:** Shifter must be in neutral position and the safety lanyard must be on the DESS post to allow engine starting.

To start engine, press and hold the button. Release immediately after engine is started. Proceed the same way for the other engine.

**NOTE:** Only one engine at a time can be started.

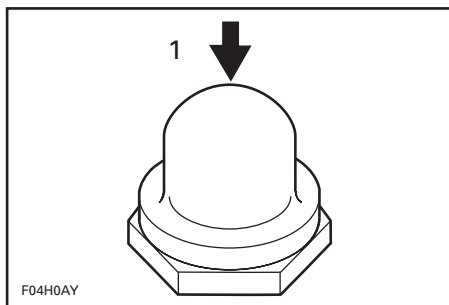

1. Start when engine is NOT running

### Stopping

## ◆ WARNING

While engines can be stopped by pressing the stop button, we strongly recommend the engines be stopped by removing the safety lanyard. This will instill good habits.

Pressing buttons when engines are running will stop the engines.

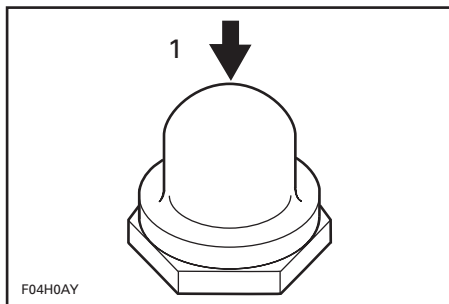

1. STOP when engine IS running

**NOTE:** For complete step by step engine starting procedure, see **Starting the Engines** in operating instructions section.

## ◆ WARNING

Directional control is not available when engines are stopped.

## 6) Choke Levers

The chokes are provided to supply a richer fuel/air mixture when starting cold engines. When the levers are completely pulled, the chokes are fully applied. The use of the chokes are not required with warm engines.

Choke levers must be pulled and held to operate. They will automatically return to their normal position when released.

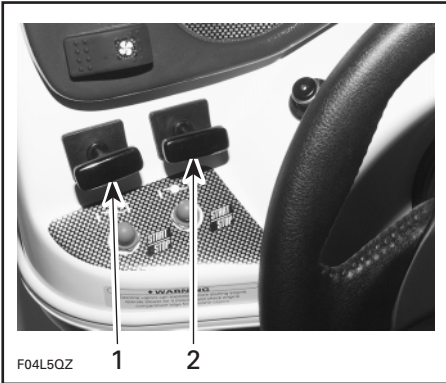

1. For port engine
2. For starboard engine

## 7) Navigation Light Switch

A 3-position push type switch.

Press switch to first position to turn on the stern light (anchorage position).

Press switch to second position to turn on the bow and stern lights.

Press to OFF position to turn off navigation lights.

Navigation lights should always be used between sunset and sunrise. Ensure the stern light is installed. See further in this section for location and installation.

**NOTE:** Switches and gauges are lit when navigation lights are turn on.

## 8) Bilge Pump Switch

A 2-position push type switch.

Press switch to ON position when a manual operation is required (after cleaning, storage, etc.).

Press to OFF position when finished.

### ▼ CAUTION

Do not operate for prolonged time if the bilge is dry.

Using the bilge pump for a prolonged time when the engines are not running will discharge the battery.

### ▼ CAUTION

Ensure to always turn OFF pump after starting engines and before operating the engines above idle.

## AUTOMATIC BILGE PUMP

An automatic bilge pump will evacuate water from the bilge. A water sensor detects the water which activates the pump. After the water is pumped out, the pump shuts-off automatically.

## 9) Bilge Blower Switch

A 2-position push type switch. When ON, it ventilates the engine compartment.

Press switch to ON position to turn on the blower.

The blower must be started 5 minutes prior to starting the engines.

### ◆ WARNING

Always use blower for a minimum of 5 minutes prior to all engine starting then, turn it OFF before operating the jet boat.

Press the switch to OFF to turn off the bilge blower.

Using the bilge blower for a prolonged time when the engines are not running will discharge the battery.

### 10) Horn Switch

A 2-position push type switch.

Press and hold the switch to activate horn.

Release the switch to stop horn.

### 11) Deck Light Switch

A 2-position push type switch.

Press switch to ON position to turn on the deck lights.

Press switch to OFF position to turn off the deck lights.

Using the deck lights for a prolonged time when the engines are not running will discharge the battery.

### 12) Fuel Reserve Switch

A 2-position push type switch.

When the fuel tank level is low, a beeper will sound and the pilot lamp on the switch will flash to advise the operator.

Press the switch to stop the beeper and turn off the pilot lamp.

The reserve contains approximately 10% of the fuel tank capacity.

## ◆ WARNING

Always refill the fuel tank at the first opportunity.

## 13) Fuel Gauge/Low Oil Level Pilot Lamp

### Fuel Gauge

Located in dashboard, the analog gauge continuously indicates the amount of fuel in fuel tank when engines are running.

The gauge is illuminated whenever the navigation lights are used.

**NOTE:** The fuel level can also be verified without having engines running. With the safety lanyard disconnected, push a start/stop button; the gauge will be activated for approximately 30 seconds.

### Low Oil Level Pilot Lamp

The pilot lamp turns on when the injection oil level is low in the oil reservoir. Fill reservoir as soon as possible.

## ▼ CAUTION

Do not run engines out of oil.

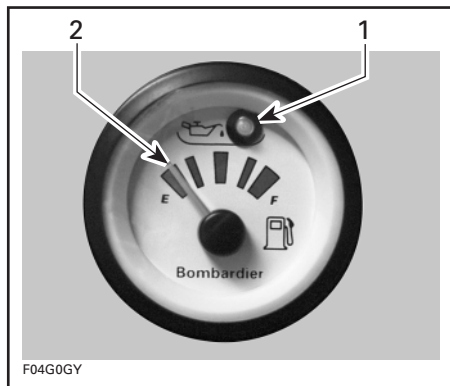

1. Low oil level pilot lamp
2. Fuel level

## 14) Tachometers

Analog tachometers indicate the revolutions per minute (RPM) of the engines. Multiply reading by 1000 to obtain actual RPM.

The gauge is illuminated whenever the navigation lights are used.

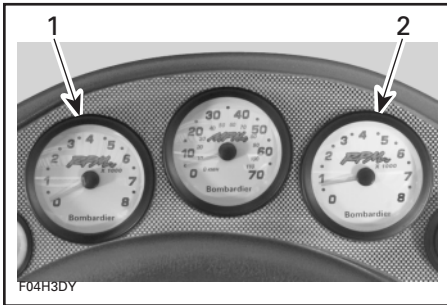

1. Port engine tachometer
2. Starboard engine tachometer

## 15) Speedometer

The analog speedometer indicates the speed of the jet boat in miles per hour (MPH) and kilometers per hour (km/h).

The gauge is illuminated whenever the navigation lights are used.

A speed sensor mounted on the left ride shoe sends the signal to the speedometer.

## 16) Fuel Valves

A 2-position rotary valve: OFF and ON positions.

Open the rear storage compartment cover to access fuel valves.

The fuel valves are located on the right side of the storage compartment.

Rotate the knob to align it with ON or OFF positions.

OFF: Stops fuel supply to carburetors.

**▼ CAUTION**

Turn fuel valves to OFF position when jet boat is not operated and for transportation on the trailer.

ON: Allows fuel to flow to carburetors.

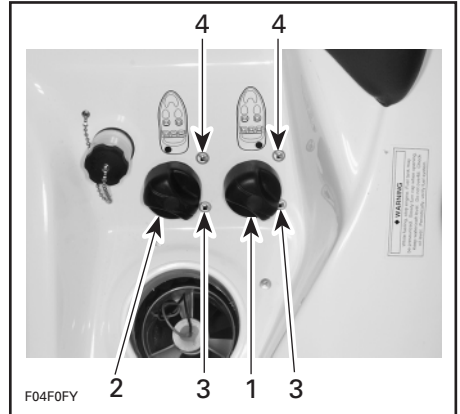

1. For starboard engine
2. For port engine
3. ON
4. OFF

**▼ CAUTION**

Improper opening of fuel valves may restrict flow of fuel. Make sure valves are fully opened while running.

## 17) Bilge Drain Plug

Should water be found in the bilge, it can be easily drained by unscrewing the plug.

**▼ CAUTION**

Remove jet boat from water prior unscrewing the drain plug.

Tilt the jet boat slightly to the rear so that the water can completely flow out of the bilge.

It is suggested to drain bilge on a ramp.

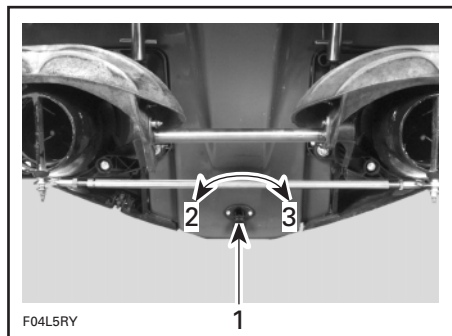

1. Drain plug
2. Loosen
3. Tighten

## ◆ WARNING

Always make sure bilge drain plug is properly tightened.

## 18) Grab Handles

Provides a handhold for the passengers.

## ▼ CAUTION

Never use the grab handles to pull anything or to lift the jet boat.

## 19) Rear Grab Handle

Provides a handhold for boarding when needed.

## ▼ CAUTION

Never use the grab handle to tow anything or to lift the jet boat.

## 20) Swim Platform

Provides a large anti-skid surface for easy boarding from rear of jet boat.

## ◆ WARNING

Swim platform should not be used when engine(s) are running.

## 21) Front and Rear Seats

Each passenger should be seated while underway.

For your convenience, front seats are provided with grab handles.

Front seats are swivels and adjustable fore and aft.

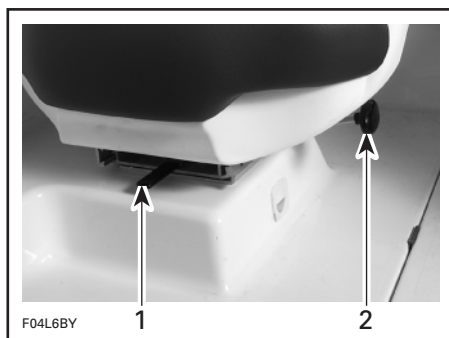

1. Swivel lever
2. Fore and aft knob

For the fore and aft adjustment, turn knob counterclockwise to unlock seat. Move seat at the desired position. Tighten knob clockwise after adjustment is completed.

To unlock swivel, pull lever upward and move it on either side; turn seat at the desired position.

**NOTE:** It is necessary to move the seat completely forward to allow a rotation of 180°.

To lock swivel, move back lever in de-  
tent position and turn seat until it is  
blocked.

**◆ WARNING**

Always ensure swivel is lock  
before riding. Seat must also face  
steering wheel.

## 22) Sun Seat

Located at front of boat, it is provided  
as a sun seat.

**◆ WARNING**

No passenger should use this  
seat except at low speed in calm  
water or when the jet boat is  
stopped.

## 23) Sun Deck

A convenient space to rest or take  
some sun while anchored.

**◆ WARNING**

No passenger should use this  
space except in calm water when  
the jet boat is anchored.

## 24) Cup Holders

Convenient locations for non-alcoholic  
beverages.

**◆ WARNING**

Do not drink alcoholic beverages  
while aboard. Do not keep bot-  
tles, cans etc. in cup holders  
while riding at speed and/or on  
rough water.

## 25) Right Front Storage Compartment

A convenient watertight, lockable  
storage compartment with a remov-  
able basket to carry personal articles.  
The basket is the ideal location for  
spare spark plugs, first aid kit, etc.

**◆ WARNING**

Never leave any heavy or loose  
breakable objects in the storage  
basket. Objects stored below  
basket must not interfere with  
steering or electrical systems.

To access the compartment, open the  
cover using the provided key to unlock  
the release button.

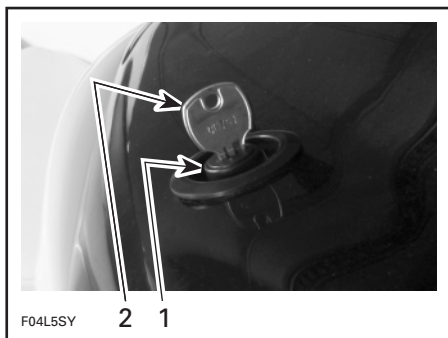

1. Release button
2. Key

Press the release button to open cov-  
er.

When completely open, it remains in  
this position.

The basket is provided with a holder to  
store an approved fire extinguisher  
and tool kit.

The fire extinguisher (sold separately)  
should not be loose in the storage  
compartment. The tool kit contains  
the tools needed to perform basic jet  
boat maintenance.

A second holder contains the *Operator's Guide* and can be used to carry personal articles.

The *Operator's Guide* should be kept in a waterproof bag and remains with the jet boat at all times.

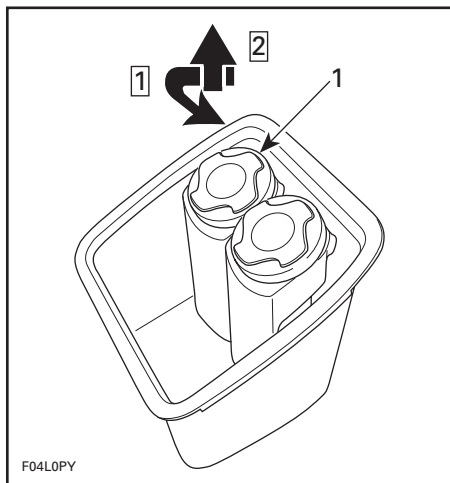

Step **1** : Turn covers counterclockwise to unlock

Step **2** : Lift

1. Extinguisher holder

Reinstall basket as shown.

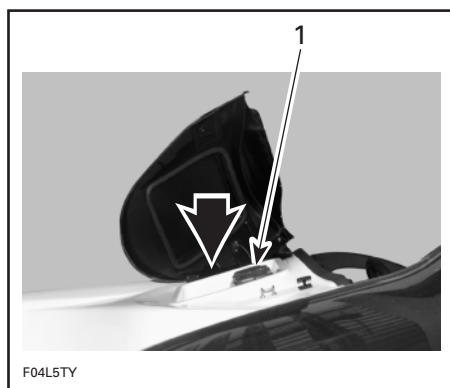

#### BASKET INSTALLATION

1. Holders toward rear

Close the storage compartment cover by pressing the support rod.

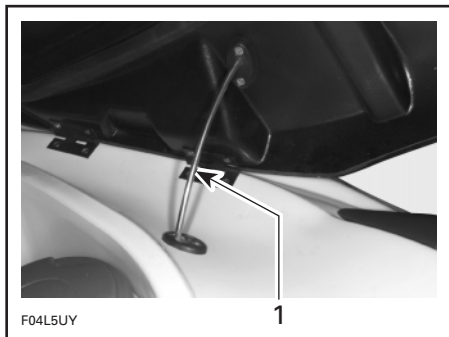

1. Press support rod

**NOTE:** Always relatch and lock storage compartment cover using the key.

## 26) Deck Storage Compartment

The lockable deck storage compartment is a convenient location for water-skis, paddles, anchor and rope, etc.

Use the provided key to unlock latch.

Lift the latch ring and open cover gently until stopped by retaining device.

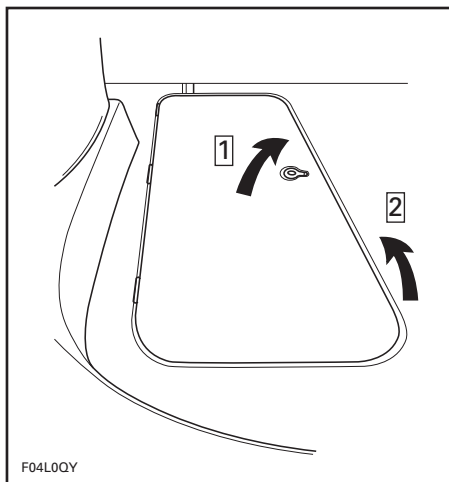

#### TYPICAL

Step **1** : Pull latch

Step **2** : Lift cover

When completely opened, the cover remains in that position.

To close, gently push on the side of the retaining device to release it and lower the cover.

Always relatch cover.

## 27) Rear Storage Compartment

Convenient rear storage location to be used to carry large personal articles.

To open rear cover, open the right front storage compartment cover and pull lever.



F04L5VY

### ◆ WARNING

Never leave any object, rag, tool, etc., in the engine compartment or in the bilge.

When reinstalling storage tray, ensure to properly locate it just below holders, gently lower tray then firmly push it downward to lock.

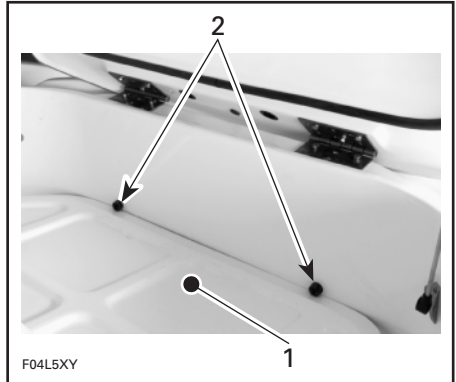

1. Rear storage compartment tray
2. Tray under holders

Gently close storage compartment cover and ensure to relatch.

### ▼ CAUTION

If the rear storage compartment cover is not correctly latched, damage may occur.

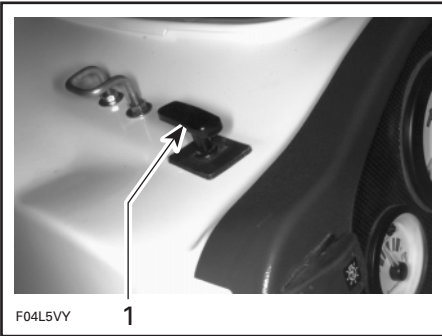

F04L5VY

1. Lever

The gas assist cylinders will complete the opening and hold cover open.

**NOTE:** Access to the rear storage compartment is protected only when the right front storage compartment cover is locked.

The storage tray is removable to give access to the engine compartment. Grab the handle and lift in a rearward movement until opposite holders release.

### ◆ WARNING

When storage tray is lifted or removed, never touch any electrical part when starting engines or while in operation.



## 28) Glove Box

A small, convenient lockable storage compartment for keys, wallet, etc.

To access the glove box, unlock the release button using the provided key and press button.

**NOTE:** Always relatch and lock glove box.

## 29) Left Front Storage Compartment

A convenient watertight, lockable storage compartment with a removable cooler.

The cooler is the ideal location to keep a lunch or beverages.

The storage area below the cooler can be used to carry large personal articles. Ideal location for sleeping bags, blanket, duffle bags, etc.

### ◆ **WARNING**

**Never leave any loose breakable objects in this storage area.**

To access the storage compartment, open the cover. See the **Right Front Storage Compartment** for the complete procedure as mentioned earlier in this section.

Remove the cooler.

**NOTE:** Always relatch and lock storage compartment cover using the key.

## 30) Jet Pump Water Intakes

The water is drawn up by the impellers through these openings. The impellers and the drive shafts are protected by a grate. Refer to OPERATING INSTRUCTIONS section for an overview of the propulsion system.

## 31) Tow Hook

The hook is provided for your convenience.

The universal eyelet allows a rope with a hook, a closed end or an open end to be attached.

## 32) Radio

Open the glove box to access the radio.

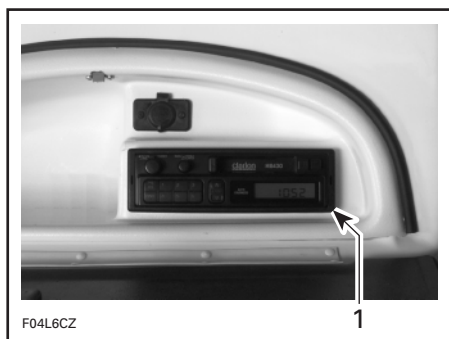

1. Radio

Refer to its guide for a complete explanation of the features and controls.

Using the radio for a prolonged time without engines running may discharge the battery.

**NOTE:** The radio is better protected from theft when the glove box and left front storage compartment cover are locked.

## 33) 12 Volts Accessory Jack

A 12 volts jack to plug temporary accessories.

Open the glove box to access the accessory jack.

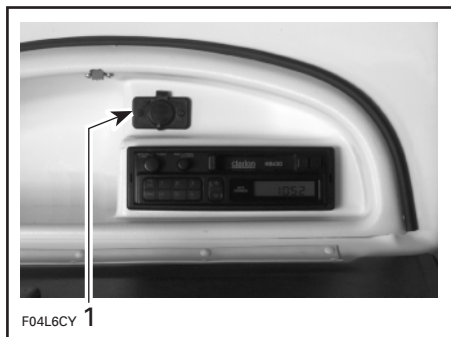

1. Accessory jack

Using the accessory jack for a prolonged time without engines running may discharge the battery.

### 34) Bow Light

Mandatory red/green light. See **Light Switch** as mentioned earlier in this section.

### 35) Removable Stern Light

Mandatory stern white light.

It is recommended to keep it in rear storage compartment at all times except when needed.

To remove from storage cover, pull it out. Snap in place to store again.

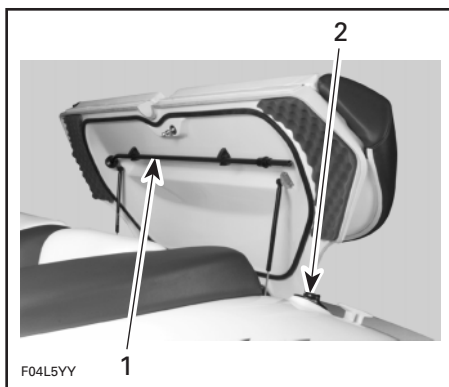

1. Stern light storage location  
2. Stern light operation position

### Installation

- Lift connector cap.
- Insert post in connector hole. Ensure to align hole keyway with post screw head.
- Firmly push downward to engage terminals.
- Push lock ring downward. Turn until locked. It may be necessary to slightly turn it to allow its insertion in the hole.
- Check light operation. See **Light Switch** as mentioned earlier in this section.

### ◆ WARNING

The jet boat is not equipped with headlights or spotlights.

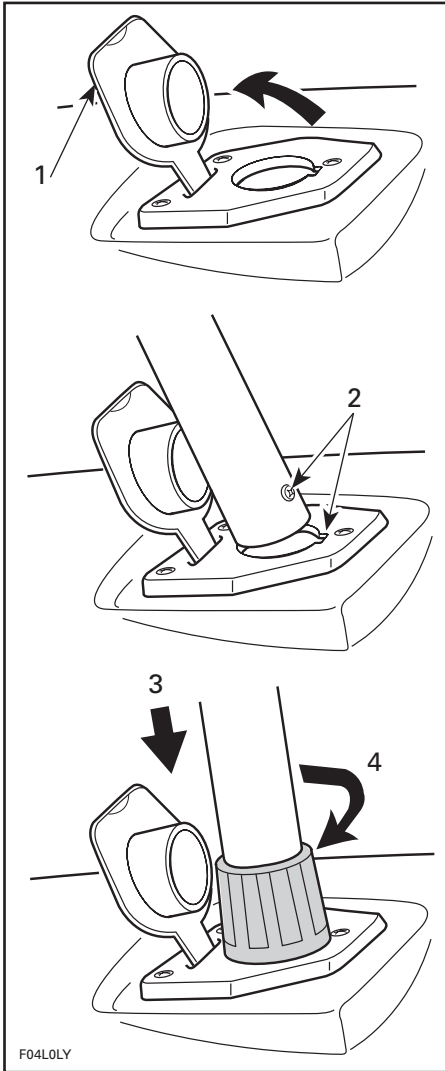

1. Lift
2. Align screw in groove
3. Push downward
4. Turn to lock

**▼ CAUTION**

Ensure dielectric grease is present in connector area of light to prevent corrosion.

### 36) Mooring Cleats

When mooring to a dock, it is recommended to secure with both front and rear cleats. The use of dock lines with sealed air fenders is recommended to protect your boat.

**▼ CAUTION**

Never use mooring cleats to pull anything or to lift the jet boat.

### 37) Deck

Flat surface of boat, should be kept clean and clear.

### 38) Fuel Tank Cap

Unscrew the cap counterclockwise to allow fuel tank filling. Fully tighten when finished.

**◆ WARNING**

Never use a lit match or open flame to check fuel level. Refer to FUEL AND LUBRICATION for fuel specification.

### 39) Deck Drain Hole

It provides drainage of water from rain, deck washing, water splashing, etc.

Keep clean to avoid clogging.

### 40) Oil Injection Tank Cap

The cap is located under the rear storage compartment cover on port side.

Unscrew cap by turning counterclockwise and when finished, firmly tighten by turning clockwise. Close cover. Refer to FUEL AND LUBRICATION for injection oil specification.

## 41) Flushing Connectors

Refer to POST-OPERATION CARE section for proper use.

**NOTE:** Port connector is for port engine and starboard connector is for starboard engine.

For your convenience, there are additional flushing connectors under the rear storage compartment cover. Lift cover, the flushing connectors are on each side of the storage compartment.

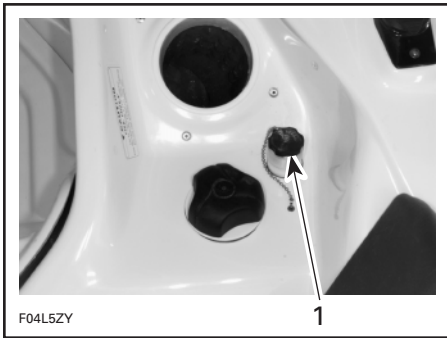

1. Flushing connector with its cap (port side)

## 42) Ventilation Ducts

This is where air flows to supply engine and ventilate engine compartment.

### ▼ CAUTION

Never obstruct the ducts.

## 43) Bow/Stern Eyelets

Eyelets can be used for mooring, towing and as a tie-down point during transportation.

## 44) Jet Pump Nozzles

They are turned from side to side via operator input from the steering wheel. This provides jet boat directional control when engines are running.

## 45) Sacrificial Zinc Anodes

Located on ride shoes, they protect the jet drive against galvanic corrosion by sacrificing its metal to be slowly eroded instead of the jet drive metals. Refer to MAINTENANCE section.

## 46) Reverse Gates

Moves from upward to downward position to get Forward, Neutral, Reverse and inversely. These positions are obtained by moving shift lever.

### ▼ CAUTION

Do not attempt to reverse while at speed.

## 47) Retractable Ladder

A convenient ladder to help reboarding the jet boat.

### ◆ WARNING

Engines must be OFF when using the ladder.

Pull latch to unlock the ladder.

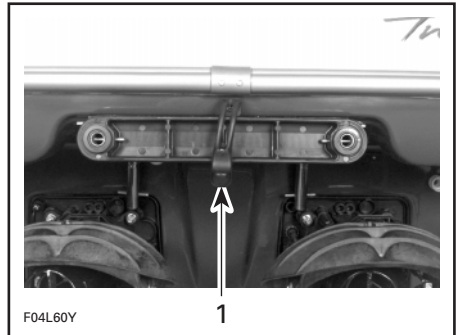

1. Latch

Pull ladder toward rear until it is fully extended, then push down.

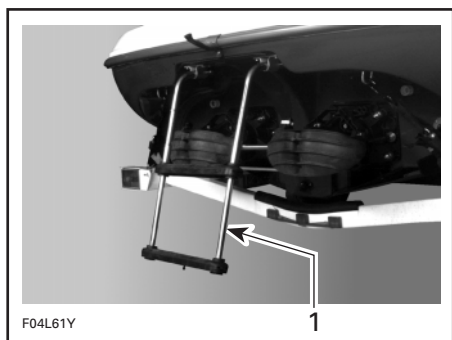

1. Ladder fully extended

To store ladder, lift then push forward.

**▼ CAUTION**

Always lock the ladder using the latch.

## **48) Scupper Valve**

The water drained from the deck exit the jet boat from this valve.

## **49) Weedless System Lever**

Stop engines prior to using the lever. Pull the lever while turning counter-clockwise to lower the water intake grates. This should clean the water intake grates from any weeds. Completely push lever when finished. Refer to SPECIAL PROCEDURE section for details.

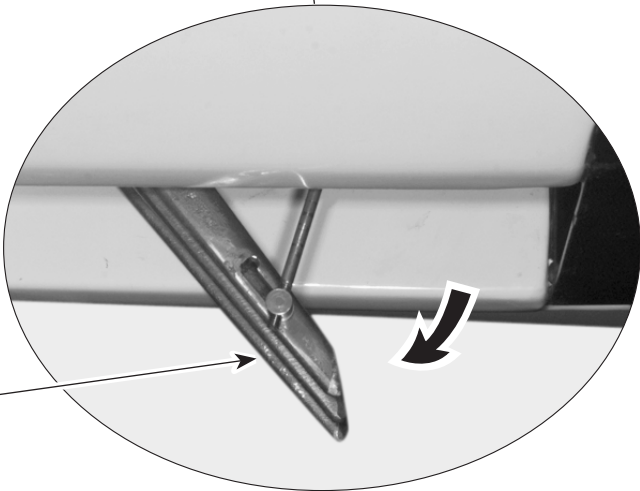
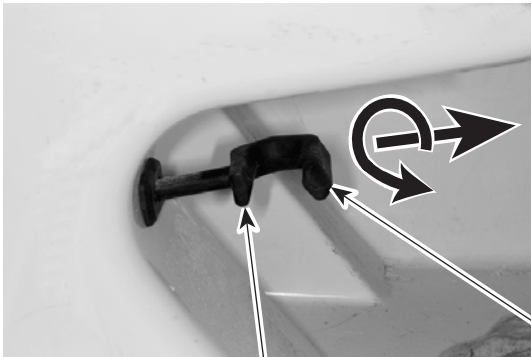

F04J1JL

1. Pull lever while turning counterclockwise
2. Water intake grate lowered

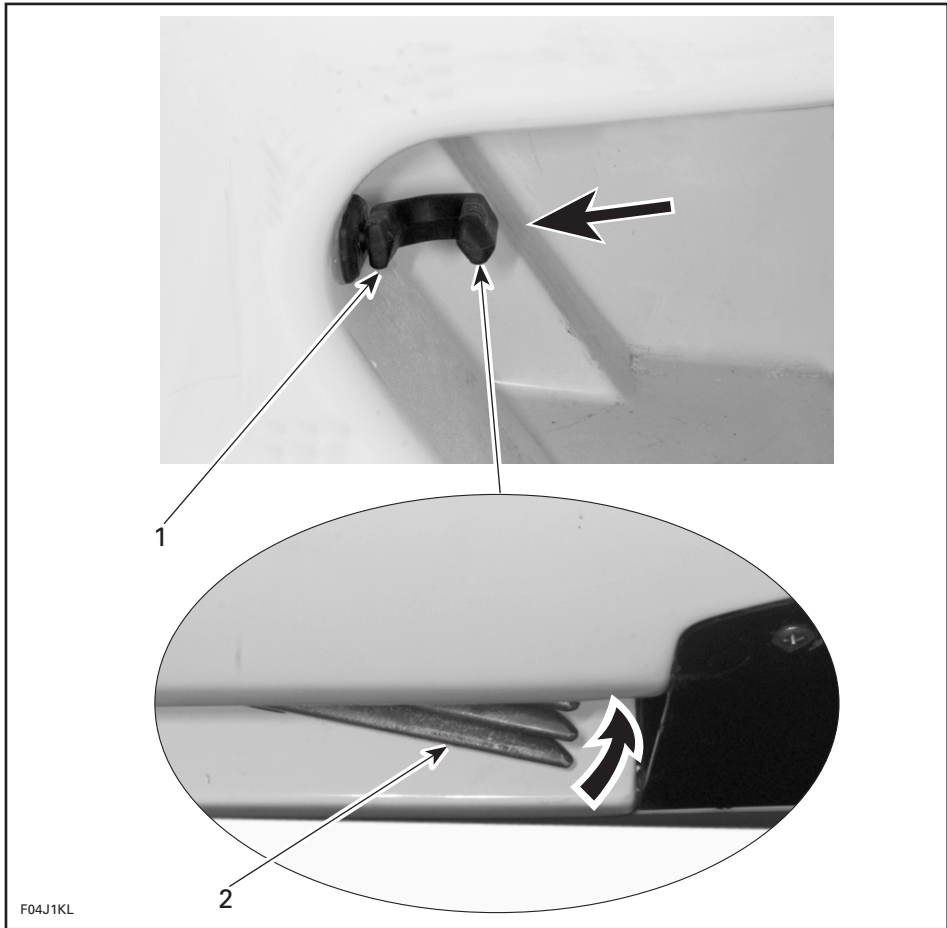

1. *Push lever for normal riding*
2. *Water intake grate in riding position*

# FUEL AND LUBRICATION

---

## Fueling Procedure



### WARNING

Follow these safe boating fueling instructions explicitly.

Make sure the jet boat is tied securely to the fueling pier.

Use bilge blower for a minimum of 5 minutes.

Turn off engines, bilge blower, bilge pump and any other devices that could produce a spark.

Close rear storage cover to prevent fumes from entering the engine compartment.

Disembark all people.

Do not smoke or allow open flames in the vicinity.

Have a fire extinguisher close at hand.

Do not insert the spout too far in filler neck.

Pour fuel slowly so that air can escape from the reservoir and prevent fuel flowback.

Fill fuel tank to bottom of filler neck. Do not overfill.

Fully tighten fuel tank cap and wipe off any fuel spillage.

Before starting, ensure there are no fuel fumes in the engine compartment, ventilate using the blower as necessary.

## Recommended Fuel

Use regular unleaded gasoline with 87 octane (Ron + Mon/2) specification.

**NOTE:** Look on service station pump sticker for octane specification. Do not mix oil with fuel except at engine break-in. Refer to BREAK-IN PERIOD section. Always check oil injection reservoir level when refueling.

The use of good quality fuel is necessary. A well known fuel brand is highly recommended.



### CAUTION

The use of a poor quality fuel can result in jet boat performance deterioration and damage to fuel system and engine components. Never experiment with other fuels or fuel ratios. Never use fuel containing alcohol, methanol or similar products including naphtha.

## Recommended Oil

Use only BOMBARDIER-ROTAX injection oil.

The oil is available from authorized dealers. It is a blend of specially selected base oils and additives which provides outstanding lubrication, engine cleanliness and minimum spark plug fouling.

**NOTE:** High quality low ash API TC injection oil for 2-cycle engines can be used if BOMBARDIER ROTAX INJECTION OIL is not available.



### CAUTION

Never use 4-cycle petroleum or synthetic motor oil and never mix these with outboard motor oil. Do not use NMMA TC-W, TC-W2 or TC-W3 outboard motor oils or other ashless type 2-cycle oil. Avoid mixing different brands of API TC oil as resulting chemical reaction may cause severe engine damage.



---

## Oil Injection System

A sufficient amount of injection oil should be maintained in the reservoir. To check, open rear storage cover then lift and hold the tray. Look oil level through the translucent reservoir.

The use of a funnel is recommended to pour the oil into the reservoir. Stop filling as soon as oil appears at approximately 13 mm (1/2 in) from top of reservoir. Do not overfill. Wipe off any oil spillage.

**NOTE:** Always carry a spare 1 liter of BOMBARDIER ROTAX INJECTION OIL.

 <b>CAUTION</b>
--

<p>Always maintain a sufficient amount of injection oil in the oil reservoir. Check and refill every time you refuel. Do not overfill. If the engines run out of oil, severe engine damage will occur. If the oil reservoir is allowed to almost empty, air can enter into the system and it must be bled. Immediately refer to an authorized dealer to have the oil injection system inspected.</p>
--

# BREAK-IN PERIOD

---

## Engines

With Bombardier-Rotax® jet boat engines, a break-in period is required before operating the engine at full throttle. Engine manufacturer recommendation is about 10 operating hours.

During this period, maximum throttle should not exceed 3/4, however, brief full acceleration and speed variations contribute to a good break-in. Continued wide open throttle accelerations, prolonged cruising speeds and overloading the engines are detrimental during the break-in period.

To assure additional protection during the initial break-in period, it is recommended to add 3 liters (3 qt) of BOMBARDIER ROTAX INJECTION OIL in the fuel tank. The oil should be added for the first full fuel tank filling only.

To add injection oil in the fuel tank, proceed as follows:

Fill fuel tank with approximately 50 liters (12 gal) of gasoline; then, add the required quantity of injection oil in the fuel tank.

Fill up fuel tank with gasoline. **Do not overfill.**

**NOTE:** It is important to proceed in this order to allow a proper mixing of the oil in the gasoline. If oil is added first in an empty fuel tank, fuel lines will be filled up with injection oil leading in a no start condition of the engines.



## CAUTION

Remove and clean spark plugs after engine break-in.

## 10-Hour Inspection

It is highly recommended that after the first 10 hours of operation, the jet boat be checked by an authorized dealer. This inspection will also provide the opportunity to discuss any unanswered questions you may have encountered during the first hours of operation.

---

**The 10-hour inspection is at the expense of the jet boat owner.**

---

<b>10-HOUR INSPECTION CHECK LIST</b>	<b>✓</b>
Engine ignition timing if required	
Spark plug inspection, cleaning and adjustment	
Fuel system lines and fasteners/pressurization test	
Carburetor adjustment including throttle/choke cables if required	
Oil lines and filter	
Oil injection pump adjustment if required	
Engine support and engine rubber mounts	
Muffler, battery and reservoir fastening devices	
Exhaust system hose clamps torque	
Carburetor flange screws and flame arrester support	
Steering system and docking system	
Steering cable adjustment if required	
Shifter cable adjustment if required	
Ensure that throttle levers keep the selected position	
Adjust lever(s) friction as necessary	
Hose condition and fasteners	
Bilge pump and bilge blower	
DESS system and start/stop buttons operation	
Monitoring beeper	
Electrical connections (starter, battery, etc.)	
Lighting system inspection	
Impeller shaft reservoir oil replacement	
Torque jet pump retaining nuts	
Impeller condition, impeller/wear ring clearance	
PTO flywheel lubrication	
Water intake grates/weedless system/hull condition	
Inspection of fasteners for tightness	
Inspect/clean engine drain tube	

NOTE: Inspection applies for both engine systems where applicable.

**We recommend that this inspection chart be signed by an authorized dealer.**

\_\_\_\_\_  
Date of 10-hour inspection

\_\_\_\_\_  
Authorized dealer signature

\_\_\_\_\_  
Dealer code

# PRE-OPERATION CHECKS

Some of the following items may not have been previously covered in this guide, however they will be described in the MAINTENANCE or SPECIAL PROCEDURES section. Please refer to these portions to have more detailed information.

Prior to operating the Jet boat, verify the following:

## ◆ WARNING

Except otherwise specified, safety lanyard must always be removed from DESS post prior to verify any of the following.

ITEM	OPERATION	✓
Hull	Inspect.	
Jet pump water intakes	Inspect/clean.	
Bilge	Drain. Ensure plug is secured.	
Battery	Inspect tightness of cables and retaining straps.	
Navigation lights	Check operation.	
Fuel/oil reservoirs	Refill.	
Engine compartment	Verify fuel/oil system components.	
Fire extinguisher	Inspect condition/mounting.	
Steering	Check operation.	
Throttle/shifter system	Check operation.	
Weedless system	Ensure it is not activated	
Bilge blower and bilge pump	Check operation.	
Safety lanyard/engine start/stop buttons	Check operation.	
Mandatory safety boating equipment	Check operation.	

## Hull

Inspect hull for cracks or damage.

## Jet Pump Water Intakes

Remove weeds, shells, debris or anything else that could restrict the flow of water and damage the cooling system or propulsion units. Clean as necessary. If any obstruction can not be removed, refer to an authorized dealer for servicing.

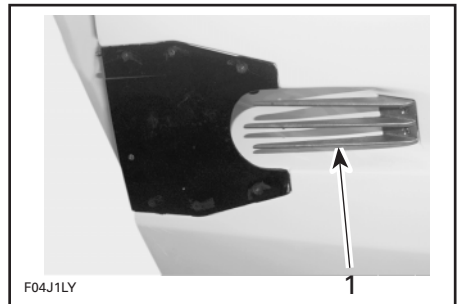

TYPICAL  
1. Inspect this area

---

Inspect leading edges of the impellers, if they have nicks or bends, performance will be greatly reduced.

## Bilge

Should water be present in the bilge, turn on pump switch to completely empty the bilge.

### ▼ CAUTION

Do not run the pump dry for a prolonged period of time.

## Battery

### ◆ WARNING

Verify tightness of battery cables.

## Fuel/Oil Reservoirs

With the jet boat horizontal, fill the fuel tank.

Check the oil level and refill reservoir as necessary.

## Engine Compartment

Check condition of fuel/oil system components.

### ◆ WARNING

Should any leak or gasoline odor be present, do not start the engines. Immediately refer to an authorized dealer.

## Fire Extinguisher

Make sure it is full, in good condition and well secured.

## Steering System

Assisted by another person, check steering operation for free movement. When the steering is centered, the jet pump nozzles should be in the straight ahead position. Ensure the jet pump nozzles pivot easily while steering is turned.

## Throttle System

Check throttle levers once for free and smooth operation.

## Shifter System

Check reverse gate operation for free movement. With shift lever in forward position, the gates must be in upward position. With the shift lever in neutral position, gates must be in middle position. With shift lever in reverse position, gates must be in downward position.

## Weedless System

Ensure lever is fully pushed.

## Safety Lanyard and Engine Start/Stop Buttons

Ensure that switches operate properly. Start engines and stop them using each switch individually.

### ◆ WARNING

If engine does not shut-off when pushing engine start/stop button or by disconnecting the safety lanyard, stop the engine by applying the choke. Do not operate the jet boat further, see an authorized dealer. Only start the jet boat once all items have been checked and operate properly.

# OPERATING INSTRUCTIONS



## WARNING

Always perform PRE-OPERATION CHECKS before operating the jet boat. Become thoroughly familiar with all controls and the function of each. Should any control or instruction be not fully understood, refer to an authorized dealer.

## Principle of Operation

### Propulsion

Each engine is directly coupled to a drive shaft which, in turn, rotates an impeller. This impeller is accurately adjusted in a housing where the water is drawn up from underneath the jet boat. Then, the water flows through the impeller to a venturi. The venturi accelerates the water and produces thrust to move the jet boat. Pushing the throttle levers forward increase engine speed and therefore jet boat speed.

With shift lever pushed forward, the jet boat moves forward. In pulled back position, the jet boat moves backward. The middle position is neutral and the jet boat is at the minimum thrust for most conditions. Neutral and reverse are achieved by means of a gate, which is installed on jet pump venturi housing. This gate directs the water flow to obtain the desired direction.

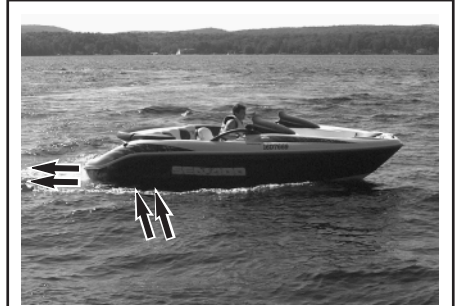

F04L62Y



## WARNING

Whenever an engine is to be started, the operator and passengers should always be sitting in the jet boat with the shifter lever in neutral position and throttle levers in idle position.

### Turning

Turning the steering pivots the jet pump nozzles which control the jet boat direction. Turning the steering clockwise will turn the jet boat to the right and inversely. The throttles must be applied to turn the jet boat.



## WARNING

With jet propulsion systems, directional control is lost when the throttles are pulled back. Throttles must be engaged and steering turned to change the direction of the jet boat. Steering efficiency will differ depending on the number of passengers, load and water conditions.

The more the throttles are applied while turning the steering, the more responsive the boat will be.

The jet boat may behave differently when carrying passengers. The passengers should grip the grab handles. Reduce speed and avoid sharp turns. Avoid excessive speeds and choppy water conditions especially when carrying passengers.

## Boarding from a Dock or in Shallow Water

As with any boat, getting aboard should be done carefully and engines must not be running.

When boarding from a dock, slowly place one foot on the jet boat deck nearest to the dock and then move the other foot inside the boat. Push the jet boat away from the dock.



F04L63Y

### ▼ CAUTION

Although the boat requires only 30 cm (1 ft) of water to float, the engine should be started with at least 90 cm (3 ft) of water below the hull to protect the propulsion system.

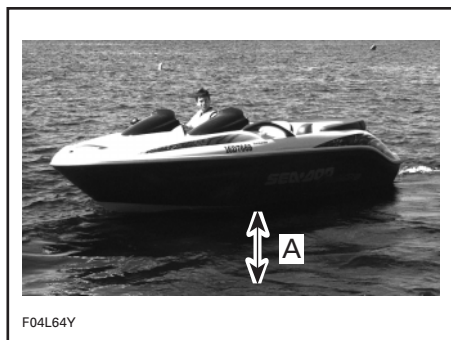

F04L64Y

A. 90 cm (3 ft)

In shallow water, board the jet boat either from the side or the swim platform.

## Starting the Engines

Shift lever must be in neutral position to allow engine starting.

Always activate bilge blower 5 minutes minimum before starting the engine. The bilge blower will ventilate the bilge.

### ◆ WARNING

Bilge blower must be turned off during jet boat operation.

Turn the fuel valves to ON position.

Before unloading the jet boat from the trailer, engines can be started for about 10 seconds to verify proper operation. Remove stern (rear) straps before starting the engines.

### ◆ WARNING

Do not touch electrical parts or jet pump area when engines are running.

Attach the safety lanyard to the operator's PFD and snap the cap to the DESS post.

**NOTE:** If you hear some beeper signals other than 2 short beeps, it indicates a particular condition that must be corrected. Refer to the TROUBLE-SHOOTING section for the meaning of the coded signal.

Operator and passengers should be sitting in the jet boat seats prior to starting the engines.

Grip steering wheel with your right hand and place both feet on the floorboard. Turn off bilge blower.

Start one engine at a time. Check tachometer to monitor engine.

### Cold Engine

Fully pull back throttle levers to idle position.

### First Engine

Fully pull one choke lever and depress the starting button just below it.

**NOTE:** Either engine can be started first.

**NOTE:** Do not push the throttle lever forward while starting a cold engine.

## ▼ CAUTION

To avoid starter motor overheating, the cranking period should not exceed 5-10 seconds and a rest period should be observed between cranking cycles to let the starter cool down and its mechanism disengage.

A few seconds after, completely release the choke lever and if necessary, slightly push throttle forward to keep engine running.

**NOTE:** In an emergency, the jet boat may be operated with one engine. Refer to SPECIAL PROCEDURE section.

### Second Engine

Start the second engine following the same procedure but use the other choke lever, start/stop button and throttle lever. Always monitor engines with tachometers.

### Leaving the Shore

**Slowly** accelerate to reach deeper water. Do not apply full throttle until the engines are warm.

**NOTE:** Throttles must be in idle position in order to be able to shift in forward.

## ◆ WARNING

In shallow water, shells, sand, pebbles or other objects could be drawn up by the jet pumps and be thrown rearward.

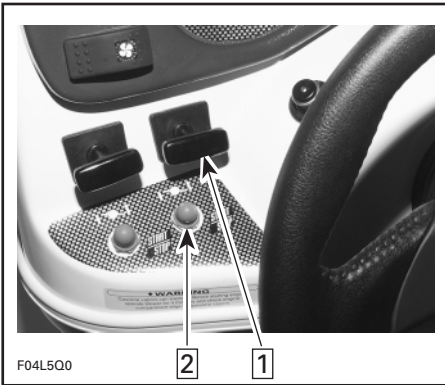

### TYPICAL

Step **1** : Fully pull and hold choke lever

Step **2** : Press the start/stop button

Immediately after engine is started, release starting button and release choke lever half way.



## Warm Engines

The same procedure as a cold engine applies, except the choke does not need to be applied and throttle lever has to be slightly pushed forward to approximately 1/4.

## Obstacles

Verify that the path ahead of the jet boat is clear of other craft or obstacles. Avoid riding close to swimmers. Check local boating laws for safe operational areas.

### ◆ WARNING

Collision with objects, other boaters, etc., is the most common cause of accidents resulting in injury. Always keep a safe distance from other water users.



F04L65Y

## Boarding in Deep Water

Swim to the rear of the jet boat.

Pull the ladder.

Use both steps to reach the grab handle and pull yourself upward to place one of your feet on the swim platform.



F04L66Y



F04L67Y



F04L68Y

### ▼ CAUTION

Never use propulsion components as a supporting point to board the jet boat.



## WARNING

Do not start engines until all passengers are properly seated.

### Rough Water or Poor Visibility Operation

Avoid operation in these conditions. If you must do so, proceed with caution and prudence using minimum speed. Turn on navigation lights.

### Crossing Waves

Substantially reduce speed and cross the wave head on to assist steering.



## WARNING

When crossing waves, operator and passengers should brace themselves. Wave or wake jumping can be dangerous and illegal.

### Stopping/Docking

The jet boat is slowed by water drag. The stopping distance will vary depending on weight, speed, water surface condition, presence and direction of wind and current.

The operator should familiarize himself with the stopping distance under different conditions.

Reduce speed, reduce RPM to idle and shift to neutral, reverse or forward as required when approaching a dock then shut off the engines just before coming alongside

### Docking Assistance

Whenever the throttle levers are in idle position and the steering wheel is approaching the end of its rotation, one engine will be slightly accelerated to increase the jet pump thrust and thus improving the steering control for docking.



## WARNING

Become familiar with this feature during your first ride.

### Beaching



## CAUTION

It is not recommended to run the jet boat to the beach.

Proceed the same way as for docking except for the following:

Come slowly to the beach and shut off the engines using the safety lanyard when reaching about 90 cm (3 ft) of water under the hull, then pull the boat to the beach. Ensure that all accessories are OFF.



F04L64Y

A. 90 cm (3 ft) of water under the hull



## **WARNING**

In shallow water, shells, sand, pebbles or other objects could be drawn up by the jet pumps and be thrown rearward.

As necessary, the cooling system of both engines should be flushed before restarting, to remove sand or shell accumulation which may clog the water passages.

### **Shutting Off the Engines**

To keep jet boat directional control, the engines should be running until the jet boat is stopped assuming at least 90 cm (3 ft) of water is present underneath the hull.

To shut off the engines, completely pull back throttle levers then remove safety lanyard or press the engine start/stop buttons.

Always remove safety lanyard from jet boat.



## **WARNING**

Should the engines be shut off, jet boat directional control is not available. Never leave the safety lanyard on an unattended jet boat.

# POST-OPERATION CARE

## General Care

Should any water be present in the bilge, unscrew the drain plug and tilt the jet boat to the rear in order to allow water to flow out.

Wipe up any remaining liquid in the engine compartment (bilge, engines, etc.) with clean dry rags. This is particularly important in salt water use.

Remove the jet boat from the water every day to prevent marine organisms growth.

## Additional Care for Foul Water or Salt Water

When the jet boat is operated in foul water and particularly in salt water, additional care must be taken to protect the jet boat and its components. Rinse trailer and boat's bilge area with fresh water.

### ▼ CAUTION

Failure to perform proper care such as: rinsing, cooling system flushing and anticorrosion treatment, when used in salt water, will result in damage to the jet boat and its components.

## Cooling System Flushing and Engine Internal Lubrication

Flushing the cooling system with fresh water is essential to neutralize corroding effects of salt or other chemical products present in water. It will help to remove sand, salt, shells or other particles in water jackets (engine, exhaust manifold, tuned pipe) and/or hoses.

Engine lubrication and flushing should be performed when the jet boat is not expected to be used further the same day or when the jet boat is stored for any extended time.

Proceed as follows:

### ◆ WARNING

Perform this operation in a well ventilated area.

1. Clean jet pump by spraying water in its inlet and outlet and then spray a soapy solution.
2. Open rear storage compartment and remove storage tray.
3. Connect a garden hose directly to the flushing connector. To prevent water leak, ensure the rubber washer is in the boat's connector.  
**Do not open the water tap yet.**

**NOTE:** A quick connect hose adapter can be fixed to ease garden hose installation to boat's connector.

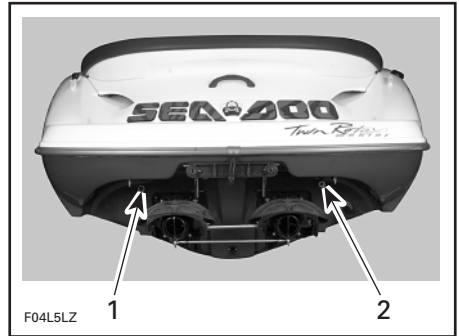

1. Flushing connector for port engine
2. Flushing connector for starboard engine

**NOTE:** Either of the flushing connectors can be used. The ones on the transom, or the ones in the engine compartment area. When using the upper connector, it is necessary to prevent water going out directly by the connector on the transom. Install a hose pincher (not supplied) (P/N 529 030 400) on the hose between the transom and the T-fitting as shown.

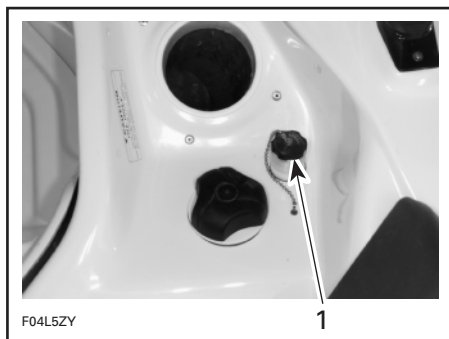

1. Flushing connector with its cap (port side)

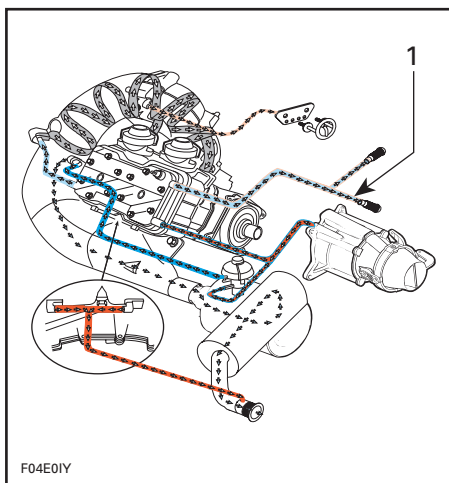

**TYPICAL**

1. Install a hose pincher in this section

4. Start the engine then immediately open the water tap.

**◆ WARNING**

Do not touch any electrical parts or jet pump area when engine is running.

**▼ CAUTION**

Never flush a hot engine. Always start the engine before opening the water tap. Otherwise, water will back flow through the tuned pipe into the engine and may cause damage to internal parts. Open water tap immediately after engine is started to prevent overheating.

5. Run the engine about 3 minutes at a fast idle around 3500 RPM.

**▼ CAUTION**

Never run engine longer than 5 minutes. Drive line seal has no cooling when jet boat is out of water.

6. Remove plug from air intake silencer cover and spray BOMBARDIER LUBE lubricant through hole keeping engine at fast idle during one minute.

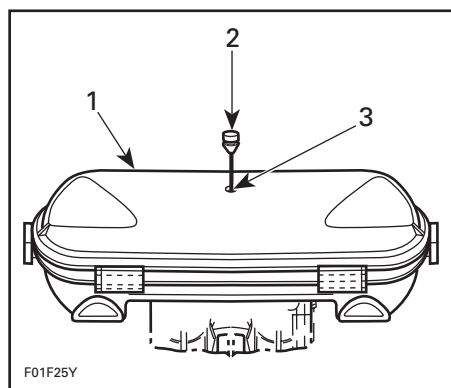

1. Air intake silencer cover
2. Pull plug
3. Spray BOMBARDIER LUBE here

7. Close the water tap then stop the engine.

**▼ CAUTION**

Always close the water tap before stopping the engine.

**NOTE:** For storage, engine should be run out of fuel while lubricating by turning the fuel valve to OFF position.

**▼ CAUTION**

When engine begins to run irregularly because of fuel starvation, immediately stop water flow before engine dies.

8. Disconnect the garden hose. Ensure the rubber washer remains in boat's connector.
9. Remove spark plug cables and connect them on the grounding device.

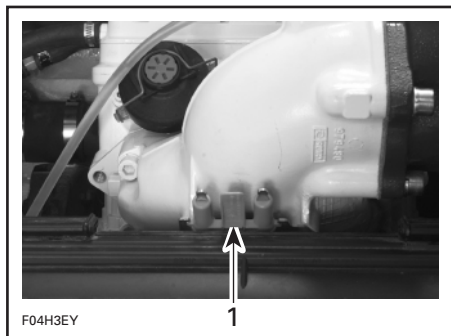

**TYPICAL**

1. Grounding device

10. Remove both spark plugs and spray BOMBARDIER LUBE lubricant into each cylinder.
11. Crank the engine a few turns to distribute the oil on cylinder wall.
12. Apply anti-seize lubricant on spark plug threads then reinstall them.

13. Reinstall plug on air intake silencer cover.

14. Wipe up any residual water from the engine.

**NOTE:** Repeat the same procedure for the other engine.

**Anticorrosion Treatment**

To prevent corrosion, spray a corrosion inhibitor (salt water resistant) such as BOMBARDIER LUBE lubricant or equivalent over metallic components in engine compartment.

**NOTE:** Engine fogging should be done with BOMBARDIER LUBE lubricant whenever the jet boat is to be stored for few days or a long period.

Apply dielectric grease (salt water resistant) on battery posts and cable connectors.

**▼ CAUTION**

Never leave rags or tools in the engine compartment or in the bilge.

# SPECIAL PROCEDURE

---

## Engine Overheating

If the monitoring beeper continuously sounds, **stop engines immediately.**

Perform the **Jet Pump Water Intake and Impeller Cleaning** procedure in this section.

Flush cooling system, refer to POST OPERATION CARE.

If engine(s) still overheat, refer to an authorized dealer for servicing.

## Jet Pump Water Intake and Impeller Cleaning

Weeds, shells or debris can get caught on the intake grates, drive shafts and/or impellers. A clogged water intake may cause troubles such as:

1. **Cavitation:** Engine speed is high but jet boat moves slowly due to reduced jet thrust; jet pump components may be damaged.
2. **Overheating:** Since the jet pump operation controls the flow of water to cool the engine, a clogged intake will cause the engine to overheat and damage engine internal components.

The clogged area can be cleaned as follows:

**In-water cleaning:** Pull safety lanyard to stop engines. Let the boat stop by itself then pull the wheedles system lever. This will lower the water intake grates. Wait a while to allow weeds or other debris to escape from grates. Thereafter, fully push wheedles system lever and start engines. It may be necessary to repeat the procedure.

In severe conditions if the above method does not work, the following can be performed:

- With engines running, put shift lever in reverse position and vary throttles quickly several times.
- Retry boat.

Most of the time, debris will escape from the propulsion systems.

**Out of water cleaning:** If the systems are still clogged, shut off the engines by removing the safety lanyard.



## WARNING

**Always remove safety lanyard from switch to prevent accidental engine starting before cleaning the jet pump area.**

Pull the wheedles system lever to lower the water intake grates. From underneath boat, manually clean each water intake area. If the systems are still clogged, refer to an authorized dealer for servicing.

If the jet pumps can not be easily cleared of debris, the jet boat should be returned to the trailer or to a boat lift.



## CAUTION

**Avoid jet boat operation in weed-ed areas. If unavoidable, vary jet boat speed. Weeds tend to entangle more at steady and slow speeds. Inspect water intake grates for damage. Refer to an authorized dealer for repair as necessary.**

## Capsized Boat

The jet boat is designed so that it should not turn over easily due to its long and wide dimensions. If the jet boat ever capsizes, remember that it will continue to float, and it is usually best to remain with it, you will be more easily located by a search plane, helicopter or boat.



## WARNING

Operator and passengers should always wear approved personal flotation devices.

### Submerged Boat

If the jet boat has been submerged and engines are water-flooded, it must be serviced by an authorized dealer immediately.



## CAUTION

See an authorized dealer as soon as possible to service the engines.

### Towing the Boat in Water

In the event the jet boat becomes inoperative, tie a tow rope to the bow (front) eyelet. However, special precautions should be taken.

The maximum recommended towing speed is 24 km/h (15 MPH).

When towing your boat in water, pinch the water supply hose from the jet pump housing to the engine with a hose pincher (not supplied) (P/N 529 030 400) shown in the following illustration.

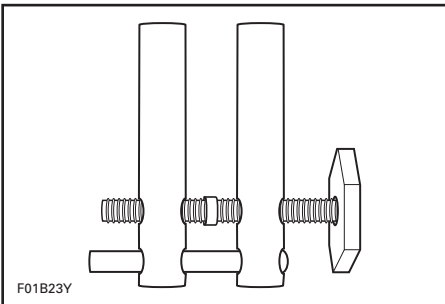

**NOTE:** If for some reason, you operate the jet boat over 24 km/h (15 MPH) with only one engine running, the non-running engine should have its water supply hose plugged.

This will prevent the cooling system from filling which may lead to water being injected into and filling the exhaust system. Without the engine running there isn't any exhaust pressure to carry the water out the exhaust outlet.



## CAUTION

Failure to do this may result in damage to the engine. If you must tow a stranded boat in water and do not have a hose pincher be sure to stay well below the maximum towing speed of 24 km/h (15 MPH).

Snugly install the hose pincher on the hose as shown in the following illustration.

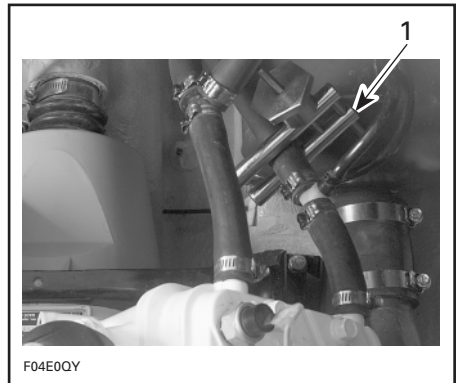

1. Install hose pincher on this hose





## CAUTION

When finished towing the boat you must remove the hose pincher before operating it. Failure to do so will result in damage to the engine.

### **Operating the Boat with Only One Engine**

If in an emergency situation the jet boat is operated with only one engine, special care must be taken. See above in **Towing the Boat in Water** for complete procedure.

### **Low-Charge Battery Condition**

See your dealer to have it charged or replaced.



## WARNING

Do not charge or boost a battery in the boat.

# MAINTENANCE

## ◆ WARNING

Only perform procedures as detailed in this guide. It is recommended that the assistance of an authorized dealer be periodically obtained on other components/systems not covered in this guide. Unless otherwise specified, engines must not be running and the safety lanyard must be removed for all maintenance procedures.

**NOTE:** Where applicable, maintenance procedure applies for both engine systems.

## Lubrication

### PTO Flywheel

Use SEA-DOO synthetic grease and lubricate every 10 hours of use. Proceed as follows:

Open rear storage compartment cover.

Remove storage tray.

Remove the wing nuts, washers and pull out PTO flywheel guard.

## ◆ WARNING

Always remove safety lanyard cap from its receptacle to prevent accidental engine starting before removing the PTO flywheel guard.

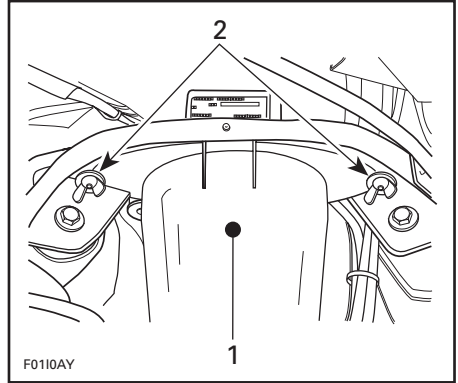

1. Flywheel guard
2. Wing nuts

Using a grease gun, carefully lubricate PTO flywheel at grease fitting until drive shaft boot is just beginning to expand.

## ▼ CAUTION

Immediately stop lubricating as soon as boot begins to expand to prevent boot damage or slipping.

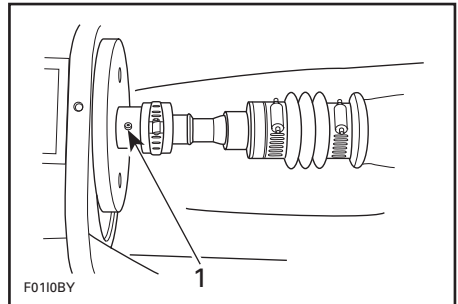

1. Grease PTO flywheel

Secure PTO flywheel guard.

## Anticorrosion Protection

### Throttle/Choke Cables

Lubricate the throttle and choke cables with BOMBARDIER LUBE lubricant every 25 hours of use (every 10 hours in salt water use).

### Electrical Connections

As necessary, apply dielectric grease on battery posts and all exposed cable connectors including stern light connectors on mat and boat.

### Additional Lubrication

BOMBARDIER LUBE lubricant will help to prevent corrosion and keep proper operation of moving mechanisms.

Lubrication of the following items should be performed every 50 hours in fresh water use but every 10 hours in salt water use.

### Choke Levers

Fully pull choke levers and lubricate the metallic portion.



## Rear Storage Compartment Cover Mechanism and Hinges

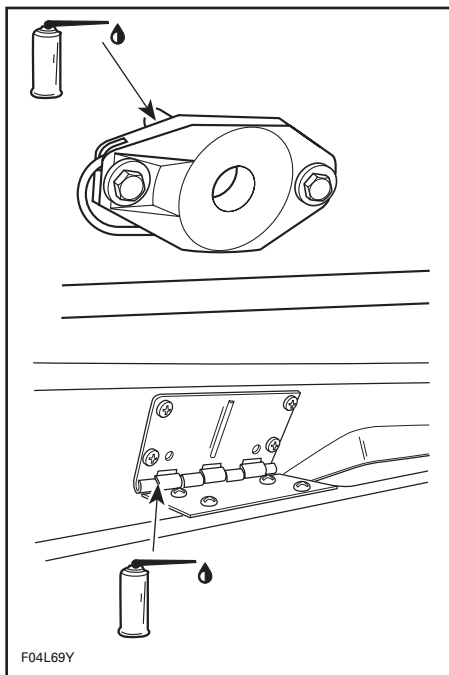

### Locks

Lubricate locks of glove box, front storage compartment covers and deck storage compartment.

### Carburetors and Oil Injection Pump

Lubricate springs, shafts and exposed portion of cables. Grease carburetor linkage with synthetic grease.

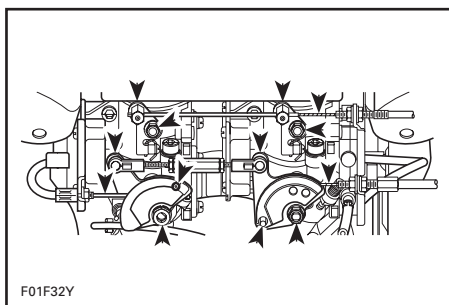

TYPICAL

---

## **Reverse Gates**

Lubricate pivoting points and mechanism of each side.

## **Weedless System**

From underneath of hull, lubricate water intake grates at pivoting points and cable rods.

## **Rear Storage Compartment Cover Cylinders**

Lubricate rod of cylinders.

## **Periodic Inspection**

Routine maintenance is necessary for all mechanized products. A periodic inspection contributes to the products life span.

The following maintenance chart gives guidelines for regular jet boat servicing schedule to be performed by you and/or by an authorized dealer. The schedule should be adjusted according to operating conditions and use.

## Periodic Inspection Chart

DESCRIPTION	FREQUENCY				
	EVERY 10 HOURS	EVERY 25 HOURS	EVERY 50 HOURS	EVERY 100 HOURS OR SEASONALLY	TO BE PERFORMED BY
Lubrication/corrosion protection	①		✓		OPERATOR
DESS operation/DESS post and safety lanyard cap terminal condition				✓	DEALER
Engine ignition timing				✓	DEALER
Spark plug replacement			✓		DEALER
Throttle/choke cables operation/lubrication	①	✓			OPERATOR
Flame arrester inspection			✓		DEALER
Carburetor adjustment including choke/throttle cable adjustments				✓	DEALER
RAVE valve				✓	DEALER
Water flow regulator valve				✓	DEALER
Oil injection pump adjustment				✓	DEALER
Fuel filter and oil filter inspection		✓			DEALER
Oil filter and fuel filter replacement				✓	DEALER
Engine head screws, torque				✓	DEALER
Steering system and docking assistance system			✓		DEALER
Throttle and shifter systems				✓	DEALER
Fastener tightening (flame arrester, carburetors, engine exhaust system, etc.)			✓		DEALER
Muffler, battery and reservoir fastening devices			✓		DEALER
Fuel/oil line, check-valve and hose inspection, fuel system pressurization			✓		DEALER
Inspect/clean engine drain tube		✓			DEALER
Bilge pump/deck drain hole inspection			✓		OPERATOR
Electrical box condition			✓		DEALER
Battery condition			✓		DEALER
Starter cables		✓			DEALER
Monitoring beeper/electrical connections			✓		DEALER
Impeller shaft reservoir oil level/oil condition		✓		Replace	DEALER
Impeller condition and impeller/wear ring clearance		②	✓		DEALER
Drive shaft boot and spline condition (both ends)		②	✓		DEALER
PTO flywheel lubrication	✓				OPERATOR
Water intake grates and weedless system condition		②	✓		DEALER
Hull condition and ride shoes				✓	DEALER
Cooling system flushing ③		✓			OPERATOR
Navigation lights condition		✓			DEALER
Sacrificial zinc anodes			✓		OPERATOR
Bilge blower inspection			✓		DEALER

**NOTE:** Inspection applies for both engine systems where applicable. Some items are included in the PRE-OPERATION CHECKS and are not necessarily repeated in this chart.

- ① Every 10 hours in salt water use.
- ② These items have to be initially checked after 25 hours. Thereafter, servicing to be made as specified in this chart.
- ③ Daily flushing in salt water or foul water use.

## Throttle and Choke Cables

### Throttle Cables

Move the throttle levers forward and rearward once. They must operate smoothly. Refer to an authorized dealer if adjustment is necessary.

**NOTE:** Do not activate throttle levers unnecessarily, carburetors are equipped with fuel accelerator pumps. These pumps deliver fuel to the engines each time throttle levers are moved forward.



### WARNING

Do not alter or tamper with throttle cables or routing.

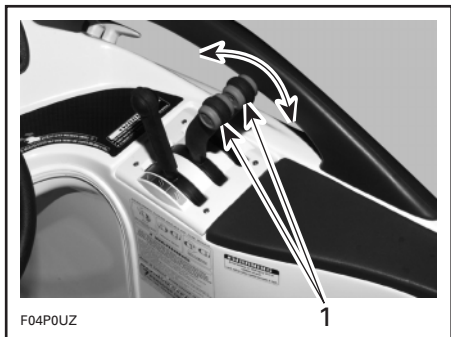

#### THROTTLE LEVERS

1. Must move freely

### Choke Cables

Ensure choke cables operate smoothly and without any hesitation from fully open to fully closed. When the choke lever is fully pulled, choke must be fully applied. Refer to an authorized dealer if necessary.

## Carburetors

Carburetor adjustment is very important to allow good engine operation and therefore jet boat performance. Carburetor adjustment requires technical knowledge and experience to have the correct mixture supplied to the engine. These critical adjustments must be performed by an authorized dealer once a year or more often if necessary.



### CAUTION

Serious engine damage can occur with improper carburetor adjustment.

## Fuel and Oil Filters

These filters must be replaced by an authorized dealer annually. Fuel system pressurization should be conducted at the same time.



### CAUTION

An obstructed oil filter will cause oil starvation resulting in serious engine damage.

## Steering/Jet Pump Nozzle Adjustment

When the steering is aimed in straight ahead position, the jet pump nozzles should be in the same direction to allow the jet boat to run in a straight line.

Refer to an authorized dealer if an adjustment is necessary.



### WARNING

Ensure the steering/jet pump nozzles operate freely from side to side and are not stressing the steering cables. Steering system should be inspected every 50 hours by an authorized dealer.

## Reverse Gates

When shift lever is in forward position, reverse gates should be in an upward position and locked there. With the shift lever in neutral position, reverse gates should be in intermediate position. When shift lever is in reverse position, reverse gates should be in downward position. Refer to an authorized dealer if an adjustment is necessary.

### ◆ WARNING

Ensure the shifter/reverse gates operates freely and are not stressing the reverse cable.

## Fuses

All fuses for the accessories are mounted on a fuse block, which is located below the removable basket in the right front storage compartment.

A decal in the storage basket shows the rating, position and identification of the fuses.

There are spare fuses in rubber holders attached to the fuse holders.

The fuse block is also protected by a separate 20A fuse located inside the electrical box, in the engine compartment.

**NOTE:** If all accessories are not working, check this fuse.

Fuses for the electrical system of the engines and gauges are mounted on the Multi-Purpose Electronic Module (MPEM), which is located in the electrical box in the engine compartment.

A decal on the electrical box cover shows the rating, position and identification of the fuses.

There are spare fuses in rubber holders attached to the fuse holders.

To check the condition of a fuse, open its holder.

Remove fuse.

If defective, replace the fuse by one of the same rating. Make sure to properly close the fuse holder.

### ▼ CAUTION

Do not use a higher rated fuse as this can cause severe damage. If a fuse is regularly burnt, refer to an authorized dealer.

### ◆ WARNING

If any water is found in the electrical box, immediately refer to an authorized dealer before operating the boat.

When reinstalling electrical box cover make sure its seal is well positioned.

## Bilge Blower

Verify bilge blower for proper operation. It is located in starboard ventilation duct.

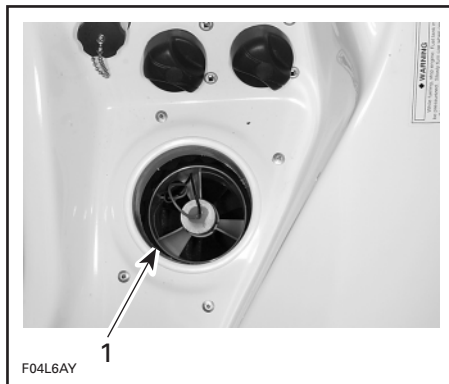

1. Blower



## WARNING

If bilge blower does not operate properly, immediately refer to an authorized dealer before operating the jet boat.

### Sacrificial Zinc Anodes

Replace as necessary.

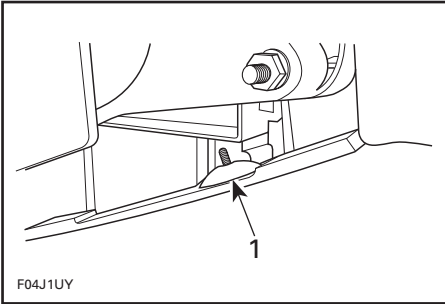

1. Zinc Anode

### Navigation Light Bulb Replacement

Bow Light

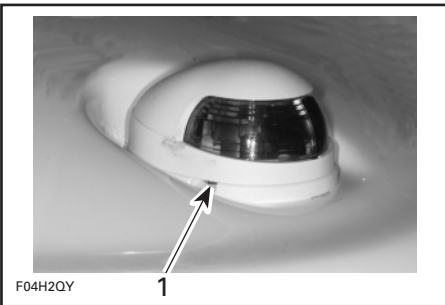

1. Gently pry here with a screwdriver

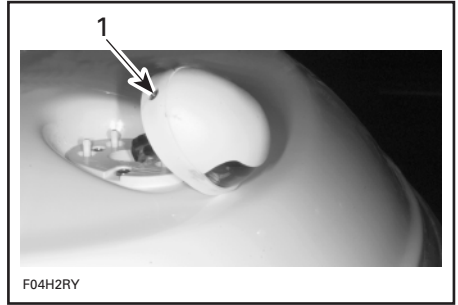

1. Remove this screw

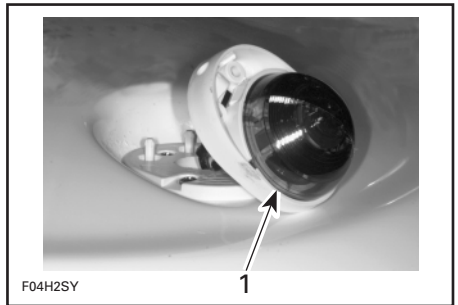

1. Pull lens out

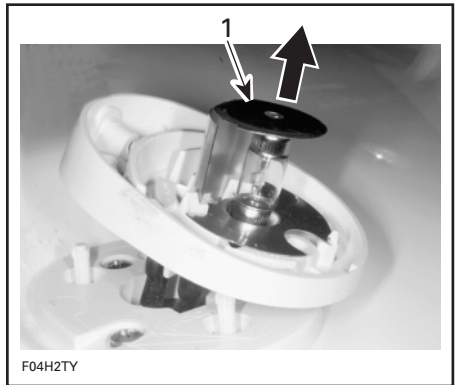

1. Lift and remove bulb

The assembly is essentially the reverse of removal procedures. However, pay particular attention to the following:

Apply dielectric grease on bulb contact surface.



When installing the bulb under the upper terminal plate, it is possible that the bulb remains loose. The cover will compress the terminal plate against the bulb at reinstallation.

### Stern Light

Unscrew lens counterclockwise and pull it out.

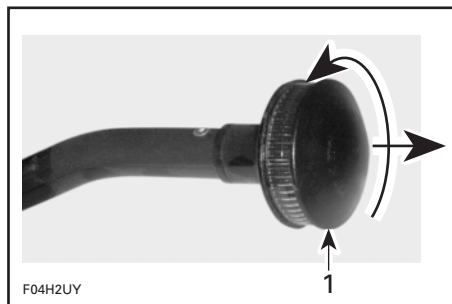

1. *Unscrew then pull*

Pull bulb to remove it.

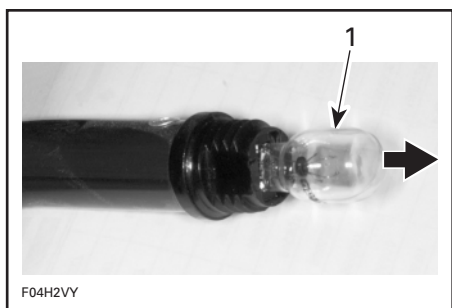

1. *Pull bulb out*

Apply dielectric grease on new bulb contact surface.

The assembly is the reverse of removal procedure.

## General Inspection and Cleaning

### Inspection

Check engine compartment for any damage and fuel/oil injection systems for leaks. Also check battery for electrolyte leaks. Ensure all hose clamps are properly secured and no hose is cracked, kinked or presenting any other damage.

### ◆ WARNING

If any gasoline leaks/odor are found, do not start the engines. Have the boat serviced by an authorized dealer.

Inspect mufflers, battery and reservoir fastening devices. Check electrical connections for corrosion and tightness.

Inspect hull and jet pump water intake grates for damage. Replace or have damaged parts repaired. It is recommended that an authorized dealer annually inspect the hull.

### Cleaning

Twice a year, the bilge should be cleaned with hot water and detergent or bilge cleaner to remove any possible fuel/oil/electrolyte deposits and mildew.

Occasionally, wash the body with hot water and soap (only use mild detergent). Remove any marine organisms from engine and/or hull. Apply non-abrasive wax.



## CAUTION

Never clean fiberglass and plastic parts with strong detergent, degreasing agent, paint thinner, acetone, etc.

Wash windscreen with Bombardier cleaner (P/N 293 110 001) and water. For fine scratches and scuff marks removal, use a windshield polisher for acrylic, lucite, polycarbonate and similar materials.

Respect the environment by ensuring fuel, oil or cleaning solutions do not drain into the waterways.

# TRANSPORTATION, STORAGE AND PRE-SEASON PREPARATION

## Transportation

### Trailer

Refer to the Trailer instructions for proper capacity, operation, maintenance, accessories and warranty.

Check the regulations in your area concerning towing a trailer, especially the following rules:

- Brake system
- Tow vehicle weight
- Mirrors

**NOTE:** An optional brake system is available for your trailer, see an authorized Sea-Doo Jet Boat dealer.

### Jet Boat

Take the following precautions when towing the jet boat.

<b>◆ WARNING</b>
Always turn the fuel valves to OFF position when transporting the jet boat.

Remove stern light (if installed).

Ensure all storage compartments are properly latched.

A SEA-DOO jet boat cover should protect the jet boat, particularly before driving on dirt roads.

### Boat Tie-down Attachment on Trailer

When securing boat tie-downs to trailer, ensure that tie-down hook is passed through trailer bracket hole as shown.

The hook open end must be toward ground so that if it would loosen, it would remain hooked on trailer bracket.

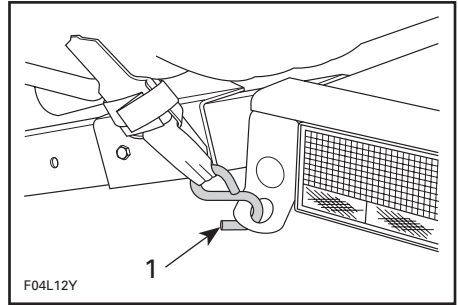

### TYPICAL

1. Hook open end must be positioned toward ground

<b>◆ WARNING</b>
Observe trailering safety precautions.

## Storage

It is recommended that the jet boat be taken to an authorized dealer for proper storage but the following operations can be performed by you with a minimum of tools.

<b>▼ CAUTION</b>
Do not run the engines during the storage period.

**NOTE:** Storage procedure applies for both engine systems where applicable.

## Engine Draining

Check engine drain tube. Make sure there is no sand or other particles in it and that it is not obstructed so that water can leave the engine. Clean hose and fitting as necessary.

▼ **CAUTION**

Water in engine drain tube must be free to flow out, otherwise water could be trapped in engine. Should water freeze in engine, severe damage will occur. Check engine drain tube for obstructions.

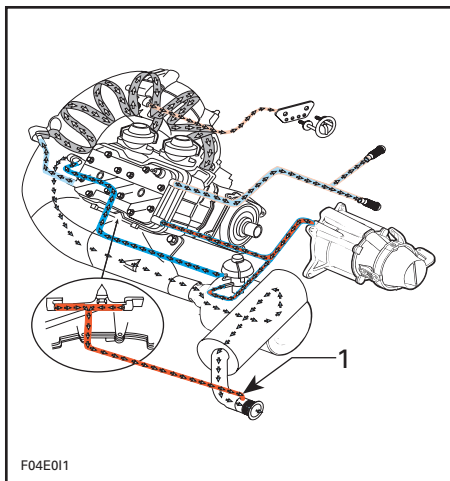

1. Drain tube must be cleaned

### Boat Rinsing

Thoroughly rinse the boat hull, bilge, engine compartment, with fresh water.

### Propulsion System

Lubricant in impeller shaft reservoir should be drained and reservoir cleaned. Refilled with 70 mL (2.5 oz) of BOMBARDIER synthetic polyolester oil 75W90 GL5 type C gear lube. Refer to an authorized dealer for this operation.

▼ **CAUTION**

Use only BOMBARDIER jet pump oil or equivalent synthetic gear oil, otherwise component service life could be reduced. Do not mix oil brands or types.

Lubricate PTO flywheel at grease fitting with synthetic grease.

▼ **CAUTION**

Do not lubricate excessively. Immediately stop when a slight movement is noticed on rubber boot. Never leave any clothing, tool or other objects in the engine compartment.

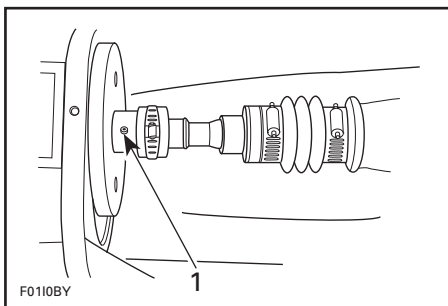

1. Grease PTO flywheel

### Fuel System

SEA-DOO fuel stabilizer or equivalent can be added to fuel tank to prevent fuel deterioration and carburetor gumming. Follow manufacturer's instructions for proper use.

▼ **CAUTION**

Fuel stabilizer should be added prior to engine lubrication to ensure carburetor protection against varnish deposit.

## ◆ WARNING

Fuel is flammable and explosive under certain conditions. Always work in a well ventilated area. Always wipe off any fuel spillage from the jet boat. Always turn the fuel valves to OFF position when storing the jet boat.

### Cooling System Flushing and Engine Internal Lubrication

Refer to procedure discussed in POST-OPERATION CARE.

### Battery

Contact your authorized dealer.

### Anticorrosion Treatment

Wipe off any residual water in the engine compartment.

Spray BOMBARDIER LUBE lubricant over metallic components in engine compartment.

### Additional Recommended Protection

In cool regions (where freezing point temperature may be encountered), cooling system should be filled with water and antifreeze solution. (50% water, 50% antifreeze).

## ▼ CAUTION

Always use ethylene glycol anti-freeze containing corrosion inhibitors specifically recommended for aluminum engines.

NOTE: The engines will not have to run during this operation but should have been run before to exhaust water from cooling system components.

Install a hose pincher and firmly tighten on the following hoses:

- Engine drain tube from cylinder base before T-fitting.
- Engine return hose right after T-fitting.
- Engine supply hose near cylinder head.

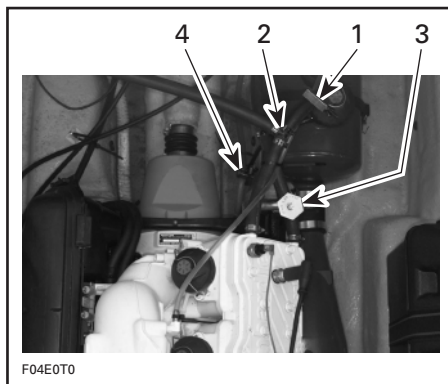

1. Hose pincher right after T-fitting
2. T-fitting
3. Hose pincher on engine supply hose
4. Hose pincher on drain hose

NOTE: Hose pinchers must be firmly tightened to avoid any flow of anti-freeze through the blocked hoses.

Unscrew cap and insert a funnel into the flushing fitting on the edge of engine compartment. Pour about 2 liters (1/2 gal) of antifreeze solution through the funnel. Let the antifreeze enough time to flow. Moving the hose with the T-fitting should accelerate the flow.

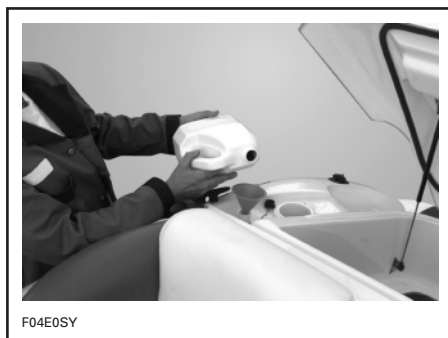

Pour antifreeze until it flows in tuned pipe bleed hose.



1. Pour antifreeze until it flows in bleed hose

When finished, remove all hose pinchers.

Most of the antifreeze will drain out when removing hose pinchers. Use a container to recover it. Dispose antifreeze as per your local laws and regulations.

**NOTE:** Although antifreeze will mainly drain out, the antifreeze has flowed to mix with water that was possibly trapped in cooling system cavities and thus preventing freezing problems.

**NOTE:** For pre-season preparation, drain antifreeze from cooling system prior to launching boat in water as explained above.

Repeat the same procedure for the other engine.

The following steps should be performed to provide the jet boat enhanced protection.

Lubricate the throttle cables with BOMBARDIER LUBE lubricant.

Clean the bilge with hot water and detergent or with bilge cleaner. Rinse thoroughly. Lift front end of jet boat to completely drain bilge. If any repairs are needed to the body or to the hull contact your dealer. For paint touch up to mechanical parts use Bombardier spray paint. For small gelcoat repairs, a Bombardier repair kit is available. Replace damaged labels/decals.

**NOTE:** Bilge cleaning should be done prior to anticorrosion treatment.

Wash the body and the trailer with soap and water solution (only use mild detergent). Rinse thoroughly with fresh water. Remove any marine organisms from the hull. Apply a non abrasive wax.

▼ **CAUTION**

Never clean fiberglass and plastic parts with strong detergent, degreasing agent, paint thinner, acetone, etc.

If the jet boat is to be stored outside, cover it with an opaque tarpaulin to prevent sun rays and grime from affecting the plastic components, jet boat finish as well as preventing dust accumulation.

▼ **CAUTION**

Never leave the jet boat stored in direct sunlight. UV radiation will dull finishes. The jet boat must never be left in water for storage. Make sure to turn off bilge pump and blower.

The engine storage cover should be left partially opened during storage (disconnect the gas shocks from the cover to prevent full opening). Remove storage tray. Place it on deck. This will avoid engine compartment condensation and possible corrosion.

---

For the storage period, it is necessary to lift the bow up and safely block in this position so drainage can take place. Unscrew the drain plug.

## **Pre-Season Preparation**

Use the following chart.

Since technical skills and special tools are required, some operations should be performed by an authorized dealer.



### **WARNING**

Observe WARNINGS and CAUTIONS mentioned throughout this guide which are pertinent to the item being checked. When component conditions seem less than satisfactory, replace with genuine BOMBARDIER parts or approved equivalents.

## Pre-Season Preparation Chart

**NOTE:** It is highly recommended that the dealer perform at the same time the annual safety inspection in addition to the pre-season preparation.

OPERATIONS	TO BE PERFORMED BY
Lubrication/corrosion protection	OPERATOR
DESS operation/DESS post and safety lanyard cap terminal condition	DEALER
Battery condition/charging and reinstallation	DEALER
Starter connections and routing ②	DEALER
Spark plug replacement ①	OPERATOR
Impeller shaft reservoir oil inspection/replacement	DEALER
Propulsion and weedless system inspection	DEALER
Sacrificial zinc anodes	DEALER
Oil filter replacement	DEALER
Oil injection reservoir filling	OPERATOR
Flame arrester cleaning/inspection ②	DEALER
Fuel filter replacement	DEALER
Fuel line condition ②	DEALER
Filler neck, fuel tank and fuel cap condition ②	DEALER
Check valves, fasteners, fuel system pressurization ②	DEALER
Choke cable inspection/adjustment	DEALER
Oil injection pump adjustment and bleeding	DEALER
Engine ignition timing	DEALER
Carburetor adjustment	DEALER
Steering system and docking assistance system inspection ②	DEALER
Throttle/shifter system inspection ②	DEALER
Inspection of drain hole/bilge pump/drain plug	DEALER
Inspection of cooling system inlet/outlet hoses ②, monitoring beeper	DEALER
Fire extinguisher condition/mounting ②	OPERATOR

① Before installing new spark plugs, it is suggested to burn the excess BOMBARDIER LUBE lubricant by starting the engines using the old spark plugs.

② Safety item covered in the annual safety inspection.

### **WARNING**

Only perform this operation in a well ventilated area. Garden hose must be installed or boat must be in water to cool engine. Running the engine without cooling water will damage exhaust hose interior and may damage engine.



# TROUBLESHOOTING

The following chart is provided to help in diagnosing the probable source of simple troubles. You may be able to solve many of these problems rather quickly, but others may require the skills of a mechanical technician. In such a case, consult an authorized dealer for servicing.

## Monitoring Beeper Coded Signals

NUMBER OF BEEPS	POSSIBLE CAUSE	REMEDY
2 short (while installing safety lanyard on DESS post).	<ul style="list-style-type: none"> <li>Everything is correct with the safety lanyard (good contact and right lanyard cap).</li> </ul>	<ul style="list-style-type: none"> <li>Engine can be started normally.</li> </ul>
1 long (while installing safety lanyard on DESS post or when pressing start/stop buttons in some cases).	<ul style="list-style-type: none"> <li>Bad connection between safety lanyard cap and DESS post.</li> <li>Wrong safety lanyard.</li> <li>Dried salt water or oil in safety lanyard cap.</li> <li>Improper operation of MPEM or defective wiring harness.</li> </ul>	<ul style="list-style-type: none"> <li>Remove and reinstall the safety lanyard on the DESS post. Two short beeps should be heard which indicates the system is ready again to allow engine starting.</li> <li>Use the safety lanyard that has been programmed for the boat. If it does not work, refer to an authorized dealer.</li> <li>Clean safety lanyard cap.</li> <li>Refer to an authorized dealer.</li> </ul>
4 short (while pressing start/stop button with safety lanyard already installed).	<ul style="list-style-type: none"> <li>Shifter is NOT in neutral.</li> </ul>	<ul style="list-style-type: none"> <li>Place shifter in neutral. While moving the shifter, 1 short beep indicates you reached the neutral position.</li> </ul>
1 short (while moving shifter to neutral).	<ul style="list-style-type: none"> <li>Confirmation that shifter is now in <b>neutral</b>.</li> </ul>	<ul style="list-style-type: none"> <li>Engine is now ready to be started.</li> </ul>
8 short.	<ul style="list-style-type: none"> <li>Defective MPEM (memory).</li> </ul>	<ul style="list-style-type: none"> <li>Refer to an authorized dealer.</li> </ul>
Continuous.	<ul style="list-style-type: none"> <li>Engine overheating.</li> </ul>	<ul style="list-style-type: none"> <li>Refer to Engine Overheats below.</li> </ul>

## Engine will not Start

OTHER OBSERVATION	POSSIBLE CAUSE	REMEDY
Engine does not turn over and the monitoring beeper sounds	Refer to monitoring beeper coded signals above.	
Engine does not turn over.	<ul style="list-style-type: none"> <li>• Safety lanyard removed.</li> <li>• Burnt fuse.</li>   <li>• Discharged battery.</li> <li>• Battery connections, corroded or loose.</li> <li>• Water flooded engine.</li> </ul>	<ul style="list-style-type: none"> <li>• Install cap over switch.</li> <li>• Check wiring then replace fuse.</li> <li>• Refer to an authorized dealer.</li> <li>• Refer to an authorized dealer.</li>   <li>• Refer to an authorized dealer.</li> </ul>
Engine slowly turns.	<ul style="list-style-type: none"> <li>• Discharged or weak battery.</li> </ul>	<ul style="list-style-type: none"> <li>• Refer to an authorized dealer.</li> </ul>
Engine turns over.	<ul style="list-style-type: none"> <li>• Fuel tank empty or water contaminated.</li> <li>• Fuel filter clogged or water contaminated.</li> <li>• Fuel flooded engine:               <ul style="list-style-type: none"> <li>- Fouled/defective spark plugs.</li> <li>- Misuse of choke.</li> </ul> </li> </ul>	<ul style="list-style-type: none"> <li>• Refill or siphon and fill with fresh fuel.</li> <li>• Clean, check fuel tank for water.</li>   <li>• Replace.</li>   <li>• Use only with cold engine. Replace spark plugs.</li> </ul>

## Engine Misfires, Runs Irregularly

OTHER OBSERVATION	POSSIBLE CAUSE	REMEDY
Weak spark.	<ul style="list-style-type: none"> <li>• Fouled worn spark plugs.</li> <li>• Faulty RPM limiter.</li> <li>• Too much oil supplied to engine.</li> </ul>	<ul style="list-style-type: none"> <li>• Replace.</li> <li>• Refer to an authorized dealer.</li>   <li>• Improper oil pump adjustment, refer to an authorized dealer.</li> </ul>
Lean fuel mixture.	<ul style="list-style-type: none"> <li>• Fuel: Level too low, stale or water contaminated.</li> <li>• Fuel filter, clogged or water contaminated.</li> <li>• Fuel valve partially opened.</li> </ul>	<ul style="list-style-type: none"> <li>• Siphon and/or refill.</li>   <li>• Refer to an authorized dealer.</li>   <li>• Turn fuel valve to ON position.</li> </ul>
Rich fuel mixture (high fuel consumption).	<ul style="list-style-type: none"> <li>• Flame arrester dirty/clogged.</li> <li>• Partially closed choke.</li> </ul>	<ul style="list-style-type: none"> <li>• Clean or replace.</li>   <li>• Refer to an authorized dealer.</li> </ul>

## Engine Overheats

OTHER OBSERVATION	POSSIBLE CAUSE	REMEDY
Monitoring beeper continuously sounds.	<ul style="list-style-type: none"> <li>• Clogged jet pump water intake.</li> <li>• Incorrect type of fuel or oil.</li> <li>• Clogged coolant system.</li> </ul>	<ul style="list-style-type: none"> <li>• Clean.</li>   <li>• Siphon and refill.</li> <li>• Flush cooling system with garden hose.</li> </ul>

---

## Engine Continually Backfires

OTHER OBSERVATION	POSSIBLE CAUSE	REMEDY
	<ul style="list-style-type: none"><li>• Faulty RPM limiter.</li></ul>	<ul style="list-style-type: none"><li>• Refer to an authorized dealer.</li></ul>
Weak spark.	<ul style="list-style-type: none"><li>• Fouled, worn spark plugs.</li></ul>	<ul style="list-style-type: none"><li>• Replace.</li></ul>
Overheated engine.	<ul style="list-style-type: none"><li>• See ENGINE OVERHEATS.</li></ul>	

## Engine Pinging or Knocking

OTHER OBSERVATION	POSSIBLE CAUSE	REMEDY
	<ul style="list-style-type: none"><li>• Poor quality gasoline/low octane.</li><li>• Spark plug heat range too high.</li></ul>	<ul style="list-style-type: none"><li>• Use well known quality and recommended gasoline.</li><li>• Use recommended spark plugs.</li></ul>

## Engine Lacks Acceleration or Power

OTHER OBSERVATION	POSSIBLE CAUSE	REMEDY
	<ul style="list-style-type: none"><li>• Weak spark/incorrect fuel mixture.</li><li>• Water in fuel or injection oil.</li></ul>	<ul style="list-style-type: none"><li>• Refer to ENGINE MISFIRES...</li><li>• Siphon and replace.</li></ul>
Overheated engine.	<ul style="list-style-type: none"><li>• See ENGINE OVERHEATS.</li></ul>	

## Jet Boat can not Reach Top Speed

OTHER OBSERVATION	POSSIBLE CAUSE	REMEDY
	<ul style="list-style-type: none"><li>• Jet pump water intakes clogged.</li><li>• Damaged impeller(s).</li></ul>	<ul style="list-style-type: none"><li>• Clean.</li><li>• Replace. Refer to an authorized dealer.</li></ul>

## Abnormal Noise from Propulsion System

OTHER OBSERVATION	POSSIBLE CAUSE	REMEDY
	<ul style="list-style-type: none"><li>• Weeds or debris jammed around impeller(s).</li></ul>	<ul style="list-style-type: none"><li>• Clean and check for damage.</li></ul>
	<ul style="list-style-type: none"><li>• Damaged impeller shaft(s) or drive shaft(s).</li></ul>	<ul style="list-style-type: none"><li>• Refer to an authorized dealer.</li></ul>

# SPECIFICATIONS

<b>ENGINE</b>		<b>CHALLENGER 1800 (5600/5601)</b>
Number of engines		2
Engine type		Bombardier-Rotax 787, 2-stroke
Induction type		Rotary valve
Exhaust system		Water cooled/water injected
Lubrication	Type	Oil injection
	Oil type	BOMBARDIER ROTAX INJECTION OIL
Number of cylinders		2
Displacement		782 cm <sup>3</sup> (47.69 in <sup>3</sup> )
Rev limiter setting		7200 RPM (± 50)
<b>COOLING</b>		
Type		Water cooled, total loss type. Direct flow from propulsion unit.
Monitoring beeper		96-99°C (205-210°F)
<b>ELECTRICAL</b>		
Magneto generator output		180 W @ 6000 RPM
Ignition system type		DC-CDI (Direct-Current Capacitor Discharge Ignition (breakerless))
Spark plug	Make and type	NGK, BR8ES (resistor type)
	Gap	0.5 - 0.6 mm (.020 - .024 in)
Starting system		Electric starter
Battery		Not supplied ①
Fuses	Fuse block supply	20 A
	MPEM supply	2 x 5 A
	Charging system	2 x 15 A
	Bilge Blower	7.5 A
	Bilge pump	3 A
	Gauges	7.5 A
	Navigation Lighting	7.5 A
Auxiliary system		10 A
<b>CARBURETION</b>		
Fuel type		Regular unleaded gasoline
Carburetor		Diaphragm type with acceleration pump, quantity: 2

① Recommended: Exide RV24-130, 12 V, 25 A•h (130 minutes reserve) or RV24-160 (160 minutes) or equivalent.

Battery posts: On top. Round taper type.

Battery maximum allowed size: 285 mm (11-1/4") long x 190 mm (7-1/2") wide x 238 mm (9-3/8") high.

<b>PROPULSION</b>		<b>CHALLENGER (5600/5601)</b>
Propulsion system		Bombardier Formula Jet Pump
Number of jet pumps		2
Jet pump type		Axial flow, single stage
Transmission		Direct drive
Impeller shaft reservoir, oil type		Sea-Doo Synthetic polyolester 75W90 GL5 gear oil
Pivoting angle of direction (nozzle)		~26°
Minimum required water level for jet pump(s)		90 cm (3 ft)
<b>DIMENSIONS</b>		
Number of passengers		7 ①
Overall length		540 cm (212.5 in)
Overall length on trailer		610 cm (240 in)
Beam		235 cm (92.5 in)
Dead rise		19.5°
Overall height		135 cm (53 in)
Overall height on trailer		178 cm (70 in)
Weight (dry)		900 kg (1984 lb)
Load limit (passengers + luggage)		500 kg (1100 lb) ②
Hull material		Composite (fiberglass)
<b>CAPACITIES</b>		
Fuel tank (reserve included)		151 L (40 U.S. gal)
Impeller shaft reservoir	Capacity	70 mL (2.5 U.S. oz)
	Oil level	Up to plug
Oil injection reservoir		9 L (2.4 U.S. gal)

① Refer to load limits.

② The load limit is based on calm water conditions.

BOMBARDIER INC. reserves the right to make changes in design and specifications and/or to make additions to, or improvements in its products without imposing any obligation upon itself to install them on its products previously manufactured.

# SI\* METRIC INFORMATION GUIDE

## BASE UNITS

DESCRIPTION	UNIT	SYMBOL
length .....	meter .....	m
mass .....	kilogram .....	kg
force .....	newton .....	N
liquid .....	liter .....	L
temperature .....	Celsius .....	°C
pressure .....	kilo pascal .....	kPa
torque .....	newton-meter .....	N•m
land velocity .....	kilometer per hour .....	km / h
navigation velocity .....	knot .....	kn

## PREFIXES

PREFIX	SYMBOL	MEANING	VALUE
kilo .....	k .....	one thousand .....	1000
centi .....	c .....	one hundredth of .....	0.01
milli .....	m .....	one thousandth of .....	0.001
micro .....	μ .....	one millionth of .....	0.000001

## CONVERSION FACTORS

TO CONVERT	TO ①	MULTIPLY BY
in .....	mm .....	25.4
in .....	cm .....	2.54
in <sup>2</sup> .....	cm <sup>2</sup> .....	6.45
in <sup>3</sup> .....	cm <sup>3</sup> .....	16.39
ft .....	m .....	0.3
oz .....	g .....	28.35
lb .....	kg .....	0.45
lbf .....	N .....	4.4
lbf•in .....	N•m .....	0.11
lbf•ft .....	N•m .....	1.36
lbf•ft .....	lbf•in .....	12
PSI .....	kPa .....	6.89
imp. oz .....	U.S. oz .....	0.96
imp. oz .....	mL .....	28.41
imp. gal .....	U.S. gal .....	1.2
imp. gal .....	L .....	4.55
U.S. oz .....	mL .....	29.57
U.S. gal .....	L .....	3.79
knot .....	MPH .....	1.15
MPH .....	km / h .....	1.61
Fahrenheit .....	Celsius .....	(°F - 32) ÷ 1.8
Celsius .....	Fahrenheit .....	(°C × 1.8) + 32
hp .....	kW .....	.75

\* The international system of units abbreviates SI in all languages.

① To obtain the reverse sequence, divide by the given factor. To convert "millimeters" to "inches", divide by 25.4.

**NOTE:** Conversion factors are rounded off to 2 decimals for easier use.









STAMP

**BOMBARDIER INC.**  
SEA-DOO WARRANTY  
VALCOURT, QUEBEC  
CANADA J0E 2L0