

SEA-DOO



Operator's Guide

219 000 017

SAFETY WARNING

Disregarding any of the safety precautions and instructions contained in this *Operator's Guide*, the *Safety Handbook* and on *Product Warnings* could cause injury, including the possibility of death.

This *Operator's Guide* and the *Safety Handbook* should remain with the watercraft at the time of resale.

AFTER SALES SERVICE
BOMBARDIER INC.
VALCOURT (QUÉBEC)
CANADA JOE 2L0



The following trademarks are property of
Bombardier Inc. :

SEA-DOO®

Sea-Doo Lube®

Sea-Doo Jet Pump Synthetic Oil

Sea-Doo Synthetic Grease

Gelcote® is a trademark of Gelcote International

Doin'it on your new Sea-Doo Watercraft

Nowadays it seems that everywhere you look, everybody's Doin'it. Folks are Doin'it with their friends, and friends are Doin'it with their folks. And right now, everyone at Sea-Doo would like to say, "Welcome aboard, we're glad that you're Doin'it too."

As a new member of the Sea-Doo club, please read this *Operator's Guide* and *Safety Handbook* and follow the instructions for safe, responsible and courteous riding. This will help protect the value of your investment as well as the safety of you and your passengers. Remember, you're now the skipper of a Class A motorboat. And as such, you're responsible for the safety of anyone riding your boat, as well as any damage that may occur from your wake.

When introducing your family and friends to the sport, be sure they understand the importance of courteous, responsible riding. By operating your Sea-Doo watercraft with regard for the rights and safety of other boaters, skiers, fishermen and swimmers, you make it possible for others to continue to enjoy the sport.

Finally, please visit your Sea-Doo dealer regularly for maintenance, parts and accessories. Bon voyage!

TABLE OF CONTENTS

FOREWORD	4
SAFETY	5
About the Navigation Laws and Regulations	5
Watercraft Operation	6
Maintenance	7
SEA-DOO WATERCRAFT LIMITED WARRANTY (NORTH AMERICAN)	8
LIST OF DISTRIBUTORS	10
WARRANTY QUESTIONS AND ANSWERS	11
Customer Service	12
REGISTRATION NUMBER LOCATION	13
IDENTIFICATION OF COMPONENTS	14
Identification Numbers	14
Controls and Components Location	15
FUEL AND LUBRICATION	24
Recommended Fuel	24
Recommended Oil	24
Oil Injection System	25
BREAK-IN PERIOD	26
Engine	26
10-Hour Inspection	26
DAILY PRE-OPERATION CHECKS	28
Hull	28
Jet Pump Water Intake	28
Bilge	29
Battery	29
Fuel / Oil Reservoirs	29
Engine Compartment	29
Fire Extinguisher	29
Steering / Throttle Systems	29
Reverse System	29
Safety Lanyard / Engine Stop Button	29
Inflatable Tube	29
Clothing	30
Obstacles	30
OPERATING INSTRUCTIONS	31
Principle of Operation	31
Boarding from a Dock or in Shallow Water	32
Starting the Engine	32
Boarding in Deep Water	33
Rough Water Operation	34
Crossing Waves	34
Stopping / Docking	34

Beaching	35
Shutting Off the Engine	35
POST-OPERATION CARE	36
General Care	36
Additional Care for Foul Water or Salt Water	36
SPECIAL PROCEDURES	39
Engine Overheat	39
Jet Pump Water Intake and Impeller Cleaning	39
Capsized Watercraft	40
Submerged Watercraft	40
Towing the Watercraft	40
Low-Charge Battery Condition	40
MAINTENANCE	41
Lubrication	41
Periodic Inspection	43
Periodic Inspection Chart	44
Throttle and Choke Cable Inspection	45
Carburetor Adjustment	45
Fuel and Oil Filters	45
Steering / Jet Pump Nozzle Adjustment	45
Reverse Gate Adjustment	45
Vacuum Bailer Pick-Ups and Deck Drain Holes	46
Fuses	46
Air Blower	47
Zinc Anode	47
Tube Inflation	47
Order of Inflation	48
Tube Deflation	48
Minor Repairs	48
General Inspection and Care	49
TRANSPORTATION, STORAGE AND PRE-SEASON PREPARATION	50
Transportation	50
Storage	50
Pre-Season Preparation	53
TROUBLESHOOTING	55
SPECIFICATIONS	57
SI METRIC INFORMATION GUIDE	59
ACCESSORIES AND SERVICE PRODUCTS	60
OTHER PUBLICATIONS AVAILABLE	63

FOREWORD

The *Operator's Guide* and *Safety Handbook* have been prepared to acquaint the owner / operator or passenger of this watercraft with the various watercraft controls, maintenance and safe riding instructions. Each is indispensable for the proper use of the product, and should be kept in a waterproof bag with the watercraft at all times.

For any questions pertaining to the warranty and its application, please consult the WARRANTY QUESTIONS AND ANSWERS section in this guide, or an authorized SEA-DOO dealer.

This guide uses the following symbols to emphasize particular information.

◆ **WARNING** : Identifies an instruction which, if not followed, might cause serious personal injuries including the possibility of death.

▼ **CAUTION** : Denotes an instruction which, if not followed, might severely damage the watercraft and / or components.

○ **NOTE** : Indicates supplementary information needed to fully complete an instruction.

Although the mere reading of such information does not eliminate the hazard, the understanding and application of the information will promote its correct use.

The information and components / system descriptions contained in this guide are correct at the time of publication. Bombardier Inc. however, maintains a policy of continuous improvement of its products without imposing upon itself any obligation to install them on products previously manufactured.

Bombardier Inc. reserves the right at any time to discontinue or change specifications, designs, features, models or equipment without incurring obligation.

The illustrations show the typical construction of the different assemblies and may not represent the full detail or exact shape of the parts which have the same or a similar function.

Specifications are given in the SI metric system with the SAE U.S. equivalent in parenthesis. Where precise accuracy is not required, some conversions are rounded off for easier use.

A *Shop Manual* can be obtained for complete service, maintenance and repair information.

◆ **WARNING** : The engines and the corresponding components identified in this guide should not be utilized on product(s) other than those it is designed for. Maintenance procedures and specified tightening torques must be strictly adhered to. Never attempt repairs unless the appropriate tools are available. This watercraft is designed with parts dimensioned in both the metric and the imperial systems. When replacing fasteners, make sure to use only those recommended by Bombardier. Mismatched or incorrect fasteners could cause damage to the watercraft or possible personal injury.

SAFETY

PLEASE READ AND UNDERSTAND ALL WARNINGS AND CAUTIONS IN THIS GUIDE, ON THE WATERCRAFT AND IN THE *SAFETY HANDBOOK*.

Prior to operating the watercraft, thoroughly read and understand the *Operator's Guide*, it will give necessary knowledge required to adequately operate this watercraft.

About the Navigation Laws and Regulations

- ◆ Check local and federal boating laws and regulations in the area where the watercraft is to be used. It is recommended to follow a boating safety course.

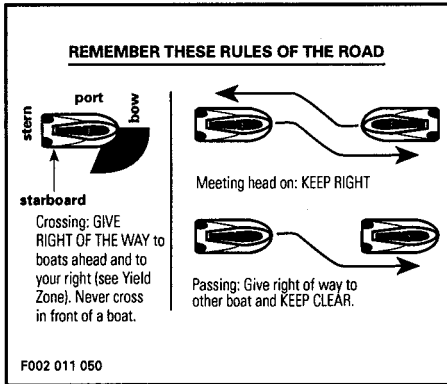

- ◆ Operator and passengers must always wear a Personal Flotation Device (PFD). It is recommended to use gloves, deck shoes / booties, protective glasses and a wet suit to help protect users against possible injuries.

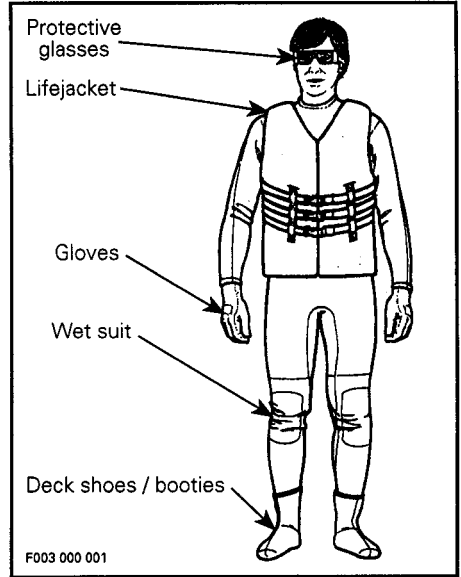

- ◆ An approved fire extinguisher must be present in the watercraft (space is provided in rear storage compartment).
- ◆ Operation by an unqualified minor is not recommended. A responsible adult should instruct and supervise a minor operating the watercraft.
- ◆ This watercraft is not designed for night-time operation (if optional lighting system is not installed).
- ◆ Never operate the watercraft after consuming alcohol and / or drugs.
- ◆ A sound signalling device, such as a whistle, must be fastened to your Personal Flotation Device (PFD).

Watercraft Operation

- ◆ For safety reasons and proper care, always perform DAILY PRE-OPERATION CHECKS as specified in this guide before operating the watercraft.
- ◆ Operator should be sitting on the watercraft and firmly holding the handlebar before starting the engine.
- ◆ Always securely attach the safety lanyard to the operator's PFD.
- ◆ Throttle and steering mechanisms must be checked for free movement before starting engine.
- ◆ Check fuel/oil levels and battery condition before operating the watercraft.
- ◆ When starting or operating the engine, do not touch any electrical part.
- ◆ The watercraft engine is stopped by pressing the engine stop button until engine stops or by pulling the safety lanyard. If the engine is stopped because of an equipment malfunction, the source of this malfunction should be determined and corrected before restarting the engine.

Watercraft should not be operated in less than 90 cm (3 ft) of water. Otherwise damage may occur to watercraft.

Do not run the watercraft to the beach. Refer to OPERATING INSTRUCTIONS under **Beaching** in this guide.

- ◆ Do not allow passenger(s) to sit on tube while watercraft is in operation.
- ◆ Fuel vapors can explode. Before starting engine operate blower for four minutes and check engine compartment bilge for gasoline vapors. Blower must be turned off during watercraft operation.

- ◆ It is not recommended to operate the watercraft within or around the surfline.
- ◆ Be careful before beginning a sharp turn, other craft operators may not expect that this watercraft can turn quickly.
- ◆ Always keep in mind that as the throttle lever is released, less directional control will be available. At idle or engine stop, there is no directional control. To turn the watercraft, steering must be turned and throttle applied.
- ◆ The operator should practice solo operation prior to giving a ride to a passenger(s).
- ◆ Watercraft carrying capacity is 474 kg (1045 lb). Riding with passenger(s) makes the watercraft handle differently and requires greater skill.

Always check injection oil reservoir level when refueling.

- ◆ The operator and passengers should keep their feet in the watercraft. The passengers should always hold a grab handle.
- A towrope should be kept at all time in the watercraft storage compartment.
- ◆ Always stop engine before refueling. Fuel is highly flammable and explosive under certain conditions. Refuel in a well ventilated area. Never refuel while smoking or in vicinity of open flame. If fuel fumes are noticed, the cause should be determined and corrected without delay.
 - ◆ When the engine is running, be careful not to have hands, feet or any part of clothing close to the jet pump water intake.

- ◆ To prevent accidental engine starting, always remove safety lanyard, particularly when cleaning jet pump water intake area. Never insert any object in the jet pump water intake or outlet.
- ◆ An inexperienced operator should practice how to get aboard close to shore first before venturing into deep water.
- ◆ Wave or wake jumping is dangerous and may be illegal.
- ◆ Unless in an emergency, do not perform 180° or 360° turns at speed.
- ◆ Watch for dangerous near-surface or underwater obstacles / rocks / weeds particularly while riding in shallow water.
- ◆ Do not operate near swimmers.
- ◆ When riding far it is recommended to be accompanied by another craft. Watch for and keep a safe distance from other craft. Do not attempt to SPLASH other craft or people.

Maintenance

After salt water use, particular care and lubrication have to be performed to neutralize salt action on watercraft and components. Refer to POST-OPERATION CARE under **Additional Care for Foul Water or Salt Water** in this guide.

Since the engine cooling is in effect only when the watercraft is in the water, it is not recommended that the engine be allowed to idle for more than one minute without water supply. Prolonging such idling might cause engine damage.

When inspecting the hull / jet pump, always rotate watercraft **counterclockwise** (seen from the rear). Rotating watercraft clockwise could allow residual water in the tuned pipe to enter the engine and cause engine damage.

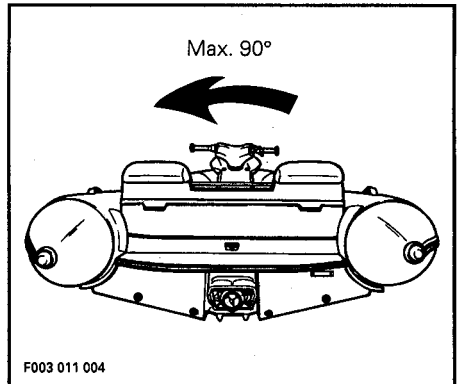

Should water get into the engine, immediately follow the procedure pertaining to **Submerged Watercraft** in the SPECIAL PROCEDURES section as specified in this guide. Should water be left in the engine for more than a few hours, engine internal parts will be damaged.

- ◆ Maintain the watercraft in top mechanical condition at all times.
- ◆ Installation of parts other than original equipment is not recommended. Avoid adding on accessories that alter the basic watercraft configuration including change in components location, altering vent tubes, etc.

Whenever the watercraft is left outdoors for a long period, it is strongly recommended to protect the watercraft from the weather with a SEA-DOO cover.

- ◆ Only perform procedures as detailed in this guide. Unless otherwise specified, engine must be turned off and safety lanyard removed from switch for all maintenance.
- ◆ Should removal of a locking device be required when undergoing repair / disassembly, always replace with new ones. Tighten fasteners as specified in the applicable *Shop Manual*.

SEA-DOO® WATERCRAFT LIMITED WARRANTY (NORTH AMERICAN)

(MODEL 5870 / 5871 / 5872 / 5814 / 5862 / 5854 / 5821)

1 - PERIOD

BOMBARDIER® INC. as manufacturer, warrants FROM THE DATE OF FIRST CONSUMER SALE, every SEA-DOO Watercraft, models 5870 / 5871 / 5872 / 5814 / 5862 / 5854 and 5821, sold as NEW, UNUSED, and predelivered by an authorized NORTH AMERICAN SEA-DOO Watercraft dealer for a period of :

- 12 consecutive months for private use owners.
- 90 consecutive days for commercial use owners.
- All optional Bombardier accessories when initially installed at the time of sale or delivery, carry the same warranty duration as the watercraft.
- Optional accessories installed after the date of delivery of the watercraft, carry the 90-days parts / accessories warranty.

2 - WHAT BOMBARDIER WILL DO

BOMBARDIER will repair and / or replace, at its option original and genuine Bombardier components found defective in material and / or workmanship (under normal use and service), with a genuine BOMBARDIER component without charge for parts or labor, at any authorized NORTH AMERICAN SEA-DOO dealer during said warranty period. All parts replaced under warranty become the property of BOMBARDIER INC.

3 - CONDITIONS TO HAVE WARRANTY WORK PERFORMED

Present to the servicing dealer, the BOMBARDIER warranty registration card or proof of purchase received from the selling dealer at time of purchase.

4 - EXCLUSIONS - ARE NOT WARRANTED

- Normal wear on all items such as, but not limited to :
 - Impellers, spark plugs, fuel filters
 - Gel coat stress cracks
- Damage caused by failure to provide proper maintenance as detailed in the *Operator's Guide*. The labor, parts and lubricants costs of all maintenance services, including tune-ups or adjustments will be charged to the owner.
- Damage resulting from running the watercraft out of the water.
- Damage resulting from improper repairs, modification, racing or use of non-approved parts.
- Losses incurred by the watercraft owner other than the parts and labor, such as, but not limited to, transportation, towing, telephone calls, taxis or any other incidental or consequential damage.
- Damage resulting from accident, fire or other casualty, misuse, abuse or neglect.
- Damage / rust / corrosion / premature wear caused by water ingestion or sand / stone infiltration, or cavitation.

5 - EXPRESSED OR IMPLIED WARRANTIES

This warranty gives you specific rights, and you may also have other legal rights which may vary from state to state, or province to province.

Where applicable this warranty is expressly in lieu of all other expressed or implied warranties of BOMBARDIER, its distributors and the selling dealer, including any warranty of merchantability or fitness for any particular purpose : otherwise the implied warranty is limited to the duration of the warranty. However, some states or provinces do not allow limitations on how long an implied warranty lasts, so the above limitations may not apply.

Neither the distributor, the selling dealer, nor any other person has been authorized to make any affirmation, representation or warranty other than those contained in this warranty, and if made, such affirmation, representation or warranty shall not be enforceable against BOMBARDIER or any other person.

Some states or provinces do not allow the exclusion or limitation of incidental or consequential damages, so the above limitation or exclusion may not apply.

BOMBARDIER INC. reserves the right to modify its warranty policy at any time, being understood that such modification will not alter the warranty conditions applicable to watercraft sold while the above warranty is in effect.

6 - CONSUMER ASSISTANCE PROCEDURE

If a servicing problem or other difficulty occurs, we suggest the following :

1. Try to solve the problem at the dealership with the Service Manager or Owner.
2. If not possible, contact the area distributor listed in your *Operator's Guide*.

BOMBARDIER INC.

Valcourt, Québec,
Canada J0E 2L0

September 1st, 1993

®*Trademarks of Bombardier Inc.

LIST OF DISTRIBUTORS

NORTH AMERICA

U.S.A.: (Continental U.S.A. except Alaska, Hawaii and Puerto Rico)	BOMBARDIER CORPORATION 7575 BOMBARDIER COURT P.O. BOX 8035 WAUSAU, WI 54402-8035 Phone : (715) 842-8886
Alaska	THE BRYANT CORPORATION 19011 Woodville Snow Road P.O. BOX 389 WOODINVILLE, WA 98072 Phone : (206) 483-0110
CANADA : Ontario Québec	BOMBARDIER INC. SEA-DOO SERVICE DEPARTMENT VALCOURT, QUÉBEC CANADA J0E 2L0 Phone : (514) 532-2211
Alberta British Columbia Manitoba North West Territories Saskatchewan Yukon	BROOKS EQUIPMENT LTD 1616 KING EDWARD ST. P.O. BOX 985 WINNIPEG, MANITOBA R3C 2V8 Phone : (204) 633-7247
New-Brunswick Newfoundland Nova Scotia Prince Edward Island	BELL-CHARLES R. P.O. BOX 1050 RIVERSIDE DRIVE CORNER BROOKE, NFLD A2H 6J3 Phone : (709) 634-3533

To find the nearest authorized Sea-Doo dealer, dial : 1-800-882-2900.

WARRANTY QUESTIONS AND ANSWERS

Q. Why must my watercraft be registered at the factory ? After all I do have my original invoice as proof of when I purchased my watercraft.

A. *Your warranty is valid at any authorized dealer of the product. Your registration is the key element in providing the servicing dealer with the necessary data to complete warranty claim forms.*

The federal government requires each manufacturer and dealer to maintain a complete up-to-date list of all first purchasers in case of a safety-related defect and recall. This list is compiled from the warranty registrations sent to BOMBARDIER INC. by the selling dealer at the time of your purchase. If you have a change of address after the purchase of your new SEA-DOO, please advise us of your new address by sending the Change of Address / Ownership Card in this book or, a postcard listing your model number, dealer number (or dealer's name) as it is shown on your warranty card, your name and new mailing address.

Q. What costs are my responsibility during the warranty period ?

A. *The customer's responsibility includes all costs of normal maintenance services, non-warranty repairs, accident and collision damage.*

Q. What is cavitation ?

A. *This phenomenon is caused by a part travelling at high speed in a fluid (ex. : an impeller in water). The heat / bubbles generated in some areas are enough to draw microscopic particles from the material. Cavitation will increase if there are scratches or dents in the housing / impeller or if the wear ring is worn.*

Q. Does warranty cover the jet drive system components ?

A. *Yes, if components replacement is not due to cavitation or normal wear. Ex. : The impeller has to be considered a wear item since tiny particles and sand contained in the water will eventually cause some wear. This situation occurs most often when the watercraft is driven in shallow water where rocks and debris can be drawn into the pump.*

In order to extend the service life of the impeller housing, we have developed a replaceable wear ring around the impeller. It is made of plastic, therefore it may wear with use and should be replaced. This is a convenient feature and inexpensive to replace. This replacement is considered normal maintenance and not covered by warranty.

Q. What are some examples of neglect or abuse ?

A. *These terms are general and overlap each other in areas. Specific examples include ; the engine running out of oil, operating the watercraft with a broken or damaged part, which causes another part to fail and so on. If you have any specific questions on operation or maintenance, please contact your SEA-DOO watercraft dealer for advice.*

Q. Does the warranty cover incidental costs such as transportation due to a failure ?

A. *No. The warranty is limited to the repair of the SEA-DOO watercraft itself.*

Q. May I perform any or all of the recommended maintenance shown in the *Operator's Guide* instead of having the dealer do them ?

A. *Yes, if you are a qualified mechanic and follow the procedures specified in the Operator's Guide and Shop Manual. We do recommend however that the critical adjustments to timing and carburetion be done by a SEA-DOO dealer.*

Q. Will the warranty be voided or cancelled if I do not operate or maintain my new SEA-DOO exactly as specified in the *Operator's Guide* ?

A. *No. The warranty on a new SEA-DOO cannot be "voided" or "cancelled". However, if a particular failure is caused by operation or maintenance other than as shown in the Operator's Guide, that failure may not be covered under warranty.*

Q. What responsibility does my dealer have under this warranty ?

1. *Completely set up every new SEA-DOO watercraft before sale ;*
2. *Explain the operation, maintenance and warranty requirements to your satisfaction at the time of sale. In addition, each SEA-DOO dealer is responsible for set-up, service and warranty repair work.*

Customer Service

If your SEA-DOO requires warranty service, you must take it to any authorized SEA-DOO dealer. Be sure to bring your warranty registration card or other valid proof of the original date of purchase. If a question or problem arises regarding warranty, first contact the owner of the SEA-DOO dealership.

Since mosts warranty matters are handled at the dealer level, this person is in the best position to help you. If you are still not satisfied and require additional assistance, please write to your area distributor, refer to LIST OF DISTRIBUTORS in this *Operator's Guide*.

REGISTRATION NUMBER LOCATION

All watercraft are required by federal law to be registered and legally numbered. Due to space availability for proper display of registration number, refer to the following illustration for location.

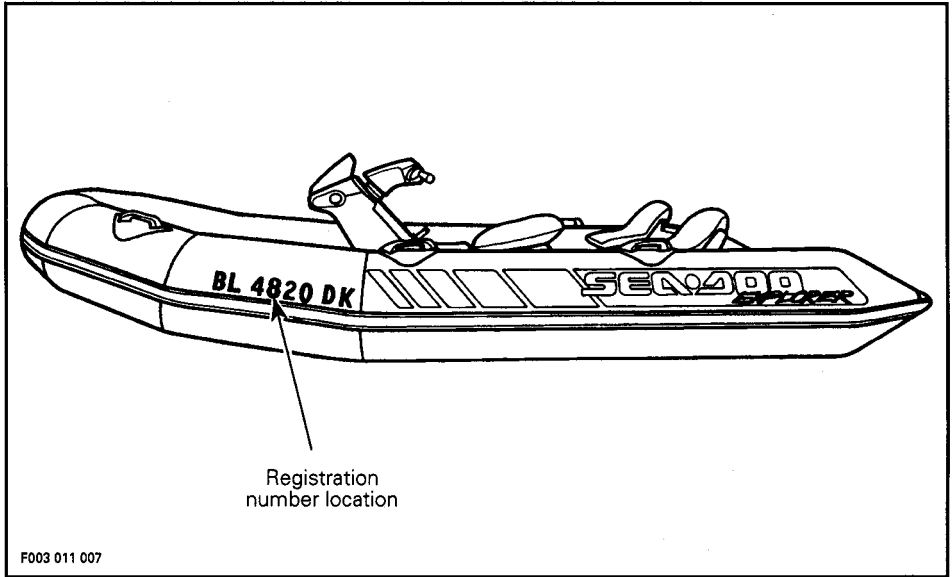

IDENTIFICATION OF COMPONENTS

Identification Numbers

The main components of the watercraft (engine, hull and tube) are identified by different serial numbers. It may sometimes become necessary to locate these numbers for warranty purposes or to trace the watercraft in the event of theft.

The Engine Identification Number (E.I.N.) is located on the upper side of the magneto housing.

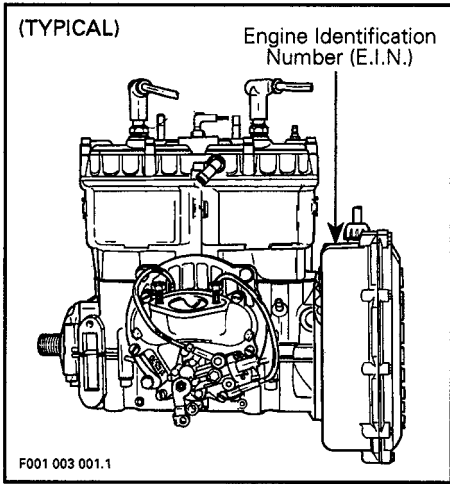

The Tube Identification Number (T.I.N.) is located on right hand plastic cone.

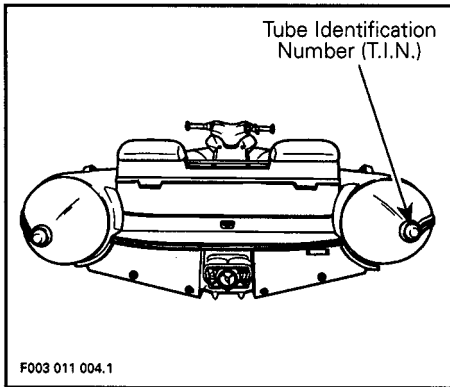

The Hull Identification Number (H.I.N.) is located at right hand rear side of hull.

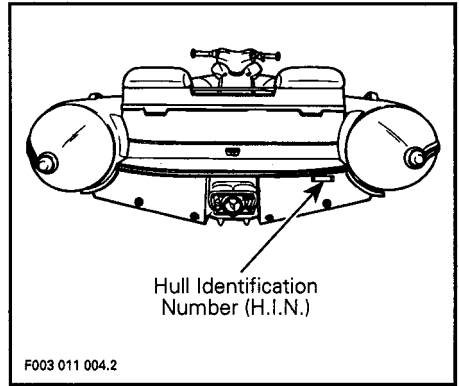

The watercraft model number can be found on U.S. Coast Guard approved label located on left hand side of front storage compartment cover.

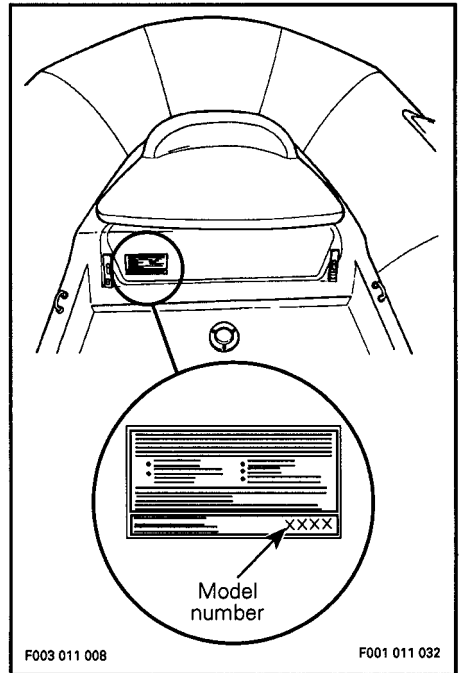

Controls and Components Location

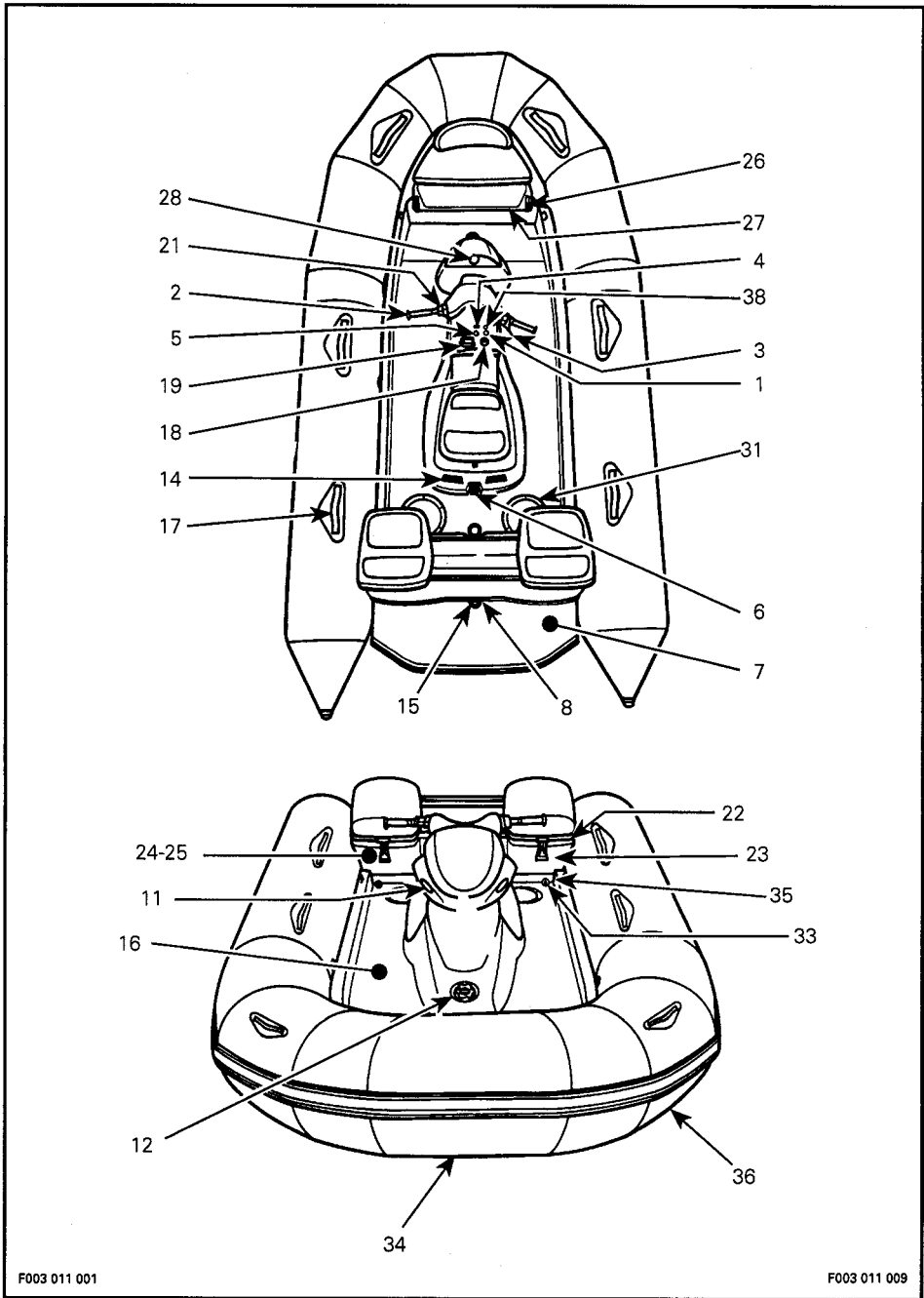

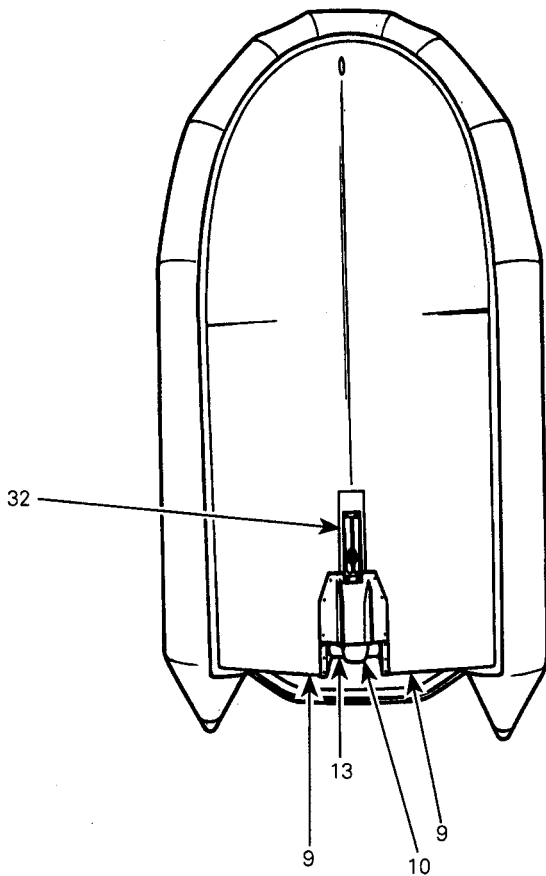
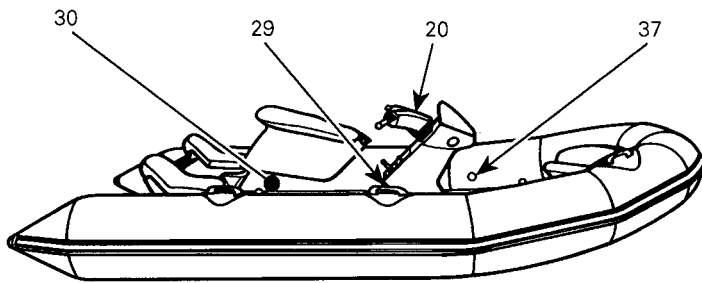

F003 011 011

F003 011 006

1) Safety Lanyard Switch

Pulling the safety lanyard from the switch stops the engine operation. Attach the safety lanyard to the operator's PFD and snap the cap to the switch to be able to start the engine.

▼ **CAUTION** : Always remove safety lanyard when leaving watercraft.

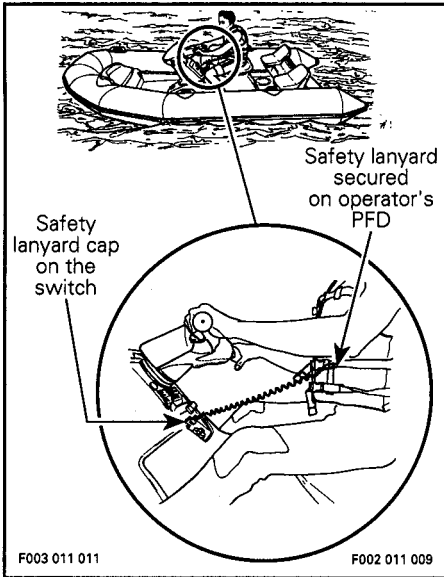

◆ **WARNING** : Should the engine be stopped, watercraft directional control is not available.

2) Handlebar

The handlebar controls the direction of the watercraft. Turning the handlebar to the right steers the watercraft to the right and inversely.

◆ **WARNING** : Check handlebar and corresponding steering nozzle operation before starting.

3) Throttle Lever

It controls the speed of the engine and therefore, the speed of the watercraft. When squeezed, watercraft accelerates. When fully released, engine automatically returns to idle speed and watercraft is gradually stopped by water drag.

◆ **WARNING** : Check throttle lever operation before starting the engine.

4) Choke Lever

The choke is provided to supply a richer fuel / air mixture when starting a cold engine. When the lever is completely pulled, the choke is fully applied. The use of the choke is not recommended with a warm engine.

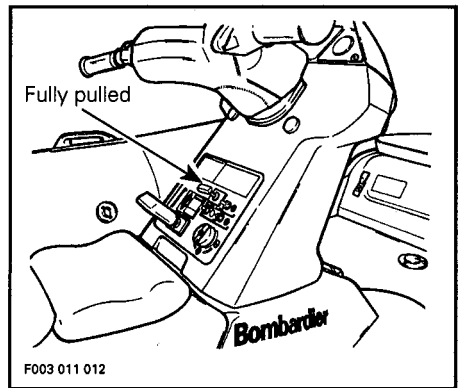

5) Starting Button

To start engine, depress and hold the button. Release immediately after engine is started.

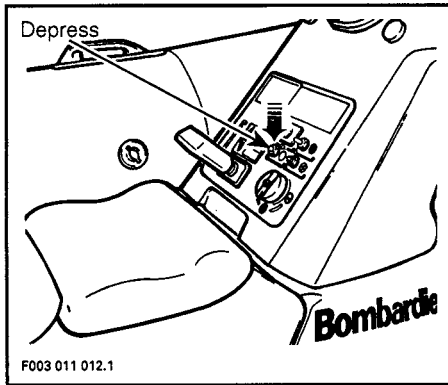

○ **NOTE** : Engine will not start if the safety lanyard is removed. Starting button is green to avoid any confusion with safety lanyard switch.

6) Engine Cover Opening

Removing the engine cover allows access to the engine compartment and to oil reservoir cap.

The engine cover latch is located at the rear end of cover.

To remove engine cover, pull the latch lever upward. With the operator seat integrated handle, lift and pull the engine cover rearward.

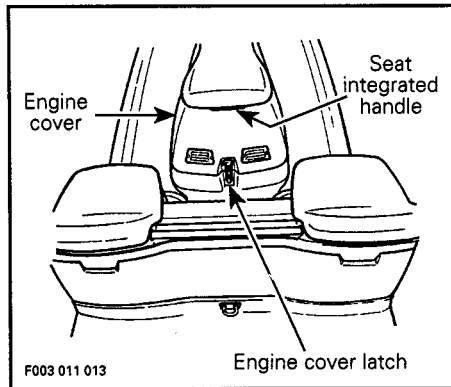

When reinstalling the engine cover, insert engine cover front tab into body hook and install rear latch lever.

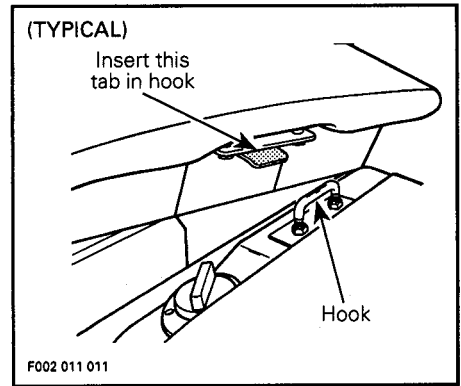

◆ **WARNING** : Periodically verify the seat hook upper nuts and lock nuts, tighten if needed. Make sure engine cover is securely latched.

7) Boarding Platform

Provide a large surface for easy boarding from rear of watercraft.

8) Cooling System Bleed Outlet

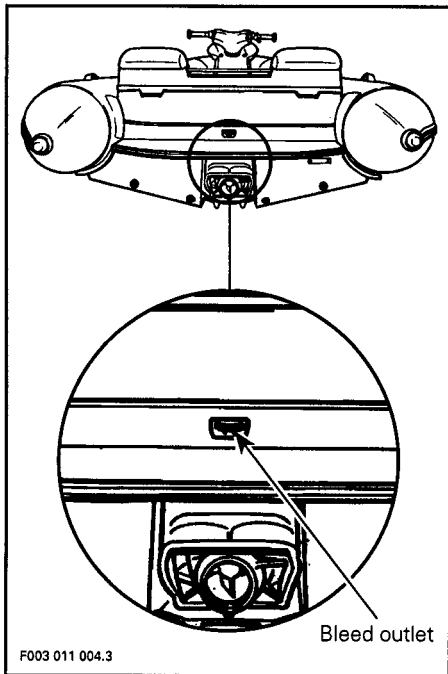

When engine is running, water must flow from this hole. This allows air in tuned pipe and in engine water jacket to escape. It also indicates that water is circulating in the cooling system.

▼ **CAUTION** : Should water not flow from this outlet a few seconds after engine starts, immediately stop engine and refer to **POST-OPERATION CARE** and look for cooling system flushing or refer to an authorized dealer for servicing.

9) Bilge Drain Plugs

Should water be found in the bilge, it can be easily drained by removing these plugs.

▼ **CAUTION** : Remove watercraft from water prior to removing the drain plugs.

Release the lever then remove plugs.

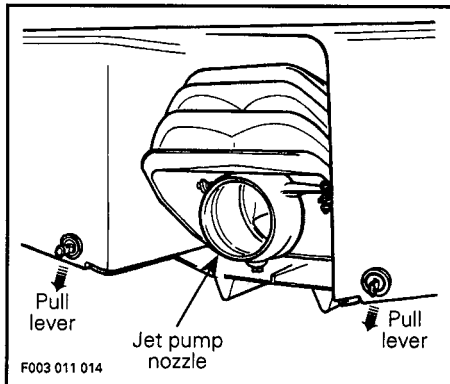

Tilt the watercraft slightly to the rear so that the water can completely flow out of the bilge.

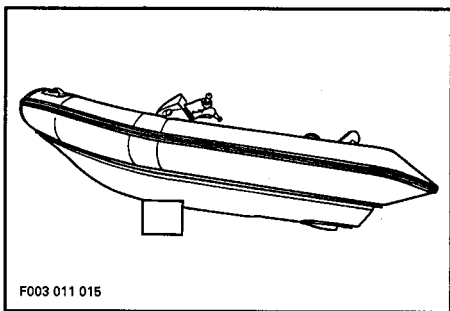

○ **NOTE** : Should the plug become loose in its hole, hold the plug then with the lever pulled, turn the lever clockwise to tighten (counter-clockwise to loosen). Adjust to have a watertight fit.

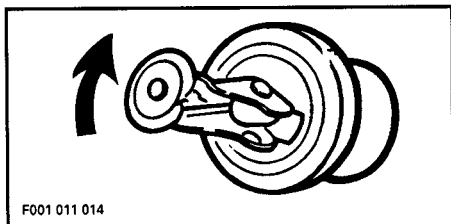

12) Fuel Tank Cap

Unscrew the cap counterclockwise to allow fuel tank filling. Fully tighten when finished.

◆ **WARNING :** Never use a lit match or open flame to check fuel level.

Reinstall bilge drain plugs and fully push the plug lever to locked position.

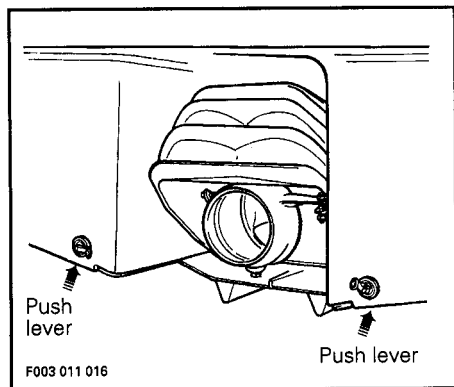

◆ **WARNING :** Always make sure bilge drain plugs are properly installed in the drain holes and levers are safely locked.

10) Jet Pump Nozzle

It is turned from side to side via rider input at the handlebar. This provides watercraft directional control when engine is running.

11) Air Intake Openings

This is where air enters to supply the engine and ventilate the engine compartment.

13) Reverse Gate

It moves from upward to downward position to get forward, neutral, reverse and inversely. These positions are obtained by sliding the reverse handle.

▼ **CAUTION :** Never use reverse gate as a supporting point to board the watercraft, it may damage reverse system components.

14) Rear Vent Grills

Allows air to get in or out depending on engine operation.

15) Stern Eyelet

Eyelet can be used for mooring, towing and as a tie-down point during transportation.

16) Floorboard

It is an antiskid surface. User's feet should rest on the floorboard when riding.

17) Grab Handles

Provides a handhold for the passengers.

▼ **CAUTION :** Never use the grab handles to pull anything or to lift the watercraft.

18) Fuel Tank Valve

A three-position rotating valve, OFF, ON, RESERVE :

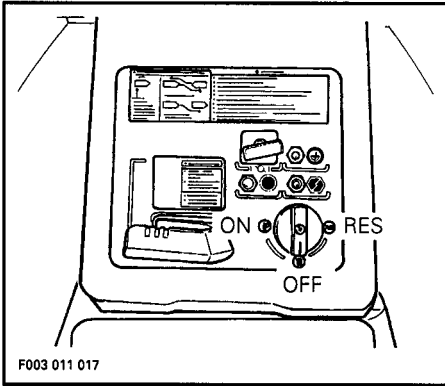

OFF : Stop fuel supply to carburetors.

▼ **CAUTION** : Turn valve to OFF position when watercraft is not operated.

ON : Allows fuel to flow to carburetors. This is the normal position for operation of watercraft.

RES : Use when the watercraft has run out of fuel in the ON position. Allow approximately 10 minutes operation at full throttle before running out of fuel.

◆ **WARNING** : Always refill the fuel tank at the first opportunity. After refueling, turn the fuel valve to the ON position for further operation.

19) Reverse Handle

When pushed in, the watercraft is in forward. To obtain neutral, unlock handle by turning it counterclockwise, then pull handle until neutral mark appears on rod. To engage reverse, repeat same procedure as for neutral, but pull handle until reverse mark appears on rod. Handle locks in forward and in neutral positions only.

◆ **WARNING** : Reverse handle should only be used when the engine is idling. Engaging the reverse gate at any other speed may damage reverse system components and possibly cause personal injuries. Ensure handle is pushed in and locked. Do not use as a grab handle.

20) Overheating Beeper

In the event the engine overheats, a beeper (continuous sound) will warn the operator. Stop the engine and refer to SPECIAL PROCEDURES.

21) Engine Stop Button

Located on left side of handlebar, this button is intended to stop engine when necessary. To use, fully release throttle lever then press the button.

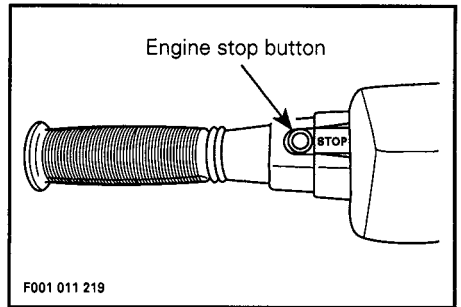

◆ **WARNING** : When the engine is stopped, watercraft directional control is not available.

22) Rear Storage Compartment Cover

To access storage compartment, pull the latch lever downward and gently lift cover. When completely lifted, the cover stays open with the help of a locking spring. To close cover, slightly push on spring. Secure cover latch after closing.

23) Rear Storage Compartment

A convenient watertight, compartment to carry the tool kit, *Operator's Guide* and personal articles. Ideal location for spare spark plugs, towrope, first aid kit, tube repair kit, tube foot pump, etc.

◆ **WARNING :** Never leave any heavy or breakable object in the storage compartment.

This area is the preferred location to store an approved extinguisher. The fire extinguisher holder is installed in the top right portion of the compartment. This holder contains tool kit, *Operator's Guide* and it has a compartment to carry personal articles. Fire extinguisher should not be left loose in the storage compartment.

24) Tool Kit

Contains tools needed to perform basic watercraft maintenance.

25) Operator's Guide

Should be kept in a waterproof bag and remain with the watercraft at all times even at the time of resale.

26) Front Storage Cover Latch

Pull the latch lever downward and lift in order to open the storage compartment cover. Always relatch.

27) Front Storage Compartment

A convenient watertight compartment to carry fishing seat, anchor, additional PFD, etc.

28) Fuel Gauge / Injection Oil Pilot Lamp

Located on windscreen, the analog gauge indicates the amount of fuel in the fuel tank and a light turns on when level is low in oil reservoir.

○ **NOTE :** With the safety lanyard disconnected, fuel gauge can be activated for approximately 30 seconds by depressing the starting button.

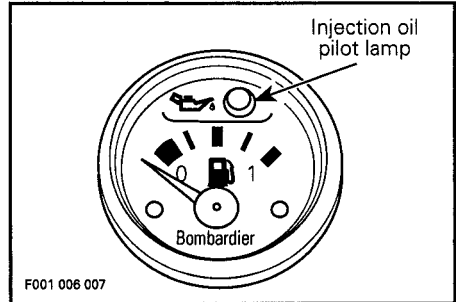

29) Oil Injection Reservoir Cap

○ **NOTE :** Engine cover has to be removed to access oil cap.

Verify oil level through oil reservoir. Unscrew the cap counterclockwise and add appropriate amount of oil.

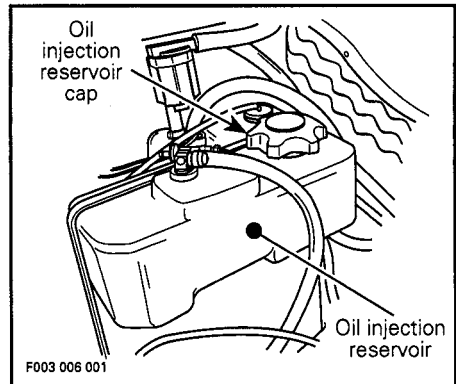

30) Engine Compartment

○ **NOTE :** Engine cover has to be removed to access engine compartment.

This is where the mechanical, electrical and fuel / oil systems are located.

◆ **WARNING :** When starting or operating the engine, do not touch any electrical part. Never leave any object, rag, tool, etc., in the engine compartment or in the bilge.

31) Access Covers

○ **NOTE :** Covers have to be removed to access bilge. This is where vacuum bailer pick-ups, cooling inlet and outlet, seal carrier and exhaust system are located.

32) Jet Pump Water Intake

The water is drawn up by the impeller through this opening. The impeller and the drive shaft are protected by a grate.

33) Deck Drain Holes

These two holes are located on each side of the deck at the rear. They provide drainage for rain, deck washing or water splashing through drain hoses.

34) Bow Eyelet

Eyelet can be used for mooring, towing and as a tie-down point during transportation.

35) Deck Eyelets

Eyelets should be used as material tie-down or for lifting the watercraft.

◆ **WARNING :** Ensure all loose equipment or material is securely tied down on board.

36) Inflatable Tube

Inflatable tube is composed of three airtight compartments, separated by partitions, inflated through recessed valves. It is equipped with six grab handles.

◆ **WARNING :** Never inflate tube more than 21 kPa (3 PSI).

37) Inflatable Tube Valves

Three valves are installed on the tube for each compartment. They are used to inflate or deflate tube as necessary. To get access to valve button, remove cap by unscrewing it a quarter of a turn counterclockwise.

38) Air Blower Switch

To start air blower, activate toggle switch. The air blower must be started four minutes prior starting the engine.

◆ **WARNING :** Blower must be turned off during watercraft operation.

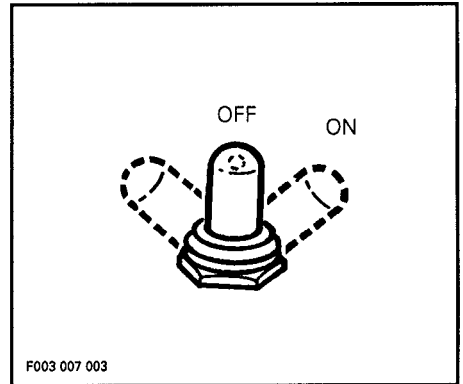

FUEL AND LUBRICATION

Recommended Fuel

Use regular unleaded gasoline with 87 octane (Ron + Mon / 2) specification.

○ **NOTE** : Look on service station pump sticker for octane specification. Do not mix oil with fuel except at engine break-in. Refer to BREAK-IN PERIOD. Always check injection oil reservoir level when refueling.

The use of good quality fuel is necessary. A well known fuel brand is highly recommended.

▼ **CAUTION** : The use of a poor quality fuel can result in watercraft performance deterioration and damage to fuel system and engine components. Refer to an authorized dealer immediately.

Pour fuel slowly so that air can escape from the reservoir and prevent fuel flowback.

Do not enter the spout too far in filler neck.

Fill fuel tank to bottom of filler neck. Do not overfill.

Fully tighten fuel tank cap and wipe off any fuel spillage.

◆ **WARNING** : Do not lean the watercraft to allow more fuel to fill the fuel tank. The tank design makes provision for fuel expansion of about 5%. If this area is filled, fuel will expand and may come out through fuel vent hose. Keep watercraft horizontal while fueling. Always stop the engine before refueling. Fuel is flammable and explosive under certain conditions. Always work in a well ventilated area. Do not smoke or allow open flames or sparks in the vicinity. Never experiment with other fuels or fuel ratios. Never use fuel containing alcohol, methanol or similar products including naphtha. The use of unrecommended fuel can result in watercraft performance deterioration and damage to critical parts in the fuel system and engine components. Never top off the fuel tank and leave watercraft in the sun. As temperature increases, fuel expands and might overflow. Always wipe off any fuel spillage from the watercraft.

Recommended Oil

Use only SEA-DOO INJECTION OIL which is available from authorized dealers. It is a blend of specially selected base oils and additives which provides outstanding lubrication, engine cleanliness and minimum spark plug fouling.

If SEA-DOO INJECTION OIL is not available, substitute with BOMBARDIER SNOWMOBILE INJECTION OIL (P/N 496 013 300 - 1L) or BOMBARDIER BLIZZARD OIL (P/N 496 013 500 - 500 mL).

○ **NOTE** : High quality low ash API TC injection oil for two-cycle engines can be used if SEA-DOO INJECTION OIL is not available.

▼ **CAUTION :** Never use four-cycle petroleum or synthetic motor oil and never mix these with outboard motor oil. Do not use NMMA TC-W, TC-W2 or TC-W3 outboard motor oils or other ashless type two-cycle oil. Avoid mixing different brands of API TC oil as resulting chemical reaction may cause severe engine damage.

Oil Injection System

This watercraft features an oil injection system which does not require manual fuel / oil mixing.

Oil level in reservoir should be maintained almost full. To check, remove seat to expose oil reservoir. Verify through oil reservoir. Unscrew cap to add oil as necessary.

Use a flexible funnel to pour oil into reservoir. Wipe off any oil spillage.

○ **NOTE :** Always carry a 500 mL of SEA-DOO INJECTION OIL.

▼ **CAUTION :** Always maintain a sufficient amount of injection oil in the oil reservoir. Check and refill every time you refuel. Do not overfill. If the engine runs out of oil, severe engine damage will occur. If the oil reservoir is found almost empty air can enter in the system and it must be bled. Immediately refer to an authorized dealer to have the oil injection system inspected.

BREAK-IN PERIOD

Engine

With Bombardier-Rotax® watercraft engines, a break-in period is required before operating the engine at full throttle. Engine manufacturer recommendation is about 10 operating hours.

During this period, maximum throttle should not exceed 3/4, however, brief full acceleration and speed variations contribute to a good break-in. Continued wide open throttle accelerations, prolonged cruising speeds and overloading the engine are detrimental during the break-in period.

To assure additional protection during the initial engine break-in, 765 mL (26 oz) of SEA-DOO INJECTION OIL should be added in the fuel tank for the first full fuel tank filling only.

▼ **CAUTION** : Remove and clean spark plugs after engine break-in.

10-Hour Inspection

It is highly recommended that after the first 10 hours of operation, the watercraft be checked by an authorized dealer. This inspection will also provide the opportunity to discuss the unanswered questions you may have encountered during the first hours of operation.

The 10-hour inspection is at the expense of the watercraft owner.

10-HOUR INSPECTION CHECK LIST	✓
Engine ignition timing if required	
Spark plug inspection, cleaning and adjustment	
Fuel system lines and fasteners / pressurization test	
Carburetor adjustment including throttle / choke cables if required	
Oil lines and filter	
Oil injection pump adjustment if required	
Engine support and engine rubber mounts	
Muffler, battery and reservoir fastening devices	
Exhaust system hose clamps torque	
Carburetor flange nuts and flame arrester bracket	
Steering stem arm torque	
Steering cable adjustment if required	
Reverse cable adjustment if required	
Hose condition and fasteners	
Bailer pick-ups, check for obstructions	
Safety lanyard switch / engine stop button operation, engine overheating beeper	
Electrical connections (starter, battery, etc.)	
Impeller shaft reservoir oil replacement	
Impeller condition, impeller / wear ring clearance	
PTO flywheel lubrication	
Seal carrier lubrication	
Water intake grill / hull condition	
Inspection of fasteners for tightness	
Inspect / clean engine drain tube	
Inflatable tube condition	

We recommend that this inspection chart be signed by an authorized dealer

Date of 10-hour inspection

Authorized dealer signature

DAILY PRE-OPERATION CHECKS

Some of the following items may not have been previously covered in this guide, however they will be described in the MAINTENANCE or SPECIAL PROCEDURES section. Please refer to these portions to have more detailed information.

Prior to your daily ride, verify the following :

◆ **WARNING :** Safety lanyard must always be removed from switch prior to verify any of the following.

ITEM	OPERATION	✓
Hull	Inspect.	
Jet pump water intake	Inspect / clean.	
Bilge	Drain. Ensure plugs are secured.	
Battery	Inspect tightness of cables and retaining straps.	
Fuel / oil reservoirs	Refill.	
Engine compartment	Verify fuel / oil system components.	
Fire extinguisher	Inspect condition / mounting.	
Steering / throttle systems	Check operation.	
Reverse system	Check operation.	
Inflatable tube	Visually inspect / verify air pressure.	
Safety lanyard / engine stop button	Check operation.	

Hull

Inspect hull for cracks or damage.

Jet Pump Water Intake

Remove weeds, shells, debris or anything else that could restrict the flow of water and damage cooling system or propulsion unit. Clean as necessary. If any obstruction can not be removed, refer to an authorized dealer for servicing.

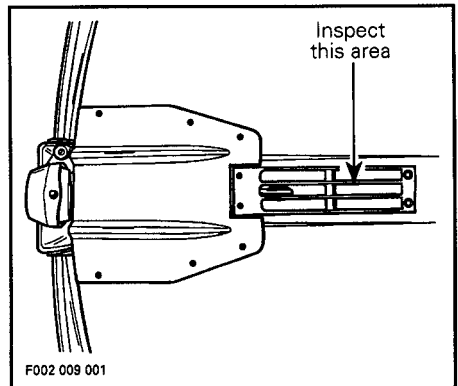

Inspect leading edges of the impeller, if they have nicks or bends performance will be greatly reduced.

Bilge

Should water be present in the bilge, have the watercraft tilted to the rear and remove drain plugs to completely empty the bilge.

◆ **WARNING** : Make sure to take the watercraft out of water prior to removing the drain plugs.

Reinstall bilge drain plugs and fully push the plug levers to lock.

Battery

◆ **WARNING** : Verify tightness of battery cables and retaining straps.

Fuel / Oil Reservoirs

With the watercraft horizontal, fill the fuel tank to specified level with fuel.

Check the oil level and refill reservoir as necessary.

Engine Compartment

Check condition of fuel/oil system components.

◆ **WARNING** : Should any leak or gasoline odors be present, do not start the engine or operate the watercraft. Immediately refer to an authorized dealer.

Fire Extinguisher

Make sure it is full, in good condition and well secured.

Steering / Throttle Systems

Assisted by another person, check steering operation for free movement. When the handlebar is horizontal, the jet pump nozzle should be in the straight ahead position. Ensure the jet pump nozzle pivots easily while handlebar is turned.

Check throttle lever several times for free and smooth operation. It must return to its initial position immediately after released.

Reverse System

Check reverse gate operation for free movement. With reverse handle push in and lock, the gate should be in upward position. Ensure the reverse gate moves easily while reverse handle is pulled out.

◆ **WARNING** : Verify the reverse gate locking operation before starting the engine.

Safety Lanyard / Engine Stop Button

Ensure that both switches operate properly. Start engine and stop it using each switch individually.

◆ **WARNING** : If engine does not shut-off when pushing engine stop button or by disconnecting the safety lanyard, stop the engine by applying the choke and turning fuel valve to OFF position. Do not operate the watercraft further, see an authorized dealer.

Inflatable Tube

Inspect tube for scratches and / or damage. Verify air pressure using valve adapter and pressure gauge. The air pressure should always be at 21 kPa (3 PSI).

○ **NOTE** : The valve adapter is part of the tube repair kit. A low pressure gauge can be used.

▼ **CAUTION** : An incorrect pressure will reduce the tube service life.

◆ **WARNING** : Never inflate tube more than 21 kPa (3 PSI). Inflating tube more than specified pressure may damage tube and cause personal injury. Never use high pressure to inflate tube.

Clothing

Always wear a Coast Guard approved PFD. It is also recommended that gloves, wet suit, deck shoes / booties and protective glasses be worn when operating in cooler temperatures.

Obstacles

Verify that the path ahead of the watercraft is clear of other craft or obstacles. Avoid riding close to swimmers. Check local boating laws for safe operation.

◆ **WARNING** : Only start the watercraft once all items have been checked and operate properly.

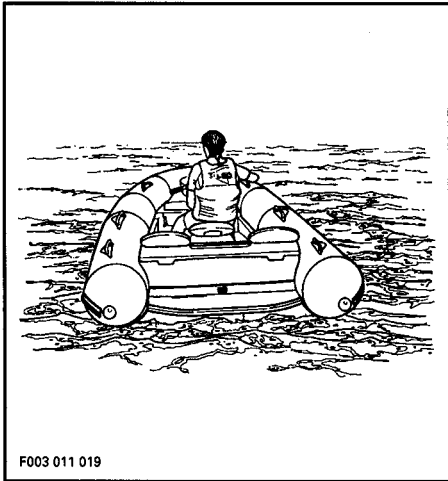

OPERATING INSTRUCTIONS

◆ **WARNING :** Always perform **DAILY PRE-OPERATION CHECKS** before operating the watercraft. Become thoroughly familiar with all controls and the function of each. Should any control or instruction be not fully understood, refer to an authorized dealer.

Principle of Operation

Propulsion

The engine is directly coupled to a drive shaft which, in turn, rotates an impeller. This impeller is accurately adjusted in a housing where the water is drawn up from underneath the watercraft. Then the water flows through the impeller to a venturi. The venturi accelerates the water and produces thrust to move the watercraft. Depressing the throttle lever increases engine speed and therefore watercraft speed.

The reverse handle is used for either driving the watercraft forward or backward. With handle push in, the watercraft is in forward position, with the handle fully pull out reverse position is obtained. The handle middle position is neutral. These three functions are produced by the mean of a gate, which is installed on jet pump venturi housing. This gate directs the water flow to get the proper function.

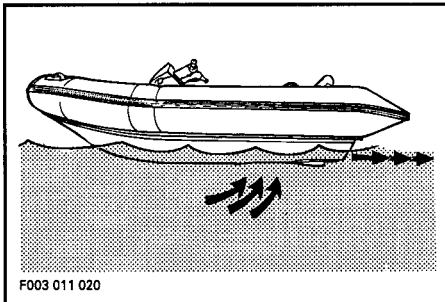

◆ **WARNING :** Whenever the engine is to be started, the operator should always be sitting on the watercraft with the reverse handle in neutral position. Reverse handle should only be used when the engine is **idling**. Engaging the reverse gate at any other speed may damage reverse system components and possibly cause personal injuries. Ensure handle is pushed in and locked.

Turning

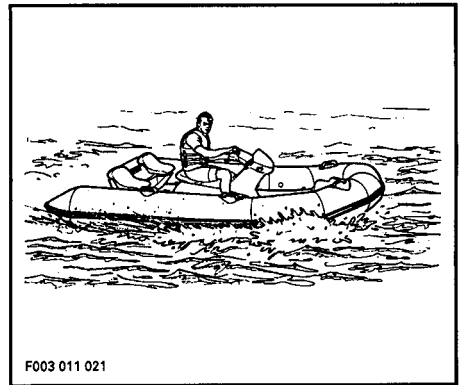

Turning the handlebar pivots the jet pump nozzle which controls the watercraft direction. Turning the handlebar to the right will turn the watercraft to the right and inversely. The throttle must be applied to turn the watercraft.

◆ **WARNING :** Directional control is lost when the throttle is closed. Throttle must be applied and handlebar turned to change the direction of the watercraft. Steering efficiency will differ depending on number of passengers, load and water condition.

The more the throttle is applied while turning the handlebar, the sharper the turn will be.

The watercraft behaves differently with passengers and requires greater skill. The passengers should always grip the grab handles. Reduce speed and avoid sharp turns. Avoid choppy water conditions when carrying passengers.

Boarding from a Dock or in Shallow Water

As with any craft, getting aboard should be done carefully.

When boarding from a dock, slowly place one foot on the watercraft deck nearest the dock and then move the other foot over inflatable tube. Never use the inflatable tube as a boarding support. Push the watercraft away from the dock.

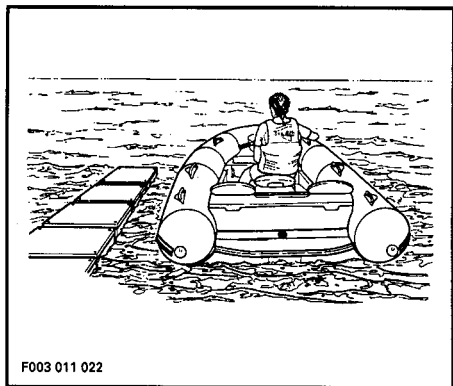

CAUTION : The engine should be started with at least 90 cm (3 ft) of water below the hull.

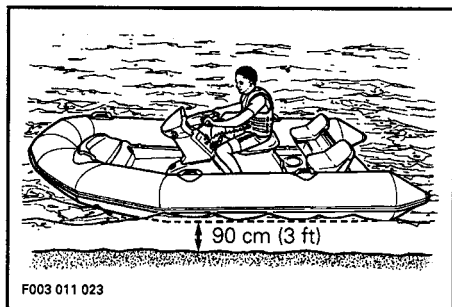

In shallow water, board the watercraft either from the side or the rear.

WARNING : An inexperienced operator should practice how to get aboard close to the shore to simulate deep water boarding. Refer to Boarding in Deep Water in this section.

Starting the Engine

Before unloading the watercraft from the trailer, it can be started for about 10 seconds to verify proper operation. Remove stern (rear) strap before starting the engine.

WARNING : Do not touch electrical parts or jet pump area when engine is running.

Always activate air blower switch four minutes before starting the engine. The air blower will ventilate the bilge.

WARNING : Blower must be turned off during watercraft operation.

Attach the safety lanyard to the operator's PFD and snap the cap to the switch.

Cold Engine

Operator and passengers should be sitting on the watercraft seats prior to starting the engine.

Turn the fuel valve to ON position.

Firmly grip handlebar with your right hand and place both feet on the floorboard. Shut off air blower switch.

Fully pull the choke lever and depress the starting button.

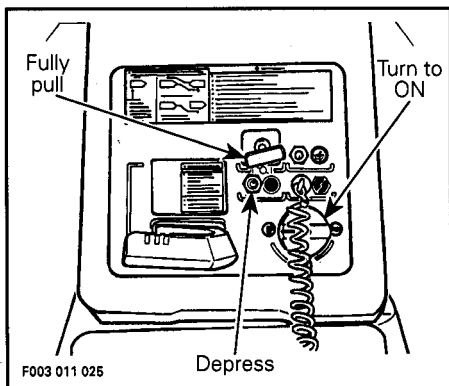

Immediately after engine is started, release starting button and release choke lever half way.

○ **NOTE** : Do not depress the throttle lever while starting a cold engine.

▼ **CAUTION** : To avoid starter motor overheating, the cranking period should not exceed 5-10 seconds and a rest period should be observed between cranking cycles to let the starter cool down and its mechanism disengage. Never depress the starting button when the engine is running.

A few seconds after, completely push the choke lever and if necessary, slightly apply throttle to keep engine running.

Slowly accelerate to reach deeper water. Do not apply full throttle until the engine is warm.

▼ **CAUTION** : In shallow water, shells, sand, pebbles or other objects could be drawn up by the jet pump and damage impeller, components or clog the cooling system.

Warm Engine

The same procedure as a cold engine applies, except the choke does not need to be applied and throttle lever has to be slightly depressed.

Boarding in Deep Water

◆ **WARNING** : Inexperienced riders should practice how to get aboard close to shore first before venturing into deep water.

Operator Alone

Swim to the rear of the watercraft.

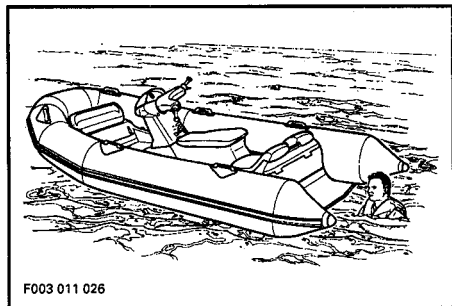

Grip the grab bar and pull yourself upward until your knee can reach the platform.

▼ **CAUTION** : Never use reverse gate as a supporting point to board the watercraft, it may damage reverse system components.

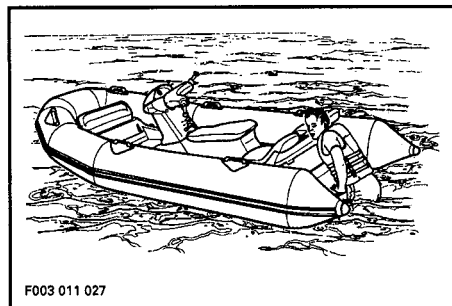

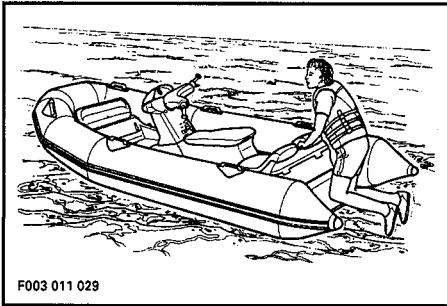
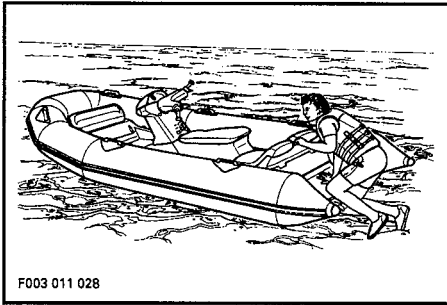

Always activate air blower switch four minutes before starting the engine.

Attach the safety lanyard to the operator's PFD and snap the cap to the switch.

Start the engine.

Operator with Passengers

The operator climbs on the watercraft the same way as explained previously.

The passenger then climbs on the watercraft while the operator may help him in climbing aboard.

◆ **WARNING :** It is not recommended to climb aboard from tube area using grab handle.

Always activate air blower switch four minutes before starting the engine.

Attach the safety lanyard cap to the switch.

◆ **WARNING :** Do not start engine until the passengers are properly seated.

Rough Water Operation

Do not ride in rough water and / or adverse weather conditions.

◆ **WARNING :** Riding the watercraft in these conditions could cause loss of control, injury or death to the operator and / or passengers.

Always assist the rider(s) of a capsized boat then attempt to retrieve vessel using a towrope.

It is not recommended to operate the watercraft within or around the surf-line.

◆ **WARNING :** Wave jumping is a dangerous and possibly illegal practice. Do not jump waves or boat wakes.

Crossing Waves

Reduce speed and cross the wave head on to assist steering.

Always be prepared to steer and balance as necessary.

◆ **WARNING :** When crossing waves, operator and passengers should brace themselves by posting.

Stopping / Docking

The watercraft is slowed by water drag. The stopping distance will vary depending on weight, water surface condition, presence and direction of wind and current.

The operator should familiarize himself with the stopping distance under different conditions.

Release the throttle at a sufficient distance before the expected landing area, water resistance slows down the watercraft.

Reduce speed when approaching a dock then shut off the engine just before coming alongside.

◆ **WARNING** : No directional control is available when the throttle is closed or engine is shut off. Never use the reverse system for stopping the watercraft.

Beaching

▼ **CAUTION** : It is not recommended to run the watercraft to the beach.

Proceed the same way as for docking except for the following :

Come slowly to the beach and shut off the engine when reaching about 90 cm (3 ft) of water under the hull.

▼ **CAUTION** : Avoid docking or beaching where sharp objects are present. Tube perforation may occur.

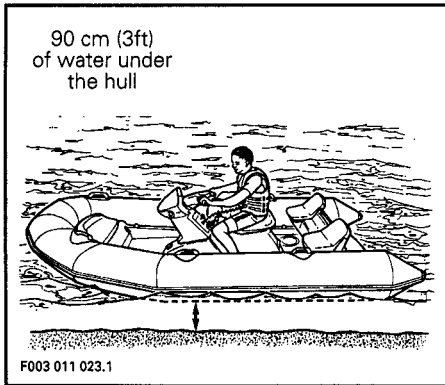

▼ **CAUTION** : In shallow water, shells, sand, pebbles or other objects could be drawn up by the jet pump and damage impeller, components or clog or jam cooling system.

Get off watercraft and pull it on the beach.

As necessary, cooling system should be flushed before restarting, to remove sand or shell accumulation which may clog the water passages.

Shutting Off the Engine

To keep watercraft directional control, the engine should be running until the watercraft is stopped assuming at least 90 cm (3 ft) of water is present underneath the hull.

To shut off the engine, completely release throttle lever and press the engine stop button.

Remove safety lanyard from watercraft.

◆ **WARNING** : Should the engine be shut off, watercraft directional control is not available. Never leave the safety lanyard on an unattended watercraft.

POST-OPERATION CARE

General Care

Should any water be present in the hull, remove the drain plugs and tilt the watercraft to the rear in order to allow water to flow out.

Wipe up any remaining liquid in the engine compartment (bilge, engine, battery, etc.) with clean dry rags (this is particularly important in salt water use).

Remove the watercraft from the water every day to prevent marine organisms growth.

Leave the engine cover partially opened. This will avoid engine compartment condensation and possible corrosion.

○ **NOTE** : When the watercraft is stored with engine cover partially opened and without a tarpaulin, remove the drain plugs in order to avoid water build up in the bilge during rainfall.

Additional Care for Foul Water or Salt Water

When the watercraft is operated in foul water and particularly in salt water, additional care must be taken to protect the watercraft and its components. Rinse bilge area with fresh water.

▼ **CAUTION** : Failure to perform proper care such as : watercraft rinsing, cooling system flushing and anticorrosion treatment, when watercraft is used in salt water, will result in damage to the watercraft and its components. Never leave the watercraft stored in direct sunlight. UV radiation will decrease tube life and dull finishes.

Cooling System Flushing and Engine Internal Lubrication

Flushing the cooling system with fresh water is essential to neutralize corroding effects of salt or other chemical products present in water. It will help to clean up sand, salt, shells or other particles in water jackets (engine, exhaust manifold, tuned pipe) and / or hoses.

Engine lubrication and flushing should be performed when the watercraft is not expected to be used further the same day or when the watercraft is stored for any extended time.

An optional coupler hose can be installed on the watercraft to ease flushing.

Proceed as follows :

◆ **WARNING** : Perform this operation in a well ventilated area.

1. Clean jet pump by spraying water in its inlet and outlet and then SEA-DOO LUBE.
2. Remove seat to allow access of cooling system.
3. Remove dust cap from fitting spigot and attach coupler hose. Make sure coupler hose is properly locked to fitting spigot.

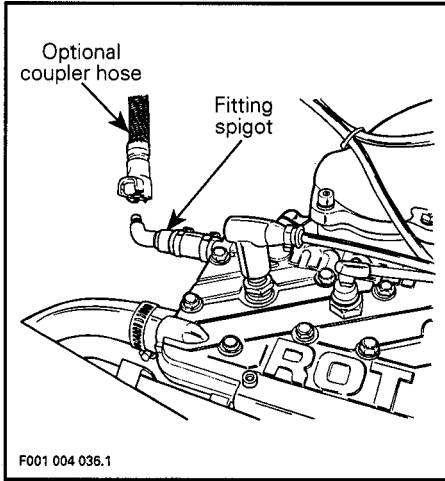

Attach other end of coupler hose to a garden hose. Do not open water tap yet.

○ **NOTE** : To allow a more efficient flushing on watercraft, install a hose pincher on water outlet hose. This prevents water from exiting through exhaust socket. Remove hose pincher after flushing operation.

4. Start the engine then immediately open the water tap.

◆ **WARNING** : Do not touch any electrical parts or jet pump area when engine is running.

▼ **CAUTION** : Never flush a hot engine. Always start the engine before opening the water tap. Otherwise, water will back flow through the tuned pipe into the engine and may cause damage to internal parts. Open water tap immediately after engine is started to prevent overheating.

5. Run the engine about three minutes at a fast idle around 3500 RPM.

▼ **CAUTION** : Never run engine longer than five minutes. Drive line seal has no cooling when watercraft is out of water.

6. Remove plug from air intake silencer cover.

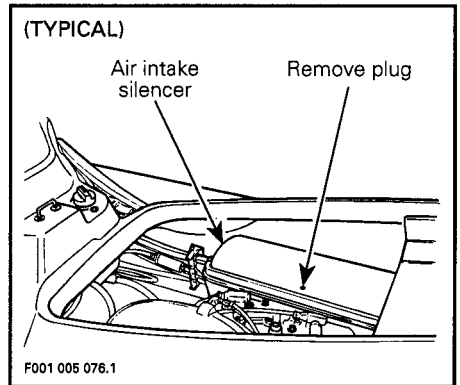

7. Spray SEA-DOO LUBE through air intake silencer keeping engine at fast idle.

This should be done for at least one minute. After approximately half a minute, close fuel valve to run engine out of fuel while lubricating.

▼ **CAUTION** : When engine begins to run irregularly because of fuel starvation, immediately stop water flow before engine dies. Severe engine damage could result if not done in this order.

8. Close the water tap then stop the engine.

9. Unlock and remove coupler hose. Reinstall dust cap over tee fitting spigot.

10. Wipe up any residual water from the engine.

11. Remove spark plug cables and connect them on the grounding device.

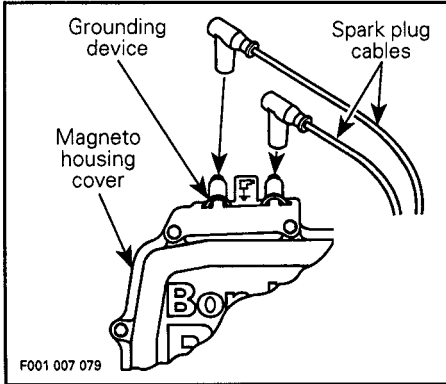

Remove both spark plugs and spray SEA-DOO LUBE into each cylinder.

Crank the engine a few turns to distribute the oil on cylinder wall.

12. Apply anti-seize lubricant on spark plug threads then reinstall them.
13. Reinstall plug on air intake silencer cover.

Anticorrosion Treatment

To prevent corrosion, spray a corrosion inhibitor (salt water resistant) such as SEA-DOO LUBE or equivalent over metallic components in engine compartment.

○ **NOTE :** Engine fogging should be done with SEA-DOO LUBE whenever the watercraft is to be stored for few days or a long period.

Apply a dielectric grease (salt water resistant) on battery posts and cable connectors.

▼ **CAUTION :** Never leave rags or tools in the engine compartment or in the bilge.

SPECIAL PROCEDURES

Engine Overheat

If the engine overheating beeper sounds, stop engine immediately.

Perform the **Jet Pump Water Intake and Impeller Cleaning** procedure in this section.

Flush cooling system, refer to POST OPERATION CARE.

If engine still overheats, refer to an authorized dealer for servicing.

Jet Pump Water Intake and Impeller Cleaning

Weeds, shells or debris can get caught on the intake grill, drive shaft and / or impeller. A clogged water intake may cause troubles such as :

- 1- **Cavitation** : Engine speed is high but watercraft moves slowly due to reduced jet thrust ; jet pump components may be damaged.
- 2- **Overheating** : Since the jet pump operation controls the flow of water to cool the engine, a clogged intake will cause the engine to overheat and damage engine internal components.

The clogged area can be cleaned as follows :

In-water cleaning : Rock the watercraft several times while repeatedly pressing starter button for short period without starting engine. Most of the time, this will results in letting the weeds falling from the intake area. Start engine and make sure water flows out from bleed outlet and watercraft operates properly.

On-beach cleaning : Place a cardboard or a carpet beside the watercraft to prevent scratching when turning the watercraft for cleaning. Deflate left and front tube compartments.

◆ **WARNING** : Always remove safety lanyard cap from switch to prevent accidental engine starting before cleaning the jet pump area.

Rotate the watercraft **counterclockwise** (seen from rear) to its left side for cleaning. Rotating watercraft counterclockwise eliminate the possibility of residual water in the tuned pipe to enter the engine and cause engine damage.

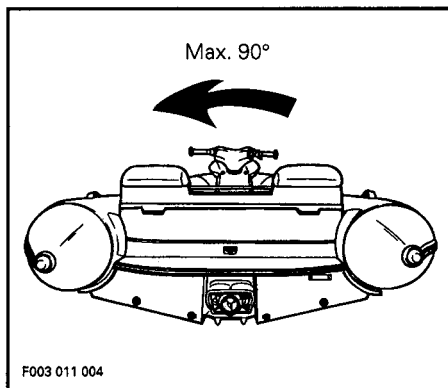

Clean the water intake area. If the system is still clogged, refer to an authorized dealer for servicing.

▼ **CAUTION** : Inspect water intake grill for damage. Refer to an authorized dealer for repair as necessary.

If the system is operating properly, inflate tube to 21 kPa (3 PSI) before using the watercraft.

▼ **CAUTION** : Avoid watercraft operation in weed areas. If unavoidable, vary watercraft speed. Weeds tend to entangle more at steady speed and at slow speed.

Capsized Watercraft

The watercraft is designed so that it should not turn over easily, due to its longer and larger dimensions and its inflated tubes. If it turns over, it will remain capsized. To return the watercraft upright proceed as follows :

- Deflate the right tube (seen from rear)
- Rotate watercraft clockwise (seen from rear) by pushing on the right side
- Handhold the side of water intake hole and use your weight to complete the watercraft rotation.

Submerged Watercraft

If the watercraft is submerged and engine is water-flooded, it is strongly recommended that the watercraft be serviced by an authorized dealer immediately.

In the event the engine cannot be serviced within a few hours. Remove engine crankcase drain plugs located underneath oil injection pump.

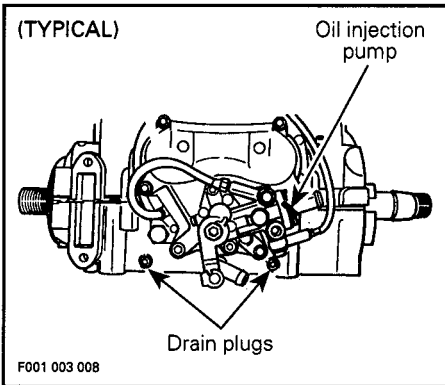

Remove spark plug cables and connect them on the grounding device.

◆ **WARNING** : Never crank engine with spark plugs removed unless spark plug cables are connected to the grounding device.

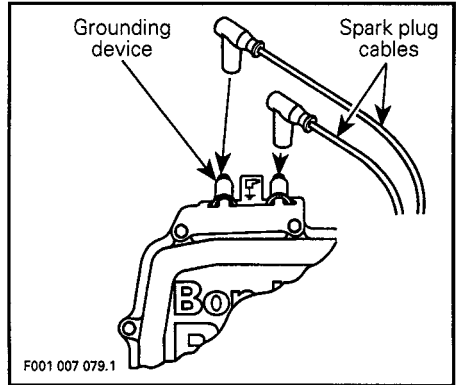

Remove spark plugs and dry them with a clean and dry cloth.

Cover spark plug holes with a rag.

Crank engine to allow water to escape from spark plug and drain plug holes.

Spray SEA-DOO LUBE into spark plug holes.

Crank engine again.

Reinstall spark plugs and drain plugs.

▼ **CAUTION** : Crankcase drain plugs should have pipe sealant applied to threads before installing.

Towing the Watercraft

In the event the watercraft becomes inoperative, tie a tow rope to the bow (front) eyelet and have the watercraft towed to the shore at moderate speed.

Low-Charge Battery Condition

See your dealer to have it charged or replaced.

◆ **WARNING** : Do not charge or boost the battery in the watercraft. Connecting cables could produce a spark and possibly cause an explosion if fuel or electrolyte vapors are present.

MAINTENANCE

◆ **WARNING :** Only perform procedures as detailed in this guide. It is recommended that the assistance of an authorized dealer be periodically obtained on other components / systems not covered in this guide. Unless otherwise specified, engine must not be running and the safety lanyard must be removed for all maintenance procedures.

○ **NOTE :** Servicing period is given in hours. On an average, three hours is equivalent to using one tank of gasoline.

Lubrication

PTO Flywheel and Seal Carrier

Use SEA-DOO synthetic grease and lubricate every 10 hours. Proceed as follows :

Remove engine cover to access engine compartment.

Remove the wing nuts, washers and pull out PTO flywheel guard.

◆ **WARNING :** Always remove safety lanyard cap from its receptacle to prevent accidental engine starting before removing the PTO flywheel guard.

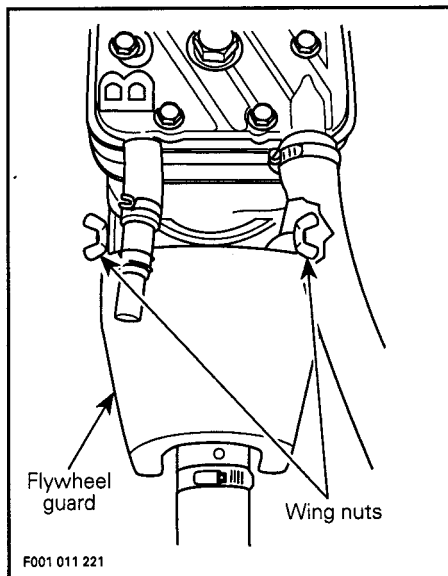

Using a grease gun, carefully lubricate PTO flywheel at grease fitting until drive shaft boot is just beginning to expand.

▼ **CAUTION :** Immediately stop lubricating as soon as boot begins to expand to prevent boot damage or slipping.

Lubricate seal carrier at grease fitting until grease is just coming out.

▼ **CAUTION :** Never leave any clothing, tool or other objects near PTO flywheel and seal carrier. As soon as grease comes out the seal immediately stop lubricating to prevent seal damage and overheating.

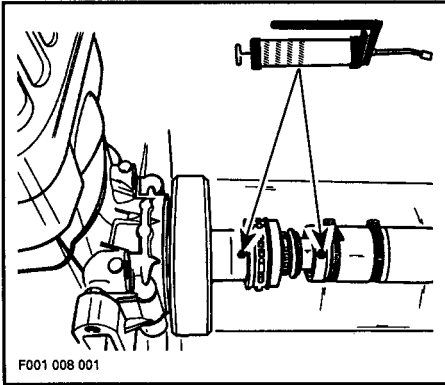

Secure PTO flywheel guard.

Anticorrosion Protection

Throttle / Choke Cables

Lubricate the throttle and choke cables with SEA-DOO LUBE every 25 hours and every 10 hours in salt water use.

Electrical Connections

As necessary, apply anticorrosion product such as a dielectric grease on battery posts and all exposed cable connectors.

Additional Lubrication

SEA-DOO LUBE will help to prevent corrosion and keep proper operation of moving mechanisms.

Lubrication of the following items should be performed every 50 hours in fresh water use but every 10 hours in salt water use.

Choke Lever

Fully pull choke lever and lubricate the metallic portion.

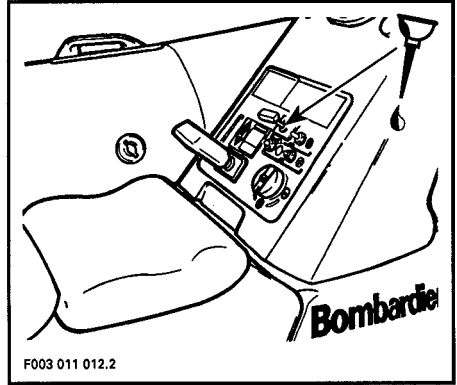

Engine Cover Attachment, Tab and Hook

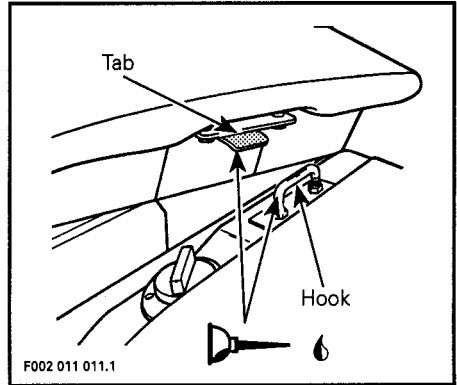

Carburetors and Oil Injection Pump

Lubricate springs, shafts and exposed portion of cables.

○ NOTE: Grease carburetor linkage at both ends with synthetic grease.

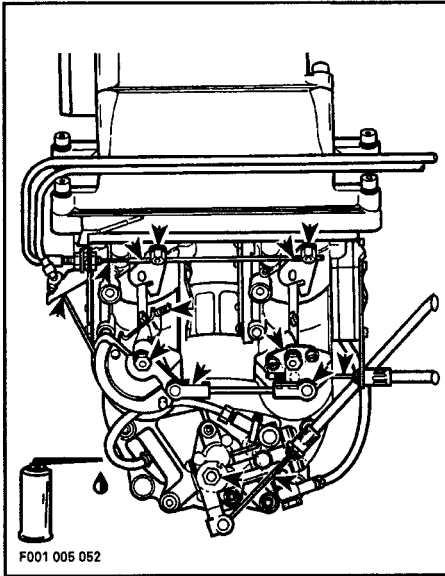

Reverse Handle System

Lubricate support plate sliding area of sliding block.

Periodic Inspection

Routine maintenance is necessary for all mechanized products. A periodic inspection contributes to the products life span.

The following maintenance chart gives guidelines for regular watercraft servicing schedule to be performed by you and / or by an authorized dealer. The schedule can be adjusted according to operating conditions and use.

IMPORTANT : Schedule for watercraft rental operations or higher number of hour use, will require greater frequency of inspection and maintenance.

Periodic Inspection Chart

DESCRIPTION	FREQUENCY				To be performed by
	every 10 hours	every 25 hours	every 50 hours	every 100 hours or seasonally	
Lubrication / corrosion protection	①		✓		OPERATOR
Engine ignition timing				✓	DEALER
Spark plug replacement			✓		DEALER
Throttle / choke cables, inspection / lubrication	①	✓			OPERATOR
Flame arrester element, inspection			✓		DEALER
Carburetor adjustment including choke / throttle cable adjustments and linkage				✓	DEALER
Oil injection pump adjustment				✓	DEALER
Fuel filter and oil filter inspection		✓			DEALER
Oil filter and fuel filter replacement				✓	DEALER
Engine head screws, retorque				✓	DEALER
Steering system			✓		DEALER
Reverse system / reverse cable adjustment				✓	DEALER
Fastener tightening (Flame arrester mount screws, carburetor mount nuts, engine mount screws, exhaust system, etc.)			✓		DEALER
Muffler, battery and reservoir fastening devices			✓		OPERATOR
Fuel / oil line, check-valve and hose inspection, fuel system pressurization			✓		DEALER
Inspect / clean engine drain tube	①	✓			DEALER
Bilge system / deck drain holes, inspection			✓		OPERATOR
Battery condition			✓		DEALER
Battery and starter cables		✓			DEALER
Engine overheating beeper / electrical connections			✓		DEALER
Impeller shaft reservoir oil level / oil condition		✓		Replace	DEALER
Impeller condition and impeller / wear ring clearance		②	✓		DEALER
Drive shaft boot and spline condition (both ends)		②	✓		DEALER
PTO flywheel lubrication	✓				OPERATOR
Seal carrier lubrication	✓				OPERATOR
Water intake grill condition		②	✓		DEALER
Hull condition				✓	DEALER
Cooling system flushing ③		✓			OPERATOR
Inflatable tube condition		✓		④	DEALER
Zinc anode			✓		OPERATOR
Air blower inspection			✓		DEALER

○ NOTE : Some items are included in the DAILY PRE-OPERATION CHECKS and are not necessarily repeated in this chart.

① Every 10 hours in salt water use.

② These items have to be initially checked after 25 hours. Thereafter, servicing to be made as specified in this chart.

③ Daily flushing in salt water or foul water use.

④ Inflatable tube should be removed and cleaned. Also verify tube attachment condition.

Throttle and Choke Cable Inspection

Throttle Cable

Depress and release the throttle lever several times. It must operate smoothly and return to its initial position without any hesitation. Refer to an authorized dealer if necessary.

◆ **WARNING** : If throttle lever does not automatically return, do not operate watercraft and see your dealer.

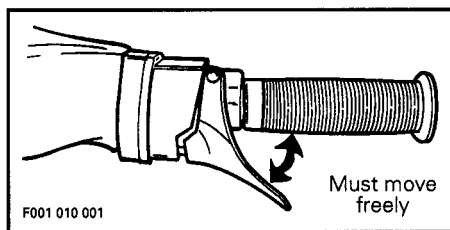

Choke Cable Inspection

Ensure it operates smoothly and without any hesitation from fully open to fully close. When the choke lever is fully pulled, choke must be fully applied. Refer to an authorized dealer if necessary.

Carburetor Adjustment

Carburetor adjustment is very important to allow good engine operation and therefore watercraft performance. Carburetor adjustment require technical knowledge and experience to have the correct mixture supplied to the engine. These critical adjustment must be performed by an authorized dealer once a year or more often if necessary.

▼ **CAUTION** : Serious engine damage can occur with improper carburetor adjustment.

Fuel and Oil Filters

These filters should be replaced by an authorized dealer annually. Fuel system pressurization should be conducted at the same time.

▼ **CAUTION** : An obstructed oil filter will cause oil starvation resulting in serious engine damage.

Steering / Jet Pump Nozzle Adjustment

When the handlebar is aimed in straight ahead position, the jet pump nozzle should be in the same direction to allow the watercraft running in straight line.

Refer to an authorized dealer if an adjustment is necessary.

◆ **WARNING** : Ensure the handlebar / jet pump nozzle operate freely from side to side and are not stressing the steering cable and / or bracket.

Steering system wear should be inspected every 50 hours by an authorized dealer.

Reverse Gate Adjustment

When reverse handle is pushed in and locked, reverse gate should be in an upward position. With the handle half way out and locked, reverse gate should be in middle position. When handle is fully pulled out reverse gate should be in downward position. Refer to an authorized dealer if adjustment is necessary.

◆ **WARNING** : Ensure the reverse handle / reverse gate operate freely and are not stressing the reverse cable. Always make sure reverse handle locks in forward.

Vacuum Bailer Pick-Ups and Deck Drain Holes

Vacuum Bailer Pick-Ups

Remove access covers. Bailers are located each side of the drive shaft tunnel.

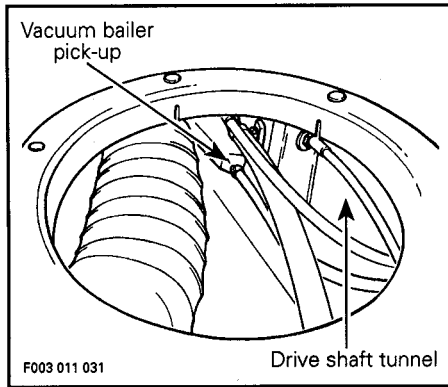

This watercraft features a vacuum activated syphon. Two pick-ups use a low pressure area in the jet pump to syphon the water out of the bilge.

Inspect each pick-up screen for obstructions, clean as necessary.

Deck Drain Holes

Check for possible obstructions at drain outlets each side of hull rear section.

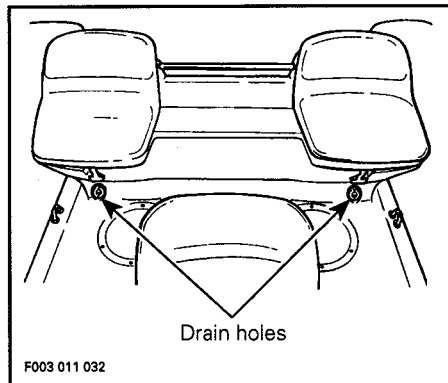

Fuses

Electrical system is protected with two fuses. One fuse protects the charging circuit, the second fuse protects the accessories and controls. If starter does not operate and battery is regularly discharged, check fuse condition. The fuse caps are in the electrical box located on port side (left) and hold spare fuses.

To access fuse caps unclip electrical box from its seat.

Bring it over magneto housing and remove cover.

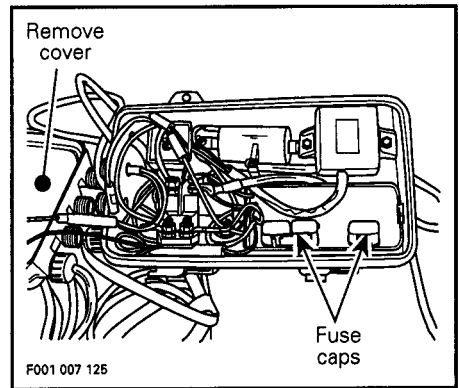

Replace the fuse by one of the same rating. Make sure to properly close the fuse cap.

▼ **CAUTION** : Do not use a higher rated fuse as this can cause severe damage. Refer to SPECIFICATIONS section for recommended fuse rating.

Wires in electrical box cover must hang freely. Do not pack wires in cover.

◆ **WARNING** : If any water is found in the electrical box, immediately refer to an authorized dealer before operating the watercraft.

Properly close electrical box cover making sure its seal is well positioned.

Air Blower

Verify air blower for proper operation and security inlet tube.

◆ **WARNING** : If air blower does not operate properly, immediately refer to an authorized dealer before operating the watercraft.

Zinc Anode

Zinc anode is located on ride shoe. Verify anode in order to replace it as necessary.

Tube Inflation

Proceed as follows :

Remove valve cap of a rear section by unscrewing it a quarter of a turn counterclockwise.

Check that the center plunger is in the upright position.

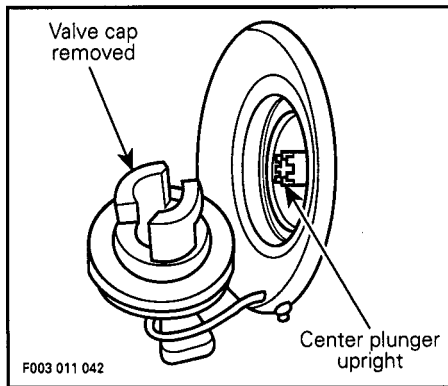

Insert foot pump hose end with proper adapter into the valve opening.

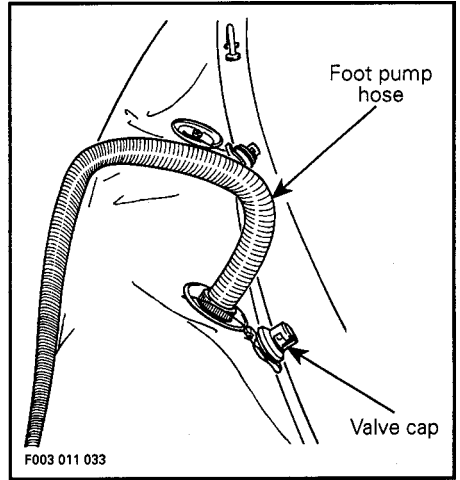

Inflate with one foot by pressing down on the foot pump.

▼ **CAUTION** : Always inflate rear sections FIRST. Inflate front section LAST.

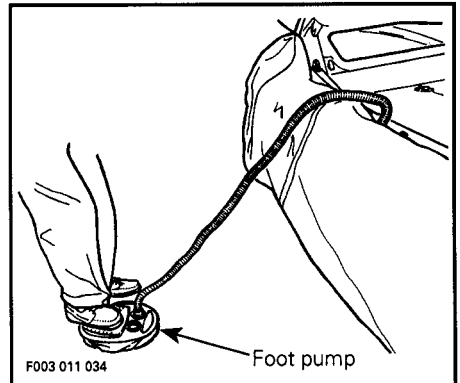

○ **NOTE** : Inflation is sufficient when you can no longer put air into the tube section using one foot.

When inflation is finished, remove foot pump hose end from valve.

Verify pressure using valve adapter (included in tube repair kit) and a low pressure gauge (70 kPa (10 PSI)).

○ **NOTE** : Seat valve adapter as quickly as possible onto valve opening and firmly maintain in position to avoid air loss.

Pressure must be set at 21 kPa (3 PSI). If pressure is too high, reduce it by slightly pushing the center plunger.

◆ **WARNING** : Never inflate tube more than 21 kPa (3 PSI). Inflating tube more than specified pressure may damage tube and possibly cause personal injury. Never use high pressure to inflate tube.

When pressure is set, screw valve cap.

○ **NOTE** : It is very important to seal the valve with this cap in order to increase air tightness and to keep out unwanted dirt and water.

Proceed with the same procedure for the remaining tube sections.

Order of Inflation

The tubes must be inflated to the recommended pressure at all times.

○ **NOTE** : When you can't depress the tube with the pressure of your finger, you have reached approximate working pressure.

Air pressure in tube sections should be rechecked while the watercraft is afloat ; adjust if necessary, as the temperature of the water may be different from that of the air, which could result in changes in air pressure.

○ **NOTE** : Exterior air temperature affects tube air pressure; always adjust.

Tube Deflation

Remove valve cap of any tube sections by unscrewing it a quarter of a turn counterclockwise.

Push and twist the center plunger in either direction to lock it into the open position.

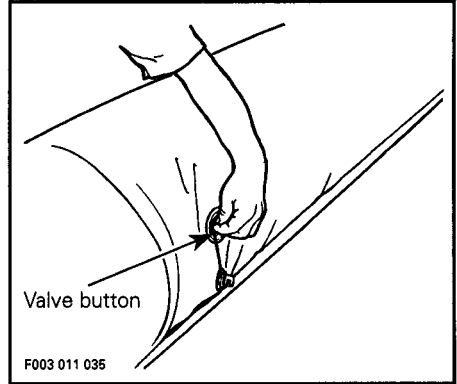

The tube section will now automatically deflate.

Reinstall valve cap.

Proceed with the same procedure for the remaining tube sections.

Minor Repairs

Tear Repairs of Less than 5 cm (2 in)

For best results, repairs should be performed in temperatures of 18° to 25°C (64° to 77°F). Avoid carrying out repairs in direct sunlight, rain or in conditions of high humidity.

○ **NOTE** : For any major repair, refer to an authorized dealer.

Deflate completely tube section to be repaired.

Cut a patch about 3 cm (1 in) larger than the tear in every direction. Always round corners

Using only a pencil, trace the position of the patch on the tube.

▼ **CAUTION** : Do not use pen or felt-tip pen as ink will permanently mark tube.

Sand thoroughly the area of the tube with a 80 grit sandpaper.

○ **NOTE** : Protect tube surface in vicinity with masking tape.

○ NOTE : Supplied materials included in repair kit don't need to be sanded.

Remove masking tape.

Clean the patch and tube areas with a solvent such as methyl ethyl ketone, toluene or acetone. Allow solvent to completely evaporate.

Apply a thin layer of adhesive (included in repair kit or use Bostik 2402-A with hardener 2402-B) to the patch and the tube. Allow to dry so that adhesive is dry to the touch.

○ NOTE : Mix Bostik glue and hardener as per instruction on its package.

Apply a second thin layer of adhesive on both parts.

Allow the second coat to dry until tacky to the touch ; then, apply the patch.

Smooth out the patch with a spoon-shaped tool working from the center to the outside to remove all excess glue and air bubbles.

Allow 24 hours to dry before inflating.

Clean any excess of glue.

General Inspection and Care

Inspection

Check engine compartment for any damage and fuel / oil injection systems for leaks. Also check battery vent tube for electrolyte leaks. Ensure all hose clamps are properly secured and no hose is cracked, kinked or presenting any other damage.

◆ WARNING : If any gasoline leak is found, do not start the engine. Have the watercraft serviced by an authorized dealer. Failure to correct a leak could lead to an explosion.

Inspect muffler, battery and reservoir fastening devices. Check electrical connections for corrosion and tightness.

Care

Twice a year, the bilge should be cleaned with hot water and detergent or bilge cleaner to remove any possible fuel / oil / electrolyte deposits and mildew.

Occasionally, wash the body with hot water and soap (only use mild detergent). Remove any marine organisms from engine and /or hull. Apply non-abrasive wax such as silicon wax.

▼ CAUTION : Never clean apparent fiberglass and plastic parts with strong detergent, degreasing agent, paint thinner, acetone, etc.

When the watercraft is operated in foul water and particularly in salt water, tube must be rinsed frequently with fresh water.

Occasionally, wash the tube with warm water and soap (only use mild detergent).

Stubborn stains and scuff marks may be removed using methyl ethyl ketone, toluene or acetone.

▼ CAUTION : Never clean decals with strong detergent, methyl ethyl ketone, toluene or acetone. Limit application of these solvents on tube joints to avoid glue dilution.

TRANSPORTATION, STORAGE AND PRE-SEASON PREPARATION

Transportation

◆ **WARNING** : Always turn the fuel valve to OFF position when transporting the watercraft.

Tie the watercraft to both bow and stern (front / rear) eyelets so that it is firmly retained on the trailer. Use additional cables if necessary.

▼ **CAUTION** : Do not route ropes or tie-downs over the seats or tubes as they could produce permanent damage. Wrap ropes or tie-downs with rags or similar protectors where they can touch the watercraft body.

Ensure engine and storage covers are properly latched.

A SEA-DOO cover should protect the watercraft, particularly before driving on dirt roads.

Observe trailering safety precautions.

Storage

It is recommended that the watercraft be serviced by an authorized dealer for storage but the following operations can be performed by you with a minimum of tools.

▼ **CAUTION** : Do not run the engine during the storage period.

Engine Draining

Check engine drain tube running from exhaust manifold fitting to exhaust outlet socket. Make sure there is no sand or other particles in it and that it is not obstructed so that water can leave the engine. Clean tube and fitting (on exhaust outlet) as necessary.

▼ **CAUTION** : Water in engine drain tube must be free to flow out, otherwise water could be trapped in engine. Should water freeze in engine, severe damage will occur. Check engine drain tube for obstructions.

(TYPICAL)

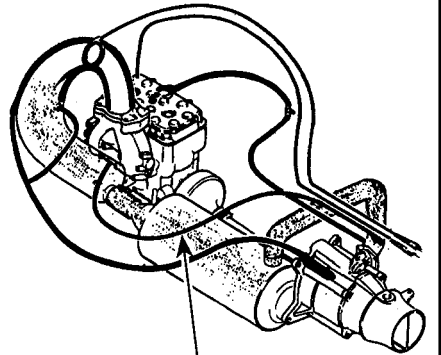

F003 004 001.3

Watercraft Rinsing

Thoroughly rinse the watercraft hull, bilge, engine compartment, with fresh water.

Propulsion System

Lubricant in impeller shaft reservoir should be drained and reservoir cleaned. Refilled with 65 mL (2.2 oz) of SEA-DOO synthetic polyolester oil 75W90 GL5 type C gear lube. Refer to an authorized dealer for this operation.

▼ **CAUTION** : Use only SEA-DOO jet pump oil or equivalent synthetic gear oil, otherwise component service life could be reduced. Do not mix oil brands or types.

Lubricate PTO flywheel at grease fitting with synthetic grease.

▼ **CAUTION** : Do not lubricate excessively. Immediately stop when a slight movement is noticed on rubber boot.

Lubricate seal carrier at grease fitting until grease is just coming out.

▼ **CAUTION** : As soon as grease comes out the seal, immediately stop lubricating to prevent seal damage and overheating.

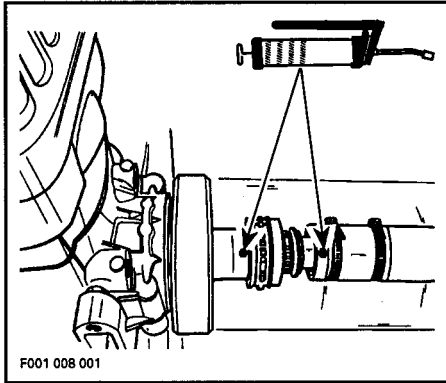

Fuel System

SEA-DOO fuel stabilizer (or equivalent), can be added in fuel tank to prevent fuel deterioration and carburetor gumming. Follow manufacturer's instructions for proper use.

▼ **CAUTION** : Fuel stabilizer should be added prior engine lubrication to ensure carburetor protection against varnish deposit.

◆ **WARNING** : Fuel is flammable and explosive under certain conditions. Always work in a well ventilated area. Do not smoke or allow open flames or sparks in the vicinity. Always wipe off any fuel spillage from the watercraft. Always turn the fuel valve to OFF position when storing the watercraft.

Cooling System Flushing and Engine Internal Lubrication

Refer to procedure discussed in "Post-Operation Care".

Battery

Contact your authorized dealer or refer to the appropriate *Shop Manual* for proper storage procedure.

Anticorrosion Treatment

Wipe off any residual water in the engine compartment.

Spray SEA-DOO LUBE over metallic components in engine compartment.

Additional Recommended Protection

Cooling system may be filled with an equal part of water and antifreeze solution.

▼ **CAUTION** : Always use ethylene glycol antifreeze containing corrosion inhibitors specifically recommended for aluminum engines.

○ **NOTE** : The engine will not have to run during this operation.

Three hoses have to be disconnected to allow air to escape and antifreeze solution to completely fill cooling system water jackets.

Install a hose pincher on water injection hose.

Disconnect water inlet hose, drain hose and water outlet hose.

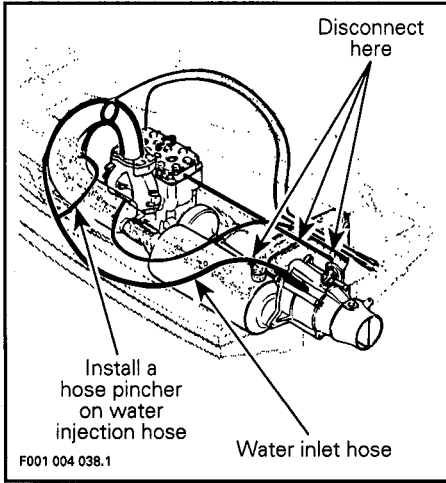

Raise all hoses above the highest point of tuned pipe and temporarily tie them together.

Insert a funnel into inlet hose going to the water inlet socket at tuned pipe. Pour about two liters (1/2 gal) of anti-freeze solution through the funnel.

Tie up all hoses higher than tuned pipe.

○ **NOTE** : If hoses are not attached higher than tuned pipe, coolant will drain out.

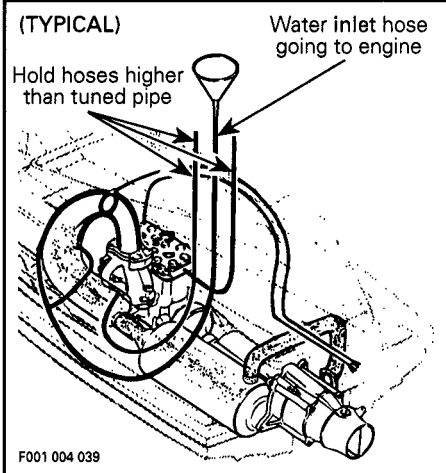

The following steps should be performed to provide the watercraft enhanced protection.

Remove muffler and drain out as much water as possible. Reinstall muffler.

OR : Disconnect one hose from muffler and pour some antifreeze liquid inside muffler. Reconnect hose.

Lubricate the throttle cable with SEA-DOO LUBE.

Clean the bilge with hot water and detergent or with bilge cleaner. Rinse thoroughly. Lift front end of watercraft to completely drain bilge. If any repairs are needed to body or to the hull contact your dealer. For paint touch up to mechanical parts use Bombardier spray paint. For small gelcoat repairs, a Bombardier repair kit is available. See **Accessories and Service Products** section. Replace damaged labels / decals.

○ **NOTE** : Bilge cleaning should be done prior to anticorrosion treatment.

Wash the body with soap and water solution (only use mild detergent). Rinse thoroughly with fresh water. Remove marine organisms from the hull. Apply a nonabrasive wax such as silicon wax.

▼ **CAUTION** : Never clean apparent fiberglass and plastic parts with strong detergent, degreasing agent, paint thinner, acetone, etc.

If the watercraft is to be stored outside, cover it with an opaque tarpaulin to prevent sun rays and grime from affecting the plastic components, watercraft finish as well as preventing dust accumulation.

For storage period, tube should be cleaned and dried.

If possible, store the watercraft with the tube sections 90% inflated. If this is not possible, fold the tube into the hull and tie it loosely into this position.

▼ **CAUTION** : Never leave the watercraft stored in direct sunlight. UV radiation will decrease tube life and dull finish. The watercraft must never be left in water for storage. Keep away from rodents.

The engine cover should be partially left opened during storage. This will avoid engine compartment condensation and possible corrosion.

○ **NOTE** : If the watercraft is stored outside with engine cover partially opened and without a tarpaulin, remove the rear drain plugs in order to avoid water build up in the bilge during rainfall. Tilt the watercraft to the rear so that water can flow out of floorboard.

Pre-Season Preparation

Use the following chart.

Since technical skills and special tools are required, some operations should be performed by an authorized dealer.

◆ **WARNING** : Observe **WARNINGS** and **CAUTIONS** mentioned throughout this guide which are pertinent to the item being checked. When component conditions seem less than satisfactory, replace with genuine **BOMBARDIER** parts or approved equivalents.

Pre-Season Preparation Chart

 **NOTE :** It is highly recommended that the dealer perform at the same time the annual safety inspection in addition to the pre-season preparation.

OPERATIONS	To be performed by
Lubrication / corrosion protection	OPERATOR
Battery condition / charging and reinstallation	DEALER
Battery, starter connections and routing ②	DEALER
Spark plug replacement ①	OPERATOR
Impeller shaft reservoir oil inspection	DEALER
Propulsion system inspection	DEALER
Oil filter replacement	DEALER
Oil injection tank filling	OPERATOR
Flame arrester cleaning / inspection ②	DEALER
Fuel filter replacement	DEALER
Fuel line condition ②	DEALER
Filler neck, fuel tank and fuel cap condition ②	DEALER
Check valves, fasteners, fuel system pressurization ②	DEALER
Throttle ② / choke cable inspection / adjustment	DEALER
Oil injection pump adjustment and bleeding	DEALER
Engine ignition timing	DEALER
Carburetor adjustment	DEALER
Steering system adjustment / inspection ②	DEALER
Reverse cable adjustment	DEALER
Inspection of deck drain holes / bilge lines / bailer pick-ups	DEALER
Inspection of cooling system inlet / outlet hoses ②, engine overheating beeper	DEALER
Fire extinguisher condition / mounting ②	OPERATOR
Tube and tube attachment condition	DEALER

① Before installing new spark plugs, it is suggested to burn the excess SEA-DOO LUBE by starting the engine using the old spark plugs.

② Safety item covered in the annual safety inspection.

 **WARNING :** Only perform this operation in a well ventilated area. Coupler hose must be installed or watercraft must be in water to cool engine. Running the engine without cooling water will damage exhaust hose interior and may damage engine.

TROUBLESHOOTING

The following chart is provided to help in diagnosing the probable source of simple troubles. You may be able to solve many of these problems rather quickly, but others may require the skills of a mechanical technician. In such a case, consult an authorized dealer for servicing.

ENGINE WILL NOT START

OTHER OBSERVATION	POSSIBLE CAUSE	REMEDY
Engine does not turn over	<ul style="list-style-type: none"> • Safety lanyard removed • Burnt fuse • Discharged battery • Battery connections, corroded or loose • Water flooded engine 	Install cap over switch. Check wiring then replace fuse. Refer to an authorized dealer. Refer to an authorized dealer. Refer to Submerged Watercraft in SPECIAL PROCEDURES.
Engine slowly turns	<ul style="list-style-type: none"> • Discharged or weak battery 	Refer to an authorized dealer.
Engine turns over	<ul style="list-style-type: none"> • Fuel tank empty or water-contaminated • Fuel filter clogged or water-contaminated • Fuel flooded engine : <ul style="list-style-type: none"> – Fouled / defective spark plugs – Misuse of choke 	Refill. Syphon and fill with fresh fuel. Clean, check fuel tank for water. Replace. Use only with cold engine. Replace spark plugs.

ENGINE MISFIRES, RUNS IRREGULARLY

OTHER OBSERVATION	POSSIBLE CAUSE	REMEDY
Weak spark	<ul style="list-style-type: none"> • Fouled / defective / worn spark plugs • Faulty rev limiter • Too much oil supplied to engine 	Replace. Refer to an authorized dealer. Improper oil pump adjustment, refer to an authorized dealer.
Lean fuel mixture	<ul style="list-style-type: none"> • Fuel : Level too low, stale or water-contaminated • Fuel filter, clogged or water-contaminated 	Syphon and / or refill. Refer to an authorized dealer.
Rich fuel mixture (high fuel consumption)	<ul style="list-style-type: none"> • Flame arrester dirty / clogged • Partially closed choke 	Clean or replace. Refer to an authorized dealer.

ENGINE OVERHEATS

OTHER OBSERVATION	POSSIBLE CAUSE	REMEDY
Overheating beeper sounds	<ul style="list-style-type: none"> • Clogged jet pump water intake • Incorrect type of fuel or oil • Clogged coolant system 	Clean. Syphon and refill. Flush cooling system with coupler hose.

ENGINE CONTINUALLY BACKFIRES

OTHER OBSERVATION	POSSIBLE CAUSE	REMEDY
	<ul style="list-style-type: none">• Faulty rev limiter	Refer to an authorized dealer.
Weak spark	<ul style="list-style-type: none">• Fouled / defective / worn spark plugs	Replace.
Overheated engine	<ul style="list-style-type: none">• See ENGINE OVERHEATS	

ENGINE PINGING OR KNOCKING

OTHER OBSERVATION	POSSIBLE CAUSE	REMEDY
	<ul style="list-style-type: none">• Poor quality gasoline / low octane• Spark plug heat range too high	Use well known quality and recommended gasoline. Use recommended spark plugs.

ENGINE LACKS ACCELERATION OR POWER

OTHER OBSERVATION	POSSIBLE CAUSE	REMEDY
	<ul style="list-style-type: none">• Weak spark / incorrect fuel mixture• Water in fuel or injection oil	Refer to ENGINE MISFIRES... Syphon and replace.
Overheated engine	<ul style="list-style-type: none">• See ENGINE OVERHEATS	

WATERCRAFT CAN NOT REACH TOP SPEED

OTHER OBSERVATION	POSSIBLE CAUSE	REMEDY
	<ul style="list-style-type: none">• Jet pump water intake clogged• Damaged impeller	Clean. Replace. Refer to an authorized dealer.

ABNOMAL NOISE FROM PROPULSION SYSTEM

OTHER OBSERVATION	POSSIBLE CAUSE	REMEDY
	<ul style="list-style-type: none">• Weeds or debris jammed around impeller	Clean and check for damage.
	<ul style="list-style-type: none">• Damaged impeller shaft or drive shaft	Refer to an authorized dealer.

SPECIFICATIONS

ENGINE		EXPLORER (5821)
Engine type		Bombardier-Rotax 657, 2-stroke
Induction type		Rotary valve
Exhaust system		Water cooled / water injected
Lubrication	Type	Oil injection
	Oil type	SEA-DOO INJECTION OIL
Number of cylinders		2
Displacement		650 cm ³ (39.66 in ³)
Rev limiter setting		7000 RPM ± 100
COOLING		
Type		Water cooled, total loss type. Direct flow from propulsion unit.
Overheating beeper, switch on @		96-99°C (205-210°F)
ELECTRICAL		
Magneto generator output		160 W @ 6000 RPM
Ignition system type		Capacitor discharge ignition (breakerless)
Spark plug	Make and type	NGK, BR8ES
	Gap	0.5 - 0.6 mm (.020 - .024 in)
Starting system		Electric starter
Battery		12 V, 19 A
Starting system fuse		5 A
Charging system fuse		15 A
CARBURETION		
Fuel type		Regular unleaded gasoline
Carburetor		Diaphragm type, quantity : 2

PROPULSION		EXPLORER (5821)	
Propulsion system		Bombardier Formula Jet Pump	
Jet pump type		Axial flow, single stage	
Transmission		Direct drive	
Impeller shaft reservoir, oil type		SEA-DOO synthetic polyolester oil 75W90 gear lube	
Pivoting angle of direction (nozzle)		~26°	
Minimum required water level for jet pump		90 cm	(3 ft)
DIMENSIONS			
Number of passengers ①		1 operator and 4 passengers	
Overall length		396 cm	(155.9 in)
Overall width		206 cm	(81.1 in)
Overall height		132 cm	(52 in)
Weight (dry)		322 kg	(710 lb)
Load limit (passengers + luggage)		474 kg	(1045 lb)
Hull Material		Composite	(Fiberglass)
Tube material		Neoprene, hypalon, polyester reinforced	
CAPACITIES			
Fuel tank		48 L	(12.6 U.S. gal)
Impeller shaft reservoir	Capacity	65 mL	(2.2 U.S. oz)
	Oil level	Up to plug	
Injection oil reservoir		4.5 L	(153 U.S. fl. oz)

① Refer to load limits.

BOMBARDIER INC. reserves the right to make changes in design and specifications and / or to make additions to, or improvements in its products without imposing any obligation upon itself to install them on its products previously manufactured.

SI* METRIC INFORMATION GUIDE

BASE UNITS			
DESCRIPTION	UNIT	SYMBOL	
length	meter	m	
mass	kilogram	kg	
force	newton	N	
liquid	liter	L	
temperature	Celsius	°C	
pressure	kilopascal	kPa	
torque	newton-meter	N•m	
land velocity	kilometer per hour	km / h	
navigation velocity	knot	kn	

PREFIXES			
PREFIX	SYMBOL	MEANING	VALUE
kilo	k	one thousand	1000
centi	c	one hundredth of	0.01
milli	m	one thousandth of	0.001
micro	μ	one millionth of	0.000001

CONVERSION FACTORS			
TO CONVERT	TO [ⓐ]	MULTIPLY BY	
in	mm	25.4	
in	cm	2.54	
in ²	cm ²	6.45	
in ³	cm ³	16.39	
ft	m	0.3	
oz	g	28.35	
lb	kg	0.45	
lbf	N	4.4	
lbf•in	N•m	0.11	
lbf•ft	N•m	1.36	
lbf•ft	lbf•in	12	
PSI	kPa	6.89	
imp. oz	U.S. oz	0.96	
imp. oz	mL	28.41	
imp. gal	U.S. gal	1.2	
imp. gal	L	4.55	
U.S. oz	mL	29.57	
U.S. gal	L	3.79	
knot	MPH	1.15	
MPH	km / h	1.61	
Fahrenheit	Celsius	(°F - 32) ÷ 1.8	
Celsius	Fahrenheit	(°C × 1.8) + 32	
hp	kW	.75	

* The international system of units abbreviates SI in all languages.

① To obtain the reverse sequence, divide by the given factor. To convert "millimeters" to "inches", divide by 25.4.

○ **NOTE** : Conversion factors are rounded off to two decimals for easier use.

ACCESSORIES AND SERVICE PRODUCTS

These accessories and other fine Sea-Doo products are available at your dealer.

ACCESSORIES

Coupler Hose
P / N 295 500 099



F001 004 035

Hose Pincher
P / N 295 000 076

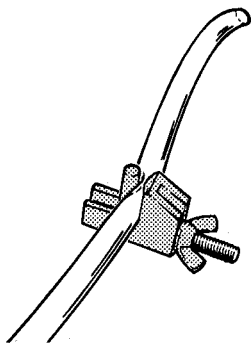

A001 001 091

Impeller
See your authorized Sea-Doo dealer for appropriate choice of impeller

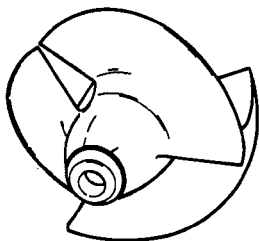

F001 001 022

ACCESSORIES

Extinguisher
P / N 298 770 000 (US)
P / N 298 777 000 (CAN)



F001 001 023

Sea-Doo Cover
EXPLORER P / N 298 350 009

Bimini Top
P / N 295 500 163

Lighting Kit
P / N 295 500 147

ACCESSORIES

First Aid Kit

P / N 298 296 001

Survival Kit

P / N 298 295 040

Tie-Down (purple)

Up to 1.50 m (5 ft) long

P / N 298 752 040

Up to 3.60 m (12 ft) long with
ratchet

P / N 298 753 040

Fishing Seat Sleeve

P / N 204 000 101

Lift Kit

P / N 298 780 090 (Nickel-plated)

P / N 298 790 040 (Stainless steel)

PRODUCTS

Synthetic Grease

P / N 293 550 010



F001 001 041

Jet Pump Synthetic Oil

P / N 293 600 011



F001 001 025

Spray Paint for Metallic Parts Only

Mauve

P / N 293 500 020

White

P / N 293 500 029



F001 001 026

Dielectric Grease

P / N 293 550 004



F001 001 042

PRODUCTS

Anti-seize Lubricant
P / N 293 800 023



F001 001 043

Sea-Doo Lube
P / N 293 600 006



F001 001 028

Gelcote® Repair Kit
P / N 295 500 009



F001 001 027

PRODUCTS

Injection Oil
1 liter P / N 293 600 005
4 liters P / N 293 600 004

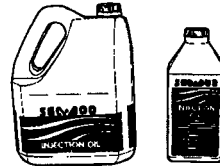

F001 001 044

Pipe Sealant
P / N 293 800 018



A000 001 104

Tube Repair Kit
P / N 204 000 046

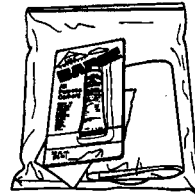

F003 015 002

Fuel Stabilizer
P / N 413 408 600



A000 001 139

OTHER PUBLICATIONS AVAILABLE

PUBLICATION	P / N
Shop Manual	219 100 010
Sea-Doo Racing Handbook	219 100 016

WATERCRAFT MODEL No. _____

HULL

IDENTIFICATION NUMBER (H.I.N.) _____

ENGINE

IDENTIFICATION NUMBER (E.I.N.) _____

Purchase Date _____ | _____ | _____ | _____ | _____
 year month day

Warranty Expiry Date _____ | _____ | _____ | _____ | _____
 year month day

To be completed by the dealer at the time of the sale

DEALER IMPRINT AREA

Please verify with your selling dealer to ensure your SEA-DOO watercraft has been registered with Bombardier.

CHANGE OF ADDRESS OR OWNERSHIP

If your address or owner has changed, be sure to fill out and mail the card provided on next page.

Such notification is likewise necessary for your own safety even after expiration of the original warranty, since Bombardier will be in a position to contact you if correction to your watercraft becomes necessary.

NOTICE TO ALL NEW OWNERS : Make sure to receive the warranty registration card from the previous owner, when the ownership is transferred, as you may be entitled to the unexpired portion of the warranty.

NOTE : This card is strictly for change of address / ownership only.

CHANGE OF ADDRESS / OWNERSHIP CARD

CHANGE OF ADDRESS

CHANGE OF OWNERSHIP

WATERCRAFT
IDENTIFICATION NUMBER

--	--	--	--	--

Model Number

--	--	--	--	--	--	--	--	--	--	--	--	--	--	--	--	--	--	--	--

Hull Identification Number (H.I.N.)

OLD ADDRESS
OR PREVIOUS OWNER :

NAME

NO

STREET

APT

CITY

STATE / PROVINCE

ZIP / POSTAL CODE

NEW ADDRESS
OR NEW OWNER :

NAME

NO

STREET

APT

CITY

STATE / PROVINCE

ZIP / POSTAL CODE

STAMP

BOMBARDIER INC.
SEA-DOO WARRANTY
VALCOURT, QUEBEC
CANADA J0E 2L0



P219000017

CA2001