

ski-doo®



2008

**Operator's
Guide**

**SKANDIC™ WT/SWT/SUV
EXPEDITION™ TUV**

**Includes
Safety, Vehicle
and Maintenance Information**



WARNING

Read this guide thoroughly. It contains important safety information. Minimum recommended operator's age: 16 years old. Minimum recommended passenger's age (if applicable): 16 years old. Do not remove this Operator's Guide from the vehicle.

5 2 0 0 0 0 7 4 5

SAFETY WARNING

Disregarding any of the safety precautions and instructions contained in this Operator's Guide, *SAFETY VIDEO* or on-product warnings may result in injury, including the possibility of death.

This Operator's Guide and *SAFETY VIDEO* should remain with the snowmobile at time of resale.



In USA, products are distributed by BRP US Inc.

In Canada, products are distributed by Bombardier Recreational Products Inc.

The following are trademarks of Bombardier Recreational Products Inc. or its subsidiaries.

ROTAX™

SKANDIC™

SKI-DOO®

EXPEDITION™

DESS™

XP-STM

FOREWORD

Congratulations on your purchase of a new SKI-DOO® snowmobile. Whatever model you have chosen, it is backed by the Bombardier Recreational Products Inc. (BRP) warranty and a network of authorized SKI-DOO snowmobile dealers ready to provide the parts, service or accessories you may require.

The Operator's Guide has been prepared to acquaint the owner/operator and passenger with this new snowmobile and its various controls, maintenance and safe riding instructions. This guide is indispensable for the proper use of the product and should be kept with this snowmobile at all times.

Make sure you read and understand the content of this Operator's Guide.

After reading, please keep this Operator's Guide with the snowmobile. If the snowmobile is resold, please give the guide to the new owner for his awareness.

If you want to view and/or print an extra copy of your Operator's Guide, simply visit the following website www.operatorsguide.brp.com. Also note that the guide may be available in several languages.

If you have any question regarding any topic whether or not it is covered in this Operator's Guide, please call BRP at the number below and we will be happy to assist you:

In USA:
715 848-4957

In Canada:
819 566-3366

For Russia, CIS and the middle east:
+ 32 9 218 26 00

For Scandinavian and European countries:
+ 358 16 3208 111

For all other countries, please contact your respective distributor (his coordinates are on www.brp.com) or our North American office:
+ 1 819 566-3366

This guide uses the following safety alert symbol in conjunction with signal words to indicate a potential personal injury hazard.

WARNING

Indicates a potentially hazardous situation which, if not avoided, could result in death or serious injury.

CAUTION

Indicates a potentially hazardous situation which, if not avoided, may result in minor or moderate injury. When used without the safety alert symbol , potential hazard exists for property damage only.

NOTE: Indicates supplementary information needed to fully complete an instruction.

Although the mere reading of such information does not eliminate the hazard, the understanding and application of the information will promote the correct use of the vehicle.

Your dealer is committed to your satisfaction. He has taken training to perform the initial set-up and inspection of your snowmobile as well as completed the final adjustment required to suit your specific weight and riding environment before you took possession. At delivery, your dealer would have explained the snowmobile controls and provided you with a brief explanation of the various suspension adjustments. We trust you have taken full advantage of this!

At delivery, you were also informed of the warranty coverage and have completed the Warranty Registration process.

The information and components/system descriptions contained in this guide are correct at time of publication. BRP, however maintains a policy of continuous improvement of its products without imposing upon itself any obligation to install them on products previously manufactured.

Because of its ongoing commitment to product quality and innovation, BRP reserves the right at any time to discontinue or change specifications, designs, features, models or equipment without incurring obligation.

The illustrations in this document show the typical construction of the different assemblies and, in all cases, may not reproduce the full detail or exact shape of the parts shown, however, they represent parts which have the same or a similar function.

It is understood that this guide may be translated into another language. In the event of any discrepancy, the English version shall prevail.

Specifications are given in the SI metric system with the SAE U.S. equivalent in parentheses. Where precise accuracy is not required, some conversions are rounded off for easier use.

Most components of this snowmobile are built with parts dimensioned in the metric system. Most fasteners are metric and must not be replaced by customary fasteners or vice versa.

We recommend genuine BRP products for replacement parts and accessories. They've been specially designed for your vehicle and manufactured to meet BRP's demanding standards.

A *SHOP MANUAL* can be obtained for complete service, maintenance and more repair information.

For any questions pertaining to the warranty and its application, consult the *WARRANTY* section in this guide, and/or an authorized SKI-DOO dealer.

TABLE OF CONTENTS

SAFETY INFORMATION

INTRODUCTION	8
IMPORTANT BASIC SAFETY MEASURES	9
LAWS AND REGULATIONS	13
RIDING THE VEHICLE	14
Principle of Operation	14
How to Ride	14
Carrying a Passenger	16
Terrain/Riding Variations	18
Transporting and Towing	22
LOCATION OF THE IMPORTANT LABELS	23

ENVIRONMENT INFORMATION

GENERAL	28
JUST WHAT IS LIGHT TREADING?	29
WHY IS LIGHT TREADING SMART	30

VEHICLE INFORMATION

HOW TO IDENTIFY YOUR SNOWMOBILE	32
CONTROLS/INSTRUMENTS/EQUIPMENT	34
1) Throttle Lever	35
2) Brake Lever	35
3) Parking Brake Lever	35
4) Pilot Lamps	35
5) Gear Shift Lever	36
6) Handlebar	37
7) Holding Strap	37
8) Ignition Switch/Start Button	37
9) Tether Cut-Out Switch	38
10) Engine Cut-Out Switch	39
11) Headlamp Dimmer Switch	40
12) Rewind Starter Handle	40
13) Choke Lever	40
14) Speedometer	41
15) Odometer	41
16) Trip Meter/Display	41
17) Mode Button	42
18) Fuel Tank Cap	42
19) Heated Grip Switch	42
20) Heated Throttle Lever Switch	42

21) Hood Latches	42
22) Electric Power Outlet	42
23) Fuses	43
24) Front Grab Handles/Front Bumper	45
25) Storage Compartment	45
26) Rear Rack	46
27) Tool Kit	46
28) Hitch	46
29) Shields and Guards	46
30) Windshield	46
31) Modular Seat	46
32) Backrest	47
33) Rear Grab Handles/Heated Grips Switch	48
34) Tachometer	48
35) Electric Fuel Level Gauge	48
36) Temperature Gauge	49
37) Adjustable Mirrors	49
38) Mechanical Fuel Level Gauge	49

RECOMMENDED FUEL AND OIL **50**

BREAK-IN PERIOD..... **53**

OPERATING INSTRUCTIONS..... **54**

Pre-Operation Check	54
SDI Engine Starting Procedure	55
Carburetor Engine Starting Procedure	56
Engine Starting Procedure (4-stroke)	57
Vehicle Warm-Up	57
Shutting Off the Engine	58
Post-Operation Care	58

SPECIAL OPERATING INSTRUCTIONS..... **59**

Riding at High Altitudes	59
Riding in Cold Weather	59
Emergency Starting	59
Towing an Accessory	60
Towing Another Snowmobile	60
Towing an Heavy Load at Low Speed	60
Transporting the Vehicle.....	61

SUSPENSION ADJUSTMENTS **62**

TROUBLESHOOTING **69**

SPECIFICATIONS **73**

MAINTENANCE INFORMATION

PERIODIC MAINTENANCE CHART **88**

2-Stroke	89
4-Stroke	92

ENGINE SYSTEM	95
Air Filter Cleaning	95
Cooling System	95
Exhaust System.....	96
Injection Oil Level (2-stroke engines).....	96
Engine Oil Level (4-stroke engines).....	97
EPA Certified Engines	98
DRIVE SYSTEM	100
Brake Fluid Level.....	100
Brake Condition	100
Brake Adjustment.....	100
Gearbox Oil Level.....	100
Belt Guard Removal and Installation.....	100
Drive Belt Condition	101
Drive Belt Removal/Installation.....	101
Drive Belt Height Adjustment	102
Drive Pulley Adjustment	103
Track Condition.....	104
Track Adjustments	105
ELECTRICAL SYSTEM	108
Battery Electrolyte	108
REAR SUSPENSION	109
STEERING AND FRONT SUSPENSION	110
BODY/FRAME	111
Vehicle Cleaning and Protection.....	111
Bulb Replacement	111
STORAGE AND PRESEASON PREPARATION	113

WARRANTY

BRP LIMITED WARRANTY NORTH AMERICA: 2008 SKI-DOO® SNOWMOBILES	116
BRP INTERNATIONAL LIMITED WARRANTY: 2008 SKI-DOO® SNOWMOBILES	121
BRP EUROPEAN UNION MEMBER STATES LIMITED WARRANTY: 2008 SKI-DOO® SNOWMOBILES	125
PRIVACY OBLIGATIONS/DISCLAIMER	129
CHANGE OF ADDRESS/OWNERSHIP	130

SAFETY INFORMATION

INTRODUCTION

Everyone is a beginner the first time he sits behind the controls of a snowmobile regardless of previous experience in driving an automobile, a motorcycle or a motorboat. The safe use of your snowmobile is dependent on many conditions such as visibility, speed, weather, environment, traffic, vehicle condition and the condition of the driver.

Each operator has a responsibility to ensure the safety of his/her passenger, if any, and of other recreationists or bystanders.

You are responsible for proper operation of your vehicle as well as training those whom you allow to ride or drive. There may be noticeable handling and performance differences from one snowmobile to the other.

A snowmobile is relatively simple to operate but like any other vehicle or mechanical equipment, it can be hazardous if you or a passenger are reckless, thoughtless or inattentive. We encourage you to have an Annual Safety Inspection of your snowmobile. Please contact an authorized SKI-DOO dealer for further details. Finally, we urge you to visit an authorized SKI-DOO dealer periodically for regular and safety maintenance, as well as snowmobile accessories you may require.

IMPORTANT BASIC SAFETY MEASURES

Training

- △ Basic training is required for the safe operation of any snowmobile. Study your Operator's Guide paying particular attention to cautions and warnings. Join your local snowmobile club: its social activities and trail systems are planned for both fun and safety. Obtain basic instructions from your snowmobile dealer, friend, fellow club member or enroll in your state or provincial safety training program.
- △ Always show a new operator how to start and stop the vehicle. Indicate the correct riding positions and, above all else, only allow him to operate the snowmobile in a restricted flat area — at least until he is completely familiar with its operation. If there is a local snowmobile operator's training course existing, have him enroll.

Performance

- △ The performance of some snowmobiles may significantly exceed that of other snowmobiles you have operated. Therefore, use by novice or inexperienced operators is not recommended.
- △ Snowmobiles are used in many areas and in many snow conditions. Not all models perform the same in similar conditions. Always consult your snowmobile dealer when selecting the snowmobile model for your particular needs and uses.
- △ Injury or death may result to the snowmobile operator, passenger or bystander if the snowmobile is used in risky conditions which are beyond the driver's, passenger's or snowmobile's capabilities or intended use.

Age

- △ BRP recommends the operator has at least 16 years old of age.

Speed

- △ Speeding can be fatal. In many cases, you cannot react or respond quickly enough to the unexpected. Always ride at a speed which is suitable to the trail, weather conditions and your own ability. Know your local rules. Speed limit may be in effect and meant to be observed.

Riding

- △ Always keep right hand side of the trail.
- △ Always keep a safe distance from other snowmobiles and bystanders.
- △ Remember, promotional material may show risky maneuvers performed by professional riders under ideal and/or controlled conditions. You should never attempt any such risky maneuvers if they are beyond your level of riding ability.
- △ Never ride after consuming drugs or alcohol or if you feel tired or ill. Operate your snowmobile prudently.
- △ Your snowmobile is not designed to be operated on public streets, roads or highways.
- △ Snowmobiling at night can be a delightful experience but because of reduced visibility, be extra cautious. Avoid unfamiliar terrain and be sure your lights are working. Always carry a flashlight and spare light bulbs.

- ⚠ Nature is wonderful but don't let it distract your attention from driving. If you want to truly appreciate winter's scenery, stop your snowmobile on the side of the trail so that you don't become a hazard to others.
- ⚠ Fences represent a very serious threat for both you and your snowmobile. Give a wide berth to telephone poles or posts.
- ⚠ Hidden wires unseen from a distance can cause serious accidents.
- ⚠ Always wear an approved safety helmet, eye protection and a face shield. This also applies to your passenger.
- ⚠ Be aware of inherent risks associated with riding off trails, such as avalanche and other natural or man made hazards or obstacles.
- ⚠ Avoid road traveling. If you must do so, and it is permitted, reduce speed. The snowmobile is not designed to operate or turn on paving. When crossing a road, make a full stop, then look carefully in both directions before crossing at a 90° angle. Be wary of parked vehicles.
- ⚠ Tailgating another snowmobile should be avoided. If the snowmobile in front of you slows for any reason, its driver and passenger could be harmed through your neglect. Maintain a safe stopping distance between you and the snowmobile in front of you. Depending on the terrain condition, stopping may require a little more space than you think. Play it safe. Be prepared to use evasive driving.
- ⚠ Venturing out alone with your snowmobile could also be hazardous. You could run out of fuel, have an accident, or damage your snowmobile. Remember, your snowmobile is capable of traveling further in half an hour than you may be able to walk in a day. Use the "buddy system". Always ride with a friend or member of your snowmobile club. Even then, tell someone where you are going and the approximate time you plan to return.
- ⚠ Meadows sometimes have low areas where water accumulate and freezes over in winter. This ice is usually glare ice. Attempting to turn or brake on this surface could cause your vehicle to spin out of control. Never brake or attempt speeding or turning on glare ice. If you do happen to travel over such a condition, reduce speed by carefully releasing the throttle.
- ⚠ Never "jump" with your snowmobile. This should be left to professional stunt men. Don't show off. Be responsible.
- ⚠ While on safari, do not "gun" the throttle. Snow and ice can be thrown back into the path of a following snowmobile. In addition, when "gunning" the throttle, the vehicle digs into and leaves an irregular snow surface for others.
- ⚠ Safaris are both fun and enjoyable but don't show off or overtake others in the group. A less experienced operator might try to do the same as you and fail. When riding with others, limit your abilities to the experience of others.

Operation

- ⚠ Always make a pre-start inspection BEFORE you turn on the ignition.
- ⚠ In an emergency, the snowmobile engine can be stopped by pressing down on the engine cut-out switch, pulling the tether cord cap (DESS™ key) or turning off the ignition switch key.
- ⚠ Throttle mechanism should be checked for free movement and return to idle position before starting engine.
- ⚠ Always engage parking brake when vehicle is not in use.
- ⚠ Never run the engine in a non-ventilated area and/or if vehicle is left unattended.
- ⚠ Never operate the engine without belt guard securely installed or, with hood or access/side panels opened or removed. Never run the engine without drive belt installed. Running an unloaded engine such as without drive belt or with track raised, can be dangerous.
- ⚠ **Electric start models only:** Never charge or boost a battery while installed on snowmobile.
- ⚠ Ensure the path behind is clear of obstacles or bystanders before proceeding in reverse.
- ⚠ Always remove the ignition key (if applicable) or the tether cord cap (DESS key) when vehicle is not in operation in order to prevent accidental engine starting, to avoid unauthorized use by children or others or theft.

- ⚠ Raising the rear of your snowmobile while the engine is running could cause snow, ice or debris to be thrown back at an observer. Never raise the rear of the vehicle while the engine is running. To clear or inspect the track, stop the engine, tilt the vehicle on its side and remove blockage with a piece of wood or branch. Never allow anyone near a rotating snowmobile track.

Maintenance

- ⚠ Know your snowmobile and treat it with the respect and care due of any power driven machine. Common sense, proper handling and routine maintenance will result in safer and enjoyable use.
- ⚠ Only perform procedures as detailed in this guide. Unless otherwise specified, engine should be turned OFF and cold for all lubrication, adjustment and maintenance procedures.
- ⚠ Never have the engine running while the hood or access/side panels are opened. Even at idle, a snowmobile engine is turning around 1800 RPM. Always turn off the engine before opening the hood and/or side panels for any reason.
- ⚠ Never remove any original equipment from your snowmobile. Each vehicle has many built in safety features. Such features include various guards and consoles, plus reflective materials and warning labels.

- ⚠ A poorly maintained snowmobile itself can be a potential hazard. Excessively worn components could render the vehicle completely inoperative. Keep the snowmobile in good working condition at all times. Follow your pre-operation check, weekly, monthly and annually routine maintenance and lubrication procedures as detailed in this guide. Consult a snowmobile dealer or acquire a shop manual and proper tools and equipment if other repairs or service is required.
- ⚠ Do not stud the track unless it has been approved for studs. At speed, a studded track that has not been approved for studs could tear and separate from vehicle posing a risk of severe injury or death.
- ⚠ Always wear a DOT approved helmet and follow the same dressing guidelines as those recommended for the operator and described in this guide.
- ⚠ Make sure that you are able to achieve a stable stance, both feet resting positively on the footboards of footrests with good grip, and that you are able to hold on firmly to the handholds.
- ⚠ Once underway, if you feel uncomfortable or insecure for any reason, don't wait, tell the driver to slow down or stop.

Fuel

- ⚠ Always stop the engine before refueling. Fuel is flammable and explosive under certain conditions. Always work in a well-ventilated area. Do not smoke or allow open flames or sparks in the vicinity. Open cap slowly. If a differential pressure condition is noticed (whistling sound heard when loosening fuel tank cap) have vehicle inspected and/or repaired before further operation. Do not overfill or top off the fuel tank before placing the vehicle in a warm area. As temperature increases, fuel expands and might overflow. Always wipe off any fuel spillage from the vehicle. Periodically verify fuel system.

Basics for Passenger

- ⚠ Never ride as a passenger unless the snowmobile is equipped with a passenger seat, and sit only on the designated passenger seat.

LAWS AND REGULATIONS

⚠ Know your local laws.

Federal, state, provincial and local government agencies have enacted laws and regulations pertaining to the safe use and operation of snowmobiles. It is your responsibility as a snowmobiler to learn and obey these laws and regulations. Respect and observance will result in safer snowmobiling for all.

Be aware of the liability property damages and insurance laws regarding your equipment.

RIDING THE VEHICLE

Before venturing on the trails, operate the snowmobile in a restricted flat area until you are completely familiar with its operation and feel comfortable that you can safely tackle a more demanding task. Have an enjoyable and safe ride.

Principle of Operation

Propulsion

Depressing throttle lever increases engine RPM causing the drive pulley to engage. Depending on models engine RPM must be between 2500 and 4200 before drive pulley engagement will occur.

Outer sheave of drive pulley moves toward inner sheave, forcing the drive belt to move upward on the drive pulley and simultaneously forcing the sheaves apart on the driven pulley.

The driven pulley senses the load on the track and limits the belt movement. The result is an optimized speed ratio between engine RPM and the speed of the vehicle at any time.

WARNING

Never operate engine without belt guard securely installed or, with hood or access/side panels opened or removed.

Power is transferred to the track through the chaincase or gearbox and drive axle.

WARNING

Always use a wide-base snowmobile mechanical stand to properly support vehicle during any track verification. Slowly accelerate engine in order to rotate track at very low speed when it is not on ground.

Turning

Handlebar controls the steering of the vehicle. As the handlebar is rotated to right or left, the skis are turned right or left to steer the snowmobile.

Stopping

Before riding your snowmobile, you should understand how to stop it. This is done by releasing the throttle and gradually depressing the brake lever on the left side of the handlebar. In an emergency, you may stop your vehicle by pressing the engine cut-out switch located near the throttle control and applying the brake. Remember, a snowmobile cannot "stop on a dime". Braking characteristics vary with deep snow, packed snow or ice. If the track is locked during hard braking, skidding may result.

How to Ride

How to Dress

Proper snowmobile clothing should be worn. It should be comfortable and not too tight. Always check the weather forecast before going on a ride. Dress for the coldest weather expected. Thermal underwear next to the skin also provides a good insulation.

DOT approved helmets are recommended at all times. They provide both warmth and reduce injury. A stocking type cap, balaclava and face mask should always be carried or worn. Goggles or a face shield that attach to the helmet are indispensable.

Hands should be protected by a pair of snowmobile gloves or mitts which have sufficient insulation and allow use of thumbs and fingers for operation of controls.

Rubber bottom boots with either a nylon or a leather top, with removable felt liners are best suited for snowmobiling.

You should keep yourself as dry as possible when snowmobiling. When you come indoors, take your snowmobile suit and boots off and make certain they dry properly.

Do not wear long scarfs and loose apparel that could get caught in moving parts.

What to Bring

Every snowmobiler should carry at least the following basic parts and tools that can help him and others in an emergency:

- this Operator's Guide
- spare spark plugs and wrench
- friction tape
- spare drive belt
- spare starter rope
- spare light bulbs
- tool kit (including at least pliers, screwdriver, adjustable wrench)
- knife
- flashlight.

Include other items depending on the length and time of your ride.

Riding Position

Your riding position and balance are the two basic principles of making your snowmobile go where you want it to. When turning on the side of a hill, you and your passenger must be ready to shift body weight to help it turn in the desired direction. Driver and passenger(s) must never attempt this maneuvering by placing feet outside of the vehicle. Experience will teach you how much lean to put into turns at different speeds and how much you will have to lean into a slope to maintain proper balance.

Generally, the riding position for best balance and control is sitting. However, the posting, kneeling or standing positions are also used under certain conditions.

The novice driver should become familiar with the snowmobile through practice on a level area at slow speeds before venturing afield.

⚠ WARNING
Do not attempt any maneuvers if they are beyond your abilities.

Sitting

Feet on the running boards, body mid-way back on seat is an ideal position when operating the snowmobile over familiar, smooth terrain. Knees and hips should remain flexible to absorb shocks.



Posting

A semi-sitting position with the body off the seat and the feet under the body in a sort of squatting posture, thus allowing the legs to absorb the shocks when traveling over uneven terrain. Avoid abrupt stops.



Standing

Place both feet on the running boards. Knees should be flexed to absorb the shock from surface bumps. This is an effective position to see better and to shift weight as conditions dictate. Avoid abrupt stop.



Kneeling

This position is achieved by placing one foot firmly on the running board and the opposite knee on the seat. Avoid abrupt stops.



Carrying a Passenger

Certain snowmobiles are designed for an operator only, others can allow one passenger only, and others can allow up to two passengers. Refer to the indications on the vehicles to know if any particular snowmobile can accommodate passengers or not, and if so, how many. Always respect those indications. Overloading is dangerous because snowmobiles are not designed for it.

Even when passengers are allowed, you must make sure that the persons who would like to become passengers are physically fit for snowmobiling.

WARNING

Any passenger must be able to firmly lay his feet on the footrests and keep his hands on the grab handles or seat strap at all times when seated. Respecting those physical criteria is important to ensure that the passenger is stable and to reduce the risks of ejection.

On snowmobiles allowing two passengers, if you have an adult and a child for passenger, BRP recommends that the child sits in the center location. This allows an adult sitting in the rear seat to keep a visual contact with the child and hold him if necessary. In addition, the child is best protected against the wind and cold temperature if seated in the center location.

Each operator has a responsibility to ensure the safety of his passengers and should inform them of snowmobiling basics.

WARNING

- Passengers must only sit on designated passenger seats. Never allow anyone to sit between the handlebar and the operator.
- Each passenger seat must have a strap or grab handles and meet SSCC standards.
- Passengers and operators must always wear DOT approved helmets and warm clothing appropriate for snowmobiling. Make sure that no skin is exposed.
- Once underway, if a passenger feels uncomfortable or unsecure for any reason, he must not wait, and tell the driver to slow-down or stop.

Riding with passengers on board is different than riding alone. The operator has the benefit of knowing what will be the next maneuver and is able to prepare himself accordingly. The operator also benefits from the support of his grip on the handlebar. In contrast, the passengers have to rely on the operator's careful and safe operation of the vehicle. In addition, "body english" is limited with passengers, and the operator can sometimes see more of the trail ahead than the passengers. Therefore, smooth starting and stopping are required with passengers, and the operator must slow down. The operator must also warn passengers of side hills, bumps, branches, etc. An unforeseen bump can leave you passenger-less. Remind your passengers to lean into the turn with you, without causing the vehicle to topple. Be extremely careful, go more slowly and check the passengers frequently.

WARNING

When riding with a passenger:

- Braking ability and steering control are reduced. Decrease speed and allow extra space to maneuver.
- Adjust suspension according to weight.

For complete information on how to adjust the suspension, please refer to the section of this Operator's Guide entitled *SUSPENSION ADJUSTMENTS*.

Use extra caution and go even more slowly with young passengers. Check frequently to make certain the child has a firm grip and is properly positioned with his feet on the running boards.

Terrain/Riding Variations

Groomed Trail

On a maintained trail, sitting is the most preferred riding position. Do not race and, above all, keep to the right hand side of the trail. Be prepared for the unexpected. Observe all trail signs. Do not zigzag from one side of the trail to the other.

Ungroomed Trail

Unless there has been a fresh snowfall you can expect "washboard" and snowdrift conditions. Taken at excessive speeds, such conditions can be physically harmful. Slow down. Hold on the handlebar and assume a posting position. Feet should be under the body assuming a crouched position to absorb any jarring effect. On longer stretches of "washboard" trails, the kneeling position of one knee on the seat can be adopted. This provides a certain amount of comfort, while at the same time keeps the body loose and capable of vehicle control. Beware of hidden rocks or tree stumps partially hidden by a recent snowfall.

Deep Snow

In deep "powder" snow, your vehicle could begin to "bog" down. If this occurs, turn in as wide an arc as possible and look for a firmer base. If you do get "bogged", and it happens to everyone, do not spin your track as this makes the vehicle sink deeper. Instead, turn the engine off, get off and move the back of the vehicle onto new snow. Then tramp a clear path ahead of the vehicle. A few feet will generally suffice. Restart the engine. Assume the standing position and rock the vehicle gently as you steadily and slowly apply the throttle. Depending on whether the front or rear end of the vehicle is sinking, your feet should be placed on the opposing end of the running boards. Never place foreign material beneath the track for support. Do not allow anyone to stand in front of, or to the rear of, the snowmobile with the engine running. Stay away from the track. Personal injury will result if contact is made with the revolving track.

Frozen Water

Traveling frozen lakes and rivers can be fatal. Avoid waterways. If you are in an unfamiliar area, ask the local authorities or residents about the ice condition, inlets, outlets, springs, fast moving currents or other hazards. Never attempt to operate your snowmobile on ice that may be too weak to support you and the vehicle. Operating a snowmobile on ice or icy surfaces can be very dangerous if you do not observe certain precautions. The very nature of ice is foreign to good control of a snowmobile or any vehicle. Traction for starting, turning or stopping is much less than that on snow. Thus, these distances can be multiplied manyfold. Steering is minimal, and uncontrolled spins are an ever present danger. When operating on ice, drive slowly with caution. Allow yourself plenty of room for stopping and turning. This is especially true at night.

Hard Packed Snow

Don't underestimate hard packed snow. It can be difficult to negotiate as both skis and track do not have as much traction. Best advice is to slow down and avoid rapid acceleration, turning or braking.

Uphill

There are two types of hills you can encounter — the open hill on which there are few trees, cliffs or other obstacles, and a hill that can only be climbed directly. On an open hill, the approach is to climb it by side hilling or slalom-ing. Approach at an angle. Adopt a kneeling position. Keep your weight on the uphill side at all times. Maintain a steady, safe speed. Continue as far as you can in this direction, then switch to an opposite hill angle and riding position.

A direct climb could present problems. Choose the standing position, accelerate before you start the climb and then reduce throttle pressure to prevent track slippage.

In either case, vehicle speed should be as fast as the incline demands. Always slow down as you reach the crest. If you cannot proceed further, don't spin your track. Turn the engine off, free the skis by pulling them out and downhill, place the rear of the snowmobile uphill restart the engine and ease it out with slow even throttle pressure. Position yourself to avoid tipping over, then descend.

Downhill

Downhill driving requires that you have full control of your vehicle at all times. On steeper hills, keep your center of gravity low and both hands on the handlebar. Maintain slight throttle pressure and allow the machine to run downhill with the engine operating. If a higher than safe speed is reached, slow down by braking but apply the brake with frequent light pressure. Never jam the brake and lock the track.

Side Hill

When crossing a side hill or traversing up or downhill, certain procedures must be followed. All riders should lean towards the slope as required for stability. The preferred operating positions are the kneeling position, with the knee of the down hill leg on the seat and the foot of the uphill leg on the running board, or the posting position. Be prepared to shift your weight quickly as needed. Side hills and steep slopes are not recommended for a beginner or a novice snowmobiler.

Slush

Slush should be avoided at all times. Always check for slush before starting across any lake or river. If dark spots appear in your tracks, get off the ice immediately. Ice and water can be thrown rearward into the path of a following snowmobile. Getting a vehicle out of a slush area is strenuous and in some cases, impossible.

Fog or Whiteouts

On land or water, fog or visibility-limiting snow can form. If you have to proceed into the fog or heavy snow, do so slowly with your lights on and watch intently for hazards. If you are not sure of your way, do not proceed. Keep a safe distance behind other snowmobilers to improve visibility and reaction time.

Unfamiliar Territory

Whenever you enter an area that is new to you, drive with extreme caution. Go slow enough to recognize potential hazards such as fences or fence posts, brooks crossing your path, rocks, sudden dips, guy wires and countless other obstacles which could result in a termination of your snowmobile ride. Even when following existing tracks, be cautious. Travel at a speed so you can see what is around the next bend or over the top of the hill.

Bright Sunshine

Bright sunny days can considerably reduce your vision. The glare from sun and snow may blind you to the extent that you cannot easily distinguish ravines, ditches or other obstacles. Goggles with colored lenses should always be worn under these conditions.

Unseen Obstruction

There may be obstructions hidden beneath the snow. Driving off established trails and in the woods requires reduced speed and increased vigilance. Driving too fast in an area can make even minor obstacles very hazardous. Even hitting a small rock or stump could throw your snowmobile out of control and cause injury to its riders. Stay on established trails to reduce your exposure to hazards. Be safe, slow down and enjoy the scenery.

Hidden Wires

Always be on the lookout for hidden wires, especially in areas that may have been farmed at one time or another. Too many accidents have been caused by running into wires in the fields, guy wires next to poles and roads, and into chains and wires used as road closures. Slow speeds are a must.

Obstacles and Jumping

Unplanned jumps of snowdrifts, snowplow ridges, culverts or indistinguishable objects can be dangerous. You can avoid them by wearing the proper color lenses or face shields and by operating at a lower speed.

Jumping a snowmobile is an unsafe and dangerous practice. However, if the trail does suddenly drop away from you, crouch (stand) towards the rear of the vehicle and keep the skis up and straight ahead. Apply partial throttle and brace yourself for the impact. Knees must be flexed to act as shock absorbers.

Turning

Depending on terrain conditions, there are two preferred ways to turn or corner a snowmobile. For most snow surfaces, “body english” is the key to turning. Leaning towards the inside of the turn and positioning body weight on the inside foot will create a “banking” condition beneath the track. By adopting this position and positioning yourself as far forward as possible, weight will be transferred to the inside ski.

On occasion, you will find that the only way to turn the vehicle about in deep snow is to pull the snowmobile around. Do not over-exert yourself. Get assistance. Remember to always lift using your legs as opposed to your back.



Road Crossing

In some cases, you will be approaching the road from a ditch or snowbank. Choose a place where you know you can climb without difficulty. Use the standing position and proceed with only as much speed needed to crest the bank. Stop completely at the top of the bank and wait for all traffic to clear. Judge the drop to the roadway. Cross the road at a 90° angle. If you encounter another snowbank on the opposite side, position your feet near the rear of the vehicle. Remember, your snowmobile is not designed to operate on bare pavement and steering on this type of surface is more difficult.

Railroad Crossing

Never ride on railroad tracks. It is illegal. Railroad tracks and railroad rights-of-way are private property. A snowmobile is no match for a train. When crossing a railroad track, stop, look and listen.

Night Rides

The amount of natural and artificial light at a given time can effect your ability to see or to be seen. Nighttime snowmobiling is delightful. It can be a unique experience if you acknowledge your reduced visibility. Before you start, make certain your lights are clean and work properly. Drive at speeds that will allow you to stop in time when you see an unknown or dangerous object ahead. Stay on established trails and never operate in unfamiliar territory. Avoid rivers and lakes. Guy wires, barbed wire fences, cabled road entrances and other objects such as tree limbs are difficult to see at night. Never drive alone. Always carry a flashlight. Keep away from residential areas and respect the right of others to sleep.

Safari Riding

Before starting out, designate a “trail boss” to lead the party and another person to follow-up at the end of the party. Ensure that all members of the party are aware of the proposed route and destination. Make certain that you are carrying all necessary tools and equipment and that you have sufficient fuel to complete the trip. Never overtake the trail boss or, for that matter, any other snowmobile. Use down-the-line hand signals to indicate hazards or intent of direction change. Assist others whenever necessary.

It is always IMPORTANT to keep a safe distance between each snowmobile. Always maintain a safe interval and allow sufficient stopping distance. Don't be a tailgater. Know the position of the machine ahead.

Signals

If you intend to stop, raise either hand straight above your head. A left turn is indicated by extending your left hand straight out in the proper direction. For right turns, extend the left arm and raise the hand to a vertical position so it forms a right angle at the elbow. Every snowmobiler should relay any signal to the ones behind.

Trail Stops

Whenever possible, pull off the trail when you stop. This will reduce the hazard to other snowmobilers using the trail.

Trails and Signs

Trail signs are used to control, direct or regulate the use of snowmobiles on trails. Become familiar with all signs used in the area where you are snowmobiling.

Transporting and Towing

Follow transporting and towing instructions explained further in this guide.

LOCATION OF THE IMPORTANT LABELS

Safety standards for snowmobiles have been adopted by the Snowmobile Safety and Certification Committee (SSCC) of which BRP is a proud participating member. Assurance that your snowmobile meets these standards is easily checked by locating the Certification Label on a right vertical portion of the vehicle.

This label shows that an independent testing laboratory has verified compliance with the SSCC safety standards.



Other important labels on the vehicle are WARNING or CAUTION labels relating to safety, maintenance and/or snowmobile operation. Ensure all such labeling is retained on the vehicle and its content is followed by vehicle operator and passenger.

If missing or damaged, the decals can be replaced free of charge. See an authorized SKI-DOO dealer.

Please read the following instructions carefully before operating this snowmobile.

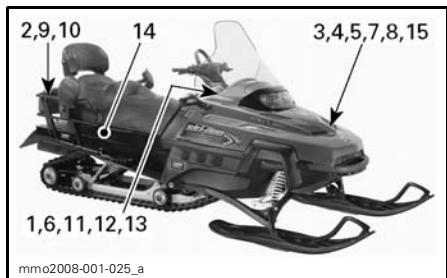

TYPICAL — LOCATION OF IMPORTANT INSTRUCTIONS

Instruction 1

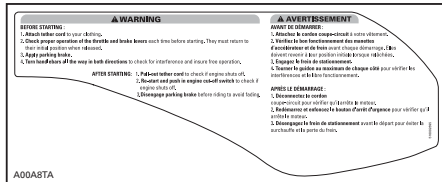

Instruction 2

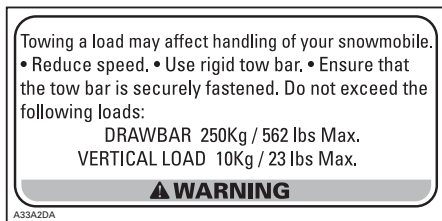

Instruction 3

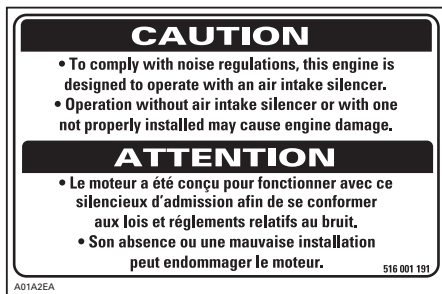

Instruction 4

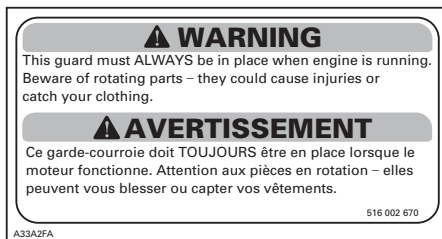

Instruction 5

CAUTION	ATTENTION
<p>Checking Engine Oil Level!</p> <ul style="list-style-type: none"> Make sure engine is at operating temperature. Snowmobile must be on a level surface. Let engine running at idle for at least 30 seconds. Stop engine & wipe the dipstick. Dipstick must be screwed in completely before checking oil level. Use BOMBARDIER synthetic oil 0W40. 	<p>Vérification du niveau d'huile moteur</p> <ul style="list-style-type: none"> S'assurer que le moteur est à la température normale d'opération. La motoneige doit être de niveau. Laisser tourner le moteur au ralenti 30 secondes minimum. Arrêter le moteur et nettoyer la jauge de niveau d'huile. Visser la jauge complètement avant de mesurer le niveau d'huile. Utiliser de l'huile synthétique BOMBARDIER 0W40.

A32A1ZA

V800 MODEL

Instruction 6

CAUTION
<ul style="list-style-type: none"> Upshift only when engine is idling and speed is below 20 km/h (12 m.p.h.). Stop completely the vehicle before using reverse gear. Maximum speed in first gear 60 km/h (37 m.p.h.).
ATTENTION
<p>Changer les rapports avant seulement lorsque le régime du moteur est au ralenti et la vitesse inférieure à 20 km/h (12 m.p.h.).</p> <ul style="list-style-type: none"> Arrêter complètement le véhicule avant de passer en marche arrière. Vitesse maximum en premier rapport 60 km/h (37 m.p.h.).

R

516 001 201

A29A0IA

Instruction 7

⚠ WARNING

Beware of **HOT** parts!

⚠ AVERTISSEMENT

Attention aux pièces **CHAUDES**!

516002664

A32A2GA

Instruction 8



LIQUID-COOLED MODELS

Instruction 9

⚠ WARNING	⚠ AVERTISSEMENT
<p>NEVER SIT IN CARGO AREA.</p> <p>Exceeding maximum cargo load may affect steering control and braking ability.</p> <p>MAXIMUM cargo load : XX Kg / XX Lbs.</p>	<p>NE JAMAIS S'ASSEoir À LA PLACE DU CARGO.</p> <p>Excéder le poids maximal du cargo peut affecter le contrôle de la direction et la capacité de freinage.</p> <p>Charge MAXIMALE cargo : XX Kg / XX Lbs.</p>

mno2007-002-002

Instruction 10

⚠ WARNING	
<p>NEVER STAND BEHIND or near a rotating track.</p> <p>Only spin track at lowest possible speed whenever off the ground.</p> <p>Broken track or debris could be projected with great force which could sever legs or cause other serious injuries.</p>	
⚠ AVERTISSEMENT	
<p>NE JAMAIS SE TENIR DERRIÈRE ou près d'une chenille qui tourne.</p> <p>Faire tourner la chenille seulement à la vitesse la plus basse possible lorsque soulevée de terre.</p> <p>Une chenille brisée ou des débris pourraient être projetés avec grande puissance pouvant sectionner une jambe ou causer d'autres blessures sérieuses.</p>	<p>516002673</p>

Instruction 11

⚠ WARNING	⚠ AVERTISSEMENT
<p>This vehicle is designed for one (1) operator and as many passengers as there are seats with air bags or handgrips installed on the vehicle conforming to SDC standards.</p> <p>When riding with a passenger:</p> <ul style="list-style-type: none"> Straining ability and steering control are reduced. Decrease speed and allow extra space to manoeuvre. Adjust suspensions according to weight. <p>REMEMBER: YOU ARE RESPONSIBLE FOR THE SAFETY OF YOUR PASSENGER!</p>	<p>Ce véhicule a été conçu pour un (1) conducteur et autant de passagers qu'il y a de sièges avec courroies ou poignées installés sur le véhicule et répondant à la norme SDC.</p> <p>Lors de la conduite avec passager :</p> <ul style="list-style-type: none"> La capacité de freinage et la direction sont réduites. Réduisez votre vitesse et prévoyez plus d'espace pour manœuvrer. Ajustez les suspensions selon la poids. <p>N'OUBLIEZ PAS : VOUS ÊTES RESPONSABLE DE LA SÉCURITÉ DE VOTRE PASSAGER!</p>

A00A5VA

Instruction 12

⚠ WARNING	⚠ AVERTISSEMENT
<p>ALL DRIVERS AND PASSENGERS MUST READ THE FOLLOWING:</p> <p>BE ON THE LONGCOURT for the LONGCOURT.</p> <p>Always identify:</p> <ul style="list-style-type: none"> Seat correctly for peak, subjects, conditions and opening windows. Adjust PWS for your weight. Check your seatbelt when off trail. <p>ALWAYS wear an DOT approved HELMET and fitting appropriate for snowmobiling.</p> <p>NEVER use other containers than the approved ones for passengers.</p>	<p>TOUJOURS porter un CASQUE approuvé DOT et des vêtements appropriés à la motoneige.</p> <p>NE JAMAIS utiliser un conteneur autre que l'appropris pour les passagers.</p>

A00A5SA

Instruction 13

AVERTISSEMENT

Lisez et comprenez toutes les étiquettes d'avertissements et le guide du conducteur avant l'utilisation.

Si le guide est introuvable, demandez-en un nouveau à votre concessionnaire.

Familiarisez-vous avec votre motoneige.

Les motoneiges imparfaitement réglées peuvent sous-estimer les risques et être sujettes aux comportements spécifiques de la motoneige et des conditions du terrain. Conduisez lentement, environnements.

La vitesse excessive et la conduite irresponsable peuvent causer la mort ! TOUJOURS adapter votre vitesse selon les conditions de neige et les circonstances environnementales.

Le contrôle de la direction et le freinage peuvent être réduits sur la neige compacte. Faites le à vos risques. Réduisez votre vitesse et laissez plus d'espace pour tourner ou freiner.

Respectez les lois sur l'âge minimal du conducteur.

Le fabricant recommande que le conducteur soit âgé d'au moins 16 ans.

516002853

WARNING

Read and understand all warning labels and operator's guide before operation. If guide is missing, ask your dealer for a new one.

Get familiar with your snowmobile. Impaired riders may overlook risks and be surprised by snowmobile's specific behavior and terrain conditions.

Excessive speed and reckless driving can kill! ALWAYS adjust your speed according to snow conditions and circumstances.

Steering control and braking ability may be reduced on hard-packed snow, ice or roads. Reduce speed & allow more space to stop or turn.

Respect laws on minimum operator age. Manufacturer recommends a minimum operating age of 16 years old.

A00A8UA

Instruction 16

VEHICLE ENGINE DESCRIPTION:

XXXXX

EPA CERTIFIED

NER (NORMALIZED EMISSION RATE) =

ON A 0 TO 10 SCALE, 0 BEING THE CLEANEST

***NOT TO BE REMOVED PRIOR TO SALE**

704901107

vmo2006-005-009_en

HANG TAG — NOT SHOWN

Instruction 14

TO REMOVE PASSENGER SEAT:

- Pull the driver seat latch handle and lift the seat fully open.
- Push passenger seat forward against stoppers and pull the seat out.

TO REINSTALL PASSENGER SEAT:

- Put passenger seat in place with the J-hooks lined-up in their respective slots.
- Push the seat backwards to engage the J-hooks locking it securely in place.
- Close the driver seat.

WARNING

To avoid the risk of the passenger falling off:

- Before riding, make sure the passenger seat is locked in place securely and that the driver seat latch is engaged properly.

POUR ENLEVER LE SIÈGE PASSAGER:

- Soulever la manette du loquet de siège conducteur et pivoter le siège en position ouverte.
- Pousser le siège passager vers l'avant contre les butées et soulever le siège.

POUR RÉINSTALLER LE SIÈGE PASSAGER:

- Déposer le siège passager en place en alignant les crochets en J dans leurs rainures respectives.
- Pousser le siège vers l'arrière pour engager les crochets en J et ainsi barrer le siège en place.
- Fermer le siège conducteur.

AVERTISSEMENT

Pour éviter le risque de chute du passager:

- Avant la conduite, assurez-vous que le siège passager soit bien barré en place et que le loquet du siège conducteur soit bien engagé.

516002853

Instruction 15

EMISSION CONTROL INFORMATION

THIS VEHICLE IS CERTIFIED TO OPERATE ON UNLEADED GASOLINE AND MEETS [XXXX] U.S. EPA REGULATIONS FOR SNOWMOBILE SI ENGINES.

ENGINE FAMILY	XXXX	FAMILLE DE MOTEUR
		LIMITE DES ÉMISSIONS
		DE LA FAMILLE
ENGINE DISPLACEMENT	XXXX	CYLINDRÉE
EXHAUST EMISSION CONTROL SYSTEM	XXXX	SYSTÈME DE CONTRÔLE DES ÉMISSIONS

RENSEIGNEMENTS SUR LE DISPOSITIF ANTIPOLLUTION

CE VÉHICULE EST CERTIFIÉ POUR FONCTIONNER À L'ESSENCE SANS PLOMB ET IL RÉPOND AUX NORMES [XXXX] DE L'EPA DES É.-U. POUR LES MOTONEIGES À MOTEUR SI.

SEE OPERATOR'S GUIDE FOR MAINTENANCE SPECIFICATIONS
VOIR GUIDE DU CONDUCTEUR POUR LES SPÉCIFICATIONS D'ENTRETIEN

BOMBARDIER RECREATIONAL PRODUCTS INC.

mmo2007-009-070

TYPICAL

SAFETY INFORMATION

25

ENVIRONMENT INFORMATION

GENERAL

Wildlife compliments your snowmobiling day. Snowmobile tracks provide firm ground over which animals can travel from area to area. Do not violate this privilege by chasing or harassing wildlife. Fatigue and exhaustion can lead to animal's death. Avoid areas posted for the protection or feeding of wildlife.

If you happen to be fortunate enough to see an animal, stop your snowmobile and observe quietly.

The guidelines that we support are not designed to limit your snowmobiling fun, but to preserve the beautiful freedom that you can experience only on a snowmobile! These guidelines will keep snowmobilers healthy, happy and able to introduce others to what they know and enjoy about their favorite winter pastime. So, the next time you hit the trails on a cool, crisp and clear winter day, we ask you to remember that you are paving the way for the future of our sport. Help us lead it down the right path! From all of us at BRP, thank you for doing your share.

There is nothing more exhilarating than snowmobiling. Venturing onto snowmobile trails that criss-cross the wild areas of the U.S. and Canada is an exciting and healthy winter sport. However, as the number of people using these recreational parks increases, so does the potential for damage to the environment. Abuse of land, facilities and resources inevitably leads to restrictions and closures of both private and public land.

In essence, the greatest threat to our sport, is all around us. Which leaves us with one logical choice. When we snowmobile, we must always ride responsibly.

The vast majority respect the law and the environment. Each of us must set an example for those who are new to the sport, young and old alike.

It is in every one's best interest to tread lightly into our recreational areas. Because, in the long run, to protect the sport we must preserve the environment.

Recognizing the importance of this issue and the need for snowmobilers to do their share in preserving areas that make it possible to enjoy our sport, BRP has developed the "Light Treading is Smart Sledding" campaign for snowmobilers.

Light Treading refers to more than the thread of our tracks. It's a statement of concern, respect and willingness to take the lead and take action. It applies to the environment in general, its proper care and maintenance, its natural inhabitants and all enthusiasts and the public at large who enjoy the great outdoors. With this theme, we invite all snowmobilers to remember that respecting the environment is not only critical to the future of our industry but to future generations.

Light Treading in no way suggests you should curb your appetite for snowmobiling fun! It simply means tread with respect!

JUST WHAT IS LIGHT TREADING?

The fundamental objective of Light Treading is one of respect for where and how you ride a snowmobile. You're a light treader when you follow the principles below.

Become informed. Obtain maps, regulations and other information from the Forest Service or from other public land agencies. Learn the rules and follow them and that goes for speed limits, too!

Avoid running over young trees, shrubs, and grasses and don't cut wood. On flatlands or areas where trail riding is popular, it's important to ride only where authorized. Remember, there is a link between protecting your environment and your own safety.

Respect wildlife and be particularly sensitive of animals that are rearing young or suffering from food shortage. Stress can sap scarce energy reserves. Refrain from riding in areas where only animals are intended to tread!

Obey gate closures and regulatory signs and remember, light treaders don't litter!

Stay out of wilderness areas. They're closed to all vehicles. Know where the boundaries are.

Obtain permission to travel across private land. Respect the rights of landowners and other people's privacy. Remember, snowmobile technology has lowered the noise factor considerably, but you still shouldn't rev your engines where quiet "is the order of the day".

WHY IS LIGHT TREADING SMART

Snowmobilers know all too well the efforts that have been made throughout the sport's history to enjoy access to areas where people can snowmobile safely and responsibly. This effort continues today, as strong as ever.

Respecting the areas where we ride... wherever they may be... is the only way to ensure their future enjoyment. That's one major reason why we know you'll agree that Light Treading Is Smart Sledding! And there are more.

Enjoying the opportunity to see winter and all its natural majestic wonders, is an experience cherished by snowmobilers. Light Treading will preserve this opportunity and will make it possible for us to expose others to the beauty of winter and the unique thrill of our sport! Light Treading will help our sport to grow!

Finally, Light Treading is the sign of a smart snowmobiler. You don't have to leave big tracks or careen through a virgin forest to show you can ride. So whether you're driving a high performance SKI-DOO, a sporty MX Z snowmobile or any other make or model, show you know what you're doing. Show you know how to send snow flying and make tracks with a light touch!

VEHICLE INFORMATION

HOW TO IDENTIFY YOUR SNOWMOBILE

Vehicle Description Decal

Vehicle description decal is located on right hand side of tunnel.

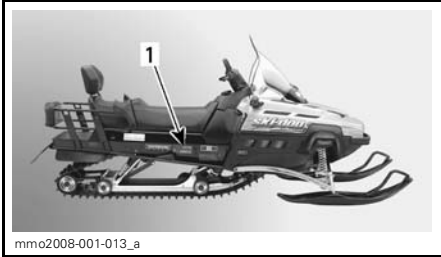

TYPICAL

1. Vehicle description decal



VEHICLE DESCRIPTION DECAL

1. Manufacturer name
2. Manufacturing date
3. Vehicle identification number (VIN)

Serial Numbers

The main components of your snowmobile (engine and frame) are identified by different serial numbers. It may sometimes become necessary to locate these numbers for warranty purposes or to trace your snowmobile in the event of loss. These numbers are required by the authorized SKI-DOO dealer to complete warranty claims properly. No warranty will be allowed by BRP if the engine serial number or vehicle identification number (VIN) is removed or mutilated in any way. We strongly recommend that you take note of all the serial numbers on your snowmobile and supply them to your insurance company.

Vehicle Identification Number (VIN) Location

VIN is scribed on vehicle description decal. See above. It is also embossed on tunnel near vehicle description decal.

Model Number Location

Model number is part of vehicle identification number (VIN).

Typical VIN Description

2	BPS	BX5A	9	Y	1	000001
---	-----	------	---	---	---	--------

Model number: BX5A9Y1000001

Serial number: 000001

Model year: y = 2000
1 = 2001
2 = 2002
etc.

Engine Serial Number Location

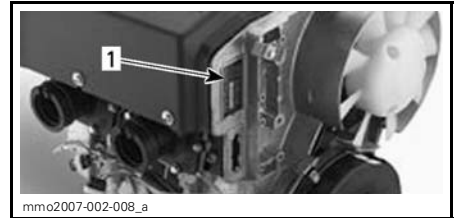

FAN COOLED — 550F ENGINE TYPE

1. Engine serial number



LIQUID COOLED — 600/600 HO SDI ENGINE TYPE

1. Engine serial number

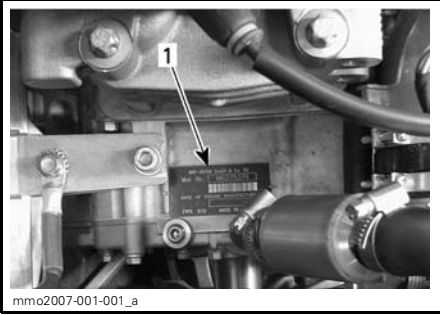

mmo2007-001-001_a

V800 ENGINE TYPE
1. Engine serial number

CONTROLS/INSTRUMENTS/EQUIPMENT

NOTE: Some controls/instruments/equipment do not apply or are optional on some models. In these cases their reference numbers are deliberately missing in the illustrations.

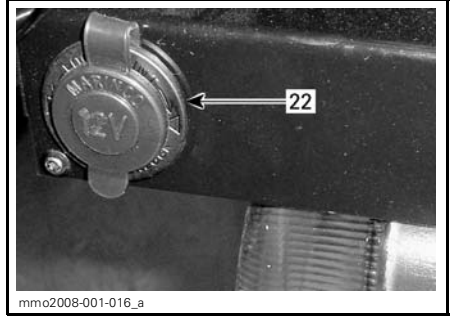
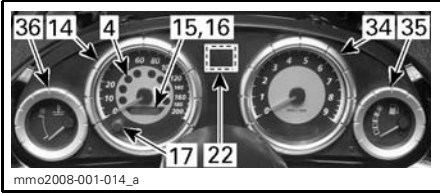

SKANDIC™ SWT V800 ONLY — REAR RACK
22. Electric power outlet

TYPICAL

- 4. Pilot lamps
- 14. Speedometer
- 15. Odometer
- 16. Display
- 17. Mode button
- 22. Electric power outlet
- 34. Tachometer
- 35. Electric fuel level gauge
- 36. Temperature gauge

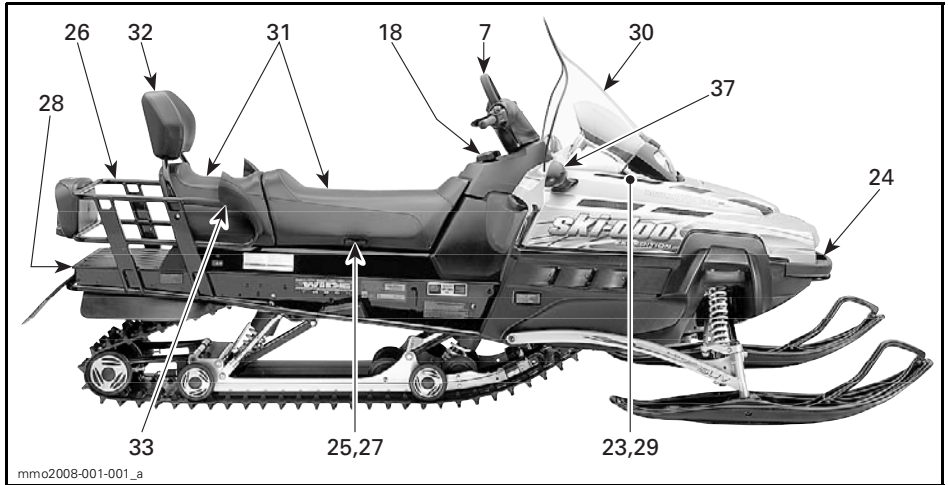

TYPICAL

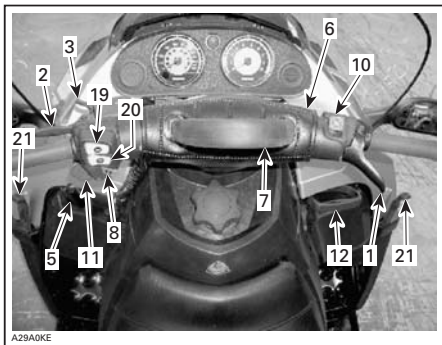

A29A0KE

TYPICAL

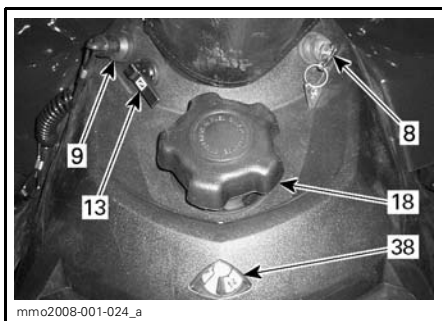

mimo2008-001-024_a

TYPICAL

1) Throttle Lever

Located on the right hand side of handlebar and designed to be thumb activated. When squeezed, it increases the engine speed and engages the transmission. When released, engine speed returns automatically to idle.

WARNING

Test the throttle lever operation each time before starting the engine. The lever must return to its original position once released. Otherwise, do not start engine.

2) Brake Lever

Located on the left hand side of handlebar. When squeezed, the brake is applied. When released, it automatically returns to its original position. Braking effect is proportional to the pressure applied on the lever and to the type of terrain and its snow coverage.

3) Parking Brake Lever

Located on left hand side of handlebar. Parking brake should be used whenever snowmobile is parked.

WARNING

Make sure parking brake is fully disengaged before operating the snowmobile. When you ride the vehicle, brake pads that are caused to drag by a continuous pressure on the lever may cause damage to the brake system and cause loss of braking capacity and/or fire.

To Engage Mechanism

Squeeze brake lever and maintain while pulling locking lever with a finger. When brake lever is held at half-way the parking brake should be fully applied.

To Release Mechanism

Squeeze brake lever. Locking lever will automatically return to its original position. Always release parking brake before riding.

4) Pilot Lamps

Injection Oil Level/Engine Oil Pressure

2-Stroke Models



Lights up when injection oil level is low (with engine running). Check oil level and replenish as soon as possible.

4-Stroke Models



This pilot lamp will glow up when engine oil pressure is too low. Stop vehicle in a safe place then, check oil level and replenish as described in *ENGINE OIL LEVEL*.

Restart engine, oil pilot lamp must turn off after few seconds. If oil pilot lamp still glows up, stop engine and have lubrication system inspected by an authorized SKI-DOO dealer.

DESS Status

Liquid Cooled Models



This lamp will light up to confirm DESS status. Refer to previous paragraphs for description.

High Beam

All Models



Lights when headlamp is on HIGH beam.

Engine Overheat Warning

Liquid Cooled Models



If this lamp glows, reduce snowmobile speed and run snowmobile in loose snow or stop engine immediately.

Low Battery Voltage

600 HO SDI and V800 Models



This lamp will light up to indicate a low battery voltage condition. See an authorized SKI-DOO dealer as soon as possible.

Engine Management System (EMS)

600 HO SDI and V800 Models



This lamp will light up to indicate a trouble. Refer to *TROUBLESHOOTING* for trouble code meaning and remedy.

5) Gear Shift Lever

These models are equipped with a mechanical reverse controlled by a 4-position gear shift lever.



A29D2JA

TYPICAL

Shifting Procedure

WARNING

The reverse speed of these snowmobiles is not limited. Always proceed with caution as fast reverse could result in loss of vehicle stability and control. Come to complete stop before selecting reverse gear. Wait until the reverse alarm sounds before operating throttle to proceed in reverse. Always remain seated and apply the brake before shifting. Ensure the path behind is clear of obstacles or bystanders before proceeding.

CAUTION: Upshift only when engine is idling and speed is below 20 km/h (12 MPH).

With snowmobile completely stopped and engine at idle, move lever to engage in desired gear.

Maximum speed in first gear is 60 km/h (37 MPH).

Do not force lever. If unable to shift, apply throttle to move snowmobile, stop vehicle, then try again.

6) Handlebar

The handlebar allows the steering of the snowmobile. As the handlebar is rotated to right or left, the skis are turned right or left to steer the snowmobile.

WARNING

Fast reverse while turning, could result in loss of stability and control.

Handlebar height is adjustable. See an authorized SKI-DOO dealer.

7) Holding Strap

Holding strap provides a grip for driver when side-hilling.

WARNING

This strap is not for towing, lifting or other purpose than temporary use as a grab handle during side-hilling. Always keep at least one hand on the handlebar.

8) Ignition Switch/Start Button

Ignition Switch

Fan Cooled Models

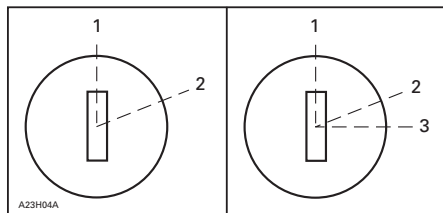

MANUAL START/ELECTRIC START

1. OFF
2. ON
3. START

Manual Starting

To start the engine, first turn the key to ON position, then pull rewind starter handle. To stop the engine, turn the key to OFF position. See illustration above.

Electric Starting

To start engine, turn key to START position and hold until engine has started. See illustration above.

CAUTION: Do not engage electric starter for more than 10 seconds at a time. A rest period should be observed between the cranking cycles to allow electric starter to cool down. Using electric starter when engine has started could damage electric starter mechanism.

Release the key as soon as the engine starts. Key returns to ON position as soon as it is released.

If the engine does not start on the first try, turn the key back to OFF and wait a few seconds before restarting. To stop engine, turn the key to OFF.

NOTE: Engine may be manually started with rewind starter if necessary.

If starter does not operate, check starting system fuse condition. Refer to *STARTING SYSTEM AND ELECTRIC POWER OUTLET FUSE*.

Start Button

Liquid Cooled Models

To start engine, push START button and hold until engine has started.

CAUTION: Do not hold START button more than 10 seconds at a time. A rest period should be observed between the cranking cycles to allow starter to cool down. Holding START button when engine has started could damage starter mechanism.

Release START button immediately when engine has started.

If engine does not start on first try, wait a few seconds then repeat procedure.

V800 Model

NOTE: If engine does not start after the second try, wait until all lights are shutdown then repeat procedure.

All Models

To stop engine, turn off engine cut-out switch or pull off tether cord cap (DESS key).

If starter does not operate, check starting system fuse condition. Refer to *STARTING SYSTEM AND ELECTRIC POWER OUTLET FUSE*.

All Models except V800

NOTE: Engine may be manually started with rewind starter if necessary.

9) Tether Cut-Out Switch

General

When the tether cord cap (DESS key) is removed, it shuts the engine off preventing snowmobile to runaway if the operator falls off the vehicle accidentally.

WARNING

Always remove ignition key or tether cord cap (DESS key) when vehicle is not in operation in order to prevent accidental engine starting, to avoid unauthorized use by children or others or theft.

Operation

Attach tether cord eyelet to clothing, then snap cap (DESS key) over post before starting engine.

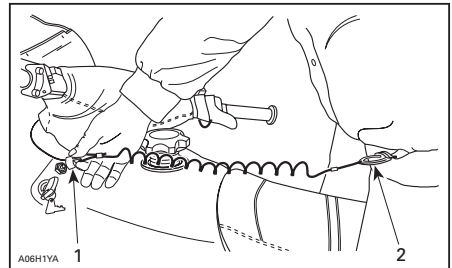

TYPICAL

1. Snap over post
2. Attach to clothing eyelet

If emergency engine shut off is required, pull tether cord cap (DESS key) from post completely.

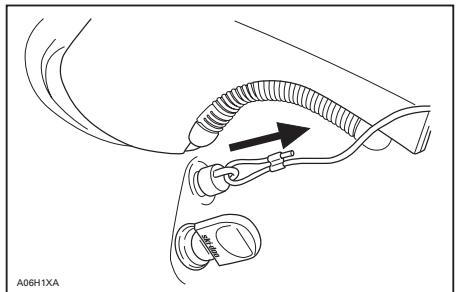

TYPICAL

DESS (Digitally Encoded Security System) Key/ Cut-Out Switch

Liquid Cooled Models

On these models, the tether cord cap (DESS key) is digitally encoded to provide you and your snowmobile with the equivalent security of a conventional lock key and it shuts off the engine preventing snowmobile to run-away if the operator falls off the vehicle accidentally.

The DESS key provided with your snowmobile contains an electronic chip which features a unique permanently memorized digital code. Your authorized SKI-DOO dealer programs this key in the ECM (Engine Control Module) of your snowmobile to allow engine operation above 3000 RPM if and only if this unique code has been read after engine starting.

If another DESS key is installed, the engine will start but will not reach drive pulley engagement speed to move vehicle.

Make sure the DESS key is free of dirt or snow.

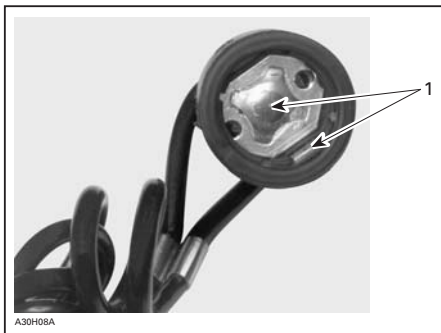

DESS KEY
1. Free of dirt or snow

Additional DESS Keys

The ECM of your snowmobile can be programmed by your authorized SKI-DOO dealer to accept 8 different keys.

We recommend the purchase of additional keys from your authorized SKI-DOO dealer. If you have more than one DESS equipped SKI-DOO snowmobile, each can be programmed by your authorized SKI-DOO dealer to accept the other vehicles keys.

DESS Pilot Lamp Codes

NOTE: If any code still occurs, contact an authorized SKI-DOO dealer.

WARNING SIGNALS		DESCRIPTION	
BEEPER	DESS PILOT LAMP		
2 shorts	Blink	Good key	
1 short per 1.5 second/ repetitive	Blink	Unable to read key (bad connection)	Make sure the (DESS key) is free of dirt or snow. Reinstall key and restart engine. Vehicle can not be driven.
3 shorts per second/ repetitive	Blink	Invalid key or key not programmed	Use the proper key for this vehicle or have the key programmed. Vehicle can not be driven.

10) Engine Cut-Out Switch

To stop the engine in an emergency, push the button to the lower position (OFF) and simultaneously apply the brake. To restart, button must be at the upper position (ON).

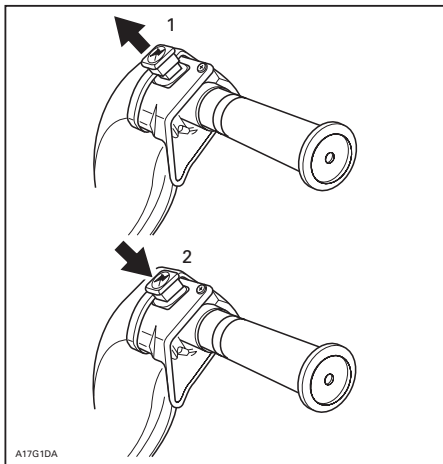

1. ON
2. OFF

All operators of the snowmobile should familiarize themselves with the function of this device by using it several times on first outing and whenever stopping the engine there-after. This engine cut-out procedure will become a reflex and will prepare operators for emergency situations requiring its use.

WARNING

If the switch has been used in an emergency caused by a suspected malfunction, the source of the malfunction should be determined and corrected before restarting engine. See an authorized SKI-DOO dealer for servicing.

11) Headlamp Dimmer Switch

Located on left hand side of handlebar, allows selection of headlamp beam. Note that lights are automatically ON whenever the engine is running.

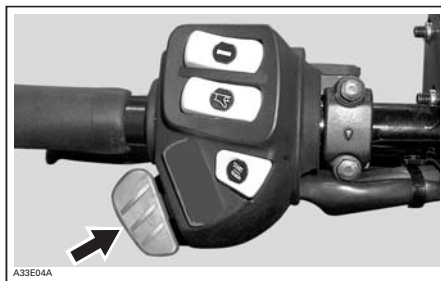

12) Rewind Starter Handle

All Models except V800

Auto-rewind type located on right hand side of snowmobile. To engage mechanism, pull handle slowly until a resistance is felt, then pull vigorously. Slowly release handle.

13) Choke Lever

550F and 600 Models

See proper usage instructions in *STARTING THE ENGINE* in *OPERATING INSTRUCTIONS* section.

This device features a 3-position lever to facilitate cold start.

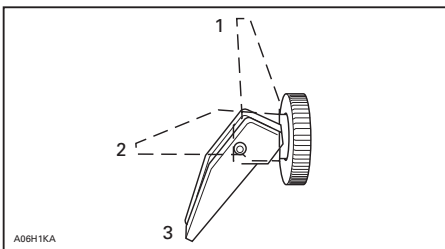

1. OFF
2. Position 2
3. Position 3

Initial Cold Starting

NOTE: Do not operate the throttle lever with the choke lever on.

Move the choke lever to position 3 and start the engine. As soon as the engine starts, move the lever to position 2. After a few seconds (10 seconds maximum) move the choke lever to OFF.

NOTE: In severe cold weather, colder than - 20°C (- 4°F) you may need to flip choke lever from position 1 (OFF) to position 2 a couple of times once engine is started.

Warm Engine Starting

Start the engine without any choke. If the engine will not start after two pulls of the rope or two 5 second attempts with the electric starter move choke lever to position 2. Start the engine without activating the throttle lever. As soon as the engine starts move the choke lever to position 1 (OFF).

14) Speedometer

Direct-reading dial indicates the speed of the snowmobile in km/h or MPH.

These models are equipped with an electronic speedometer. It may show speed in km/h or MPH.

At vehicle speed of 90 km/h (55 MPH) and more, the multifunction display will show speed only instead of the selected mode.

Unit Selection (MPH vs km/h)

The speedometer is factory preset in miles but it is possible to change it to kilometer reading, refer to the following procedure or contact an authorized SKI-DOO dealer.

NOTE: Speedometer, odometer and trip meter will have their units (kilometer or miles) changed all together.

Stop engine and open engine compartment. Cut locking ties. Plug connectors together to change units from miles to kilometers.

Unplug to return to miles reading. Fasten connector to harness with locking ties.

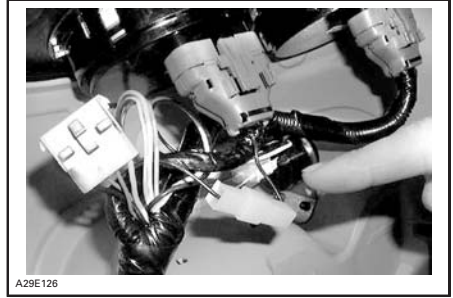

CONNECTORS LOCATION

15) Odometer

Odometer records the total distance travelled and displays it either in miles or kilometers.

NOTE: At vehicle speed of 90 km/h (55 MPH) and more the mode LCD screen will show speed only instead of the selected mode.

16) Trip Meter/Display

Trip Meter

Records distance travelled since it has been reset. Distance travelled is displayed either in miles or kilometers.

Refer to *UNIT SELECTION (MPH VS KM/H)* for changing units.

Display

NOTE: At vehicle speed of 90 km/h (55 MPH) and more the mode LCD screen will show speed only instead of the selected mode.

Resetable Hour Meter

Records engine running time in hours and minutes since it has been reset.

Push and hold mode button for 2 seconds to reset the hourmeter.

Multifunction Display Code

If your speedometer shows **SCALE** in the multifunction display, it means that the display selector button is stuck in the down position or depressed when the electrical system was activated.

17) Mode Button

Depress mode button to change display. Each time engine is started, display shows odometer. From that point depressing mode button will change display for the trip meter.

Depressing mode button again will change display for the resettable hourmeter. Push mode button again to return to odometer.

Push and hold mode button for 2 seconds to reset the tripmeter or the resettable hourmeter depending on the one displayed.

18) Fuel Tank Cap

Unscrew to fill up tank, then fully tighten.

WARNING

Always stop the engine before refueling. Fuel is flammable and explosive under certain conditions. Always work in a well ventilated area. Do not smoke or allow open flames or sparks in the vicinity. Open cap slowly. If a differential pressure condition is noticed (whistling sound heard when loosening fuel tank cap) have vehicle inspected and/or repaired before further operation. Do not overfill or top off the fuel tank before placing the vehicle in a warm area. As temperature increases, fuel expands and might overflow. Always wipe off any fuel spillage from the vehicle. Periodically verify fuel system.

NOTE: Do not sit or lean on seat when fuel tank cap is not properly installed.

19) Heated Grip Switch

Three-position toggle switch. Select the desired position to keep your hands at a comfortable temperature.

20) Heated Throttle Lever Switch

Three-position toggle switch. Select the desired position to keep your right thumb at a comfortable temperature.

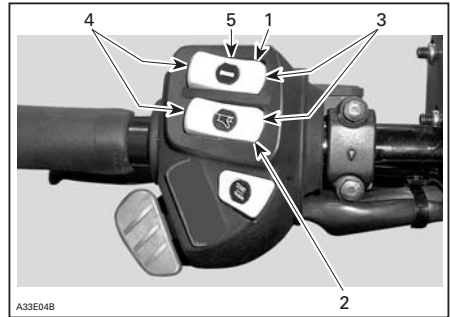

1. Heated grip switch
2. Heated throttle lever switch
3. Hot
4. Warm
5. Off

21) Hood Latches

Stretch and unhook the latches to unlock the hood from its anchors.

Always lift hood gently until stopped by retaining device.

Close hood slowly, then hook up latches.

22) Electric Power Outlet

A 12-volt electric appliance may be connected to that jack connector. Electric current is supplied when ever engine is running. See *FUSES* section for electric power outlet fuse location.

MODELS	MAXIMUM OUTPUT CURRENT	LOCATION
SWT V800	20 amperes	Rear rack
	5 amperes	Dashboard
All others	5 amperes	Dashboard



A29104A

TYPICAL — ELECTRIC POWER OUTLET

SWT V800 Model Only

With the engine running, use the toggle switch mounted on the multi-switch housing to supply current to the rear rack power outlet.

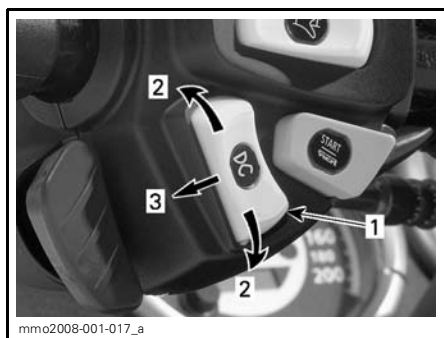

mmo2008-001-017_a

MULTI-SWITCH HOUSING

1. Rear power outlet switch
2. Upper/Lower ON position
3. Middle OFF position

23) Fuses

Fuse Removal/Inspection

Check fuse condition and replace it if necessary.

To remove fuse from holder, pull fuse out. Check if filament is melted.

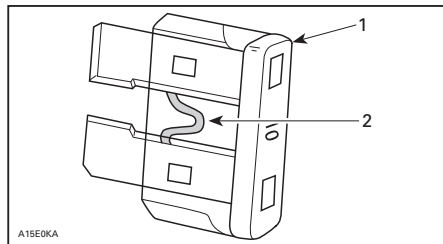

A15E0KA

1. Fuse
2. Check if melted

CAUTION: Do not use a higher rated fuse as this can cause severe damage to electrical components and/or be a potential fire hazard.

WARNING

If fuse has burnt out, source of malfunction should be determined and corrected before restarting. See an authorized SKI-DOO dealer for servicing.

Description/Location

550F Model

FUSE	DESCRIPTION	LOCATION
30 A	Ground protection (includes electric power outlet)	Engine compartment

Ground Protection

CAUTION: This fuse should always be disconnected before doing any maintenance under the hood. This is to prevent any unexpected electrical activation.



ENGINE COMPARTMENT — UNDERNEATH CONSOLE

1. Fuse holder

600 Model

FUSE	DESCRIPTION	LOCATION
20 A	Load	F1
15 A	Heaters	F2
15 A	Instruments/rear light	F3
5 A	Start	F4
30 A	Engine	F5
5 A	Relays	F6
15 A	Lighting (headlamp)	F7

Fuse box
(engine compartment)

600 HO SDI Model

FUSE	DESCRIPTION	LOCATION
30 A	Load	F1
5 A	CAPS	F2
15 A	Instruments	F3
7.5 A	MPEM/fuel pump	F4
5 A	PTO cylinder (injectors)	F5
5 A	MAG cylinder (injectors)	F6
30 A	Load	F7
5 A	Relay/start button	F8
20 A	Lighting (headlamp)	F11
20 A	Heaters	F12

Fuse box
(engine compartment)

V800 Model

FUSE	DESCRIPTION	LOCATION
30 A	Engine	F1
1 A	CAPS	F2
5 A	Instrumentation	F3
5 A	MPEM/fuel pump	F4
15 A	PTO cylinder	F5
15 A	MAG cylinder	F6
30 A	Load	F7
5 A	Relay/start button	F8
20 A	Rear power outlet/horn (Skandic SWT)	F9
5 A	Alternator (Expedition™ TUV)	F9
15 A	Cooler	F10
20 A	Lighting (headlamp)	F11
20 A	Secondary load	F12

Fuse box
(engine compartment)

Electric Fuel Level Gauge

Expedition TUV

See an authorized SKI-DOO dealer for fuse replacement.

Fuse Box

To open fuse box push on cover tab and tilt cover. A fuse description decal is inside the cover.

600 Model

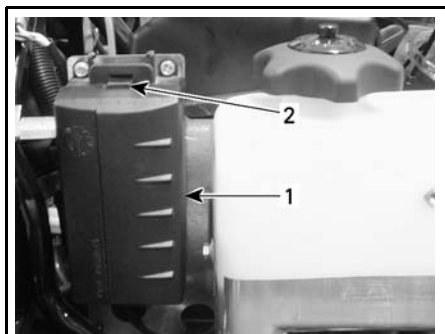

1. Fuse box
2. Cover tab

600 HO SDI Model

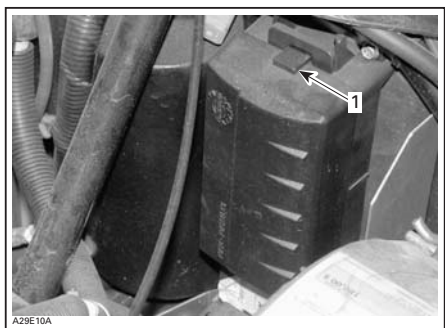

- FUSE BOX**
1. Cover tab

V800 Model

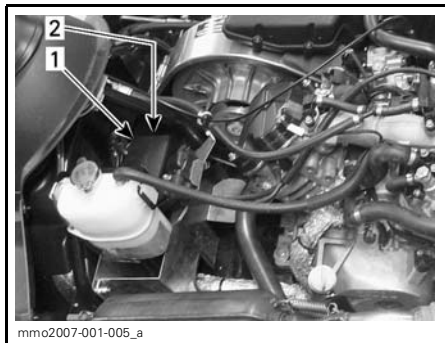

1. Fuse box
2. Cover tab

24) Front Grab Handles/ Front Bumper

To be used whenever front of snowmobile requires manual lifting.

⚠ WARNING

Do not attempt to lift the vehicle by hand alone. Use appropriate lifting device or have assistance to share lifting stress in order to avoid risk of strain injuries.

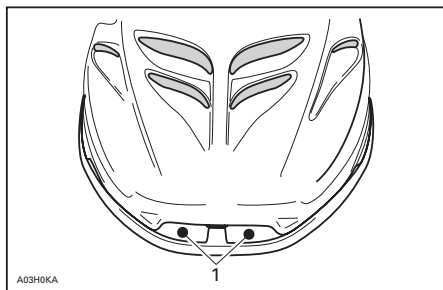

TYPICAL

1. Front grab handles

CAUTION: Do not use skis to pull or lift snowmobile.

V800 Model

CAUTION: Do not lift snowmobile by the front bumper.

25) Storage Compartment

⚠ WARNING

All storage compartments must be properly latched and they must not contain any heavy or breakable objects.

A storage compartment is provided under seat. To open storage compartment, lift seat latch, then tip seat over.

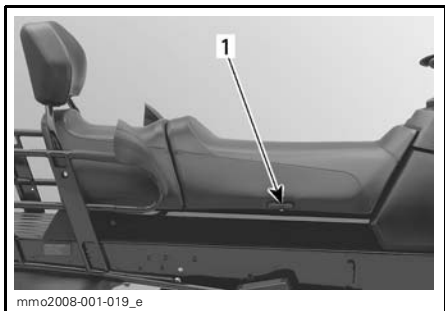

TYPICAL

1. Lift seat latch

26) Rear Rack

WARNING

All objects in rear rack must be properly latched. Do not carry any breakable objects. Excessive weight in rack may reduce steering ability.

CAUTION: Always readjust suspension according to the load. The capacity of this rack is limited. Ride at very low speed when loaded. Avoid speed over bumps.

27) Tool Kit

A tool kit containing tools for basic maintenance is supplied with the vehicle under seat.

28) Hitch

The hitch can be used to pull most equipment. Use a rigid tow bar.

29) Shields and Guards

WARNING

Never operate engine without belt guard securely installed or, with hood or access/side panels opened or removed.

Your snowmobile is provided with a number of shields and guards. Leave these in place on your vehicle as they are designed to keep clothing and hands out of moving parts and away from hot components. Never attempt to make adjustments to any moving part while the engine is running.

30) Windshield

Windshield provides operator comfort, as well as protection by deflecting wind and snow away from the operator.

31) Modular Seat

This snowmobile can be converted into a snowmobile with one (1) seat only instead of two (2). This could be useful if you want to increase the cargo area.

If necessary, backrest can also be removed to increase the cargo area. Refer to *BACKREST*.

WARNING

Never ride with a passenger without the backrest properly installed.

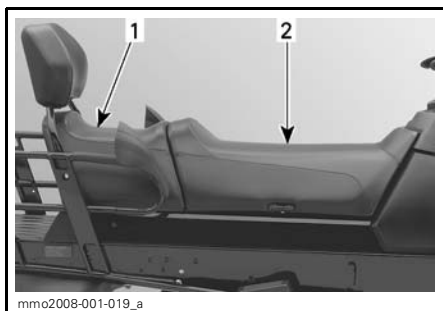

TYPICAL

1. Passenger seat (removable)

2. Driver seat

To remove the passenger seat, lift seat latch, then tip driver seat over.

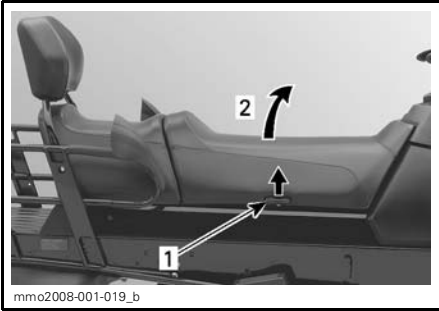

TYPICAL

1. Seat latch
2. Tip driver seat over

Slide the passenger seat forward, then lift to remove.

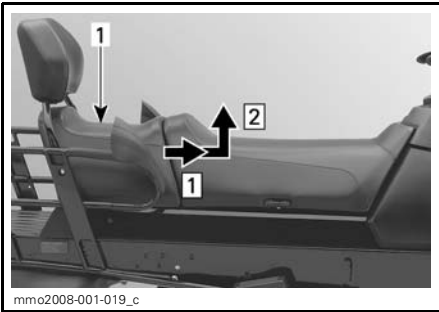

TYPICAL

- Step 1: Slide seat forward
 Step 2: Lift seat to remove
1. Passenger seat

CAUTION: Take care to store the passenger seat properly to avoid any damages.

⚠ WARNING

NEVER use the space left by removing the passenger seat to sit a passenger. The passenger could hurt his back or suffer other serious injuries due to his seating position.

⚠ WARNING

All objects in rear rack must be properly latched. Do not carry any breakable objects. Excessive weight in rack may reduce steering ability.

Installation is the reverse of removal procedure. Pay attention to the following.

⚠ WARNING

Make sure that the passenger seat is locked securely in place before using the snowmobile.

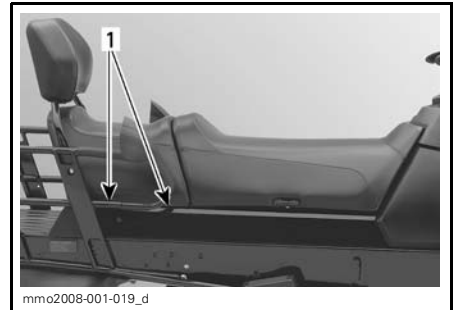

TYPICAL

1. Passenger seat hooks

32) Backrest

⚠ WARNING

Never ride with a passenger without the backrest properly installed.

Skandic SWT Only

To remove backrest, remove retaining hardware on both sides.

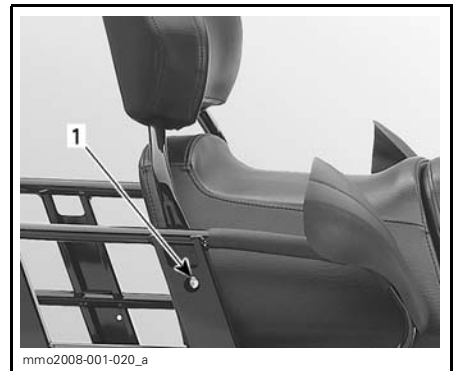

TYPICAL

1. Retaining hardware

All Other Models

To remove backrest, remove wing screw on both sides.



1. Wing screw

All Models

CAUTION: Take care to store backrest properly to avoid any damages.

33) Rear Grab Handles/ Heated Grips Switch

Expedition TUV

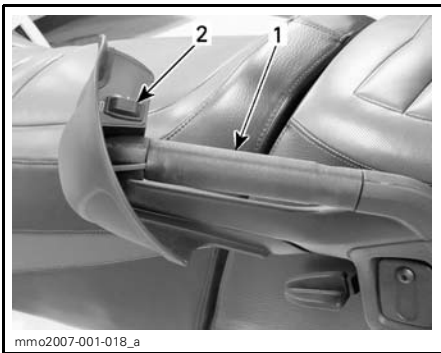

TYPICAL

1. Left side passenger grab handle
2. Heated grips switch

Rear Grab Handles

Rear grab handles provides a grip for the passenger.

Heated Grips Switch

Three-position switch. Select the desired position to keep rear passenger's hands at a comfortable temperature.

34) Tachometer

Direct-reading dial indicates the number of thousand of revolutions per minute (RPM) of the engine.



TYPICAL — MULTIPLY THE READING BY 1000

35) Electric Fuel Level Gauge

Expedition TUV

Dash-mounted gauge to facilitate fuel level reading. This gauge functions when engine is running.

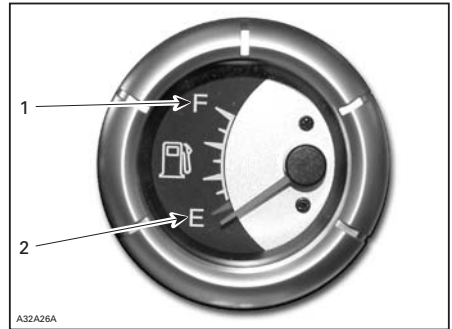

TYPICAL

1. Full
2. Empty

36) Temperature Gauge

Expedition TUV

The gauge indicates engine coolant temperature. The needle moves to the normal range as engine warms. Under all riding conditions, the needle should stay within this range. If needle moves into the overheat range, reduce snowmobile speed and run snowmobile in loose snow or stop engine immediately.

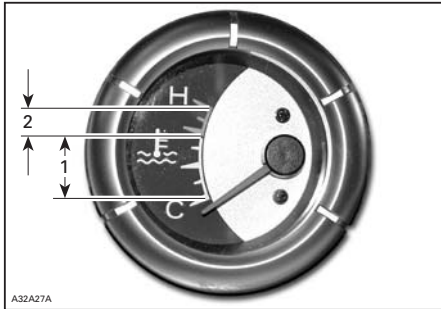

TYPICAL

- 1. Normal
- 2. Overheat

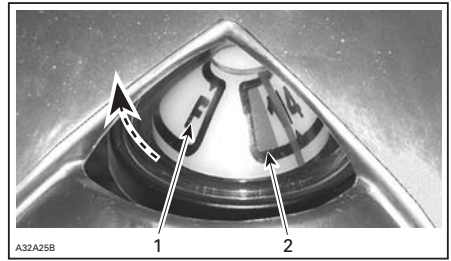

TYPICAL

- 1. Full
- 2. Empty

37) Adjustable Mirrors

Each mirror can be adjusted to suit driver's preference.

⚠ WARNING

Adjust with vehicle at rest in a safe place.

⚠ WARNING

Objects in mirror are closer than they appears.

38) Mechanical Fuel Level Gauge

All Models except Expedition TUV

Located at rear of fuel tank cap, the gauge facilitates fuel level reading.

RECOMMENDED FUEL AND OIL

Recommended Fuel

Use regular unleaded gasoline, available from most service stations or oxygenated fuel containing a maximum total of 10% of ethanol or methanol or both. The gasoline used must have the following recommended minimum octane number.

LOCATION	OCTANE NUMBER
Inside North America	(87 (RON + MON)/2) ⁽¹⁾
Outside North America	92 RON ⁽¹⁾

⁽¹⁾ This is the minimum octane number required, if not available, (91 (RON + MON)/2) or 95 RON (outside North America) can be used.

CAUTION: Never experiment with other fuels or fuel ratios. The use of unrecommended fuel can result in snowmobile performance deterioration and damage to critical parts in the fuel system and engine components. Do not mistake oil reservoir cap for fuel tank cap. Oil reservoir cap is identified OIL.

WARNING

Always stop the engine before refueling. Fuel is flammable and explosive under certain conditions. Always work in a well ventilated area. Do not smoke or allow open flames or sparks in the vicinity. Open cap slowly. If a differential pressure condition is noticed (whistling sound heard when loosening fuel tank cap) have vehicle inspected and/or repaired before further operation. Do not overfill or top off the fuel tank before placing the vehicle in a warm area. As temperature increases, fuel expands and might overflow. Always wipe off any fuel spillage from the vehicle. Periodically verify fuel system.

Fuel System Antifreeze

When using oxygenated fuel, additional gas line antifreeze or water absorbing additives are not required and should be not used.

When using non-oxygenated fuel, we highly recommend the use of isopropyl base gas line antifreeze in a proportion of 150 mL (5 U.S. oz) of gas line antifreeze added to 40 liters (10-1/2 U.S. gal) of gas.

This precaution is in order to reduce the risk of frost buildup in carburetors/throttle bodies which may lead, in certain cases, to high fuel consumption or severe damage to engine.

NOTE: Use only methyl hydrate free gas line antifreeze.

Recommended Oil

550F/600/600 HO SDI Engine Type

CAUTION: Use only injection oil that flows at - 40°C (- 40°F). Do not mismatch oil reservoir cap with fuel tank cap. Oil reservoir cap is identified OIL.

Oil is contained in the injection oil reservoir.

Use only two-stroke engine injection oil sold by authorized SKI-DOO dealers.

ENGINE TYPE	OIL TYPE
550F and 600	XP-S™ mineral injection oil ⁽²⁾
600 HO SDI ⁽¹⁾	XP-S 2-stroke synthetic blend

CAUTION: ⁽¹⁾ XP-S 2-stroke synthetic blend oil is specially formulated and tested for the severe requirements of this engine. Use of any other brand two-stroke oil may void the limited warranty. Use only XP-S 2-stroke synthetic blend. There is no known equivalent on the market for the moment. If a high quality equivalent were available, it could be used.

⁽²⁾ If XP-S mineral injection oil is not available, API TC high-quality low ash two-stroke injection oil may be used.

XP-S mineral injection oil is a special blend of basic oil and additives specially selected to ensure unequalled lubrication, engine cleanliness and minimum spark plug fouling.

The XP-S 2-stroke synthetic blend oil provides superior lubrication, reduced engine component wear and oil deposit, thus maintaining maximum-level performance and anti-friction properties. These synthetic and synthetic blend injection oil meets the latest ASTM and JASO standards by ensuring high biodegradability and low exhaust smoke.

CAUTION: Never use four-stroke petroleum or synthetic motor oil and never mix these with outboard motor oil. Do not use NMMA TC-W, TC-W2 or TC-W3 outboard two-stroke engine oils or ashless two-stroke engine oils. Avoid mixing different brands of API TC oil as resulting chemical reactions may cause severe engine damage.

Always maintain a sufficient amount of recommended oil in the injection oil reservoir.

CAUTION: Check level and refill every time you refuel. Do not mismatch oil reservoir cap with fuel tank cap. Install cap that is identified OIL.

WARNING

Do not overfill. Reinstall cap and fully tighten. Wipe off any oil spills. Oil is highly flammable.

V800 Engine Type

Use SAE 0W 40 synthetic-based oil that meets or exceeds the requirements for API service classification SM, SL or SJ. Always check the API service label certification on the oil container, it must contain at least one of the above standards.

NOTE: This is the only recommended viscosity to ensure proper cold start and optimum engine protection at high RPM and temperature.

ENGINE TYPE	OIL TYPE
V800	XP-S 0W40 synthetic oil or an equivalent

BREAK-IN PERIOD

Engine

CAUTION: A break-in period of 10 operating hours — 500 km (300 miles) — is required before running the snowmobile at full throttle.

During break-in period, maximum throttle should not exceed 3/4 opening. However, brief full acceleration and speed variations contribute to a good break-in.

CAUTION: Engine overheating, continued wide open throttle runs and prolonged cruising without speed variations should be avoided, this can cause engine damage during the break-in period.

550F and 600 Models

To assure additional protection during the initial engine break-in, 500 mL (18 imp. oz) of recommended injection oil should be added to fuel for the first full filling of fuel tank. Have spark plugs cleaned after engine break-in.

Belt

All Models

A new drive belt requires a break-in period of 50 km (30 miles). Avoid strong acceleration/deceleration, pulling a load or high speed cruising.

10-Hour Inspection

NOTE: The 10-hour inspection is at the expense of the snowmobile owner.

As with any precision piece of mechanical equipment, we suggest that after the first 10 hours of operation — 500 km (300 miles) — or 30 days after the purchase, whichever comes first, your snowmobile be checked by an authorized SKI-DOO dealer. This inspection will also give you the opportunity to discuss the unanswered questions you may have encountered during the first hours of operation.

OPERATING INSTRUCTIONS

Pre-Operation Check

WARNING

The pre-operation check is very important prior to operating the vehicle. Always check the proper operation of critical controls, safety features and mechanical components before starting. If not done as specified here, severe injury or death might occur.

- Remove snow and ice from body including seat, footrests, controls and instruments.
- Lights — The headlamp, the taillight and the brake light are standard equipment. Be sure lights are clear of dirt, slush or snow and are in good working order or condition.
- Verify that track and idler wheels are free to turn and not frozen.

WARNING

Always use a wide base snowmobile mechanical stand to properly support vehicle during any track verification. Slowly accelerate engine in order to rotate track at very low speed when it is not on ground.

- Activate the brake control lever and make sure the brake fully applies before the brake control lever touches the handlebar grip. It must fully return when released.
- Check the parking device. Apply parking brake and check if it operates properly.
- Activate the throttle control lever several times to check that it operates easily and smoothly.

WARNING

Throttle lever must operate easily and smoothly. It must return to idle position when released.

- Check operation of tether cord cap (DESS key), engine cut-out switches, ignition switch, headlamp switch (HI-LO), taillight, brake light and pilot lamps.
- Check gear shift lever position.
- Verify that skis and steering operate freely. Check corresponding action of skis versus handlebar.
- Check fuel and injection oil for levels and leaks. Replenish as necessary and see an authorized SKI-DOO dealer in case of any leaks.
- Verify that air filter(s) is free of snow, if so equipped.
- All storage compartments must be properly latched and they must not contain any heavy or breakable objects. Hood must also be properly latched.

WARNING

All adjustable features should be positioned at optimal setting. Securely tighten all adjustment locks.

- Make certain your snowmobile is pointed away from people or objects before you start it. No one is to be standing in front of or in back of the snowmobile.
- Be warmly dressed with clothing designed for snowmobiling.

PRE-OPERATION CHECK LIST		
ITEM	OPERATION	✓
Body including seat, footrests, lights, controls and instruments	Check that there is no snow or ice.	
Track and idler wheels	Check for free movement.	
Brake lever	Check proper action.	
Parking device	Check proper action.	
Throttle lever	Check proper action.	
Switches and lights	Check proper action. Tether cord must be attached to driver clothing eyelet.	
Skis and steering	Check for free movement and proper action.	
Fuel and oil	Check for proper level and leaks.	
Air filter	Check that there is no snow or ice.	
Adjustable features	Check for optimal adjustment and securely tightened adjustment locks.	
Storage compartment	Check for proper latching and no heavy or breakable objects.	
Vehicle vicinity	Snowmobile must be pointed away from people or objects. No one is to be standing in front of or in back of the snowmobile.	
Clothing	Be warmly dressed according to weather forecast.	

SDI Engine Starting Procedure

600 HO SDI Model

General

IMPORTANT:

- If the low battery voltage pilot lamp is on, battery would not have enough power to start the engine. In this case, use the manual rewind starter.
- If the battery is dead, engine cannot be started. Have the battery recharged or replaced.

Procedure

- Recheck throttle control lever operation.
- Ensure that the tether cord cap (DESS key) is in position and that the cord is attached to your clothing eyelet.
- Ensure that the engine cut-out switch is in the ON position (up).

Manual Starting

- Grab rewind starter handle, pull handle slowly until a resistance is felt, then hold handle firmly and pull vigorously to start engine.

WARNING

Do not apply throttle while starting.

Electric Starting

- Depressing the START button will engage the electric starter and start the engine.
- Release button immediately when engine has started.

WARNING

Do not apply throttle while starting.

CAUTION: Do not engage electric starter for more than 10 seconds at a time. A rest period should be observed between the cranking cycles to allow electric starter to cool down. Using electric starter when engine has started could damage electric starter mechanism.

NOTE: If for any reason, the engine cannot be started electrically, start engine manually using the rewind starter.

Carburetor Engine Starting Procedure

550F and 600 Models

Procedure

- Recheck throttle control lever operation.
- Ensure that the tether cord cap (DESS key) is in position and that the cord is attached to your clothing eyelet.
- Ensure that the engine cut-out switch is in the ON position (up).
- On fan-cooled models, turn ignition key to ON position.
- Activate the choke according to the temperature as explained below.

Choke Application

Initial Cold Starting When Temperature is Below - 10°C (+ 15°F)

NOTE: Do not operate the throttle lever with the choke lever on.

Set the choke lever to position 3.

NOTE: After the engine is started, let engine warm up at fast idle until engine speed drops. Then, close off choke to ensure proper air-fuel mixture.

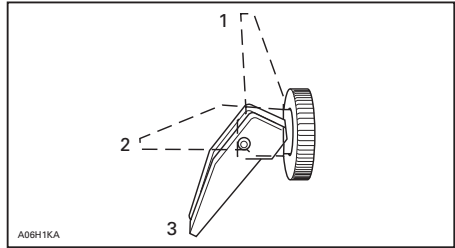

1. OFF
2. Position 2
3. Position 3

Initial Cold Starting When Temperature is Above - 10°C (above + 15°F)

Set the choke lever to position 2.

NOTE: After the engine is started, close off choke to ensure proper air-fuel mixture.

Warm Engine Starting

Start the engine without any choke. If the engine will not start after two pulls of the rope or two 5 second attempts with the electric starter move choke lever to position 2. Start the engine without activating the throttle lever. As soon as the engine starts move the choke lever to OFF.

Procedure (cont'd)

Manual Starting

- Grab rewind starter handle, pull handle slowly until a resistance is felt, then hold handle firmly and pull vigorously to start engine.

Electric Starting

WARNING

Never depress throttle while starting engine.

CAUTION: Do not engage electric starter for more than 10 seconds at a time. A rest period should be observed between the cranking cycles to allow electric starter to cool down. Using electric starter when engine has started could damage electric starter mechanism.

550F Model

- Turn key clockwise until starter engages.
- Release key immediately when engine has started.

NOTE: If for any reason, the engine cannot be started electrically, leave ignition key to ON position and start engine manually using the rewind starter.

600, 600 HO SDI and V800 Models

- Depressing the START button will engage the electric starter and start the engine.
- Release button immediately when engine has started.

NOTE: If for any reason, the engine cannot be cranked electrically, start engine manually using the rewind starter.

Engine Starting Procedure (4-stroke)

V800 Model

Procedure

- Recheck throttle control lever operation.
- Ensure that the tether cord cap (DESS key) is in position and that the cord is attached to your clothing eyelet.

- Ensure that the engine cut-out switch is in the ON position (up).

CAUTION: Do not engage electric starter for more than 10 seconds at a time. A rest period should be observed between the cranking cycles to allow electric starter to cool down. Using electric starter when engine has started could damage electric starter mechanism.

- Depressing the START button will engage the electric starter and start the engine.
- Release button immediately when engine has started.

NOTE: If for any reason, the battery is dead, engine cannot be started. Have the battery recharged or replaced.

Vehicle Warm-Up

Before every ride, vehicle has to be warmed up as follows.

Snowmobile must be securely supported by the rear bumper using a wide-base snowmobile mechanical stand. Track must be 100 mm (4 in) off the ground.

Engage parking brake.

Attach tether cord to operator's clothing eyelet.

Start engine and allow it to warm up two or three minutes at idle speed.

NOTE: Gearbox may be in neutral position.

Disengage parking brake.

WARNING

Make sure wide-base snowmobile mechanical stand is stable. Stay clear of the front of vehicle and the track. Do not use too much throttle during warm-up or when track is free-hanging.

Apply throttle until drive pulley engages. Let track rotate at low speed for several turns. The lower the vehicle temperature, the longer the warm-up should be.

Shut-off the engine and remove the wide-base snowmobile mechanical stand.

Skis may be frozen on the ground. Grab both skis one at a time by their loops and lift their front end slightly off the ground.

After restarting engine, the vehicle can be driven at low speed for the first 2 or 3 minutes of riding. After that, it may be driven up to the legal speed limit as per normal safety practices.

Shutting Off the Engine

Release throttle lever and wait until engine has returned to idle speed.

Shut off the engine using either ignition switch, engine cut-out switch or tether cord cap (DESS key) engine cut-out switch.

WARNING

Always remove tether cord cap (DESS key) and ignition key when vehicle is not in operation in order to prevent accidental engine starting or to avoid unauthorized use by children or others or theft.

Post-Operation Care

Shut off the engine. Install rear of vehicle on a wide-base snowmobile mechanical stand.

Remove snow and ice from rear suspension, track, front suspension, steering mechanism and skis.

Always cover your snowmobile when leaving it outside overnight or during extended periods of inactivity. This will protect it from frost and snow as well as help retain its appearance.

SPECIAL OPERATING INSTRUCTIONS

Riding at High Altitudes

CAUTION: Failure to re-calibrate may cause serious engine damage.

If you ride at altitudes above 600 m (2000 ft), your snowmobile should be modified. Refer to an authorized SKI-DOO dealer.

CAUTION: Do not change original factory calibration if snowmobile is used below 600 m (2000 ft).

Riding in Cold Weather

550F and 600 Models

All vehicles have been calibrated for -20°C (-4°F). They can be operated at warmer winter temperatures without risk of problems.

CAUTION: For colder temperatures than -20°C (-4°F), carburetor(s) must be recalibrated to avoid engine damage. Refer to an authorized SKI-DOO dealer.

Emergency Starting

All Models except V800

The engine can be started with the emergency starter rope supplied with the tool kit.

Remove belt guard.

WARNING

Do not wind starting rope around your hand. Hold rope by the handle only. Do not start the snowmobile by the drive pulley unless it is a true emergency situation. Have the snowmobile repaired as soon as possible.

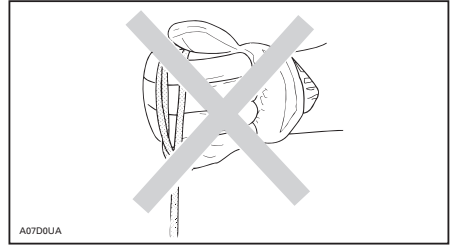

Attach one end of emergency rope to rewind handle.

NOTE: The spark plug socket can be used as an emergency handle.

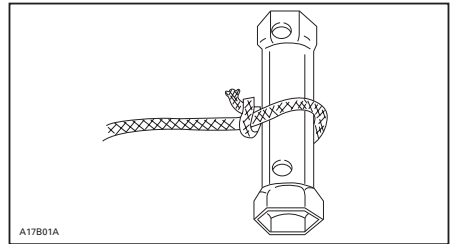

TYPICAL

Attach the other end of emergency rope to the starter clip supplied in the tool kit.

Hook up clip on drive pulley.

Wind the rope tightly around drive pulley. When pulled, pulley must rotate counterclockwise.

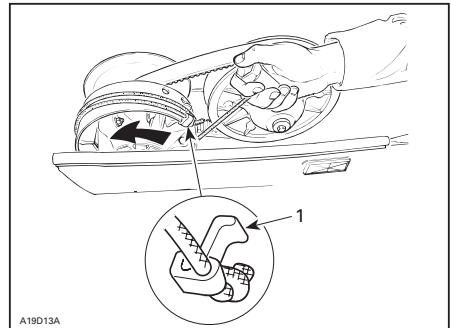

TYPICAL

1. Clip

Ensure engine cut-out switch is in ON position (up), ignition switch turned to ON position (if applicable) and tether cord cap (DESS key) is on its post. Choke as necessary (if applicable).

Pull the rope using a sharp, crisp pull so the rope comes free of the drive pulley.

Start engine as per usual manual starting.

WARNING

When starting the snowmobile in an emergency situation, using drive pulley, do not reinstall the belt guard and return slowly to have snowmobile repaired.

Towing an Accessory

Always use a rigid towbar to tow an accessory. Any towed accessory should have reflectors on both sides and at the rear. Check local laws for brake light(s) requirements.

WARNING

Never tow an accessory with a rope. Always use a rigid towbar. Using a rope would result in a collision between the object and the snowmobile and possibly in a tip over in case of a rapid deceleration or on a downward slope.

Towing Another Snowmobile

If a snowmobile is disabled and must be towed use a rigid towbar, remove the drive belt from disabled snowmobile and tow at moderate speed.

CAUTION: Always remove the drive belt of the snowmobile that is to be towed to prevent damage to its belt and drive system.

In an emergency situation only, if a rigid towbar is not available, a rope can be used provided you proceed with extra caution. (In some areas, it may be illegal to do so. Check with state or local authorities).

Remove the drive belt, attach the rope to the ski legs (spindles), have someone sit on the towed snowmobile to activate the brake, and tow at low speed.

CAUTION: In order to prevent damage to the steering system, never attach the tow rope to the ski loops (handles).

WARNING

Never ride at high speed when towing a disabled snowmobile. Proceed slowly with extra caution.

Towing an Heavy Load at Low Speed

V800 Models Only

CAUTION: When towing an heavy load at low speed, engine compartment temperature may become hot due to a lack of air circulation.

To reduce engine compartment temperature when stopping the vehicle, it is always a good practice before removing the tether cord cap (DESS key) to do the following:

- let engine idle for approximately 30 seconds
- stop engine using the engine cut-out switch
- engine cooling fan should continue to work for approximately 30 to 45 seconds
- when engine cooling fan stops, remove tether cord cap (DESS key).

NOTE: Removing tether cord cap (DESS key) will stop engine cooling fan automatically.

Transporting the Vehicle

Make sure that oil reservoir and fuel tank caps are properly installed.

Tilt bed trailers can easily be equipped with a winch mechanism to afford maximum safety in loading. Simple as it may seem, never drive your snowmobile onto a tilt bed trailer or any other kind of trailer or vehicle. Many serious accidents have resulted from driving up and over a trailer. Anchor your vehicle securely, front and rear, even on short hauls. Be certain all equipment is securely fastened. Cover your snowmobile when trailering to prevent road grime from causing damage.

Be certain your trailer meets state or provincial requirements. Ensure the hitch and safety chains are secure and the brake, turn indicators and clearance lights all function.

SUSPENSION ADJUSTMENTS

Snowmobile handling and comfort depends on suspension adjustments.

Choice of suspension adjustments vary with carrying load, driver's weight, personal preference, riding speed and field condition.

NOTE: Some adjustments may not apply to your snowmobile. Use special keys in tool kit.

The following is to fine-tune suspension.

The best way to set up a suspension, is to start from factory settings, then customize each adjustment one at a time. Adjustments 2 through 6 are interrelated. It may be necessary to readjust center spring after adjusting front springs for instance. Test run the snowmobile under the same conditions; trail, speed, snow, driver riding position, etc. Change one adjustment and retest. Proceed methodically until you are satisfied.

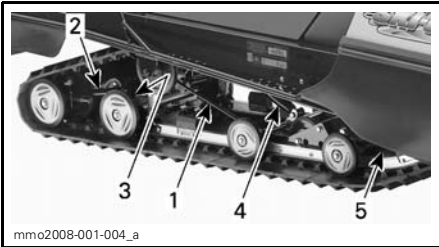

mmo2008-001-004_a

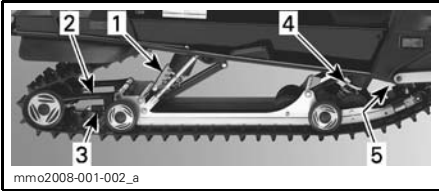

mmo2008-001-002_a

TYPICAL — REAR SUSPENSION

1. Rear spring(s) — comfort and ride height
2. Suspended extension — reverse performance, load and snow conditions
3. Shackle movement — reverse performance, load and snow conditions
4. Center spring — handling
5. Stopper strap — snowmobile weight transfer



mmo2008-001-003_a

TYPICAL — FRONT SUSPENSION

1. Front shock — handling

WARNING

Do not attempt to lift the vehicle by hand alone. Use appropriate lifting device or have assistance to share lifting stress in order to avoid risk of strain injuries.

WARNING

Always remove tether cord cap (DESS key) before performing any maintenance or adjustment, unless otherwise specified. Vehicle must be parked in a safe place, away from the trail. Always lift the front of vehicle off the ground with a suitable lifting device before adjusting ski suspension. Lift the rear of vehicle off the ground with a suitable lifting device before rear suspension adjustment.

CAUTION: Whenever adjusting rear suspension, check track tension and adjust as necessary.

Slight suspension bottoming occurring under the worst riding conditions indicates a good choice of spring preload.

1. Rear Springs — Comfort

IMPORTANT: Make sure that all objects to be transported are in place in rear rack and under the seat.

- Grab rear bumper and lift until suspension is fully extended.
- From this point, rear of snowmobile should collapse by 50 to 75 mm (2 to 3 in) when driver, passenger (if so applicable) and load take place.
- Measure at rear bumper as shown in next illustration.

⚠ WARNING

Do not attempt to lift the vehicle by hand alone. Use appropriate lifting device or have assistance to share lifting stress in order to avoid risk of strain injuries.

Rear Springs Adjustment

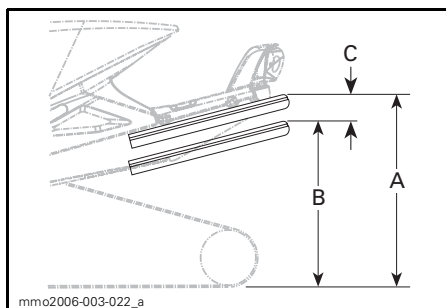

TYPICAL — PROPER ADJUSTMENT

- Suspension fully extended
- Suspension has collapse with driver, passenger and load added
- Distance between dimension A and B, must not exceed 50 to 75 mm (2 to 3 in), see table

REAR SPRINGS ADJUSTMENT		
"C"	CAUSE	SOLUTION
50 to 75 mm (2 to 3 in)	No adjustment required	
More than 75 mm (3 in)	Adjusted too soft	Increase preload (see preload adjustment)
Less than 50 mm (2 in)	Adjusted too hard	Decrease preload (see preload adjustment)

Increase Spring Preload

Skandic SWT/WT Only

CAUTION: To increase preload, always turn the left side adjustment cam in a clockwise direction, and the right side cam in a counterclockwise direction. Left and right adjustment cams may be at different settings.

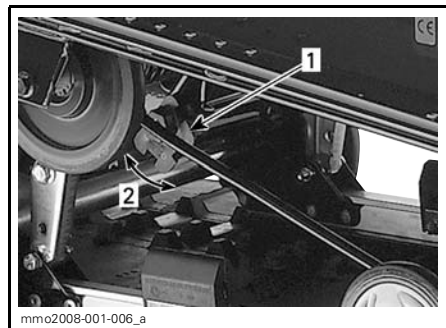

TYPICAL

- Adjustment cam
- Turn to increase spring preload

Skandic SUV/Expedition TUV Only

From the lowest position, turn adjuster to select highest position, then turn adjuster to the desired position.

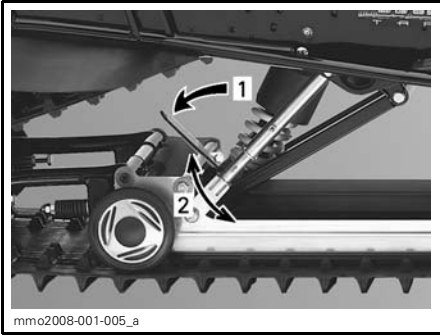

TYPICAL

1. Pull on handle
2. Turn to increase spring preload

Decrease Spring Preload

Skandic SWT/WT Only

CAUTION: To decrease preload, always turn the left side adjustment cam in a counterclockwise direction, the right side cam in a clockwise direction. Left and right adjustment cams may be at different settings.

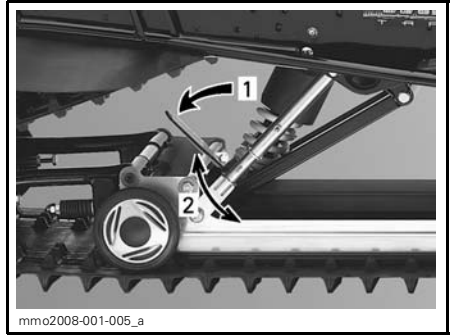

TYPICAL

1. Pull on handle
2. Turn to decrease spring preload

2. Suspended Extension Adjustment

Suspended extension can be adjusted according to the load and snow conditions.

For better deep snow performance or to increase reverse performance in deep snow, first loosen lock nut, then tighten nut 3/4 turn after contacting washers. Retighten lock nut. Adjust the same on both sides.

For trail riding with a load or for pulling a load, first loosen lock nut. Turn to a maximum preload of 3 turns after nut touching washers. Retighten lock nut. Adjust the same on both sides.

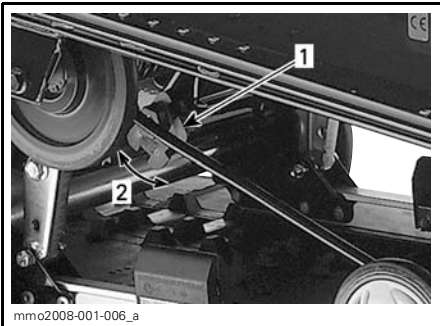

TYPICAL

1. Pull on handle
2. Turn to decrease spring preload

Skandic SUV/Expedition TUV Only

From the highest position, turn adjuster to select lowest position, then turn adjuster to the desired position.

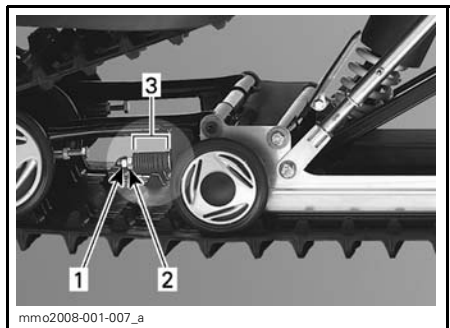

TYPICAL

1. Lock nut
2. Nut
3. Washers

3. Shackle Movement Limiter

For deep snow riding, do not install horse shoe washers.

For trail riding with passenger and/or weight, install 1 horse shoe washer under each rubber stoppers.

For trail riding with heavy load and/or pulling a load, use 2 horse shoe washers under each rubber stoppers.

CAUTION: Always install same amount of washers on both sides.

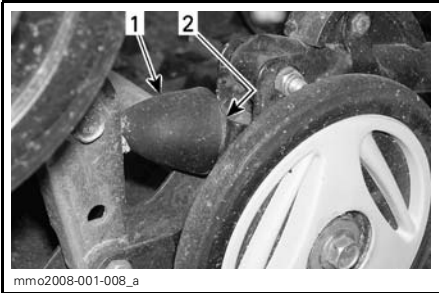

TYPICAL

1. Rubber stopper
2. Horse shoe washer(s)

4. Center Spring — Steering Behavior

Skandic SUV/Expedition TUV Only

- Ride at moderate speed on a trail.
- If handlebar seems too easy or too hard to turn, adjust center spring accordingly.

⚠ WARNING

Before proceeding with any suspension adjustment, remember:

- Park in a safe place.
- Remove tether cord cap (DESS key).
- Lift rear of vehicle off the ground with suitable lifting device.
- Make sure lifting device is stable and secure.

CENTER SPRING ADJUSTMENT		
HANDLEBAR (steering attitude)	PROBLEM	SOLUTION
Easy to turn (neutral)	No adjustment required	
Harder to turn (oversteering)	Adjusted too soft	Increase preload
Very easy to turn (understeering)	Adjusted too hard	Decrease preload

Increase Spring Preload

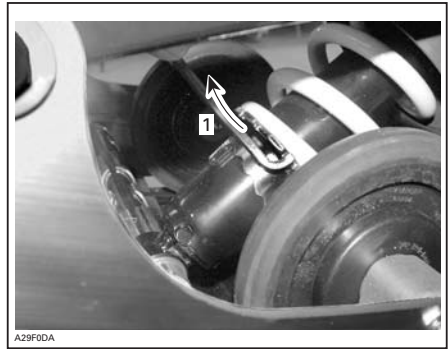

1. Use adjuster wrench provided in tool kit to increase preload

Decrease Spring Preload

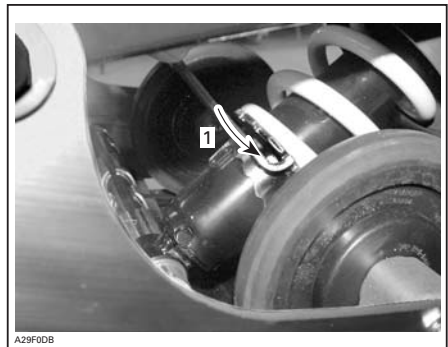

1. Use adjuster wrench provided in tool kit to decrease preload

5. Stopper Strap — Weight Transfer

- Ride at low speed, then fully accelerate.
- Note steering behavior.
- Adjust stopper strap length accordingly.

CAUTION: Whenever stopper strap length is changed, track tension must be readjusted.

WARNING

Before proceeding with any suspension adjustment, remember:

- Park in a safe place.
- Remove tether cord cap (DESS key).
- Lift rear of vehicle off the ground with suitable lifting device.
- Make sure lifting device is stable and secure.

STOPPER STRAP

WEIGHT TRANSFER		ADJUSTMENTS	
STEERING	TRACK (skis)	PROBLEM	SOLUTION
Comfortable	Good weight transfer (light pressure)	No adjustment required	
Light	Too much weight transfer (lift off the ground)	Strap too long	Reduce strap length
Heavy	Not enough weight transfer (heavy pressure)	Strap too short	Increase strap length

Strap Length Adjustment

Skandic WT/SWT

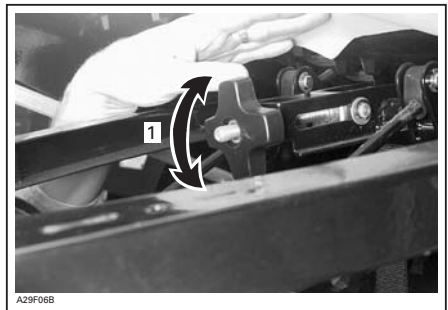

1. Screw or unscrew knob to vary strap length

Skandic SUV/Expedition TUV

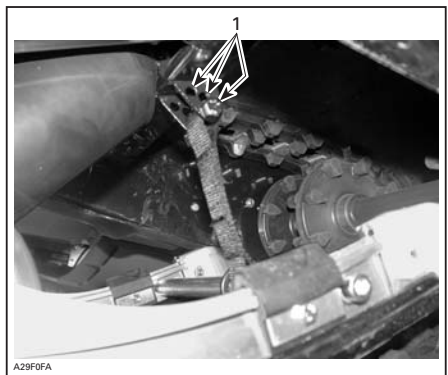

1. Bolt stopper strap to a different hole

6. Front Suspension Springs — Handling

- Ride at moderate speed and check for proper handling.
- Adjust front springs accordingly.

WARNING

Before proceeding with any suspension adjustment, remember:

- Park in a safe place.
- Remove tether cord cap (DESS key).
- Lift rear of vehicle off the ground with suitable lifting device.
- Make sure lifting device is stable and secure.

WARNING

Always adjust both front springs to same position.

FRONT SPRINGS ADJUSTMENT

HANDLING (steering)	PROBLEM	SOLUTION
Good (comfortable)	No adjustment required	
Bad (too easy to turn)	Adjustment too soft	Increase spring preload
Bad (hard to turn)	Adjustment too hard	Decrease spring preload

Increase Spring Preload

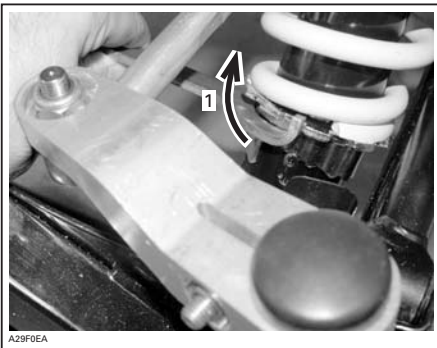

1. Increase spring preload

Decrease Spring Preload

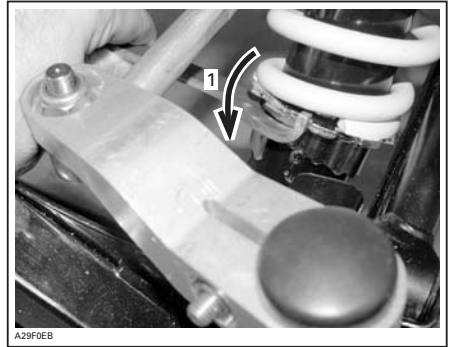

1. Decrease spring preload

SUSPENSION TROUBLESHOOTING CHART

PROBLEM	CORRECTIVE MEASURES
Front suspension wandering	<ul style="list-style-type: none"> – Check ski alignment and camber angle adjustment. – See an authorized SKI-DOO dealer. – Reduce ski ground pressure. <ul style="list-style-type: none"> • Reduce front suspension spring preload. • Increase center spring preload. • Reduce rear spring preload.
Snowmobile seems unstable and seems to pivot around its center	<ul style="list-style-type: none"> – Reduce rear suspension front arm pressure. <ul style="list-style-type: none"> • Reduce center spring preload. • Increase rear spring preload. • Increase front suspension spring preload.
Steering feels too heavy	<ul style="list-style-type: none"> – Reduce ski ground pressure. <ul style="list-style-type: none"> • Reduce front suspension spring preload. • Increase center spring preload.
Rear of snowmobile seems too stiff	<ul style="list-style-type: none"> – Reduce rear spring preload.
Rear of snowmobile seems too soft	<ul style="list-style-type: none"> – Increase rear spring preload.
Rear suspension front shock absorber is frequently bottoming	<ul style="list-style-type: none"> – Lengthen stopper strap. – Increase center spring preload.
Track spins too much at start	<ul style="list-style-type: none"> – Lengthen stopper strap. – Change driving position.

In Deep Snow

When operating the snowmobile in deep snow, it may be necessary to vary extension adjustment, stopper strap and/or riding position, to change the angle at which the track rides on the snow. Operator's familiarity with the various adjustments as well as snow conditions will dictate the most efficient combination.

TROUBLESHOOTING

ENGINE OVERHEATING (fan cooled)

1. Engine is too hot, shut off the engine.

- Check for clogged air duct passages. Remove any foreign materials. Check for proper fan belt condition and tension. See an authorized SKI-DOO dealer.

ENGINE OVERHEATING (liquid cooled)

1. Engine overheating pilot lamp will light up if engine is too hot.

- Reduce snowmobile speed and run snowmobile in loose snow or stop engine immediately.
- Check for adequate coolant level. See an authorized SKI-DOO dealer.

FUEL FLOODED ENGINE

1. Never depress throttle while starting engine, even if flooded with gas.

- Install new spark plugs and restart engine.

REAR SUSPENSION SLIDER SHOE STICKING

1. Slider shoes are cooled and lubricated by snow. When riding at moderate or high speed on a thin-snow-covered surface, slider shoes may stick on metallic track guides.

- Run snowmobile on a surface covered by snow or drive snowmobile at very slow speed.
- Have slider shoes inspected by an authorized SKI-DOO dealer.

ENGINE CRANKS BUT FAILS TO START

1. Ignition switch or engine cut-out switch is in OFF position or tether cord cap (DESS key) away from its post.

- Place engine cut-out switch in the ON position (up) and install tether cord cap (DESS key) on its post.

2. Mixture not rich enough to start cold engine.

- Check fuel tank level and check starting procedure, particularly use of the choke.

3. Flooded engine (spark plug wet when removed).

- Do not choke. Remove wet spark plug, turn ignition switch or engine cut-out switch to OFF position and crank engine several times. Install clean dry spark plug. Start engine following usual starting procedure. If engine continues to flood, see an authorized SKI-DOO dealer.

4. No fuel to the engine (spark plug dry when removed).

- Check fuel tank level; check fuel filter; replace if clogged; check condition of fuel and impulse lines and their connections. A failure of the fuel pump, throttle body or carburetor has occurred. Contact an authorized SKI-DOO dealer.

ENGINE CRANKS BUT FAILS TO START (cont'd)

5. Spark plug/ignition (no spark).

- *Remove spark plug(s), then reconnect to spark cap. Check that engine cut-out switch is at the ON position (up) and the tether cord cap (DESS key) on its post. Start engine with spark plug(s) grounded to engine away from spark plug hole. If no spark appears, replace spark plug. If trouble persists, contact an authorized SKI-DOO dealer.*

6. Engine compression.

- *As the engine is pulled over with the rewind starter, "cycles" of resistance should be felt as piston goes past top dead center (each piston on multi-cylinder engines). If no pulsating resistance is felt, it suggests a major loss of compression. Contact an authorized SKI-DOO dealer.*

ENGINE LACKS ACCELERATION OR POWER

1. DESS did not read tether cord cap (DESS key) code. DESS pilot lamp blinks once every 1.5 seconds. Engine can not exceed 3000 RPM.

- *Properly install tether cord cap (DESS key).*

2. DESS has read a different tether cord cap (DESS key) code than the one programmed. DESS pilot lamp blinks rapidly (3 times per second). Engine can not exceed 3000 RPM.

- *Install a tether cord cap (DESS key) for which this snowmobile was programmed.*

3. Fouled or defective spark plug.

- *Check item 5 of ENGINE TURNS OVER BUT FAILS TO START.*

4. Lack of fuel to engine.

- *Check item 4 of ENGINE TURNS OVER BUT FAILS TO START.*

5. Carburetor adjustments.

- *Contact an authorized SKI-DOO dealer.*

6. Drive belt worn too thin.

- *If the drive belt has lost more than 3 mm (1/8 in) of its original width, it will affect vehicle performance. Replace drive belt.*

7. Drive and driven pulleys require servicing.

- *Contact an authorized SKI-DOO dealer.*

8. Engine is overheating.

- *On liquid cooled engines, check coolant level, pressure cap, thermostat and for air locks in cooling system. On fan cooled engines, check fan belt and its tension; clean cooling fins of engine; if overheating persists, contact an authorized SKI-DOO dealer.*

ENGINE BACKFIRES

1. DESS did not read tether cord cap (DESS key) code. DESS pilot lamp blinks once every 1.5 seconds. Engine can not exceed 3000 RPM.

- *Properly install tether cord cap (DESS key).*

ENGINE BACKFIRES (cont'd)

- 2. DESS has read a different tether cord cap (DESS key) code than the one programmed. DESS pilot lamp blinks rapidly (3 times per second). Engine can not exceed 3000 RPM.**
 - *Install a tether cord cap (DESS key) for which this snowmobile was programmed.*
- 3. Faulty spark plug (carbon accumulation).**
 - *See item 5 of ENGINE TURNS OVER BUT FAILS TO START.*
- 4. Engine is running too hot.**
 - *See item 6 of ENGINE LACKS ACCELERATION OR POWER.*
- 5. Ignition timing is incorrect or there is an ignition system failure.**
 - *Contact an authorized SKI-DOO dealer.*

ENGINE MISFIRES

- 1. DESS did not read tether cord cap (DESS key) code. DESS pilot lamp blinks once every 1.5 seconds. Engine can not exceed 3000 RPM.**
 - *Properly install tether cord cap (DESS key).*
- 2. DESS has read a different tether cord cap (DESS key) code than the one programmed. DESS pilot lamp blinks rapidly (3 times per second). Engine can not exceed 3000 RPM.**
 - *Install a tether cord cap (DESS key) for which this snowmobile was programmed.*
- 3. Fouled/defective/worn spark plugs.**
 - *Clean/verify spark plug gap and identification number. Replace as required.*
- 4. Too much oil supplied to engine (2-stroke).**
 - *Improper oil pump adjustment, refer to an authorized SKI-DOO dealer.*
- 5. Water in fuel.**
 - *Drain fuel system and refill with fresh fuel.*

SNOWMOBILE CANNOT REACH FULL SPEED

- 1. DESS did not read tether cord cap (DESS key) code. DESS pilot lamp blinks once every 1.5 seconds. Engine can not exceed 3000 RPM.**
 - *Properly install tether cord cap (DESS key).*
- 2. DESS has read a different tether cord cap (DESS key) code than the one programmed. DESS pilot lamp blinks rapidly (3 times per second). Engine can not exceed 3000 RPM.**
 - *Install a tether cord cap (DESS key) for which this snowmobile was programmed.*
- 3. Drive belt.**
 - *Check item 6 of ENGINE LACKS ACCELERATION OR POWER.*
- 4. Incorrect track adjustment.**
 - *See MAINTENANCE and/or an authorized SKI-DOO dealer for proper alignment and tension adjustments.*
- 5. Pulleys misaligned.**
 - *Contact an authorized SKI-DOO dealer.*

SNOWMOBILE CANNOT REACH FULL SPEED (cont'd)

6. Engine.

- *See items 1, 2, 6 and 7 of ENGINE LACKS ACCELERATION OR POWER.*

Engine Management System (EMS) Faults

NOTE: For any fault code not listed below, refer to an authorized SKI-DOO dealer.

600 HO SDI Model

2 SHORT BEEPS PER MINUTE.

1. Low battery voltage.

- *Check battery and charging system.*

2 SHORT BEEPS PER MINUTE AND DESS PILOT LAMP BLINKS.

1. High battery voltage.

- *Check battery and charging system.*

DESS PILOT LAMP BLINKS.

1. Engine Management System (EMS) fault code.

- *See an authorized SKI-DOO dealer.*

V800 Model

ENGINE MANAGEMENT SYSTEM PILOT LAMP BLINKS.

1. Engine Management System (EMS) fault code.

- *See an authorized SKI-DOO dealer.*

ENGINE MANAGEMENT SYSTEM PILOT LAMP BLINKS AND 2 SECOND BEEP EVERY 15 MINUTES.

1. Low or high battery voltage.

- *Check battery and charging system.*

SPECIFICATIONS

MODEL		SKANDIC WT/SUV/SWT
		550F
ENGINE		
Engine type		552
Number of cylinder		2
Bore	mm (in)	76 (2.992)
Stroke	mm (in)	61.00 (2.402)
Displacement	cm ³ (in ³)	553.40 (33.771)
Maximum horsepower RPM	± 100 RPM	6900
COOLING SYSTEM		
Type		Fan
Axial fan belt adjustment	Deflection	mm (in)
	Force	kgf (lbf)
		9.5 ± 1.5 (.37 ± .06)
		5.0 (11.0)
LUBRICATION SYSTEM		
Injection oil	Type	XP-S mineral injection oil
	Quantity	L (U.S. oz)
		2.5 (84.5)
FUEL SYSTEM		
Gas type		Unleaded
Pump octane number	Inside North America ((R+M)/2)	87 or higher
	Outside North America (RON)	92 or higher
Fuel tank capacity	L (U.S. gal)	42 (11.1)
Gas/oil ratio		Injection

MODEL		SKANDIC WT/SUV/SWT	
		550F	
ELECTRICAL SYSTEM			
Magneto generator output		340 W @ 6000 RPM	
Ignition type		CDI by Ducati	
Spark plug	Make and type		NGK BR9ES
	Gap	mm (in)	0.40 to 0.60 (.016 to .024)
Battery		12 V, 18 A•h	
Headlamp	W	60/55 (H4)	
Taillight and stoplight	W	8/27	
Fuse		Refer to <i>FUSES</i> section	
DRIVE SYSTEM			
Gearbox oil	Type		XP-S synthetic chaincase oil
	Quantity mL (U.S. oz)		500 (16.9)
Gear ratio	SWT	1 st	1 : 3.80
		2 nd	1 : 2.29
		R	1 : 4.63
	Others	1 st	1 : 2.93
		2 nd	1 : 2.04
		R	1 : 3.57
Drive pulley type		Bombardier Lite	
Drive pulley calibration	Clutch engagement	± 100 RPM	2500
Driven pulley type		6-K VSA	
Drive belt		P/N	605 348 425 ⁽³⁾
Drive belt	Width	mm (in)	37.3 (1.469)
	Wear limit	mm (in)	35.8 (1.409)
Drive belt adjustment	Deflection	mm (in)	32 ± 5 (1.260 ± .197)
	Force	kgf (lbf)	11.34 (25)

MODEL			SKANDIC WT/SUV/SWT		
			550F		
DRIVE SYSTEM (cont'd)					
Track	Width	WT	mm (in)	500 (20)	
		SWT	mm (in)	600 (24)	
		SUV	mm (in)	500 (20)	
	Length	m (in)		3.968 (156)	
	Profile height	mm (in)		31.8 (1.25)	
Track adjustment	Deflection ⁽¹⁾	mm (in)		40 to 50 (1.181 to 1.378)	
	Force ⁽¹⁾	kgf (lbf)		7.3 (16)	
	Alignment			⁽²⁾	
BRAKE SYSTEM					
Brake lining thickness	Service limit	mm (in)		1 (.039)	
Brake fluid	Type		DOT 4		
	Quantity	mL (U.S. oz)		60 (2.0)	
SUSPENSION					
<i>FRONT</i>					
Suspension type	SUV		SUV		
	WT/SWT		LTS		
Suspension maximum travel			mm (in)		151 (5.95)
Shock absorber type					Hydraulic
<i>REAR</i>					
Suspension type	WT/SWT		Easy ride WLS		
	SUV		RCG1-W		
Suspension maximum travel	WT/SWT	mm (in)		210 (8.23)	
	SUV	mm (in)		290 (11.42)	
Shock absorber type	Center	WT/SWT		—	
		SUV		Gas	
	Rear	WT/SWT		Gas	
		SUV		HPG	

MODEL		SKANDIC WT/SUV/SWT	
		550F	
STEERING SYSTEM			
Ski type		ADJ	
Toe-out		mm (in)	5 (.197)
Camber		0°	
VEHICLE INFORMATION			
Mass (dry)	WT	kg lb	285 (628.3)
	SWT	kg lb	302 (665.8)
	SUV	kg lb	300 (661.4)
Length	WT	m (in)	3.06 (120)
	SWT	m (in)	3.06 (120)
	SUV	m (in)	3.06 (120)
Width		m (in)	1.08 (42.5)
Height		m (in)	1.3 (51)
Ski stance (carbide to carbide)	SUV	mm (in)	985 (38.8)
	WT/SWT	mm (in)	900 (35.4)

- (1) Measure gap between slider shoe and bottom inside of track when exerting a downward pull to the track.
- (2) Equal distance between edges of track guides and slider shoes.
- (3) Drive belt height must be adjusted every time a new drive belt is installed. Confirm drive belt part number application with an authorized SKI-DOO dealer.

MODEL		SKANDIC WT
		600
ENGINE		
Engine type		593
Number of cylinder		2
Bore	mm (in)	76 (2.992)
Stroke	mm (in)	65.8 (2.591)
Displacement	cm ³ (in ³)	597 (36.43)
Maximum horsepower RPM	± 100 RPM	7000
COOLING SYSTEM		
Coolant	Type	Ethyl glycol and distilled water (50%/ 50%). Use premix coolant from BRP (P/N 219 700 362) or coolant specifically formulated for aluminum engines
	Quantity	L (U.S. gal.) 4.9 (1.29)
LUBRICATION SYSTEM		
Injection oil	Type	XP-S mineral injection oil
	Quantity	L (U.S. oz) 3.5 (118)
FUEL SYSTEM		
Gas type		Unleaded
Pump octane number	Inside North America ((R+M)/2)	87 or higher
	Outside North America (RON)	92 or higher
Fuel tank capacity		L (U.S. gal) 42 (11.1)
Gas/oil ratio		Injection
ELECTRICAL SYSTEM		
Magneto generator output		W 360 @ 6000 RPM
Ignition type		C.D.I. by Denso
Spark plug	Make and type	NGK BR9ECS
	Gap	mm (in) 0.40 to 0.50 (.016 to .020)
Battery		12 V, 18 A•h (with electric starter)
Headlamp		W 60/55 (H4)
Taillight and stoplight		W 8/27
Fuse		Refer to <i>FUSES</i> section

MODEL		SKANDIC WT
		600
DRIVE SYSTEM		
Gearbox oil	Type	XP-S synthetic chaincase oil
	Quantity	mL (U.S. oz) 500 (16.9)
Gear ratio	1 st	1 : 2.82
	2 nd	1 : 1.70
	R	1 : 3.44
Drive pulley type		TRA III
Drive pulley calibration	Clutch engagement	2700 ± 100 RPM
Driven pulley type		6-K VSA
Drive belt		P/N 605 348 425 ⁽³⁾
Drive belt	Width	mm (in) 37.3 (1.469)
	Wear limit	mm (in) 35.8 (1.409)
Drive belt adjustment	Deflection	mm (in) 40 to 50 (1.575 to 1.969)
	Force	kgf (lbf) 11.30 (24.91)
Track	Width	mm (in) 500 (20)
	Length	m (in) 3.968 (156)
	Profile height	mm (in) 31.8 (1.25)
Track adjustment	Deflection ⁽¹⁾	mm (in) 40 to 50 (1.575 to 1.969)
	Force ⁽¹⁾	kgf (lbf) 7.3 (16)
	Alignment	⁽²⁾
BRAKE SYSTEM		
Brake lining thickness	Service limit	mm (in) 1 (.039)
Brake fluid	Type	DOT 4
	Quantity	mL (U.S. oz) 60 (2.0)

MODEL		SKANDIC WT
		600
SUSPENSION		
<i>FRONT</i>		
Suspension type		LTS
Suspension maximum travel		mm (in) 151 (6)
Shock absorber type		Hydraulic
<i>REAR</i>		
Suspension type		Easy ride WLS
Suspension maximum travel		mm (in) 210 (8.3)
Shock absorber type	Center	—
	Rear	Sealed 36
STEERING SYSTEM		
Ski type		ADJ
Toe-out		mm (in) 5 (.197)
Camber		0°
VEHICLE INFORMATIONS		
Mass (dry)		kg (lb) 304 (670)
Length		m (in) 3.06 (120)
Width		m (in) 1.08 (42.5)
Height		m (in) 1.30 (51)
Ski stance (carbide to carbide)		mm (in) 900 (35.4)

- (1) Measure gap between slider shoe and bottom inside of track when exerting a downward pull to the track.
- (2) Equal distance between edges of track guides and slider shoes.
- (3) Drive belt height must be adjusted every time a new drive belt is installed. Confirm drive belt part number application with an authorized SKI-DOO dealer.

MODEL		EXPEDITION TUV/ SKANDIC SUV
		600 HO SDI
ENGINE		
Engine type		593 HO SDI
Number of cylinder		2
Bore	mm (in)	72 (2.835)
Stroke	mm (in)	73 (2.874)
Displacement	cm ³ (in ³)	594.40 (36.273)
Maximum horsepower RPM	± 100 RPM	8000
COOLING SYSTEM		
Coolant	Type	Ethyl glycol and distilled water (50%/ 50%). Use premix coolant from BRP (P/N 219 700 362) or coolant specifically formulated for aluminum engines
	Quantity	L (U.S. gal.) 4.5 (1.2)
LUBRICATION SYSTEM		
Injection oil	Type	XP-S 2-stroke synthetic blend
	Quantity	L (U.S. oz) 2.5 (84.5)
FUEL SYSTEM		
Gas type		Unleaded
Pump octane number	Inside North America ((R+M)/2)	87 or higher
	Outside North America (RON)	92 or higher
Fuel tank capacity		L (U.S. gal) 42 (11.1)
Gas/oil ratio		Injection
ELECTRICAL SYSTEM		
Magneto generator output		W 480 @ 6000 RPM
Ignition type		Inductive by BOSCH
Spark plug	Make and type	NGK BR8ECS
	Gap	mm (in) 0.85 (.033)
Battery		12 V, 18 A•h
Headlamp		W 60/55 (H4)
Taillight and stoplight		W 8/27
Fuse		Refer to <i>FUSES</i> section

MODEL		EXPEDITION TUV/ SKANDIC SUV	
		600 HO SDI	
DRIVE SYSTEM			
Gearbox oil	Type		XP-S synthetic chaincase oil
	Quantity	mL (U.S. oz)	500 (16.9)
Gear ratio	1 st		1 : 2.82
	2 nd		1 : 1.70
	R		1 : 3.44
Drive pulley type			TRA III
Drive pulley calibration	Clutch engagement		3000 ± 100 RPM
Driven pulley type			6-K VSA
Drive belt		P/N	605 348 425 ⁽³⁾
Drive belt	Width	mm (in)	37.3 (1.469)
	Wear limit	mm (in)	35.8 (1.409)
Drive belt adjustment	Deflection	mm (in)	32 ± 5 (1.260 ± .197)
	Force	kgf (lbf)	11.30 (24.91)
Track	Width	mm (in)	500 (20)
	Length	m (in)	3.968 (156)
	Profile height	mm (in)	31.8 (1.25)
Track adjustment	Deflection ⁽¹⁾	mm (in)	40 to 50 (1.575 to 1.969)
	Force ⁽¹⁾	kgf (lbf)	7.3 (16)
	Alignment		⁽²⁾
BRAKE SYSTEM			
Brake lining thickness	Service limit	mm (in)	1 (.039)
Brake fluid	Type		DOT 4
	Quantity	mL (U.S. oz)	500 (17)

MODEL	EXPEDITION TUV/ SKANDIC SUV	
	600 HO SDI	
SUSPENSION		
<i>FRONT</i>		
Suspension type	SUV	
Suspension maximum travel	mm (in)	200 (7.9)
Shock absorber type	HPG	
<i>REAR</i>		
Suspension type	RCG1-W	
Suspension maximum travel	mm (in)	290 (11.4)
Shock absorber type	Center	HPG
	Rear	HPG
Stroke limiter standard position	4-2	
STEERING SYSTEM		
Ski type	ADJ	
Toe-out	mm (in)	5 (.197)
Camber	0°	
VEHICLE INFORMATION		
Mass (dry)	kg (lb)	330 (728)
Length	m (in)	3.06 (120.5)
Width	m (in)	1.17 (46)
Height	m (in)	1.31 (52)
Ski stance (carbide to carbide)	mm (in)	985 (38.8)

- (1) Measure gap between slider shoe and bottom inside of track when exerting a downward pull to the track.
- (2) Equal distance between edges of track guides and slider shoes.
- (3) Drive belt height must be adjusted every time a new drive belt is installed. Confirm drive belt part number application with an authorized SKI-DOO dealer.

MODEL		EXPEDITION TUV/SKANDIC SWT
		V800
ENGINE		
Engine type		ROTAX™ V810
		4-stroke, Single Over Head Camshaft (SOHC), liquid cooled
Number of cylinders		2
Number of valves		8 valves (mechanical adjustment)
Bore	mm (in)	91 (3.58)
Stroke	mm (in)	61.5 (2.42)
Displacement	cm ³ (in ³)	800 (48.82)
Maximum horsepower RPM	± 100 RPM	7250
COOLING SYSTEM		
Coolant		Type
		Quantity L (U.S. gal.)
		Ethyl glycol and distilled water (50%/ 50%). Use premix coolant from BRP (P/N 219 700 362) or coolant specifically formulated for aluminum engines
		4.00 (1.06)
LUBRICATION SYSTEM		
Lubrication		Type
		Oil filter
		Capacity (oil change with filter)
		Recommended
		Wet sump. Replaceable oil filter
		BRP Rotax paper type, replaceable
		2.3 L (2.4 quarts)
		XP-S 0W40 synthetic oil or an equivalent

MODEL		EXPEDITION TUV/SKANDIC SWT	
		V800	
FUEL SYSTEM			
Gas type		Unleaded	
Pump octane number	Inside North America ((R+M)/2)		87 or higher
	Outside North America (RON)		92 or higher
Fuel tank capacity		L (U.S. gal)	41 (10.8)
ELECTRICAL SYSTEM			
Magneto generator output		W	460 @ 6000 RPM
Ignition type		CDI (Capacity Discharge Ignition) by DENSO	
Spark plug	Make and type		NGK DCPR8E
	Gap	mm (in)	0.75 (.0303)
Battery		12 V, 21 A•h	
Headlamp		W	60/55 (H4)
Taillight and stoplight		W	8/27
Fuse		Refer to <i>FUSES</i> section	
DRIVE SYSTEM			
Gearbox oil	Type		XP-S synthetic chaincase oil
	Quantity		mL (U.S. oz)
Gear ratio	SWT	1 st	1 : 3.80
		2 nd	1 : 2.29
		R	1 : 4.63
	TUV	1 st	1 : 2.82
		2 nd	1 : 2.04
		R	1 : 3.44
Drive pulley type		TRA IV	
Drive pulley calibration	Clutch engagement		2500 ± 100 RPM
Driven pulley type		6-K VSA	
Drive belt		P/N	605 348 425 ⁽³⁾
Drive belt	Width		mm (in)
	Wear limit		mm (in)

MODEL			EXPEDITION TUV/SKANDIC SWT
			V800
DRIVE SYSTEM (cont'd)			
Drive belt adjustment	Deflection	mm (in)	32 ± 5 (1.260 ± .197)
	Force	kgf (lbf)	11.30 (24.91)
Track	Width	SWT mm (in)	600 (24)
		TUV mm (in)	500 (20)
	Length	m (in)	3.968 (156)
	Profile height	mm (in)	31.8 (1.25)
Track adjustment	Deflection ⁽¹⁾	mm (in)	40 to 50 (1.575 to 1.969)
	Force ⁽¹⁾	kgf (lbf)	7.3 (16)
BRAKE SYSTEM			
Brake lining thickness	Service limit	mm (in)	1 (.039)
Brake fluid	Type		DOT 4
	Quantity	mL (U.S. oz)	500 (17)
SUSPENSION			
<i>FRONT</i>			
Suspension type	SWT		LTS
	TUV		SUV
Suspension maximum travel	SWT mm (in)		150 (6)
	TUV mm (in)		200 (8)
Shock absorber type			Motion control
<i>REAR</i>			
Suspension type	SWT		Easy ride XWLS
	TUV		RCG1-W
Suspension maximum travel	SWT mm (in)		210 (8.3)
	TUV mm (in)		293 (11.5)
Shock absorber type	Center		Motion control
	Rear		HPG

MODEL		EXPEDITION TUV/SKANDIC SWT
		V800
STEERING SYSTEM		
Ski type		ADJ
Toe-out	mm (in)	5 (.197)
Camber		0°
VEHICLE INFORMATIONS		
Mass (dry)		kg (lb) 330 (728)
Length		m (in) 3.06 (120.5)
Width	SWT	m (in) 1.08 (42.5)
	TUV	m (in) 1.22 (48)
Height		m (in) 1.36 (53.5)
Ski stance (carbide to carbide)	SWT	mm (in) 900 (35.4)
	TUV	mm (in) 985 (38.8)

- (1) Measure gap between slider shoe and bottom inside of track when exerting a downward pull to the track.
- (2) Equal distance between edges of track guides and slider shoes.
- (3) Drive belt height must be adjusted every time a new drive belt is installed. Confirm drive belt part number application with an authorized SKI-DOO dealer.

MAINTENANCE INFORMATION

PERIODIC MAINTENANCE CHART

WARNING

It is recommended that the assistance of an authorized SKI-DOO dealer be periodically obtained on other components/systems not covered in this guide. Unless otherwise specified, engine must be cold and not running. Remove tether cord cap (DESS key) before performing any maintenance or adjustment, unless otherwise specified. Vehicle must be parked in a safe place, away from the trail.

WARNING

Observe WARNINGS and CAUTIONS mentioned throughout this guide which are relevant to the item being checked. When component conditions seem less than satisfactory, replace with genuine BRP parts or approved equivalents.

Some items may not apply to your particular model. Refer to *MAINTENANCE* in *SHOP MANUAL* for more details.

2-Stroke

2-STROKE PERIODIC MAINTENANCE CHART									
A: ADJUST C: CLEAN I: INSPECT L: LUBRICATE R: REPLACE T: PROCEED WITH TASK *: TO BE PERFORMED BY AN AUTHORIZED SKI-DOO DEALER	* 10-HOUR OR 500 km (300 mi)								
	WEEKLY OR EVERY 240 km (150 mi)								
	MONTHLY OR EVERY 800 km (500 mi)								
	EVERY YEAR OR 3200 km (2000 mi)								
	EVERY 2 YEARS OR 6000 km (3700 mi)								
	* STORAGE								
* PRESEASON									
PART/TASK	LEGEND								
ENGINE									
Rewind starter and rope									I,L,C
Engine support	I			I		I			
Exhaust system ⁽³⁾	I		I			I			
Exhaust manifold screws	I								I
Axial fan condition (fan cooled models)									I
Engine lubrication							T		
Cooling system cap, hoses and clamps (liquid cooled models)	I			I					I
Coolant (liquid cooled models)	I				R				
Crankshaft PTO seals ⁽³⁾						I			
RAVE valves ⁽³⁾ (600 engine only)				C					
RAVE valves solenoid (SDI engine)				I					
Injection oil filter			I				R		
Oil injection pump	A			A					A
Rags installation/removal in air intake and exhaust system							T	T	
FUEL SYSTEM									
Add fuel stabilizer							T		
Fuel filter					R				
Fuel lines and connections	I								I
Fuel rail (SDI engine only)	I								I
Carburetor (except SDI engine)	A			A					A,C
Throttle cable	I			I					I
Air filter ⁽³⁾			C						C

(3) Emission-related.

(3) Emission-related.

2-STROKE PERIODIC MAINTENANCE CHART

A: ADJUST
 C: CLEAN
 I: INSPECT
 L: LUBRICATE
 R: REPLACE
 T: PROCEED WITH TASK

*: TO BE PERFORMED BY AN AUTHORIZED SKI-DOO DEALER

* 10-HOUR OR 500 km (300 mi)

WEEKLY OR EVERY 240 km (150 mi)

MONTHLY OR EVERY 800 km (500 mi)

EVERY YEAR OR 3200 km (2000 mi)

EVERY 2 YEARS OR 6000 km (3700 mi)

* STORAGE

* PRESEASON

PART/TASK

LEGEND

FUEL SYSTEM (cont'd)

Fuel injection system (visual inspection, SDI engine only)				I					(3) Emission-related.
Throttle body ⁽³⁾ (SDI engine only)								C	
Air intake system ⁽³⁾								I,C	

DRIVE SYSTEM

Drive belt condition	I	I						I	(2) Lubricate whenever the vehicle is used in wet conditions (wet snow, rain, puddles). (4) Replace gearbox oil once a year at storage or every 6000 km (3700 mi).
Drive belt height adjustment	EVERY BELT REPLACEMENT								
Drive and driven pulley	I		I	C			I	C	
Tightening torque of drive pulley screw	I			I				I	
Driven pulley preload	I			I				I	
Brake fluid	I	I				R		I	
Brake hose, pads and disk	I	I						I	
Gearbox oil	I		I				R ⁽⁴⁾	I	
Drive axle end bearing ⁽²⁾	L		L				L		
Track	I		I					I	
Track tension and alignment	A	AS REQUIRED							

STEERING/SUSPENSION

Steering and front suspension mechanism ⁽²⁾	A,I, L		A,I	L			A,I, L		(2) Lubricate whenever the vehicle is used in wet conditions (wet snow, rain, puddles).
Wear and condition of skis and runners	I	I					I		

SUSPENSION

Suspension adjustments	A	AS REQUIRED							(2) Lubricate whenever the vehicle is used in wet conditions (wet snow, rain, puddles).
Front and rear suspensions ⁽²⁾	I		I,L				I,L		
Rear suspension stopper strap				I			I		

2-STROKE PERIODIC MAINTENANCE CHART

A: ADJUST
 C: CLEAN
 I: INSPECT
 L: LUBRICATE
 R: REPLACE
 T: PROCEED WITH TASK

*: TO BE PERFORMED BY AN AUTHORIZED SKI-DOO DEALER

*** 10-HOUR OR 500 km (300 mi)**

WEEKLY OR EVERY 240 km (150 mi)

MONTHLY OR EVERY 800 km (500 mi)

EVERY YEAR OR 3200 km (2000 mi)

EVERY 2 YEARS OR 6000 km (3700 mi)

*** STORAGE**

*** PRESEASON**

PART/TASK

LEGEND

ELECTRICAL SYSTEM

EMS fault codes (SDI engine only)	I					I		(1) Before installing new spark plugs at preseason preparation, it is suggested to burn excess storage oil by starting the engine with the old spark plugs. Only perform this operation in a well ventilated area. (3) Emission-related.
Spark plugs ⁽¹⁾⁽³⁾	I		I				R	
Battery (if so equipped)	I		I			I	I	
Wiring harnesses and cables ⁽³⁾	I		I			I		
Operation of lighting system (HI/LO beam, brake light, etc.), test operation of engine cut-out switch and tether engine cut-out switch	I	I				I		

VEHICLE

Headlamp beam aiming				A				—
Engine compartment	C		C			C		
Vehicle cleaning and protection	T		T			T		

4-Stroke

4-STROKE PERIODIC MAINTENANCE CHART

A: ADJUST
 C: CLEAN
 I: INSPECT
 L: LUBRICATE
 R: REPLACE
 T: PROCEED WITH TASK

*: TO BE PERFORMED BY AN AUTHORIZED SKI-DOO DEALER

* 10-HOUR OR 500 km (300 mi)

WEEKLY OR EVERY 240 km (150 mi)

MONTHLY OR EVERY 800 km (500 mi)

EVERY YEAR OR 3200 km (2000 mi)

EVERY 2 YEARS OR 6000 km (3700 mi)

* STORAGE

* PRESEASON

PART/TASK

LEGEND

ENGINE

Engine oil level	EVERY RIDE					
Engine motor mounts	I			I		I
Engine seals						I
Exhaust system ⁽³⁾	I		I			I
Engine lubrication						T
Cooling system cap, hoses and clamps	I			I		I
Coolant	I				R	
Engine oil and filter	R			R		
Valve adjustment	I,T			I,T		
Rags installation/removal in air intake and exhaust system						T T

(3) Emission-related.

FUEL SYSTEM

Add fuel stabilizer						T
Fuel filter					R	
Fuel lines and connections	I					I
Throttle cable	I			I		I
Air filter ⁽³⁾			C			C
Throttle body ⁽³⁾						C
Air intake system ⁽³⁾						I,C

(3) Emission-related.

4-STROKE PERIODIC MAINTENANCE CHART

A: ADJUST
 C: CLEAN
 I: INSPECT
 L: LUBRICATE
 R: REPLACE
 T: PROCEED WITH TASK

*: TO BE PERFORMED BY AN
 AUTHORIZED SKI-DOO DEALER

* 10-HOUR OR 500 km (300 mi)

WEEKLY OR EVERY 240 km (150 mi)

MONTHLY OR EVERY 800 km (500 mi)

EVERY YEAR OR 3200 km (2000 mi)

EVERY 2 YEARS OR 6000 km (3700 mi)

* STORAGE

* PRESEASON

PART/TASK

LEGEND

DRIVE SYSTEM

Drive belt condition	I	I					I	(2) Lubricate whenever the vehicle is used in wet conditions (wet snow, rain, puddles). (4) Replace gearbox oil once a year at storage or every 6000 km (3700 mi).
Drive belt height adjustment	EVERY BELT REPLACEMENT							
Drive and driven pulley	I		I	C		I	C	
Tightening torque of drive pulley screw	I			I			I	
Driven pulley preload	I			I			I	
Brake fluid	I	I			R		I	
Brake hose, pads and disk	I	I					I	
Gearbox oil	I		I			R ⁽⁴⁾	I	
Drive axle end bearing ⁽²⁾	L		L			L		
Track	I	I					I	
Track tension and alignment	A	AS REQUIRED						

STEERING/FRONT SUSPENSION

Steering and front suspension mechanism ⁽²⁾	A,I, L		A,I	L		A,I, L		(2) Lubricate whenever the vehicle is used in wet conditions (wet snow, rain, puddles).
Wear and condition of skis and runners	I	I				I		

SUSPENSION

Suspension adjustments	A	AS REQUIRED						(2) Lubricate whenever the vehicle is used in wet conditions (wet snow, rain, puddles).
Front and rear suspensions ⁽²⁾	I		I,L			I,L		
Rear suspension stopper strap				I		I		

4-STROKE PERIODIC MAINTENANCE CHART

<p>A: ADJUST C: CLEAN I: INSPECT L: LUBRICATE R: REPLACE T: PROCEED WITH TASK</p> <p>*: TO BE PERFORMED BY AN AUTHORIZED SKI-DOO DEALER</p>	<p>* 10-HOUR OR 500 km (300 mi)</p> <p>WEEKLY OR EVERY 240 km (150 mi)</p> <p>MONTHLY OR EVERY 800 km (500 mi)</p> <p>EVERY YEAR OR 3200 km (2000 mi)</p> <p>EVERY 2 YEARS OR 6000 km (3700 mi)</p> <p>* STORAGE</p> <p>* PRESEASON</p>
PART/TASK	LEGEND

ELECTRICAL SYSTEM

EMS fault codes ⁽³⁾	I	I	I	I	I	I	<p>(1) Before installing new spark plugs at pre-season preparation, it is suggested to burn excess storage oil by starting the engine with the old spark plugs. Only perform this operation in a well ventilated area.</p> <p>(3) Emission-related.</p>
Spark plugs ⁽¹⁾⁽³⁾	I	I	I	R	I	I	
Battery	I	I	I	I	I	I	
Wiring harnesses and cables ⁽³⁾	I	I	I	I	I	I	
Operation of lighting system (HI/LO beam, brake light, etc.), test operation of engine cut-out switch and tether engine cut-out switch	I	I	I	I	I	I	

VEHICLE

Headlamp beam aiming	I	I	A	I	I	I	—
Engine compartment	C	C	C	C	C	C	
Vehicle cleaning and protection	T	T	T	T	T	T	

ENGINE SYSTEM

Air Filter Cleaning

All Models except V800

Remove filter from air inlet duct. Shake the snow out of filter, then, dry it out.



1. Air filter installed in air inlet duct

Open hood and make sure the filter on air silencer is free of snow.



1. Air filter installed on top of air silencer

V800 Model



1. Air filter
2. Air silencer

All Models

Check that the air silencer is clean and dry and properly reinstall the filter.

CAUTION: Snowmobile engines have been calibrated with the filter installed. Operating the snowmobile without it may cause engine damage.

Cooling System

CAUTION: Vehicle must be on a level surface before checking any fluid levels.

Liquid Cooled Models Only

Check coolant level at room temperature. Liquid should be at COLD LEVEL line (engine cold) of coolant tank.

NOTE: When checking level at low temperature it may be slightly lower than the mark.

If additional coolant is necessary or if entire system has to be refilled, refer to an authorized SKI-DOO dealer.



SKANDIC WT 600/SUV 600
1. COLD LEVEL line



EXPEDITION TUV 600 HO SDI —
EXPANSION RESERVOIR NEAR INJECTION
OIL RESERVOIR
1. Maximum

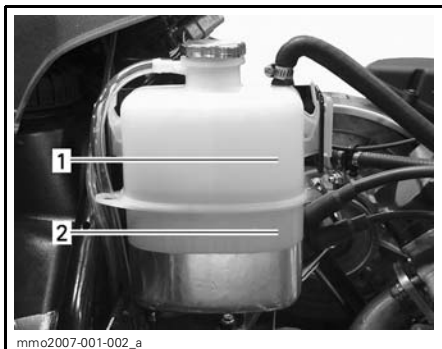

EXPEDITION TUV V800/SKANDIC SWT V800
— EXPANSION RESERVOIR NEAR MUFFLER
1. Maximum
2. Minimum

Exhaust System

The tail pipe of the muffler should be centered with the exit hole in the bottom pan. It must be free of rust or leaks. Make sure that gear clamps are properly tightened.

The exhaust system is designed to reduce noise and to improve the total performance of the engine. Modification may be in violation of local laws.

CAUTION: If any exhaust system component is removed, modified or damaged, severe engine damage may result.

Injection Oil Level (2-stroke engines)

CAUTION: Vehicle must be on a level surface before checking any fluid levels.

Always maintain a sufficient amount of recommended injection oil in the injection oil reservoir.

CAUTION: Never allow oil reservoir to be almost empty.

WARNING

Check level and refill every time you refuel. Do not overfill. Wipe off any spillage. Oil is highly flammable when heated.

Skandic WT 550F/SWT 550F

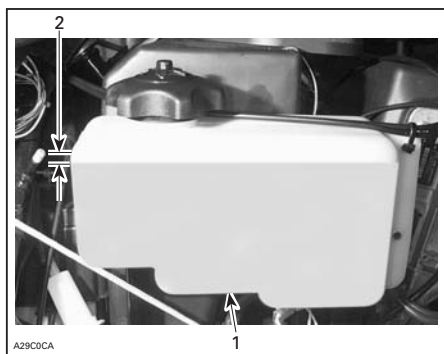

TYPICAL

1. Injection oil reservoir
2. Maximum level: 13 mm (1/2 in) from top

Skandic WT 600/SUV 550F

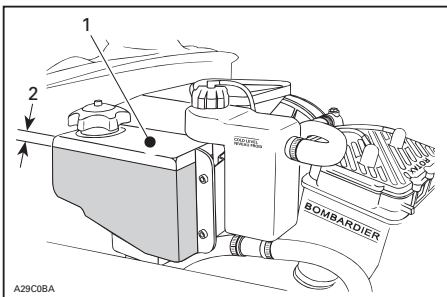

1. Injection oil reservoir
2. Maximum level: 13 mm (1/2 in) from top

Expedition TUV 600 HO SDI/ SUV 600 HO SDI



1. Injection oil reservoir

Engine Oil Level (4-stroke engines)

V800 Model

CAUTION: Check level frequently and refill if necessary. **Do not overfill.** Operating the engine with an improper level may severely damage engine. Wipe off any spillage.

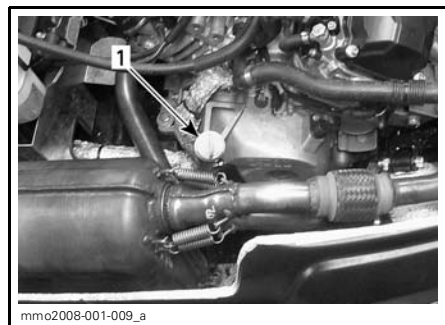

RH SIDE OF ENGINE COMPARTMENT

1. Dipstick

Make sure engine is at operating temperature.

Snowmobile must be on a level surface.

Let engine running at idle for at least 30 seconds.

Remove and wipe the dipstick.

Reinstall dipstick.

Remove and check oil level. Oil level must be between minimum and maximum marks on dipstick.

There is a capacity of 500 mL (17 U.S. oz) between the two marks.

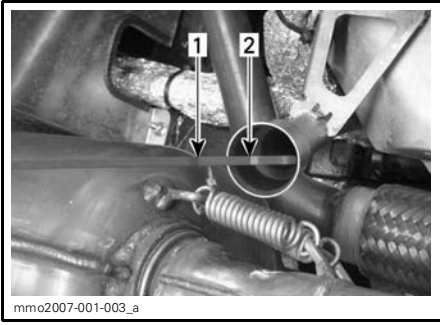

1. *Maximum*
2. *Minimum*

To add oil, remove dipstick. Place a funnel into the dipstick tube to avoid spillage.

Add a small amount of recommended oil and recheck oil level.

Repeat the above procedures until oil level reaches the dipstick's upper mark. **Do not overfill.**

Properly reinstall dipstick.

EPA Certified Engines

Maintenance, replacement, or repair of the emission control devices and systems may be performed by any snowmobile SI (spark ignition) engine repair establishments or individual.

Engine Emissions Information

Manufacturer's Responsibility

Snowmobile manufacturers of snowmobile engines need to determine the exhaust emission levels for each engine horsepower family and certify these engines with the United States of America Environmental Protection Agency (EPA). An emissions control information label, showing emission levels and engine specifications, must be placed on each vehicle at the time of manufacture.

Dealer's Responsibility

When performing service on a certified SKI-DOO snowmobiles that carry an emissions control information label, adjustments must be kept within published factory specifications.

Replacement or repair of any emission related component must be executed in a manner that maintains emission levels within the prescribed certification standards.

Dealers are not to modify the engine in any manner that would alter the horsepower or allow emission levels to exceed their predetermined factory specifications.

Exceptions include manufacturer's prescribed changes, such as altitude adjustments for example.

Owner Responsibility

The owner/operator is required to have engine maintenance performed to maintain emission levels within prescribed certification standards.

The owner/operator is not to, and should not allow anyone to modify the engine in any manner that would alter the horsepower or allow emissions levels to exceed their predetermined factory specifications.

EPA Emission Regulations

All new SKI-DOO snowmobiles manufactured by BRP are certified to the EPA as conforming to the requirements of the regulations for the control of air pollution from new snowmobile engines. This certification is contingent on certain adjustments being set to factory standards. For this reason, the factory procedure for servicing the product must be strictly followed and, whenever practicable, returned to the original intent of the design.

The responsibilities listed above are general and in no way a complete listing of the rules and regulations pertaining to the EPA requirements on exhaust emissions for snowmobile products. For more detailed information on this subject, you may contact the following locations:

REGULAR U.S. POSTAL MAIL:

1200 Pennsylvania Ave. NW
Mail Code 6403J
Washington, DC 20460

FOR ALL COURIER SERVICES:

U.S. Environmental Protection
Agency
Office of Transportation and Air
Quality
1310 L Street NW
Washington, DC 20005

INTERNET:

<http://www.epa.gov/otaq/>

E-MAIL:

otaqpublicweb@epa.gov

DRIVE SYSTEM

Brake Fluid Level

CAUTION: Vehicle must be on a level surface before checking any fluid levels.

Check brake fluid (DOT 4) in reservoir for proper level. Add fluid (DOT 4) as required.

CAUTION: Use only DOT 4 brake fluid from a sealed container. Never use any other types of fluid.

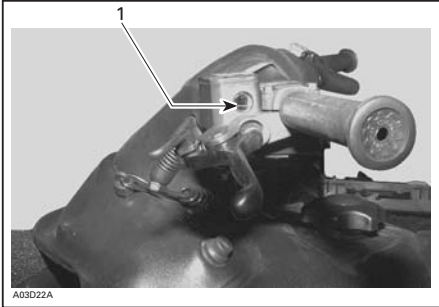

TYPICAL — BRAKE FLUID RESERVOIR
1. Minimum

Brake Condition

⚠ WARNING

The brake mechanism on your snowmobile is an essential safety device. Keep this mechanism in proper working condition. Above all, do not operate the snowmobile without an effective brake system. Periodically verify the condition/wear of the brake pads.

Brake Adjustment

No adjustment is provided for hydraulic brake. See an authorized SKI-DOO dealer if any problems.

Gearbox Oil Level

To check, pull dipstick. Oil should reach level mark.

NOTE: Before initial start-up, the oil level may be higher than the full mark. After first outing, oil level will decrease as the upper oil cavity fills with oil.

To fill, remove filler plug from top of gearbox. Refill as required using XP-S synthetic chaincase oil (P/N 413 803 300).

CAUTION: Do not use other unrecommended types of oil when servicing. Do not mix this synthetic oil with other types of oil.

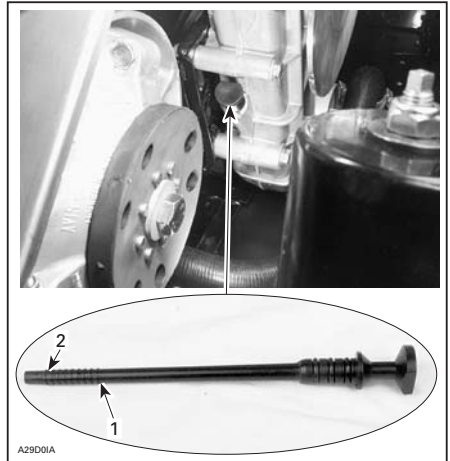

TYPICAL
1. Full level mark
2. Lower level mark

Belt Guard Removal and Installation

⚠ WARNING

Never operate engine:

- without shields and belt guard securely installed
- with hood and/or side panels opened or removed.

Never attempt to make adjustments to moving parts while engine is running.

2-Stroke Model

- Remove tether cord cap (DESS key).
- Open hood. Remove both retaining pins, then belt guard.

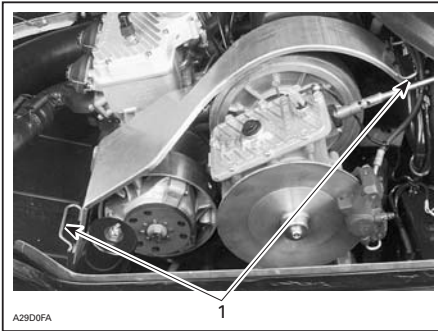

TYPICAL

1. Retaining pins

4-Stroke Model

- Remove tether cord cap (DESS key). Open engine compartment.
- Loosen collar screw on air silencer grommet.
- Disconnect engine vent hose from air silencer.
- Unhook latch from air silencer. Remove air silencer.

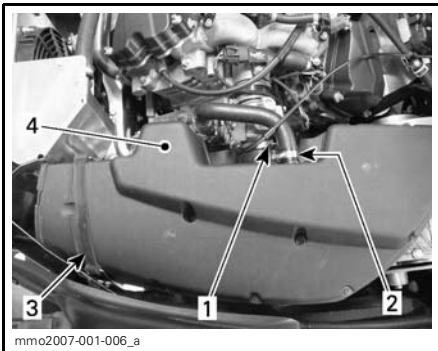

1. Collar screw
2. Vent hose
3. Latch
4. Air silencer

All Models

When reinstalling belt guard, make sure to reinstall retaining device(s).

NOTE: Belt guards are purposely made slightly oversize to maintain tension on their pins and retainers preventing undue noise and vibration. It is important that this tension be maintained when reinstalling.

Drive Belt Condition

Inspect belt for cracks, fraying or abnormal wear (uneven wear, wear on one side, missing cogs, cracked fabric). If abnormal wear is noted, probable cause could be pulley misalignment, excessive RPM with frozen track, fast starts without warm-up period, burred or rusty sheave, oil on belt or distorted spare belt. Contact an authorized SKI-DOO dealer.

Drive Belt Removal/Installation

WARNING

Remove tether cord cap (DESS key) before performing any maintenance or adjustment, unless otherwise specified. Vehicle must be parked in a safe place, away from the trail.

Removal

NOTE: Removal and installation of drive belt is easier when driven pulley is held with brake so that it can not rotate. Apply parking brake, for this purpose.

Remove tether cord cap (DESS key). Open hood and remove belt guard.

Push on drive belt between pulleys to open driven pulley.

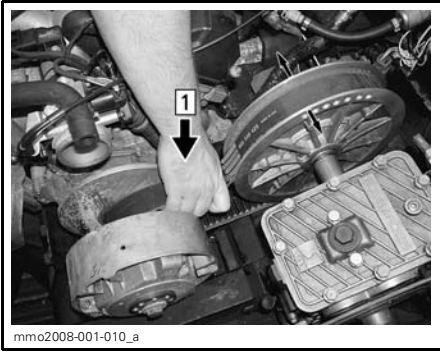

TYPICAL

Step 1: Push on drive belt

Release parking brake.

Slip the belt over the top edge of the sliding half while turning driven pulley, as shown.

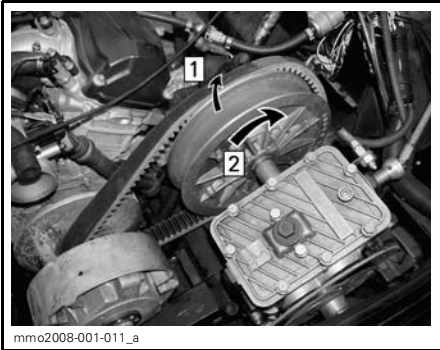

TYPICAL

Step 1: Slip the belt over the top edge of the sliding half

Step 2: Turn driven pulley at the same time

Remove drive belt.

Installation

To install the drive belt, reverse the removal procedure, however pay attention to the following.

The maximum drive belt life span is obtained when the belt has the proper rotation direction. Install it so the arrow printed on belt is pointing at front of vehicle.



TYPICAL

1. Arrow pointing at the front of vehicle

CAUTION: Do not force or use tools to pry the belt into place, as this could cut or break the cords in the belt.

Clean sheaves of both pulleys using Pulley flange cleaner (P/N 413 711 809).

Drive Belt Height Adjustment

To obtain maximum vehicle performance and drive belt longevity, drive belt height adjustment must be performed every time a new drive belt is installed.

NOTE: If correct adjustment is unattainable, contact an authorized SKI-DOO dealer.

The drive belt cord should be flush with driven pulley edge. Adjust as required.

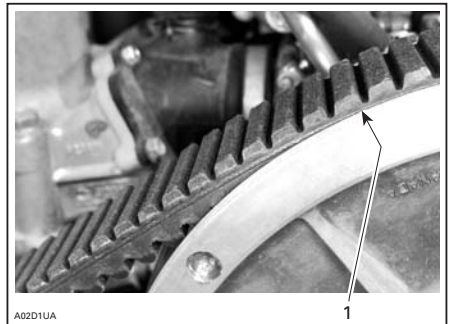

TYPICAL

1. Flush

Adjust drive belt height using Allen screws. Loosen jam nuts then turn Allen screws.

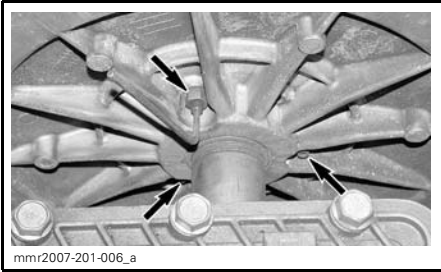

- To lower belt in driven pulley: turn Allen screws clockwise.
- To raise belt in driven pulley: turn Allen screws counterclockwise.

NOTE: Turn Allen screws 1/4 turn at a time, then rotate driven pulley to allow drive belt to settle in pulley. Check height, repeat as required.

NOTE: Allen screws must be restrained while tightening jam nut to prevent throwing adjustment out.

Drive Pulley Adjustment

WARNING

Remove tether cord cap (DESS key) before performing any maintenance or adjustment, unless otherwise specified. Vehicle must be parked in a safe place, away from the trail.

The drive pulley is factory calibrated to transmit maximum engine power at a predefined RPM. Factors such as ambient temperature, altitude or surface condition may vary this critical engine RPM thus affecting snowmobile efficiency.

This adjustable drive pulley allows setting maximum engine RPM to maintain maximum power.

Calibration screws should be adjusted so that actual maximum engine RPM matches the maximum horsepower RPM.

ENGINE	MAXIMUM HORSEPOWER RPM
550F	6900 RPM (± 100)
600	7000 RPM (± 100)
600 HO SDI	8000 RPM (± 100)
V800	7250 RPM (± 100)

NOTE: Use precision digital tachometer for engine RPM adjustment.

NOTE: The adjustment has an effect on high RPM only.

To adjust, turn calibration screws.

Calibration screw has a notch on top of its head.

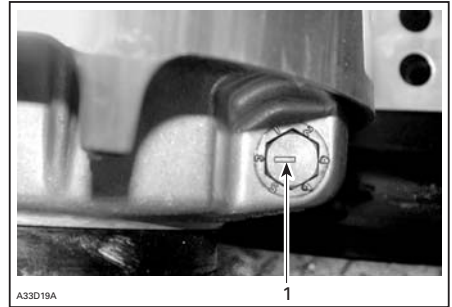

TYPICAL
1. Notch

There are 6 positions numbered 1 to 6. On TRA drive pulley, note that in position 1 the number is substituted by a dot (due to its location on casting).

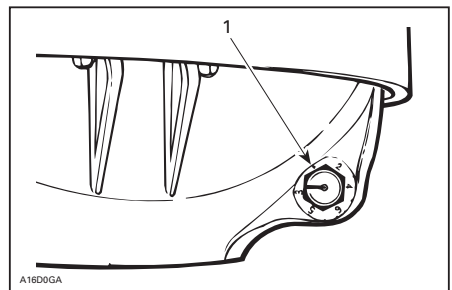

TYPICAL — TRA DRIVE PULLEY
1. Position 1 (not numbered)

Each position modifies maximum engine RPM by about 200 RPM.

Lower position numbers decrease engine RPM in steps of 200 RPM and higher position numbers increase it in steps of 200 RPM.

Example:

Calibration screw is set at position 4 and is changed to position 6. So maximum engine RPM is increased by 400 RPM.

Adjustment

Just loosen locking nut enough to pull calibration screw partially out and adjust to desired position. Do not completely remove the locking nut. Torque locking nuts to 10 N•m (89 lbf•in).

CAUTION: Do not completely remove calibration screw otherwise internal washers will fall off. Always adjust all 3 calibration screws and make sure they are all set to the same position.

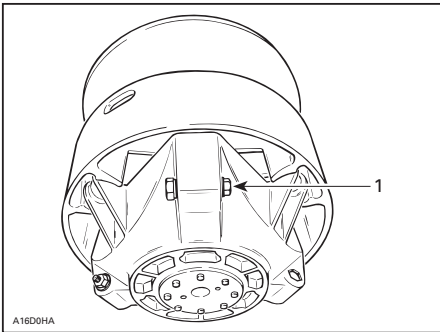

TYPICAL

1. Loosen just enough to permit rotating of calibrate screw

WARNING

NEVER disassemble or modify the drive pulley. Improper assembly or modifications could cause the pulley to explode violently under the stress generated by the high rotational speed. This could lead to serious injury including the possibility of death. See your SKI-DOO dealer for maintenance or service of the drive pulley. Improper servicing or maintenance may affect performance and reduce belt life. Always respect maintenance schedules.

WARNING

NEVER operate engine:

- without shields and belt guard securely installed
- with hood and/or side panels opened or removed.

NEVER attempt to make adjustments to moving parts while engine is running.

Track Condition

WARNING

Remove tether cord cap (DESS key) before performing any maintenance or adjustment, unless otherwise specified. Vehicle must be parked in a safe place, away from the trail.

Remove tether cord cap (DESS key).

Lift the rear of the snowmobile and support it with a wide-base snowmobile mechanical stand equipped with a protector back panel. With the engine off, rotate the track by hand, and inspect condition. If worn or cut, or if track fibers are exposed, or if missing or defective inserts or guides are noted; contact an authorized SKI-DOO dealer.

WARNING

Do not modify track, including the installation of traction enhancing products. At speed it may cause the track to tear and separate from vehicle posing a risk of severe injury or death. Do not operate or rotate a track if torn, damaged or excessively worn (fibers showing).

Track Adjustments

NOTE: Track tension and alignment are inter-related. Do not adjust one without the other.

WARNING

- Never stand behind or near a rotating track.
- Never spin the track at high speed whenever off the ground. Broken track or debris could be projected with great force which could sever legs or cause other serious injuries.

Tension

NOTE: Ride the snowmobile in snow about 15 to 20 minutes prior to adjusting track tension.

Remove the tether cord cap (DESS key).

Lift rear of snowmobile and support it with a wide-base snowmobile mechanical stand equipped with a protector back panel.

Allow the suspension to extend normally and check gap half-way between front and rear idler wheels. Measure between slider shoe bottom and inside of track. The gap should be as given in *SPECIFICATIONS* at the end of this guide. If the track tension is too loose, track will have a tendency to thump.

NOTE: A belt tension tester (P/N 414 348 200) may be used to measure deflection as well as force applied.

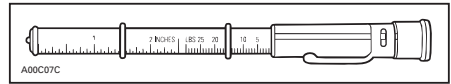

BELT TENSION TESTER

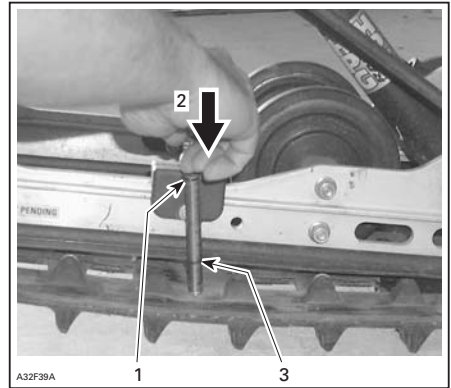

TYPICAL

1. Top tool O-ring positioned at 7.3 kg (16 lb)
2. Push on top portion of tool until it contacts the top O-ring
3. Measured track deflection

CAUTION: Too much tension will result in power loss and excessive stresses on suspension components.

To Adjust Track Tension:

- Remove the tether cord cap (DESS key).
- Loosen the rear idler wheel retaining screws.
- Loosen the lock nuts (on so equipped models), then turn adjustment screws to adjust.

If correct tension is unattainable, contact an authorized SKI-DOO dealer.

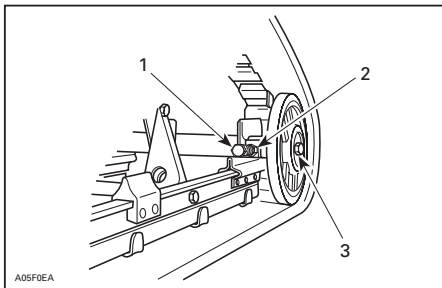

TYPICAL

1. Adjustment screw
2. Loosen lock nut (on so equipped models)
3. Loosen screw

- Retighten retaining screws and lock nuts (on so equipped models).
- Check track alignment as described below.

Alignment

⚠ WARNING

Before checking track alignment, ensure that the track is free of all particles which could be thrown out while track is rotating. Use a wide-based snowmobile mechanical stand equipped with a protector back panel. Keep hands, tools, feet and clothing clear of track. Ensure no one is standing in close proximity to the snowmobile, especially at the rear of the track. Never rotate track at high speed.

Start the engine and accelerate slightly so that track barely turns. This must be done in a short period of time (15 to 20 seconds).

Check that the track is well centered; equal distance on both sides between edges of track guides and slider shoes.

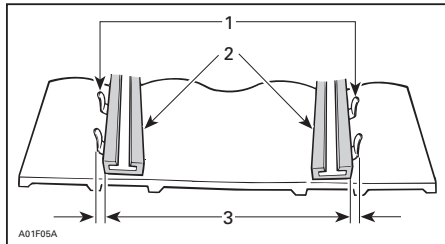

1. Guides
2. Slider shoes
3. Equal distance

To Adjust Track Alignment:

⚠ WARNING

Remove tether cord cap (DESS key) before performing any maintenance or adjustment, unless otherwise specified. Vehicle must be parked in a safe place, away from the trail.

- Remove the tether cord cap (DESS key).
- Loosen rear idler wheel retaining screws.
- Loosen the lock nuts (on so equipped models).
- Tighten the adjustment screw on side where the slider shoe is the farthest from the track insert guides.

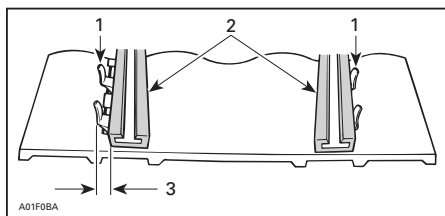

1. Guides
2. Slider shoes
3. Tighten on this side

Tighten lock nuts (some models only) and retaining screws.

⚠ WARNING

If lock nuts are not tightened properly, the adjusting screws could loosen causing the track to become extremely loose and, under some operating conditions, allow the idler wheels to climb over the track lugs forcing the track against the tunnel causing the track to "lock". Properly tighten wheel retaining screws, otherwise wheel may come off and cause track to "lock".

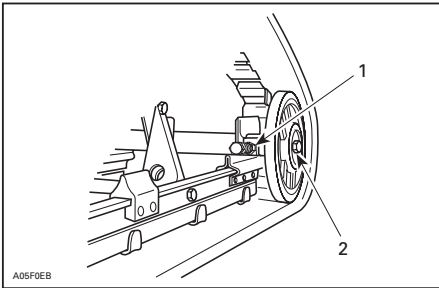

TYPICAL

1. Retighten (so equipped models)
2. Retighten to 48 N•m (35 lb•ft)

Restart engine and rotate track slowly to recheck alignment.

Reposition snowmobile on ground.

ELECTRICAL SYSTEM

Battery Electrolyte

These vehicles are equipped with a maintenance-free battery. Electrolyte level can not be checked.

 **WARNING**

BLACK negative battery cable must always be disconnected first and connected last.

 **WARNING**

Never charge or boost battery while installed. Battery electrolyte contains sulfuric acid which is corrosive and poisonous. In case of contact with skin, flush with water and call a physician immediately.

 **WARNING**

Should the battery casing be damaged, wear a suitable pair of non-absorbent gloves when removing the battery by hand.

CAUTION: Should any electrolyte spillage occur, immediately wash off with a solution of baking soda and water to prevent damage to vehicle components.

REAR SUSPENSION

Suspension Condition

Visually inspect all suspension components including slider shoes, springs, wheels, etc.

NOTE: During normal driving, snow will act as a lubricant and coolant for the slider shoes. Extensive riding on ice or sanded snow, will create excessive heat build-up and cause premature slider shoe wear.

Suspension Stopper Strap Condition

Inspect stopper strap for wear and cracks, bolt and nut for tightness. If loose inspect holes for deformation. Replace as required. Torque nut to 9 N•m (80 lbf•in).

STEERING AND FRONT SUSPENSION

Visually inspect steering and front suspension for tightness of components (steering arms, control arms and links, tie rods, ball joints, ski bolts, ski legs, etc.). If necessary, contact an authorized SKI-DOO dealer.

Wear and Condition of Skis and Runners

Check the condition of the skis, ski runners and ski runner carbides. If worn, contact an authorized SKI-DOO dealer.

 **WARNING**

Excessively worn skis and/or ski runners will adversely affect snowmobile control.

BODY/FRAME

Vehicle Cleaning and Protection

Remove any dirt or rust.

To clean the entire vehicle, use only flannel cloths or equivalent.

CAUTION: It is necessary to use flannel cloths or equivalent on windshield and hood to avoid damaging further surfaces to clean.

To remove grease, oil and grime, use Heavy duty cleaner (P/N 293 110 001) (spray can 400 g) and (P/N 293 110 002) (4 L).

CAUTION: Do not use Heavy duty cleaner on decals or vinyl.

To remove stubborn dirt from all plastic and vinyl surfaces, use Vinyl & Plastic Cleaner (P/N 413 711 200) (6 x 1 L).

To remove scratches on windshield or hood use Scratch Remover Kit (P/N 861 774 800).

CAUTION: Never clean plastic parts or hood with strong detergent, degreasing agent, paint thinner, acetone, products containing chlorine, etc.

Clean sheaves of both pulleys using Pulley flange cleaner (P/N 413 711 809).

Inspect the hood and repair any damage.

Touch up all metal spots where paint has been scratched off. Spray all metal parts including shock chromed rods with XP-S Lube (P/N 293 600 016).

Wax painted portion of the vehicle for better protection.

NOTE: Apply wax on glossy finish only. Protect the vehicle with a cover to prevent dust accumulation during storage.

CAUTION: The snowmobile has to be stored in a cool and dry place and covered with an opaque tarpaulin. This will prevent sun rays and grime from affecting plastic components and vehicle finish.

Lift rear of vehicle until track is clear of the ground. Install on a wide-base snowmobile mechanical stand.

WARNING

Do not attempt to lift the vehicle by hand alone. Use appropriate lifting device or have assistance to share lifting stress in order to avoid risk of strain injuries.

NOTE: Do not release track tension.

Bulb Replacement

Always check light operation after bulb replacement.

Headlamp

CAUTION: Never touch glass portion of an halogen bulb with bare fingers, it shortens its operating life. If glass is touched, clean it with isopropyl alcohol which will not leave a film on the bulb.

To replace a burnt headlamp bulb, remove the following:

- windshield assembly
- air intake dashboard cover.



Taillight

If taillight bulb is burnt, expose the bulb by removing the red plastic lens. To remove, unscrew the 2 lens screws.

STORAGE AND PRESEASON PREPARATION

WARNING

Have an authorized SKI-DOO dealer inspect fuel and oil systems integrity as specified in *PERIODIC MAINTENANCE CHART*.

Storage

It is during summer, or when a snowmobile is not in use for more than one month that proper storage is a necessity.

To prepare your snowmobile, refer to an authorized SKI-DOO dealer.

Engine Cooling System

Liquid Cooled Models

Antifreeze should be replaced for the storage period to prevent antifreeze deterioration.

The antifreeze replacement and a density test should be performed by an authorized SKI-DOO dealer.

CAUTION: Improper antifreeze mixture might allow freezing of the liquid in the cooling system if vehicle is stored in area where freezing point is reached. This would seriously damage the engine. Failure to replace the antifreeze for storage may cause its degradation which could result in poor cooling when engine will be used.

CAUTION: Do not run engine during storage period.

Preseason Preparation

Refer to an authorized SKI-DOO dealer.

CAUTION: Have carburetor(s) cleaned-up before restarting engine on so equipped models.

WARRANTY

BRP LIMITED WARRANTY NORTH AMERICA: 2008 SKI-DOO® SNOWMOBILES

1) SCOPE OF THE LIMITED WARRANTY

Bombardier Recreational Products Inc. ("BRP")* warrants its 2008 Ski-Doo snowmobiles sold by authorized BRP dealers (as hereinafter defined) in the fifty United States and Canada from defects in material or workmanship for the period and under the conditions described below.

All genuine Ski-Doo parts and accessories, installed by an authorized BRP dealer at the time of delivery of the 2008 Ski-Doo snowmobile, carry the same warranty as that of the snowmobile.

A GPS receiver may be supplied by BRP as standard equipment on certain 2008 Ski-Doo snowmobiles. The GPS receiver is covered by the limited warranty issued by the GPS receiver's manufacturer and is not covered by this BRP limited warranty.

Use of the product for racing or any other competitive activity, at any point, even by a previous owner, will render this warranty null and void.

2) EXCLUSIONS – ARE NOT WARRANTED

The following are not warranted under any circumstances:

- Normal wear and tear;
- Routine maintenance items, tune ups, adjustments;
- Damage caused by failure to provide proper maintenance and/or storage, as described in the Operator's Guide;
- Damage resulting from removal of parts, improper repairs, service, maintenance, modifications or use of parts not manufactured or approved by BRP or resulting from repairs done by a person that is not an authorized servicing BRP dealer;
- Damage caused by abuse, abnormal use, neglect, use of the product on surfaces other than snow, or operation of the product in a manner inconsistent with the recommended operation described in the Operator's Guide;
- Damage resulting from accident, submersion, fire, theft, vandalism or any act of God;
- Operation with fuels, oils or lubricants which are not suitable for use with the product (see the Operator's Guide);
- Snow or water ingestion;
- Incidental or consequential damages, or damages of any kind including without limitation towing, storage, telephone, rental, taxi, inconvenience, insurance coverage, loan payments, loss of time, loss of income; and
- Damage resulting from studs installed on tracks if the installation does not conform to BRP's instructions.

3) LIMITATIONS OF LIABILITY

THIS WARRANTY IS EXPRESSLY GIVEN AND ACCEPTED IN LIEU OF ANY AND ALL OTHER WARRANTIES, EXPRESSED OR IMPLIED, INCLUDING WITHOUT LIMITATION ANY WARRANTY OF MERCHANTABILITY OR FITNESS FOR A PARTICULAR PURPOSE. TO THE EXTENT THAT THEY CANNOT BE DISCLAIMED, THE IMPLIED WARRANTIES ARE LIMITED IN DURATION TO THE LIFE OF THE EXPRESS WARRANTY. INCIDENTAL AND CONSEQUENTIAL DAMAGES ARE EXCLUDED FROM COVERAGE UNDER THIS WARRANTY. SOME STATES/PROVINCES DO NOT ALLOW FOR THE DISCLAIMERS, LIMITATIONS AND EXCLUSIONS IDENTIFIED ABOVE, AS A RESULT, THEY MAY NOT APPLY TO YOU. THIS WARRANTY GIVES YOU SPECIFIC RIGHTS, AND YOU MAY ALSO HAVE OTHER LEGAL RIGHTS WHICH MAY VARY FROM STATE TO STATE, OR PROVINCE TO PROVINCE.

Neither the distributor, any BRP dealer nor any other person has been authorized to make any affirmation, representation or warranty regarding the product, other than those contained in this limited warranty, and if made, shall not be enforceable against BRP.

BRP reserves the right to modify this warranty at any time, being understood that such modification will not alter the warranty conditions applicable to the products sold while this warranty is in effect.

4) WARRANTY COVERAGE PERIOD

This warranty will be in effect from the date of delivery to the first retail consumer or the date the product is first put into use, whichever occurs first and for a period of:

TWELVE (12) CONSECUTIVE MONTHS, for private or commercial use owners. However, the warranty coverage period on a snowmobile delivered between June 1st and December 1st of a given year will expire December 1st of the following year.

The emission-related components included in the chart below, that are installed on EPA certified snowmobiles (see list below) registered in the USA are covered for thirty (30) consecutive months or 2500 miles (4000 km) of engine use whichever occurs first. If the 2500 miles (4000 km) are reached during the regular warranty coverage period, the emission-related components are still covered by BRP's standard warranty until the end of regular coverage period.

The EPA certified snowmobiles are those equipped with: 550 (fan cooled), 600, 600 HO SDI, 4-TEC V800 engines:

EMISSION-RELATED COMPONENTS	550 (fan cooled)	600	600 HO SDI	4-TEC V800
Rave Hose System			X	
Throttle Position Sensor (TPS)			X	X
Air Temperature Sensor (ATS)			X	X
Air Pressure Sensor (APS)			X	X
Knock Sensor			X	
Fuel Pressure Regulator			X	X
Fuel Injectors			X	X
Engine Control Module (ECM)			X	X
Throttle Body Shaft Seals				X
Muffler Temperature Sensor			X	
Carburetor	X	X		
Carburetor Air Intake Adapter	X	X	X	
Engine Air Intake Adapter/ Gasket				X
Reed Valve	X	X	X	
Temp and Manifold Sensor (TMAPS)				X

The repair or replacement of parts or the performance of service under this warranty does not extend the life of this warranty beyond its original expiration date.

5) CONDITIONS TO HAVE WARRANTY COVERAGE

This warranty coverage is available only if each of the following conditions has been fulfilled:

- The 2008 Ski-Doo snowmobile must be purchased as new and unused by its first owner from a BRP dealer authorized to distribute Ski-Doo snowmobiles in the country in which the sale occurred ("BRP dealer");
- The BRP specified pre-delivery inspection process must be completed and documented;
- The product must have undergone proper registration by an authorized BRP dealer;
- The 2008 Ski-Doo snowmobile must be purchased in the country in which the purchaser resides;
- Routine maintenance outlined in the Operator's Guide must be timely performed in order to maintain warranty coverage. BRP reserves the right to make warranty coverage contingent upon proof of proper maintenance.

BRP will not honour this limited warranty to any private use owner or commercial use owner if the preceding conditions have not been met. Such limitations are necessary in order to allow BRP to preserve both the safety of its products, and also that of its consumers and the general public.

6) WHAT TO DO TO OBTAIN WARRANTY COVERAGE

The customer must notify a servicing BRP dealer within two (2) days of the appearance of a defect, and provide it with reasonable access to the product and reasonable opportunity to repair it. The customer must also present to the authorized BRP dealer, proof of purchase of the product and must sign the repair/work order prior to starting the repair in order to validate the warranty repair. All parts replaced under this limited warranty become the property of BRP.

7) WHAT BRP WILL DO

BRP's obligations under this warranty are limited to, at its sole discretion, repairing parts found defective under normal use, maintenance and service, or replacing such parts with new genuine Ski-Doo parts without charge for parts and labor, at any authorized BRP dealer during the warranty coverage period.

BRP reserves the right to improve or modify products from time to time without assuming any obligation to modify products previously manufactured.

8) TRANSFER

If the ownership of a product is transferred during the warranty coverage period, this warranty shall also be transferred and be valid for the remaining coverage period provided that BRP is notified of such transfer of ownership in the following way:

- a) The former owner contacts BRP (at the phone number provided below) or an authorized BRP dealer and gives the coordinates of the new owner; or
- b) BRP or an authorized BRP dealer receives a proof that the former owner agreed to the transfer of ownership, in addition to the coordinates of the new owner.

9) CONSUMER ASSISTANCE

- a) In the event of a controversy or a dispute in connection with this limited warranty, BRP suggests that you try to resolve the issue at the dealership level. We recommend discussing the issue with the authorized dealer's service manager or owner.
- b) If the issue has not yet been resolved, please submit your complaint in writing or call the appropriate number below:

In Canada

BOMBARDIER RECREATIONAL PRODUCTS INC.

Consumer Services Group
75, J.-A. Bombardier Street
Sherbrooke, Québec J1L 1W3
Tel.: 819 566-3366

In USA

BRP US INC.

Consumer Services Group
7575 Bombardier Court
Wausau WI 54401
Tel.: 715 848-4957

* In the USA, products are distributed and serviced by BRP US Inc.

© 2006 Bombardier Recreational Products Inc. All rights reserved.

® Registered trademark of Bombardier Recreational Products Inc.

BRP INTERNATIONAL LIMITED WARRANTY: 2008 SKI-DOO® SNOWMOBILES

1) SCOPE OF THE LIMITED WARRANTY

Bombardier Recreational Products Inc. ("BRP") warrants its 2008 Ski-Doo snowmobiles sold by authorized BRP distributor/dealer (as hereinafter defined) outside of the fifty United States, Canada and states members of the European Union from defects in material or workmanship for the period and under the conditions described below.

All genuine Ski-Doo parts and accessories, installed by an authorized BRP distributor/dealer at the time of delivery of the 2008 Ski-Doo snowmobile, carry the same warranty as that of the snowmobile.

A GPS receiver may be supplied by BRP as standard equipment on certain 2008 Ski-Doo snowmobiles. The GPS receiver is covered by the limited warranty issued by the GPS receiver's manufacturer and is not covered by this BRP limited warranty.

Use of the product for racing or any other competitive activity, at any point, even by a previous owner, will render this warranty null and void.

2) EXCLUSIONS – ARE NOT WARRANTED

The following are not warranted under any circumstances:

- Normal wear and tear;
- Routine maintenance items, tune ups, adjustments;
- Damage caused by failure to provide proper maintenance and/or storage, as described in the Operator's Guide;
- Damage resulting from removal of parts, improper repairs, service, maintenance, modifications or use of parts not manufactured or approved by BRP or resulting from repairs done by a person that is not an authorized servicing BRP distributor/dealer;
- Damage caused by abuse, abnormal use, neglect, use of the product on surfaces other than snow, or operation of the product in a manner inconsistent with the recommended operation described in the Operator's Guide;
- Damage resulting from accident, submersion, fire, theft, vandalism or any act of God;
- Operation with fuels, oils or lubricants which are not suitable for use with the product (see the Operator's Guide);
- Snow or water ingestion;
- Incidental or consequential damages, or damages of any kind including without limitation towing, storage, telephone, rental, taxi, inconvenience, insurance coverage, loan payments, loss of time, loss of income; and
- Damage resulting from studs installed on tracks if the installation does not conform to BRP's instructions.

3) LIMITATIONS OF LIABILITY

THIS WARRANTY IS EXPRESSLY GIVEN AND ACCEPTED IN LIEU OF ANY AND ALL OTHER WARRANTIES, EXPRESSED OR IMPLIED, INCLUDING WITHOUT LIMITATION ANY WARRANTY OF MERCHANTABILITY OR FITNESS FOR A PARTICULAR PURPOSE. TO THE EXTENT THAT THEY CANNOT BE DISCLAIMED, THE IMPLIED WARRANTIES ARE LIMITED IN DURATION TO THE LIFE OF THE EXPRESS WARRANTY. INCIDENTAL AND CONSEQUENTIAL DAMAGES ARE EXCLUDED FROM COVERAGE UNDER THIS WARRANTY. SOME STATES/PROVINCES DO NOT ALLOW FOR THE DISCLAIMERS, LIMITATIONS AND EXCLUSIONS IDENTIFIED ABOVE, AS A RESULT, THEY MAY NOT APPLY TO YOU. THIS WARRANTY GIVES YOU SPECIFIC RIGHTS, AND YOU MAY ALSO HAVE OTHER LEGAL RIGHTS WHICH MAY VARY FROM STATE TO STATE, OR PROVINCE TO PROVINCE.

Neither the distributor, any BRP distributor/dealer nor any other person has been authorized to make any affirmation, representation or warranty regarding the product, other than those contained in this limited warranty, and if made, shall not be enforceable against BRP.

BRP reserves the right to modify this warranty at any time, being understood that such modification will not alter the warranty conditions applicable to the products sold while this warranty is in effect.

4) WARRANTY COVERAGE PERIOD

This warranty will be in effect from the date of delivery to the first retail consumer or the date the product is first put into use, whichever occurs first and for a period of:

TWELVE (12) CONSECUTIVE MONTHS, for private or commercial use owners. However, the warranty coverage period on a snowmobile delivered between June 1st and December 1st of a given year will expire December 1st of the following year.

The repair or replacement of parts or the performance of service under this warranty does not extend the life of this warranty beyond its original expiration date.

Note that the duration and any other modalities of the warranty coverage are subject to the applicable national or local legislation in your country.

5) CONDITIONS TO HAVE WARRANTY COVERAGE

This warranty coverage is available only if each of the following conditions has been fulfilled:

- The 2008 Ski-Doo snowmobile must be purchased as new and unused by its first owner from a BRP distributor/dealer authorized to distribute Ski-Doo snowmobiles in the country in which the sale occurred (“BRP distributor/dealer”);
- The BRP specified pre-delivery inspection process must be completed and documented;
- The product must have undergone proper registration by an authorized BRP distributor/dealer;
- The 2008 Ski-Doo snowmobile must be purchased in the country or union of countries in which the purchaser resides.

- Routine maintenance outlined in the Operator's Guide must be timely performed in order to maintain warranty coverage. BRP reserves the right to make warranty coverage contingent upon proof of proper maintenance.

BRP will not honour this limited warranty to any private use owner or commercial use owner if the preceding conditions have not been met. Such limitations are necessary in order to allow BRP to preserve both the safety of its products, and also that of its consumers and the general public.

6) WHAT TO DO TO OBTAIN WARRANTY COVERAGE

The customer must notify a servicing BRP distributor/dealer within two (2) days of the appearance of a defect, and provide it with reasonable access to the product and reasonable opportunity to repair it. The customer must also present to the authorized BRP distributor/dealer, proof of purchase of the product and must sign the repair/work order prior to starting the repair in order to validate the warranty repair. All parts replaced under this limited warranty become the property of BRP.

Note that the notification period is subject to the applicable national or local legislation in your country.

7) WHAT BRP WILL DO

BRP's obligations under this warranty are limited to, at its sole discretion, repairing parts found defective under normal use, maintenance and service, or replacing such parts with new genuine Ski-Doo parts without charge for parts and labor, at any authorized BRP distributor/dealer during the warranty coverage period.

BRP reserves the right to improve or modify products from time to time without assuming any obligation to modify products previously manufactured.

8) TRANSFER

If the ownership of a product is transferred during the warranty coverage period, this warranty shall also be transferred and be valid for the remaining coverage period provided BRP or an authorized BRP distributor/dealer receives a proof that the former owner agreed to the transfer of ownership, in addition to the coordinates of the new owner.

9) CONSUMER ASSISTANCE

- a) In the event of a controversy or a dispute in connection with this limited warranty, BRP suggests that you try to resolve the issue at the dealership level. We recommend discussing the issue with the authorized distributor/dealer's service manager or owner.
- b) If further assistance is required, the distributor's service department should be contacted in order to resolve the matter. You can find your distributor's coordinates on www.brp.com.
- c) If the matter still remains unresolved then contact BRP at the address listed below.

For Russia, CIS and the Middle East, please contact our European office:

BRP EUROPE N.V.

Consumer Services Group
Skaldenstraat 125
9042 Gent
Belgique
Tel.: + 32 9 218 26 00

For Scandinavia and European countries, please contact our Finland office:

BRP FINLAND OY

Service Department
Ahjotie 30
FIN-96320 Rovaniemi
Finland
Tel.: + 358 16 3208 111

For all other countries, please contact our North American office:

BOMBARDIER RECREATIONAL PRODUCTS INC.

Consumer Services Group
75, J.-A. Bombardier Street
Sherbrooke, Québec J1L 1W3
Tel.: 819 566-3366

© 2006 Bombardier Recreational Products Inc. All rights reserved.

® Registered trademark of Bombardier Recreational Products Inc.

BRP EUROPEAN UNION MEMBER STATES LIMITED WARRANTY: 2008 SKI-DOO® SNOWMOBILES

1) SCOPE OF THE LIMITED WARRANTY

Bombardier Recreational Products Inc. ("BRP")* warrants its 2008 Ski-Doo snowmobiles sold by authorized BRP distributor/dealer (as hereinafter defined) in states members of the European Union from defects in material or workmanship for the period and under the conditions described below.

All genuine Ski-Doo parts and accessories, installed by an authorized BRP distributor/dealer (at the time of delivery of the 2008 Ski-Doo snowmobile, carry the same warranty as that of the snowmobile.

A GPS receiver may be supplied by BRP as standard equipment on certain 2008 Ski-Doo snowmobiles. The GPS receiver is covered by the limited warranty issued by the GPS receiver's manufacturer and is not covered by this BRP limited warranty.

Use of the product for racing or any other competitive activity, at any point, even by a previous owner, will render this warranty null and void.

2) EXCLUSIONS – ARE NOT WARRANTED

The following are not warranted under any circumstances:

- Normal wear and tear;
- Routine maintenance items, tune ups, adjustments;
- Damage caused by failure to provide proper maintenance and/or storage, as described in the Operator's Guide;
- Damage resulting from removal of parts, improper repairs, service, maintenance, modifications or use of parts not manufactured or approved by BRP or resulting from repairs done by a person that is not an authorized servicing BRP distributor/dealer;
- Damage caused by abuse, abnormal use, neglect, use of the product on surfaces other than snow, or operation of the product in a manner inconsistent with the recommended operation described in the Operator's Guide;
- Damage resulting from accident, submersion, fire, theft, vandalism or any act of God;
- Operation with fuels, oils or lubricants which are not suitable for use with the product (see the Operator's Guide);
- Snow or water ingestion;
- Incidental or consequential damages, or damages of any kind including without limitation towing, storage, telephone, rental, taxi, inconvenience, insurance coverage, loan payments, loss of time, loss of income; and
- Damage resulting from studs installed on tracks if the installation does not conform to BRP's instructions.

3) LIMITATIONS OF LIABILITY

THIS WARRANTY IS EXPRESSLY GIVEN AND ACCEPTED IN LIEU OF ANY AND ALL OTHER WARRANTIES, EXPRESSED OR IMPLIED, INCLUDING WITHOUT LIMITATION ANY WARRANTY OF MERCHANTABILITY OR FITNESS FOR A PARTICULAR PURPOSE. TO THE EXTENT THAT THEY CANNOT BE DISCLAIMED, THE IMPLIED WARRANTIES ARE LIMITED IN DURATION TO THE LIFE OF THE EXPRESS WARRANTY. INCIDENTAL AND CONSEQUENTIAL DAMAGES ARE EXCLUDED FROM COVERAGE UNDER THIS WARRANTY. SOME JURISDICTIONS DO NOT ALLOW FOR THE DISCLAIMERS, LIMITATIONS AND EXCLUSIONS IDENTIFIED ABOVE, AS A RESULT, THEY MAY NOT APPLY TO YOU. THIS WARRANTY GIVES YOU SPECIFIC RIGHTS, AND YOU MAY ALSO HAVE OTHER LEGAL RIGHTS WHICH MAY VARY FROM COUNTRY TO COUNTRY, OR PROVINCE TO PROVINCE.

Neither the distributor, any BRP distributor/dealer nor any other person has been authorized to make any affirmation, representation or warranty regarding the product, other than those contained in this limited warranty, and if made, shall not be enforceable against BRP.

BRP reserves the right to modify this warranty at any time, being understood that such modification will not alter the warranty conditions applicable to the products sold while this warranty is in effect.

4) WARRANTY COVERAGE PERIOD

This warranty will be in effect from the date of delivery to the first retail consumer or the date the product is first put into use, whichever occurs first and for a period of:

TWENTY-FOUR (24) CONSECUTIVE MONTHS for private use owners, and TWELVE (12) CONSECUTIVE MONTHS for commercial use owners. However, the warranty coverage period on a snowmobile delivered between June 1st and December 1st of a given year will expire December 1st of the applicable year. A snowmobile is used commercially when it is used in connection with generating income or any work or employment during any part of the warranty period. A snowmobile is also used commercially when, at any point during the warranty period, it has commercial tags or is licensed for commercial use.

The repair or replacement of parts or the performance of service under this warranty does not extend the life of this warranty beyond its original expiration date.

Note that the duration and any other modalities of the warranty coverage are subject to the applicable national or local legislation in your country.

5) CONDITIONS TO HAVE WARRANTY COVERAGE

This warranty coverage is available only if each of the following conditions has been fulfilled:

- The 2008 Ski-Doo snowmobile must be purchased as new and unused by its first owner from a BRP distributor/dealer authorized to distribute Ski-Doo products in the country in which the sale occurred (“BRP distributor/dealer”);
- The BRP specified pre-delivery inspection process must be completed and documented;

- The product must have undergone proper registration by an authorized BRP distributor/dealer;
- the 2008 Ski-Doo snowmobile must be purchased in the country or union of countries in which the purchaser resides;
- Routine maintenance outlined in the Operator's Guide must be timely performed in order to maintain warranty coverage. BRP reserves the right to make warranty coverage contingent upon proof of proper maintenance.

BRP will not honour this limited warranty to any private use owner or commercial use owner if the preceding conditions have not been met. Such limitations are necessary in order to allow BRP to preserve both the safety of its products, and also that of its consumers and the general public.

6) WHAT TO DO TO OBTAIN WARRANTY COVERAGE

The customer must notify a servicing BRP distributor/dealer within two (2) months of the appearance of a defect, and provide it with reasonable access to the product and reasonable opportunity to repair it. The customer must also present to the authorized BRP distributor/dealer, proof of purchase of the product and must sign the repair/work order prior to starting the repair in order to validate the warranty repair. All parts replaced under this limited warranty become the property of BRP.

Note that the notification period is subject to the applicable national or local legislation in your country.

7) WHAT BRP WILL DO

BRP's obligations under this warranty are limited to, at its sole discretion, repairing parts found defective under normal use, maintenance and service, or replacing such parts with new genuine Ski-Doo parts without charge for parts and labor, at any authorized BRP distributor/dealer during the warranty coverage period.

BRP reserves the right to improve or modify products from time to time without assuming any obligation to modify products previously manufactured.

8) TRANSFER

If the ownership of a product is transferred during the warranty coverage period, this warranty shall also be transferred and be valid for the remaining coverage period provided BRP or an authorised BRP distributor/dealer receives a proof that the former owner agreed to the transfer of ownership, in addition to the coordinates of the new owner.

9) CONSUMER ASSISTANCE

- a) In the event of a controversy or a dispute in connection with this limited warranty, BRP suggests that you try to resolve the issue at the dealership level. We recommend discussing the issue with the authorized distributor/dealer's service manager or owner.
- b) If further assistance is required, the distributor's service department should be contacted in order to resolve the matter. You can find your distributor's coordinates on www.brp.com.
- c) If the matter still remains unresolved then contact BRP at the address listed below.

For Russia, CIS and the Middle East, please contact our European office:

BRP EUROPE N.V.

Consumer Services Group
Skaldenstraat 125
9042 Gent
Belgique
Tel.: + 32 9 218 26 00

For Scandinavia and European countries, please contact our Finland office:

BRP FINLAND OY

Service Department
Ahjotie 30
FIN-96320 Rovaniemi
Finland
Tel.: + 358 16 3208 111

For all other countries, please contact our North American office:

BOMBARDIER RECREATIONAL PRODUCTS INC.

Consumer Services Group
75, J.-A. Bombardier Street
Sherbrooke, Québec J1L 1W3
Tel.: 819 566-3366

PRIVACY OBLIGATIONS/DISCLAIMER

We wish to inform you that your coordinates will be used for safety and warranty purposes. Sometimes, we also use the coordinates of our clients to inform them about our products and to present them offers. Should you prefer not to receive information on our products, services and offers, please let us know by writing to the address below.

Also note that, from time to time, carefully selected and trustworthy organizations may be permitted to use the coordinates of our clients to promote quality products and services. If you prefer not to have your name and address released, please let us know by writing to the address below:

In Canada

BOMBARDIER RECREATIONAL PRODUCTS INC.

Warranty Department
75, J.-A. Bombardier Street
Sherbrooke, Québec J1L 1W3
Fax Number: 819 566-3590

In USA

BRP US INC.

Warranty Department
7575 Bombardier Court
Wausau WI 54401
Tel.: 715 848-4957

For Russia, CIS and the Middle East

BRP EUROPEAN DISTRIBUTION

After Sales Service Department
Chemin de Messidor 5-7
1006 Lausanne
Switzerland
Fax Number: + 41213187801

For Scandinavian and European countries

BRP FINLAND OY

Service Department
Ahjotie 30
FIN-96320 Rovaniemi
Finland
Tel.: + 358 16 3208 111

For all other countries, please contact A) or B)

A) Your respective distributor (you will find its coordinates on www.brp.com).

B) Our North American office:

BOMBARDIER RECREATIONAL PRODUCTS INC.

Warranty Department
75, J.-A. Bombardier Street
Sherbrooke, Québec J1L 1W3
Canada
Fax Number: 819 566-3590

CHANGE OF ADDRESS/OWNERSHIP

If your address has changed or if you are the new owner of the vehicle, be sure to notify BRP by either:

- mailing one of the following card below;
- **North America Only:** calling at 715 848-4957 (USA) or 819 566-3366 (Canada);
- notifying an authorized SKI-DOO dealer.

In North America

BOMBARDIER RECREATIONAL PRODUCTS INC.

Warranty Department
75, J.-A. Bombardier Street
Sherbrooke, Québec J1L 1W3
Fax Number: 819 566-3590

For Russia, CIS and the Middle East

BRP EUROPEAN DISTRIBUTION

After Sales Service Department
Chemin de Messidor 5-7
1006 Lausanne
Switzerland
Fax Number: + 41213187801

For Scandinavian and European countries

BRP FINLAND OY

Service Department
Ahjotie 30
FIN-96320 Rovaniemi
Finland
Tel.: + 358 16 3208 111

For all other countries, please contact A) or B)

A) Your respective distributor (you will find its coordinates on www.brp.com).

B) Our North American office:

BOMBARDIER RECREATIONAL PRODUCTS INC.

Warranty Department
75, J.-A. Bombardier Street
Sherbrooke, Québec J1L 1W3
Canada
Fax Number: 819 566-3590

In case of change of ownership, please join a proof that the former owner agreed to the transfer.

Notifying BRP, even after the expiration of the limited warranty, is very important as it enables BRP to reach the vehicle owner if necessary, like when safety recalls are initiated. It is the owner's responsibility to notify BRP.

STOLEN UNITS: If your personal vehicle is stolen, you should notify BRP or an authorized SKI-DOO dealer. We will ask you to provide your name, address, phone number, the vehicle identification number and the date it was stolen.



CHANGE OF ADDRESS <input type="checkbox"/>			CHANGE OF OWNERSHIP <input type="checkbox"/>		
VEHICLE IDENTIFICATION NUMBER					
<input type="text"/>		<input type="text"/>			
Model Number		Vehicle Identification Number (V.I.N.)			
OLD ADDRESS OR PREVIOUS OWNER:			NAME		
NO.		STREET		APT	
CITY		STATE/PROVINCE		ZIP/POSTAL CODE	
COUNTRY			TELEPHONE		
NEW ADDRESS OR NEW OWNER:			NAME		
NO.		STREET		APT	
CITY		STATE/PROVINCE		ZIP/POSTAL CODE	
COUNTRY			TELEPHONE		

V00A2F



520 000 745

CA

OPERATOR'S GUIDE, SKANDIC/WT/SWT/SUV, EXPEDITION TUV, ENGLISH
GUIDE DU CONDUCTEUR, SKANDIC/WT/SWT/SUV, EXPEDITION TUV, ANGLAIS

FAIT AU / MADE IN CANADA

U/M:P.C.