

ski-doo



OPERATOR'S GUIDE

SAFARI*
L/LE/LX/LXE/LCE/GLX

TOUR

Version française au revers

414 7250 00

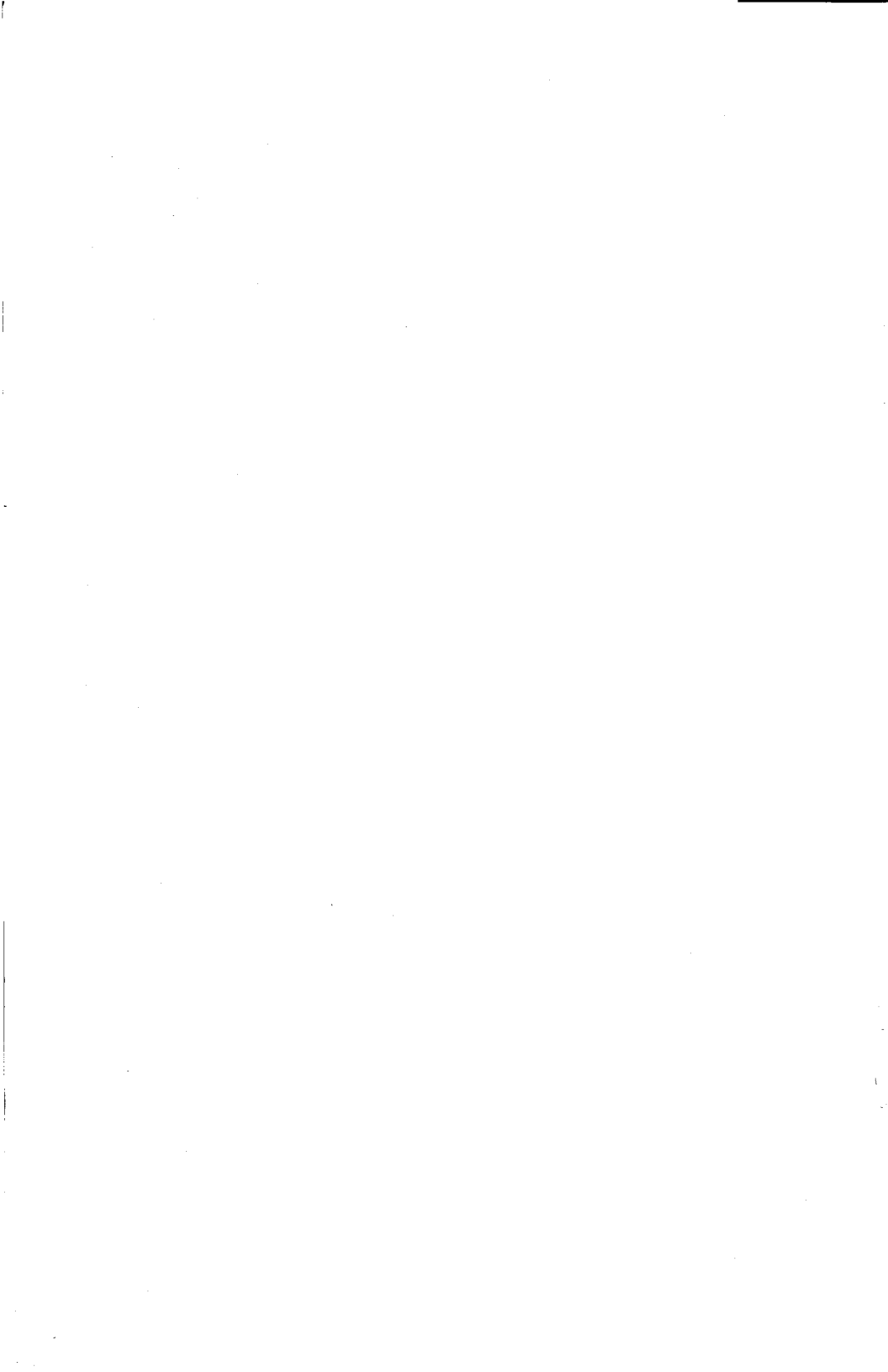

SAFETY WARNING

Disregarding any of the safety precautions and instructions contained in this *Operator's Guide* and the *Safety Handbook* could cause injury, including the possibility of death.

This *Operator's Guide* & the *Safety Handbook* should remain with the vehicle at the time of resale.

AFTER SALES SERVICE
BOMBARDIER INC.
VALCOURT (QUEBEC)
CANADA JOE 2LO



The following are trademarks of Bombardier Inc.

ALPINE®
BOMBARDIER®
CITATION®
ÉLAN®

FORMULA *
NORDIK®
ROTAX®

SAFARI *
SKI-DOO®
TUNDRA *

FOREWORD

The *Operator's Guide* and the *Snowmobiler's Safety Handbook* have been prepared to acquaint the owner/ operator or passenger of a new snowmobile with the various vehicle controls, maintenance and safe operating instructions. Each is indispensable for the proper use of the product, and should be kept with the vehicle at all times.

Should you have any questions pertaining to the warranty and its application, please consult the "Often Asked Question" section of this guide, or an authorized dealer.

This guide uses the following symbols.

 **WARNING** : Identifies an instruction which, if not followed, could cause serious personal injuries including possibility of death.

 **CAUTION** : Denotes an instruction which, if not followed, could severely damage vehicle components.

 **NOTE** : Indicates supplementary information needed to fully complete an instruction.

Although the mere reading of such information does not eliminate the hazard, your understanding of the information will promote its correct use.

The information and components/system descriptions contained in this guide are correct at time of publication. Bombardier Inc. however, maintains a policy of continuous improvement of its products without imposing upon itself any obligation to install them on products previously manufactured.

Bombardier Inc. reserves the right at any time to discontinue or change specifications, designs, features, models or equipment without incurring obligation.

The illustrations show the typical construction of the different assemblies and, in all cases, may not reproduce the full detail or exact shape of the parts shown, however, they represent parts which have the same or a similar function.

Most specifications are given in both metric and customary units. Where precise accuracy is not required, some conversions are rounded off for easier use.

A *Shop Manual* can be obtained for complete service, maintenance and repair information.

 **WARNING** : The engines and the corresponding components identified in this guide should not be utilized on product(s) other than those mentioned on the cover page of this guide.

 **WARNING** : Maintenance procedures and tightening torques must be strictly adhered to, never attempt repairs unless the appropriate tools are available.

 **CAUTION** : Most components of this vehicle are built with parts dimensioned in the metric system. Most fasteners are metric and must not be replaced by customary fasteners or vice versa. Mismatched or incorrect fasteners could cause damage to the vehicle or possible personal injury.

TABLE OF CONTENTS _____

SAFETY MEASURES	5
THE 1991 SNOWMOBILE LIMITED WARRANTY	6
OFTEN ASKED QUESTIONS	8
LISTING OF AREA DISTRIBUTORS	10
HOW TO IDENTIFY YOUR SNOWMOBILE	12
CONTROLS/INSTRUMENTS	13
Throttle Lever	14
Brake Lever	14
Gear Shift Lever	14
Ignition Switch	14
Headlamp Dimmer Switch	15
Emergency Cut-Out Switch	15
Tether Cut-Out Switch	16
Rewind Starter Handle	16
Primer Button	16
Adjustable Steering Handle	16
Speedometer/Odometer	16
Trip Meter Reset Button	16
Tachometer	16
Electric Fuel Level Gauge	16
Fuel Level Indicator	17
Temperature Gauge	17
High Beam Pilot Lamp	17
Injection Oil Level Pilot Lamp	17
Heated Grip Switch	17
Fuel Tank Cap	17
Hood Latches	17
Tool Kit	18
Tachometer Fuse	18
Starting System Fuse	18
Front Grab Handles	19
Storage Compartment	19
BREAK-IN PERIOD	20
Engine	20
Belt	20
10-Hour Inspection	20
10-Hour Inspection Checklist	21
FUEL & OIL	22
Recommended Fuel	22
Recommended Oil	22
Oil Injection System	22
PRE-START CHECK	23
Check Points	23
STARTING PROCEDURE	24
Manual Starting	24
Before Riding	24
Emergency Starting	24

LUBRICATION		26	
Frequency	26	Brake Caliper	28
Steering Mechanism	26	Chaincase/Transmission Oil Level	28
Slide Suspension	27	Oil Injection System	28
MAINTENANCE		29	
Service and Maintenance Chart ..	29	Skis and Runners	42
Drive Belt Removal and Installation	30	Steering Adjustment	42
Drive Belt Condition	32	Exhaust System	42
New Drive Belt	32	Engine Compartment	43
Brake Condition	32	Air Filter	43
Brake Adjustment	32	Carburetor Adjustment	43
Drive Chain Tension	33	High Altitude Kit	44
Spark Plugs	33	Oil Injection System	44
Battery	34	Cooling System	45
Suspension Condition	34	Fan Belt	45
Suspension Adjustment	35	Headlamp Beam Aiming	45
Track Condition	40	Bulb Replacement	46
Track Tension and Alignment ...	40	Wiring Harnesses, Cables and Lines	46
Drive and Driven Pulleys	42	General Inspection	46
Steering Mechanism and Front Suspension	42		
STORAGE		47	
Track	47	Drive and Driven Pulleys	48
Controls	47	Fuel Tank and Carburetor(s)	48
Battery	47	General Inspection	49
Engine	48		
PRE-SEASON PREPARATION		50	
Pre-Season Preparation Chart		50	
TROUBLESHOOTING		51	
TOOLS		54	
SPECIFICATIONS		55	
SI* METRIC INFORMATION GUIDE		61	

SAFETY MEASURES

Observe the Following Precautions :

- Throttle mechanism should be checked for free movement before starting engine.
- Do not operate vehicle near snow making equipment.
- The snowmobile engine can be stopped by activating the emergency cut-out or tether switches or turning off the key.
- Clean and check operation of the headlight, tail light and brake light.
- Engine should be running only when belt guard and/or pulley guard is secured in place.
- Never run the engine without drive belt installed. Running an unloaded engine can prove to be dangerous.
- Never run the engine when the track is raised off the ground.
- It can be dangerous to run engine with the hood removed.
- Gasoline is flammable and explosive under certain conditions. Always manipulate in a well ventilated area. Do not smoke or allow open flames or sparks in the vicinity. If gasoline fumes are noticed while driving, the cause should be determined and corrected without delay.
- Maintain your vehicle in top mechanical condition at all times.
- Your snowmobile is not designed to be driven or operated on black top, bare earth, ice, hard pack or other abrasive surfaces. On such surfaces abnormal and excessive wear of critical parts is inevitable.
- Your snowmobile is not designed to be operated on public streets, road or highways. In most States and Provinces, it is considered an illegal operation.
- Installation of other than standard equipment, including ski-spreaders, bumpers, pack racks, etc., could severely affect the stability and safety of your vehicle. Avoid adding on accessories that alter the basic vehicle configuration.
- Whenever the vehicle is parked outdoors, overnight or for a long period, it is suggested to protect it against the inclemency of the weather with a snowmobile cover.
- Do not lubricate throttle and/or brake cables and housings.
- Only perform procedures as detailed in this guide. Unless otherwise specified, engine should be turned OFF for all lubrication and maintenance procedures.
- **Liquid cooled models only :** Since engine cooling is fully in effect only when the vehicle is in motion and driven on snow, it is not recommended that you allow the engine to idle for more than brief periods and/or you drive the vehicle on icy surfaces. Prolonged idling and/or continuous driving on ice may cause engine damage.
- **Liquid cooled models only :** When removing coolant tank cap, first place a cloth over cap then turn cap to its first step to release pressure. Never drain or refill the cooling system when engine is hot.
- Some models are designed for the driver only. No provisions have been made for a passenger.
- Should removal of a locking device be required when undergoing repairs/disassembly, always replace by new ones. Tighten fasteners as specified in the applicable *Shop Manual*.

THE 1991 SNOWMOBILE LIMITED WARRANTY _____

1 - PERIOD

BOMBARDIER INC. as manufacturer, warrants FROM THE DATE OF DELIVERY TO THE FIRST CONSUMER, every 1991 BOMBARDIER® snowmobile, sold as NEW AND UNUSED, and predelivered by an authorized BOMBARDIER® dealer for a period of :

- 12 consecutive months.
- Warranty coverage on all new snowmobiles delivered between August 1st and December 1st of a year will expire on December 1st of the following year.

2 - WHAT BOMBARDIER INC. WILL DO

BOMBARDIER INC. will repair and/or replace, at its option, components defective in material and/or workmanship (under normal use and service), with a genuine BOMBARDIER® component without charge for parts or labour, at any authorized BOMBARDIER® dealer during said warranty period.

3 - CONDITION TO HAVE WARRANTY WORK PERFORMED

Present to the servicing dealer, the hard copy of the BOMBARDIER® Warranty Registration card or proof of purchase received by the customer from the selling dealer at time of delivery.

4 - EXCLUSIONS - ARE NOT WARRANTED

- Normal wear on all items such as, but not limited to :
 - drive belts
 - bulbs
 - slider shoes
 - runners on skis
 - spark plugs
- Replacement parts and/or accessories which are not genuine BOMBARDIER® parts and/or accessories.
- Damage resulting from installation of parts other than genuine BOMBARDIER® parts.
- Damage caused by failure to provide proper maintenance as detailed in the *Operator's Guide*. The labour, parts and lubricants costs of all maintenance services, including tune-ups and adjustments will be charged to the owner.
- Cold seizure and piston scuffing caused by insufficient warm-up.
- Vehicles designed and/or used for racing purposes.
- All optional accessories installed on the vehicle. (The normal warranty policy for parts and accessories, if any, applies).
- Damage resulting from accident, fire or other casualty, misuse, abuse or neglect.
- Damage resulting from operation of the snowmobile on surfaces other than snow.
- Damage resulting from modification to the snowmobile not approved in writing by BOMBARDIER INC.
- Damage incurred by track studs.
- Losses incurred by the snowmobile owner other than parts and labour, such as, but not limited to, transportation, towing, telephone calls, taxis, or any other incidental or consequential damage.

5 - BATTERY WARRANTY :

- 12 consecutive months (Pro-rated).

100% warranty coverage will start on the date the snowmobile was delivered and run to the following April 30th. The remainder of the 12 month-period will be pro-rated as follows :

- 50% from April 30th to December 1st.
- 40% from December 1st to December 31st.
- 30% from January 1st to end of warranty.

6 - EXPRESSED OR IMPLIED WARRANTIES

This warranty gives you specific rights and you may also have other legal rights which may vary from state to state, or province to province. Where applicable this warranty is expressly in lieu of all other expressed or implied warranties of BOMBARDIER INC., its distributors and the selling dealer, including any warranty of merchantability or fitness for any particular purpose ; otherwise the implied warranty is limited to the duration of this warranty. However, some states or provinces do not allow limitations on how long an implied warranty lasts, so the above limitation may not apply.

Neither the distributor, the selling dealer, nor any other person has been authorized to make any affirmation, representation or warranty other than those contained in this warranty, and if made, such affirmation, representation or warranty shall not be enforceable against BOMBARDIER INC. or any other person.

Some states or provinces do not allow the exclusion or limitation of incidental or consequential damages, so the above limitation or exclusion may not apply.

BOMBARDIER INC. reserves the right to modify its warranty policy at any time, being understood that such modification will not alter the warranty conditions applicable to vehicles sold while the above warranty is in effect.

7 - CONSUMER ASSISTANCE

If a servicing problem or other difficulty occurs we suggest that you try to solve it with your selling dealer. Discuss your concern with the Service Manager or Owner. In most cases you will have your concern resolved at this level.

If you still have a service or product complaint, you may contact the Customer Service Department in Valcourt. Write or call to :

Bombardier Inc.
Customer Service Department
Snowmobile Division
Valcourt, Quebec
Canada JOE 2L0
Phone no : (514) 532-2211

December 1989
Bombardier Inc.
Valcourt, Quebec, Canada JOE 2L0

®*Trademarks of Bombardier Inc.

OFTEN ASKED QUESTIONS

Q : Why must my snowmobile be registered at the factory? After all I do have my original invoice as proof of when I purchased my snowmobile.

A : Registration is very important and your dealer must register your snowmobile with Bombardier Inc. Make sure the card has been sent. All of this will allow you to :

a) have warranty work performed at any authorized Bombardier dealer in North America. Your registration card will provide the dealer with all the necessary data to complete warranty claim forms.

b) be advised by Bombardier should there be a safety recall or particular warranty campaign.

c) be contacted much faster by the police, the minute they find your stolen vehicle (if such a case occurs).

Q : Why must my snowmobile be registered with the governing body having jurisdiction over snowmobile use?

A : Snowmobile registration has two purposes : In many provinces or states it is mandatory to register a snowmobile in the same way as for a car. It allows the state or province to maintain records of existing snowmobiles and governmental agencies use part of the registration fees for establishing and maintaining trails.

Q : Where can I find information on the lubrication and maintenance of my snowmobile?

A : In this Operator's Guide provided with the vehicle at the time of delivery.

Q : Will the entire warranty be void or cancelled, if I do not operate or maintain my new snowmobile exactly as specified in the *Operator's Guide*?

A : The warranty of the new snowmobile cannot be "Voided" or "Cancelled" if pre-delivered by an authorized dealer. However, if a particular failure is caused by operation or maintenance other than is shown in the Operator's Guide, THAT failure may not be covered under warranty. This includes service work performed by the customer, especially the critical adjustments to ignition, timing, carburation and oil injection/or oil mixture.

Q : Would you give some examples of abnormal use or strain, neglect or abuse which may affect warranty?

A : These terms are general and overlap each other in areas. Some specific examples may include : running the machine out of oil, chain failure caused by a lack of lubrication, operating the machine with a broken or damaged part which causes another part to fail, and so on. If you have any specific questions on operation or maintenance, please contact your dealer for advice.

Q : What costs are my responsibility during the warranty period?

A : The customer's responsibility includes all costs of normal maintenance services, non-warranty repairs, accidents and collision damage, as well as oils, and spark plugs, and incidental or consequential damages costs as explained in the warranty.

Q : Are "Genuine" Bombardier replacement parts used in warranty repairs covered by warranty?

A : Yes. When installed by an authorized dealer, any "Genuine" Bombardier part used in warranty repairs assumes the remaining warranty that exists on the machine.

Q : If I sell my snowmobile within the warranty period, will the new owner qualify for the balance of the warranty?

A : Yes, provided the unit has been registered with the manufacturer.

Q : How can I receive the best owner assistance?

A : The satisfaction and goodwill of the owners of Bombardier products are of primary concern to any dealers and Bombardier Inc. Normally, any problems that arise in connection with the sales transaction or the operation of your snowmobile will be handled by your Dealers Sales or Service Departments. It is recognized, however, that despite the best intentions of everyone concerned, misunderstandings will sometimes occur. Frequently, complaints are the result of a breakdown in communications and can quickly be resolved by a member of the dealership management. If the problem already has been reviewed with the Sales Manager or Service Manager, contact the Dealer himself or the General Manager.

LISTING OF AREA DISTRIBUTORS



CANADIAN DISTRIBUTORS

PROVINCE OF QUEBEC

SERVICE OFFICE

BOMBARDIER INC.
Valcourt (Quebec) JOE 2L0
(514) 532-2211

SALES OFFICE

BOMBARDIER INC.
1350 Nobel street
Boucherville (Quebec) J4B 1A1
(514) 655-6121

PROVINCE OF ONTARIO

SERVICE OFFICE

BOMBARDIER INC.
230 Bayview Drive
Barrie (Ontario) L4N 5E9
(705) 728-8600

SALES OFFICE

BOMBARDIER INC.
230 Bayview Drive
Barrie (Ontario) L4N 5E9
(705) 728-8600

MARITIMES

SERVICE OFFICE

BOMBARDIER INC.
P.O. Box 7060
Riverview (New Brunswick) E1B 1V0
(506) 386-6117

SALES OFFICE

BOMBARDIER INC.
1350 Nobel Street
Boucherville (Quebec) J4B 1A1
(514) 655-6121

ALBERTA, BRITISH COLUMBIA, MANITOBA, SASKATCHEWAN, YUKON

SERVICE OFFICE

BROOKS EQUIPMENT LIMITED
1616 King Edward Street
P.O. Box 985
Winnipeg (Manitoba) R3C 2V8
(204) 633-7247

SALES OFFICE

BROOKS EQUIPMENT LIMITED
1616 King Edward Street
P.O. Box 985
Winnipeg (Manitoba) R3C 2V8
(204) 633-7247

NEWFOUNDLAND, LABRADOR

SERVICE OFFICE

CHARLES R. BELL LIMITED
Riverside Drive P.O. Box 1050
Corner Brook (Newfoundland) A2H 6J3
(709) 634-3533

SALES OFFICE

CHARLES R. BELL LIMITED
Riverside Drive P.O. Box 1050
Corner Brook (Newfoundland) A2H 6J3
(709) 634-3533

NORTH-WEST TERRITORIES, FRANKLIN DISTRICT & KEEWATIN

SERVICE OFFICE

NORTHERN STORES INC.
165 Hymus Blvd
Pointe-Claire (Quebec) H9R 1G2
(514) 630-5279

SALES OFFICE

NORTHERN STORES INC.
165 Hymus Blvd
Pointe-Claire (Quebec) H9R 1G2
(514) 630 5279



AMERICAN DISTRIBUTORS

EAST-CENTRAL, CENTRAL REGIONS

SERVICE OFFICE

BOMBARDIER CORPORATION
4418 Grand Avenue
Duluth, Minnesota 55807 U.S.A.
(218) 628-2881

SALES OFFICE

BOMBARDIER CORPORATION
7575 Bombardier Court
P.O. Box 8035
Wausau, Wisconsin 54402-8035 U.S.A.
(715) 842-8886

OR

BOMBARDIER CORPORATION
7575 Bombardier Court
P.O. Box 8035
Wausau, Wisconsin
54402-8035
U.S.A.
(715) 842-8886

WESTERN REGION

SERVICE OFFICE

BOMBARDIER CORPORATION
P.O. Box 1572
Golden, Colorado 80402-1572 U.S.A.
(303) 232-5284

SALES OFFICE

BOMBARDIER CORPORATION
7575 Bombardier Court
P.O. Box 8035
Wausau Wisconsin 55402-8035 U.S.A.
(715) 842-8886

EASTERN REGION

SERVICE OFFICE

BOMBARDIER CORPORATION
East Main Street Road
Malone, New-York 12953 U.S.A.
(518) 483-4411

SALES OFFICE

BOMBARDIER CORPORATION
East Main Street Road
Malone, New-York 12953 U.S.A.
(518) 483-4411

OR

BOMBARDIER INC.
P.O. Box 7060
Riverview (New Brunswick) E1B 1V0
CANADA
(506) 386-6117

ALASKA

SERVICE OFFICE

THE BRYANT CORPORATION
NE. 190th & Woodinville
Snohomish Road
P.O. Box 389
Woodinville, Wa 98072 U.S.A.
(206) 483-0110

SALES OFFICE

BRYANT CORPORATION
NE. 190th & Woodinville
Snohomish Road
P.O. Box 389
Woodinville, Wa 98072 U.S.A.
(206) 483-0110

HOW TO IDENTIFY YOUR SNOWMOBILE

The main components of your snowmobile (engine, track and frame) are identified by different serial numbers. It may sometimes become necessary to locate these numbers for warranty purposes or to trace your snowmobile in the event of loss.

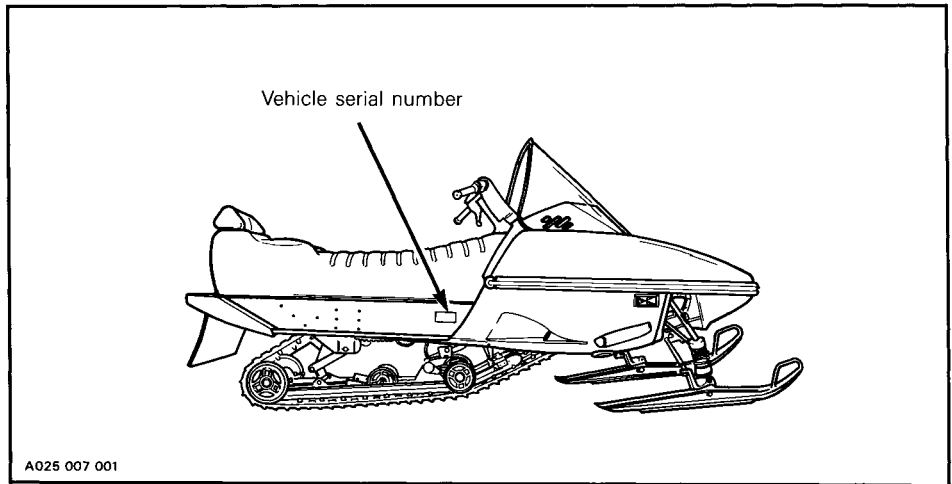
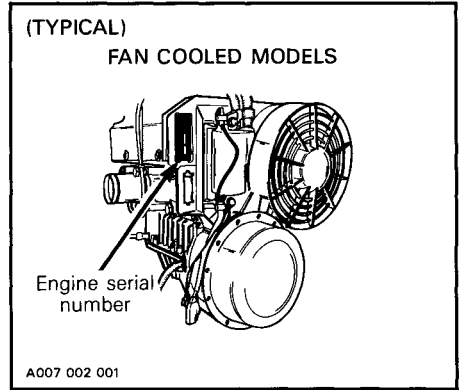
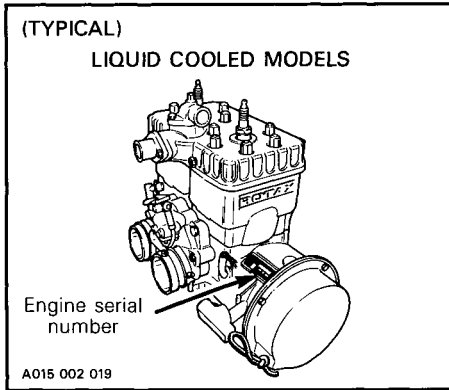

○ **NOTE :** We strongly recommend that you take note of all the serial numbers on your vehicle and supply them to your insurance company.

CONTROLS/ INSTRUMENTS

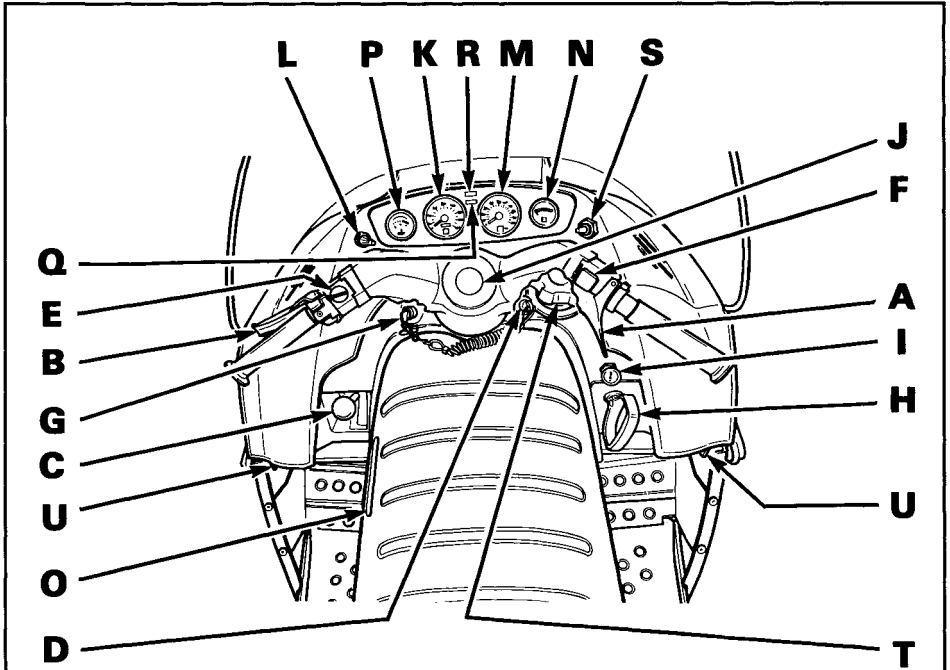

A025 007 002

- | | |
|---|--|
| A) Throttle lever | M) Tachometer (some models only) |
| B) Brake lever | N) Electric fuel level gauge (some models only) |
| C) Gear shift lever (models with reverse gear only) | O) Fuel level indicator (some models only) |
| D) Ignition switch | P) Temperature gauge (liquid cooled models only) |
| E) Headlamp dimmer switch | Q) High beam pilot lamp |
| F) Emergency cut-out switch | R) Injection oil level pilot lamp |
| G) Tether cut-out switch | S) Heated grip switch (some models only) |
| H) Rewind starter handle | T) Fuel tank cap |
| I) Primer button | U) Hood latches |
| J) Adjustable steering handle | |
| K) Speedometer/odometer | |
| L) Trip meter reset button (some models only) | |

A) Throttle Lever

Located on the right side of handlebar. When compressed, it controls the engine speed and the engagement of the transmission. When released, engine speed returns automatically to idle.

B) Brake Lever

Located on the left side of handlebar. When compressed, the brake is applied. When released, it automatically returns to its original position. Braking effect is proportional to the pressure applied on the lever and to the type of terrain and its snow coverage.

C) Gear Shift Lever (models with reverse gear only)

A three-position lever.

Center position : Park. Should be used when vehicle is parked or stored.

Up position : Forward gear.

Down position : Reverse gear.

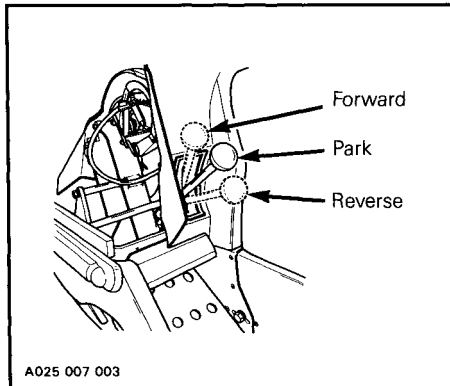

Shifting Procedure

When shifting from FORWARD to REVERSE gear or conversely, the transmission may lock in PARK position.

From the PARK position, release shifter lever and activate throttle lever sufficiently so that drive belt rotates (engine slightly above 3300 RPM) which in turn, synchronizes transmission gears.

▼ **CAUTION** : Since transmission is in park position, do not overrev engine as this will cause premature wear of drive belt.

— Move shifter lever in desired position.

◆ **WARNING** : This snowmobile is capable of a fast reverse. On first outing, operator should become familiar with this operation by practicing on level ground. Always apply the brake before shifting and come to a complete stop then while holding brake on, change gear. This is particularly important while on a slope. Ensure the path behind is clear of obstacles or bystanders. Fast reverse, while turning, could result in loss of stability.

D) Ignition Switch

The lights are automatically ON whenever the engine is running.

Manual Starting (some models only)

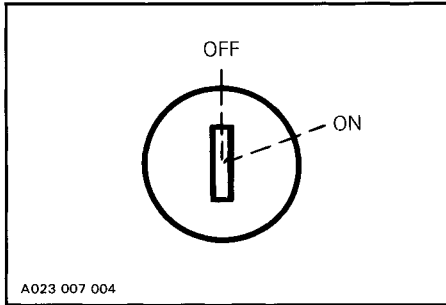

Key operated, two-position switch. To start the engine, first turn the key to ON position. To stop the engine, turn the key to OFF position.

Electric Starting (some models only)

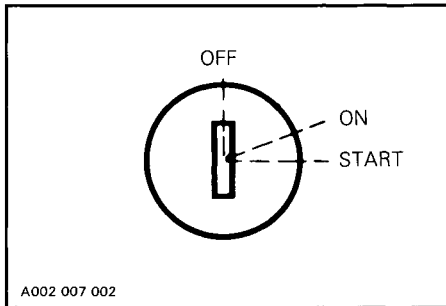

Key, operated, three-position switch. To start engine, turn key to START position and hold. Release key to ON position immediately when engine has started. If engine does not start on first try, key must be turned fully back to OFF each time. To stop engine, turn key to OFF position.

CAUTION : Holding key in START position when engine has started could damage starter mechanism.

E) Headlamp Dimmer Switch

The dimmer switch, located on left side of handlebar, allows correct selection of headlamp beam. To obtain high or low beam simply flick switch.

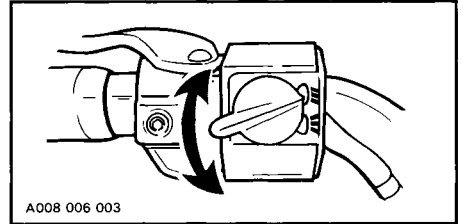

F) Emergency Cut-Out Switch

To stop the engine in an emergency, push the button to the lower off position and simultaneously apply the brakes. To start engine, button must be at the upper on position.

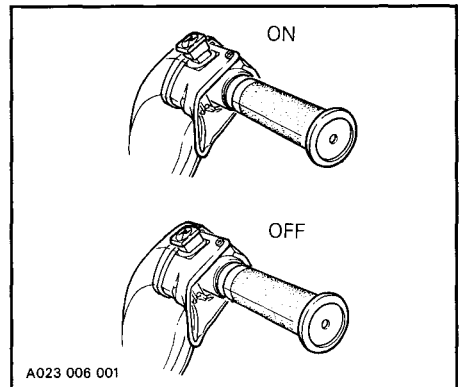

WARNING : If the switch has been used in an emergency situation the source of malfunction should be determined and corrected before restarting engine.

G) Tether Cut-out Switch

A pull switch located on left side of console. Attach tether cord to wrist or other convenient location then snap tether cut-out cap over receptacle before starting engine.

If emergency engine "shut off" is required, completely pull cap from safety switch and engine power will be automatically "shut off".

○ **NOTE** : The cap must be installed on the safety switch at all times in order to operate the vehicle.

◆ **WARNING** : If the switch is used in an emergency situation the source of malfunction should be determined and corrected before restarting engine.

H) Rewind Starter Handle

Auto rewind type located on right hand side of vehicle. To engage mechanism, pull handle slowly until a resistance is felt then pull vigorously.

I) Primer Button

Pull and push button (two three times) to start a cold engine.

J) Adjustable Steering Handle

Steering handle height is adjustable, see an authorized dealer.

K) Speedometer/Odometer

The speedometer is linked directly to the drive axle. Direct-reading dial indicates the speed of the vehicle in kilometers per hour. Odometer records the total distance travelled in kilometers.

Trip Meter (some models only)

Speedometer features a trip meter that records a distance travelled in kilometers until it is reset. It can be used to record a fuel tank range or distance between two relays for instance.

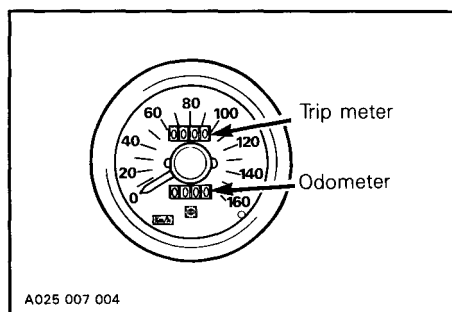

L) Trip Meter Reset Button (some models only)

Trip meter reset button is located in dashboard. To reset, turn button until all numbers read zero.

M) Tachometer (some models only)

The tachometer registers the impulses of magneto. Direct-reading dial indicates the number of revolutions per minute (RPM) of the engine.

N) Electric Fuel Level Gauge (some models only)

The electric fuel gauge is located in the dashboard and allows driver to observe the fuel while riding the snowmobile.

O) Fuel Level Indicator (some models only)

Mounted on left side of fuel tank, it provides visual indication of fuel level in tank.

P) Temperature Gauge (liquid cooled models only)

The gauge indicates engine coolant temperature. Normal operating temperature is from 50° to 100° (120° - 212°F).

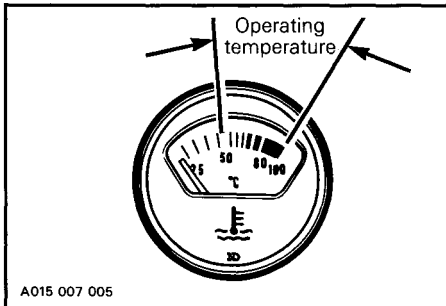

However, coolant temperature can vary according to driving conditions. If coolant temperature exceeds 100°C (212°F) reduce speed and run vehicle in loose snow or stop engine immediately.

◆ **WARNING:** To remove coolant tank cap, place a cloth over the cap and unscrew it to the first stop to release the pressure. If this notice is disregarded loss of fluid and severe burns could occur.

Q) High Beam Pilot Lamp (Blue)

Lights when headlamp is on high beam.

R) Injection Oil Level Pilot Lamp (Red)

Lights when injection oil level is low. Check level and replenish as soon as possible.

▼ **CAUTION:** Do not run engine out of oil. Serious engine damage will occur.

○ **NOTE:** Whenever brake lever is actuated, oil injection level pilot lamp should light up. If not replace lamp.

S) Heated Grip Switch

The three-position toggle switch is located on right side of dashboard. Select the desired position to keep hands at a comfortable temperature.

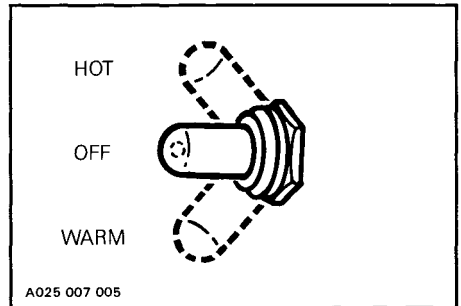

T) Fuel Tank Cap

Unscrew to fill up tank then fully tighten.

◆ **WARNING:** Never use an open flame to check fuel level.

U) Hood Latches

Pull down the latches to unlock the hood from its anchors.

○ NOTE : Always lift hood gently until stopped by retaining device.

◆ WARNING : It is dangerous to run an engine with the hood opened, unfastened or removed.

Tool Kit

To gain access, open hood.

Tachometer Fuse (some models only)

The tachometer is protected by a 0.1 ampere rated fuse. Fuse holder is located inside the hood near the tachometer. If it stops operating, check fuse condition and replace if necessary.

▼ CAUTION : Do not use a higher rated fuse as this can cause severe damage to the tachometer.

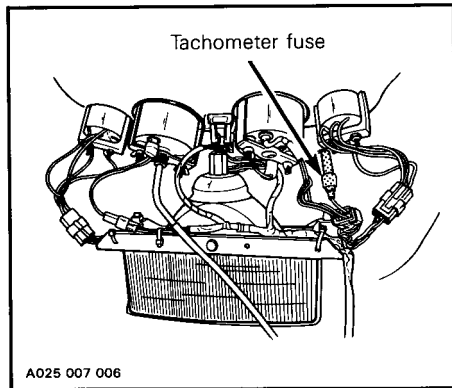

Starting System Fuse

Starting system is protected with a 30 amperes rated fuse. See following illustrations for fuse holder location. If starter does not operate, check fuse condition and if necessary replace.

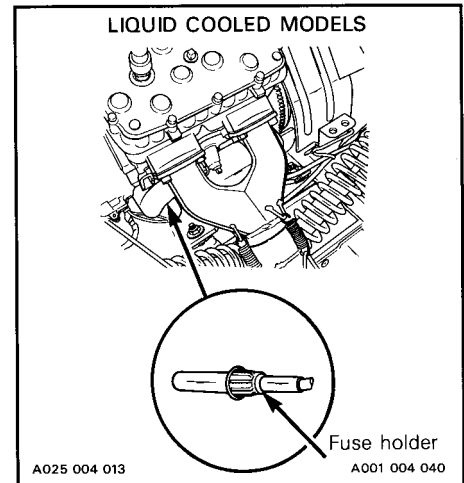
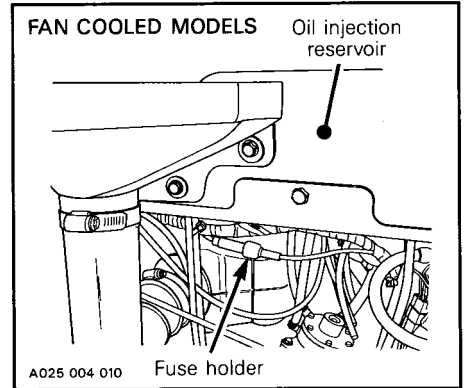

Front Grab Handles

Located at the front of the bottom pan, these grab handles must be used whenever front of vehicle is lifted.

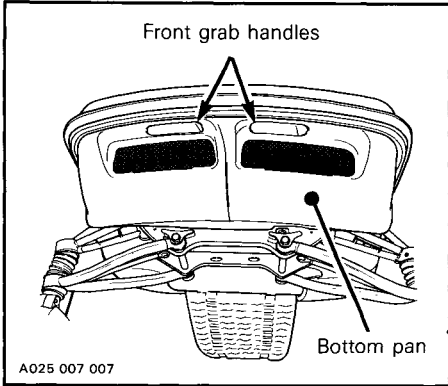

▼ **CAUTION** : Do not use skis to pull or lift vehicle.

Storage Compartment (some models only)

Push button to open cover.

◆ **WARNING** : Do not sit on cover at rear of seat while riding.

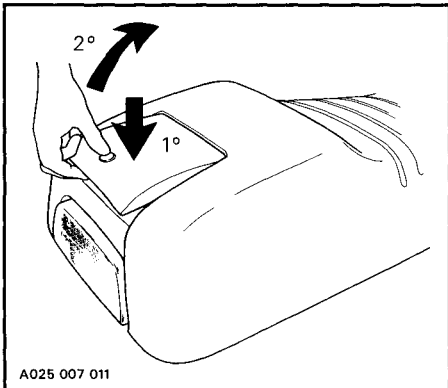

BREAK-IN PERIOD

Engine

With Bombardier-Rotax snowmobile engines, a break-in period is required before running the vehicle at full throttle. Engine manufacturer's recommendation is 10 to 15 operating hours. During this period, maximum throttle should not exceed 3/4, however, brief full acceleration and speed variations contribute to a good break-in. Continued wide open throttle accelerations, prolonged cruising speeds, and engine overheating are detrimental during the break-in period.

○ **NOTE** : To assure additional protection during the initial engine break-in, 500 mL (17 oz) of BLIZZARD OIL (P/N 496 0135 00) or the same quantity of BOMBARDIER Injection Oil (P/N 496 0133 00) should be added to fuel for the first full fuel tank filling.

▼ **CAUTION** : Remove and clean spark plugs after engine break-in.

Belt

A new drive belt requires a break-in period of 25 km (15 miles).

10-Hour Inspection

As with any precision piece of mechanical equipment, we suggest that after the first 10 hours of operation or 30 days after the purchase, whichever comes first, your vehicle be checked by your authorized dealer. This inspection will give you the opportunity to discuss the unanswered questions you may have encountered during the first hours of operation.

The 10-hour inspection is at the expense of the vehicle owner.

10 - HOUR INSPECTION CHECKLIST	✓
Engine timing	
Fan belt tension	
Spark plug condition (remove and clean)	
Carburetor adjustments	
Oil injection pump adjustment	
Engine head nuts	
Drive pulley screw (torque)	
Engine mount screws	
Muffler attachment	
Chaincase/transmission oil level	
Drive chain tension	
Injection system oil level	
Coolant level	
Brake operation and lining condition	
Ski alignment (runners condition)	
Handlebar bolts (torque)	
Driven pulley preload	
Pulley alignment and drive belt condition	
Track condition, tension and alignment	
Suspension, torque rear axle screw to 48 N•m (35 lbf•ft)	
Lubrication (steering, suspension, drive axle, etc.)	
Electrical wiring, routing/connections	
Tighten all loose bolts, nuts and linkage	
Operation of lighting system (HI / LO beam, brake light, etc.), test operation of emergency cut-out switch and tether cut-out switch	
Battery electrolyte level (electric start only)	

We recommend that you have your dealer sign this inspection.

Date of 10-hour inspection

Dealer signature

FUEL & OIL

Recommended Fuel

Use regular unleaded gasoline, available from most service stations or gasohol containing less than 10% of ethanol.

◆ **WARNING** : Remove fuel tank cap slowly. Fuel may be under pressure and spray may cause fire and injuries. Fuel is flammable and explosive under certain conditions. Always manipulate in a well ventilated area. Do not smoke or allow open flames or sparks in the vicinity.

▼ **CAUTION** : Never experiment with other fuels or fuel ratios. The use of fuel containing methanol, or similar products including naphtha is not recommended. The use of unrec-ommended fuel can result in vehicle performance deterioration and damage to critical parts in the fuel system and engine components.

◆ **WARNING** : Never top up the fuel tank before placing the vehicle in a warm area. At certain temperatures, fuel will expand and overflow. Always wipe off any fuel spillage from the snowmobile.

Recommended Oil

Use BOMBARDIER Snowmobile Injection Oil (P/N 496 0133 00 - 1 liter) available from the authorized dealer. This type of oil will flow at temperatures as low as minus 40°C (-40°F).

If BOMBARDIER Snowmobile Injection Oil is unavailable, substitute with BLIZZARD Oil (P/N 496 0135 00).

▼ **CAUTION** : Never mix brands of two-cycle oil as chemical reaction can cause severe damage. Never use outboard or straight mineral oils.

Oil Injection System

Always maintain a sufficient amount of BOMBARDIER Snowmobile Injection Oil in the injection oil reservoir.

▼ **CAUTION** : Never allow oil level to drop more than 2/3.

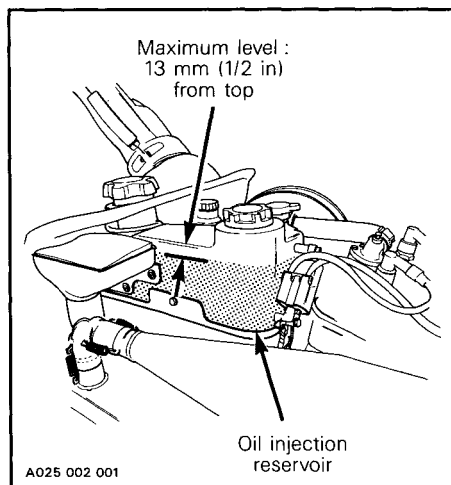

▼ **CAUTION** : Check level and refill every time you refuel. Do not overfill. Wipe off any spillage.

○ **NOTE** : For initial engine break-in, fill up fuel tank and add 500 mL (17 oz) of BLIZZARD or same quantity of BOMBARDIER Injection Oil.

PRE-START CHECK

Check Points

- ACTIVATE THE THROTTLE CONTROL LEVER SEVERAL TIMES to check that it operates easily and smoothly. It must return to idle position when released.
- Check that the skis and the track are not frozen to the ground or snow surface and that steering operates freely.
- Check that air filter is free of snow.
- Activate the brake control lever and make sure the brake fully applies before the brake control lever touches the handlebar grip.
- Check coolant level. Liquid should be at cold level mark (engine cold).

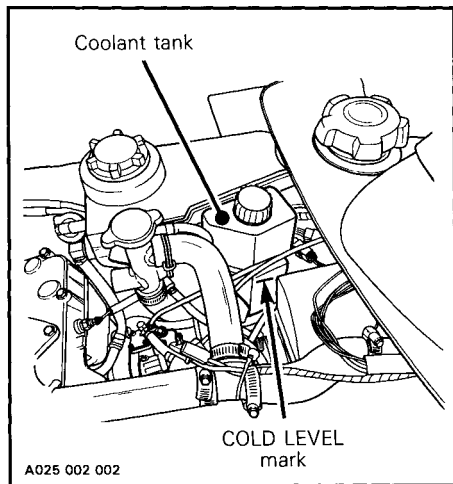

If additional coolant is necessary or if entire system has to be refilled, use a solution of three parts of antifreeze for two parts of water (60% antifreeze, 40% water).

○ **NOTE** : Always use ethylene-glycol antifreeze containing corrosion inhibitors specifically recommended for aluminum engines.

◆ **WARNING** : Before removing the radiator pressure cap place a cloth over the cap and unscrew it to the first step to release the pressure. Never drain or refill the cooling system when engine is hot. Loss of fluid and severe burns could occur if this notice is disregarded.

- Check injection oil level.
- Check fuel level.
- Ensure gear shift lever is in PARK position (models with reverse gear only).
- Verify that the path ahead of the vehicle is clear of bystanders and obstacles.
- Clean and check operation of the headlight, taillight and brake light.

◆ **WARNING** : Only start your snowmobile once all components are checked and functioning properly.

STARTING PROCEDURE

Test throttle control lever operation.
Check that the emergency cut-out switch is in the ON position.

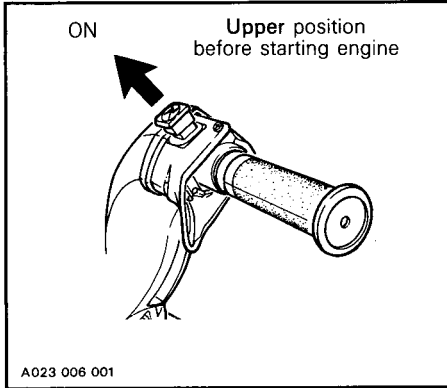

Ensure the tether cut-out cap is in position and that the cord is attached to your clothing.

Activate the primer button two or three times.

○ **NOTE** : Primer is not necessary when the engine is warm.

▼ **CAUTION** : Use of ether and/or other types of fluid as a starting aid can cause damage to engine components and is not recommended.

Manual Starting

Insert the key in the ignition and turn to ON position.

Grasp manual starter handle firmly and pull slowly until a resistance is felt then pull vigorously. Slowly release the rewind starter handle.

◆ **WARNING** : Do not apply throttle while starting.

Before Riding

Check operation of the emergency cut-out switch and tether switch. Restart engine.

◆ **WARNING** : If engine does not shut-off when applying the emergency cut-out switch and/or when pulling the tether cut-out cap, stop the engine by turning OFF the ignition key. Do not operate the vehicle further, see an authorized dealer.

Allow the engine to warm before operating at full throttle.

○ **NOTE** : Liquid cooled models only : Engine is warm when operating temperature has been reached on temperature gauge. On fans cooled models without temperature gauge, let engine idle three to five minutes.

◆ **WARNING** : This snowmobile is propelled by a revolving track which must be partially exposed for proper operation. Serious injuries may be caused by operator carelessness, resulting in hands, feet or clothing becoming entangled in the track.

Emergency Starting

Should the rewind starter rope fray and break, the engine can be started with the emergency starter rope supplied with the tool kit.

◆ **WARNING** : Do not wind starting rope around your hand. Hold rope by the handle only.

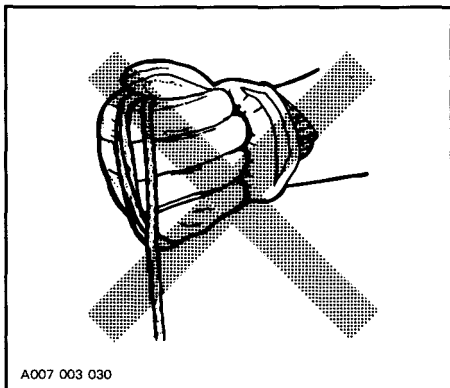

A007 003 030

◆ **WARNING :** Do not start the vehicle by the drive pulley unless it is a true emergency situation. Have the vehicle repaired as soon as possible.

Attach emergency rope to any available handle and to the starter clip supplied in the tool box. Wind the rope tightly around drive pulley so that when pulled, pulley will rotate counterclockwise.

○ **NOTE :** The spark plug socket can be used as an emergency starter grip.

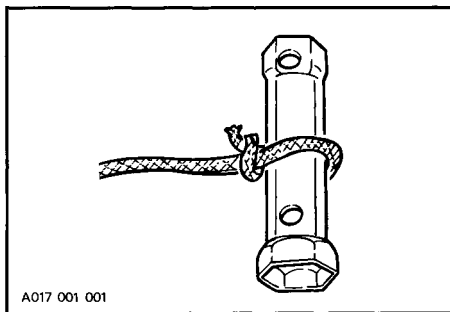

A017 001 001

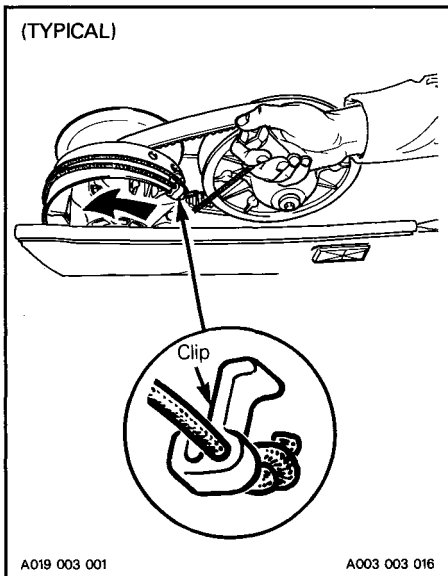

A019 003 001

A003 003 016

Start engine as per usual manual starting.

◆ **WARNING :** When starting the vehicle in an emergency situation, using drive pulley, do not reinstall the belt guard and return slowly to have vehicle repaired.

LUBRICATION

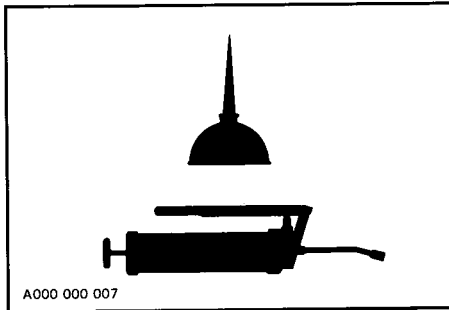

Frequency

Routine maintenance is necessary for all mechanized products, and the snowmobile is no exception. A weekly vehicle inspection contributes to the life span of the snowmobile.

It is recommended that the steering system and suspension be lubricated monthly or every 40 hours of operation. If the vehicle is operated in wet snow or in severe conditions these items should be lubricated more frequently.

○ **NOTE:** When lubricating grease fittings, slowly pump grease gun until grease appears at joints. Always use low temperature grease (P/N 413 7061 00).

◆ **WARNING:** Only perform such procedures as detailed in this guide. It is recommended that dealer assistance be periodically obtained on other components/systems not covered in this guide. Unless otherwise specified, engine should be turned OFF for all lubrication and maintenance procedures. Do not lubricate throttle and/or brake cables and housings.

Steering Mechanism

○ **NOTE:** Take this opportunity to verify tightness of fasteners and ball joints. From underneath of bottom pan, lubricate both rocker arms of steering system.

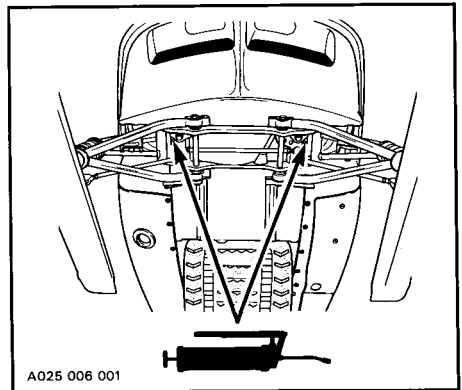

Oil upper and lower steering column bushings.

Inspect ski leg boots for damage such as tears or cracks. If damaged, refer to an authorized dealer.

Once a year, ski leg ball joints and ski pivot should be lubricated.

— Remove boot locking rings

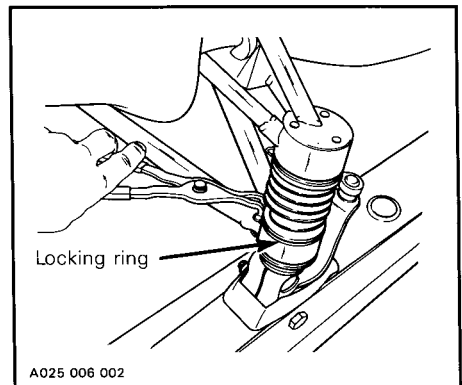

- Slide boot to access ball joints.
- Apply small amount of grease on all ball joints.

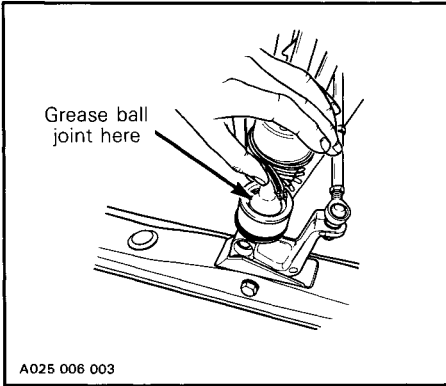

- Properly secure boot.
- Remove ski and apply grease on ski pivot.
- Proceed the same way on the other side.

Slide Suspension

Lubricate the following parts at grease fitting until grease appears at joints. Use low temperature grease only.

Front upper cross shaft.

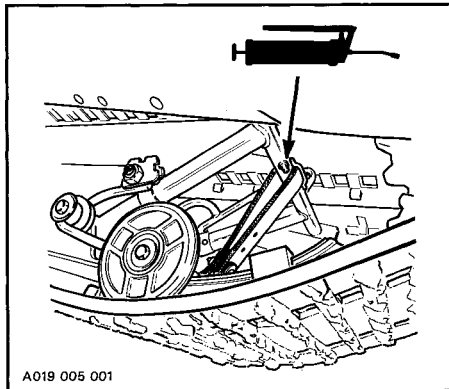

Front lower cross shaft.

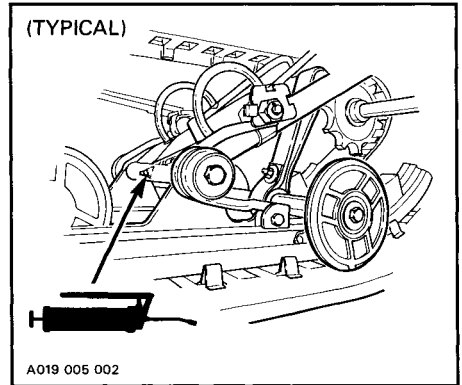

Rear upper cross shaft.

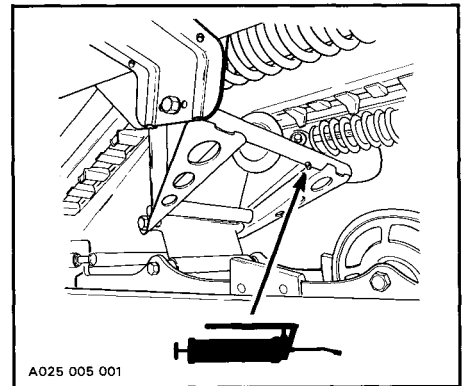

Rear pivot arm shaft.

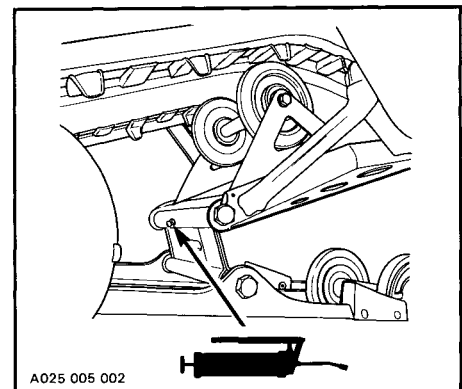

Brake Caliper

See your authorized dealer for proper lubrication of brake caliper ratchet wheel.

◆ **WARNING:** Do not lubricate throttle and/or brake cables and housings.

Chaincase/Transmission Oil Level

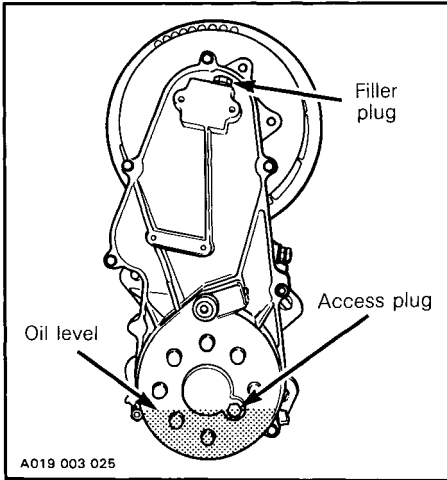

To fill, remove filler plug from top of transmission. Refill as required using Bombardier chaincase oil (P/N 413 8019 00 - 250 mL).

○ **NOTE:** The chaincase oil capacity is approximately 250 mL (9 imp. oz) on models without reverse gear and 500 mL (18 imp. oz) on transmission with reverse gear.

Oil Injection System

Always maintain a sufficient amount of Bombardier Snowmobile Injection Oil in the injection oil reservoir.

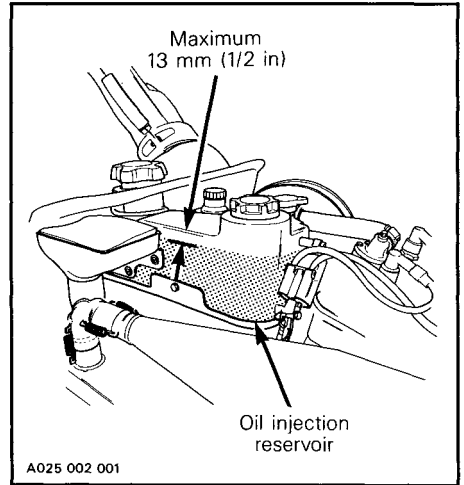

▼ **CAUTION:** Check level and refill every time you refuel. Do not overfill. Wipe off any spillage.

MAINTENANCE

The following Maintenance Chart indicates regular servicing scheduled to be performed by you or your authorized dealer. If these services are performed as suggested, your snowmobile will provide many years of use.

 **NOTE** : Shadow areas in chart indicate recommended frequency.

 **WARNING** : Only perform such procedures as detailed in this guide. It is recommended that dealer assistance be periodically obtained on other components/systems not covered in this guide. Unless otherwise specified, engine should be turned OFF for all lubrication and maintenance procedures.

SERVICE AND MAINTENANCE CHART	Weekly or every 240 km (150 mi)	Monthly or every 800 km (500 mi)	Once a year or every 3200 km (2000 mi)	Refer to page
Drive belt condition				32
Brake condition				32
Brake adjustment				32
Drive chain tension				33
Spark plugs				33
Battery (Electric starting only)				34
Suspension condition				34
Suspension adjustment		(as required)		35
Track condition				40
Track tension and alignment		(as required)		40
Drive and driven pulleys				42
Steering mechanism and front suspension				42
Skis and runners				42
Steering adjustment				42
Exhaust system				42
Engine compartment				43
Air filter cleaning				43
Carburetor adjustment (cable inspection)				43
Injection oil filter condition				44
Oil injection pump adjustment				44
Cooling system (liquid cooled models only)				45
Fan belt (fan cooled models only)				45
Headlamp beam aiming				45
Wiring harnesses, cables and lines				46
General inspection				46

 **NOTE** : The 10-hour inspection is a very important part of proper service and maintenance.

Drive Belt Removal and Installation

1. Remove ignition key.
2. Tilt the hood.
3. Pull out both retaining pins on ends of belt guard. On Safari LCE remove tool bag to make room.

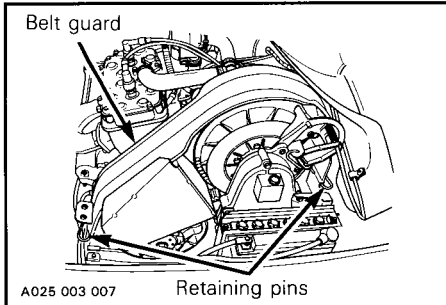

4. Lift and remove the belt guard.

WARNING: Engine should be running only when belt guard is secured in place.

5. Unlock and raise driven pulley support.

Fan Cooled Models Only.

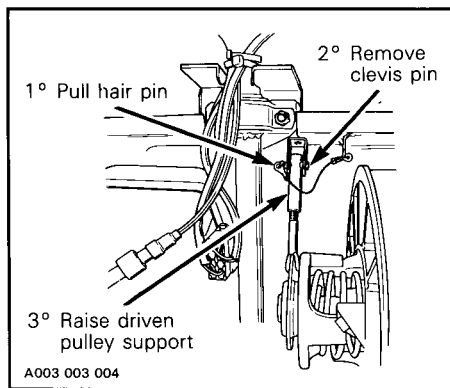

Liquid Cooled Models Only

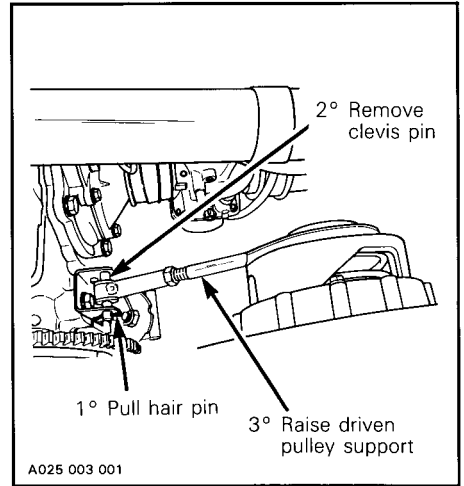

NOTE: Removal and installation of drive belt is easier when driven pulley is held with brake so that it can not rotate. Starter rope, in tool kit, may be tied tightly around brake lever at handlebar for this purpose.

6. Open the driven pulley by twisting and pushing the sliding half. Hold in fully open position.

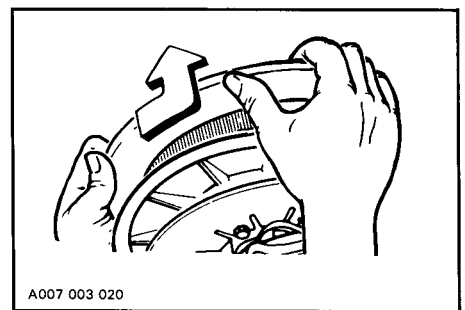

7. Slip slackened belt over the top edge of the sliding half.

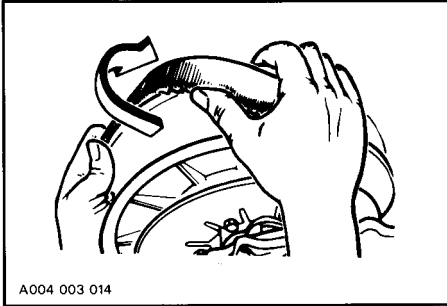

8. Slip the belt out from the drive pulley and remove completely from vehicle.

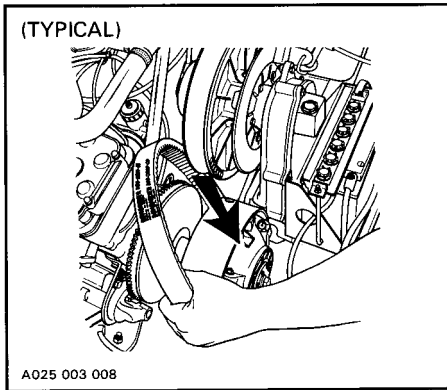

◆ **WARNING** : Never start or run engine without the drive belt installed. Running an unloaded engine is dangerous.

To install the drive belt, reverse the procedure, however pay attention to the following.

The maximum drive belt life span is obtained when the belt has the proper rotation direction. Install it so the Bombardier name can be read when facing pulleys.

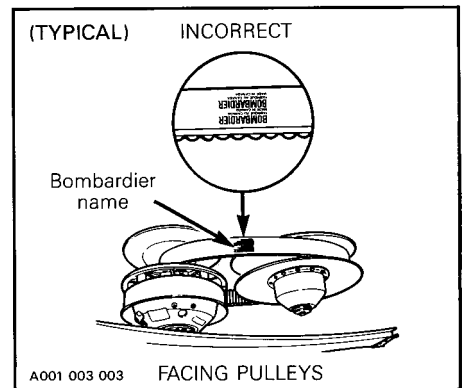
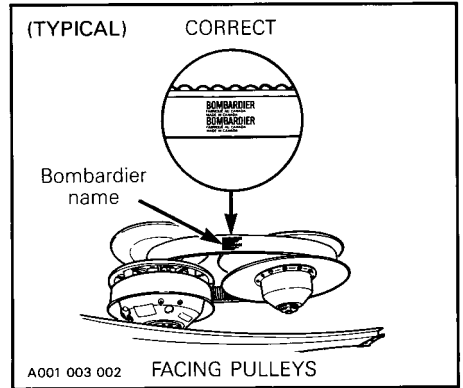

▼ **CAUTION** : Do not force or use tools to pry the belt into place, as this could cut or break the cords in the belt.

Drive Belt Condition

Inspect belt for cracks, fraying or abnormal wear (uneven wear, wear on one side, missing cogs, cracked fabric). If abnormal wear is noted, probable cause could be pulley misalignment, excessive RPM with frozen track, fast starts without warm-up period, burred or rusty sheave, oil on belt or distorted spare belt. Contact an authorized dealer.

Check the drive belt width. If less than 32 mm (1-1/4 in), replace the drive belt.

New Drive Belt

When installing a new drive belt, break-in period of 25 km (15 miles) is strongly recommended.

○ **NOTE** : Always store a spare belt in a manner to allow its natural shape to be maintained.

Brake Condition

The brake mechanism on the snowmobile is an essential safety device. Keep this mechanism in proper working condition. Above all, do not operate the snowmobile without an effective brake system.

◆ **WARNING** : Brake pads must be replaced when fixed pad projects only 1 mm (1/32 in) from caliper. Replacement must be performed by an authorized dealer.

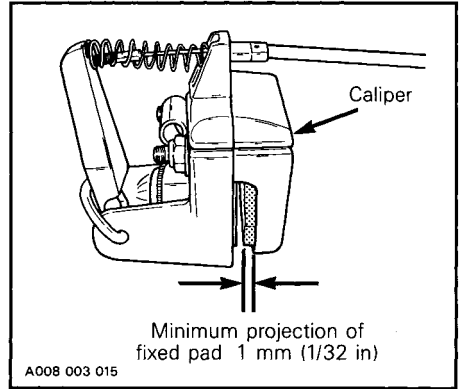

Brake Adjustment

The brake mechanism is a self-adjusting type. If a quicker brake response is desired, strongly squeeze the brake lever several times, this will actuate the self adjusting mechanism.

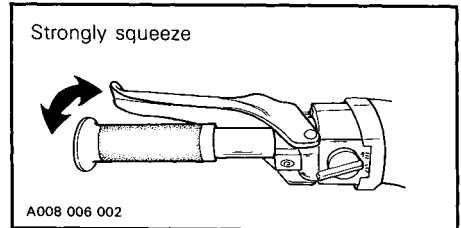

After the adjustment, brake should apply fully when lever is approximately 13 mm (1/2 in) from handlebar grip. If not, do not tamper with the brake, contact an dealer.

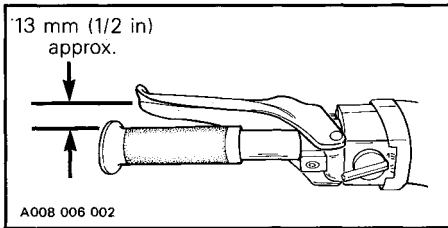

Drive Chain Tension

Run vehicle forward so that true free-play can be taken. To adjust, remove the hair pin from adjusting screw. Fully tighten adjusting screw **by hand** then back off only far enough for hair pin to engage in locking hole.

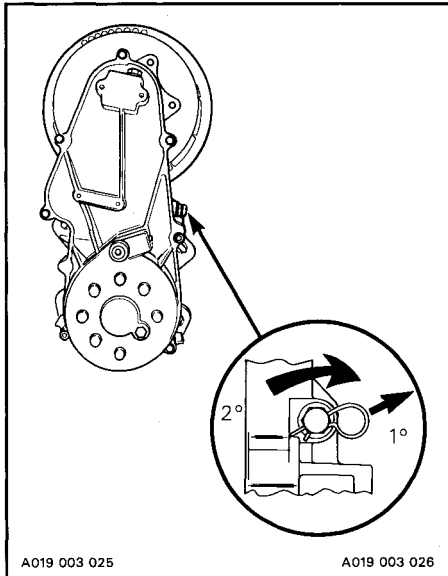

WARNING : If proper adjustment is not reached with the tensioner screw fully tightened, consult an authorized dealer.

Spark Plugs

Disconnect the spark plug wires and remove the spark plugs.

Check the condition of the plugs.

- A brownish tip reflects ideal conditions. (Carburetor adjustments, spark plug heat range, etc., are correct).
- A black insulator tip indicates fouling caused by : carburetor idle speed mixture and/or high speed mixture too rich, incorrect fuel mixture ratio, wrong type of spark plug (heat range), or excessive idling.
- A light grey insulator tip indicates a lean mixture caused by : carburetor high speed mixture adjusted too lean, wrong spark plug heat range, incorrect fuel mixture ratio, or a leaking seal or gasket.

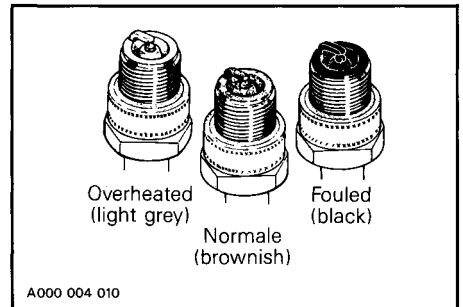

CAUTION : If spark plug condition is not ideal, contact your authorized dealer.

Check spark plug gap using a wire feeler gauge adjust as specified in "specifications" section. Reinstall plugs and connect wires.

Battery (electric starting only)

Check electrolyte level weekly. Electrolyte level must be at upper level line on battery casing.

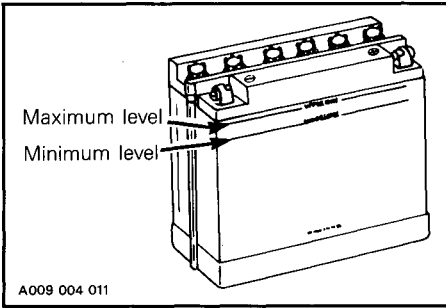

If necessary add distilled water. Battery connections must also be free of corrosion. If cleaning is necessary remove corrosion using a stiff brush then clean with a solution of baking soda and water. Rinse and dry well.

CAUTION: Do not allow cleaning solution to enter battery. It will destroy the chemical properties of the electrolyte.

After reconnecting battery, coat battery terminals and connectors with petroleum jelly to prevent corrosion. Check that battery is well secured and that battery vent tube is not kinked or blocked.

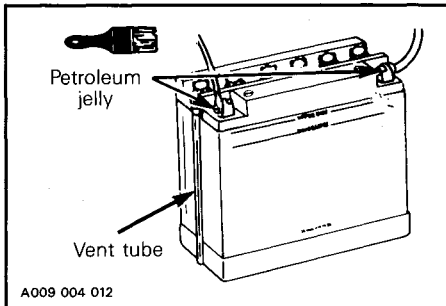

WARNING: Vent tube must be free and open. If not, it will restrict ventilation and create a gas accumulation that could result in an explosion. Avoid skin contact with electrolyte.

CAUTION: Be careful not to ground positive terminal with the chassis. Always disconnect black negative cable first. Prior to charging the battery, always remove it from the vehicle to prevent electrolyte spillage.

NOTE: Always keep battery fully charged. (To charge, refer to "Battery" in "Storage" section).

WARNING: Gases given off by a battery being charged are highly explosive. Always charge in a well ventilated area. Keep battery away from cigarettes or open flames. Avoid skin contact with electrolyte

Suspension Condition

Visually inspect all suspension components.

NOTE: During normal driving, snow will act as a lubricant and coolant for the slider shoes. Extensive riding on ice or sanded snow, will create excessive heat build-up and cause premature slider shoe wear.

Suspension Adjustment

The front and rear suspensions are adjustable. **Front suspension** includes two-shock absorber/spring combination that have a three-position adjustment cam. See an authorized dealer for adjustment.

Front Suspension Adjustment

The preload of shock absorber spring can be adjusted as follows :

SPRING END/ STOPPER DISTANCE	CONDITION
Smallest Closest	Soft riding, smooth trail
Intermediate	Normal riding
Greatest Farthest	hard surface

○ **NOTE :** Exhaust muffler or shock absorber may be removed to ease adjustment cam access. See an authorized dealer.

Rear suspension includes two torsional springs at **front portion** that have a four-position adjustment block, and adjustable stopper strap and finally two shock absorber/spring combination at **rear portion** that have a five-position adjustment cam.

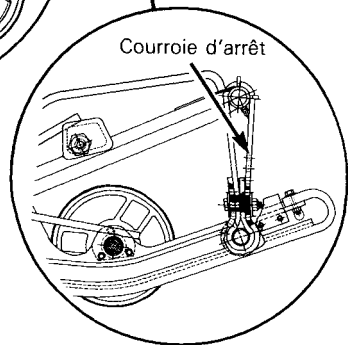
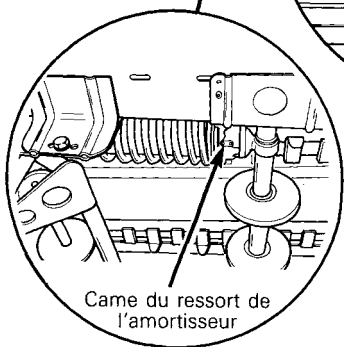
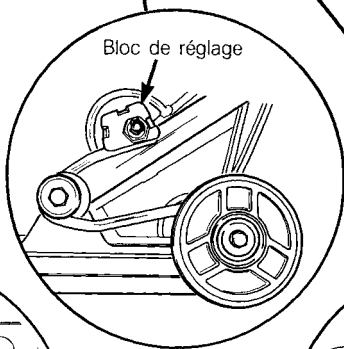
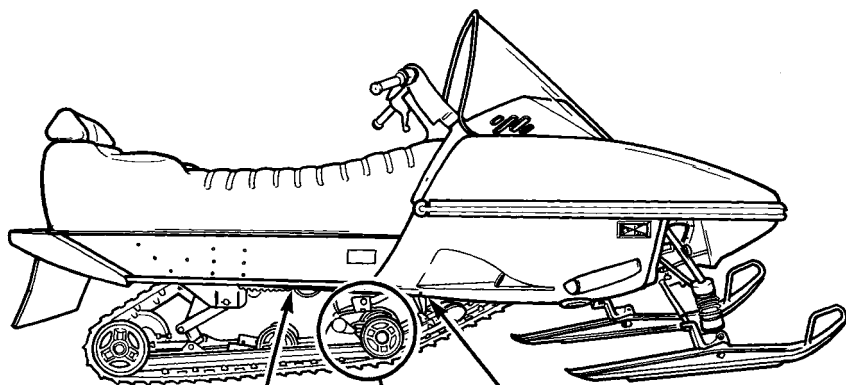

A025 005 005

The front suspension is adjustable for surface condition, vehicle handling and stability.

The front portion of rear suspension is adjustable for surface condition and steering effects.

The stopper strap is adjustable for vehicle weight transfer control.

The rear portion of rear suspension is adjustable for driver's weight.

Choice of suspension adjustments depends on carrying load, driver's weight, personal preference, riding speed and field condition.

Cam/block position	Soft → stiff
Operator's weight	Light → Heavy
Riding speed	Low → High
Field condition	Flat → Bumpy

Slight suspension bottoming occurring under the worst riding conditions indicates a good choice of preload adjustment (cam/block position).

Optional different rate springs are available for your convenience. Ask an authorized dealer for more information.

Suspension is adjusted as outlined in the following lines.

Adjustment Block Tool

To adjust rear suspension adjustment blocks, use the special key supplied in tool kit.

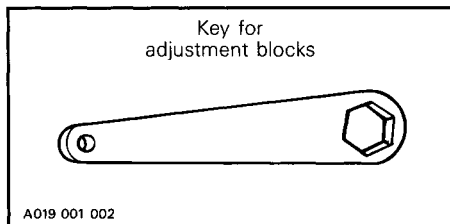

Turning adjustment block moves edges of block supporting spring rod. The softest adjustment is reached when the supporting edge of block is the closest to hexagonal portion of block.

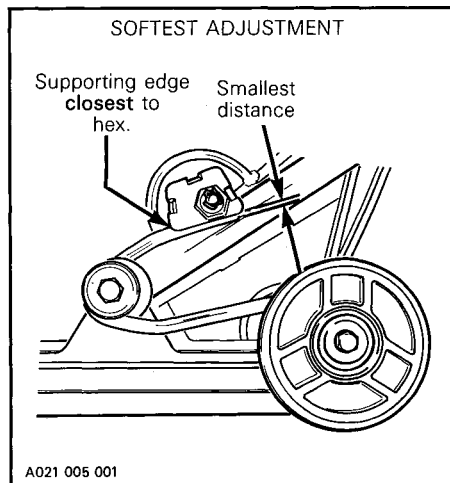

The stiffest adjustment is reached when the supporting edge of block is the farthest to hexagonal portion of block.

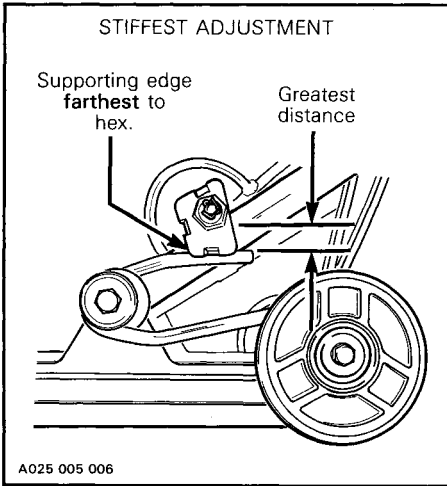

▼ **CAUTION** : Always turn the left side adjuster block in a clockwise direction, the right side block in a counterclockwise direction. Left and right adjuster blocks must always be set at the same position.

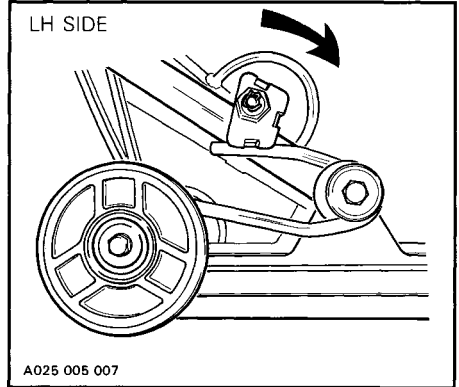
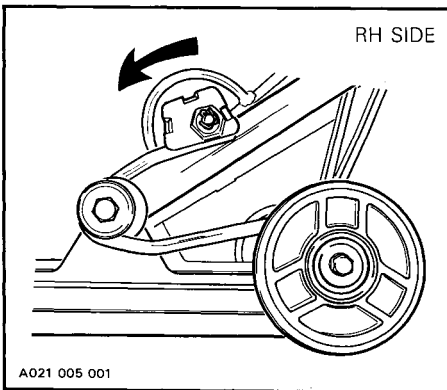

Shock Absorber Spring Cam Tool

To adjust rear suspension shock absorber springs, use the special key supplied in tool kit.

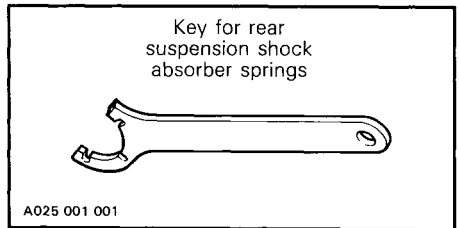

Turning adjustment cam moves steps of cam over a stopper and controls cam height which in turn, change compressed length of spring. Spring preload can be increased or decreased by turning the cam.

The softest adjustment is reached when selected cam step is the closest to spring end.

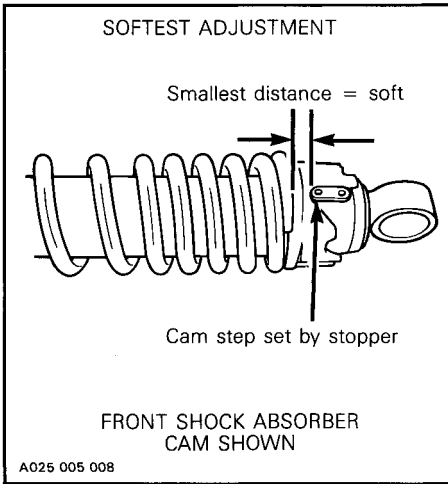

The stiffest adjustment is reached when selected cam step is the farthest to spring end.

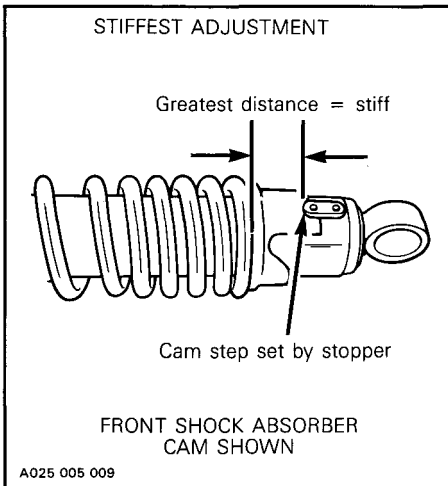

CAUTION: Always adjust left and right shock absorber spring cams at the same position.

Rear Suspension Adjustment

Adjustment Blocks

When the adjustment blocks are set at the softest adjustment, more vehicle weight is distributed to the skis thus giving a more positive steering. Track lead angle will be reduced in this position.

Steering stiffness can be reduced by setting adjustment blocks at their stiffest adjustment.

Shock Absorber Spring Cam

The preload of shock absorber springs can be adjusted as follows :

SPRING END / STOPPER DISTANCE	DRIVER'S WEIGHT kg (lb)	
	FROM	UP TO
Smallest	—	68 (150)
Intermediate	68 (150)	82 (180)
Greatest	82 (180)	—

Stopper Strap

The function of the suspension stopper strap is to control the transfer of vehicle weight during acceleration and to control track lead angle.

The longer the belt, the more the weight will be transferred to the track to provide a better traction. The shorter the belt, the lesser the weight transferred to the track, thus maintaining a more positive direction.

The longer the belt, the greater will be the track lead angle. A shorter belt will reduce track lead angle which may help when negotiating a particular snow condition.

Adjusting holes on the stopper strap allow to adjust it according to driver's requirements, field and/or snow conditions.

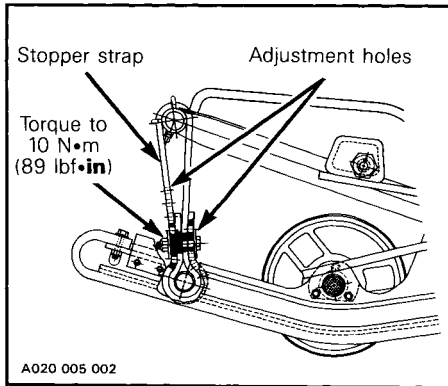

WARNING: Always torque the nut to 10 N•m (89 lbf•in).

Deep Snow Operation

When operating the vehicle in deep snow, it may be necessary to change position of adjustment blocks, shock absorber spring cams, stopper strap and/or driver's riding position, to change the angle at which the track rides on the snow. Operator's familiarity with the various adjustment as well as snow conditions will dictate the most efficient combination.

Track Condition

Lift the rear of the vehicle and support it off the ground. With the engine **OFF**, rotate the track by hand, and inspect condition. If worn or cut, or if track fibers are exposed, or if missing or defective inserts or guides are noted; contact an authorized dealer.

WARNING: Do not operate a snowmobile with a cut, torn or damaged track.

Track Tension and Alignment

Tension

Lift the rear of vehicle and support with a mechanical stand. Allow the slide to extend normally and check the gap half way along slider shoe.

The gap should be 40 mm (1-9/16 in) between the slider shoe and the bottom inside of the track when applying a downward pull of 7.3 kg (16 lb). The gap should be measured close to suspension center idler wheel.

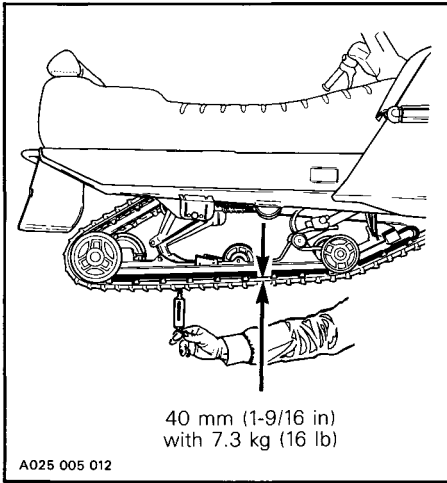

If the track tension is too loose, the track will have a tendency to thump.

CAUTION: Too much tension will result in power loss and excessive stresses on suspension components.

If necessary to adjust; loosen the rear idler wheel retaining screw and the adjuster bolt lock nut; then loosen or tighten the adjuster bolts located on the inner side of the rear idler wheels. If correct tension is unattainable, contact an authorized dealer.

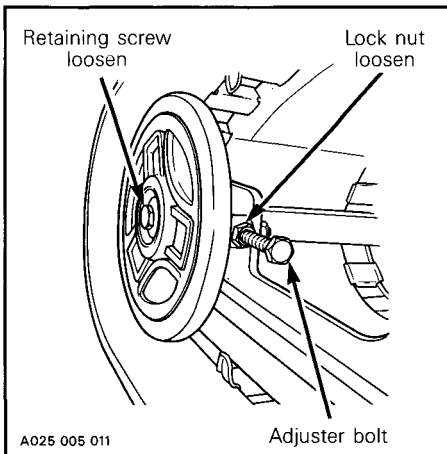

NOTE: Track tension and alignment are inter-related. Do not adjust one without the other.

Alignment

Start the engine and accelerate slightly so that track turns **slowly**. Check that the track is well centered; equal distance on both sides between edges of track guides and slider shoes.

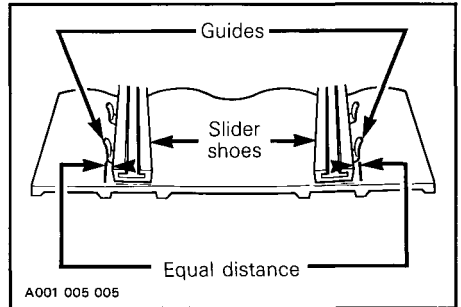

WARNING: Before checking track alignment, ensure that the track is free of all particles which could be thrown out while track is rotating. Keep hands, tools, feet and clothing clear of track. Ensure no one is standing in close proximity to the vehicle.

To correct, **stop the engine**, loosen the rear idler wheels retaining screws then loosen the lock nuts and tighten the adjuster bolt on side where the slider shoe is the farthest from the track insert guides.

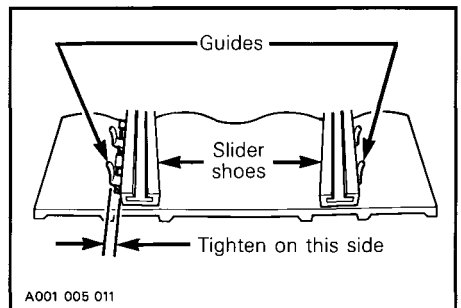

Tighten lock nuts and the idler wheel retaining screws.

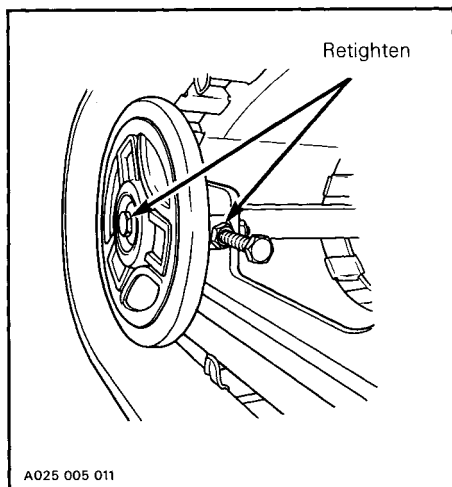

Restart engine, rotate track **slowly** and recheck alignment.

Drive and Driven Pulleys

These are complex mechanism which operate at high rotational speeds. Each pulley is dynamically balanced at the factory. Any tampering by the owner may disrupt this precision balancing and create an unstable condition.

Pulleys are factory adjusted to provide the best performance under most riding conditions. However certain conditions such as deep snow, high altitude, pulling a load, etc., may require different adjustments. Contact the authorized dealer for adjustment.

◆ **WARNING** : The drive and driven pulleys must be inspected and cleaned by an authorized dealer at least annually.

Steering Mechanism and Front Suspension

Inspect the steering mechanism and front suspension.

Skis and Runners

Check the condition of the skis and the ski runners. If worn contact your authorized dealer.

◆ **WARNING** : Excessively worn skis and/or ski runners will hinder proper vehicle control.

Steering Adjustment

Skis should have a toe out of 3 mm (1/8 in).

To check, measure the distance between each ski runner at the front and rear. The front distance should be 3 mm (1/8 in) more than the rear when the handle bar is horizontal.

If adjustment is necessary, refer to an authorized dealer.

Exhaust System

Replace any component which has developed cracks or holes. Ensure muffler is properly secured in its mount and the ends of retaining springs have not been over-stretched. The tail pipe of the muffler should be centered with the exit hole in the bottom pan.

▼ **CAUTION** : Do not operate vehicle with muffler disconnected, serious engine damage will occur.

Engine Compartment

Keep clean of grass, twigs, cloth, etc. These are combustible under certain conditions.

Air Filter

Leaving the vehicle uncovered during a snowfall or riding in deep powder snow may block air filter.

Lift hood and remove air filter from air intake silencer.

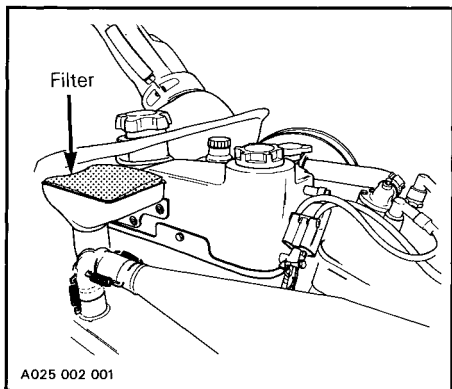

To clean the filter, shake the snow out of it then, dry it out.

Check that the air box is clean and dry and properly reinstall the filter.

▼ **CAUTION** : These vehicles have been calibrated with the filter installed. Operating the vehicle without it will cause damage to the engine.

Carburetor Adjustment

▼ **CAUTION** : Never operate your snowmobile with the air intake silencer disconnected. Serious engine damage will occur if this notice is disregarded.

▼ **CAUTION** : On twin-carburetor models, make sure both carburetors start to operate simultaneously.

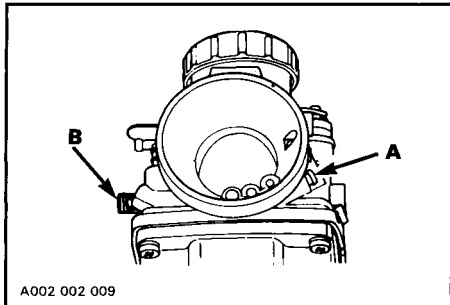

A) Air Screw Adjustment

Slowly close the air screw (until a slight seating resistance is felt) then unscrew as per specified in "specifications" section.

B) Idle Speed Adjustment

Turn idle speed screw clockwise until it contacts the throttle slide then continue turning two additional turns. This will provide a preliminary idle speed setting. Start engine and allow it to warm up. Adjust idle speed to 1800-2000 RPM by turning the idle speed screw clockwise or counterclockwise.

▼ **CAUTION** : Severe engine damage can occur if idle speed is unattainable. Contact your authorized dealer.

High Altitude Kit

Snowmobiles used in high altitude areas (1200 m (4000 ft) and up) are subjected to lose power as temperature, elevation and snow condition are different. The carburetor and power train have to be recalibrated to meet those particular requirements. See an authorized dealer for high altitude kit installation.

▼ **CAUTION** : Do not change original jetting if vehicle is used below 1200 m (4000 ft).

Oil Injection System

Injection Oil Filter Condition

Inspect oil filter at least once a month. Insure that filter is not obstructed by foreign particles ; if so, see an authorized dealer.

LIQUID COOLED MODELS

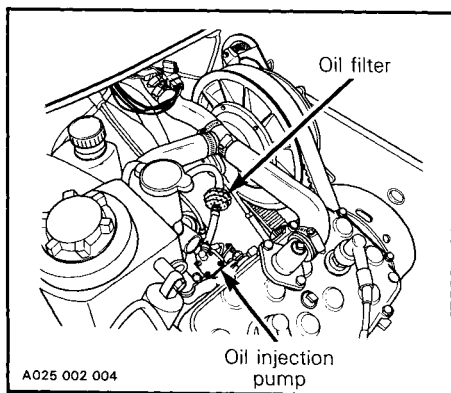

FAN COOLED MODELS

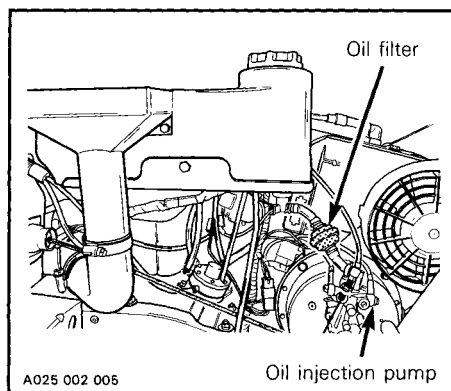

▼ **CAUTION** : An obstructed injection oil filter will cause oil starvation resulting in serious engine damage.

○ **NOTE** : After a storage period, it is important that your dealer replace the injection oil filter, that he verifies the oil flow of the injection pump and adjust it.

Injection Pump Adjustment

Proper oil injection pump adjustment is critical, any delay in the opening of the pump can result in serious engine damage.

▼ **CAUTION** : The carburetor must be adjusted before adjusting the oil injection pump. Make sure idle speed is 1800-2000 RPM.

To check adjustment: eliminate the throttle cable free-play by pressing the throttle lever until a slight resistance is felt then hold in place. The marks on the pump casting and lever must align perfectly. If not, contact an authorized dealer.

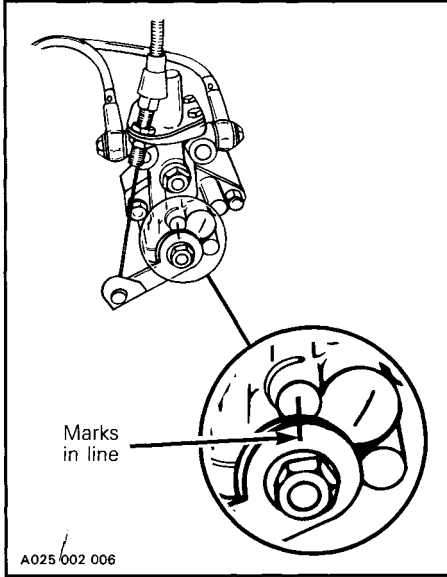

Cooling System (liquid cooled models only)

Check condition of hoses and tightness of clamps.

○ **NOTE:** If coolant temperature rises above recommended range of 50 to 100°C (120 to 212°F), hose off grime from the heat exchanger (underneath the frame above the track). If necessary contact an authorized dealer.

Fan Belt (fan cooled models only)

Inspect belt for cracks, uneven wear, etc. Check fan belt tension, 9.5 mm (3/8 in) deflection should exist.

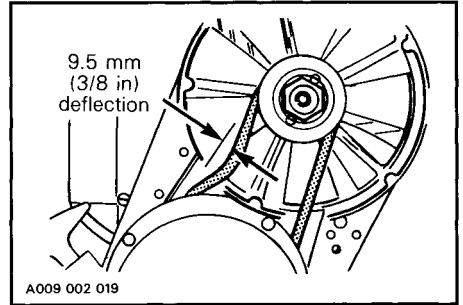

If belt seems damaged or if tension is incorrect, contact an authorized dealer immediately.

Headlamp Beam Aiming

To adjust, remove windshield. Turn adjusting screw to obtain desired beam position. Re-install windshield.

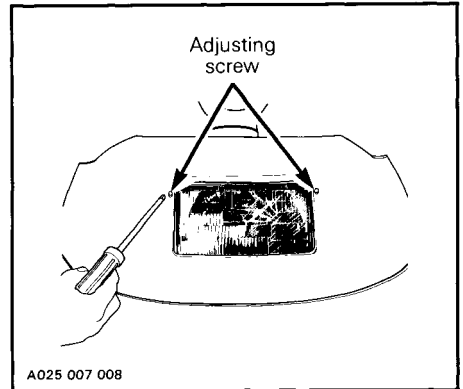

Bulb Replacement

◆ **WARNING** : Always check light operation after bulb replacement.

Headlamp

If the headlamp bulb is burnt, tilt hood, unplug the connector from the headlamp. Remove the rubber boot and unfasten bulb retainer ring. Detach the bulb and replace. Properly re-install.

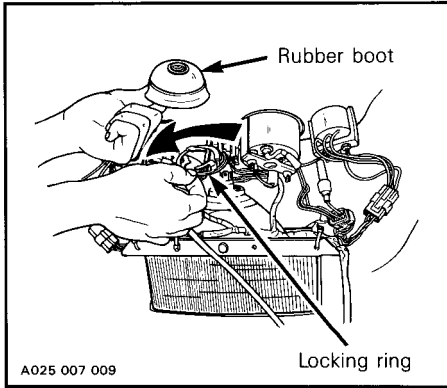

▼ **CAUTION** : On applicable models, never touch glass portion of an halogen bulb with bare fingers, it shortens it's operating life. If by mistake glass is touched clean it with isopropyl alcohol which will not leave a film on the bulb.

Instrument(s)

Bulb socket is always behind the instrument under a black rubber boot. Pull rubber boot and socket to expose bulb. To release bulb, push bulb and at the same time, rotate bulb counterclockwise.

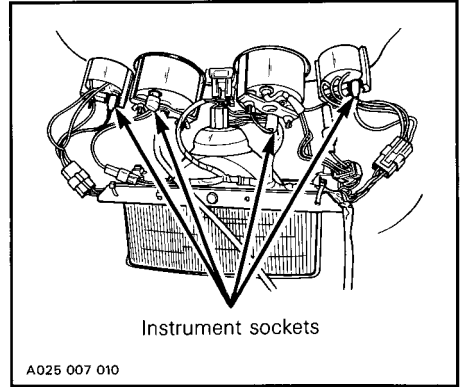

Taillight

If taillight bulb is burnt, expose the bulb by removing the red plastic lens. To remove, unscrew the two screws.

Wiring Harnesses, Cables and Lines

◆ **WARNING** : Ensure each routing is well secured with proper fasten device (locking tie, clip, grommet, etc.) away from hot or rotating components.

General Inspection

Check the electrical wiring and components, retighten loose connections. Check for stripped wires or damaged insulation. Thoroughly inspect the vehicle and tighten loose bolts, nuts and linkage. Inspect skis and ski runners for wear.

STORAGE

It is during summer, or when a vehicle is not in use for any length of time that proper storage is a necessity.

◆ **WARNING** : Only perform such procedures as detailed in this guide. It is recommended that dealer assistance be periodically obtained on other components/systems not covered in this guide. Unless otherwise specified, engine should be turned OFF for all lubrication and maintenance procedures.

Track

Lift rear of vehicle until track is clear of the ground and support with a brace or trestle.

Controls

Lubricate the steering mechanism. Inspect all components for tightness.

◆ **WARNING** : Do not lubricate the throttle and/or brake cables and housings. Avoid getting oil on the brake pads.

Coat all electrical connections and switches with silicone dielectric grease (P/N 413 7017 00). If unavailable, use petroleum jelly.

Battery (electric starting only)

1. Disconnect the battery cables and remove the battery retainer cover.

▼ **CAUTION** : Be careful not to ground positive terminal with the chassis. Always disconnect black negative cable first.

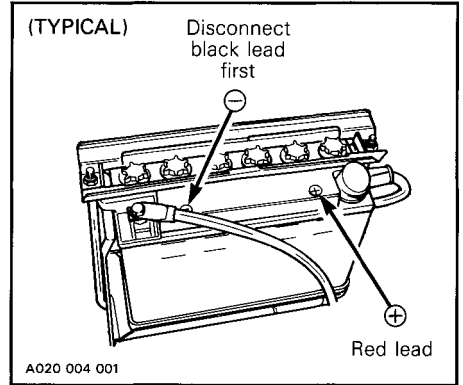

2. Remove the battery vent tube from the vent hole.
3. Lift out the battery.
4. Clean outside surface of battery with solution of baking soda and water. Remove all deposits from posts then rinse with clear tap water.

▼ **CAUTION** : Do not allow cleaning solution to enter battery interior since it will destroy the electrolyte.

5. Check electrolyte level. Refill if necessary with distilled water. Fully charge battery at a maximum rate of 2.0 A.

▼ **CAUTION** : Prior to charging the battery, always remove it from the vehicle to prevent electrolyte spillage.

◆ **WARNING** : Gases given off by a battery being charged are highly explosive. Always charge in a well ventilated area. Keep battery away from cigarettes or open flames. Avoid skin contact with electrolyte.

6. Coat electrical connections and switches with a greaseless metal protector, if unavailable, use petroleum jelly.
7. Store unit in a cool, dry place.

NOTE: To prevent battery from discharging, store it on a wooden shelf away from moisture. A stored battery must be recharged at least every 40 days.

Engine

Engine internal parts must be lubricated to protect them from possible rust formation during the storage period.

To perform the storage procedures proceed as follows :

1. Lift the rear of the vehicle and support it off the ground.

WARNING: Ensure the track is free of all particles which could be thrown out while it is rotating. Keep hands, tools, feet and clothing clear of track. Ensure no one is standing in close proximity to the vehicle.

2. Start the engine and allow it to run at idle speed until the engine reaches its operating temperature.

3. Stop the engine.

4. To prevent fuel from draining, primer button should be pushed all the way.

5. Disconnect the outlet primer hose from the primer valve.

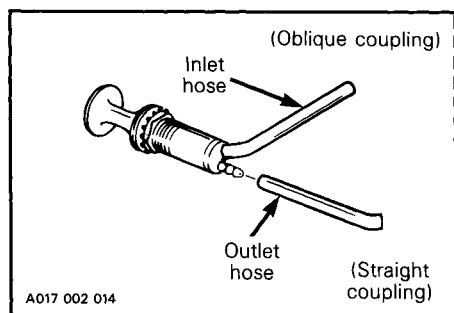

6. Insert storage oil (P/N 496 0141 00) nozzle into primer outlet hose.
7. Restart engine and run at idle speed.
8. Inject storage oil until the engine stalls or until a sufficient quantity of oil has entered the engine (approximately half a can).
9. With the engine stopped, remove the spark plug and spray storage oil (P/N 496 0141 00) into each cylinder.
10. Crank slowly two or three revolutions to lubricate cylinders.
11. Reinstall the spark plugs and the outlet primer hose.

WARNING: This procedure must only be performed in a well ventilated area. Do not run engine during storage period.

Drive and Driven Pulleys

Remove belt guard and slip off drive belt.

Spray metal protector on pulleys.

Fuel Tank and Carburetor(s)

Remove the cap and using a siphon, drain fuel tank.

WARNING: Fuel is flammable and explosive under certain conditions. Always manipulate in a well ventilated area. Do not smoke or allow open flames or sparks in the vicinity.

Carburetor(s) must be dried out completely to prevent gum formation during the storage period.

CAUTION: Due to gum/varnish formation, severe damage can happen.

Once the fuel tank is emptied, remove the float chamber drain plug from carburetor(s) then drain carburetor(s).

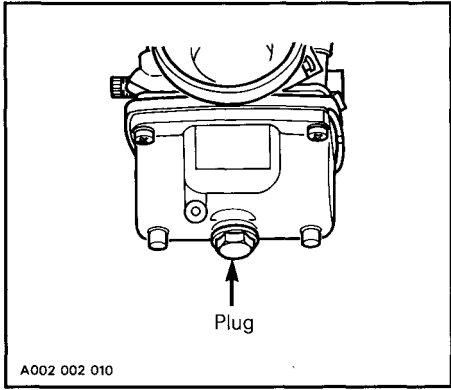

Reinstall plug.

General Inspection

Remove any dirt or rust. Grease at all recommended grease points. Wipe off surplus.

Block air intake hole and exhaust system hole using clean cloths.

▼ **CAUTION :** Plastic alloy components such as fuel tank, windshield, controls, etc., can be cleaned using mild detergents or isopropyl alcohol and a soft clean cloth. Never clean plastic parts with strong detergent, degreasing agent, paint thinner, acetone, etc. Never clean RIM Metton hood with cleaners or products containing chlorine. Do not apply isopropyl alcohol directly on decals.

Inspect the hood and repair any damage. Clean the frame. For the unpainted aluminum portion use only "Aluminum cleaner" and follow instructions on the container.

Touch up all metal spots where paint has been scratched off. Spray all metal parts with metal protector. Wax the hood and the painted portion of the frame for better protection.

○ **NOTE :** Apply wax on glossy finish only. Protect the vehicle with a cover to prevent dust accumulation during storage.

▼ **CAUTION :** The snowmobile has to be stored in a cool and dry place and covered with an opaque tarpaulin. This will prevent sun rays and grime from affecting plastic components and vehicle finish.

PRE-SEASON PREPARATION

To simplify pre-season preparation we have drawn up a small chart. The chart indicates servicing points to be performed by you and your dealer.

IMPORTANT : Observe all Warnings and Cautions mentioned throughout this guide which are pertinent to the item being checked. When component conditions seem less than satisfactory, replace with genuine Bombardier parts or suitable equivalents.

PRE-SEASON PREPARATION CHART	To be performed by dealer ●	Refer to page
	To be performed by owner ○	
Change spark plugs*	○	33
Drain chaincase/transmission oil	○	28
Check drive chain tension	○	33
Refill chaincase/transmission	○	28
Replace fuel and oil filter	●	—
Clean air filter	○	43
Remove cloths from air intake and exhaust system holes	○	49
Refill fuel tank	○	22
Check track condition, tension and alignment	○	40
Check suspension stopper strap condition	○	40
Check and lubricate suspension	○	27
Check pulleys, verify components and clean	●	—
Inspect drive belt guard and install	○	30
Check throttle cable for free operation	○	24
Check steering adjustment and ski runner condition	○	42
Check electrical wiring and connections	○	46
Inspect condition of starting rope	○	16
Check tightness of all bolts, nuts and links	○	—
Change coolant (liquid models only)	●	—
Inspect seals for possible cuts or leaks	○	—
Test battery, clean and install (electric starting models only)	●	—
Inspect brake condition, operation and lubricate ratchet wheel	●	—
Refill injection oil tank	○	22
Adjust oil injection pump	●	—
Set engine timing	●	—
Adjust carburetor(s)	●	—

○ ***NOTE :** Before installing new spark plugs, it is suggested to burn excess storage oil by starting the engine with the old spark plugs.

▼ **CAUTION :** Only perform this operation in a well ventilated area.

INCIDENTS DE FONCTIONNEMENT

CONSTATATIONS	CAUSES PROBABLES	SOLUTIONS
Le moteur tourne mais ne démarre pas	1. L'interrupteur d'allumage, l'interrupteur d'urgence ou le capuchon coupe-circuit est à la position ARRÊT	Placer tous les interrupteurs en position MARCHE.
	2. Le mélange n'est pas assez riche pour faire démarrer le moteur lorsqu'il est à froid	Vérifier le niveau du réservoir de carburant ainsi que la section de démarrage, afin de comprendre en quoi consiste l'amorceur.
	3. Moteur noyé. (Lorsque la bougie est enlevée, elle est humide)	Ne pas trop amorcer. Enlever la bougie humide et amener le commutateur d'allumage à la position ARRÊT. Faire tourner le moteur manuellement. Installer une bougie neuve. Faire démarrer le moteur de la façon habituelle. Si l'ennui persiste, voir votre concessionnaire autorisé.
	4. Le carburant ne parvient pas au moteur (lorsque la bougie est enlevée, elle est sèche)	Vérifier le niveau du réservoir de carburant, s'il y a lieu, ouvrir la soupape de coupure de carburant ; vérifier le filtre à carburant et le remplacer s'il est obstrué ; vérifier la qualité du carburant, les conduites d'impulsion ainsi que leurs raccords. Il y a eu un bris au niveau de la pompe à carburant ou du carburateur. Consulter votre concessionnaire autorisé.
	5. Bougie/allumage défectueux (aucune étincelle)	Vérifier si l'interrupteur d'urgence est à la position supérieure (MARCHE) et si le capuchon coupe-circuit est refermé sur son réceptacle. Voir si la bougie est encrassée ou défectueuse. Débrancher la bougie et la sortir. Brancher de nouveau le fil à la bougie et mettre celle-ci à la masse sur le moteur en prenant soin de la tenir éloignée de l'orifice . Mettre le moteur en marche et voir s'il y a des étincelles. Sinon, remplacer la bougie. Si l'ennui persiste, voir un concessionnaire autorisé.

SYMPTOMS	POSSIBLE CAUSES	WHAT TO DO
	6. Engine compression	As the engine is pulled over with the recoil starter, "cycles" of resistance should be felt as each piston goes past top dead center. If no pulsating resistance is felt, it suggests a major loss of compression. Contact your authorized dealer.
Engine lacks acceleration or power	1. Fouled or defective spark plug	Check item 5 of "Engine turns over but fails to start."
	2. Lack of fuel to engine	Check item 4 of "Engine turns over but fails to start."
	3. Carburetor adjustments	Contact your authorized dealer.
	4. Drive belt worn too thin	If the drive belt has lost more than 3 mm (1/8 in) of its original width, it will affect vehicle performance.
	5. Drive and driven pulleys require servicing	Contact your authorized dealer.
	6. Engine is overheating	If applicable, check coolant level ; check pressure cap ; check thermostat. Check for air locks in cooling system. If applicable, check fan belt and its tension ; clean cooling fins of engine ; if heating persists, contact your authorized dealer.

SYMPTOMS	POSSIBLE CAUSES	WHAT TO DO
Engine backfire	1. Faulty spark plug	See item 5 of "Engine turns over but fails to start."
	2. Water in fuel	Drain fuel system and refill with clean fuel.
	3. Engine is running too hot	See item 6 of "Engine lacks acceleration or power."
	4. Ignition timing is incorrect or there is an ignition system failure	Contact your authorized dealer.
Snowmobile cannot reach full speed	1. Drive belt	Check item 4 of "Engine lacks acceleration or power."
	2. Incorrect track adjustment	See maintenance section for proper alignment and tension settings.
	3. Pulleys misaligned	Contact your authorized dealer.
	4. Engine	See items 1, 2, 3 & 6 of "Engine lacks acceleration or power."

TOOLS

As standard equipment each new snowmobile is supplied with basic tools such as screwdriver, wrenches, emergency starting rope, etc.

Standard Tools

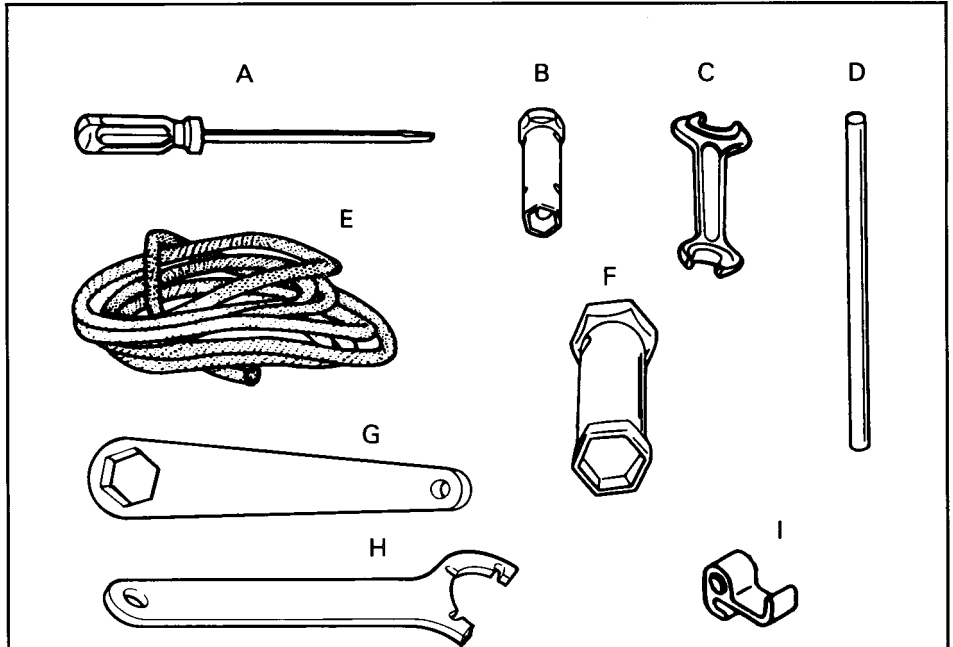

A001 001 068

DESCRIPTION

PART NUMBERS

A. Screwdriver	414 6424 00
B. Socket 10/13 mm	414 6426 00
C. Open end wrench 10/13 mm	414 6428 00
D. Socket wrench handle	414 6427 00
E. Starter rope	414 5001 00
F. Socket 21/26 mm	414 6425 00
G. Hexagonal wrench (adjuster blocks)	529 0024 00
H. Shock absorber spring collar adjustment key for rear suspension	529 0053 00
I. Emergency starter clip	420 8523 40

SPECIFICATIONS

	SAFARI L	SAFARI LE
ENGINE		
Type	377	377
No of cylinders	2	2
Bore	62 mm (2.441")	62 mm (2.441")
Stroke	61 mm (2.402")	61 mm (2.402")
Displacement	368.3 cm ³ (22.48 in ³)	368.3 cm ³ (22.48 in ³)
Compression ratio (corrected)	6.9:1	6.9:1
Maximum horsepower RPM*	6750 RPM	6750 RPM
Carburetor type	Variable venturi, float type	Variable venturi, float type
Carburetor adjustment :		
— air screw		
— idle speed	1800-2000 RPM	1800-2000 RPM
Fan belt deflection	9-10 mm (23/64"-25/64")	9-10 mm (23/64"-25/64")
CHASSIS		
Overall length	277 cm (109")	277 cm (109")
Overall width	103 cm (40.5")	103 cm (40.5")
Overall height	114 cm (45")	114 cm (45")
Ski stance (center to center)	92.1 cm (36.3")	92.1 cm (36.3")
Ski alignment (toe out)	3 mm (1/8")	3 mm (1/8")
Weight	204 kg (450 lb)	213 kg (470 lb)
Bearing area	6896 cm ² (1069 in ²)	6896 cm ² (1069 in ²)
Ground pressure	2.90 kPa (.420 lb/in ²)	3.03 kPa (.439 lb/in ²)
BRAKE		
Type	Disc, self-adjusting.	
Lining minimum thickness	Fixed pad must projects 1 mm (1/32") minimum from caliber.	
Control lever adjustment	13 mm (1/2") minimum distance from handlebar grip when fully applied.	

N.A. : Not applicable

*The maximum horse RPM is applicable with engine on the vehicle. It may be different under certain circumstances and Bombardier Inc. reserves the right to modify it without any obligation.

	SAFARI L	SAFARI LE
POWER TRAIN		
Track :		
– width	41.9 cm (16-1/2'')	41.9 cm (16-1/2'')
– length	315 cm (124'')	315 cm (124'')
– tension	40 mm (1-9/16 in) gap between slider shoe and bottom inside of track when exerting a downward pull of 7.3 kg (16 lb) to the track.	
– alignment	Equal distance between edges of track guides and slider shoes	
Standard gear ratio	20/44	20/44
Drive belt :		
– number	414 6175 00	414 6175 00
– maximum width	34.9 mm (1-3/8'')	34.9 mm (1-3/8'')
– minimum width	31.7 mm (1-1/4'')	31.7 mm (1-1/4'')
Chaincase oil	250 mL (9 oz)	250 mL (9 oz)
ELECTRICAL		
Lighting system (output)	12 V 160 W	12 V 160 W
Bulb :		
– headlamp	60/60 W	60/60 W
– tail/stop	5/21 W	5/21 W
– speedometer	5 W	5 W
– tachometer	N.A.	N.A.
– electric fuel gauge	N.A.	N.A.
Fuse :		
– tachometer	N.A.	N.A.
– starting system	N.A.	30 A
Spark plug :		
– type	NGK BR9ES	NGK BR9ES
– gap	0.45 mm (0.018'')	0.45 mm (.018'')
FUEL		
Gas type	Regular leaded or unleaded	
Fuel tank capacity :		
– SI	28.6 liters	28.6 liters
– U.S.	7.6 gallons	7.6 gallons
Injection oil	Bombardier snowmobile injection oil	
Tank capacity :		
– SI	2.4 liters	2.4 liters
– U.S.	81 oz	81 oz

N.A. : Not applicable

Bombardier Inc. reserves the right to make changes in design and specifications and/or to make additions to, or improvements in its product without imposing any obligation upon itself to install them on its products previously manufactured.

	SAFARI LX	SAFARI LXE
ENGINE		
Type	447	447
No of cylinders	2	2
Bore	67.5 mm (2.657")	67.5 mm (2.657")
Stroke	61 mm (2.402")	61 mm (2.402")
Displacement	436.5 cm ³ (26.6 po ⁵)	436.5 cm ³ (26.6 po ⁵)
Compression ratio (corrected)	6.3 : 1	6.3 : 1
Maximum horsepower RPM*	7000	7000
Carburetor type	Variable venturi, float type	Variable venturi, float type
Carburetor adjustment :		
— air screw		
— idle speed	1800-2000 tr/mn	1800-2000 tr/mn
Fan belt deflection	8-9 mm (5/16"-23/64")	8-9 mm (5/16"-23/64")
CHASSIS		
Overall length	277 cm (109")	277 cm (109")
Overall width	103 cm (40.6")	103 cm (40.6")
Overall height	114 cm (45")	114 cm (45")
Ski stance (center to center)	92.1 cm (36.3")	92.1 cm (36.3")
Ski alignment (toe out)	3 mm (1/8")	3 mm (1/8")
Weight	207 kg (456 lb)	219 kg (483 lb)
Bearing area	6896 cm ² (1069 po ²)	6896 cm ² (1069 po ²)
Ground pressure	2.94 kPa (.427 lb/po ²)	3.11 kPa (.451 lb/po ²)
BRAKE		
Type	Disc, self-adjusting.	
Lining minimum thickness	Fixed pad must projects 1 mm(1/32") minimum from caliber.	
Control lever adjustment	13 mm (1/2") minimum distance from handlebar grip when fully applied.	

N.A. : Not applicable

*The maximum horse RPM is applicable with engine on the vehicle. It may vary under certain circumstances and Bombardier Inc. reserves the right to modify it without any obligation.

	SAFARI LX	SAFARI LXE
POWER TRAIN		
Track :		
– width	41.9 cm (16-1/2'')	41.9 cm (16-1/2'')
– length	315 cm (124'')	315 cm (124'')
– tension	40 mm (1-9/16 in) gap between slider shoe and bottom inside of track when exerting a downward pull of 7.3 kg (16 lb) to the track.	
– alignment	Equal distance between edges of track guides and slider shoes	
Standard gear ratio	22/44	22/44
Drive belt :		
– number	414 6175 00	414 6175 00
– maximum width	34.9 mm (1-3/8'')	34.9 mm (1-3/8'')
– minimum width	31.7 mm (1-1/4'')	31.7 mm (1-1/4'')
Chaincase oil	250 mL (9 oz)	250 mL (9 oz)
ELECTRICAL		
Lighting system (output)	12 V 160 W	12 V 160 W
Bulb :		
– headlamp	60/60 W	60/60 W
– tail/stop	5/21 W	5/21 W
– speedometer	5 W	5 W
– tachometer	5 W	5 W
– electric fuel gauge	2 W	2 W
Fuse :		
– tachometer	0.1 A	0.1 A
– starting system	N.A.	30 A
Spark plug :		
– type	NGK BR9ES	NGK BR9ES
– gap	0.45 mm (.018'')	0.45 mm (.018'')
FUEL		
Gas type	Regular leaded or unleaded	
Fuel tank capacity :		
– SI	36 liters	36 liters
– U.S.	9 gallons	9 gallons
Injection oil	Bombardier snowmobile injection oil	
Tank capacity :		
– SI	2.4 liters	2.4 liters
– U.S.	81 oz	81 oz

N.A. : Not applicable

Bombardier Inc. reserves the right to make changes in design and specifications and/or to make additions to, or improvements in its product without imposing any obligation upon itself to install them on its products previously manufactured.

	SAFARI LCE	SAFARI GLX
ENGINE		
Type	467	467
No of cylinders	2	2
Bore	69.5 mm (2.736")	69.5 mm (2.736")
Stroke	61.0 mm (2.402")	61.0 mm (2.402")
Displacement	462.8 cm ³ (28.24 po ³)	462.8 cm ³ (28.24 po ³)
Compression ratio (corrected)	7.5 : 1	7.5 : 1
Maximum horsepower RPM		
Carburetor type	Variable Venturi, float type	Variable Venturi, float type
Carburetor adjustment :		
- air screw		
- idle speed	1800-2000 tr/mn	1800-2000 tr/mn
Cooling system capacity :		
- SI		
- Imp.		
- É. - U.		
Antifreeze/ water mixture (% by volume)	60/40	60/40
Thermostat	43°C (110°F)	43°C (110°F)
Radiator pressure cap	90 kPa (13 lb/po ²)	90 kPa (13 lb/po ²)
CHASSIS		
Lenght overall	277 cm (109")	269 cm (106")
Width overall	103 cm (40.6")	103 cm (40.6")
Height overall	114 cm (45")	114 cm (45")
Ski stance (center to center)	92.1 cm (36.3")	92.1 cm (36.3")
Weight	234 kg (516 lb)	253 kg (558 lb)
Bearing area	6896 cm ² (1069 po ²)	6896 cm ² (1069 po ²)
Ground pressure	3.33 kPa (.482 lb/po ²)	3.60 kPa (.521 lb/po ²)
BRAKE		
ALL MODELS		
Type	Disc, self-adjusting	
Lining minimum thickness	Fixed pad must project 1 mm (1/32 in) minimum from caliper.	
Control lever adjustment	13 mm (1/2 in) minimum distance from handlebar grip when fully applied.	

N.A. : Not applicable

*The maximum horse power RPM is applicable with engine on the vehicle. It may vary under certain circumstances and Bombardier Inc. reserves the right to modify it without any obligation.

	SAFARI LCE	SAFARI GLX
POWER TRAIN		
Track :		
– width	41.9 cm (16-1/2'')	41.9 cm (16-1/2'')
– length	315 cm (124'')	315 cm (124'')
– tension	40 mm (1-9/16 in) gap between slider shoe and bottom inside of track when exerting a downward pull of 7.3 kg (16 lb) to the track.	
– alignment	Equal distance between edges of track guides and slider shoes	
Standard ratio		
Drive belt :		
– number	414 6338 00	414 6338 00
– maximum width	34.9 mm (1-3/8'')	34.9 mm (1-3/8'')
– minimum width	31.7 mm (1-1/4'')	31.7 mm (1-1/4'')
Chaincase oil	500 mL (18 oz)	500 mL (18 oz)
ELECTRICAL		
Lighting system (output)	12 V 160 W	12 V 160 W
Bulb :		
– headlamp	60/55 W H4 Hal.	60/55 W H4 Hal.
– tail/stop	5/21 W	5/21 W
– speedometer	5 W	5 W
– tachometer	5 W	5 W
– temperature gauge	2 W	2 W
– electric fuel gauge	2 W	2 W
Fuse :		
– tachometer	0.1 A	0.1 A
– starting system	30 A	30 A
Spark plug :		
– type	NGK BR9ES	NGK BR9ES
– gap	0.45 mm (.016 po)	0.4 mm (.016 po)
FUEL		
Gas type	Regular unleaded	
Fuel tank capacity :		
– SI	36 L	36 L
– Imp.	8 gal	8 gal
– U.S.	9 gal	9 gal
Injection oil	Bombardier Snowmobile Injection Oil	
Tank capacity :		
– SI	2.4 L	2.4 L
– Imp.	85 oz	85 oz
– É.-U.	81 ounces	81 ounces

Hal. : Halogen

N.A. : Not applicable

Bombardier Inc. reserves the right to make changes in design and specifications and/or to make conditions to, or improvements in its product without imposing any obligation upon itself to install them on its products previously manufactured.

SI* METRIC INFORMATION GUIDE

BASE UNITS

DESCRIPTION	UNIT	SYMBOL
length	meter	m
mass	kilogram	kg
force	Newton	N
liquid	liter	L
temperature	Celsius	°C
pressure	kilopascal	kPa
torque	Newton meter	N•m
speed	kilometer per hour	km/h

PREFIXES

PREFIX	SYMBOL	MEANING	VALUE
kilo	k	one thousand	1000
centi	c	one hundredth	0.01
milli	m	one thousandth	0.001
micro	μ	one millionth	0.000 001

CONVERSION FACTORS

TO CONVERT	TO †	MULTIPLY BY
in	mm	25.4
in	cm	2.54
in ²	cm ²	6.45
in ³	cm ³	16.39
ft	m	0.3
oz	g	28.35
lb	kg	0.45
lbf	N	4.4
lbf•in	N•m	0.11
lbf•ft	N•m	1.36
lbf•ft	lbf•in	12
PSI	kPa	6.89
imp. oz	U.S. oz	0.96
imp. oz	mL	28.41
imp. gal	U.S. gal	1.2
imp. gal	L	4.55
U.S. oz	mL	29.57
U.S. gal	L	3.79
MPH	km/h	1.61
Fahrenheit	Celsius	(°F - 32) ÷ 1.8
Celsius	Fahrenheit	(°C × 1.8) + 32

*The international system of units abbreviates "SI" in all languages.

†To obtain the inverse sequence, divide by the given factor. To convert "mm" to "in", divide by 25.4.

NOTES
