

ALPINE® II **OPERATOR'S MANUAL**

SUPPLEMENT FOR MODEL : 3350
This correction sheet must be used in conjunction with the *1990 Alpine II operator's manual* (P/N 414 6786 00)

1990



BOMBARDIER

snowmobiles

**SERVICE PROCEDURE
PRIOR TO OPERATION**

MODEL : 1990 ALPINE® II (Military version)
VEHICLE CODE : 3350

BATTERY

1. Remove battery from vehicle.
2. Remove the sealing tube from battery vent elbow.

◆ **WARNING : Failure to remove the sealing tube could result in an explosion.**

3. Remove caps and fill battery to the UPPER LEVEL line with electrolyte (specific gravity : 1.260 at 20°C (68°F)).
4. Allow battery to stand for 30 minutes MINIMUM so that electrolyte soak through battery cells.
5. Readjust electrolyte level to the UPPER LEVEL line.
6. Charge battery at a rate not exceeding 2.0 amperes for 10 to 20 hours checking state of charge frequently.

▼ **CAUTION : If charging rate exceeds 2.4 amps. reduce immediately. If cell temperature rises above 50°C (122°F) (if the casing feels hot) discontinue charging temporarily and/or reduce the charging rate.**

◆ **WARNING : Gases given off by a battery being charged are highly explosive. Always charge in a well ventilated area. Do not smoke or allow open flame or spark in vicinity. Always turn battery charger off **prior to** disconnecting cables. Otherwise a spark will occur and battery might explode.**

7. After charging, allow the gas bubbles to escape by lightly shaking battery by hand. Let it settle for about one hour.
8. Readjust electrolyte level to the UPPER LEVEL line if required.
9. Reinstall battery caps and wipe off any spillage using a solution of baking soda and water.

▼ **CAUTION : Do not allow baking soda and water solution to enter battery cells and contaminate electrolyte.**

10. Connect one end of vent tube to the battery vent elbow and route other end through hole in bottom pan.

◆ **WARNING : Vent tube must be free and open. A kinked or bent tube will restrict ventilation and create gas accumulation that could result in an explosion.**

11. Secure battery to rack and connect terminals.

▼ **CAUTION : Battery negative (–) terminal must always be disconnected **first** and reconnected **last**.**

WINDSHIELD

Carefully peel off protective film from windshield.

Position windshield on cab, over locating slots. Push down until tabs are fully inserted in slots and lock, from inside cab, using special o-rings (8) supplied.

 **WARNING** : The engine and the corresponding components identified in the operator's manual should not be utilized on product(s) other than that mentioned on the cover page of the operator's manual.

CONTROLS/INSTRUMENTS

Seat compartment

Unfasten spring catch and tip seat over from right side. Two jacks and a spare drive belt are hold by brackets on left side of seat compartment, note their positions for proper storage. Two spare spark plugs are screwed on a support on right side of seat compartment. The storage cover is also located in seat compartment.

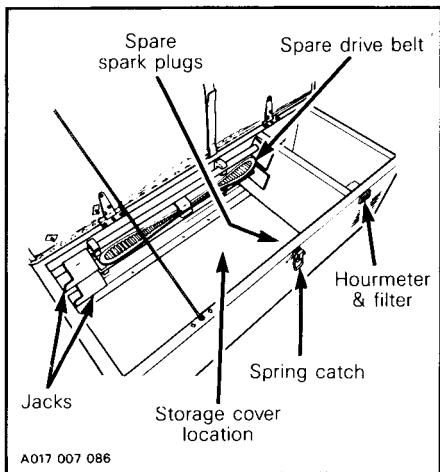

Hour meter

The hour meter and its filter are located in battery compartment at front of seat compartment. The hour meter indicates the total number of engine running hours.

Ski tie downs

On each side of rack, two ski tie downs are riveted.

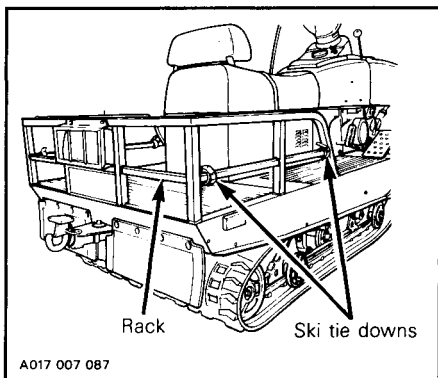

Jack utilization

Install jacks as illustrated to support rear portion of vehicle off the ground.

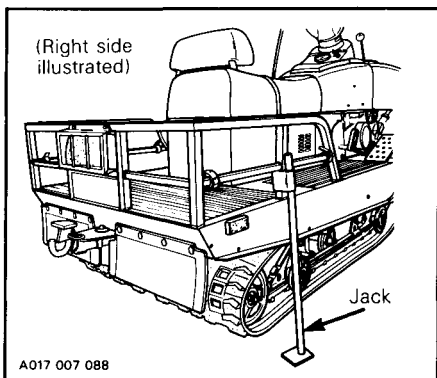

TOOLS

As standard equipment each new snowmobile is supplied with basic tools such as screwdriver, wrenches, emergency starting rope, etc.

Standard Tools

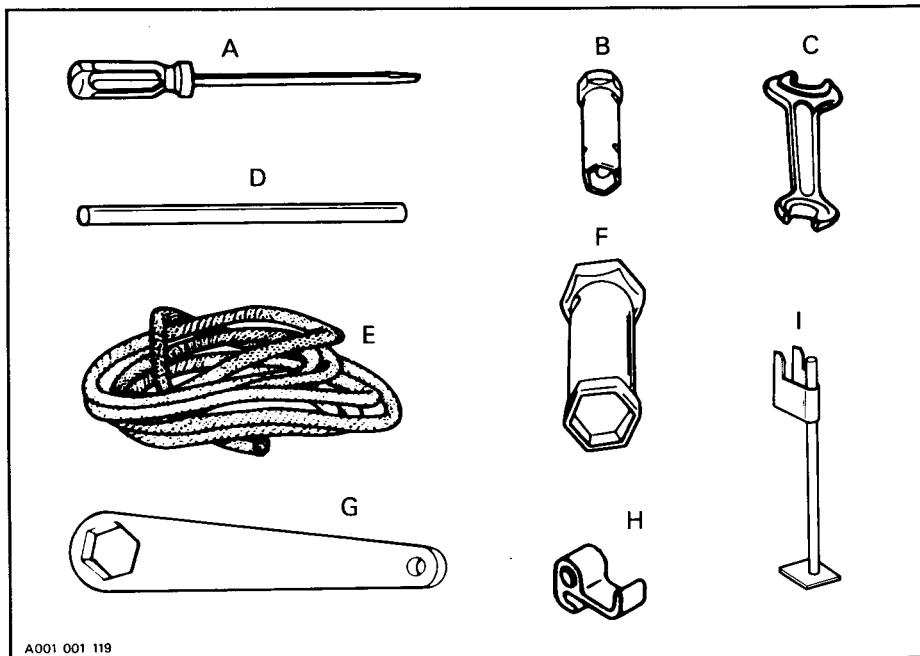

A001 001 119

- | | |
|-----------------------------|--|
| A. Screwdriver | F. Socket 21/26 mm |
| B. Socket 10/13 mm | G. Hexagonal wrench
(adjuster blocks) |
| C. Open end wrench 10/13 mm | H. Emergency starter clip |
| D. Socket wrench handle | I. Jack (2) |
| E. Emergency starting rope | |

WIRING DIAGRAM

Alpine II military

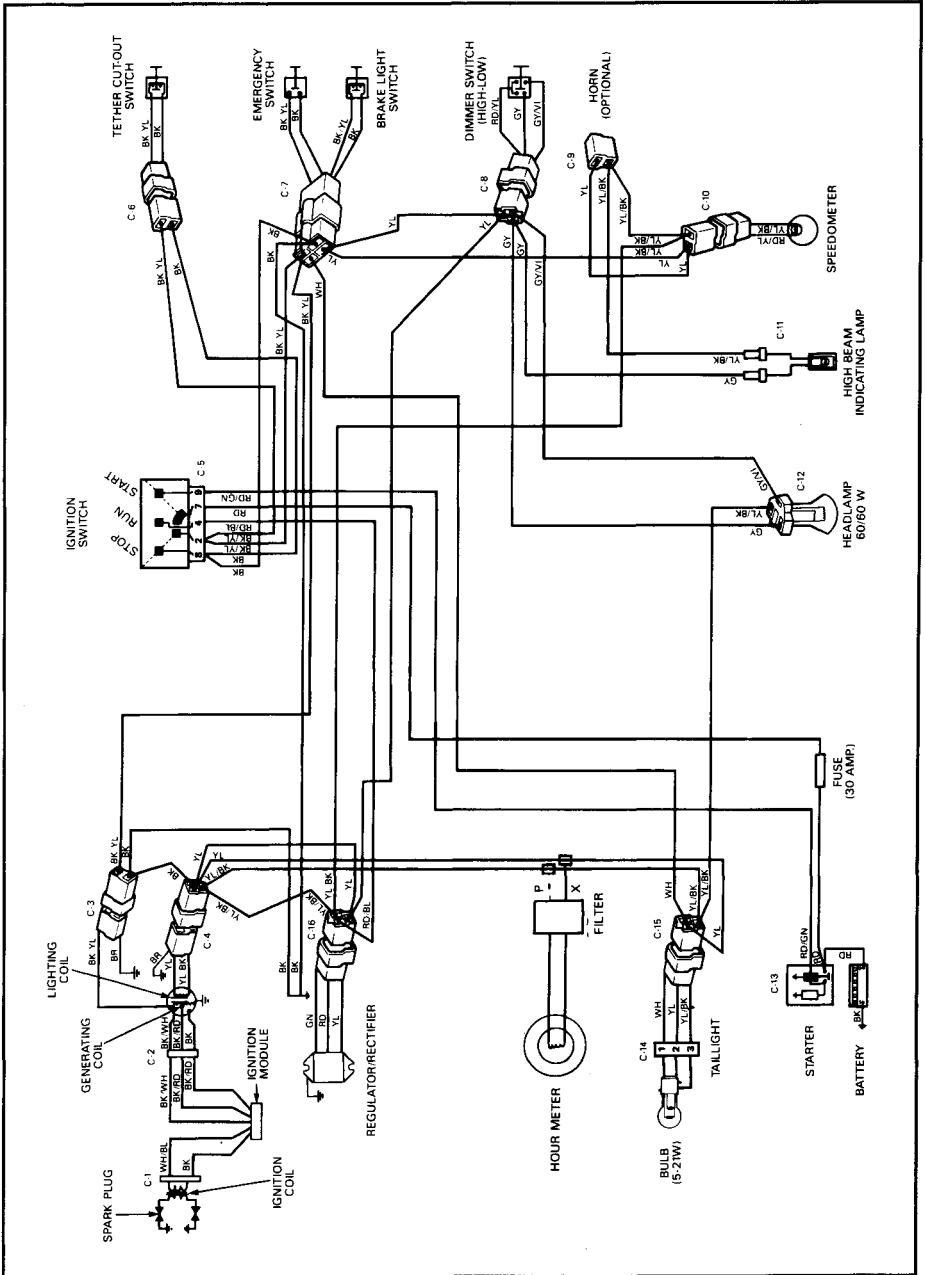

LOCATION OF CONNECTORS

C-1, C-2, C-3, C-4 : On engine, right side

C-5, C-6, C-7, C-8, C-9, C-10, C-11 :
Underneath dashboard

C-12 : Near headlamp

C-13 : Near electric starter

C-14 : On taillight housing

C-15 : Under carburetor

C-16 : Near regulator/rectifier

COLOUR CODES	
BK – BLACK	GN – GREEN
WH – WHITE	GY – GREY
RD – RED	VI – VIOLET
BL – BLUE	OR – ORANGE
YL – YELLOW	BR – BROWN