

operator's manual

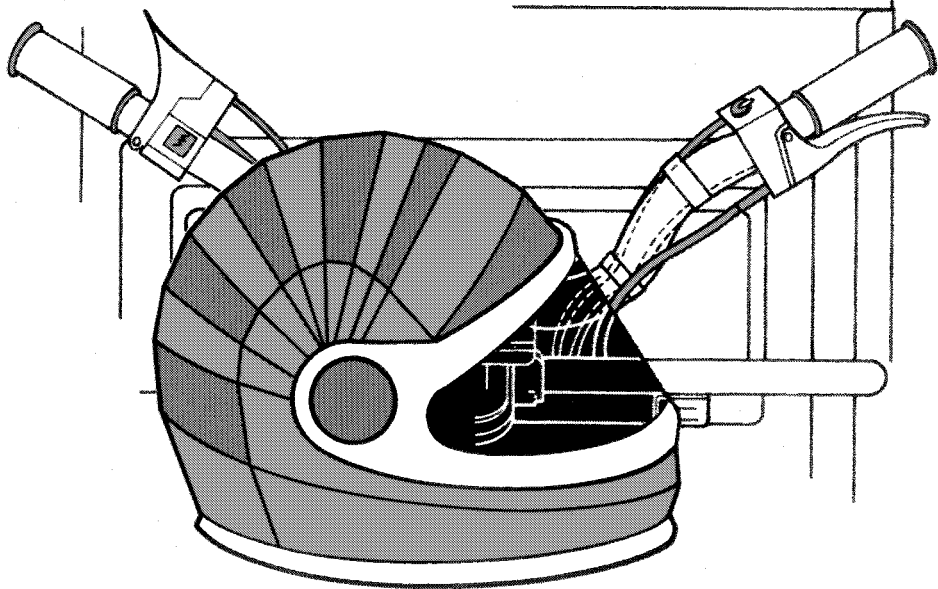

FORMULA*
MX/MX LT
PLUS/PLUS LT



1989

model _____

V.I.N. _____

purchase date _____

warranty expiry date _____

To be completed by dealer at time of sale

DEALER IMPRINT AREA

AFTER-SALES SERVICE
BOMBARDIER INC.
VALCOURT, QUEBEC
CANADA, JOE 2LO



The following are trademarks of Bombardier Inc.

ALPINE®	FORMULA *	SAGA *
BLIZZARD®	FUTURA®	SCOUT *
BOMBARDIER®	GRAND PRIX SPÉCIAL®	SKANDIC®
CARRY-BOOSE®	MIRAGE®	SKI-DOO®
CHEYENNE *	MOTO-SKI®	SONIC®
CITATION®	NORDIK®	SPIRIT®
ÉLAN®	NUVIK®	STRATOS *
ÉLITE®	OLYMPIQUE®	T'NT®
ESCAPADE *	ROTAX®	TUNDRA *
EVEREST®	SAFARI *	VOYAGEUR *

FOREWORD

The operator manual and the SSCC Snowmobiler's Safety Handbook have been prepared to acquaint the owner/operator or passenger of a new snowmobile with the various vehicle controls, maintenance and safe operating instructions. Each is indispensable for the proper use of the product, and should be kept with the vehicle at all times.

Should you have any questions pertaining to the warranty and its application, please consult the "Often Asked Question" section of this manual, or your authorized dealer.

This manual uses the following symbols.

 **WARNING:** Identifies an instruction which, if not followed, could cause serious personal injuries including possibility of death.

 **CAUTION:** Denotes an instruction which, if not followed, could severely damage vehicle components.

 **NOTE:** Indicates supplementary information needed to fully complete an instruction.

Although the mere reading of such information does not eliminate the hazard, your understanding of the information will promote its correct use.

The information and components/system descriptions contained in this manual are correct at time of publication. Bombardier Inc. however, maintains a policy of continuous improvement of its products without imposing upon itself any obligation to install them on products previously manufactured.

Bombardier Inc. reserves the right at any time to discontinue or change specifications, designs, features, models or equipment without incurring obligation.

The illustrations show the typical construction of the different assemblies and, in all cases, may not reproduce the full detail or exact shape of the parts shown, however, they represent parts which have the same or a similar function.

Most specifications are given in both metric and customary units. Where precise accuracy is not required, some conversions are rounded off for easier use.

A shop manual can be obtained for complete service, maintenance and repair information.

 **WARNING:** The engines and the corresponding components identified in this manual should not be utilized on product(s) other than those mentioned on the cover page of this manual.

 **WARNING:** Maintenance procedures and tightening torques must be strictly adhered to, never attempt repairs unless the appropriate tools are available.

 **CAUTION:** Most components of this vehicle are built with parts dimensioned in the metric system. Most fasteners are metric and must not be replaced by customary fasteners or vice versa. Mismatched or incorrect fasteners could cause damage to the vehicle or possible personal injury.

SAFETY MEASURES

Observe the following precautions:

- Throttle mechanism should be checked for free movement before starting engine.
- Do not operate vehicle near snow making equipment.
- The snowmobile engine can be stopped by activating the emergency cut-out or tether switches or turning off the key.
- Clean and check operation of the headlight, tail light and brake light.
- Engine should be running only when belt guard and/or pulley guard is secured in place.
- Never run the engine without drive belt installed. Running an unloaded engine can prove to be dangerous.
- Never run the engine when the track is raised off the ground.
- It can be dangerous to run engine with the hood removed.
- Gasoline is flammable and explosive under certain conditions. Always manipulate in a well ventilated area. Do not smoke or allow open flames or sparks in the vicinity. If gasoline fumes are noticed while driving, the cause should be determined and corrected without delay.
- Maintain your vehicle in top mechanical condition at all times.
- Your snowmobile is not designed to be driven or operated on black top, bare earth, or other abrasive surfaces. On such surfaces abnormal and excessive wear of critical parts is inevitable.
- Your snowmobile is not designed to be operated on public streets, road or highways. In most States and Provinces, it is considered an illegal operation.
- Installation of other than standard equipment, including ski-spreaders, bumpers, pack racks, etc., could severely affect the stability and safety of your vehicle. Avoid adding on accessories that alter the basic vehicle configuration.
- Whenever the vehicle is parked outdoors, overnight or for a long period, it is suggested to protect it against the inclemency of the weather with a snowmobile cover.
- Do not lubricate throttle and/or brake cables and housings.
- Only perform procedures as detailed in this manual. Unless otherwise specified, engine should be turned OFF for all lubrication and maintenance procedures.
- Since engine cooling is fully in effect only when the vehicle is in motion and driven on snow, it is not recommended that you allow the engine to idle for more than brief periods and/or you drive the vehicle on icy surfaces. Prolonged idling and/or continuous driving on ice may cause engine damage.
- When removing coolant tank cap, first place a cloth over cap then turn cap to its first step to release pressure. Never drain or refill the cooling system when engine is hot.
- These vehicles are designed for the driver only. No provisions have been made for a passenger.
- The performance of these vehicles may significantly exceed that of other snowmobiles you have operated. Therefore, use of this vehicle by novice or inexperienced operators is not recommended.
- Should removal of a locking device be required when undergoing repairs/disassembly, always replace by new ones. Tighten fasteners as specified in the applicable Shop Manual.

PLEASE READ AND UNDERSTAND ALL WARNINGS AND CAUTIONS IN THE SNOWMOBILER'S SAFETY HANDBOOK, THE OPERATOR'S MANUAL AND ON THE VEHICLE

BOTH MANUALS SHOULD REMAIN WITH THE VEHICLE AT THE TIME OF RESALE

INDEX

THE 1989 SNOWMOBILE LIMITED WARRANTY	4
OFTEN ASKED QUESTIONS	6
LISTING OF AREA DISTRIBUTORS	8
HOW TO IDENTIFY YOUR SNOWMOBILE	9
CONTROLS/INSTRUMENTS	
Throttle lever, brake lever, ignition light switch, headlamp dimmer switch, emergency cut-out switch, tether cut-out switch, rewind starter handle, primer, adjustable steering handle, speedometer, tachometer, temperature gauge, injection oil level pilot lamp, high beam pilot lamp, tank cap, electric fuel level gauge, hood latch, tool bag, spark plug holder, fuse holder, spare drive belt holder, fuel shut-off valve, rear bumper, accessories	10
BREAK-IN PERIOD	
Engine, belt, 10-hour inspection, 10-hour inspection check list	17
FUEL & OIL	
Recommended gasoline, recommended oil, oil injection system	19
PRE-START CHECK	
Check points	20
STARTING PROCEDURE	
Manual starting, before riding, emergency starting	21
LUBRICATION	
Frequency, steering and front suspension mechanism, drive axle, countershaft (brake disc and driven pulley), slide suspension, chaincase oil level, oil injection system, rotary valve system	23
MAINTENANCE	
Service and maintenance chart, belt guard removal, drive belt removal and installation, drive belt condition, new drive belt, brake condition, brake adjustment, spark plugs, suspension condition, suspension adjustment, limiter screw, track condition, track tension and alignment, drive pulley, drive chain tensionner, steering and front suspension mechanism, steering and ski leg camber adjustment, muffler attachment, engine head nuts, engine mount screws, air filter, carburetor adjustment, high altitude kit, oil injection system, cooling system, headlamp beam aiming, bulb replacement, general inspection	29
STORAGE	
Track, suspension, skis and runners, controls, chaincase, drive pulley, countershaft (brake disc and driven pulley), cooling system, engine lubrication, driven pulley, fuel tank and carburetors, chassis, general inspection	41
PRE-SEASON PREPARATION	
Pre-season preparation chart	46
TROUBLE SHOOTING	47
TOOLS	49
SPECIFICATIONS	50
SI METRIC INFORMATION GUIDE	54

THE 1989 SNOWMOBILE LIMITED WARRANTY _____

1 - PERIOD

BOMBARDIER INC. as manufacturer, warrants FROM THE DATE OF DELIVERY TO THE FIRST CONSUMER, every 1989 BOMBARDIER® snowmobile, sold as NEW AND UNUSED, and predelivered by an authorized BOMBARDIER® dealer for a period of:

- 12 consecutive months.

2 - WHAT BOMBARDIER INC. WILL DO

BOMBARDIER INC. will repair and/or replace, at its option, components defective in material and/or workmanship (under normal use and service), with a genuine BOMBARDIER® component without charge for parts or labour, at any authorized BOMBARDIER® dealer during said warranty period.

3 - CONDITION TO HAVE WARRANTY WORK PERFORMED

Present to the servicing dealer, the hard copy of the BOMBARDIER® Warranty Registration card or proof of purchase received by the customer from the selling dealer at time of delivery.

4 - WARRANTY TRANSFER

This warranty is transferable to subsequent owner(s) for remainder of warranty period from original date of delivery.

5 - EXCLUSIONS - ARE NOT WARRANTED

- Normal wear on all items such as, but not limited to:
 - drive belts
 - bulbs
 - slider shoes
 - runners on skis
 - spark plugs
- Replacement parts and/or accessories which are not genuine BOMBARDIER® parts and/or accessories.
- Damage resulting from installation of parts other than genuine BOMBARDIER® parts.
- Damage caused by failure to provide proper maintenance as detailed in the Operator's Manual. The labour, parts and lubricants costs of all maintenance services, including tune-ups and adjustments will be charged to the owner.
- Vehicles designed and/or used for racing purposes.
- All optional accessories installed on the vehicle. (The normal warranty policy for parts and accessories, if any, applies).
- Damage resulting from accident, fire or other casualty, misuse, abuse or neglect.
- Damage resulting from operation of the snowmobile on surfaces other than snow.
- Damage resulting from modification to the snowmobile not approved in writing by BOMBARDIER INC.
- Losses incurred by the snowmobile owner other than parts and labour, such as, but not limited to, transportation, towing, telephone calls, taxis, or any other incidental or consequential damage.

6 - BATTERY WARRANTY:

- 12 consecutive months. (Pro-rated)

100% warranty coverage will start on the date the snowmobile was delivered and run to the following April 30th. The remainder of the 12 month-period will be pro-rated as follows:

- 50% from April 30th to December 1st.
- 40% from December 1st to December 31st.
- 30% from January 1st to end of warranty.

7 - EXPRESSED OR IMPLIED WARRANTIES

This warranty gives you specific rights and you may also have other legal rights which may vary from state to state, or province to province. Where applicable this warranty is expressly in lieu of all other expressed or implied warranties of BOMBARDIER INC., its distributors and the selling dealer, including any warranty of merchantability or fitness for any particular purpose; otherwise the implied warranty is limited to the duration of this warranty. However, some states or provinces do not allow limitations on how long an implied warranty lasts, so the above limitation may not apply.

Neither the distributor, the selling dealer, nor any other person has been authorized to make any affirmation, representation or warranty other than those contained in this warranty, and if made, such affirmation, representation or warranty shall not be enforceable against BOMBARDIER INC. or any other person.

Some states or provinces do not allow the exclusion or limitation of incidental or consequential damages, so the above limitation or exclusion may not apply.

BOMBARDIER INC. reserves the right to modify its warranty policy at any time, being understood that such modification will not alter the warranty conditions applicable to vehicles sold while the above warranty is in effect.

8 - CONSUMER ASSISTANCE

If a servicing problem or other difficulty occurs, we suggest the following:

1. Try to solve the problem at the dealership with the Service Manager or Owner.
2. If this fails, contact your area distributor listed in the Operator's Manual.
3. Then if your grievance still remains unsolved, you may write to us:

Bombardier Inc.
Service Department
Snowmobile Division
Valcourt (Quebec), Canada JOE 2L0

September 1987
Bombardier Inc.
Valcourt (Quebec), Canada JOE 2L0

®*Trademarks of Bombardier Inc.

OFTEN ASKED QUESTIONS

Q: Why must my snowmobile be registered at the factory? After all I do have my original invoice as proof of when I purchased my snowmobile.

A: Your warranty is valid at any authorized dealer of the product. Your registration is the key element in providing the servicing dealer with the necessary data to complete warranty claim forms. This information is also used to notify owners in the event of a safety recall.

Q: Who should send the registration card to Bombardier Inc.?

A: The authorized dealer. However, it is important that the customer make sure that it has been sent. The company might contact you should your vehicle be recalled or in case of a particular warranty campaign.

Q: I bought my snowmobile in O'King County but I snowmobile in Washington County. Can the dealer in Washington County accept to perform warranty work on my snowmobile?

A: Yes, any authorized dealer in North America can perform warranty repairs, providing the customer warranty registration card is presented.

Q: Where can I find information on the lubrication and maintenance of my snowmobile?

A: In this Operator Manual provided with the vehicle at the time of delivery.

Q: Will the entire warranty be void or cancelled, if I do not operate or maintain my new snowmobile exactly as specified in the Operator's Manual?

A: The warranty of the new snowmobile cannot be "Voided" or "Cancelled". However, if a particular failure is caused by operation or maintenance other than is shown in the Operator Manual, THAT failure may not be covered under warranty. This includes service work performed by the customer, especially the critical adjustments to ignition, timing, carburation and oil injection/or oil mixture.

Q: Would you give some examples of abnormal use or strain, neglect or abuse?

A: These terms are general and overlap each other in areas. Some specific examples may include: running the machine out of oil, chain failure caused by a lack of lubrication, operating the machine with a broken or damaged part which causes another part to fail, and so on. If you have any specific questions on operation or maintenance, please contact your dealer for advice.

Q: What costs are my responsibility during the warranty period?

A: The customer's responsibility includes all costs of normal maintenance services, non-warranty repairs, accidents and collision damage, as well as oils, and spark plugs, and incidental or consequential damage costs as explained in the warranty.

Q: Are "Genuine" Bombardier replacement parts used in warranty repairs covered by warranty?

A: Yes. When installed by an authorized dealer, any "Genuine" Bombardier part used in warranty repairs assumes the remaining warranty that exists on the machine.

Q: If I sell my snowmobile within the warranty period, will the new owner qualify for the balance of the warranty?

A: Yes, provided the unit has already been registered with the manufacturer. Note that the change of ownership card in this manual should be completed and sent to Bombardier Inc.

Q: How can I receive the best owner assistance?

A: The satisfaction and goodwill of the owners of Bombardier products are of primary concern to your authorized dealer and Bombardier Inc. Normally, any problems that arise in connection with the sales transaction or the operation of your snowmobile will be handled by your Dealers Sales or Service Departments. It is recognized, however, that despite the best intentions of everyone concerned, misunderstandings will sometimes occur. If you have a problem that has not been handled to your satisfaction through normal channels, we suggest that you discuss your problem with a member of dealership management. Frequently, complaints are the result of a breakdown in communications and can quickly be resolved by a member of the dealership management. If the problem already has been reviewed with the Sales Manager or Service Manager, contact the Dealer himself or the General Manager.

LISTING OF AREA DISTRIBUTORS

CANADIAN DISTRIBUTORS

PROVINCE OF QUEBEC

SERVICE OFFICE

BOMBARDIER INC.
Valcourt (Quebec) JOE 2L0
(514) 532-2211

SALES OFFICE

BOMBARDIER INC.
1350 Nobel Street
Boucherville (Quebec) J4B 1A1
(514) 655-6121

PROVINCE OF ONTARIO

SERVICE AND SALES OFFICE

BOMBARDIER INC.
230 Bayview Drive
Barrie (Ontario) L4N 5E9
(705) 728-8600

ATLANTIQUE REGION

SERVICE OFFICE

BOMBARDIER INC.
P.O. Box 7060
Riverview (New Brunswick) E1B 1V0
(506) 386-6117

SALES OFFICE

BOMBARDIER INC.
1350 Nobel Street
Boucherville (Quebec) J4B 1A1
(514) 655-6121

ALBERTA, BRITISH COLUMBIA, MANITOBA, SASKATCHEWAN, YUKON

SERVICE AND SALES OFFICE

BROOKS EQUIPMENT LIMITED
1616 King Edward Street
P.O. Box 985
Winnipeg (Manitoba) R3C 2V8
(204) 633-7247

NEWFOUNDLAND, LABRADOR

SERVICE AND SALES OFFICE

CHARLES R. BELL LIMITED
Riverside Drive
P.O. Box 1050
Corner Brook (Newfoundland) A2H 6J7
(709) 634-3533

NORTH-WEST TERRITORIES, FRANKLIN DISTRICT & KEEWATIN

SERVICE AND SALES OFFICE

HUDSON'S BAY CO. LIMITED
165 Hymus Blvd
Pointe-Claire (Quebec) H9R 1G2
(514) 630-5279

AMERICAN DISTRIBUTORS

EAST-CENTRAL, CENTRAL, WESTERN REGION

SALES OFFICE

BOMBARDIER CORPORATION
7575 Packer Drive
P.O. Box 8035
Wausau, Wisconsin 54402-8035
U.S.A.
(715) 842-8886

EAST-CENTRAL, CENTRAL REGION

SERVICE OFFICE

BOMBARDIER CORPORATION
4505 West Superior Street
P.O. Box 16106
Duluth, Minnesota 55816-0106
U.S.A.
(218) 628-2881

WESTERN REGION

SERVICE OFFICE

BOMBARDIER CORPORATION
P.O. Box 1569
Idaho Falls, Idaho 83403
U.S.A.
(208) 529-9510

EASTERN REGION

SERVICE AND SALES OFFICE

BOMBARDIER CORPORATION
East Main Street Road
Malone, New York 12953
U.S.A.
(518) 483-4411

ALASKA

SERVICE AND SALES OFFICE

THE BRYANT CORPORATION
NE. 190th & Woodinville
Snohomish Road
P.O. Box 389
Woodinville, Wa 98072
U.S.A.
(206) 482-0110

HOW TO IDENTIFY YOUR SNOWMOBILE

The main components of your snowmobile (engine, track and frame) are identified by different serial numbers. It may sometimes become necessary to locate these numbers for warranty purposes or to trace your snowmobile in the event of theft.

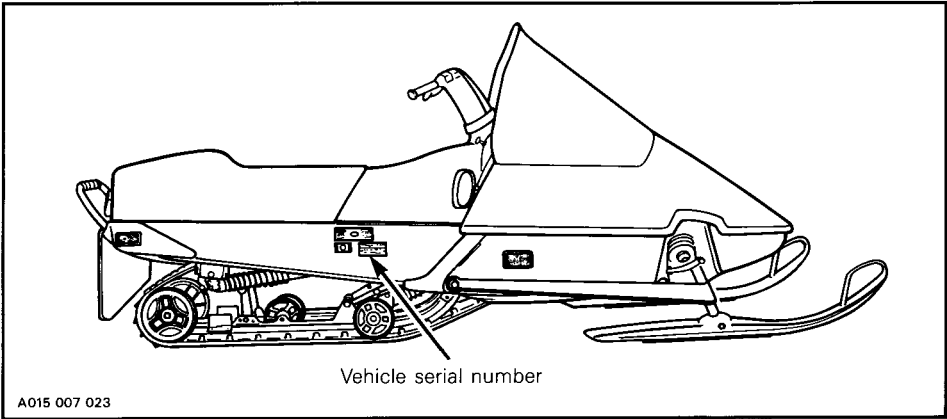
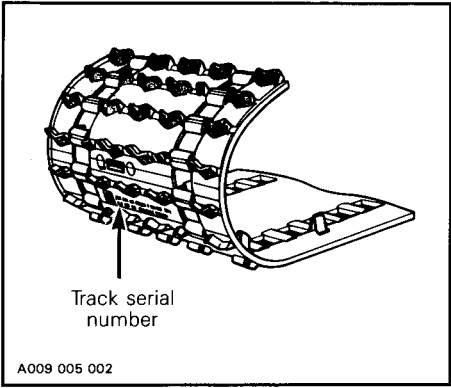
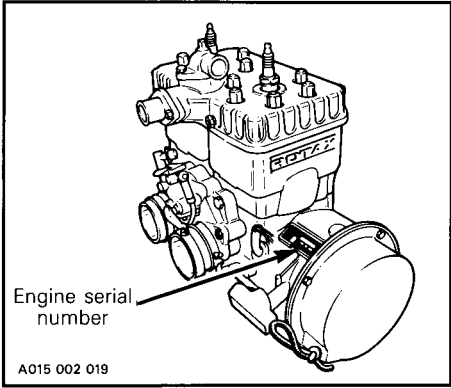

NOTE: We strongly recommend that you take note of all the serial numbers on your vehicle and supply them to your insurance company. It will surely help in the event your snowmobile is stolen.

CONTROLS/ INSTRUMENTS

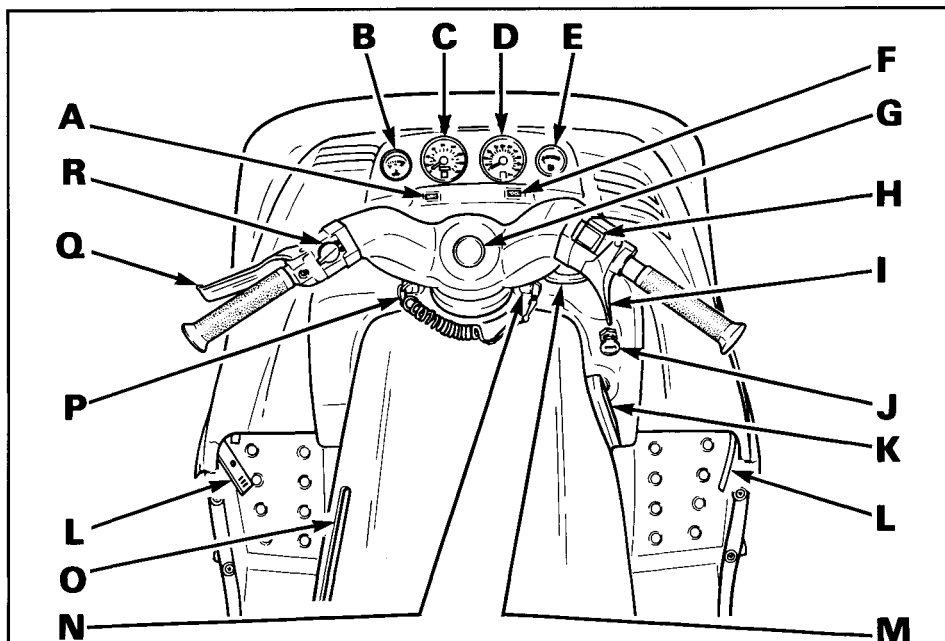

A015 007 046

- A) High Beam Pilot Lamp (blue)
- B) Temperature Gauge
- C) Speedometer
- D) Tachometer*
- E) Electric Fuel Gauge*
- F) Injection Oil Level Pilot Lamp (red)
- G) Adjustable Steering Handle
- H) Emergency Cut-out Switch
- I) Throttle Lever

- J) Primer
- K) Rewind Starter Handle
- L) Hood Latch
- M) Fuel Tank Cap
- N) Ignition/Light Switch
- O) Fuel Level Indicator (MX/MX LT only)
- P) Tether Cut-out Switch
- Q) Brake Lever
- R) Headlamp Dimmer Switch

* Optional for MX/MX LT

A) High Beam Pilot Lamp (Blue)

Lights up when headlamp is on high beam.

B) Temperature Gauge

The gauge indicates engine coolant temperature. Normal operating temperature is from 50° to 100°C (120° – 212°F).

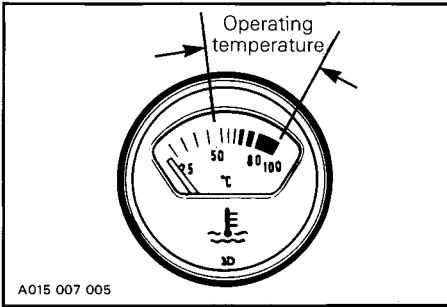

However, coolant temperature can vary according to driving conditions. If coolant temperature exceeds 100°C (212°F) reduce speed and run vehicle in loose snow or stop engine immediately.

◆ **WARNING:** To remove coolant tank cap, place a cloth over the cap and unscrew it to the first stop to release the pressure. If this notice is disregarded loss of fluid and severe burns could occur.

C) Speedometer

The speedometer is linked directly to the drive axle. Direct-reading dial indicates the speed of the vehicle.

Odometer records the total distance travelled in kilometers.

D) Tachometer

The tachometer registers the impulses of magneto. Direct-reading dial indicates the number of revolutions per minute (RPM) of the engine.

▼ **CAUTION:** The tachometer is protected by a fuse, if tachometer stops operating check fuse condition and if necessary replace. The fuse is 0.1 amp. Do not use a higher rated fuse as this can cause severe damage to the tachometer.

E) Electric Fuel Level Gauge

The electric fuel gauge is located in the dashboard and allows driver to observe the fuel level while riding the snowmobile.

F) Injection Oil Level Pilot Lamp (Red)

Will light up when injection oil level is low. Check level and replenish as soon as possible.

▼ **CAUTION:** Do not run engine out of oil. Serious engine damage will occur.

○ **NOTE:** Whenever brake lever is actuated, oil injection level pilot lamp should light up. If not replace lamp.

G) Adjustable Steering Handle

- Remove steering pad.
- Loosen the four (4) retaining screws.
- Adjust the handle to the desired position.

◆ **WARNING:** Do not adjust too high as the brake lever may contact the windshield when turning.

- Lock the steering handle in place by tightening the four (4) retaining screws to 26 N•m (19 lbf•ft).
- Reinstall steering pad.

H) Emergency Cut-out Switch

A push pull type switch located on the right side of the handlebar. To stop the engine in an emergency, push the button to the lower off position and simultaneously apply the brakes. To start engine, button must be at the upper ON position.

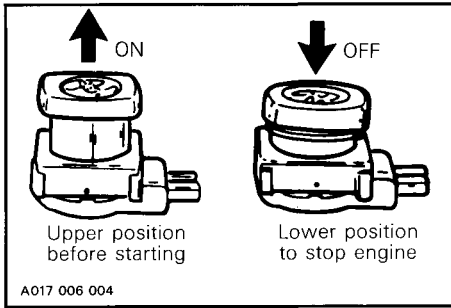

The driver of this vehicle should familiarize himself with the function of this device by using it several times on first outing. Thereby being mentally prepared for emergency situations requiring its use.

◆ **WARNING:** If the switch has been used in an emergency situation the source of malfunction should be determined and corrected before re-starting engine.

I) Throttle Lever

Located on the right side of handlebar. When compressed, it controls the engine speed and the engagement of the transmission. When released, engine speed returns automatically to idle.

J) Primer

A push-pull button located below handlebar. Pull and push button (2-3 times) to activate primer. The primer should always be used for cold engine starts. After engine is warm however, it is not necessary to use primer when starting.

K) Rewind Starter Handle

Auto rewind type located on right hand side of vehicle. To engage mechanism, pull handle.

L) Hood Latch

Pull down the latches to unlock the hood from its anchors.

○ **NOTE:** Always lift hood gently until stopped by restraining device.

◆ **WARNING:** It is dangerous to run an engine with the hood opened, unfastened or removed.

M) Fuel Tank Cap

Unscrew to fill up tank then fully tighten.

◆ **WARNING:** Never use an open flame to check fuel level.

N) Ignition/Light Switch

The lights are automatically ON when ever the engine is running.

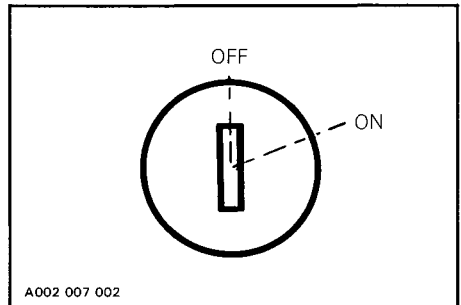

Key operated, two (2) position switch. To start the engine, first turn key to ON position. To stop the engine, turn the key to OFF position.

O) Fuel Level Indicator

Mounted on left side of fuel tank, it provides visual indication of fuel level in tank.

P) Tether Cut-out Switch

A pull switch located below the handlebar. Attach tether cord to wrist or other convenient location then snap tether cut-over receptacle before starting engine.

If emergency engine "shut off" is required completely pull cap from safety switch and engine power will be automatically shut "off".

○ **NOTE:** The cap must be installed on the safety switch at all times in order to operate the vehicle.

◆ **WARNING:** If the switch is used in an emergency situation the source of malfunction should be determined and corrected before restarting engine.

Q) Brake Level

Located on the left side of handlebar. When compressed, the brake is applied. When released, it automatically returns to its original position. Braking effect is proportional to the pressure applied on the lever and to the type of terrain and its snow coverage.

R) Headlamp Dimmer Switch

The dimmer switch, located on left side of handlebar, allows correct selection of headlamp beam. To obtain high or low beam simply flick switch.

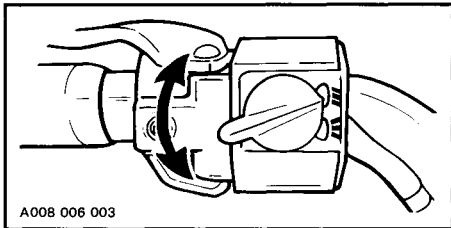

Tool Bag

To gain access, tilt hood. Ideal location for spare spark plugs, rope, first aid kit, flashlight, etc.

Spark Plug Holder

To keep spark plugs dry and prevent shocks that might affect the adjustment or break them, a holder is provided under hood, close to top of right shock absorber.

Fully tighten them into the holder.

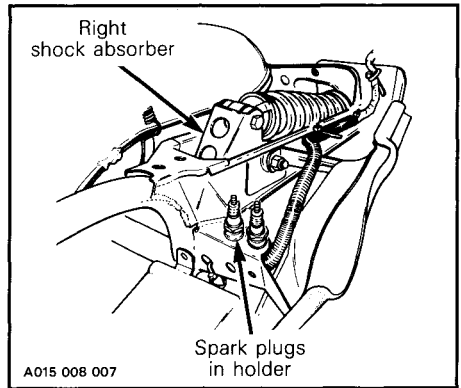

Fuse Holder

Tachometer

The tachometer is protected by a 0.1 ampere rated fuse. Fuse holder is located under the hood beside the tachometer. If it stops operating, check fuse condition and replace if necessary.

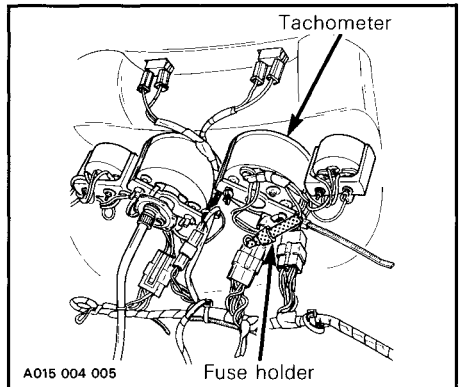

Spare Drive Belt Holder

A spare drive belt can be installed in drive belt holder clips on belt guard.

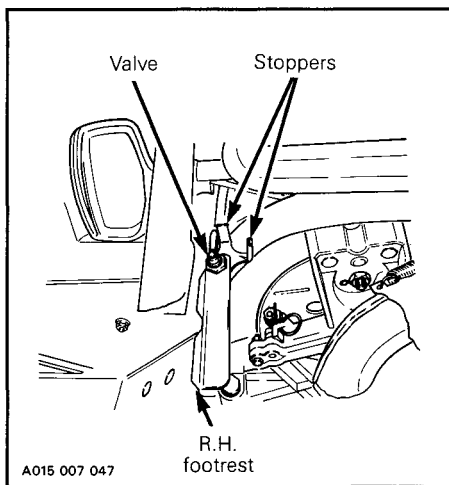
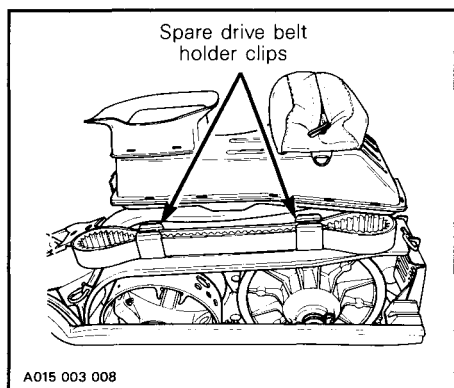

Fuel Shut-off Valve

It is recommended to close it when transporting or storing vehicle. The valve is under hood, on top of R.H. side footrest.

Two stoppers are provided on the fuel shut-off valve to prevent the lever from rotating due to vibrations.

These stoppers are set so that the inner tip of the lever slightly contacts the stoppers while in the **fully opened** or **fully closed** positions.

When opening or closing valve, always rotate lever so that it flips over the stopper and maintains its position.

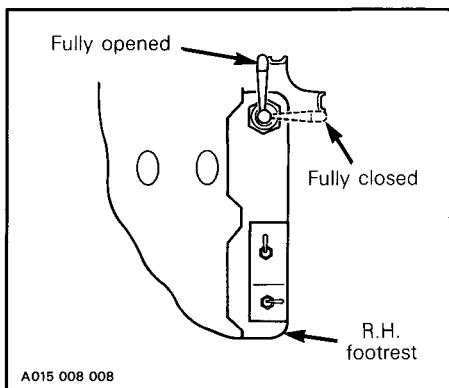

Fully open the valve in order to operate the vehicle.

▼ **CAUTION:** Always fully open the valve before riding. Never allow the valve lever to remain between stoppers.

Rear Bumper

The rear bumper can be installed in two (2) positions as desired by the driver. The low position can be used in deep snow to provide grip at a more convenient level.

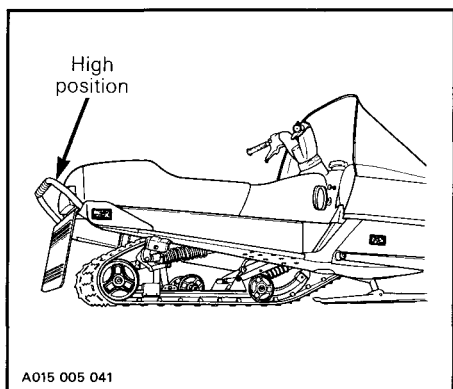
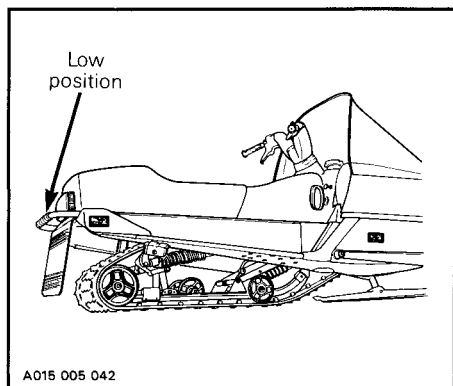

To install bumper in **lower** position, proceed as follows:

- Lift snow guard and block in that position.
- From inside tunnel, remove bumper retaining screws. Two per side.

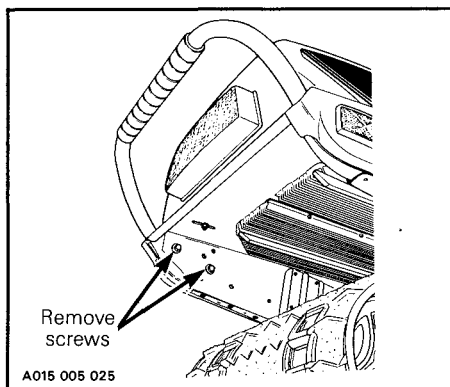

- Remove bumper.
- Reverse bumper position and insert in tunnel.
- When installing bumper in **lower** position, the retaining screws have to be relocated to different holes, as shown.

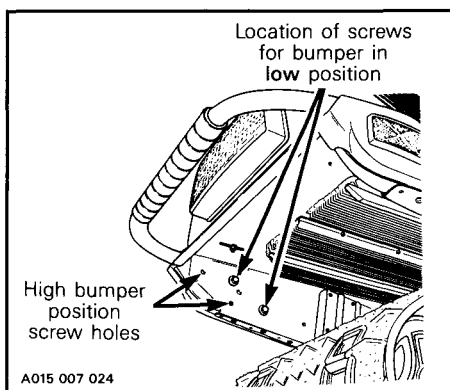

- Firmly tighten bumper screws.
- Lower snow guard.

NOTE: When installing bumper at **upper** position, bumper retaining screws have to be relocated to different holes, as shown.

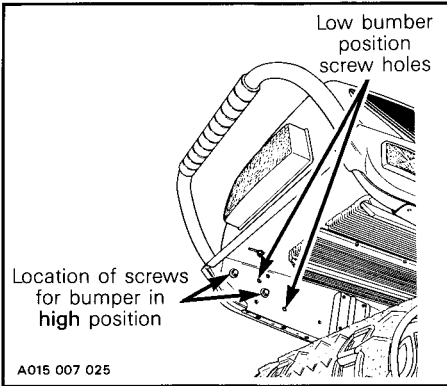

Accessories

A complete line of optional accessories is available for your snowmobile. Contact your authorized BOMBARDIER dealer for more information.

Front Grab Handle

Located at the front of the bottom pan, this grab handle must be used whenever front of vehicle is lifted.

▼ **CAUTION:** Do not use skis to pull or lift vehicle.

BREAK-IN PERIOD

Engine

With Bombardier-Rotax snowmobile engines, a break-in period is required before running the vehicle at full throttle. Engine manufacturer's recommendation is ten (10) to fifteen (15) operating hours. During this period, maximum throttle should not exceed $\frac{3}{4}$, however, brief full acceleration and speed variations contribute to a good break-in. Continued wide open throttle accelerations, prolonged cruising speeds, and lugging are detrimental during the break-in period.

 **NOTE:** To assure additional protection during the initial engine break-in, 500 ml (18 imp. oz) of BLIZZARD Oil (P/N 496 0135 00) or the same quantity of BOMBARDIER Injection Oil (P/N 496 0133 00) should be added to gas for the first full gas tank filling.

 **CAUTION:** Remove and clean spark plugs after engine break-in.

Belt

A new drive belt requires a break-in period of 25 km (15 miles).

10 - Hour Inspection

As with any precision piece of mechanical equipment, we suggest that after the first ten (10) hours of operation or thirty (30) days after the purchase, whichever comes first, your vehicle be checked by your authorized dealer. This inspection will give you the opportunity to discuss the unanswered questions you may have encountered during the first hours of operation.

The 10-hour inspection is at the expense of the vehicle owner.

10 - HOUR INSPECTION CHECK LIST	✓
Engine timing	
Spark plug condition: (remove and clean)	
Carburetor adjustments	
Oil injection pump adjustment	
Engine head nuts	
Drive pulley screw (torque)	
Engine mount screws	
Muffler attachment	
Chaincase oil level	
Drive chain tension	
Injection system oil level	
Rotary valve oil level	
Engine coolant level	
Brake operation and lining condition	
Ski alignment (runners condition), ski leg camber adjustment	
Steering arm, retorque to 25 N•m (18 lbf•ft)	
Handlebar bolts, retorque to 26 N•m (19 lbf•ft)	
Driven pulley preload	
Pulley alignment and drive belt condition	
Track condition, tension and alignment	
Suspension, torque rear axle screw to 48 N•m (35 lbf•ft)	
Lubrication (steering, suspension, drive axle, etc.)	
Electrical wiring	
Tighten all loose bolts, nuts and linkage	
Operation of lighting system (HI / LO beam, brake light, etc.), test operation of emergency cut-out switch and tether cut-out switch	

We recommend that you have your dealer sign this inspection.

Date of 10-hour inspection

Dealer signature

FUEL & OIL

Recommended Gasoline

Use regular unleaded gasoline, available from most service stations or gasohol containing less than 10 % ethanol.

◆ **WARNING:** Remove fuel tank cap slowly. Fuel may be under pressure and spray may cause fire and injuries. Gasoline is flammable and explosive under certain conditions. Always manipulate in a well ventilated area. Do not smoke or allow open flames or sparks in the vicinity.

▼ **CAUTION:** Never experiment with other fuels or fuel ratios. The use of gasoline containing methanol, or similar products including naphtha is not recommended. The use of unrecommended gasoline can result in vehicle performance deterioration and damage to critical parts in the fuel system and engine components.

◆ **WARNING:** Never top up the gas tank before placing the vehicle in a warm area. At certain temperatures, gasoline will expand and overflow. Always wipe off any gasoline spillage from the snowmobile.

Recommended Oil

Use BOMBARDIER Snowmobile Injection Oil (P/N 496 0133 00 - 1 liter) available from the authorized dealer. This type of oil will flow at temperatures as low as minus 40°C (-40°F).

It is a blend of specially selected base oils and additives which provides outstanding lubrication, engine cleanliness and minimum spark plug fouling.

If BOMBARDIER Snowmobile Injection Oil is unavailable, substitute with BLIZZARD Oil (P/N 496 0135 00).

▼ **CAUTION:** Never use outboard or straight mineral oils.

Oil Injection System

Always maintain a sufficient amount of BOMBARDIER Snowmobile Injection Oil in the injection oil tank.

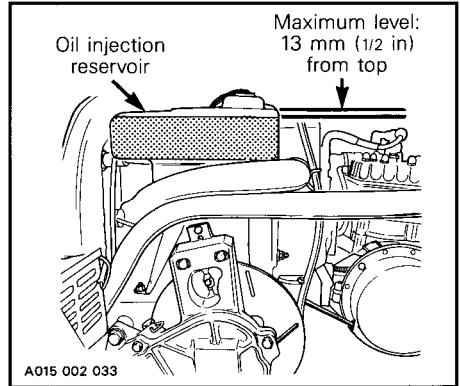

▼ **CAUTION:** Check level and refill every time you refuel. Do not overfill.

○ **NOTE:** For initial engine break-in, fill up fuel tank and add 500 ml (18 imp. oz) of BLIZZARD or same quantity of BOMBARDIER Injection Oil.

PRE-START CHECK

Check Points

- ACTIVATE THE THROTTLE CONTROL LEVER SEVERAL TIMES to check that it operates easily and smoothly. The throttle control lever must return to idle position when released.
- Check that the skis and the track are not frozen to the ground or snow surface and that steering operates freely.
- Activate the brake control lever and make sure the brake fully applies before the brake control lever touches the handlebar grip.
- Check coolant level. Liquid should be 60 mm (2 3/8 in) lower than top of radiator (engine cold).

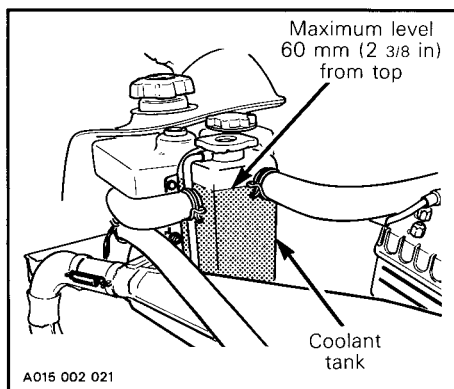

If additional coolant is necessary or if entire system has to be refilled, use a solution of three (3) parts of antifreeze for two (2) parts of water (60% antifreeze, 40% water). (See "Cooling System" in "Storage" section).

○ **NOTE:** Always use ethylene-glycol antifreeze containing corrosion inhibitors specifically recommended for aluminum engines.

◆ **WARNING:** Before removing the radiator pressure cap place a cloth over the cap and unscrew it to the first step to release the pressure. Never drain or refill the cooling system when engine is hot. Loss of fluid and severe burns could occur if this notice is disregarded.

- Check injection oil level.
- Check fuel level.
- Ensure fuel shut-off valve is in **fully opened position**.

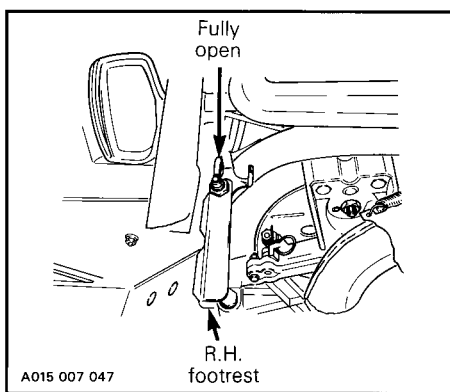

- Verify that the path ahead of the vehicle is clear of bystanders and obstacles.
- Clean and check operation of the head-light, taillight and brakelight.

◆ **WARNING:** Only start your snowmobile once all components are checked and functioning properly.

STARTING PROCEDURE

Test throttle control lever operation.

Check that the emergency cut-out switch is in the ON position.

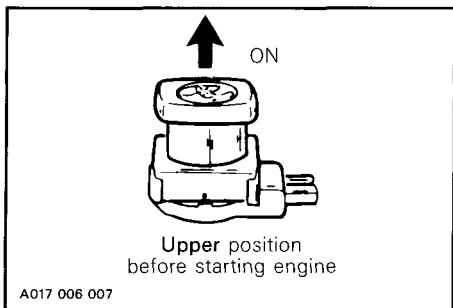

Ensure the tether cut-out cap is in position and that the cord is attached to your clothing.

Activate the primer two (2) or three (3) times.

○ **NOTE:** Primer is not necessary when the engine is warm.

▼ **CAUTION:** Use of ether and/or other types of fluid as a starting aid can cause damage to engine components and is not recommended.

Manual Starting

Insert the key in the ignition and turn to ON position.

Grasp manual starter handle firmly and pull slowly until a resistance is felt then pull vigorously. Slowly release the rewind starter handle.

◆ **WARNING:** Do not apply throttle while starting.

Before Riding

Check operation of the emergency cut-out switch and tether switch. Restart engine.

◆ **WARNING:** If engine does not shut-off when applying the emergency cut-out switch and/or when pulling the tether cut-out cap, stop the engine by turning OFF the ignition key. Do not operate the vehicle further, see an authorized dealer.

Allow the engine to warm before operating at full throttle.

Emergency Starting

Should the rewind starter rope fray and break, the engine can be started with the emergency starter rope supplied with the tool kit.

◆ **WARNING:** Do not wind starting rope around your hand. Hold rope by the handle only.

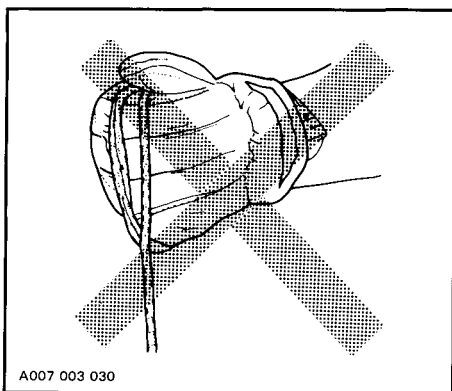

◆ **WARNING:** Do not start the vehicle by the drive pulley unless it is a true emergency situation. Have the vehicle repaired as soon as possible.

Attach emergency rope to any available handle and to the starter clip supplied in the tool box. Wind the rope tightly around drive pulley.

○ **NOTE:** The spark plug socket can be used as an emergency starter grip.

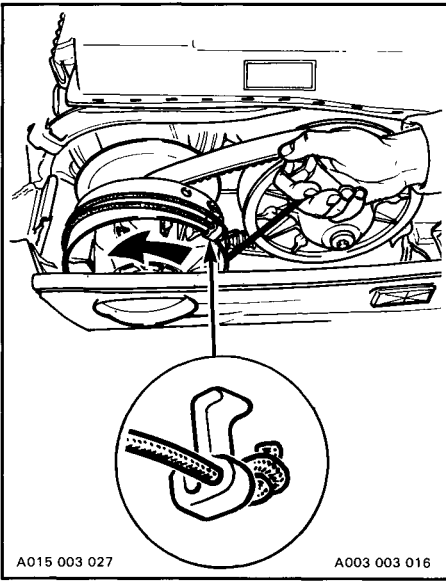
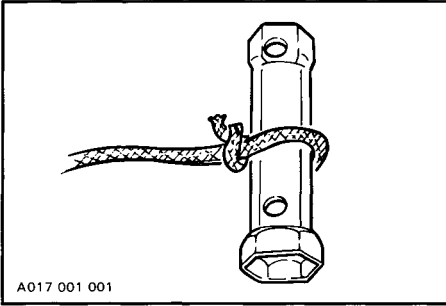

Start engine as per usual manual starting.

◆ **WARNING:** When starting the vehicle in an emergency situation, using drive pulley, do not reinstall the belt guard and return slowly to have vehicle repaired.

LUBRICATION

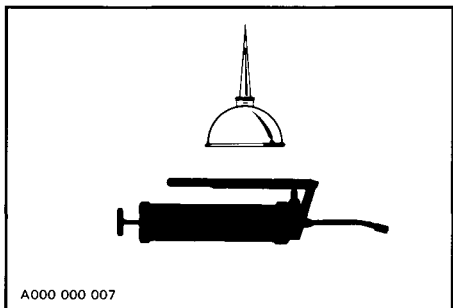

Frequency

Routine maintenance is necessary for all mechanized products and snowmobiles are no exception. A weekly vehicle inspection greatly contributes to the life span of the snowmobile.

It is recommended that the steering system and suspension be lubricated monthly or every forty (40) hours of operation. If the vehicle is operated in wet snow or in severe conditions these items should be lubricated more frequently.

Penetrating lubricant is recommended on ball joints and moving parts. Use either:

- chain lube from BARDAHL (BCS 362, dry)
- WD-40

Other grease fittings require low temperature grease (P/N 413 7061 00) using standard grease gun.

The following symbols will be used to show what type of lubricant should be used at required locations.

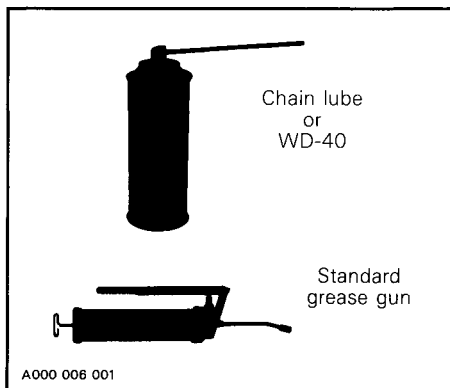

○ **NOTE:** When lubricating through grease fittings, slowly pump grease gun until grease appears at joints. Always use low temperature grease (P/N 413 7061 00).

◆ **WARNING:** Only perform such procedures as detailed in this manual. It is recommended that dealer assistance be periodically obtained on other components/systems not covered in this manual. Unless otherwise specified, engine should be turned OFF for all lubrication and maintenance procedures.

◆ **WARNING:** Do not lubricate throttle and/or brake cables and housings.

Steering and Front Suspension Mechanism

- Lubricate upper and lower control arms and tie rod ends.
- Grease ski legs, ski pivots and idler arm.

— Coat stabilizer sliders with grease and oil ball joints.

○ NOTE: There are thirty-three (33) lubrication points.

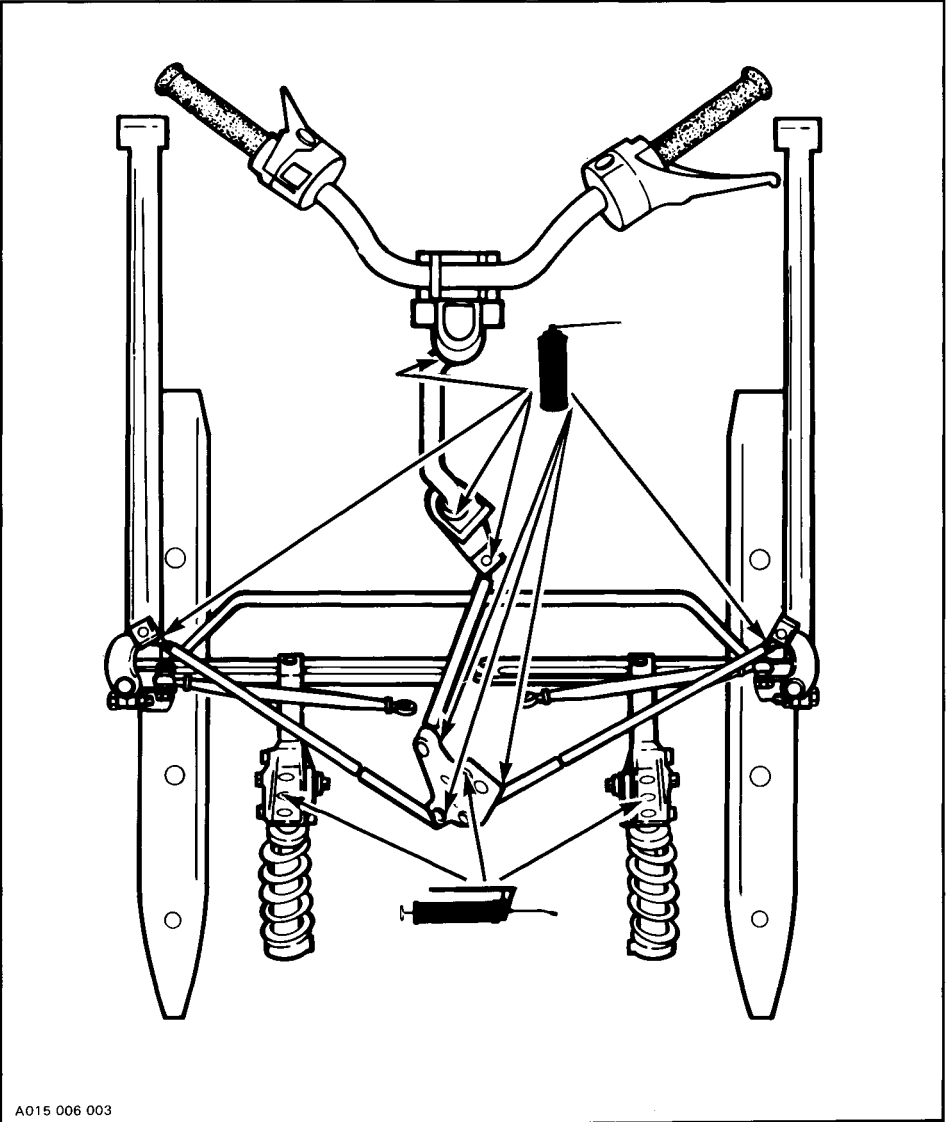

A015 006 003

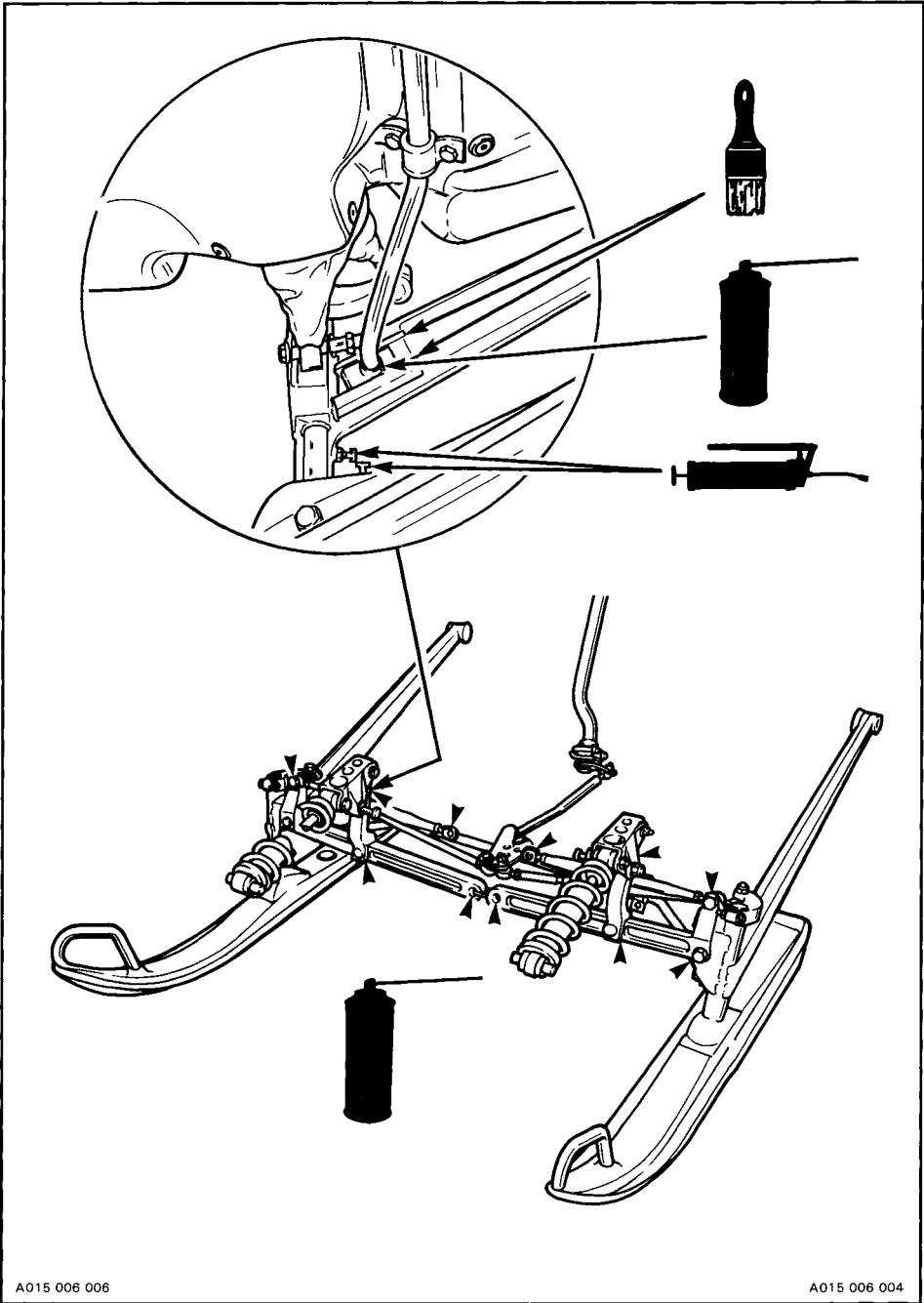

A015 006 006

A015 006 004

Drive Axle

Lubricate through grease fitting using low temperature grease only.

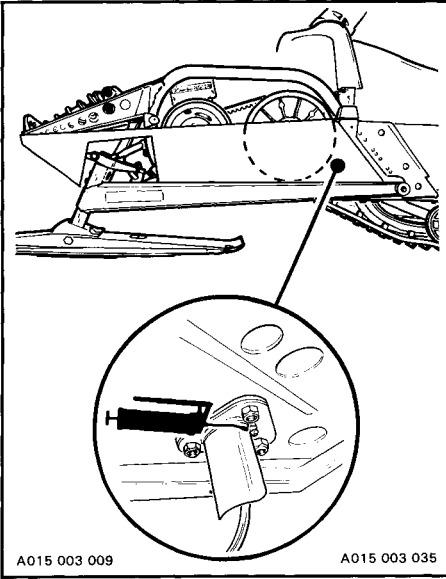

Countershaft (Brake Disc & Driven Pulley)

For proper operation, brake disc and driven pulley must slide freely on countershaft. Lubricate sparingly.

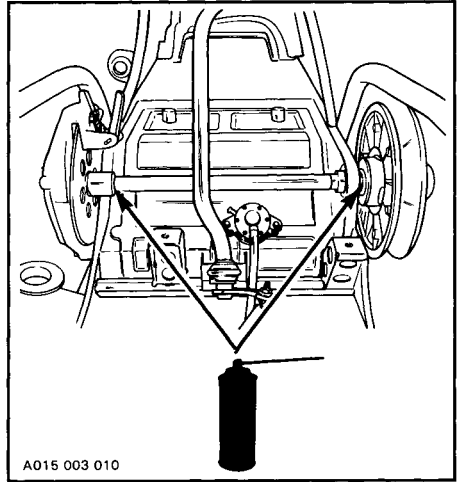

▼ **CAUTION:** Do not lubricate excessively as the lubricant could contact and soil brake pads and/or drive belt.

Slide Suspension

Lubricate track suspension through following grease fittings:

- front arm: upper and lower axle
- front swing arm: upper and lower axle
- front shackles
- rear arm: upper and lower axle
- rear shackle

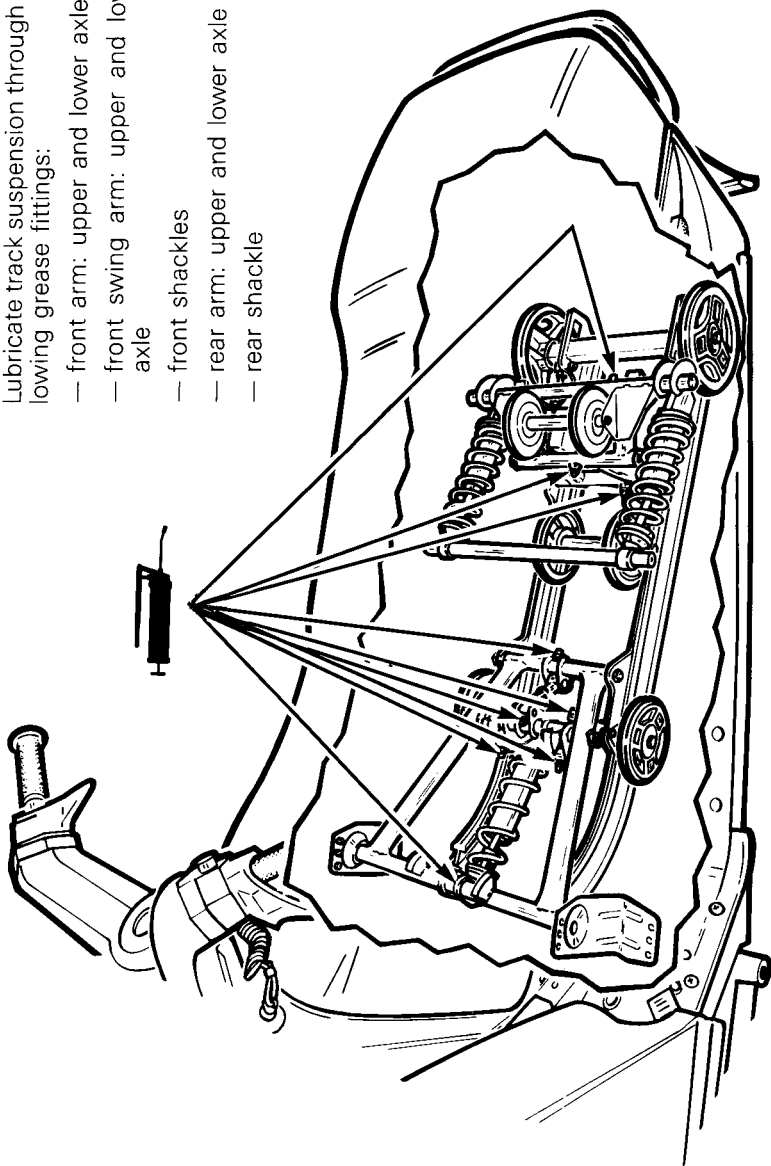

○ NOTE: There are nine (9) grease fittings on track suspension.

Chaincase Oil Level

Check the oil level by removing the oil filler cap. With dipstick unscrewed, oil level must be at lower mark. Refill as required using BOMBARDIER chaincase oil (P/N 413 8019 00 - 250 ml).

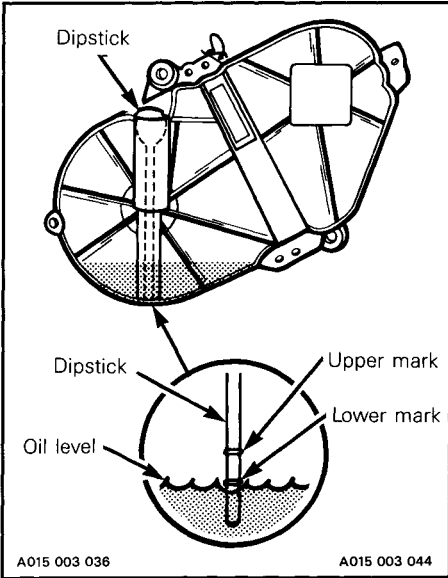

○ **NOTE:** The chaincase oil capacity is approximately 256 ml (9 imp. oz).

Oil Injection System

Always maintain a sufficient amount of BOMBARDIER Snowmobile Injection Oil in the injection oil tank.

▼ **CAUTION:** Check level and refill every time you refuel. Do not overfill.

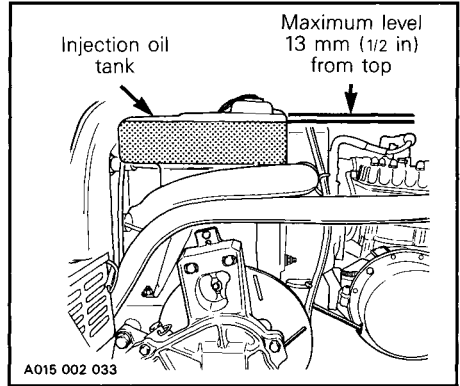

Rotary Valve System

The rotary valve system is lubricated with oil from the injection oil reservoir.

Always maintain a sufficient amount of BOMBARDIER Snowmobile Injection Oil in the injection oil tank.

▼ **CAUTION:** Check level and refill every time you refuel. Do not overfill.

MAINTENANCE

The following Maintenance Chart indicates regular servicing schedules to be performed by you or your authorized dealer. If these services are performed as suggested, your snowmobile will give many years of use.

WARNING: Only perform such procedures as detailed in this manual. It is recommended that dealer assistance be periodically obtained on other components/systems not covered in this manual. Unless otherwise specified, engine should be turned off for all lubrication and maintenance procedures.

SERVICE AND MAINTENANCE CHART	Weekly or every 240 km (150 mi)	Monthly or every 800 km (500 mi)	Once a year or every 3200 km (2000 mi)	Refer to page
Drive belt condition	■			31
Brake condition	■			31
Brake adjustment		■		31
Spark plugs		■		32
Suspension condition		■		32
Suspension adjustments		(as required)		32
Track condition		■		35
Track tension and alignment		(as required)		35
Drive pulley		■		36
Drive chain tension		■		37
Steering and front suspension mechanism		■		37
Ski and runner wear and condition	■			37
Steering and ski legs camber adjustment		■		37
Muffler attachment		■		37
Engine head nuts			■	37
Engine mount screws			■	38
Air filter cleaning		■		38
Carburetor adjustment (cable inspection)			■	38
Injection oil filter condition		■		39
Oil injection pump adjustment			■	39
Cooling system			■	40
Headlamp beam aiming			■	40
General inspection		■		40

NOTE: The 10-hour inspection is a very important part of proper service and maintenance.

Belt Guard Removal

◆ **WARNING:** Engine should be operated only when belt guard is properly secured.

1. Open hood.
2. Pull out both belt guard retaining pins.
3. Lift and remove the belt guard.

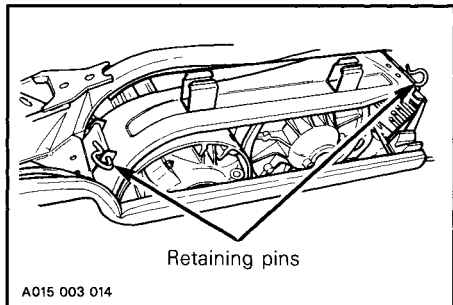

Drive Belt Removal and Installation

◆ **WARNING:** Never start or run engine without the drive belt installed. Running an unloaded engine is dangerous.

1. Open hood and remove belt guard.
2. Open the driven pulley by twisting and pushing the sliding half. Hold in fully open position.

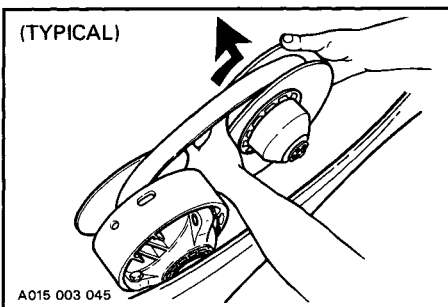

3. Slip the belt over the top edge of the fixed half, as shown.

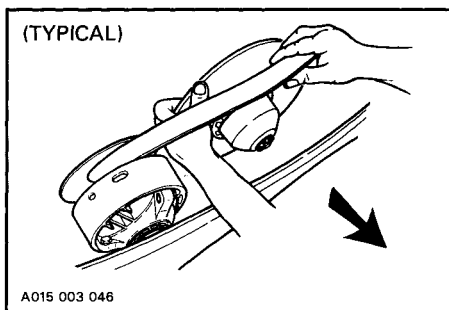

4. Slip the belt out from the drive pulley and remove from the vehicle.

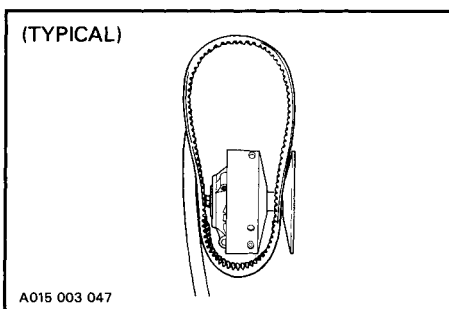

To install the drive belt, reverse the procedure, however pay attention to the following:

Maximum drive belt life span is achieved when belt runs in the same direction. Always install drive belt so printed information can be read when facing pulleys.

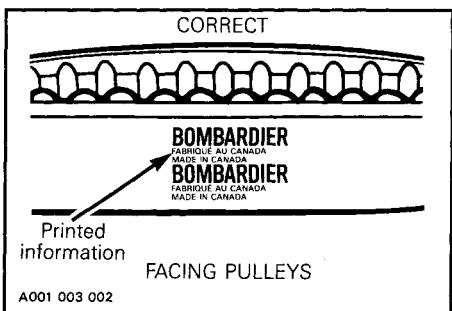

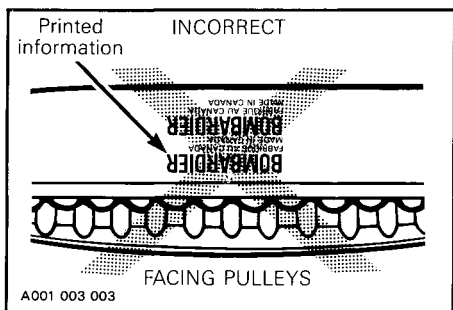

CAUTION: Do not force or use tools to pry the belt into place, this could cut or break the cords in the belt.

Drive Belt Condition

Inspect belt for cracks, fraying or abnormal wear (uneven wear, wear on one side, missing cogs, cracked fabric). If abnormal wear is noted, probable cause could be pulley misalignment, excessive R.P.M. with frozen track, fast starts without warm-up period, burred sheave, oil on belt or distorted belt. Contact your authorized dealer.

Check drive belt width, replace if less than 31.9 mm (1 1/4 in).

New Drive Belt

When installing a new drive belt, break-in period of 25 km (15 miles) is strongly recommended.

Brake Condition

The brake mechanism on your snowmobile is an essential safety device. Keep this mechanism in proper working condition. Above all, do not operate the snowmobile without an effective brake system.

WARNING: Brake pads must be replaced when fixed pad projects 1 mm (1/32 in) or less from caliper. Replacement must be performed by an authorized dealer.

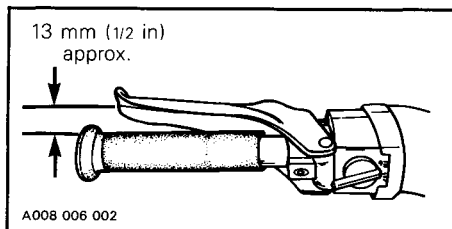
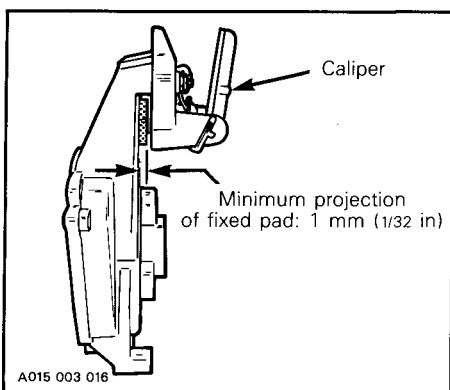

Brake Adjustment

The brake mechanism is a self-adjusting type. If a quicker brake response is desired, strongly squeeze the brake lever several times, this will actuate the self adjusting mechanism.

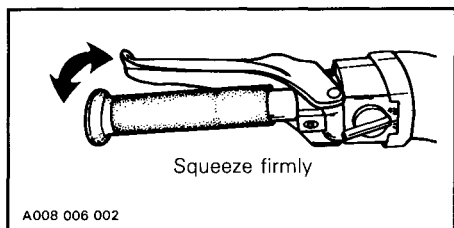

After the adjustment, brake should apply fully when lever is approximately 13 mm (1/2 in) from handlebar grip. If not, do not tamper with the brake, contact your servicing dealer.

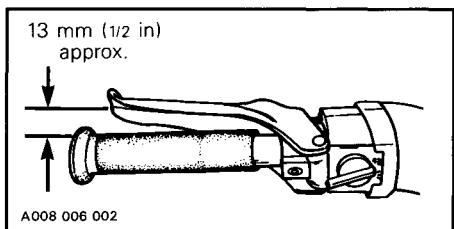

Spark Plugs

Disconnect the spark plug wires and remove the spark plugs.

Check the condition of the plugs.

- A brownish tip reflects ideal conditions. (Carburetor adjustments, spark plug heat range, etc., are correct).
- A black insulator tip indicates fouling caused by: carburetor idle speed mixture and/or high speed mixture too rich, incorrect fuel mixture ratio, wrong type of spark plug (heat range), or excessive idling.
- A light grey insulator tip indicates a lean mixture caused by: carburetor high speed mixture adjusted too lean, wrong spark plug heat range, incorrect fuel mixture ratio, or a leaking seal or gasket.

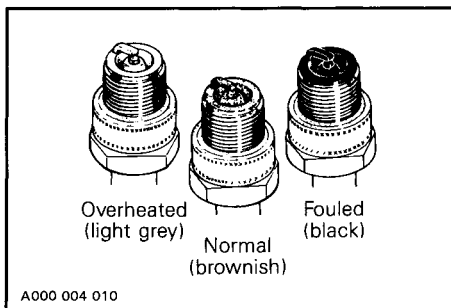

CAUTION: If spark plug condition is not ideal, contact your authorized dealer.

Check spark plug gap using a wire feeler gauge, adjust to 0.4 mm (.016 in). Reinstall plugs and connect wires.

Suspension Condition

Check all front suspension components for excessive play or wear including ball joints, control arms and links etc.

Visually inspect all rear suspension components including slider shoes, springs, wheels, etc.

NOTE: During normal driving, snow will act as a lubricant and coolant for the slider shoes. Extensive riding on ice or sanded snow will create excessive heat build-up and cause premature slider shoe wear.

Suspension Adjustments

The rear suspension has three adjustments:

- The front shock spring for surface condition.
- The rear shock spring (twin shocks) for driver's weight.
- Limiter screw to control weight transfer during acceleration.

Shock Absorber Spring Adjustment

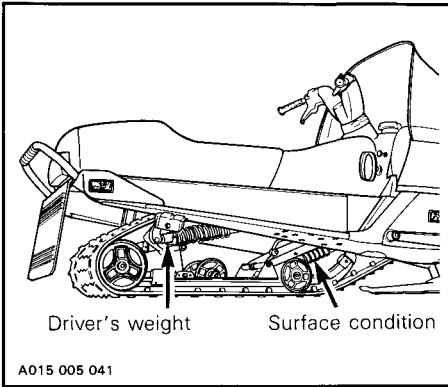

Each shock absorber has a five (5) position cam located at the bottom of the shock. Spring preload may be increased or decreased by turning the cam.

To adjust, use the adjustment key supplied. Spray WD-40 between spring and spring collar.

CAUTION: There must be two (2) thrust washers between spring and spring collar. If missing, do not attempt to adjust. See an authorized dealer for installation.

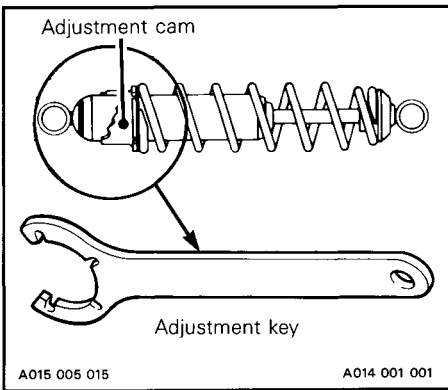

Front Spring

NOTE: The front shock absorber of the rear suspension should be removed to adjust spring collar.

When the front spring cam is at the lowest elevation more weight is distributed on the skis.

At the highest position the weight is transferred from the skis to the track.

Rear Spring

Driver's weight kg (lb)		Cam position
from	to	
—	64 (140)	1
64 (140)	73 (160)	2
73 (160)	82 (180)	3
82 (180)	—	4 — 5

Fit the key on the shock spring collar and turn clockwise to stiffen or counterclockwise to soften.

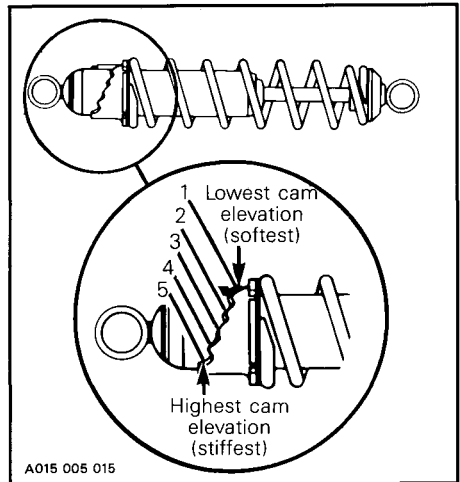

Choice of cam positions depends on operator's weight, riding speed and field conditions.

Cam position	1	2	3	4	5
Operator's weight	Light \longrightarrow Heavy				
Riding speed	Low \longrightarrow High				
Field condition	Flat \longrightarrow Bumpy				

Slight suspension bottoming occurring under the worst riding conditions indicates a good choice of preload adjustment (cam position).

Optional different rate springs are available for your convenience. Ask an authorized dealer for more information.

Limiters Screw

The function of the suspension limiter screw is to control the transfer of vehicle weight **during acceleration**. The closer the nut is to the cotter pin, the more the weight will be transferred to the track to provide better traction. The farther the nut is from the cotter pin the less weight will be transferred to the track, maintaining a more positive steering. Limiter screw allows weight transfer adjustment according to driver's requirement, field and/or snow conditions.

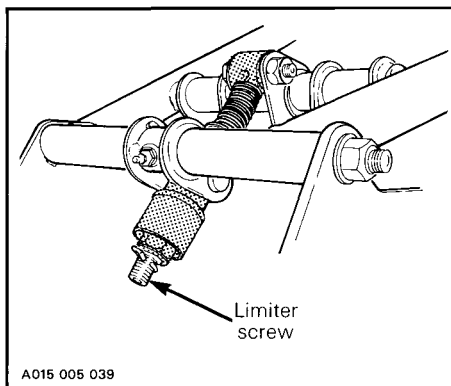

The following table is a general guideline only:

Snow condition	Nut/cotter pin position
Hill climbing	Close
Hard surface	Far

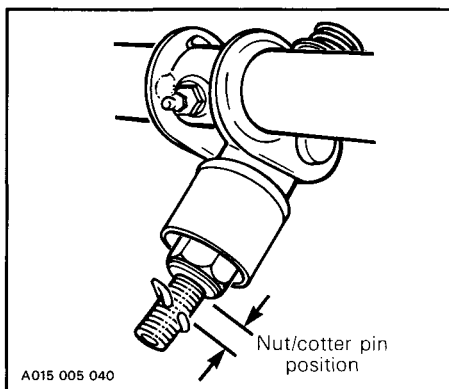

In Deep Snow

When operating the vehicle in deep snow, it may be necessary to vary the position of front spring adjustment cam, limiter screw and/or riding position, to change the angle at which the track rides on the snow. Operator's familiarity with the various adjustments as well as snow conditions will dictate the most efficient combination.

Track Condition

Lift the rear of the vehicle and support it off the ground. With the engine **off**, rotate the track by hand, and inspect condition. If worn or cut, or if track fibers are exposed, or if missing or defective inserts or guides are noted; contact an authorized dealer.

◆ **WARNING:** Do not operate a snowmobile with a cut, torn or damaged track.

Track Tension and Alignment

Tension:

○ **NOTE:** Ride the vehicle in snow about fifteen (15) to twenty (20) minutes prior to adjusting track tension.

Lift rear of vehicle and support it with a mechanical stand. Allow the suspension to extend normally and check gap half-way along slider shoe. The gap should be 30 mm (1 3/16 in) between the slider shoe and the bottom inside of the track when applying a downward pull of 7.3 kg (16 lb). If the track tension is too loose, track will have a tendency to thump.

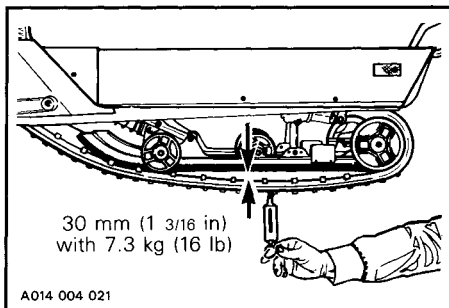

▼ **CAUTION:** Too much tension will result in power loss and excessive stresses on suspension components.

If adjustment is necessary, loosen the rear idler wheel retaining screws and the adjuster bolt lock nuts, then loosen or tighten the adjuster screws located on the inner side of the rear idler wheels. If correct tension is unattainable, contact an authorized dealer.

○ **NOTE:** Torque retaining screw to 48 N•m (35 lbf•ft) after adjustment.

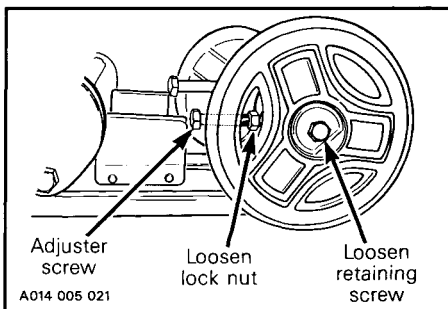

○ **NOTE:** Track tension and alignment are inter-related. Do not adjust one without the other.

Alignment

Start the engine and accelerate just so that track turns **slowly**. Check that the track is well centered; equal distance on both sides between edges of track guides and slider shoes.

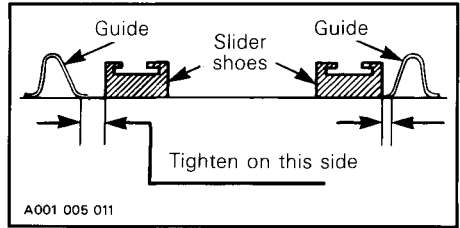
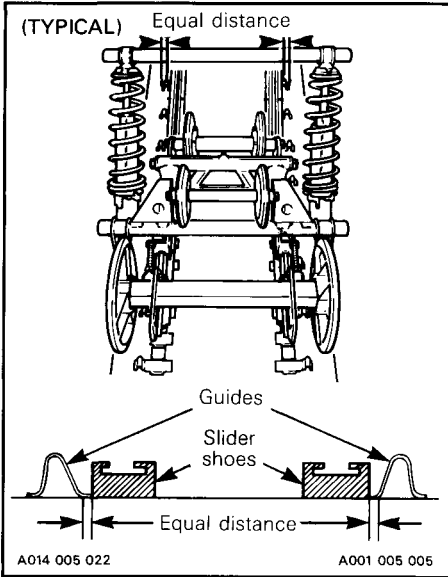

Tighten adjuster screw lock nuts and idler wheel retaining screws.

○ NOTE: Torque retaining screw to 48 N•m (35 lbf•ft) after adjustment.

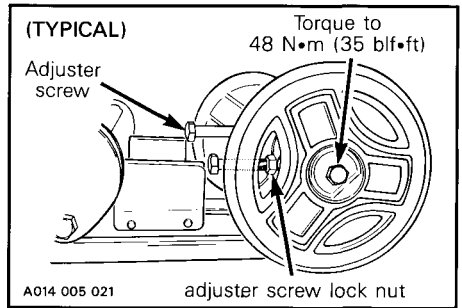

Restart engine, rotate track **slowly** and recheck alignment.

Drive Pulley

This vehicle is equipped with the TRA drive pulley (Total Range Adjustable).

The clutch is factory adjuster to provide the best performance under most riding conditions. However certain conditions, such as deep snow, high altitude, pulling a load, etc., may require a different adjustment. Contact the authorized dealer for adjustment.

◆ **WARNING:** The drive pulley must be inspected and cleaned by an authorized dealer at least annually.

Drive Chain Tensioner

Run vehicle forward so that true free-play can be taken. To adjust, remove adjusting screw hair pin. Fully tighten adjusting screw **by hand** then back off only far enough for hair pin to engage locking hole and install hair pin.

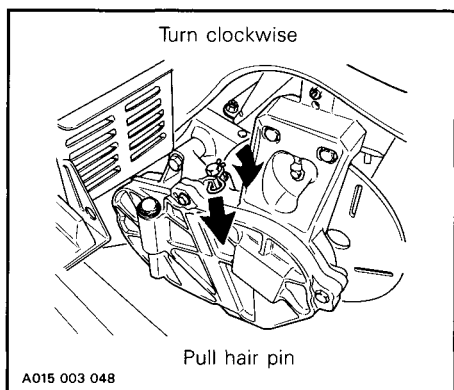

This adjustment should provide 3-5 mm (1/8 - 13/64 in) free-play when measured at the outer circumference of the brake disc.

▼ **CAUTION:** Free-play must not exceed 5 mm (13/64 in), readjust if necessary.

◆ **WARNING:** If the specified free-play is not reached with the tensioner screw fully tightened, consult an authorized dealer.

Steering and Front Suspension Mechanism

Inspect steering and front suspension mechanism for tightness of components (steering arms, for control arms and links, tie rods, ball joints, ski coupler bolts etc.). If necessary replace or retighten.

Check the condition of the skis and the ski runners. Replace if worn.

◆ **WARNING:** Excessively worn skis and/or ski runners will hinder proper vehicle control.

Steering and Ski Leg Camber Adjustment

There are accurate front suspension geometry adjustments to perform on this vehicle and they should be done only by an authorized dealer.

Muffler Attachment

The exhaust system parts are vital toward efficient engine function. Check all muffler ball joints and attachments. Replace springs or tighten if necessary.

▼ **CAUTION:** Do not operate vehicle with muffler disconnected, serious engine damage will occur.

Engine Head Nuts

With ENGINE COLD, check that the engine head nuts are tight and torqued to 20 N•m (15 lbf•ft).

Follow tightening sequence shown:

467 Engine Type

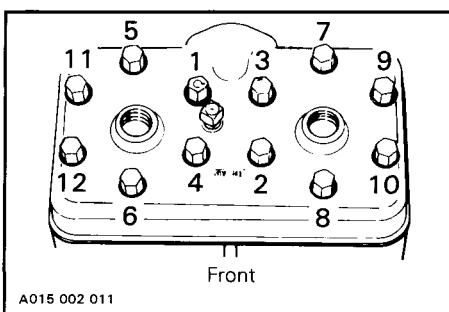

536 Engine Type

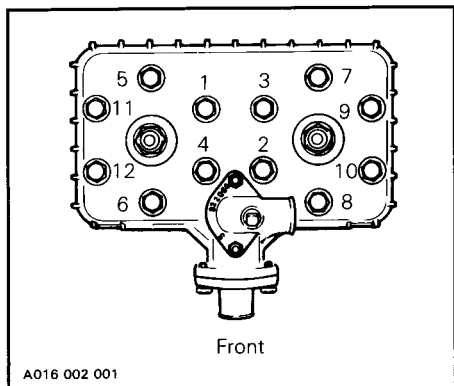

IMPORTANT: Engine head nut torque should be checked after the first five (5) hours of operation.

Engine Mount Screws

Check engine mount screws for tightness. Retighten if necessary to 25 N•m (18 lbf•ft).

Air Filter

Leaving the vehicle uncovered during a snowfall or riding in deep powder snow may block air filter.

Lift hood and remove air filter from air intake silencer.

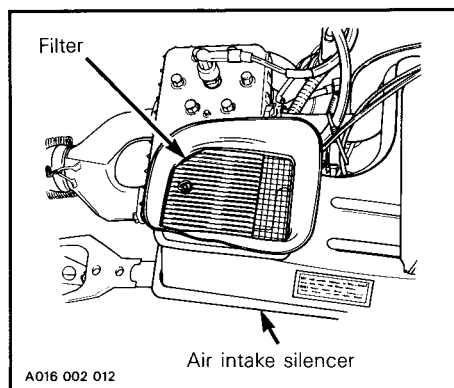

To clean the filter, shake the snow out of it then, dry it out.

Check that the air box is clean and dry and reinstall the filter.

CAUTION: These vehicles have been calibrated with the filter installed. Operating the vehicle without it will cause damage to the engine.

Reinstall properly.

Carburetor Adjustment

CAUTION: Never operate your snowmobile with the air intake silencer disconnected. Serious engine damage will occur if this notice is disregarded.

CAUTION: Make sure both carburetors start to operate simultaneously.

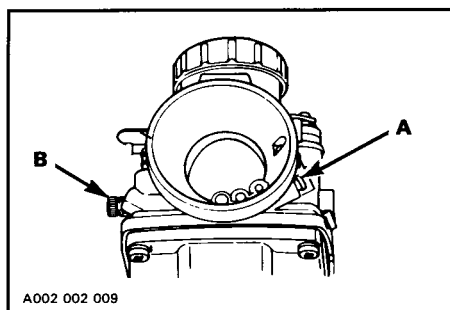

A) Air Screw Adjustment

Slowly close the air screw (until a slight seating resistance is felt) then unscrew number of turns shown below:

467 engine type: 1 1/2 turns
536 engine type: 1 1/3 turns

B) Idle Speed Adjustment

Turn **idle speed** screw clockwise until it contacts the throttle slide then continue turning two (2) additional turns. This will provide a preliminary idle speed setting. Start engine and allow it to warm up. Adjust idle speed to 1800-2000 R.P.M. by turning the idle speed screw clockwise or counterclockwise.

▼ **CAUTION:** Do not attempt to set the idle speed by using the air screw. Severe engine damage can occur. If idle speed is unattainable contact your authorized dealer.

High Altitude Kit

Snowmobiles used in high altitude areas (1200 m (4000 ft) and up) are subjected to a loss of power of about 3% per 300 m (1000 ft) of elevation. The carburetor and power train must be recalibrated to meet those particular requirements. Ask your authorized dealer for more information on high altitude kit availability.

Oil Injection System

Injection Oil Filter Condition

Inspect oil filter at least once a month. Insure that filter is not obstructed by foreign particles; if so, see an authorized dealer.

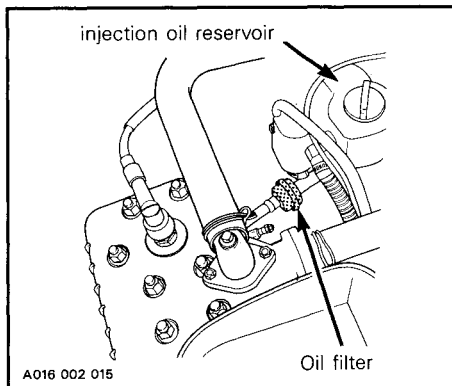

▼ **CAUTION:** An obstructed injection oil filter will cause oil starvation resulting in serious engine damage.

○ **NOTE:** After a storage period, it is important that your dealer replace the injection oil filter and that he verifies the oil flow of the injection pump.

Injection Pump Adjustment

Proper oil injection pump adjustment is critical, any delay in the opening of the pump can result in serious engine damage.

▼ **CAUTION:** The carburetor must be adjusted before adjusting the oil injection pump. Make sure idle speed is 1800-2000 R.P.M.

To check adjustment: eliminate the throttle cable free-play by pressing the throttle lever until a slight resistance is felt then hold in place. The marks on the pump casting and lever must align perfectly. If not, contact an authorized dealer.

○ **NOTE:** Injection pump should be adjusted by your authorized dealer only.

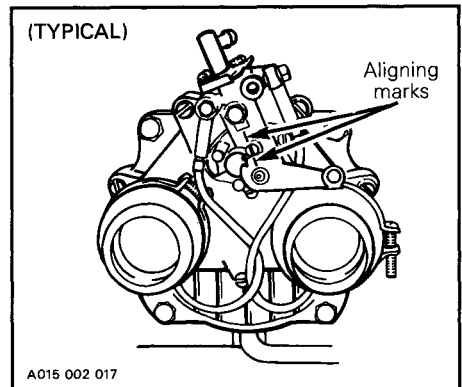

Cooling System

Check condition of hoses and tightness of clamps. Using a hydrometer check that antifreeze solution is adequate for the temperatures at which the vehicle will be operated.

○ **NOTE:** If coolant temperature rises above recommended range of 50 to 100°C (120 to 212°F), hose off grime from the heat exchanger (underneath the frame above the track).

Headlamp Beam Aiming

To adjust, remove the four adjusting screw (4) caps and turn upper or lower adjusting screws to obtain desired beam position.

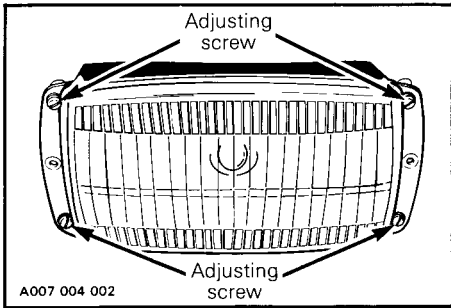

Replace adjusting screw caps after adjustment.

Bulb Replacement

If the headlamp bulb is burnt, open hood and unplug the connector from the headlamp. Remove the rubber boot and unfasten bulb retainer clips. Detach the bulb and replace.

Installation is the reverse of removal procedure.

▼ **CAUTION:** Never touch glass portion of an halogen bulb with bare fingers, it shortens it's operating life. If by mistake glass is touched clean it with a glass cleaner that will not leave a film on the bulb.

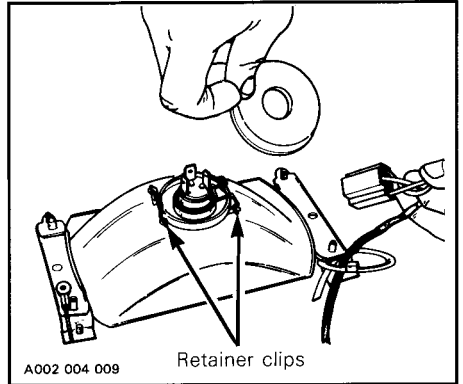

If taillight bulb is burnt, unfasten the two (2) screws holding the lens and remove. Replace bulb and install lens. Do not over tighten lens retaining screws.

◆ **WARNING:** Always check light operation after bulb replacement.

General Inspection

Check the electrical wiring and components, retighten loose connections. Check for stripped wires or damaged insulation. Thoroughly inspect the vehicle and tighten loose bolts, nuts and linkage. Inspect skis and ski runners for wear.

STORAGE

It is during summer, or when a vehicle is not in use for any length of time that proper storage is a necessity. Storage of the snowmobile during long periods of inactivity consists of checking and replacing missing, broken or worn parts: Proper lubrication and treatment to insure that parts do not become rusted; cleaning items such as carburetor, to prevent gum and varnish formation within the carburetor; and in general, preparing the vehicle so that when the time comes to use the snowmobile again it will be in top condition.

◆ **WARNING:** Only perform such procedures as detailed in this manual. It is recommended that dealer assistance be periodically obtained on other components/systems not covered in this manual. Unless otherwise specified, engine should be turned OFF for all lubrication and maintenance procedures.

Track

Inspect the track for wear, cuts, missing track guides and broken rods. Make any necessary replacement.

◆ **WARNING:** Do not operate a snowmobile with a cut, torn or damaged track.

Lift rear of vehicle until track is clear of the ground and support with a brace or trestle. The snowmobile should be stored in such a way that the track does not stay in contact with cement floor or bare ground.

○ **NOTE:** Track should be rotated periodically, (every 40 days). Do not release track tension.

▼ **CAUTION:** To prevent track damage, temperature in the storage area must not exceed 38°C (100°F).

Suspension

Remove any dirt or rust. Grease at all recommended grease points. Wipe off surplus. Replace worn slider shoes.

Skis and runners

Wash or brush all dirt or rust accumulation from the skis and springs. Grease at all grease fittings.

◆ **WARNING:** Check the condition of the skis and ski runners. Replace if worn more than half.

Controls

Lubricate the steering mechanism. Inspect all components for tightness, (spring coupler bolts, steering arm locking bolts, tie rods, ball joints, etc.). Tighten if necessary. Oil all moving joints of the brake mechanism.

◆ **WARNING:** Do not lubricate the throttle and/or brake cables and housings. Avoid getting oil on the brake pads.

Coat all electrical connections and switches with a greaseless metal protector. If unavailable, use petroleum jelly.

Chaincase

Drain the chaincase and refill to proper level, using fresh chaincase oil. (P/N 413 8019 00 - 250 ml). To drain, remove the chaincase cover.

○ **NOTE:** Chaincase oil capacity is about 256 ml (9 fl. oz).

Countershaft (Brake Disc & Driven Pulley)

For proper operation, brake disc and driven pulley must slide freely on countershaft. Lubricate sparingly.

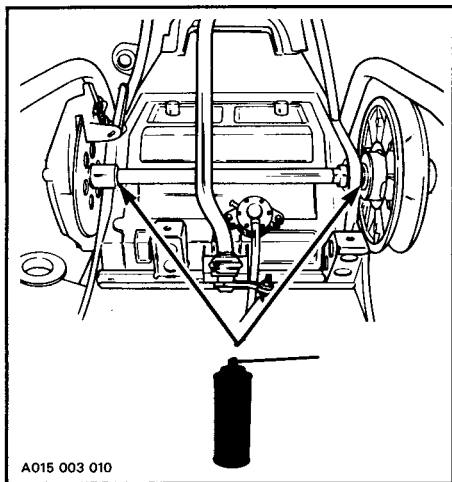

A015 003 010

▼ **CAUTION:** Do not lubricate excessively as lubricant could contact and soil brake pads and/or drive belt.

Cooling System

The engine cooling system should be drained and refilled with a new coolant mixture before each storage period.

◆ **WARNING:** Never drain or refill the cooling system when engine is hot.

To drain the cooling system: siphon the coolant mixture from the coolant tank using a primer pump, a length of plastic hose and steel tubing inserted as deep as possible into the lower hose of the tank.

◆ **WARNING:** Use PRIMER PUMP to siphon the coolant mixture. Do not siphon with your mouth. Coolant mixture is poison and can be fatal if swallowed.

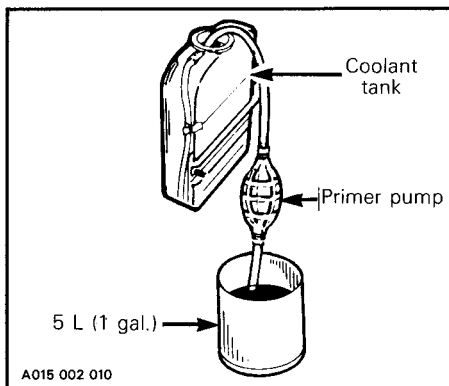

A015 002 010

When the coolant level is low enough, remove the engine bleed screw and lift the rear of vehicle to drain the heat exchangers.

▼ **CAUTION:** To prevent rust formation in the cooling system, always replenish the system with the recommended solution (60% antifreeze 40% water). Pure antifreeze, without water, freezes. Always use ethylene-glycol antifreeze containing corrosion inhibitors specifically recommended for aluminum engines.

To refill the cooling system:

— Lower rear of vehicle to ground.

467 Engine Type

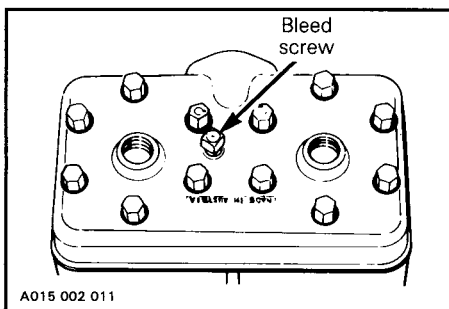

A015 002 011

- Refill tank slowly until coolant overfills at bleed hole.
- Reinstall bleed screw.

536 Engine Type

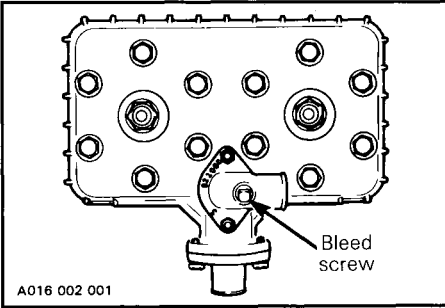

Continue to pour the coolant in the tank until level reaches 60 mm (2 3/8 in) below top of radiator (engine cold).

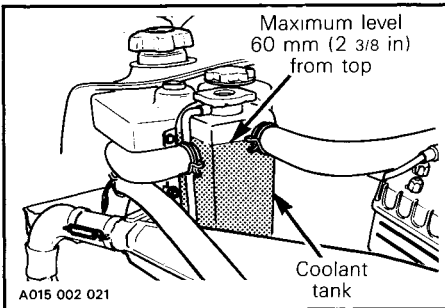

With the coolant tank cap still removed start the engine and let it warm up to reach its operating temperature and open thermostat. Run a few minutes more.

Stop engine and check coolant freezing point with a suitable tester. Freezing point must be low enough for the temperatures at which the vehicle will be operated.

Check level and add coolant if required. Install coolant tank cap.

WARNING: Before removing the cap place a cloth over the coolant tank and release the cap to the first step to release the pressure. Loss of fluid and severe burns could occur if this notice is disregarded.

Engine Lubrication

Engine internal parts must be lubricated to protect them from possible rust formation during the storage period.

To perform the storage procedures proceed as follows:

1. Lift the rear of the vehicle and support it off the ground.

WARNING: Ensure the track is free of all particles which could be thrown out while it is rotating. Keep hands, tools, feet and clothing clear of track. Ensure no one is standing in close proximity to the vehicle.

2. Start the engine and allow it to run at idle speed until the engine reaches its operating temperature.
3. Stop the engine.
4. To prevent gasoline from draining, primer button should be pushed all the way in.
5. Disconnect the outlet primer hose from the primer valve.

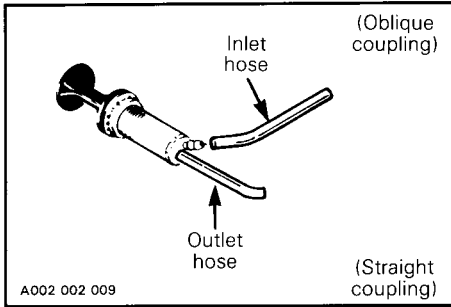

6. Insert storage oil (P/N 496 0141 00) nozzle into primer outlet hose.
7. Restart engine and run at idle speed.
8. Inject storage oil until the engine stalls or until a sufficient quantity of oil has entered the engine (approximately half a can).
9. With the engine stopped, remove the spark plug and pour approximately 150 ml (5 imp. oz) of Ski-Doo storage oil (P/N 496 0141 00) into each cylinder.
10. Slowly crank the engine 2 or 3 revolutions to distribute oil.
11. Reinstall the spark plugs and the outlet primer hose.

CAUTION: Do not run engine during storage period.

WARNING: This procedure must only be performed in a well ventilated area.

Drive Pulley

Inspection and cleaning must be performed by an authorized dealer at the end of each season.

Driven Pulley

Remove pulley guard and slip off drive belt. Open the driven pulley (push and twist sliding half).

Thoroughly clean the driven pulley shaft.

Apply a light film of low-temperature grease on the shaft. Wipe off surplus.

NOTE: Activate the sliding half several times to distribute lubricant over full length of shaft. Be careful that lubricant does not get on inner face of pulleys.

Fuel Tank and Carburetors

Remove the cap and using a siphon, drain gasoline from tank.

WARNING: Gasoline is flammable and explosive under certain conditions. Always manipulate in a well ventilated area. Do not smoke or allow open flames or sparks in the vicinity.

Carburetors must be dried out completely to prevent gum formation during the storage period.

Once the fuel tank is emptied, remove the float chamber drain plug on each carburetor and drain carburetor.

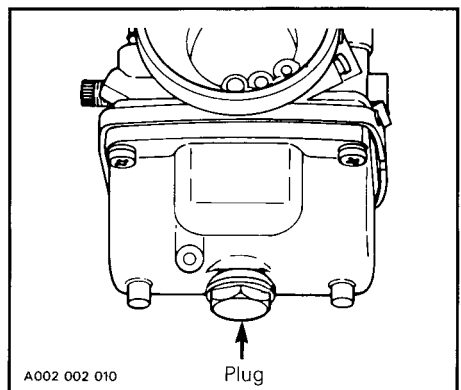

Reinstall plug.

Check all fuel lines, replace if necessary.

Chassis

Clean the vehicle thoroughly, removing all dirt and grease accumulation.

▼ **CAUTION:** Plastic alloy components such as fuel tank, windshield, controls, etc., can be cleaned using mild detergents or isopropyl alcohol and a soft clean cloth. Never clean plastic parts with strong detergent, degreasing agent, paint thinner, acetone, etc. Never clean RIM Metton hood with cleaners or products containing chlorine. Do not apply isopropyl alcohol directly on decals.

Inspect the hood and repair any damage. Clean the frame. For the unpainted aluminum portion use only "Aluminum cleaner" and follow instructions on the container.

Touch up all metal spots where paint has been scratched off. Spray all metal parts with metal protector. Wax the hood and the painted portion of the frame for better protection.

○ **NOTE:** Apply wax on glossy finish only. Protect the vehicle with a cover to prevent dust accumulation during storage.

▼ **CAUTION:** If snowmobile has to be stored outside it is necessary to cover it with an opaque tarpaulin. This will prevent sun rays and grime from affecting plastic components and vehicle finish.

General Inspection

Check the electrical wiring and components, retighten loose connections. Check for stripped wires or damaged insulation.

Thoroughly inspect the vehicle and tighten loose bolts, nuts and linkage.

○ **NOTE:** Leave drive belt off the pulleys for entire storage period.

PRE-SEASON PREPARATION

To simplify the pre-season preparation we have drawn up a chart which indicates service points to be performed by you and your authorized dealer. If these services are performed as suggested, your vehicle will give you many hours of fun.

IMPORTANT: Observe all warnings and cautions mentioned throughout this manual which are pertinent to the item being checked. When component condition seems less than satisfactory, replace with genuine BOMBARDIER parts or suitable equivalents.

PRE-SEASON PREPARATION CHART	TO BE PERFORMED BY DEALER	●
	TO BE PERFORMED BY OWNER	○
Change spark plugs*		○
Check chaincase oil level		○
Check drive chain tension		○
Check rotary valve oil level		○
Replace fuel filter (filter is located inside fuel tank)		○
Clean air filter		○
Refill gas tank		○
Check track condition, tension and alignment		○
Check and lubricate suspension		○
Inspect drive belt and install		○
Check throttle cable for free operation		○
Check steering, ski legs camber adjustments and ski runners condition		●
Check electrical wiring		○
Inspect condition of starting rope		○
Check tightness of all bolts, nuts and links		○
Check coolant condition and level		●
Inspect seals for possible cuts or leaks		○
Inspect brake condition and operation		○
Replace injection oil filter		●
Refill injection oil tank		●
Adjust oil injection pump		●
Set engine timing		●
Check pulleys, verify components and clean		●
Adjust carburetors		●

○ ***NOTE:** Before installing new spark plugs, it is suggested to burn excess storage oil by starting the engine with the old spark plugs. Only perform this operation in a well ventilated area.

TROUBLESHOOTING

○ NOTE: The possible causes have been listed in order of frequency. Items should be checked out in the same order as mentioned in the troubleshooting guide.

SYMPTOMS	POSSIBLE CAUSES	WHAT TO DO
Engine turns over but fails to start or starts with difficulty.	1. No fuel to the engine.	Check the tank level. Check for possible clogging of fuel line, item 4.
	2. Flooded engine	Remove wet spark plug, turn ignition to OFF and crank engine several times. Install clean dry spark plug. Start engine following usual starting procedure. If engine continues to flood, see your authorized dealer.
	3. Spark plug/ignition	Check that emergency cut-out switch is at the upper position (ON) and the tether cut-out switch cap is snapped over the receptacle.
		Check for fouled or defective spark plug. Disconnect spark plug wire, unscrew plug and remove from cylinder head. Reconnect wire and ground exposed plug on engine cowl, being careful to hold away from spark plug hole . Follow engine starting procedure and check for spark. If no spark appears, replace spark plug. If trouble persists, contact your authorized dealer.
	4. Clogged fuel line (water or dirt)	Change fuel filter if necessary. Check condition of fuel lines and connections. Check the cleanliness of fuel tank.
	5. Carburetor	Contact your authorized dealer for repair.
	6. Too much oil in fuel	Oil injection pump system: See an authorized dealer for pump adjustment.
		System with gas/oil mixed in tank: Drain the fuel tank and refill with the correct gas/oil mixture.
7. Engine timing	Engine timing may be incorrect or out of adjustment. Contact your authorized dealer.	
8. Engine compression	Running with a lean fuel mixture may produce excessive engine wear resulting in poor engine compression. If this occurs, contact your authorized dealer at once.	

SYMPTOMS	POSSIBLE CAUSES	WHAT TO DO
Engine does not turn manually.	1. Seized engine	In the case of a seized engine contact your authorized dealer.
Engine lacks acceleration or power.	1. Fouled or defective spark plug	Check item 3 of "Engine turns over but fails to start or starts with difficulty".
	2. Clogged fuel line (water or dirt)	Check fuel line condition. (See item 4 of "Engine turns over but fails to start or starts with difficulty").
	3. Carburetor	Contact your authorized dealer.
	4. Ignition	First check item 3 of "Engine turns over but fails to start or starts with difficulty". If the ignition system still seems faulty, contact your authorized dealer.
	5. Engine	If unable to locate specific symptoms, contact your authorized dealer.
Engine continually backfires.	1. Faulty spark plug	Check item 3 of "Engine turns over but fails to start or starts with difficulty".
	2. Overheated	Carburetor set too lean, contact your authorized dealer.
	3. Engine timing incorrectly set	Contact your authorized dealer.
Snowmobile cannot reach full speed.	1. Drive Belt	Check for damaged or worn drive belt. Replace if necessary.
	2. Incorrect track adjustment	Check track tension and alignment. Readjust to specifications. (See Maintenance Section).
	3. Engine	Check item 1 to 5 of "Engine lacks acceleration or power".
	4. Pulley misaligned	Contact your authorized dealer.

TOOLS

As standard equipment each new snowmobile is supplied with basic tools such as screwdriver, wrenches, emergency starter rope, etc.

Standard Tools

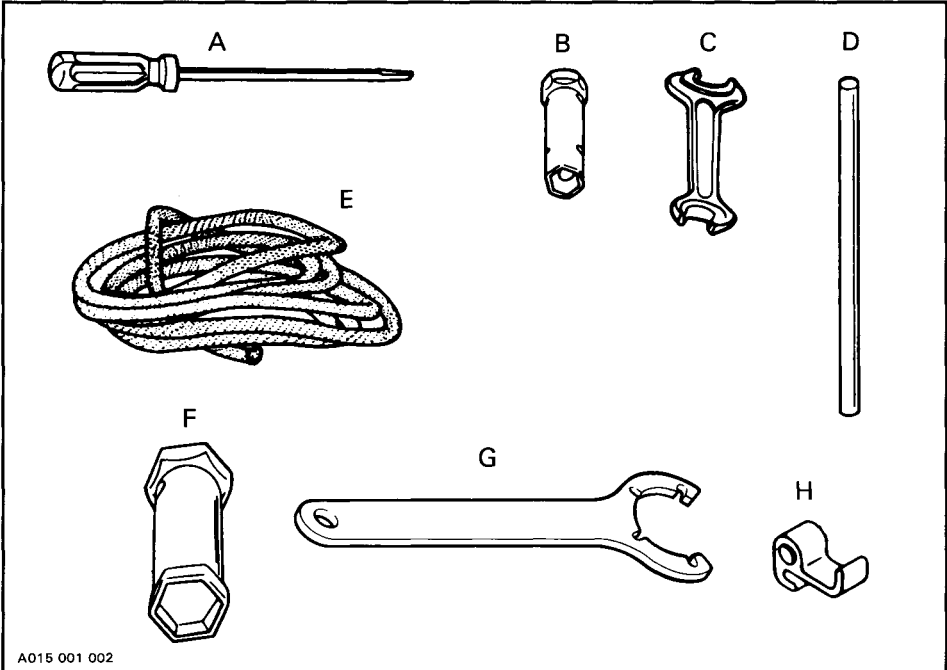

A015 001 002

- | | |
|-----------------------------|------------------------------------|
| A. Screwdriver | F. Socket 21/26 mm |
| B. Socket 10/13 mm | G. Spring Collar
Adjustment Key |
| C. Open End Wrench 10/13 mm | H. Emergency Starter Clip |
| D. Socket Wrench Handle | |
| E. Starter Rope | |

SPECIFICATIONS

	FORMULA MX	FORMULA MX LT
ENGINE		
Type	467	467
No of cylinders	2	2
Bore	69.5 mm (2.736 in)	69.5 mm (2.736 in)
Stroke	61.0 mm (2.402 in)	61.0 mm (2.402 in)
Displacement	462.8 cm ³ (28.24 in ³)	462.8 cm ³ (28.24 in ³)
Compression ratio (corrected)	7.5:1	7.5:1
Maximum horsepower R.P.M.*	7000 R.P.M.	7000 R.P.M.
Carburetor type	Variable Venturi, float type	
Carburetor adjustment:		
— air screw	1 1/2 turn	1 1/2 turn
— idle speed	1800-2000 R.P.M.	1800-2000 R.P.M.
Cooling system capacity:		
— SI	4.2 L	4.2 L
— Imp.	148 oz	148 oz
— U.S.	142 oz	142 oz
Antifreeze/water mixture (% by volume)	60/40	60/40
Thermostat	43°C (110°F)	43°C (110°F)
Radiator pressure cap	90 kPa (13 lb/in ²)	90 kPa (13 lb/in ²)
Torque:		
— engine head nuts	M8: 20 N•m (15 lbf•ft)	M8: 20 N•m (15 lbf•ft)
— crankcase nuts	M6: 9 N•m (80 lbf•in)	M6: 9 N•m (80 lbf•in)
	M8: 20 N•m (15 lbf•ft)	M8: 20 N•m (15 lbf•ft)
— magneto ring nut	M22: 100 N•m (74 lbf•ft)	M22: 100 N•m (74 lbf•ft)
— crankcase/engine support screws	M8: 25 N•m (18 lbf•ft)	M8: 25 N•m (18 lbf•ft)
— exhaust manifold bolts	M8: 21 N•m (15 lbf•ft)	M8: 21 N•m (15 lbf•ft)
CHASSIS		
Length overall	271.8 cm (107 in)	271.8 cm (107 in)
Width overall	104.1 cm (41 in)	104.1 cm (41 in)
Height overall	99 cm (39 in)	99 cm (39 in)
Ski stance (center to center)	92.1 cm (36.25 in)	92.1 cm (36.25 in)
Torque:		
— steering arm/ski leg bolt	25 N•m (18 lbf•ft)	25 N•m (18 lbf•ft)
— steering column/handlebar	26 N•m (19 lbf•ft)	26 N•m (19 lbf•ft)
Weight	222.3 kg (490 lb)	240 kg (529 lb)
Bearing area	5968 cm ² (925 in ²)	7626 cm ² (1182 in ²)
Ground pressure	3.72 kPa (.530 lb/in ²)	3.15 kPa (.448 lb/in ²)
BRAKE		
Type	Disc, self-adjusting	
Lining minimum thickness	Fixed pad must project 1 mm (1/32 in) minimum from caliper.	
Control lever adjustment	13 mm (1/2 in) minimum distance from handlebar grip when fully applied.	

N.A.: Not applicable

*The maximum horse R.P.M. is applicable with engine on the vehicle. It may be different under certain circumstances and Bombardier Inc. reserves the right to modify it without any obligation.

	FORMULA MX	FORMULA MX LT
POWER TRAIN		
Track:		
— width	38.1 cm (15 in)	41.9 cm (16.5 in)
— length	290 cm (114 in)	315 cm (124 in)
— tension	30 mm (1 3/16 in) gap between slider shoe and bottom inside of track when exerting a downward pull of 7.3 kg (16 lb) to the track.	
— alignment	Equal distance between edges of track guides and slider shoes.	
Standard gear ratio	22/44	22/44
Drive belt:		
— number	414 5823 00	414 5823 00
— maximum width	35 mm (1 3/8 in)	35 mm (1 3/8 in)
— minimum width	32 mm (1 1/4 in)	32 mm (1 1/4 in)
Chaincase oil	256 ml (9 oz)	256 ml (9 oz)
ELECTRICAL		
Lighting system (output)	12 V 160 W	12 V 160 W
Bulb:		
— headlamp	60/60 W	60/60 W
— tail/stop	5/21 W	5/21 W
— speedometer	5 W	5 W
— tachometer	5 W	5 W
— electric fuel level gauge	2 W	2 W
— temperature gauge	2 W	2 W
Fuse:		
— tachometer	0.1 A	0.1 A
Spark plug:		
— type	NGK BR9ES	NGK BR9ES
— gap	0.4 mm (.016 in)	0.4 mm (.016 in)
Ignition timing:		
— timing mark (B.T.D.C.)	2.51 mm (.099 in)	2.51 mm (.099 in)
— stroboscopic timing	6000 R.P.M.	6000 R.P.M.
FUEL		
Gas type	Regular unleaded	Regular unleaded
Fuel tank capacity:		
— SI	40.9 L	40.9 L
— Imp.	9 gal.	9 gal.
— U.S.	10.8 gal.	10.8 gal.
Injection Oil	BOMBARDIER Snowmobile Injection Oil	
Tank capacity:		
— SI	2.9 L	2.9 L
— Imp.	102 oz	102 oz
— U.S.	98 oz	98 oz

Hal.: Halogen

N.A.: Not applicable

Bombardier Inc. reserves the right to make changes in design and specifications and/or to make additions to, or improvements in its product without imposing any obligation upon itself to install them on its products previously manufactured.

	FORMULA PLUS	FORMULA PLUS LT
ENGINE		
Type	536	536
No of cylinders	2	2
Bore	72.0 mm (2.835 in)	72.0 mm (2.835 in)
Stroke	64.0 mm (2.520 in)	64.0 mm (2.520 in)
Displacement	521.2 cm ³ (31.81 in ³)	521.2 cm ³ (31.81 in ³)
Compression ratio (corrected)	6.12:1	6.12:1
Maximum horsepower R.P.M.*	7250 R.P.M.	7250 R.P.M.
Carburetor type	Variable Venturi, float type	
Carburetor adjustment:		
— air screw	1 1/3 turns	1 1/3 turns
— idle speed	1800-2000 R.P.M.	1800-2000 R.P.M.
Cooling system capacity:		
— SI	4.2 L	4.2 L
— Imp.	148 oz	148 oz
— U.S.	142 oz	142 oz
Antifreeze/water mixture (% by volume)	60/40	60/40
Thermostat	42°C (107°F)	42°C (107°F)
Radiator pressure cap	90 kPa (13 lb/in ²)	90 kPa (13 lb/in ²)
Torque:		
— engine head nuts	M8: 20 N•m (15 lbf•ft)	M8: 20 N•m (15 lbf•ft)
— crankcase nuts	M6: 9 N•m (80 lbf•in)	M6: 9 N•m (80 lbf•in)
	M8: 20 N•m (15 lbf•ft)	M8: 20 N•m (15 lbf•ft)
— magneto ring nut	M22: 100 N•m (74 lbf•ft)	M22: 100 N•m (74 lbf•ft)
— crankcase/engine support screws	M8: 25 N•m (18 lbf•ft)	M8: 25 N•m (18 lbf•ft)
— exhaust manifold bolts	M8: 21 N•m (15 lbf•ft)	M8: 21 N•m (15 lbf•ft)
CHASSIS		
Length overall	271.8 cm (107 in)	271.8 cm (107 in)
Width overall	104.1 cm (41 in)	104.1 cm (41 in)
Height overall	99 cm (39 in)	99 cm (39 in)
Ski stance (center to center)	92.1 cm (36.25 in)	92.1 cm (36.25 in)
Torque:		
— steering arm/ski leg bolt	25 N•m (18 lbf•ft)	25 N•m (18 lbf•ft)
— steering column/handlebar	26 N•m (19 lbf•ft)	26 N•m (19 lbf•ft)
Weight	226.8 kg (500 lb)	240 kg (529 lb)
Bearing area	6348 cm ² (984 in ²)	7226 cm ² (1182 in ²)
Ground pressure	3.57 kPa (.508 lb/in ²)	3.15 kPa (.448 lb/in ²)
BRAKE		
Type	Disc, self-adjusting	
Lining minimum thickness	Fixed pad must project 1 mm (1/32 in) minimum from caliper.	
Control lever adjustment	13 mm (1/2 in) minimum distance from handlebar grip when fully applied.	

N.A.: Not applicable

*The maximum horse R.P.M. is applicable with engine on the vehicle. It may be different under certain circumstances and Bombardier Inc. reserves the right to modify it without any obligation.

	FORMULA MX	FORMULA PLUS LT
POWER TRAIN		
Track:		
— width	41.9 cm (16.5 in)	41.9 cm (16.5 in)
— length	290 cm (114 in)	315 cm (124 in)
— tension	30 mm (1 3/16 in) gap between slider shoe and bottom inside of track when exerting a downward pull of 7.3 kg (16 lb) to the track.	
— alignment	Equal distance between edges of track guides and slider shoes.	
Standard gear ratio	20/38	20/38
Drive belt:		
— number	414 5823 00	414 5823 00
— maximum width	35 mm (1 3/8 in)	35 mm (1 3/8 in)
— minimum width	32 mm (1 1/4 in)	32 mm (1 1/4 in)
Chaincase oil	256 ml (9 oz)	256 ml (9 oz)
ELECTRICAL		
Lighting system (output)	12 V 160 W	12 V 160 W
Bulb:		
— headlamp	60/55 W HAL.	60/55 W HAL.
— tail/stop	5/21 W	5/21 W
— speedometer	5 W	5 W
— tachometer	5 W	5 W
— electric fuel level gauge	2 W	2 W
— temperature gauge	2 W	2 W
Fuse:		
— tachometer	0.1 A	0.1 A
Spark plug:		
— type	NGK BR9ES	NGK BR9ES
— gap	0.4 mm (.016 in)	0.4 mm (.016 in)
Ignition timing:		
— timing mark (B.T.D.C.)	1.75 mm (.69 in)	1.75 mm (.69 in)
— stroboscopic timing	6000 R.P.M.	6000 R.P.M.
FUEL		
Gas type	Regular unleaded	Regular unleaded
Fuel tank capacity:		
— SI	40.9 L	40.9 L
— Imp.	9 gal.	9 gal.
— U.S.	10.8 gal.	10.8 gal.
Injection Oil	BOMBARDIER Snowmobile Injection Oil	
Tank capacity:		
— SI	2.9 L	2.9 L
— Imp.	102 oz	102 oz
— U.S.	98 oz	98 oz

Hal.: Halogen

N.A.: Not applicable

Bombardier Inc. reserves the right to make changes in design and specifications and/or to make additions to, or improvements in its product without imposing any obligation upon itself to install them on its products previously manufactured.

SI* METRIC INFORMATION GUIDE

BASE UNITS

DESCRIPTION	UNIT	SYMBOL
length	meter	m
mass	kilogram	kg
force	Newton	N
liquid	liter	l
temperature	Celsius	°C
pressure	kilopascal	kPa
torque	Newton meter	N•m
speed	kilometer per hour	km/h

PREFIXES

PREFIX	SYMBOL	MEANING	VALUE
kilo	k	one thousand	1000
centi	c	one hundredth	0.01
milli	m	one thousandth	0.001
micro	μ	one millionth	0.000001

CONVERSION FACTORS

TO CONVERT	TO †	MULTIPLY BY
in	mm	25.4
in	cm	2.54
in ²	cm ²	6.45
in ³	cm ³	16.39
ft	m	0.3
oz	g	28.35
lb	kg	0.45
lbf	N	4.4
lbf•in	N•m	0.11
lbf•ft	N•m	1.36
lbf•ft	lbf•in	12
PSI	kPa	6.89
imp. oz	U.S. oz	0.96
imp. oz	ml	28.41
imp. gal.	U.S. gal.	1.2
imp. gal.	l	4.55
U.S. oz	ml	29.57
U.S. gal.	l	3.79
MPH	km/h	1.61
Fahrenheit	Celsius	(°F - 32) ÷ 1.8
Celsius	Fahrenheit	(°C × 1.8) + 32

*The international system of units abbreviates "SI" in all languages.

†To obtain the inverse sequence, divide by the given factor. To convert "mm" to "in", divide by 25.4.

NOTES

NOTES _____

CHANGE OF ADDRESS OR OWNERSHIP

Any change in address or ownership should be brought to the attention of the manufacturer by completing and sending out the card below.

NOTICE TO ALL NEW OWNERS: Make sure to receive the warranty registration card from the previous owner, when the ownership is transferred. Also enclose a photocopy of this registration card when informing of a change of ownership.



CHANGE OF ADDRESS

VEHICLE IDENTIFICATION NUMBER

--	--	--	--	--	--	--	--	--	--	--

OLD ADDRESS:

NAME

NO _____ STREET _____ APT. _____

CITY _____ STATE/PROVINCE _____ ZIP/POSTAL CODE _____

NEW ADDRESS:

NAME

NO _____ STREET _____ APT. _____

CITY _____ STATE/PROVINCE _____ ZIP/POSTAL CODE _____



CHANGE OF OWNERSHIP

VEHICLE IDENTIFICATION NUMBER

--	--	--	--	--	--	--	--	--	--	--

The ownership of this vehicle is transferred

FROM:

NAME

NO _____ STREET _____ APT. _____

CITY _____ STATE/PROVINCE _____ ZIP/POSTAL CODE _____

TO:

NAME

NO _____ STREET _____ APT. _____

CITY _____ STATE/PROVINCE _____ ZIP/POSTAL CODE _____



STAMP

BOMBARDIER INC.
ATT.: WARRANTY DEPARTMENT
VALCOURT (QUEBEC)
CANADA JOE 2LO

STAMP

BOMBARDIER INC.
ATT.: WARRANTY DEPARTMENT
VALCOURT (QUEBEC)
CANADA JOE 2LO