

THIS BOOKLET MUST BE USED IN CONJUNCTION WITH THE 1987
FORMULA MX/MX LT/PLUS OPERATOR'S MANUAL (P/N 414 6063 00)

operator's
manual
supplement for

FORMULA HPO

414 6377 00

Suspension Adjustments

Shock absorber spring preload

The rear suspension has 2 preload adjustments:

- The front shock spring for surface condition.
- The rear shock spring for driver's weight.

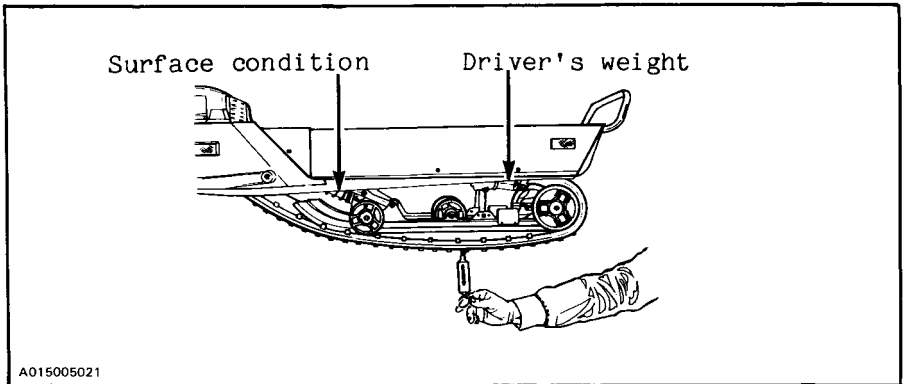

To adjust, use the adjustment key supplied. Spray some WD 40 between spring and spring collar.

▼ **CAUTION:** There must be two thrust washers between spring and spring collar. If any is missing, do not attempt to adjust spring collar and see an authorized dealer for installation.

○ **NOTE:** Shock spring units must always be removed from vehicle to adjust.

Fit the key on the shock spring collar and turn clockwise for stiffest or counterclockwise for softest.

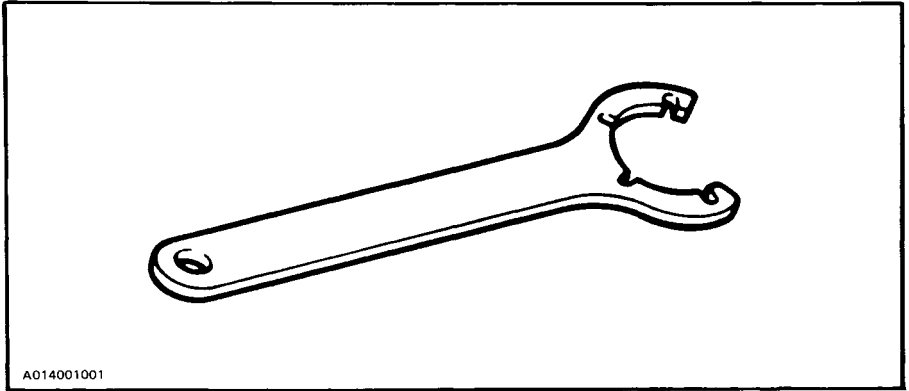

A014001001



CAUTION: Limiter straps are not adjustable on this vehicle.



WARNING: Never operate vehicle with damaged or missing limiter straps.

Track Tension and Alignment

Tension:

Lift the rear of vehicle and support with a mechanical stand. Allow the slide to extend normally. The gap should be 16 mm (5/8 in) between the slider shoe and the bottom inside of the track when a weight of 7.3 kg (16 lb) is applied on the track. If the track tension is too loose, the track will have a tendency to thump.

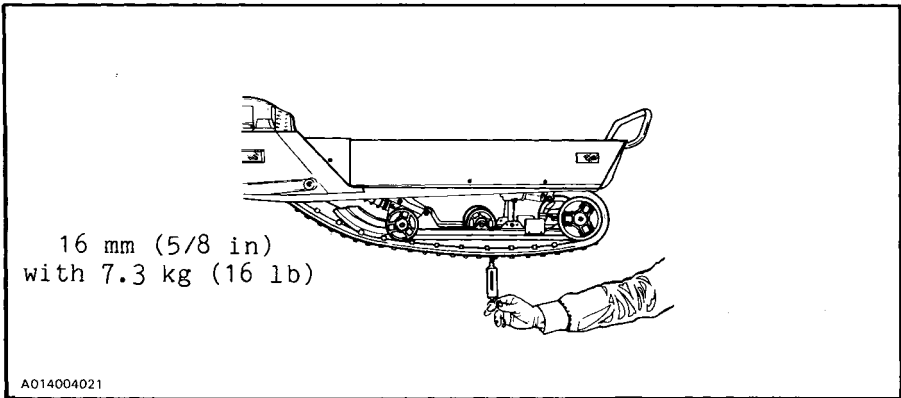

▼ **CAUTION:** Too much tension will result in power loss and excessive stresses on suspension components.

If necessary to adjust; loosen the rear idler wheel retaining screws and the adjuster bolt lock nuts, then loosen or tighten the adjuster screws located on the inner side of the rear idler wheels. If correct tension is unattainable, contact your dealer.

○ **NOTE:** Torque retaining screws to 48 N·m (35 lbf·ft) after adjustment.

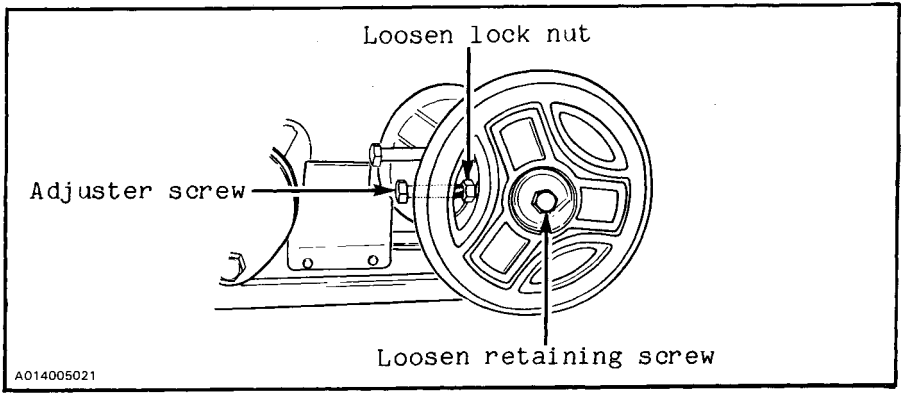

○ **NOTE:** Track tension and alignment are inter-related. Do not adjust one without the other.

