



# MANUEL DU CONDUCTEUR 1982



# Citation

3500  
4500  
\* & SS

® \* Marques de commerce de Bombardier Inc.

modèle \_\_\_\_\_

no d'identification \_\_\_\_\_

date de l'achat \_\_\_\_\_

expiration de la garantie \_\_\_\_\_

Faire remplir par le concessionnaire au moment de la vente

ESTAMPILLE DU CONCESSIONNAIRE

PUBLICATIONS TECHNIQUES  
DIVISION DU SERVICE  
BOMBARDIER INC.  
VALCOURT, QUÉBEC  
CANADA, JOE 2L0

Les marques de commerce suivantes  
sont des marques de Bombardier Inc.

BOMBARDIER	EVEREST	MOTO-SKI
SKI-DOO	CITATION	FUTURA
ALPINE	OLYMPIQUE	SPIRIT
BLIZZARD	T'NT	NUVIK
CARRY-BOOSE	NORDIK	MIRAGE
ÉLAN	SKANDIC	SUPER SONIC
ÉLITE		ULTRA SONIC
GRAND PRIX SPÉCIAL		

# AVANT-PROPOS

Ce manuel du conducteur ainsi que le "Guide de sécurité pour le motoneigiste" ont pour but d'aider le conducteur de motoneige à se familiariser avec son véhicule, son fonctionnement et les différentes phases de son entretien, et de lui fournir de précieux conseils au regard d'une conduite sûre. Chacun de ces manuels devrait être gardé en permanence dans le véhicule.

Pour toute question concernant la garantie et ses applications, veuillez consulter la section "Questions les plus fréquentes", ou adressez-vous à votre concessionnaire.

Le présent manuel fait usage des symboles qui suivent.



**AVERTISSEMENT:** Avertit d'un risque de blessure.



**ATTENTION:** Avertit d'un risque d'endommagement du véhicule ou d'une pièce.



**REMARQUE:** Annonce une information supplémentaire.

Une bonne compréhension des informations données dans ce manuel permettra au conducteur d'utiliser son véhicule de façon adéquate.

La plupart des données sont imprimées à la fois en unités métriques et en unités ordinaires (système anglais). Dans les cas où il n'est pas nécessaire d'obtenir une grande précision, certains résultats de conversion sont complétés en chiffres ronds, pour plus de facilité.

Pour de plus amples informations sur l'entretien et la réparation, il est possible d'obtenir du fabricant un Manuel de réparation complet.

# SÉCURITÉ SUR MOTONEIGE

## **Prenez toujours les précautions suivantes:**

- Vérifiez si l'accélérateur fonctionne librement avant de faire démarrer le moteur.
- Ne faites jamais tourner le moteur lorsque la courroie d'entraînement et le garde-poulie ne sont pas en place.
- Il est dangereux de faire tourner le moteur lorsque le capot n'est pas en place.
- L'essence est un liquide inflammable, donc dangereux. Pour vous en servir, choisissez un endroit bien aéré et arrêtez le moteur. Ne fumez pas. Si vous décelez en cours de route des émanations d'essence, vous devez en déterminer la cause immédiatement et remédier à cette situation.
- Maintenez toujours votre véhicule en parfait état.
- Les motoneiges ne sont pas conçues pour circuler sur l'asphalte, la terre battue ou autres surfaces abrasives. Il en résulte une usure excessive des pièces.
- Les motoneiges ne sont pas conçues pour circuler dans les rues ou sur les routes publiques. Cette pratique est d'ailleurs interdite dans la plupart des provinces et des états.
- N'installez que des pièces de rechange standard et jamais de plaques pour augmenter l'écartement des skis, de pare-chocs ou de porte-bagages, etc., car ces pièces pourraient compromettre la stabilité et la sûreté du véhicule. Évitez d'ajouter des accessoires qui modifieraient la forme de base du véhicule.
- Pour arrêter le moteur, actionnez l'interrupteur d'urgence ou le capuchon coupe-circuit, ou coupez le contact avec la clé.
- Si le véhicule est remis à l'extérieur, le recouvrir d'une bâche opaque.
- Ne lubrifiez pas les câbles d'accélérateur et/ou de frein, ni leur gaine.
- Effectuez toutes les opérations d'entretien de la façon décrite dans ce manuel. Sauf indication contraire, le moteur doit alors être arrêté.
- Nettoyer et vérifier les phares.

---

**VEUILLEZ PRENDRE NOTE DE TOUS LES PASSAGES MARQUÉS "AVERTISSEMENT" ET "ATTENTION" QUI SE TROUVENT DANS CE MANUEL ET SUR LE VÉHICULE.**

---

Ce véhicule est fabriqué de pièces dont les dimensions sont calculées en unités métriques. Toutes les attaches sont conformes au système métrique et ne doivent pas être remplacées par des attaches aux mesures anglaises ordinaires. L'utilisation d'attaches inadéquates ou l'agencement des deux (2) types d'attaches peut entraîner des dommages au véhicule ou d'éventuelles blessures à son conducteur.

**CE MANUEL DOIT DEMEURER AVEC LE VÉHICULE AU MOMENT D'UNE REVENTE.**

# INDEX

<b>THE 1982 "LIMITED WARRANTY"</b> .....	<b>4</b>
<b>OFTEN ASKED QUESTIONS</b> .....	<b>6</b>
<b>LISTING OF AREA DISTRIBUTORS</b> .....	<b>8</b>
<b>HOW TO IDENTIFY YOUR SNOWMOBILE</b> .....	<b>9</b>
<b>CONTROLS/INSTRUMENTS</b>	
Throttle lever, brake lever, ignition light switch, headlamp dimmer switch, emergency cut-out switch, light switch, manual starter handle, primer, tether cut-out switch, speedometer (optional on some models), hood opening, tool box, fuel gauge, spark plug holder, spare drive belt .....	<b>10</b>
<b>BREAK-IN PERIOD</b>	
Break-in, inspection 10-hour, inspection checklist .....	<b>13</b>
<b>FUEL</b>	
Recommended gasoline, recommended oil, injection oil .....	<b>15</b>
<b>PRE-START CHECK</b>	
Check points .....	<b>16</b>
<b>STARTING PROCEDURE</b>	
Manual starting, electric starting, emergency starting .....	<b>16</b>
<b>LUBRICATION</b>	
Frequency, drive pulley, steering mechanism, chaincase oil level, drive axle, suspension .....	<b>19</b>
<b>MAINTENANCE</b>	
Chart, drive belt, new drive belt, pulley guard removal, drive belt removal & installation, brake condition, brake adjustment, brake light switch adjustment, spark plug(s), battery, track condition, track tension and alignment, suspension condition, suspension adjustment, drive pulley, steering mechanism, steering adjustment, muffler attachment, carburetor adjustment, oil injection pump adjustment, fan belt, engine head nuts, engine mount nuts, headlamp beam aiming, bulb replacement, general inspection .....	<b>21</b>
<b>STORAGE</b>	
Track, suspension, skis, controls, chaincase, drive pulley, fuel tank and carburetor, cylinder lubrication, battery, battery removal and installation, chassis, general inspection .....	<b>31</b>
<b>PRE-SEASON PREPARATION</b>	
Pre-season preparation chart .....	<b>35</b>
<b>TROUBLE SHOOTING GUIDE</b> .....	<b>36</b>
<b>TOOLS</b> .....	<b>38</b>
<b>SPECIFICATIONS</b> .....	<b>39</b>
<b>WIRING DIAGRAMS</b> .....	<b>41</b>
<b>SI METRIC INFORMATION GUIDE</b> .....	<b>44</b>
<b>CHANGE OF ADDRESS OF OWNERSHIP</b> .....	<b>47</b>

# LIMITED WARRANTY 1982 SKI-DOO® SNOWMOBILES

## 1 - PERIOD

BOMBARDIER® INC. as manufacturer, warrants FROM THE DATE OF FIRST CONSUMER SALES, every 1982 SKI-DOO® snowmobile, sold as NEW AND UNUSED, by an authorized SKI-DOO dealer, for periods of:

- 12 consecutive months for ELAN® , CITATION\* , EVEREST® , ELITE® , ALPINE® models.
- 90 consecutive days for NORDIK\* , SKANDIC\* , BLIZZARD® 5500 MX and 9500 models subject to the following:
  1. If delivery is made after the 31st day of March of a given year and before the 1st day of December of the same year, the above 90 day warranty will start on December 1st.
  2. If delivery is made on/or after the 2nd day of January of a given year but before the 31st day of March of the same year, all the unused portion of the 90 day period will be carried over to the next winter and start again on the 1st day of December of the same year.

## 2 - WHAT BOMBARDIER WILL DO

BOMBARDIER will repair and/or replace, at its option, components defective in material and/or workmanship (under normal use and service,) with a genuine BOMBARDIER component without charge for parts or labour, at any authorized SKI-DOO dealer during said warranty period.

## 3 - CONDITION TO HAVE WARRANTY WORK PERFORMED

Present to the servicing dealer, the hard copy of the BOMBARDIER Customer Registration card received by the customer from the selling dealer at time of purchase.

## 4 - WARRANTY TRANSFER

This warranty is transferable to subsequent owner(s) for remainder of warranty period from original date of sale.

## 5 - EXCLUSIONS - ARE NOT WARRANTED

- Normal wear on all items such as, but not limited to:
  - drive belts
  - slider shoes
  - spark plugs
  - breaker points
  - runners on skis
- Replacement parts and/or accessories which are not genuine BOMBARDIER parts and/or accessories.
- Damage resulting from installation of parts other than genuine BOMBARDIER parts.
- Damage caused by failure to provide proper maintenance as detailed in the Operator Manual. The labour, parts and lubricants costs of all maintenance services, including tune-ups and adjustments will be charged to the owner.
- A sulphated battery.

- les dommages causés par un manque à satisfaire aux règles d'entretien décrites dans le Manuel du conducteur, étant entendu que toutes les opérations d'entretien y compris les frais de main-d'oeuvre, le coût des pièces, les lubrifiants, les mises au point et/ou les réglages seront aux frais du client;
- les véhicules utilisés lors de compétitions organisées;
- tous les accessoires facultatifs installés sur la motoneige; tous les accessoires et pièces de rechange sont assujettis à leur garantie particulière, s'il en est;
- les dommages résultant d'un accident, d'un incendie ou d'autres événements fortuits, d'une mauvaise utilisation du véhicule, d'un abus ou d'une négligence;
- les dommages résultant de modifications de la motoneige non approuvées par écrit par BOMBARDIER;
- les pertes subies par le propriétaire comme, entre autres, les frais de transport, remorquage, appels téléphoniques, taxi, ou tous autres dommages indirects.

**Certains états ou certaines provinces n'admettent pas l'exclusion ou la limitation portant sur les dommages imprévus ou indirects; par conséquent cette limitation ou exclusion peut ne pas s'appliquer.**

## **6 - GARANTIES EXPRESSES OU IMPLICITES**

**La présente garantie confère des droits spécifiques à son titulaire, lequel peut également avoir d'autres droits juridiques, variables d'un état à l'autre, ou d'une province à l'autre. Là où elle s'applique, la présente garantie remplace expressément toute autre garantie légale ou contractuelle, expresse ou implicite de BOMBARDIER INC., ses distributeurs et/ou ses concessionnaires autorisés, y compris toute garantie d'accommodement pour quelque raison que ce soit; autrement, la durée de la garantie implicite se limite à la durée de la présente garantie. Toutefois, certains états ou certaines provinces n'admettant aucune limite quant à la durée d'une garantie implicite, la limitation ci-avant peut ne pas s'appliquer.**

**Nul n'est autorisé à modifier, verbalement ou par écrit, la présente garantie ni à offrir une autre garantie que la présente. Dans le cas où cette indication ne serait pas respectée, ni BOMBARDIER ni aucune autre personne, ne pourra être tenue responsable de modifications apportées à la présente garantie.**

## **7 - FACE À UN PROBLÈME**

Face à un problème d'entretien ou à quelq' autre difficulté, nous vous suggérons:

1. d'essayer de résoudre le problème avec votre concessionnaire ou son gérant de service;
2. si le concessionnaire ne peut résoudre le problème, d'écrire à votre distributeur régional (voir "Liste des distributeurs" dans le Manuel du conducteur);
3. si votre cas n'est toujours pas réglé, de nous écrire finalement à:

Bombardier Inc.  
 Département de Service  
 Division des produits récréatifs  
 Valcourt, Québec, Canada, J0E 2L0

Janvier 1981

Bombardier Inc.  
 Valcourt, Québec, Canada, J0E 2L0

## QUESTIONS LES PLUS FRÉQUENTES

Q: Pourquoi ma motoneige doit-elle être enregistrée? Car en fait, ma facture atteste la date d'achat de mon véhicule.

*R: Votre garantie est valide chez n'importe quel concessionnaire autorisé du produit en question. La carte d'enregistrement constitue l'élément clé fournissant au concessionnaire tous les renseignements qui lui sont nécessaires pour remplir les formulaires de réclamation sous garantie. Les informations qu'elle contient servent également à communiquer aux clients un éventuel rappel sécuritaire.*

Q: Comment puis-je savoir si mon véhicule a été enregistré auprès du fabricant?

*R: Lorsque vous achetez une motoneige, le concessionnaire doit remplir la Carte d'enregistrement de garantie, puis la faire parvenir au fabricant. VOTRE CONCESSIONNAIRE DOIT VOUS REMETTRE LA COPIE CARTONNÉE DE L'ENREGISTREMENT DE VOTRE VÉHICULE.*

Q: J'ai acheté ma motoneige dans la province de Québec, mais c'est en Ontario que je l'utilise. Est-ce que le concessionnaire de ma région en Ontario peut accepter d'effectuer sur ma motoneige les travaux couverts par la garantie?

*R: Oui, n'importe quel concessionnaire en Amérique du Nord peut effectuer les réparations couvertes par la garantie, à condition que le client lui présente sa Carte d'enregistrement de garantie.*

Q: Où puis-je trouver les renseignements concernant la lubrification et l'entretien de ma motoneige?

*R: Dans le Manuel du conducteur.*

Q: Est-ce que la garantie peut devenir nulle si je n'utilise ou n'entretiens pas ma motoneige neuve exactement comme l'indique le Manuel du conducteur?

*R: La garantie d'une motoneige neuve ne peut devenir nulle. Toutefois, si un bris ou une panne surviennent à la suite d'une utilisation ou d'un entretien non conformes au Manuel du conducteur, CE bris ou CETTE panne ne seront pas couverts par la garantie. Il en va de même des opérations de mise au point effectuées par le client, comme le réglage de l'allumage, du carburateur, de l'injection d'huile et/ou du mélange d'huile.*



Q: Pourriez-vous donner quelques exemples d'usage anormal, de négligence ou d'abus?

*R: Ce sont là des termes généraux dont le sens, dans bien des cas, se recoupe. Pour être plus précis et concret, mentionnons les exemples suivants: fonctionnement du véhicule jusqu'à épuisement d'huile, bris de la chaîne dû à un manque de lubrification, bris d'une pièce dû à une utilisation du véhicule alors qu'une autre pièce était cassée ou endommagée, etc. Pour toute question relative au fonctionnement ou à l'entretien de votre véhicule, bien vouloir consulter votre concessionnaire.*

Q: Quels sont les frais qui reviennent au client pendant la période de garantie?

*R: Tous les frais provenant de l'entretien normal du véhicule, des réparations non couvertes par la garantie, d'accidents, de collisions, de même que le coût de l'huile et des bougies, ainsi que les dommages indirects, comme le stipule la garantie.*

Q: Les pièces de rechange d'origine Bombardier utilisées lors de réparations sous garantie sont-elles couvertes par la garantie?

*R: Oui, toute pièce d'origine Bombardier installée lors d'une réparation sous garantie par un concessionnaire autorisé est couverte jusqu'à expiration de la garantie du véhicule.*

Q: Si je vends ma motoneige pendant que la garantie est encore en vigueur, le nouveau propriétaire pourra-t-il bénéficier du reste de la période de garantie?

*R: Oui, pourvu que le véhicule ait déjà été enregistré auprès du fabricant. Il faut, de plus, que la carte de transfert de propriété qui se trouve à la fin de ce manuel, soit remplie et expédiée à Bombardier Inc.*

Q: Comment puis-je obtenir de l'aide, advenant un problème?

*R: Votre concessionnaire et Bombardier Inc. sont particulièrement soucieux de votre satisfaction, en tant qu'acheteur d'un produit Bombardier.. Normalement tout problème qui pourrait survenir relativement à l'achat ou à l'utilisation de votre motoneige sera réglé par la division du Service ou celle des Ventes, chez votre concessionnaire. Toutefois, il est bien évident qu'en dépit des meilleures intentions de chaque personne en cause, certains malentendus peuvent parfois se produire. Ainsi, en cas de problème qui n'aurait pas été résolu à votre satisfaction, nous vous suggérons de discuter de votre problème avec un des gérants chez votre concessionnaire. Il arrive souvent que les plaintes résultent d'un problème de communication et l'un des gérants saura alors régler promptement la question. Si le problème a déjà été soumis au gérant des ventes ou au gérant de service, contacter le concessionnaire lui-même ou le gérant général.*

# LISTE DES DISTRIBUTEURS

## DISTRIBUTEURS CANADIENS

ALPINE DISTRIBUTORS LIMITED  
Kalamalka Lake Road  
P.O. Box 159  
Vernon, Colombie Britannique, V1T 6M2  
(604) 545-1314  
**Colombie Britannique**

BOMBARDIER INC.  
DISTRIBUTEUR DE L'EST DU  
CANADA  
Division Atlantique  
C.P. 670  
Shediac, Nouveau-Brunswick, E0A 3G0  
(506) 532-4454  
**Îles-de-la-Madeleine, Nouvelle-Écosse,  
Nouveau-Brunswick, Île-du-Prince-  
Édouard**

BOMBARDIER INC.  
DISTRIBUTEUR DE L'EST DU  
CANADA  
Division Québec  
1350 Boulevard Nobel  
Boucherville, Québec, J4B 1A1  
(514) 527-2469 or 655-6121  
**Province de Québec**

BOMBARDIER INC.  
DISTRIBUTEUR DE L'EST DU  
CANADA  
Division de l'Ontario  
230 Bayview Drive  
Barrie, Ontario, L4M 2Y8  
(705) 728-8600  
**Province de l' Ontario**

BROOKS EQUIPMENT LIMITED  
1616 King Edward Street  
C.P. 985  
Winnipeg, Manitoba, R3C 2V8  
(204) 633-7247  
**Manitoba, Saskatchewan**

COMPAGNIE DE LA BAIE D'HUDSON  
165 Boulevard Hymus  
Pointe-Claire, Québec, M4W 1A8  
(514) 697-8500  
**Territoires du Nord-Ouest, District de  
Franklin, Keewatin**

J.W. RANDALL LIMITED  
West Street  
C.P. 1050  
Corner Brook, Terre-Neuve, A2H 6G7  
(709) 634-3533  
**Terre-Neuve, Labrador**

TRACT EQUIPMENT  
14325, 114th Avenue  
Edmonton, Alberta, T5M 2Y8  
(403) 452-9910  
**Alberta, District de Mackenzie, Yukon,  
Territoires du Nord-Ouest**

## DISTRIBUTEURS AMÉRICAINS

BOMBARDIER CORPORATION  
4505 West Superior Street  
C.P. 6106  
Duluth, Minnesota 55806  
(218) 628-2881  
**Dakota du Nord, Minnesota, Wisconsin,  
Illinois, Missouri, Michigan, Indiana,  
Ohio (moins moitié est), Tennessee,  
Kentucky, Virginie de l'Ouest, Virginie,  
Nord de l'Idaho, Nord du Wyoming,  
Montana, Iowa, Washington**

ELLIOTT & HUTCHINS INC.  
East Main Street Road  
Malone, New York 12953  
(518) 483-4411  
**New York, Massachusetts, Connec-  
ticut, Rhode Island, Pennsylvanie,  
New Jersey, Maryland, Delaware,  
District de Columbia, partie Est de  
l'Ohio, Maine, New Hampshire, Vermont**

MILLER EQUIPMENT AND  
RECREATIONAL CENTER  
1049 Whitney Road  
Anchorage, Alaska 99501  
(907) 274-9513  
**Alaska**

# HOW TO IDENTIFY YOUR SNOWMOBILE

The main components of your snowmobile (engine, track and frame) are identified by different serial numbers. It may sometimes become necessary to locate these numbers for warranty purposes or to trace your snowmobile in the event of theft.

ENGINE  
SERIAL  
NUMBER

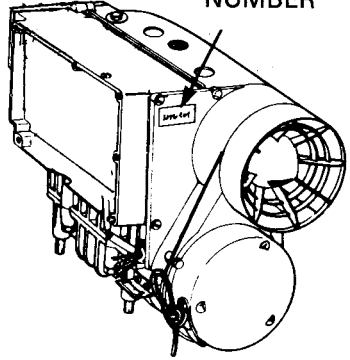

TRACK  
SERIAL  
NUMBER

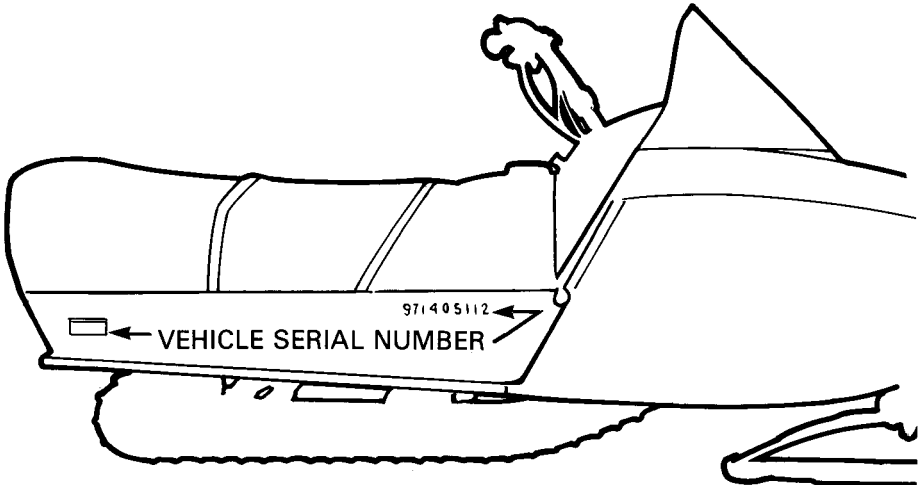
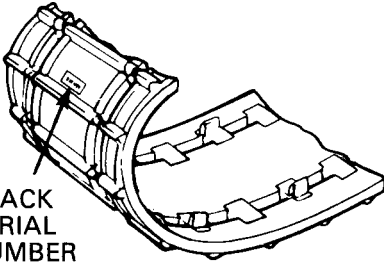

○ **NOTE:** We strongly recommend that you take note of all the serial numbers on your vehicle and supply them to your insurance company. It will surely help in the event a snowmobile is stolen.

# CONTROLS/INSTRUMENTS

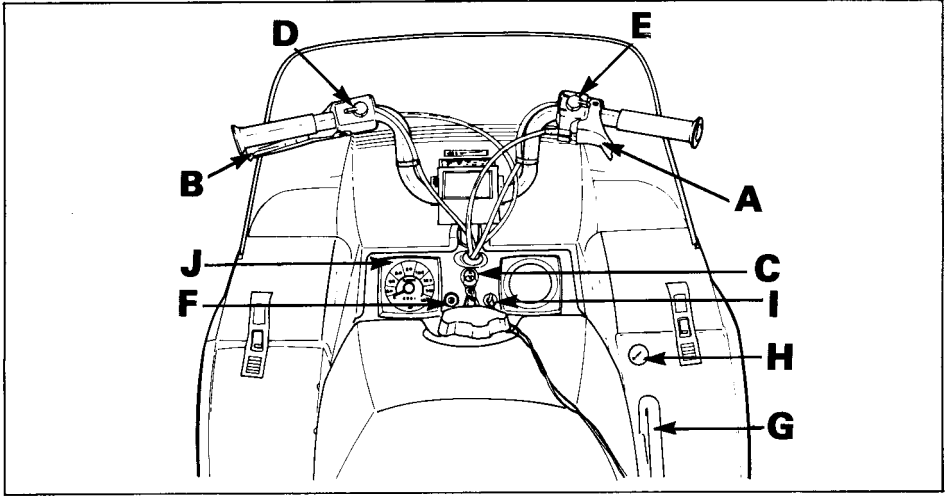

- A) Throttle Control Lever
- B) Brake Control Lever
- C) Ignition/Light Switch
- D) Headlamp Dimmer Switch
- E) Emergency Cut-Out Switch
- F) Light Switch (Electric Model)

- G) Manual Starter Handle
- H) Primer
- I) Tether Cut-Out Switch
- J) Speedometer (Optional on Some Models)

## A) Throttle Lever

Located on right side of handlebar. When compressed, it controls the engine speed and the engagement of the transmission. When released, engine speed returns automatically to idle.

## B) Brake lever

Located on the left side of handlebar. When compressed, the brake is applied. When released, it automatically returns to its original position. Braking effect is proportionate to the pressure applied on the lever and to the type of terrain and it's snow coverage.

## C) Ignition/Light Switch

### Manual Start Models

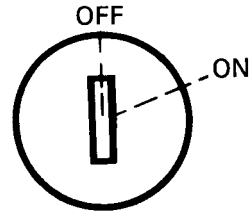

Key operated, 2 position switch. To start engine, first turn key clockwise to ON position. To stop engine, turn key counter-clockwise to OFF position.

The lights are automatically ON whenever the engine is running.

## Electric Start Models

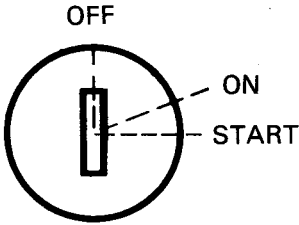

Key operated, 3 position switch. To start engine, turn key fully clockwise to START position and hold. Return key to ON position immediately when engine has started. To stop engine, turn key counter-clockwise to OFF position.

**CAUTION:** Holding key in START position when engine has started could damage starter mechanism.

### D) Headlamp Dimmer Switch

The dimmer switch, located on left side of handlebar, allows correct selection of headlamp beam. To obtain high or low beam simply flick switch.

### E) Emergency Cut-Out Switch

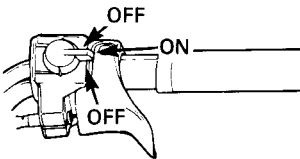

A 3 position switch located on the right side of the handlebar. To stop the engine in an emergency, flick the lever to either upper or lower "OFF" position. To start engine, lever must be in middle "ON" position.

**WARNING:** For safety reasons, the emergency cut-off switch is easily accessible; be careful not to operate it inadvertently.

The driver of this vehicle should familiarize himself with the function of this device by using it several times on first outing. Thereby being mentally prepared for emergency situations requiring its use.

**WARNING:** If the switch has been used in an emergency situation the source of malfunction should be determined and corrected before re-starting engine.

### F) Light Switch (Electric Start Models)

A push pull switch type, to illuminate headlamp and taillight, pull switch knob. (Ignition switch must be turned to ON position).

### G) Manual Starter Handle

Auto rewind type located on right hand side of vehicle. For proper operation, refer to Starting Procedure p. 16.

### H) Primer

A push-pull button. Pull and push button (2-3 times) to activate primer. The primer should always be used for cold engine starts. After engine is warm however, it is not necessary to use primer when starting.

### I) Tether Cut-Out Switch

Attach tether cord to wrist or other convenient location then snap tether cut-out cap over receptacle before starting engine.

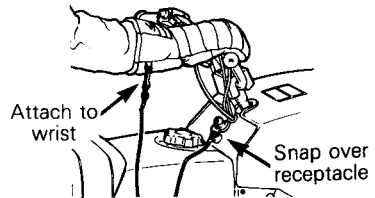

If emergency engine "shut off" is required, completely pull cap from safety switch and engine power will be automatically shut "off".

**NOTE:** The cap must be installed on the safety switch at all times in order to operate the vehicle.

◆ **WARNING:** If the switch is used in an emergency situation the source of malfunction should be determined and corrected before restarting engine.

## J) Speedometer

The speedometer is linked directly to the drive axle. Direct-reading dial indicates the speed of the vehicle. Odometer records the total distance travelled.

## Hood Opening

Pull down the latches to unlock the hood from the anchor.

○ **NOTE:** Always lift hood gently up until stopped by restraining device.

◆ **WARNING:** It is dangerous to run an engine with the hood open unfastened or removed. Personal injury could result.

## Tool Box

Located under the hood. To gain access, tilt hood. Ideal location for spare rope, first aid kit, etc...

## Spark Plug Holder

Spare spark plugs can be carried in the special holes in the air silencer.

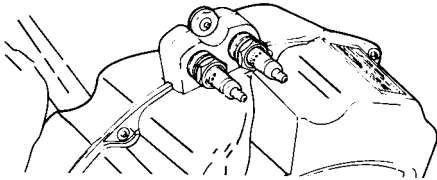

## Fuel Gauge

Unscrew fuel tank cap and withdraw dipstick to check fuel level.

◆ **WARNING:** Never use a lit match or open flame to check fuel level.

## Spare Drive Belt

Can be installed in belly pan clip.

◆ **WARNING:** Always be careful not to burn yourself on the exhaust system when removing or installing drive belt.

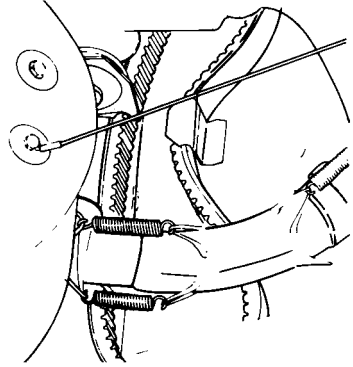

## Fuse

### (Electric Start Models)

Starting system is protected with a 30 amperes rated fuse. Fuse holder is located near the battery. If engine do not start, check fuse condition and if necessary replace.

Instruments are protected with a 15 amperes rated fuse. Fuse holder is located near the ignition switch. If instruments stop operating, check fuse condition and if necessary replace.

## Decompressor

### (For models so equipped)

Two position (OFF /ON), push-pull knob. To engage, pull the decompressor knob fully out.

▼ **CAUTION:** The decompressor provides easier starting by reducing engine compression. However, leaving the decompressor engaged while running will damage your engine. Always disengage after the engine has started.

# BREAK-IN PERIOD

## Break-in

With Bombardier-Rotax snowmobile engines, a break-in period is required before running the vehicle at full throttle. Engine manufacturer recommendation is 10 to 15 operating hours. Maximum throttle should not exceed  $\frac{3}{4}$ , however, brief full acceleration and speed variations contribute to a good break-in. Continued wide open throttle accelerations, prolonged cruising speeds, and lugging are detrimental during the break-in period.

○ **NOTE:** A new drive belt requires a break-in period of 15-25 km (10-15 miles).

## 10-Hour Inspection

As with any precision piece of mechanical equipment, we suggest that after the first 10 hours of operation or 30 days after the purchase, whichever comes first, that your vehicle be checked by your dealer. This inspection will give you the opportunity to discuss the unanswered questions you may have encountered during the first hours of operation.

---

**The 10 hours inspection is at the expense of the vehicle owner.**

---

## 10-HOUR INSPECTION CHECK LIST



Engine timing	
Fan belt tension	
Spark plug(s) condition: (Remove and clean)	
Carburetor adjustment	
Oil injection pump adjustment	
Engine head nuts	
Engine mount nuts	
Muffler attachment	
Chaincase and injection system oil levels	
Brake operation and lining condition	
Ski alignment (runner condition)	
Steering arm, retorque to 42 N•m (31 ft-lbs)	
Handlebar bolts, retorque to 26 N•m (19 ft-lbs)	
Pulley alignment and drive belt condition	
Track condition, tension and alignment	
Lubrication (steering, suspension, drive axle)	
Electrical wiring (loose connections, stripped wires, damaged insulation), tighten all loose bolts, nuts and linkage	
Operation of lighting system (HI / LO beam, brake light, etc.), test operation of emergency cut-out switch and tether switch	

**We recommend that you have your dealer sign this inspection .**

\_\_\_\_\_  
Date of 10 hour inspection

\_\_\_\_\_  
Dealer signature



# FUEL

## Recommended Gasoline

Use regular leaded or unleaded gasoline available from all service stations.

▼ **CAUTION:** Never experiment with different fuel or fuel ratios. Never use naphtha, methanol, gasohol or similar products.

## Recommended Oil

Use concentrated Bombardier snowmobile oil available from your dealer. This type of oil has specially formulated oil bases to meet the lubrication requirements of the Bombardier-Rotax engine.

If Bombardier snowmobile oil is unavailable, substitute with a high-quality 2 cycle snowmobile oil. See oil manufacturer recommendations on container.

▼ **CAUTION:** Never use outboard or straight mineral oils.

## Oil Injection

Always maintain a sufficient amount of Bombardier 50 to 1 snowmobile oil in the injection oil tank.

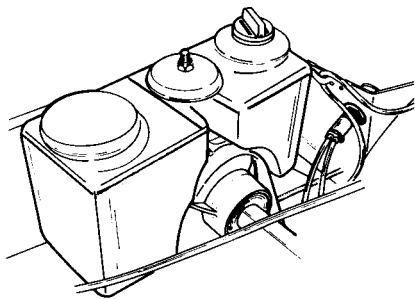

Check level and refill every time you refuel.

## Check Points

- Activate the throttle control lever several times to check that it operates easily and smoothly. The throttle control lever must return to idle position when released.
- Check fuel level.
- Check injection oil level.
- Check that the skis and the track are not frozen to the ground or snow surface and that steering operates freely.
- Activate the brake control lever and make sure the brake fully applies before the brake control lever touches the handlebar grip.
- Verify that the path ahead of the vehicle is clear of bystanders and obstacles.

◆ **WARNING:** Only start your snowmobile once all components are checked and functioning properly.

## Manual Starting

1. Insert the key in the ignition switch and turn to ON position.
  2. TEST THROTTLE CONTROL LEVER.
  3. Activate the primer (2 or 3 times).
- **NOTE:** The use of the primer is not necessary when the engine is warm.
4. Make sure that the tether cut-out cap is in position and that the cord is attached to your clothing. Check that the emergency cut-out switch is in the center ON position.

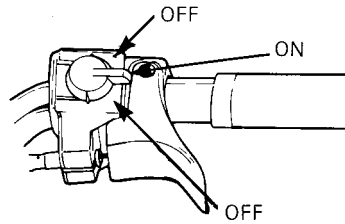

5. Grasp manual starter handle firmly and pull slowly until a resistance is felt then pull vigorously. Slowly release the rewind starter handle.

◆ **WARNING:** Do not apply throttle while starting.

6. Check the operation of the emergency cut-out switch and the tether switch. Restart the engine.

◆ **WARNING:** If engine does not shut-off when applying the emergency cut-out switch and pulling the tether cut-out cap, stop the engine by turning off the ignition key. Do not operate the vehicle further, see your dealer.

7. Allow the engine to warm before operating at full throttle.

## Electric Starting

**CAUTION:** Never operate your snowmobile with the battery removed or disconnected.

1. Insert key in ignition switch.
2. TEST THROTTLE CONTROL LEVER. ACTIVATE PRIMER (2 OR 3 TIMES).

**NOTE:** Primer is not necessary when engine is warm.

3. Make sure that the tether cut-out cap is in position and that the cord is attached to your clothing. Check that the emergency cut-out switch is in the center ON position.
4. Turn ignition key clockwise until starter engages. If engine does not start on first try, key must be turned fully back to OFF each time.

**WARNING:** Do not apply throttle while starting.

5. Released key immediately after engine has started.

**CAUTION:** Holding key in START position when engine has started could damage starter mechanism.

6. Check operation of the emergency cut-out switch and tether switch. Restart engine.

**WARNING:** If engine does not shut-off when applying the emergency cut-out switch and pulling the tether cut-out cap, stop the engine by turning off the ignition key. Do not operate the vehicle further, see your dealer.

7. Allow the engine to warm before operating at full throttle.

## Emergency Starting

### Single Carburetor Models (with roller round shaft pulley)

Should the rewind starter rope fray and break, the engine can be started with an emergency starter rope.

**WARNING:** Do not start the vehicle by the drive pulley unless it is a true emergency situation, have the vehicle repaired as soon as possible.

Remove the pulley guard from vehicle.

Refer to pulley guard removal procedure page 22.

Assemble the emergency starting clip and handle to the emergency starting rope and wind the rope tightly around the drive pulley.

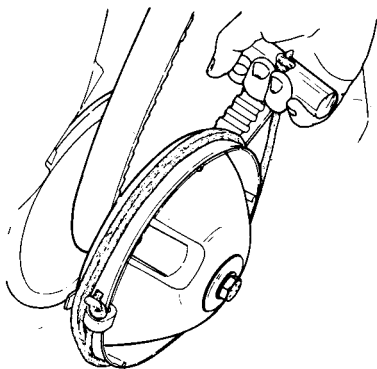
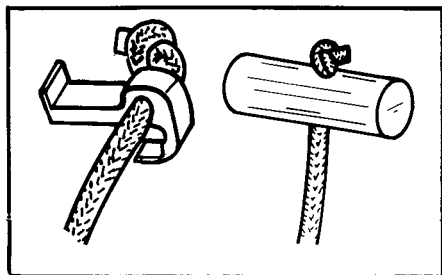

◆ **WARNING:** Do not wind starting rope around your hand. Hold rope by the handle only.

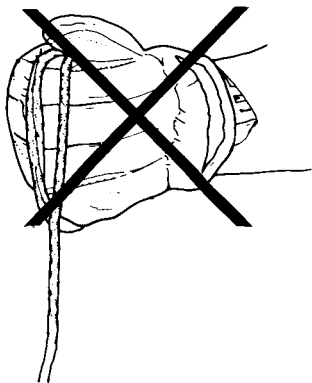

◆ **WARNING:** When starting the vehicle in an emergency situation by the drive pulley, do not make a knot at the end of the emergency rope and do not reinstall the pulley guard.

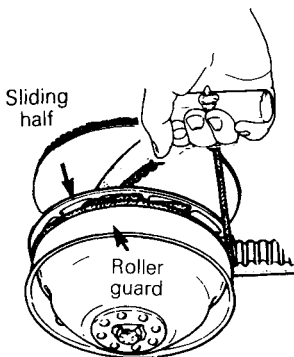

Start as per manual starting procedure.

◆ **WARNING:** When starting the vehicle in an emergency situation by the drive pulley do not reinstall the pulley guard.

### **Dual Carburetor Models (with roller square shaft pulley)**

Remove the pulley guard from the vehicle and wind the emergency rope tight around the drive pulley between the sliding half and the roller guard. Start the engine as per usual manual starting.

# LUBRICATION

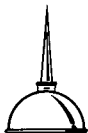

## Frequency

Routine maintenance is necessary for all mechanized products, and the snowmobile is no exception. A weekly vehicle inspection contributes to the life span of the snowmobile as well as retains safe and dependable operation.

◆ **WARNING:** Only perform such procedures as detailed in this manual. It is recommended that dealer assistance be periodically obtained on other components/systems not covered in this manual. Unless otherwise specified, engine should be turned OFF for all lubrication and maintenance procedures.

## Drive Pulley

**(Roller round shaft type single carburetor models)**

This drive pulley requires lubrication bi-monthly or every 20 hours of operation.

◆ **WARNING:** The lubrication of the drive pulley should be performed only by an authorized dealer. A disassembly, cleaning, inspection and lubrication where applicable should also be performed by the dealer every 50 operating hours or at the end of each season, whichever occurs first.

## Steering Mechanism

◆ **WARNING:** Do not lubricate throttle and/or brake cables and housings.

Lubricate the ski legs at grease fittings until new grease appears at joints. Coat spring slider cushion with grease.

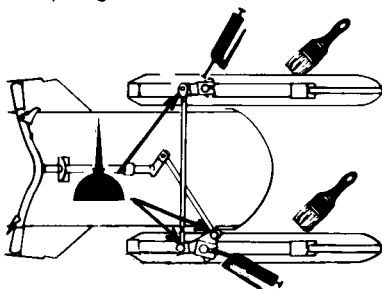

Oil spring coupler bolts.

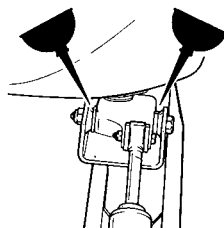

## Chaincase Oil Level

Check the oil level by removing the oil level cap plug.

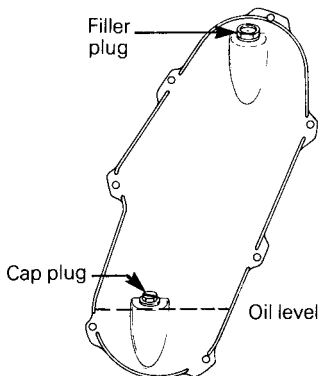

The oil should be level with the bottom of the oil level orifice.

○ **NOTE:** The chaincase oil capacity is approximately 200 mL (7 oz.).

## Drive Axle

Lubricate at grease fitting using low temperature grease.

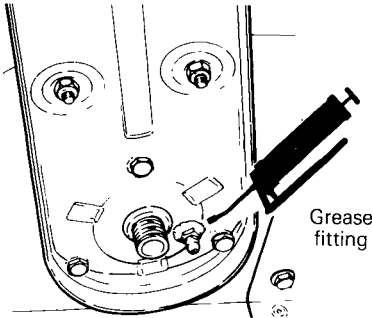

## Suspension

Lubricate idler wheels at grease fittings until grease appears at joints. Use low temperature grease only.

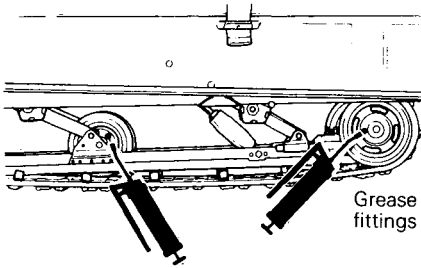

It is recommended that the steering system and suspension be lubricated monthly or every 40 hours of operation. If the vehicle is operated in wet snow or in severe conditions these items should be lubricated more frequently.

# MAINTENANCE

The following Maintenance Chart indicates regular servicing schedules to be performed by you or your servicing dealer. If these services are performed as suggested, your snowmobile will give you many years of low-cost use.

**WARNING:** Only perform such procedures as detailed in this manual. It is recommended that dealer assistance be periodically obtained on other components/systems not covered in this manual. Unless otherwise specified, engine should be turned OFF for all lubrication and maintenance procedures.

<b>MAINTENANCE CHART</b>	Weekly or every 240 km (150 m)	Monthly or every 800 km (500 m)	Once a year or every 3200 km (2000 m)	Refer to page
Drive belt condition	●			22
Brake condition	●			24
Brake adjustment		●		24
Spark plug(s)		●		24
Battery	●			25
Track condition		●		25
Track tension and alignment		●		26
Suspension condition		●		27
Suspension adjustment		●		27
Drive pulley		●		27
Steering mechanism		●		28
Steering adjustment		●		28
Muffler attachment		●		28
Carburetor adjustment			●	29
Oil injection pump adjustment			●	29
Fan belt			●	29
Engine head nuts			●	30
Engine mount nuts			●	30
Headlamp beam aiming			●	30
General inspection		●		31



**NOTE:** The ten hour inspection is a very important part of proper service and maintenance.

## Drive Belt Condition

Inspect belt for cracks, fraying or abnormal wear (uneven wear, wear on one side, missing cogs, cracked fabric). If abnormal wear is noted, probable cause could be pulley misalignment, excessive R.P.M. with frozen track, fast starts without warm-up period, burred or rusty sheave, oil on belt or distorted spare belt. Contact your dealer.

Check the drive belt width. If less than 2.7 cm (1 1/16 in), replace the drive belt.

## New Drive Belt

When installing a new drive belt, break-in period of 25 km (15 miles) is strongly recommended.

○ **NOTE:** Always store a spare belt in a manner to allow its natural shape to be maintained.

## BELT & GUARD REMOVAL

### Pulley Guard Removal

◆ **WARNING:** Pulley guard should always be in place when engine is running.

- A. Raise the hood and remove the retaining clip of the rear pin and remove the pin.
- B. Pull the guard out of the center retaining bolt.
- C. Remove the guard.

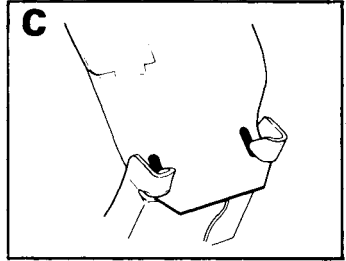
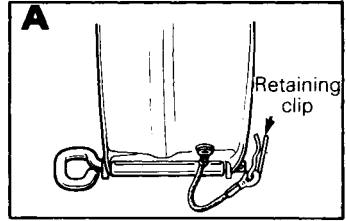
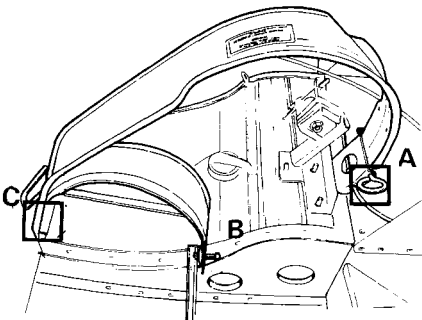

## Drive belt removal and installation

◆ **WARNING:** At the removal or installation of the drive belt be careful not to burn yourself on the exhaust muffler.

1. Remove the pulley guard.
2. Loosen the countershaft bearing retaining screw and open the bearing cage.

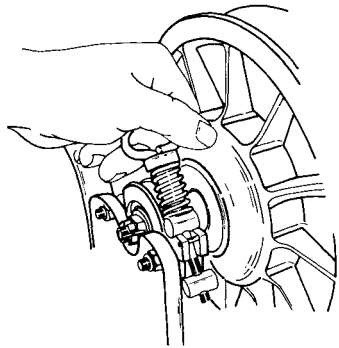



- Open the driven pulley by twisting and pushing the sliding half. Hold in fully open position.

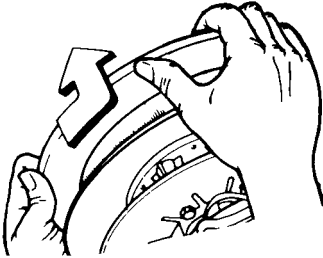

- Slip the belt over the top edge of the sliding half.

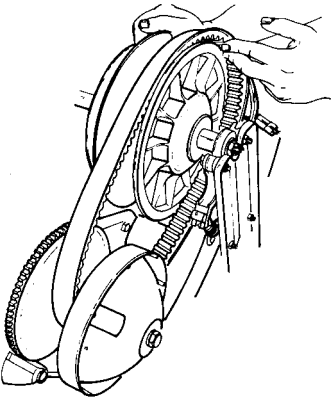

- Lift the countershaft upward approx. 50 mm (2 in.) and slip the belt between the shaft and the bearing cage to remove completely.

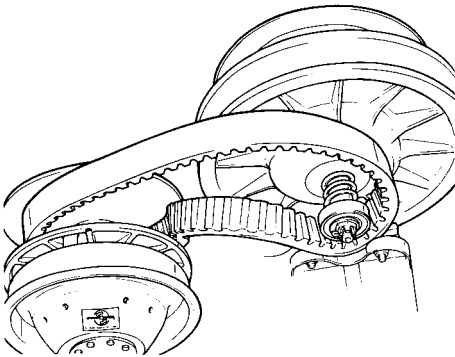

○ **NOTE:** It may be necessary to loosen the brake adjustment in order to easily lift the countershaft.

Slip the belt out from the drive pulley.

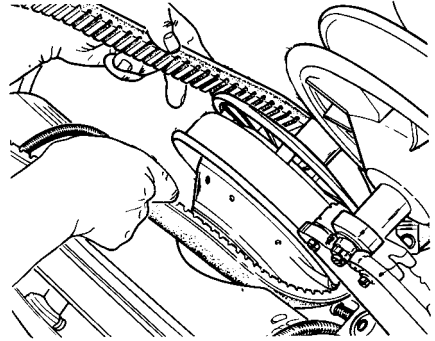

◆ **WARNING:** After drive belt installation, always check that the brake disc is correctly installed between the brake pads and that the brake is well adjusted. Check brake light operation.

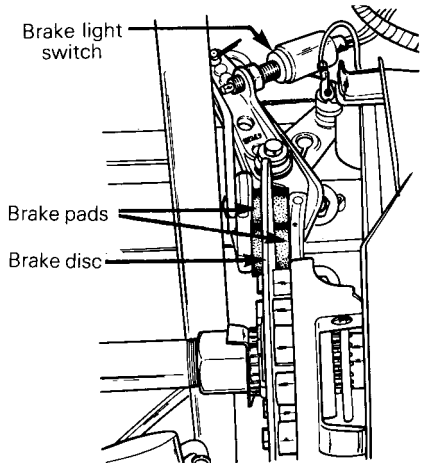

To install the drive belt, reverse the procedure.

▼ **CAUTION:** Once belt is installed, be sure to secure the countershaft bearing by closing the bearing cage and firmly tightening the retaining screw.

## Brake Condition

The brake mechanism on your snowmobile is an essential safety device. Keep this mechanism in proper working condition. Above all, do not operate your snowmobile without an effective brake system.

◆ **WARNING:** Brake pucks less than 3 mm (1/8") thick must be replaced. Replacement must be performed by an authorized dealer.

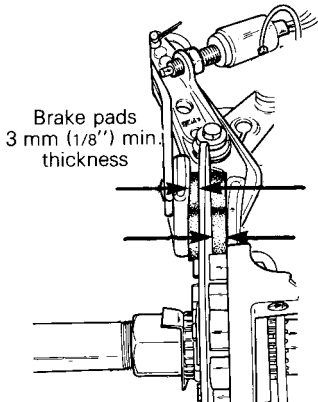

## Brake Adjustment

Brake should apply fully while brake control lever is still 13 mm (1/2") approximative from the handlebar grip.

If adjustment is required, turn the brake cable adjuster counter-clockwise until the brake disc is hard to turn then back off the adjuster to approximately 1 1/2 turn. Recheck brake operation.

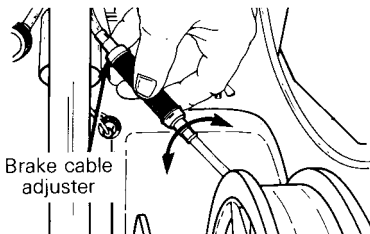

◆ **WARNING:** Whenever the brake is readjusted, the brake light switch operation must also be checked and adjusted as needed.

## Brake Light Switch Adjustment

To check operation:

Pull the brake lever to hold the pads on the disc. Check that a light resistance is felt while rotating the driven pulley. This is the position where the switch should have lit the brake light.

To adjust:

- Loosen the brake switch lock nut.
- Holding brake lever at the lit position, unscrew the switch to light on or screw it in to put out the light.

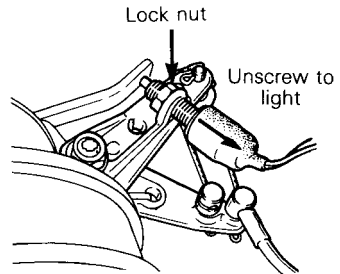

- Tighten the brake switch lock nut and recheck brake light operation.

## Spark Plug(s)

Disconnect the spark plug wire(s) and remove the spark plug(s).

Check the condition of the plug(s).

- A brownish tip reflects ideal conditions. (Correct carburetor, spark plug heat range; etc.).
- A black insulator tip indicates fouling caused by: carburetor idle speed mixture too rich, incorrect fuel mixture ratio, wrong type of spark plug (heat range), or excessive idling.

- A light grey insulator tip indicates a lean mixture caused by: carburetor high speed mixture adjusted too lean, wrong spark plug heat range, incorrect fuel mixture ratio, or a leaking seal or gasket.

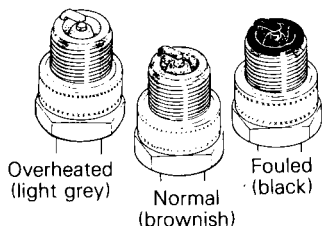

**CAUTION:** If spark plug condition is not ideal, contact your authorized dealer.

Check spark plug gap using a wire feeler gauge.

Reinstall plug(s) and connect wire(s).

### Battery (Electric Start Models)

Check electrolyte level weekly. Electrolyte level must be at upper level line on battery casing.

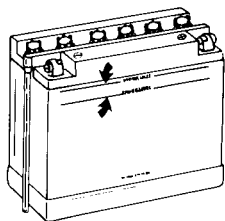

If necessary add distilled water. Battery connections must also be free of corrosion. If cleaning is necessary remove corrosion using a stiff brush then clean with a solution of baking soda and water. Rinse and dry well.

**CAUTION:** Do not allow cleaning solution to enter battery. It will destroy the chemical properties of the electrolyte.

After reconnecting battery, coat battery terminals and connectors with petroleum jelly to prevent corrosion. Check that battery is well secured and that battery overflow tube is not blocked or kinked.

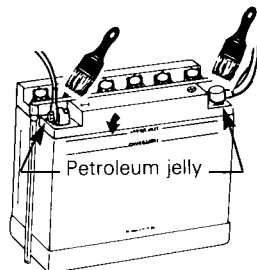

**WARNING:** Overflow tube must be free and open. A kinked or bend tube will restrict ventilation and create gas accumulation that could result in an explosion. Avoid skin contact with electrolyte.

**CAUTION:** Prior to charging the battery, always remove it from the vehicle to prevent electrolyte spillage.

**NOTE:** Always keep battery fully charged.

### Track Condition

Lift the rear of the vehicle and support it off the ground. With the engine off, rotate the track by hand, and inspect condition. If worn, cut or track fibers are exposed or missing or defective inserts or guides are noted, contact your dealer.

**WARNING:** Do not operate a snowmobile with a cut, torn or damaged track.

## Track Tension and Alignment

### Tension:

Lift the rear of vehicle and support with a mechanical stand. Allow the slide to extend normally. Check the gap 13 mm (1/2") between the slider shoe and the bottom inside of the track. If the track tension is too loose, the track will have a tendency to thump.

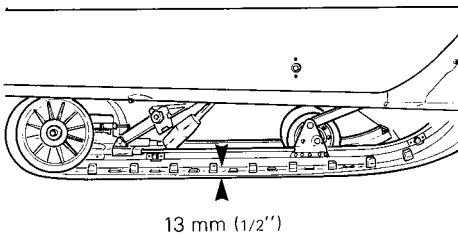

**CAUTION:** Too much tension will result in power loss and excessive stresses on suspension components.

If necessary to adjust. Loosen the rear idler wheel retaining screw and the adjuster bolt lock nut; then loosen or tighten the adjuster bolts located on the inner side of the rear idler wheels. If correct tension is unattainable. Contact your dealer.

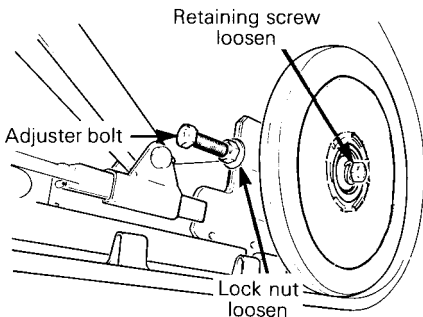

**NOTE:** Track tension and alignment are inter-related. Do not adjust one without the other.

### Alignment

Start the engine and accelerate slightly so that track turns slowly. Check that the track is well centered; equal distance on both sides between edges of track guides and slider shoes.

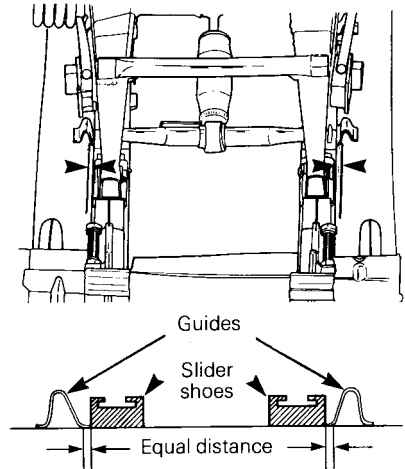

**WARNING:** Before checking track alignment, ensure that the track is free of all particles which could be thrown out while track is rotating. Keep hands, tools, feet and clothing clear of track. Ensure no-one is standing in close proximity to the vehicle.

To correct, stop the engine, loosen the rear idler wheels retaining screws then loosen the lock nuts and tighten the adjuster bolt on side where the slider shoe is the furthest to the track insert guides.

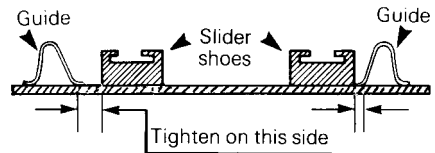

Tighten lock nuts and recheck the alignment. Ensure to retighten the idler wheel retaining screws.

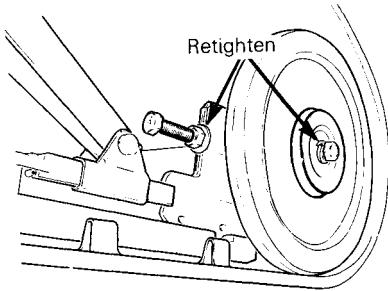

### Suspension Condition

Visually inspect all suspension components including slider shoes, springs, wheels, etc...

○ **NOTE:** During normal driving, snow will act as a lubricant and coolant for the slider shoes. Extensive riding on ice or sanded snow, (not to mention dirt, asphalt, etc. never recommended) will create excessive heat build-up and cause premature slider shoe wear.

### Suspension Adjustment

The suspension is adjustable, the front adjustment for surface condition, the rear for driver's weight.

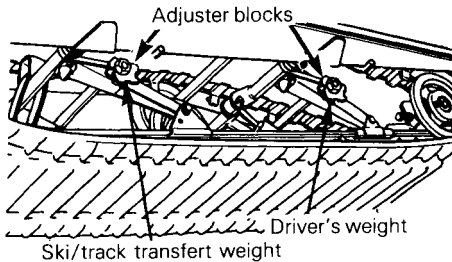

When the front adjuster blocks are at the lowest elevation more weight is distributed on the skis.

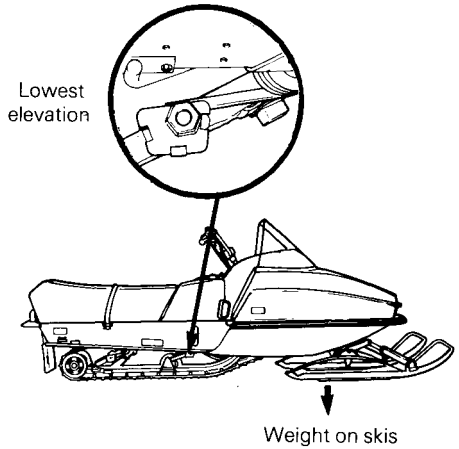

At the highest position the weight is transferred to the track. The rear adjuster blocks should be adjusted to suit the driver's preference.

▼ **CAUTION:** Always turn the left side adjuster blocks in a clockwise direction, the right side blocks in a counter-clockwise direction. Left and right adjuster blocks of each adjustment must always be set at the same elevation.

### Drive Pulley (roller square shaft type, dual carburetor models only)

Inspect the Duralon bushing condition by checking the free-play of the sliding half pulley. This is achieved by restraining the inner half and checking if the sliding half moves in the direction of the arrows more than 3 mm (1/8"). If so, contact your dealer.

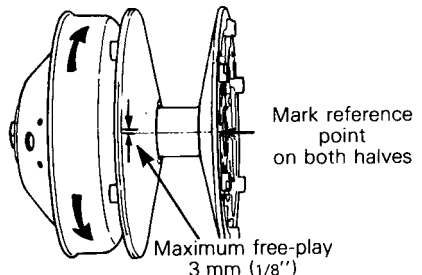

## Drive Pulley (roller round shaft type, single carburetor models)

This drive pulley requires lubrication bi-monthly or every 20 hours of operation.

◆ **WARNING:** The lubrication of the drive pulley should be performed only by an authorized dealer. A disassembly, cleaning, inspection and lubrication where applicable should also be performed by the dealer every 50 operating hours or at the end of each season, whichever occurs first.

## Steering Mechanism

Inspect the steering mechanism for tightness of components (steering arms, tie rods, ball joints, spring coupler bolts, etc.). If necessary, replace or retighten.

Torque steering arm bolts to 42 N•m (31 ft-lbs).

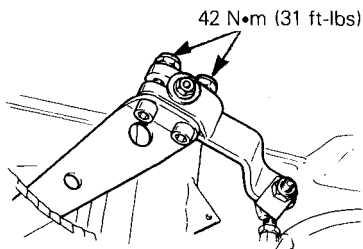

Check the condition of the skis and the ski runners. Replace if more than half worn.

## Steering Adjustment

Skis should have a toe out of 3 mm (1/8"). To check, measure the distance between each ski at the front and rear of the leaf springs. The front distance should be 3 mm (1/8") more than the rear when the handlebar is horizontal.

**IMPORTANT:** Close the front of the skis manually to eliminate all slack from the steering mechanism.

If adjustment is required:

Loosen the lock nuts of the longer tie rod. Turn the tie rod manually until the skis are properly aligned. Firmly retighten the lock nuts.

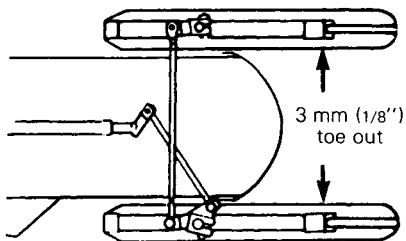

The handlebar should also be horizontal when the skis are pointed toward the front.

To adjust:

Loosen the lock nuts of the shorter tie rod. Turn the tie rod manually until the handlebar is horizontal. Retighten the lock nuts firmly.

◆ **WARNING:** The ball joint socket must run parallel with the steering arm. The steering arm must be restrained when tightening the tie rod end lock nuts.

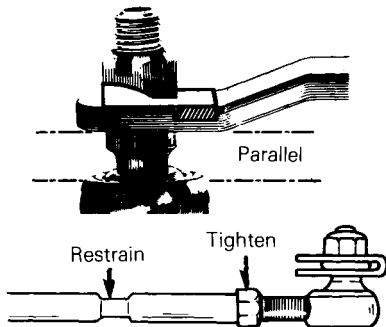

## Muffler Attachment

The engine/muffler attaching parts are vital toward efficient muffler function. Check all attachments. Replace the springs and/or tighten if necessary.

## Carburetor Adjustment

▼ **CAUTION:** Never operate your snowmobile with the air intake silencer disconnected. Serious engine damage will occur if this notice is disregarded.

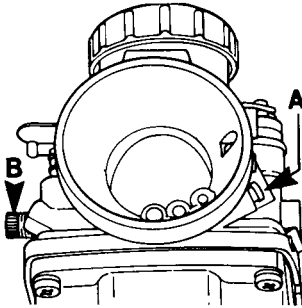

### A) Air Screw Adjustment

Completely close the air screw (until a slight reseating resistance is felt) then back off screw as specified.

### B) Idle Speed Adjustment

Turn the idle speed screw clockwise until it contacts the throttle slide then continue turning two (2) additional turns. This will provide a preliminary idle speed setting. Start the engine and allow it to warm then adjust the idle speed as per specifications by turning the idle speed screw clockwise or counter-clockwise.

▼ **CAUTION:** Do not attempt to set the idle speed by using the air screw. Severe engine damage can occur. If idle speed is unattainable contact your authorized dealer.

## Oil Injection Pump Adjustment

Proper oil injection pump adjustment is very important. Any delay in the opening of the pump can result in serious engine damage.

**TO CHECK ADJUSTMENT:** eliminate the throttle cable free-play by pressing the throttle lever until a light resistance is felt then hold in place. The aligning marks on the pump casting and lever must align perfectly. If not, contact your dealer.

Injection pump should be adjusted by your dealer.

○ **NOTE:** The oil injection pump synchronizing marks can be seen by placing a mirror between the side pan and the pump.

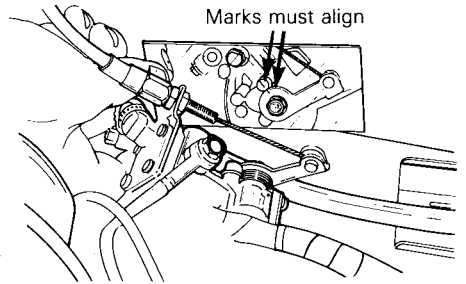

## Fan Belt

Inspect belt for cracks, uneven wear, etc. Check fan belt tension, 6 mm (1/4") free-play should exist when deflection is correct.

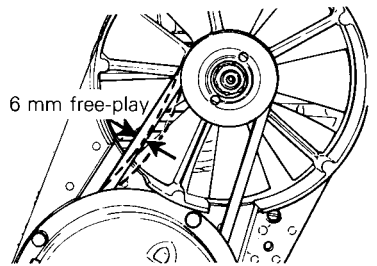

If belt seems damaged or if tension is incorrect, contact your dealer immediately.

◆ **WARNING:** If fan protector is removed, always reinstall after servicing.

## Engine Head Nuts

With the ENGINE COLD, check that the engine head nuts are tight and equally torqued to 22 N•m (16 ft-lbs).

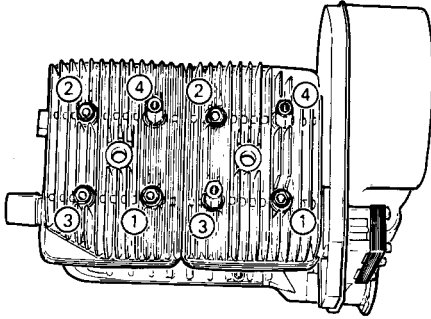

Following sequence above shown, torque engine head nuts twice.

**IMPORTANT:** The engine head nut torque should be checked after the first 5 hours of operation.

## Engine Mount Nuts

Check the engine mount nuts for tightness. Retighten if necessary.

## Headlamp Beam Aiming

The angle of the headlamp beam has been pre-adjusted prior to delivery. Should you wish re-adjustment, place the vehicle on a flat surface 7.6 m (25') from a wall or screen.

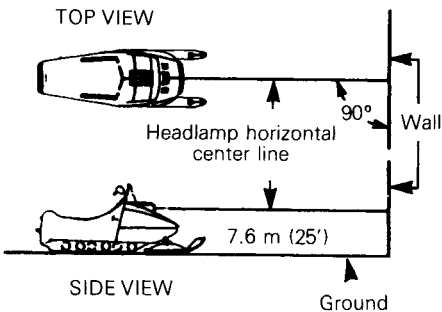

With the suspension correctly adjusted, the rider seated on the vehicle and the high beam ON check that the center of high intensity zone of high beam is 50 mm (2") below horizontal line of headlamp height.

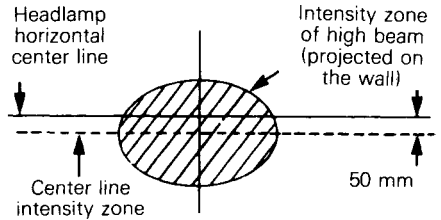

To adjust, remove the four caps, turn upper or lower adjusting screws to obtain desired beam position.

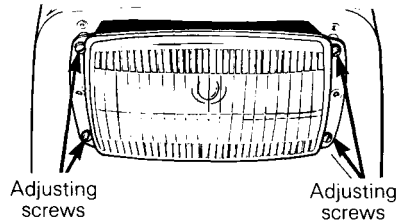

## Headlamp Bulb Replacement

If the headlamp bulb is burnt, tilt hood, unplug the connector from the headlamp. Remove the rubber boot and unfasten bulb retainer clips. Detach the bulb and replace.

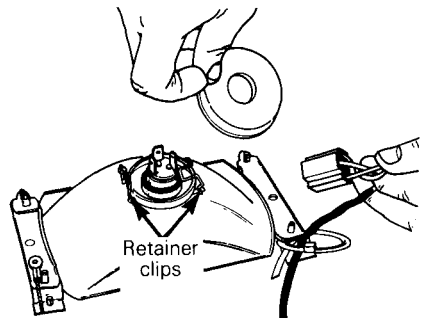



## Taillight Bulb Replacement

If taillight bulb is burnt, expose the bulb by removing the red plastic lens. To remove, unscrew the two (2) Phillips head screws.

◆ **WARNING:** Always check light operation after bulb replacement.

## General Inspection

Check the electrical wiring and components, retighten loose connections. Check for stripped wires or damaged insulation. Thoroughly inspect the vehicle and tighten loose bolts, nuts and linkage. Inspect skis and ski runners for wear.

It is during summer, or when a vehicle is not in use for any length of time that proper storage is a necessity. Storage of the snowmobile during long period of inactivity consists of checking and replacing missing, broken or worn parts, proper lubrication and treatment to insure that parts do not become rusted; cleaning items such as carburetor of oil mixtures, to prevent gum varnish formation within the carburetor; and in general, preparing the vehicle so that when the time comes to use the snowmobile again it will start and be in top condition.

◆ **WARNING:** Only perform such procedures as detailed in this manual. It is recommended that dealer assistance be periodically obtained on other components/systems not covered in this manual. Unless otherwise specified, engine should be turned OFF for all lubrication and maintenance procedures.

## Track

Inspect the track for wear, cuts, missing track guides and broken rods. Make any necessary replacement.

◆ **WARNING:** Do not operate a snowmobile with a cut, torn or damage track.

Lift the rear of vehicle until track is clear of the ground then support with a brace or trestle. The snowmobile should be stored in such a way that the track does not stay in contact with the cement floor or bare ground.

○ **NOTE:** The track should be rotated periodically, (every 40 days). Do not release track tension.

▼ **CAUTION:** To prevent track damage, temperature in the storage area must not exceed 38°C (100°F).

## Suspension

Remove any dirt or rust. Grease idler wheels at grease fittings. Wipe off surplus. Replace worn slider shoes.

## Skis

Wash or brush all dirt or rust accumulation from the skis and springs. Grease the ski legs at the grease fittings. Check the condition of the skis, ski runners and leaf springs. Replace if worn more than half.

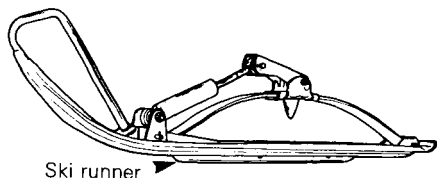

## Controls

Lubricate the steering mechanism. Inspect all components for tightness, (spring coupler bolts, steering arm locking bolts, tie rods, ball joints, etc.). Tighten if necessary. Oil metal moving joints of the brake mechanism.

◆ **WARNING:** Do not lubricate the throttle and/or brake cables and housings. Avoid getting oil on the brake pads.

Coat all electrical connections and switches with a greaseless metal protector. If unavailable, use petroleum jelly.

## Chaincase

Drain the chaincase and refill to proper level, using fresh chaincase oil. To drain, remove the chaincase cover.

## Drive Pulley

The drive pulley should be cleaned and inspected. The roller round shaft type drive pulley requires lubrication.

◆ **WARNING:** The lubrication and/or inspection of the drive pulley should be performed only by an authorized dealer.

## Fuel Tank and Carburetor(s)

Remove the cap then using a syphon, remove the gasoline from tank.

◆ **WARNING:** Gasoline is flammable and explosive under certain conditions. Always manipulate in a well ventilated area. Do not smoke or allow open flames or sparks in the vicinity.

Carburetor(s) must be dried out completely to prevent gum formation during the storage period.

Once the fuel tank is emptied, remove the float chamber drain plug(s) from carburetor(s). Drain carburetor(s) and reinstall plug(s).

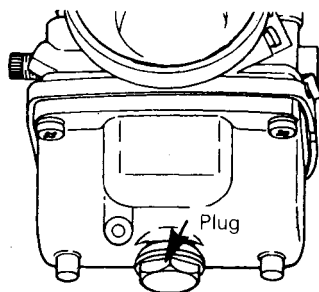

Connect fuel lines. Replace if necessary.

## Cylinder Lubrication

Engine internal parts must be lubricated to protect cylinder walls from possible rust formation during the storage period.

Use storage oil (8 oz) P/N 413 9048 00. Protection will last for the normal storage period.

Procedure:

- Insert plastic tube in spray head nozzle.
- Remove air silencer.
- Run engine at idle speed.
- Spray storage oil directly into carburetor until engine stalls. (On twin carburetor models alternate between carburetors).

▼ **CAUTION:** Only perform this procedure in a well ventilated area.

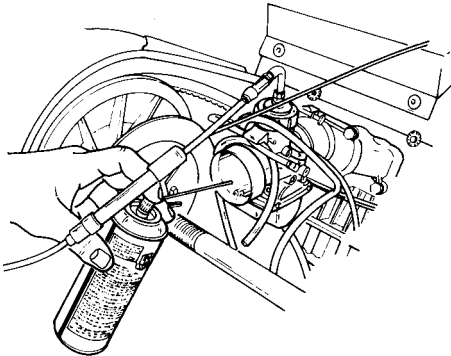

If adequate ventilation is not available.

- Remove spark plugs and spray approximately 1 ounce of storage oil in each spark plug hole and in each carburetor.

▼ **CAUTION:** Ensure cut-out switch and/or ignition key is in OFF position.

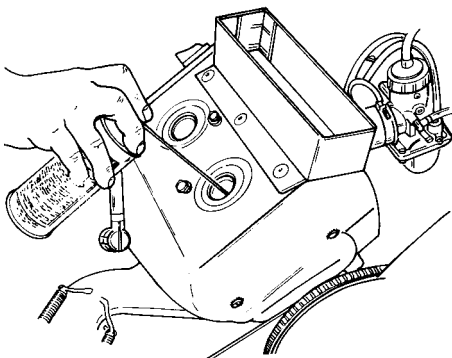

- Crank engine over several times.
- Reinstall plugs.

Do not run engine during storage period.

## Battery

Remove battery from vehicle and clean outside surface of battery with solution of baking soda and water. Remove all deposits from posts then rinse with clear tap water.

▼ **CAUTION:** Do not allow cleaning solution to enter battery interior since it will destroy the electrolyte.

Check electrolyte level. Refill if necessary with distilled water. Fully charge battery.

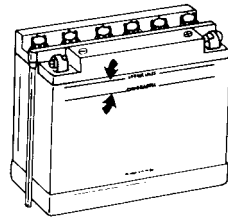

A stored battery must be recharged at least every 40 days.

▼ **CAUTION:** Prior to charging the battery, always remove it from the vehicle to prevent electrolyte spillage.

◆ **WARNING:** Gases given off by a battery being charged are highly explosive. Always charge in a well ventilated area. Keep battery away from cigarettes or open flames. Avoid skin contact with electrolyte.

Coat electrical connections and switches with a greaseless metal protector, if unavailable, use petroleum jelly. Store unit in a cool, dry place.

## Battery Removal & Installation

1. Remove and push aside the injection oil reservoir. Do not disconnect the hose. Remove the oil reservoir support.

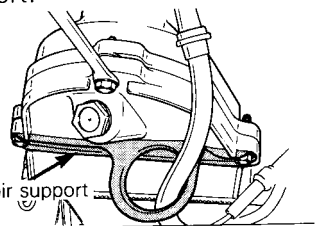

Oil reservoir support

2. Disconnect the battery cables and remove the battery retainer cover.

**▼ CAUTION:** Be careful not to ground positive terminal with the chassis.

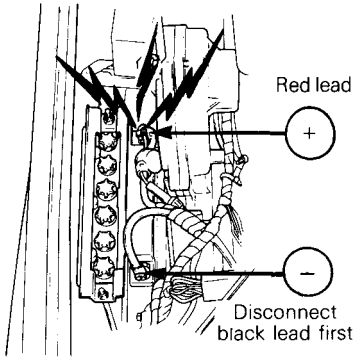

3. Remove the battery vent tube from the vent hole.

4. Lift out the battery.

**▼ CAUTION:** Be careful not to damage the oil injection pump lever when lifting out the battery.

5. Reinstall by reversing the procedure.

## Chassis

Clean the vehicle thoroughly, removing all dirt and grease accumulation.

**▼ CAUTION:** Plastic alloy components such as fuel tank, controls, windshield, etc., can be cleaned using mild detergents or isopropyl alcohol. Do not use strong soaps, degreasing solvents, abrasive cleaners, paint thinners, etc.

Clean the frame. For the aluminum portion use only "Aluminum cleaner" and follow instructions on the container.

Touch up all metal spots where paint has been scratched off. Spray all bare metal parts with metal protector. Wax the cab for better protection.

**▼ CAUTION:** Cover the snowmobile with an opaque tarpaulin. This will prevent the sun rays or grime from affecting the plastic components and vehicle finish.

## General Inspection

Check the electrical wiring and components, retighten loose connections. Check for stripped wires or damaged insulation.

Thoroughly inspect the vehicle and tighten loose bolts, nuts and linkage.

**○ NOTE:** Leave the drive belt off the pulleys for the entire storage period.

# PRE-SEASON PREPARATION

To simplify the pre-season preparation we have drawn up a small chart. The chart indicates servicing points to be performed by you and your servicing dealer. If these services are performed as suggested, your vehicle will give you many hours of fun and low cost use.

**IMPORTANT:** Observe all Warnings and Cautions mentioned throughout this manual which are pertinent to the item being checked. When component conditions seem less than satisfactory, replace with genuine Bombardier parts or suitable equivalents.

<b>PRE-SEASON PREPARATION CHART</b>	
TO BE PERFORMED BY DEALER	●
TO BE PERFORMED BY OWNER	○
Change spark plugs*	○
Check chaincase oil level	○
On vehicle equipped with fuel filter cartridge, replace cartridge	○
Check track tension and alignment	○
Lubricate suspension	○
Inspect drive belt and install	○
Check throttle cable for damage and free operation	○
Check steering alignment and ski runner condition	○
Inspect seals for possible cuts or leaks	○
Check electrical wiring (broken wire, damaged insulation)	○
Inspect condition of starting rope	○
Check tightness of all bolts, nuts and linkage	○
Refill injection oil tank	
Refill gas tank	○
Inspect brake condition and operation	●
Set engine timing	●
Check pulleys, verify components and clean. Lubricate.	●
Adjust carburetor(s)	●
Adjust oil injection pump	●



**\*NOTE:** Before installing new spark plugs, it is suggested to burn the excess storage oil by starting the engine, using the old spark plugs.



**CAUTION:** Only perform this procedure in a well ventilated area.

# TROUBLE SHOOTING

○ **NOTE:** The possible causes have been listed in an order of frequency. Therefore, items should be checked out in the same order as mentioned in the trouble shooting guide.

SYMPTOMS	POSSIBLE CAUSES	WHAT TO DO
Engine turns over but fails to start or starts with difficulty	1. No fuel to the engine	Check the tank level. Check for possible clogging of fuel line, item 4.
	2. Flooded engine	Remove wet spark plugs, turn ignition to OFF and crank engine several times. Install clean dry spark plugs. Start engine following usual starting procedure. If engine continues to flood, see your dealer.
	3. Spark plug/ ignition	Check for fouled or defective spark plug. Disconnect spark plug wire, unscrew plug and remove from cylinder head. Reconnect wire and ground exposed plug on engine cowl, <b>being careful to hold away from spark plug hole.</b> Follow engine starting procedure and check for spark. If no sparks appear, replace spark plug. If trouble persists, contact your dealer.
	4. Clogged fuel line (water or dirt)	Remove and clean the fuel filter. Change filter cartridge if necessary. Check condition and connections of fuel lines. Check the cleanliness of fuel tank.
	5. Carburetor	Contact your dealer for repair.
	6. Too much oil in fuel	Contact your dealer.
	7. Engine timing	Engine timing may be incorrect or out of adjustment. Contact your dealer.
	8. Engine compression	Running with a lean fuel mixture may produce excessive engine wear resulting in poor engine compression. If this occurs, contact your dealer at once.
Engine will not turn manually	1. Seized engine	In the case of a seized engine contact your dealer.

<b>SYMPTOMS</b>	<b>POSSIBLE CAUSES</b>	<b>WHAT TO DO</b>
Engine lacks acceleration or power	1. Fouled or defective spark plug	Check item 3 of "Engine turns over but fails to start or starts with difficulty"
	2. Clogged fuel line (water or dirt)	Check fuel line condition. (See item 4 of "Engine turns over but fails to start or starts with difficulty").
	3. Carburetors	Contact your dealer.
	4. Ignition	First check item 3 of "Engine turns over but fails to start or starts with difficulty". If the ignition system still seems faulty, contact your dealer.
	5. Engine	If unable to locate specific symptoms, contact your dealer.
Engine continually backfires	1. Faulty spark plug	Check item 3 of "Engine turns over but fails to start or starts with difficulty".
	2. Overheating	Carburetor set too lean. Contact your dealer.
	3. Engine timing incorrectly set	Contact your dealer.
Snowmobile cannot reach full speed	1. Drive Belt	Check for damaged or worn drive belt. Replace if necessary.
	2. Incorrect track adjustment	Check track tension and alignment. Readjust to specifications. (See Maintenance Section).
	3. Engine	Check item 1 to 5 of "Engine lacks acceleration or power".
	4. Pulley misaligned	Contact your dealer.

# TOOLS

As standard equipment each new snowmobile is supplied with a basic tool kit such as screwdriver, wrenches, emergency starter rope, etc...

## Standard Tools

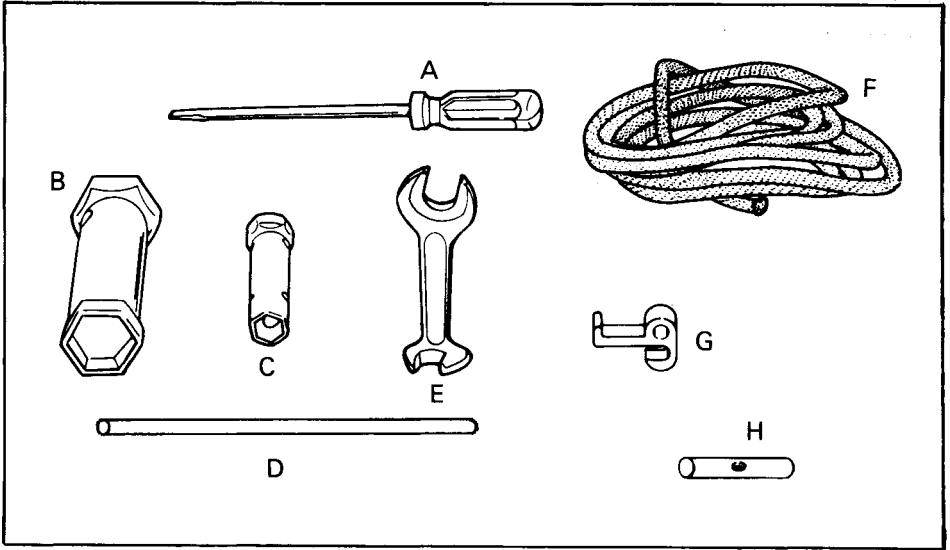

- A. Screwdriver
- B. Socket 21/26 mm
- C. Socket 10/13 mm
- D. Socket handle
- E. Angular wrench 10/13 mm
- F. Starter rope
- G. Emergency starting clip (3500 models)
- H. Emergency starter rope handle



# SPECIFICATIONS

	CITATION 3500	CITATION 4500/E	CITATION SS
<b>ENGINE</b>			
No. of cylinders	1	2	2
Bore	72 mm (2.83")	62 mm (2.44")	62 mm (2.44")
Stroke	66 mm (2.60")	61 mm (2.40")	61 mm (2.40")
Displacement	268.7 cm <sup>3</sup> (16.4 in <sup>3</sup> )	368.3 cm <sup>3</sup> (22.47 in <sup>3</sup> )	368.3 cm <sup>3</sup> (22.47 in <sup>3</sup> )
Compression ratio (corrected)	6.7:1	6.9:1	6.55:1
Maximum R.P.M.	7500	7500	8000
Carburetor type	VM 34	VM 34	2 x VM 34
Carburetor adjustment:			
— air screw	1 1/2 turn	1 1/2 turn	1 1/2 turn
— idle speed	1100-1300 RPM	1800-2000 RPM	1800-2000 RPM
Torque:			
— engine head nuts	22 N•m (16 ft-lbs)	22 N•m (16 ft-lbs)	22 N•m (16 ft-lbs)
— crankcase nuts	22 N•m (16 ft-lbs)	M6 9 N•m (6 ft-lbs) M8 22 N•m (16 ft-lbs)	M6 9 N•m (6 ft-lbs) M8 22 N•m (16 ft-lbs)
— magneto ring nut	85 N•m (62 ft-lbs)	85 N•m (62 ft-lbs)	85 N•m (62 ft-lbs)
— fan nut		65 N•m (48 ft-lbs)	65 N•m (48 ft-lbs)
— crankcase engine support nuts	22 N•m (16 ft-lbs)	38 N•m (27 ft-lbs)	38 N•m (27 ft-lbs)
— exhaust manifold bolts	22 N•m (16 ft-lbs)	22 N•m (16 ft-lbs)	22 N•m (16 ft-lbs)
— electrical starter bolts		M8 22 N•m (16 ft-lbs) M5 4 N•m (3 ft-lbs)	

<b>CHASSIS</b>			
Overall length	249 cm (98")	263 cm (103 1/2")	263 cm (103 1/2")
Overall width	92.7 cm (36 1/2")	92.7 cm (36 1/2")	92.7 cm (36 1/2")
Overall height	100.3 cm (39 1/2")	100.3 cm (39 1/2")	100.3 cm (39 1/2")
Ski stance (center to center)	82 cm (32 1/4")	82 cm (32 1/4")	82 cm (32 1/4")
Ski alignment (toe out)	3.0 mm (1/8")	3.0 mm (1/8")	3.0 mm (1/8")
Torque:			
— steering arm/ski leg bolt	43 N•m (32 ft-lbs)	38 N•m (28 ft-lbs)	43 N•m (32 ft-lbs)
— steering column/handlebar	26 N•m (19 ft-lbs)	26 N•m (19 ft-lbs)	26 N•m (19 ft-lbs)
Dry weight	156.8 kg (345 lbs)	man: 169.5 kg (373 lbs) elect: 179.5 kg (395 lbs)	172 kg (380 lbs)
Bearing area	5838 cm <sup>2</sup> (905 in <sup>2</sup> )	6225 cm <sup>2</sup> (965 in <sup>2</sup> )	6225 cm <sup>2</sup> (965 in <sup>2</sup> )
Ground pressure	2.62 kPa (.381 PSI)	man: 2.66 kPa (.386 PSI) elect: 2.82 kPa (.409 PSI)	2.71 kPa (.393 PSI)

<b>POWER TRAIN</b>			
Track:			
— width	38.1 cm (15")	38.1 cm (15")	38.1 cm (15")
— length	269.3 cm (106")	289.6 cm (114")	289.6 cm (114")
— tension	13 mm (1/2") gap between slide shoe and bottom inside of track.		
— alignment	Equal distance between edges of track guides and slider shoes.		
Standard gear ratio	15/34	16/33	17/35
Drive belt:			
— number	414 3945 00	414 3945 00	414 3758 00
— Max. width	33.3 mm (1 5/16")	33.3 mm (1 5/16")	33.3 mm (1 5/16")
— Min. width	30.1 mm (1 3/16")	30.1 mm (1 3/16")	30.1 mm (1 3/16")
Chaincase oil	200 mL (7 oz.)	200 mL (7 oz.)	200 mL (7 oz.)

<b>ELECTRICAL</b>	
Lighting system (output)	160 watts
Bulb:	
— headlamp	60/60 W
— tail/stop	5/21 W
— speedometer	5W (optional)
— tachometer	5W (optional)
Fuse:	
— ignition switch	15 A (electric model)
— main wiring	30 A (electric model)
— tachometer	.1 A (optional)
Spark plug:	
— type	N.G.K. BR8ES
— gap	.4 mm (.016")
Ignition timing:	
— timing mark (B.T.D.C.)	2.52 mm (.099") (20°)
— stroboscopic timing	6000 RPM

<b>FUEL</b>	
Gas type	Regular leaded or unleaded
Fuel tank capacity	
— SI	28.4 litres
— Imp.	6.25 gals
— U.S.	7.8 gals
Injection oil	
— type	Bombardier snowmobile oil
— tank capacity	
— SI	2.55 L
— Imp.	86 oz.
— U.S.	90 oz.

<b>BRAKE</b>	
Type	Disk
Lining minimum thickness	3 mm (1/8")
Control lever adjustment	13 mm (1/2") minimum distance from handlebar grip when fully applied.

*Bombardier Inc. reserves the right to make changes in design and specifications and/or to make additions to, or improvements in its product without imposing any obligation upon itself to install them on its products previously manufactured.*

# WIRING DIAGRAM

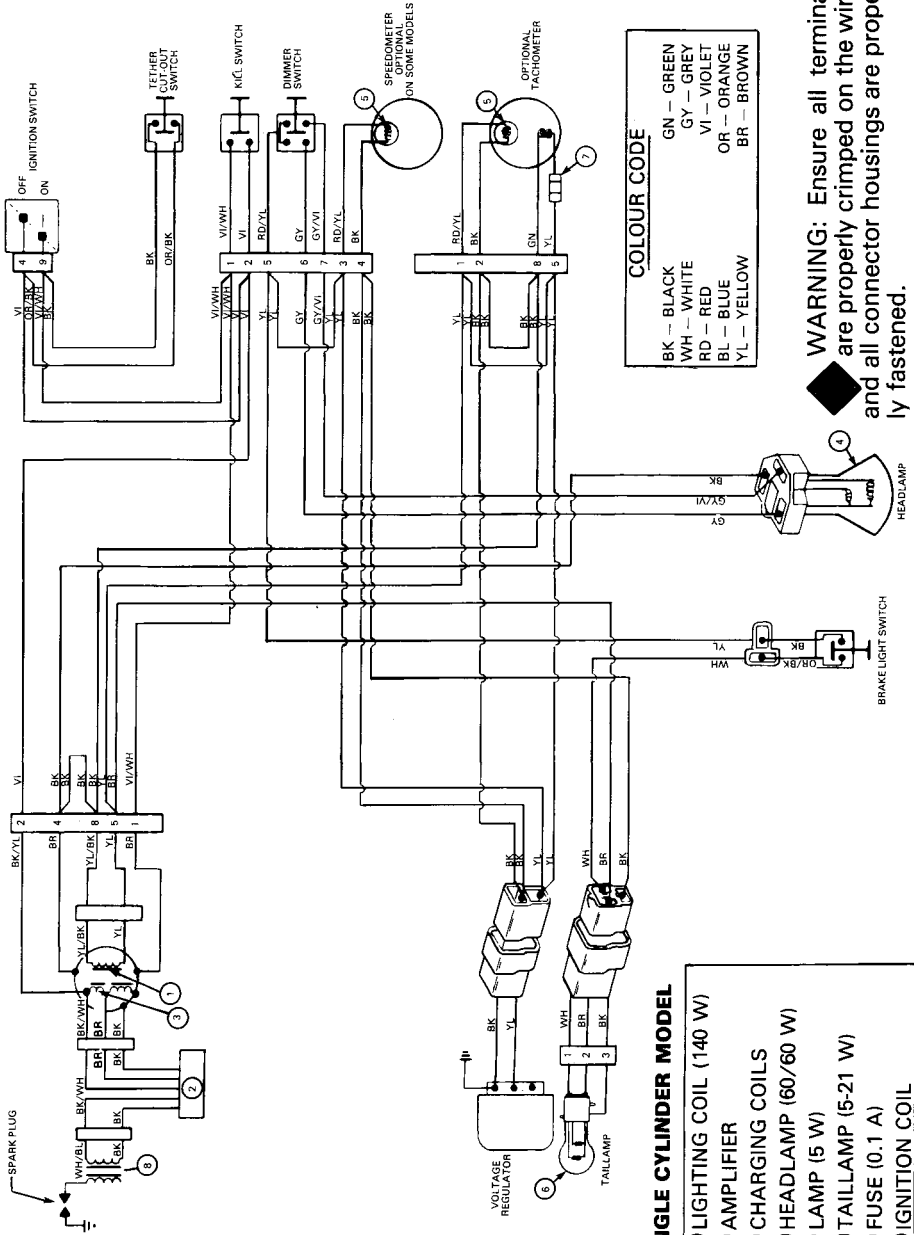

**COLOUR CODE**

BK	—	BLACK	GN	—	GREEN
WH	—	WHITE	GY	—	GREY
RD	—	RED	VI	—	VIOLET
BL	—	BLUE	OR	—	ORANGE
YL	—	YELLOW	BR	—	BROWN

**WARNING:** Ensure all terminals are properly crimped on the wires and all connector housings are properly fastened.

- SINGLE CYLINDER MODEL**
- ① LIGHTING COIL (140 W)
  - ② AMPLIFIER
  - ③ CHARGING COILS
  - ④ HEADLAMP (60/60 W)
  - ⑤ LAMP (5 W)
  - ⑥ TAILLAMP (5-21 W)
  - ⑦ FUSE (0.1 A)
  - ⑧ IGNITION COIL

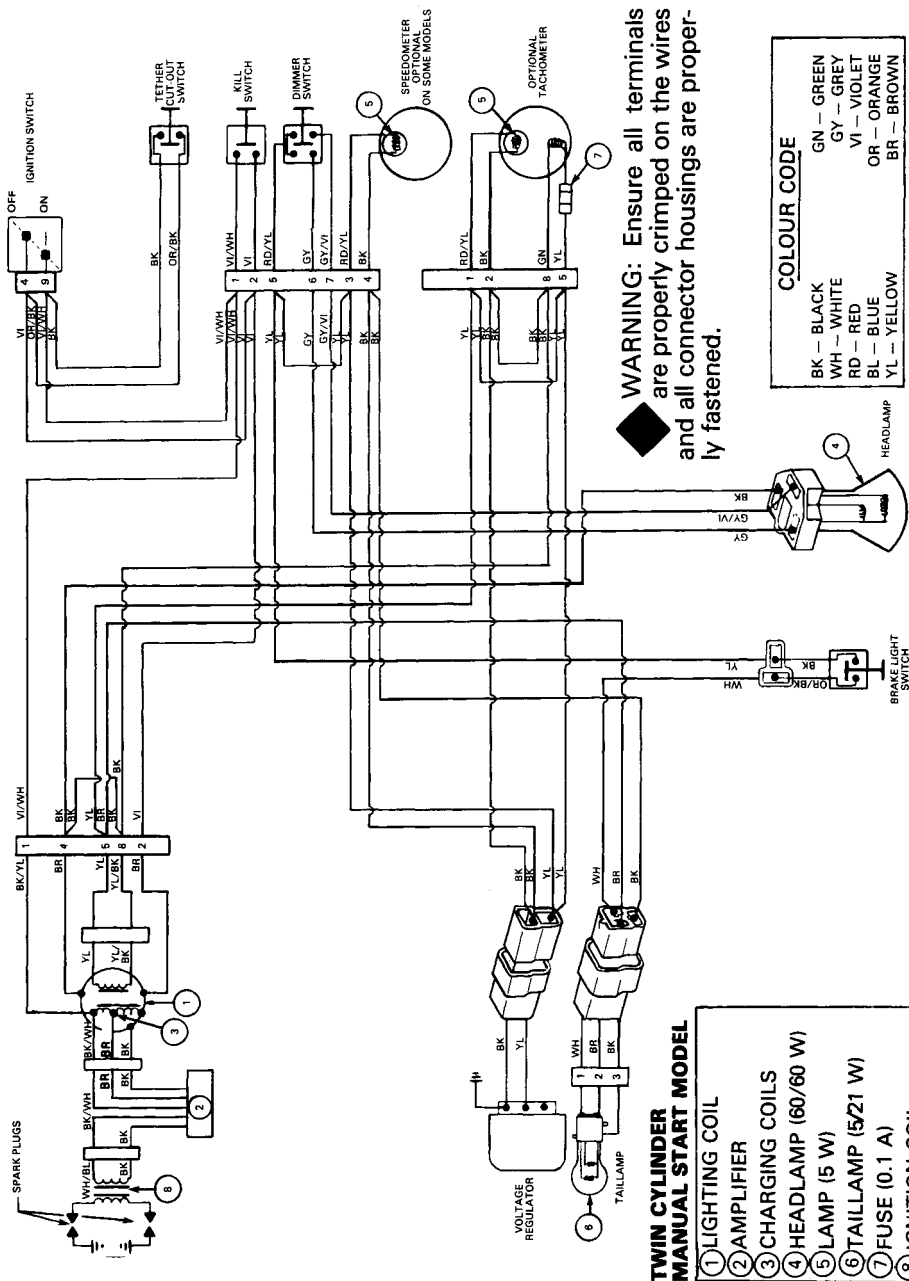

**COLOUR CODE**

BK — BLACK	GN — GREEN
WH — WHITE	GY — GREY
RD — RED	VI — VIOLET
BL — BLUE	OR — ORANGE
YL — YELLOW	BR — BROWN

- TWIN CYLINDER MANUAL START MODEL**
- ① LIGHTING COIL
  - ② AMPLIFIER
  - ③ CHARGING COILS
  - ④ HEADLAMP (60/60 W)
  - ⑤ LAMP (5 W)
  - ⑥ TAILLAMP (5/21 W)
  - ⑦ FUSE (0.1 A)
  - ⑧ IGNITION COIL

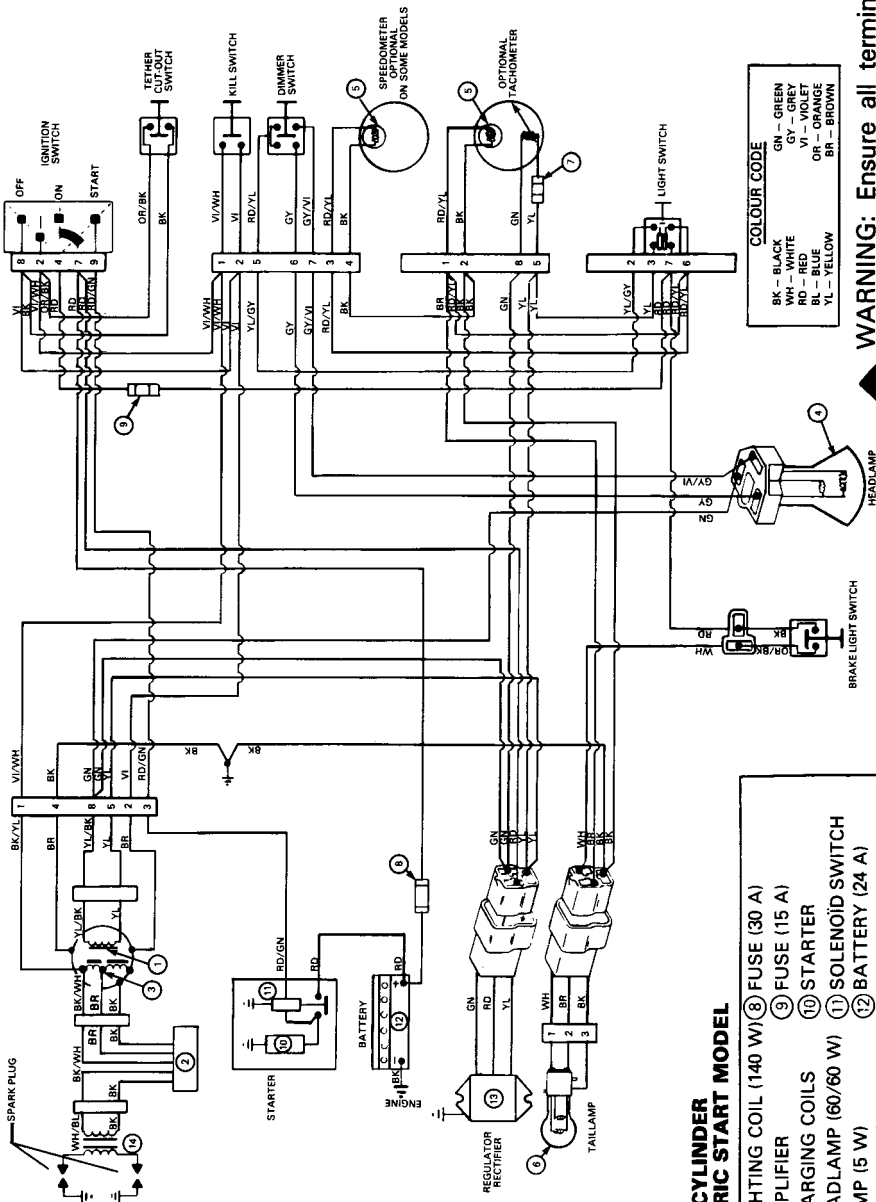

COLOUR CODE	
BK - BLACK	GN - GREEN
WH - WHITE	GY - GREY
RD - RED	VI - VIOLET
BL - BLUE	OR - ORANGE
YL - YELLOW	BR - BROWN

**WARNING:** Ensure all terminals are properly crimped on the wires and all connector housings are properly fastened.

**TWIN CYLINDER ELECTRIC START MODEL**

- ① LIGHTING COIL (140 W)
- ② AMPLIFIER
- ③ CHARGING COILS
- ④ HEADLAMP (60/60 W)
- ⑤ LAMP (5 W)
- ⑥ TAILLAMP (5/21 W)
- ⑦ FUSE (0.1 A)
- ⑧ FUSE (30 A)
- ⑨ FUSE (15 A)
- ⑩ STARTER
- ⑪ SOLENOID SWITCH
- ⑫ BATTERY (24 A)
- ⑬ REGULATOR RECTIFIER
- ⑭ IGNITION COIL

# SI\* METRIC INFORMATION GUIDE

## BASE UNITS

DESCRIPTION	UNIT	SYMBOL
length	meter	m
mass	kilogram	kg
liquid	liter	L
temperature	celsius	°C
pressure	kilopascal	kPa
torque	Newton meter	N•m
speed	kilometer per hour	km/h

---

## PREFIXES

PREFIX	SYMBOL	MEANING	VALUE
kilo	k	one thousand	1,000
centi	c	one hundredth of a	0.01
milli	m	one thousandth of a	0.001

\*THE INTERNATIONAL SYSTEM OF UNITS (SYSTEME INTERNATIONAL) ABBREVIATES "SI" IN ALL LANGUAGES.







# CHANGE OF ADDRESS AND OWNERSHIP

Any change in address or ownership should be brought to the attention of the manufacturer by completing and sending out the card supplied below.

## CHANGE OF ADDRESS



VEHICLE IDENTIFICATION NUMBER

--	--	--	--	--	--	--	--	--	--	--	--	--	--	--	--	--	--	--	--

OLD ADDRESS:

\_\_\_\_\_  
NAME

\_\_\_\_\_  
NO STREET APT.

\_\_\_\_\_  
CITY STATE ZIP / POSTAL CODE

NEW ADDRESS:

\_\_\_\_\_  
NAME

\_\_\_\_\_  
NO STREET APT.

\_\_\_\_\_  
CITY STATE ZIP / POSTAL CODE

## CHANGE OF OWNERSHIP



VEHICLE IDENTIFICATION NUMBER

--	--	--	--	--	--	--	--	--	--	--	--	--	--	--	--	--	--	--	--

The ownership of this vehicle is transferred

FROM:

\_\_\_\_\_  
NAME

\_\_\_\_\_  
NO STREET APT.

\_\_\_\_\_  
CITY STATE ZIP / POSTAL CODE

TO:

\_\_\_\_\_  
NAME

\_\_\_\_\_  
NO STREET APT.

\_\_\_\_\_  
CITY STATE ZIP / POSTAL CODE





.....

**BOMBARDIER INC.**  
ATT.: WARRANTY DEPARTMENT  
VALCOURT, QUEBEC  
CANADA, J0E 2L0

.....

**BOMBARDIER INC.**  
ATT.: WARRANTY DEPARTMENT  
VALCOURT, QUEBEC  
CANADA, J0E 2L0

.....



