

OPERATOR'S GUIDE

OUTLANDER

2003



 **WARNING**

**Read this guide thoroughly.**

**It contains important safety information.**

**Minimum recommended operator age: 16 years old.**

**Do not remove this Operator's Guide from this vehicle.**



This *Operator's Guide* utilizes the following symbols to emphasis particular information:



The Safety Alert Symbol indicates a potential personal injury hazard.



Indicates a potentially hazardous situation which, if not avoided, could result in serious injury or death.

**CAUTION:** Denotes an instruction which if not followed, may damage the ATV and/or components.

## **WARNING**

**YOUR ATV CAN BE HAZARDOUS TO OPERATE.** A collision or rollover can occur quickly, even during routine maneuvers such as turning and driving on hills or over obstacles, if you fail to take proper precautions.

For your safety, understand and follow all the warnings contained in the *Operator's Guide*, the *Safety Handbook* and the labels on your vehicle. **Failure to follow these warnings can result in SEVERE INJURY OR DEATH.**

Keep this *Operator's Guide* and the *Safety Handbook* with the vehicle at all times.

In USA, products are distributed by Bombardier Motor Corporation of America. In Canada, products are distributed by Bombardier Inc.

The following are trademarks of Bombardier Inc. or its subsidiaries:

BOMBARDIER®

ROTAX®

Outlander™

**BOMBARDIER**  
*RECREATIONAL PRODUCTS*



Printed in the EU. (Outlander ATV.fm XX)

\*™ Trademarks of Bombardier Inc. or its subsidiaries.

©2003 Bombardier Inc. All rights reserved.

---

# FOREWORD

Congratulations on your purchase of a new Bombardier® all-terrain vehicle (ATV). It is backed by the Bombardier warranty and a network of authorized Bombardier ATV dealers ready to provide the parts, service or accessories you may require.

Your dealer is committed to your satisfaction. He has taken training to perform the initial set-up and inspection of your vehicle as well as completed the final adjustment before you took possession. At delivery, your dealer would have explained the vehicle for the operation, maintenance and safety features. We trust you have taken full advantage of this! If you need more complete servicing information, please ask your dealer about the proper model-year ATV *Shop Manual*.

At delivery, you were also informed of the warranty coverage and completed the Warranty Registration Form which is to be sent to us for processing. In the near future you should be receiving a warranty card which will confirm our receipt of the registration as well as be used for warranty or recall purposes.

You are invited to contact our customer assistance center should you experience problems which cannot be resolved by an authorized Bombardier ATV dealer.

It is understood that this guide may be translated into another language. In the event of any discrepancy, the English version shall prevail.

The information and components/ system descriptions contained in this document are correct at the time of publication. Bombardier Inc. however, maintains a policy of continuous improvement of its products without imposing upon itself any obligation to install them on products previously manufactured. Due to late changes, some differences between the manufactured product and the descriptions and/or specifications in this guide may occur. Bombardier Inc. reserves the right at any time to discontinue or change specifications, designs, features, models or equipment without incurring any obligation upon itself.

The illustrations in this document show the typical construction of the different assemblies and may not reproduce the full detail or exact shape of the parts. However, they represent parts that have the same or similar function.

The use of RIGHT and LEFT indications in the text, always refers to driving position (when sitting on vehicle).

Specifications are given in the SI metric system with the SAE U.S. equivalent in parenthesis. Where precise accuracy is not required, some conversions are rounded off for easier use.

We recommend genuine Bombardier products for replacement parts and accessories. They've been especially designed for your vehicle and manufactured to meet Bombardier's demanding standards.

A *Shop Manual* can be obtained for complete service, maintenance and more repair information.

# TABLE OF CONTENTS

While reading this *Operator's Guide*, remember that:

## WARNING

Indicates a potential hazard that, if not avoided, could result in serious injury or death.

<b>FOREWORD</b> .....	<b>1</b>
<b>TABLE OF CONTENTS</b> .....	<b>2</b>
<b>NOTICE</b> .....	<b>4</b>
<b>M SPECIAL SAFETY MESSAGES</b> .....	<b>5</b>
<b>OPERATION WARNINGS</b> .....	<b>7</b>
<b>BOMBARDIER LIMITED WARRANTY</b>	
<b>NORTH AMERICA: 2003 BOMBARDIER® OUTLANDER® ATV</b> .....	<b>34</b>
<b>BOMBARDIER LIMITED WARRANTY INTERNATIONAL: 2003</b>	
<b>BOMBARDIER® OUTLANDER® ATV</b> .....	<b>37</b>
<b>FREQUENTLY ASKED QUESTIONS</b> .....	<b>40</b>
<b>EMISSION REQUIREMENTS</b> .....	<b>41</b>
<b>LOCATION OF THE IMPORTANT LABELS</b> .....	<b>42</b>
<b>HOW TO IDENTIFY YOUR ATV</b> .....	<b>47</b>
Engine and Vehicle Identification Number Location .....	47
<b>CONTROLS/INSTRUMENTS/EQUIPMENTS</b> .....	<b>48</b>
1) Throttle Lever .....	50
2) 2WD/4WD Selector .....	50
3) Brake Lever .....	50
4) Brake Lever Lock .....	51
5) Transmission Lever .....	51
6) Multi-function Switch .....	52
7) Speedometer .....	55
8) Ignition Switch .....	57
9) Fuel Tank Cap .....	57
10) Fuel Gauge .....	58
11) Fuel Valve .....	58
12) Brake Pedal .....	59
13) Footpeg .....	59
14) Access Panel .....	59
15) Rear Storage Compartment .....	60
16) Seat Latch .....	61
17) Front/Rear Cargo Rack .....	61
18) Trailer Hitch .....	61
19) Radiator Cap .....	62
20) 12-Volt Power Outlet .....	62
21) Fuses .....	62
22) Tool Box .....	63
23) Rewind Starter Handle .....	63
24) Dipstick .....	63
<b>LIQUIDS</b> .....	<b>64</b>
Fuel .....	64
Engine/Transmission Oil .....	64
Engine Coolant .....	66
Brake Fluid .....	67



Battery .....	68
<b>BREAK-IN PERIOD .....</b>	<b>69</b>
Engine .....	69
Belt .....	69
10-Hour Inspection .....	69
<b>PRE-OPERATION CHECK .....</b>	<b>70</b>
<b>OPERATING INSTRUCTIONS .....</b>	<b>71</b>
General .....	71
Initial Cold Starting .....	71
Warm Engine Starting .....	71
Emergency Manual Starting .....	72
Stopping the Engine .....	72
Shifting the Transmission .....	72
2WD/4WD Selector .....	73
<b>SPECIAL PROCEDURES .....</b>	<b>74</b>
Flooded Engine .....	74
Engine Overheat .....	74
Post-Operation Care .....	74
Turn Over .....	74
ATV Immersion .....	75
Storage and Preseason Preparation .....	75
<b>MAINTENANCE CHART .....</b>	<b>76</b>
<b>MAINTENANCE .....</b>	<b>78</b>
Engine/Transmission .....	78
Air Intake System .....	82
Electrical .....	83
Drive Train .....	84
Steering/Control Systems .....	86
Suspension .....	88
Brake .....	89
Body/Frame .....	89
<b>CARGO AND TRANSPORTATION .....</b>	<b>90</b>
Cargo .....	90
Transportation .....	91
<b>TROUBLESHOOTING .....</b>	<b>92</b>
<b>SPECIFICATIONS .....</b>	<b>95</b>
<b>SI* METRIC INFORMATION GUIDE .....</b>	<b>99</b>
<b>PRIVACY OBLIGATIONS/DISCLAIMER .....</b>	<b>100</b>
<b>CHANGE OF ADDRESS/OWNERSHIP .....</b>	<b>101</b>
<b>CHANGE OF ADDRESS/OWNERSHIP .....</b>	<b>103</b>

---

# NOTICE

This *Operator's Guide* and the *Safety Handbook* have been prepared to acquaint the owner/operator of a new vehicle with the various vehicle controls, maintenance and safe operating instructions. They are indispensable for the proper use of the product.

This *Operator's Guide* uses the following symbols.

## **WARNING**

Indicates a potentially hazardous situation which, if not avoided, could result in serious injury or death.

**CAUTION:** Denotes an instruction which, if not followed, could severely damage vehicle components.

**NOTE:** Indicates supplementary information needed to fully complete an instruction.

Although the mere reading of such information does not eliminate the hazard, the understanding and application of the information will promote the correct use of the all-terrain vehicle (ATV).

To fully appreciate the pleasures, enjoyment and excitement of using an ATV, there are some basic rules that **MUST** be observed and followed by any user.

---

## ⚠ SPECIAL SAFETY MESSAGES

### **AN ATV IS NOT A TOY AND CAN BE HAZARDOUS TO OPERATE.**

An ATV handles differently from other vehicles including motorcycles and cars. A collision or rollover can occur quickly, even during routine maneuvers such as turning and driving on hills or over obstacles, if you fail to take proper precautions.

**SEVERE INJURY OR DEATH** can result if you do not follow these instructions:

- ⚠ Read this *Operator's Guide*, the *Safety Handbook* and all on-product safety labels carefully and follow the operating procedures described.
- ⚠ Never operate an ATV without proper instruction. **Take a training course.** Beginners should receive training from a certified instructor. Contact an authorized ATV dealer to find out about the training courses nearest you or call the Specialty Vehicle Institute of America (SVIA) at 1 800 887-2887 or in Canada, the Canada Safety Council (CSC) at 1 (613) 739-1535 ext. 227.
- ⚠ Always follow this age recommendation: A child under 16 years old should never operate this ATV.
- ⚠ Never carry a passenger on an ATV.
- ⚠ Never operate an ATV on any paved surfaces, including sidewalks, driveways, parking lots and streets.
- ⚠ Never operate an ATV on any public street, road or highway, even a dirt or gravel one.
- ⚠ Never operate an ATV without wearing an approved helmet that fits properly. You should also wear eye protection (goggles or face shield), gloves, boots, long sleeved shirt or jacket, and long pants.
- ⚠ Never consume alcohol or drugs before or while operating this ATV.
- ⚠ Never operate at excessive speeds. Always go at a speed that is proper for the terrain, visibility, and operating conditions, and your experience.
- ⚠ Never attempt wheelies, jumps, or other stunts.
- ⚠ Always inspect your ATV each time you use it to make sure it is in safe operating condition. Always follow the inspection and maintenance procedures and schedules described in this *Operator's Guide* and the *Safety Handbook*.
- ⚠ Always keep both hands on the handlebars and both feet on the footpegs of the ATV during operation.
- ⚠ Always go slowly and be extra careful when operating on unfamiliar terrain. Always be alert to changing terrain conditions when operating the ATV.
- ⚠ Never operate on excessively rough, slippery or loose terrain until you have learned and practiced the skills necessary to control the ATV on such terrain. Always be especially cautious on these kinds of terrain.
- ⚠ Always follow proper procedures for turning as described in the *Safety Handbook*. Practice turning at low speeds before attempting to turn at faster speeds. Do not turn at excessive speed.
- ⚠ Never operate the ATV on hills too steep for the ATV or for your abilities. Practice on smaller hills before attempting larger hills.
- ⚠ Always follow proper procedures for climbing hills as described in the *Safety Handbook*. Check the terrain carefully before you start up any hill. Never climb hills with excessively slippery or loose surfaces. Shift your weight forward. Never open the throttle suddenly or make sudden gear changes. Never go over the top of any hill at high speed.

- ⚠ Always follow proper procedures for going down hills and for braking on hills as described in the *Safety Handbook*. Check the terrain carefully before you start down any hill. Shift your weight backward. Never go down a hill at high speed. Avoid going down a hill at an angle that would cause the vehicle to lean sharply to one side. Go straight down the hill where possible.
- ⚠ Always follow proper procedures for crossing the side of a hill as described in the *Safety Handbook*. Avoid hills with excessively slippery or loose surfaces. Shift your weight to the uphill side of the ATV. Never attempt to turn the ATV around on any hill until you have mastered the turning technique described in the *Safety Handbook* on level ground. Avoid crossing the side of a steep hill if possible.
- ⚠ Always use proper procedures if you stall or roll backwards when climbing a hill. To avoid stalling, use proper gear and maintain a steady speed when climbing a hill. If you stall or roll backwards, follow the special procedure for braking described in the *Safety Handbook*. Dismount on the uphill side or to a side if pointed straight uphill. Turn the ATV around and remount, following the procedure described in the *Safety Handbook*.
- ⚠ Always check for obstacles before operating in a new area. Never attempt to operate over large obstacles, such as large rocks or fallen trees. Always follow proper procedures when operating over obstacles as described in the *Safety Handbook*.
- ⚠ Always be careful when skidding or sliding. Learn to safely control skidding or sliding by practicing at low speeds and on level, smooth terrain. On extremely slippery surfaces, such as ice, go slowly and be very cautious in order to reduce the chance of skidding out of control.
- ⚠ Never operate an ATV in fast flowing water or in water deeper than that specified in this *Operator's Guide* and the *Safety Handbook*. Remember that wet brakes may have reduced stopping ability. Test your brakes after leaving water. If necessary, apply them several times to let friction dry out the pads.
- ⚠ Always be sure there are no obstacles or people behind you when you operate in reverse. When it is safe to proceed in reverse, go slowly.
- ⚠ Always use the size and type tires specified in this *Operator's Guide*. Always maintain proper tire pressure as described in this guide.
- ⚠ Never modify an ATV through improper installation or use of accessories.
- ⚠ Never exceed the stated load limits for an ATV. Cargo should be properly distributed and securely attached. Reduce speed and follow instructions in this *Operator's Guide* and the *Safety Handbook* for carrying cargo or pulling a trailer. Allow greater distance for braking.
- ⚠ **FOR MORE INFORMATION ABOUT ATV SAFETY**, call the Specialty Vehicle Institute of America (SVIA) at 1-800-887-2887 or in Canada, the Canada Safety Council (CSC) at 1 (613) 739-1535 ext. 227 or contact an authorized ATV dealer to find out about the training courses nearest you.

# OPERATION WARNINGS

While reading this *Operator's Guide*, remember that:

## WARNING

Indicates a potential hazard that, if not avoided, could result in serious injury or death.

The following warnings and their format have been requested by the United States Consumer Product Safety Commission and are required to be in this *Operator's Guide* and *Safety Handbook* for all ATV's.

**NOTE:** The following illustrations are general representations only. Your model may differ.

## WARNING



V00A0AQ

### **POTENTIAL HAZARD**

Operating this ATV without proper instruction.

### **WHAT CAN HAPPEN**

The risk of an accident is greatly increased if the operator does not know how to operate the ATV properly in different situations and on different types of terrain.

### **HOW TO AVOID THE HAZARD**

Beginning and inexperienced operators should complete the certified training course offered by Bombardier Inc. They should then regularly practice the skills learned in the course and the operating techniques described in this *Operator's Guide* and the *Safety Handbook*.

For more information about the training course, contact an authorized ATV dealer.





V00A01Q

**POTENTIAL HAZARD**

Failure to follow the age recommendations for this ATV.

**WHAT CAN HAPPEN**

Use by children of ATVs that are not recommended for their age can lead to severe injury or death of the child.

Even though a child may be within the age group for which an ATV is recommended, he or she may not have the skills, abilities, or judgment needed to operate the ATV safely and may be involved in a serious accident.

**HOW TO AVOID THE HAZARD**

No one under 16 should operate a Bombardier ATV.

 **WARNING**



V00A02Q

**POTENTIAL HAZARD**

Carrying a passenger on this ATV or in the rear cargo box.

**WHAT CAN HAPPEN**

Greatly reduces your ability to balance and control this ATV.  
Could cause an accident, resulting in harm to you and/or your passenger.

**HOW TO AVOID THE HAZARD**

Never carry a passenger. The long seat is to allow the operator to shift position as needed during operation. It is not for carrying passengers.

## **WARNING**



V00A03Q

### **POTENTIAL HAZARD**

Operating this ATV on paved surfaces.

### **WHAT CAN HAPPEN**

The ATV's tires are designed for off-road use only, not for use on pavement. Paved surfaces may seriously affect handling and control of the ATV, and may cause the vehicle to go out of control.

### **HOW TO AVOID THE HAZARD**

Never operate the ATV on any paved surfaces, including sidewalks, driveways, parking lots and streets.

 **WARNING**



V00A04Q

**POTENTIAL HAZARD**

Operating this ATV on public streets, roads or highways.

**WHAT CAN HAPPEN**

You can collide with another vehicle.

**HOW TO AVOID THE HAZARD**

Never operate this ATV on any public street, road or highway, even a dirt or gravel one. In many states it is illegal to operate ATVs on public streets, roads and highways.

## **WARNING**



V00A06Q

### **POTENTIAL HAZARD**

Operating this ATV without wearing an approved motorcycle helmet, eye protection and protective clothing.

### **WHAT CAN HAPPEN**

Operating without an approved motorcycle helmet increases your chances of a severe head injury or death in the event of an accident.

Operating without eye protection can result in an accident and increases your chances of a severe injury in the event of an accident.

Operating without protective clothing increases your chances of severe injury in the event of an accident.

### **HOW TO AVOID THE HAZARD**

Always wear an approved motorcycle helmet that fits properly. You should also wear:

- eye protection (goggles or face shield)
- gloves
- boots
- long sleeved shirt or jacket
- long pants.



## WARNING



V00A07Q

### **POTENTIAL HAZARD**

Operating this ATV after consuming alcohol or drugs.

### **WHAT CAN HAPPEN**

Could seriously affect your judgment.  
Could cause you to react more slowly.  
Could affect your balance and perception.  
Could result in an accident.

### **HOW TO AVOID THE HAZARD**

Never consume alcohol or drugs before or while driving this ATV.

**⚠ WARNING**

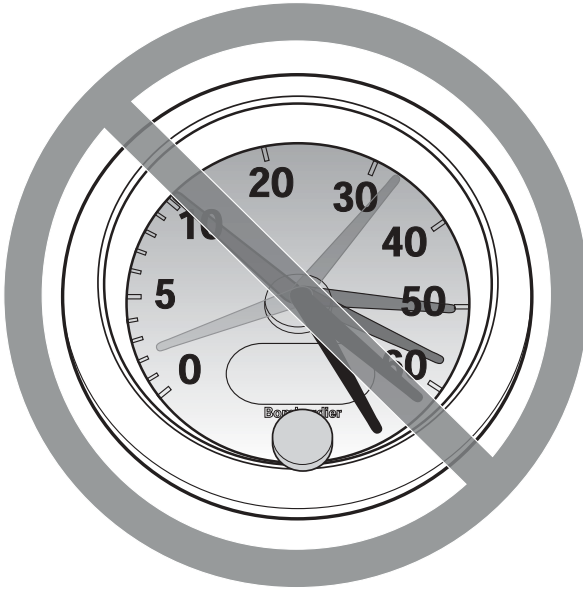

V00A08Q

**POTENTIAL HAZARD**

Operating this ATV at excessive speeds.

**WHAT CAN HAPPEN**

Increases your chances of losing control of the ATV, which can result in an accident.

**HOW TO AVOID THE HAZARD**

Always travel at a speed which is proper for the terrain, visibility and operating conditions, and your experience.

 **WARNING**

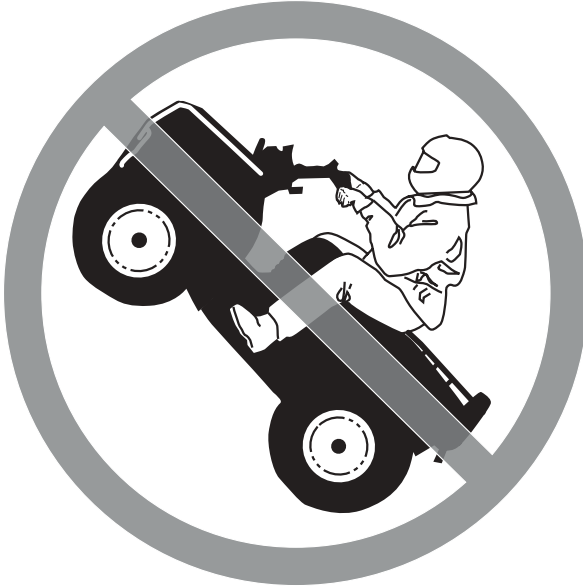

V00A09Q

**POTENTIAL HAZARD**

Attempting wheelies, jumps and other stunts.

**WHAT CAN HAPPEN**

Increases the chance of an accident, including an overturn.

**HOW TO AVOID THE HAZARD**

Never attempt stunts, such as wheelies or jumps. Do not try to show off.

## **WARNING**

### **POTENTIAL HAZARD**

Failure to inspect the ATV before operating.  
Failure to properly maintain the ATV.

### **WHAT CAN HAPPEN**

Increases the possibility of an accident or equipment damage.

### **HOW TO AVOID THE HAZARD**

Always inspect your ATV each time you use it to make sure the ATV is in safe operating condition.

Always follow the inspection and maintenance procedures and schedules described in this *Operator's Guide* and the *Safety Handbook*.

## **WARNING**



V00A0BQ

### **POTENTIAL HAZARD**

Removing hands from handlebars or feet from footpegs during operation.

### **WHAT CAN HAPPEN**

Removing even one hand or foot can reduce your ability to control the ATV or could cause you to lose your balance and fall off the ATV. If you remove a foot from the footpegs, your foot or leg may come into contact with the rear wheels, which could injure you or cause an accident.

### **HOW TO AVOID THE HAZARD**

Always keep both hands on the handlebars and both feet on the footpegs of your ATV during operation.



## **WARNING**

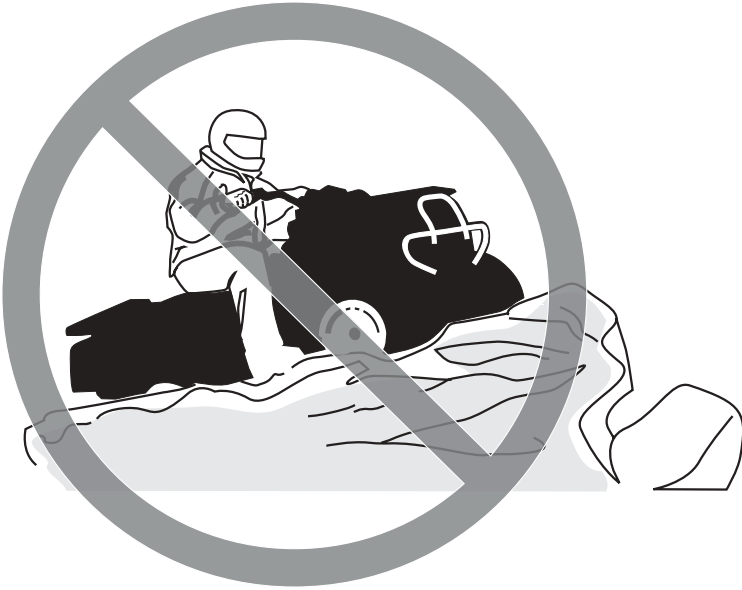

V00A0CQ

### **POTENTIAL HAZARD**

Failure to use extra care when operating this ATV on unfamiliar terrain.

### **WHAT CAN HAPPEN**

You can come upon hidden rocks, bumps, or holes, without enough time to react. Could result in the ATV overturning or going out of control.

### **HOW TO AVOID THE HAZARD**

Go slowly and be extra careful when operating on unfamiliar terrain. Always be alert to changing terrain conditions when operating the ATV.

## WARNING



V00A0DQ

### **POTENTIAL HAZARD**

Failure to use extra care when operating on excessively rough, slippery or loose terrain.

### **WHAT CAN HAPPEN**

Could cause loss of traction or vehicle control, which could result in an accident, including an overturn.

### **HOW TO AVOID THE HAZARD**

Do not operate on excessively rough, slippery or loose terrain until you have learned and practiced the skills necessary to control the ATV on such terrain. Always be especially cautious on these kinds of terrain.

**⚠ WARNING**



V00A0EQ

**POTENTIAL HAZARD**

Turning improperly.

**WHAT CAN HAPPEN**

ATV could go out of control, causing a collision or overturn.

**HOW TO AVOID THE HAZARD**

Always follow proper procedures for turning as described in the *Safety Handbook*. Practice turning at low speeds before attempting to turn at faster speeds. Do not turn at excessive speed.

**⚠ WARNING**



V00A0QQ

**POTENTIAL HAZARD**

Operating on excessively steep hills.

**WHAT CAN HAPPEN**

The vehicle can overturn more easily on extremely steep hills than on level surfaces or small hills.

**HOW TO AVOID THE HAZARD**

Never operate the ATV on hills too steep for the ATV or for your abilities. Practice on smaller hills before attempting larger hills.

## **WARNING**



V00A0FQ

### **POTENTIAL HAZARD**

Climbing hills improperly.

### **WHAT CAN HAPPEN**

Could cause loss of control or cause ATV to overturn.

### **HOW TO AVOID THE HAZARD**

Always follow proper procedures for climbing hills as described in the *Safety Handbook*.

Always check the terrain carefully before you start up any hill.

Never climb hills with excessively slippery or loose surfaces.

Shift your weight forward.

Never open the throttle suddenly or make sudden gear changes. The ATV could flip over backwards.

Never go over the top of any hill at high speed. An obstacle, a sharp drop, or another vehicle or person could be on the other side of the hill.

## WARNING



V00A0GQ

### **POTENTIAL HAZARD**

Going down a hill improperly.

### **WHAT CAN HAPPEN**

Could cause loss of control or cause ATV to overturn.

### **HOW TO AVOID THE HAZARD**

Always follow proper procedures for going down hills as described in the *Safety Handbook*.

**NOTE:** A special technique is required when braking as you go down a hill.

Always check the terrain carefully before you start down any hill.

Shift your weight backward.

Never go down a hill at high speed.

Avoid going down a hill at an angle which would cause the vehicle to lean sharply to one side. Go straight down the hill where possible.

## WARNING



V00A0HQ

### **POTENTIAL HAZARD**

Improperly crossing hills or turning on hills.

### **WHAT CAN HAPPEN**

Could cause loss of control or cause ATV to overturn.

### **HOW TO AVOID THE HAZARD**

Never attempt to turn the ATV around on any hill until you have mastered the turning technique as described in the *Safety Handbook* on level ground. Be very careful when turning on any hill.

Avoid crossing the side of a steep hill if possible.

#### **When crossing the side of a hill:**

Always follow proper procedures as described in the *Safety Handbook*.

Avoid hills with excessively slippery or loose surfaces.

Shift your weight to the uphill side of the ATV.

## **WARNING**



V00A01Q

### **POTENTIAL HAZARD**

Stalling, rolling backwards or improperly dismounting while climbing a hill.

### **WHAT CAN HAPPEN**

Could result in ATV overturning.

### **HOW TO AVOID THE HAZARD**

Use proper gear and maintain steady speed when climbing a hill.

#### **If you lose all forward speed:**

Keep weight uphill.

Apply the brakes.

Lock parking brake after you are stopped.

#### **If you begin rolling backwards:**

Keep weight uphill.

Apply the brakes gradually.

When fully stopped, lock parking brake.

Dismount on uphill side, or to a side if pointed straight uphill.

Turn the ATV around and remount, following the procedure described in the *Safety Handbook*.



## WARNING



V00A0JQ

### **POTENTIAL HAZARD**

Improperly operating over obstacles.

### **WHAT CAN HAPPEN**

Could cause loss of control or a collision. Could cause the ATV to overturn.

### **HOW TO AVOID THE HAZARD**

Before operating in a new area, check for obstacles.

Never attempt to ride over large obstacles, such as large rocks or fallen trees.

When you go over obstacles, always follow proper procedures as described in the *Safety Handbook*.

 **WARNING**



V00A0KQ

**POTENTIAL HAZARD**

Skidding or sliding improperly.

**WHAT CAN HAPPEN**

You may lose control of this ATV.

You may also regain traction unexpectedly, which may cause the ATV to overturn.

**HOW TO AVOID THE HAZARD**

Learn to safely control skidding or sliding by practicing at low speeds and on level, smooth terrain.

On extremely slippery surfaces, such as ice, go slowly and be very cautious in order to reduce the chance of skidding or sliding out of control.

## WARNING



V00A0LQ

### **POTENTIAL HAZARD**

Operating this ATV through deep or fast flowing water.

### **WHAT CAN HAPPEN**

Tires may float, causing loss of traction and loss of control, which could lead to an accident.

### **HOW TO AVOID THE HAZARD**

Never operate this ATV in fast flowing water or in water deeper than that specified in this *Operator's Guide* and the *Safety Handbook*.

Check water depth and current before you attempt to cross any water. Water should not go above footrests.

Remember that wet brakes may have reduced stopping ability. Test your brakes after leaving water. If necessary, apply them several times to let friction dry out the pads.

**⚠ WARNING**



V00A0MQ

**POTENTIAL HAZARD**

Improperly operating in reverse.

**WHAT CAN HAPPEN**

You could hit an obstacle or person behind you, resulting in serious injury.

**HOW TO AVOID THE HAZARD**

When you select reverse gear, make sure there are no obstacles or people behind you. When it is safe to proceed, go slowly.

## **WARNING**



V00A00Q

### **POTENTIAL HAZARD**

Operating this ATV with improper tires, or with improper or uneven tire pressure.

### **WHAT CAN HAPPEN**

Use of improper tires on this ATV, or operation of this ATV with improper or uneven tire pressure, may cause loss of control, and increases the risk of an accident.

### **HOW TO AVOID THE HAZARD**

Always use the size and type, tires specified in this *Operator's Guide* for this vehicle. Always maintain proper tire pressure as described in this *Operator's Guide*.

## **WARNING**



V00A0NQ

### **POTENTIAL HAZARD**

Operating this ATV with improper modifications.

### **WHAT CAN HAPPEN**

Improper installation of accessories or modification of this vehicle may cause changes in handling which in some situations could lead to an accident.

### **HOW TO AVOID THE HAZARD**

Never modify this ATV through improper installation or use of accessories. All parts and accessories added to this vehicle should be genuine Bombardier or equivalent components designed for use on this ATV and should be installed and used according to instructions. If you have questions, consult an authorized Bombardier ATV dealer.

**⚠ WARNING**



V00A0PQ

**POTENTIAL HAZARD**

Overloading this ATV or carrying or towing cargo improperly.

**WHAT CAN HAPPEN**

Could cause changes in vehicle handling which could lead to an accident.

**HOW TO AVOID THE HAZARD**

Never exceed the stated load capacity for this ATV.

Cargo should be properly distributed and securely attached.

Reduce speed when carrying cargo or pulling a trailer. Allow greater distance for braking.

Always follow the instructions in this *Operator's Guide* and the *Safety Handbook* for carrying cargo or pulling a trailer.

 **WARNING**



V03M01Q

**POTENTIAL HAZARD**

Transporting inflammable or dangerous material can lead to explosions.

**WHAT CAN HAPPEN**

This can cause serious injury or death.

**HOW TO AVOID THE HAZARD**

Never transport inflammable or dangerous material.

While reading this *Operator's Guide*, remember that:

 **WARNING**

Indicates a potential hazard that, if not avoided, could result in serious injury or death.

© 2003 Bombardier Inc. All rights reserved

® Registered trademark of Bombardier Inc. or its subsidiaries.



---

# **BOMBARDIER LIMITED WARRANTY INTERNATIONAL: 2003 BOMBARDIER® OUTLANDER® ATV**

## **1. SCOPE OF THE LIMITED WARRANTY**

BOMBARDIER INC. (hereinafter "BOMBARDIER"), warrants its 2003 BOMBARDIER OUTLANDER ATV from defects in material or workmanship for the period described below.

All genuine BOMBARDIER parts and accessories, installed by an authorized BOMBARDIER distributor/dealer (as hereinafter defined) at the time of delivery of the 2003 BOMBARDIER OUTLANDER ATV, carry the same warranty as that of the ATV.

Use of the product for racing or any other competitive activity, at any point, even by a previous owner, will render this warranty null and void.

## **2. WARRANTY COVERAGE PERIOD**

This warranty will be in effect FROM THE DATE OF DELIVERY TO THE FIRST RETAIL CONSUMER or the date the product is first put into use, whichever occurs first and for a period of: SIX (6) CONSECUTIVE MONTHS, for private use or commercial use owners <sup>(1)</sup>.

The repair or replacement of parts or the performance of service under this warranty does not extend the life of this warranty beyond its original expiration date.

## **3. CONDITIONS TO HAVE WARRANTY COVERAGE**

This warranty coverage is available only on 2003 BOMBARDIER OUTLANDER ATV purchased as new and unused by its first owner from a BOMBARDIER distributor/dealer authorized to distribute Bombardier ATV products in the country in which the sale occurred (hereinafter "BOMBARDIER ATV distributor/dealer"), and then only after the BOMBARDIER specified pre-delivery inspection process is completed and documented. Warranty coverage only becomes available upon proper registration of the product by an authorized BOMBARDIER ATV distributor/ dealer. Such limitations are necessary in order to allow BOMBARDIER to preserve both the safety of its products, and also that of its consumers and the public.

Routine maintenance outlined in the *Operator's Guide* must be timely performed in order to maintain warranty coverage. BOMBARDIER reserves the right to make warranty coverage contingent upon proof of proper maintenance.

## **4. WHAT TO DO TO OBTAIN WARRANTY COVERAGE**

The customer must notify a servicing BOMBARDIER ATV distributor/dealer within two (2) days of the appearance of a defect, and provide it with reasonable access to the product and reasonable opportunity to repair it. The customer must also present to the authorized BOMBARDIER distributor/dealer, proof of purchase of the product and must sign the repair/work order prior to starting the repair in order to validate the warranty repair. All parts replaced under this limited warranty become the property of BOMBARDIER.

1.The warranty is TWENTY FOUR (24) consecutive months if the product was sold in any of the member states of the European Union (EC directive 1999/44/EC).

The warranty period, however, is SIX (6) consecutive months if the product is used for commercial purposes.

## **5. WHAT BOMBARDIER WILL DO**

BOMBARDIER's obligations under this warranty are limited to, at its sole discretion, repairing parts found defective under normal use, maintenance and service, or replacing such parts with new genuine BOMBARDIER parts without charge for parts and labor, at any authorized BOMBARDIER distributor/dealer.

BOMBARDIER reserves the right to improve or modify products from time to time without assuming any obligation to modify products previously manufactured.

## **6. EXCLUSIONS - ARE NOT WARRANTED**

- Normal wear and tear;
- Routine maintenance items, tune ups, adjustments;
- Damage caused by failure to provide proper maintenance and/or storage, as described in the *Operator's Guide*;
- Damage resulting from removal of parts, improper repairs, service, maintenance, modifications or use of parts not manufactured or approved by BOMBARDIER or resulting from repairs done by a person that is not an authorized servicing BOMBARDIER distributor/dealer;
- Damage caused by abuse, abnormal use, neglect or operation of the product in a manner inconsistent with the recommended operation described in the *Operator's Guide*;
- Damage resulting from accident, submersion, fire, theft, vandalism or any act of God;
- Operation with fuels, oils or lubricants which are not suitable for use with the product (see the *Operator's Guide*);
- Water or snow ingestion;
- Incidental or consequential damages, or damages of any kind including without limitation towing, storage, telephone, rental, taxi, inconvenience, insurance coverage, loan payments, loss of time, loss of income.

## **7. LIMITATIONS OF LIABILITY**

THIS WARRANTY IS EXPRESSLY GIVEN AND ACCEPTED IN LIEU OF ANY AND ALL OTHER WARRANTIES, EXPRESSED OR IMPLIED, INCLUDING WITHOUT LIMITATION ANY WARRANTY OF MERCHANTABILITY OR FITNESS FOR A PARTICULAR PURPOSE. TO THE EXTENT THAT THEY CANNOT BE DISCLAIMED, THE IMPLIED WARRANTIES ARE LIMITED IN DURATION TO THE LIFE OF THE EXPRESS WARRANTY. INCIDENTAL AND CONSEQUENTIAL DAMAGES ARE EXCLUDED FROM COVERAGE UNDER THIS WARRANTY. SOME STATES/PROVINCES DO NOT ALLOW FOR THE DISCLAIMERS, LIMITATIONS AND EXCLUSIONS IDENTIFIED ABOVE, AS A RESULT, THEY MAY NOT APPLY TO YOU. THIS WARRANTY GIVES YOU SPECIFIC RIGHTS, AND YOU MAY ALSO HAVE OTHER LEGAL RIGHTS WHICH MAY VARY FROM STATE TO STATE, OR PROVINCE TO PROVINCE.

Neither the distributor, any BOMBARDIER dealer nor any other person has been authorized to make any affirmation, representation or warranty regarding the product, other than those contained in this limited warranty, and if made, shall not be enforceable against BOMBARDIER.

BOMBARDIER reserves the right to modify this warranty at any time, being understood that such modification will not alter the warranty conditions applicable to the products sold while this warranty is in effect.

## **8. TRANSFER**

If the ownership of a product is transferred during the warranty coverage period, this warranty shall also be transferred and be valid for the remaining coverage period provided that BOMBARDIER is notified of such transfer of ownership in the following way:

- a) The former owner contacts BOMBARDIER (at the phone number provided below) or an authorized BOMBARDIER ATV distributor/dealer and gives the coordinates of the new owner; or
- b) BOMBARDIER or an authorized BOMBARDIER ATV distributor/dealer receives a proof that the former owner agreed to the transfer of ownership, in addition to the coordinates of the new owner.

## **9. CONSUMER ASSISTANCE**

- a) In the event of a controversy or a dispute in connection with this BOMBARDIER LIMITED WARRANTY, BOMBARDIER suggests that you try to resolve the issue at the distributorship/dealership level. We recommend discussing the issue with the authorized dealer's service manager or owner.
- b) If further assistance is required, the distributor's service department should be contacted in order to resolve the matter.

---

## FREQUENTLY ASKED QUESTIONS

- Q: Why must my vehicle be registered with the factory? After all, I do have my original invoice as proof of when I purchased my vehicle.
- A: *Registration is very important and an authorized Bombardier ATV dealer must register your vehicle with Bombardier Inc. Make sure the registration card has been sent. All of this will allow you to:*
- a) *Have warranty work performed at any authorized Bombardier ATV dealer. Your registration card will provide the dealer with all the necessary data to complete warranty claim forms.*
  - b) *Be advised by Bombardier Inc. should there be a safety recall or a particular warranty campaign.*
  - c) *Be contacted much faster by the police, in the event that they find your vehicle subsequent to a theft.*
- Q: Why must my vehicle be registered with the governing body having jurisdiction over vehicle use?
- A: *Vehicle registration has two purposes: In many provinces or States, it is mandatory to register a vehicle in the same way as for a car. It allows the State or province to maintain records of existing vehicles. In some jurisdictions, governmental agencies use part of the registration fees for establishing and maintaining trails.*
- Q: Where can I find information on the lubrication and maintenance of my vehicle?
- A: *In the Operator's Guide provided with the vehicle at the time of delivery.*
- Q: Will the entire warranty be voided or cancelled, if I do not operate or maintain my new vehicle exactly as specified in the *Operator's Guide*?
- A: *The warranty of the new vehicle cannot be "Voided" or "Cancelled" if pre-delivered by an authorized Bombardier ATV dealer. However, if a particular failure is caused by operation or maintenance other than what is shown in the Operator's Guide, THAT failure may not be covered under warranty. This includes service work performed by the customer, oil and filter change and especially the critical adjustments such as the carburetor.*
- Q: Would you give some examples of abnormal use or strain, neglect or abuse which may affect the limited warranty coverage?
- A: *These terms are general and overlap each other in some cases. Some specific examples may include: running the engine out of oil, operating the vehicle with a broken or damaged part which causes another part to fail, and so on. If you have any specific questions on operation or maintenance, please contact an authorized Bombardier ATV dealer for advice.*
- Q: What costs are my responsibility during the warranty period?
- A: *The customer's responsibility includes all costs of normal maintenance services, non-warranty repairs, accidents and collision damage, as well as oils, and spark plugs, and incidental or consequential damages costs as explained in the warranty.*

- Q: Are "Genuine" Bombardier replacement parts used in warranty repairs also covered by the limited warranty coverage?  
 A: *Yes. When installed by an authorized Bombardier ATV dealer, any "Genuine" Bombardier part used in warranty repairs assumes the remaining warranty that exists on the vehicle.*
- Q: If I sell my vehicle within the warranty period, will the new owner qualify for the balance of the limited warranty coverage?  
 A: *Yes, provided the re-sale has been registered with the manufacturer.*
- Q: How can I receive the best owner assistance?  
 A: *The satisfaction, safety and goodwill of the owners of Bombardier products are of primary concern to your ATV dealer and Bombardier Inc. Normally, any problems that arise in connection with the sales transaction or the operation of your vehicle will be handled by your Dealer's Sales or Service Departments. It is recognized, however, that despite the best intentions of everyone concerned, misunderstandings will sometimes occur. Frequently, complaints are the result of a breakdown in communications and can quickly be resolved by a member of the dealership management. If the problem already has been reviewed with the Sales Manager or Service Manager, contact the Dealer Principal himself or the General Manager.*

**We are always pleased to receive your comments on the Bombardier ATV.**

---

## **EMISSION REQUIREMENTS**

The California Air Resources Board (CARB) requires that your ATV complies with applicable exhaust emissions standards during its useful life, when operated and maintained according to the instructions supplied.

A non-compliance Red Label (as well as a Green Label) is obtained annually during California Vehicle registration. The appropriate label is denoted by the vehicle identification number (in the 8<sup>th</sup> character detailed herein).

VEHICLE CATEGORY	VIN 8 <sup>th</sup> CHARACTER
Non-complying Red Label	Must denote a C or 3
Complying Green Label	Any alphanumeric designation other than a C or 3

# LOCATION OF THE IMPORTANT LABELS

The following labels are on your ATV. If missing or damaged, they can be replaced free of charge. See an authorized Bombardier ATV dealer.

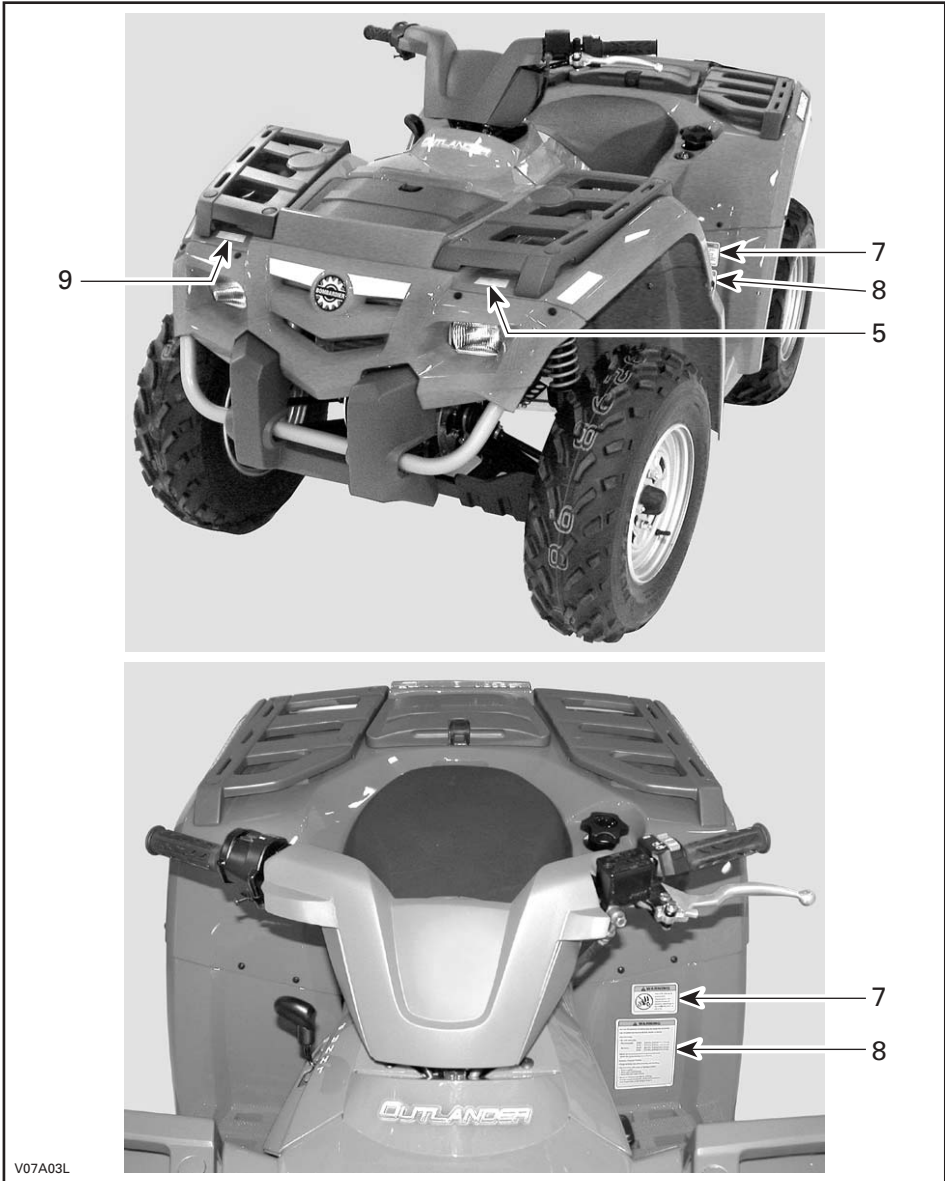

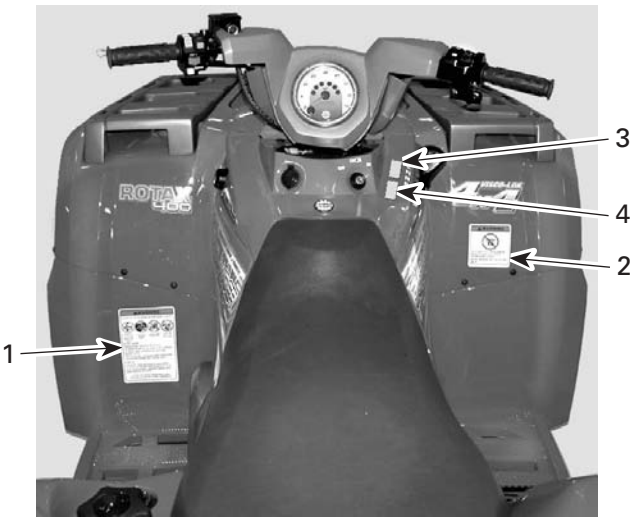





V07A06L

### Label 1

**WARNING**  
Improper ATV use can result in SEVERE injury or DEATH.

			
ALWAYS USE AN APPROVED HELMET AND PROTECTIVE GEAR	NEVER USE ON PUBLIC ROADS	NEVER CARRY PASSENGERS	NEVER USE WITH DRUGS OR ALCOHOL

**NEVER** operate:

- without proper training or instructions.
- at speeds too fast for your skills or the conditions.
- on public roads - a collision can occur with another vehicle.
- with a passenger - passengers affect balance and steering and increase risk of losing control.

**ALWAYS:**

- use proper riding techniques to avoid vehicle overturns on hills and rough terrain and in turns.
- avoid paved surfaces - pavement may seriously affect handling and control.

LOCATE AND READ OPERATOR'S GUIDE.  
FOLLOW ALL INSTRUCTIONS & WARNINGS.

V01M01Z XXX XXX XXX

### Label 2

**WARNING**

**UNDER 16**

Operating this ATV if you are under the age of 16 increases your chance of SEVERE INJURY or DEATH.  
**NEVER** operate this ATV if you are under age 16.

V01M02Z 704 900 011

### Label 3

**CAUTION**

- **ATV MUST** be stopped before shifting lever.
- **Always** apply foot brake to shift from Park(P) and Neutral(N).

704 900 470

V07M06Y

### Label 4

**CAUTION**

**ATV MUST** be stopped to engage or disengage 4WD switch  
**Mechanical damage may occur if switch is engaged or disengaged while driving**

704 900 471

V07M07Y

### Label 5

**WARNING**

**NEVER sit here**

704 900 483

V07M05Y



**Label 6**

 **WARNING**

Improper loading of a trailer may cause loss of vehicle control.

- Maximum towing weight: 500 kg (1100 lb).
- Maximum tongue weight: 14 kg (30 lb).

704 900 009

V01M06Z

**Label 7**

 **WARNING**



**NEVER** ride as a passenger. Passengers can cause a loss of control, resulting in **SEVERE INJURY** or **DEATH**.

704 900 005

V01M07Z

**Label 8**

 **WARNING**

Improper tire pressure or overloading can cause loss of control.  
Loss of control can result in **SEVERE INJURY** or **DEATH**.

**TIRE PRESSURE**

- Set with tires cold:
  - Recommended: **FRONT:** 27.6 kPa, (0.28 kgf/cm<sup>2</sup>), 4.0 psi.  
**REAR:** 31.0 kPa, (0.32 kgf/cm<sup>2</sup>), 4.5 psi.
  - Minimum: **FRONT:** 24.1 kPa, (0.25 kgf/cm<sup>2</sup>), 3.5 psi.  
**REAR:** 27.6 kPa, (0.28 kgf/cm<sup>2</sup>), 4.0 psi.
- Never set tire pressure below minimum. It could cause the tire to dislodge from the rim.

**LOADING / TRAILER TOWING**

- Cargo or trailer can affect stability and handling.
- When loading cargo or towing a trailer:
  - Reduce speed.
  - Allow more room to stop.
  - Avoid hills and rough terrain.
- Maximum Vehicle Load: 220 kg (485 lb.). Includes weight of operator, cargo and accessories (and if applicable, trailer tongue weight).

704 900 472

V07M03Y

**Label 9**

**CAUTION**

**MAXIMUM FRONT LOAD: 40 kg (90 lb)**

704 900 433

V07M04Y

**Label 10**

**CAUTION**

**MAXIMUM REAR LOAD: 40 kg (90 lb)**  
Includes trailer tongue weight and storage tray load: 10 kg (22lb)

704 900 432

V07M02Y



# HOW TO IDENTIFY YOUR ATV

The main components of your vehicle (engine and frame) are identified by different serial numbers. It may sometimes become necessary to locate these numbers for warranty purposes or to trace your vehicle in the event of loss. These numbers are required by the authorized Bombardier ATV dealer to complete warranty claims properly. No warranty will be allowed by Bombardier Inc. if the engine identification number (EIN) or vehicle identification number (VIN) is removed or mutilated in any way. We strongly recommend that you take note of all the serial numbers on your vehicle and supply them to your insurance company.

## Engine and Vehicle Identification Number Location

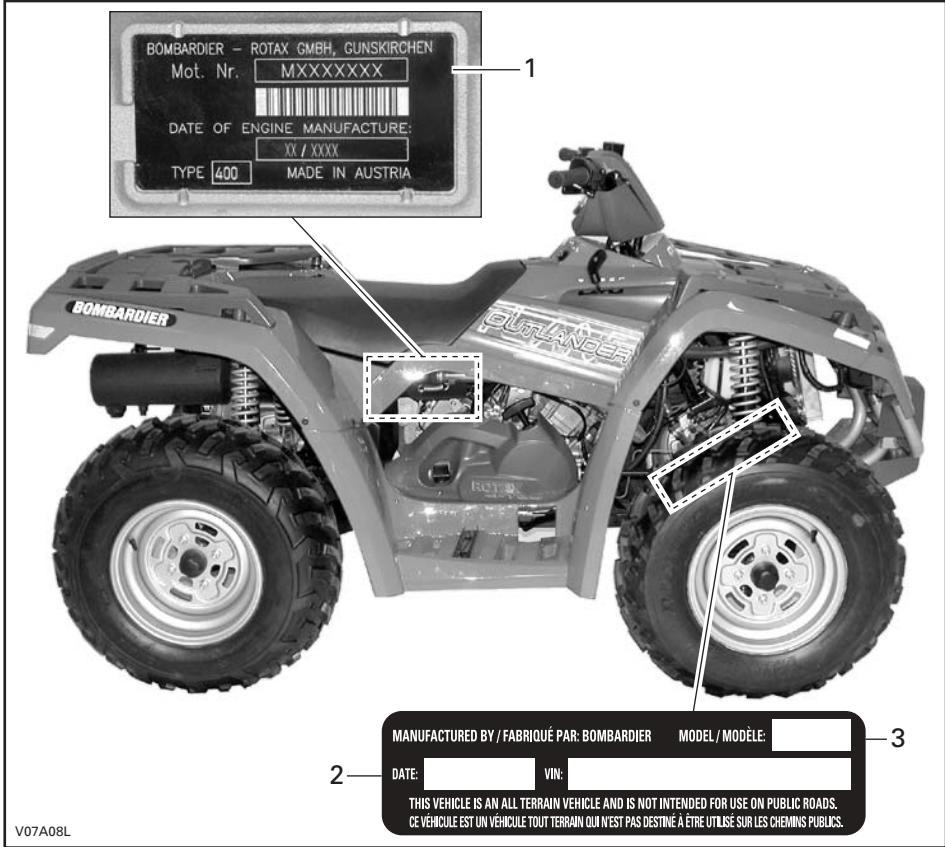

1. EIN (Engine Identification Number)
2. VIN (Vehicle Identification Number)
3. Model

# CONTROLS/INSTRUMENTS/EQUIPMENTS

NOTE: Some controls/instruments/equipments are optional.

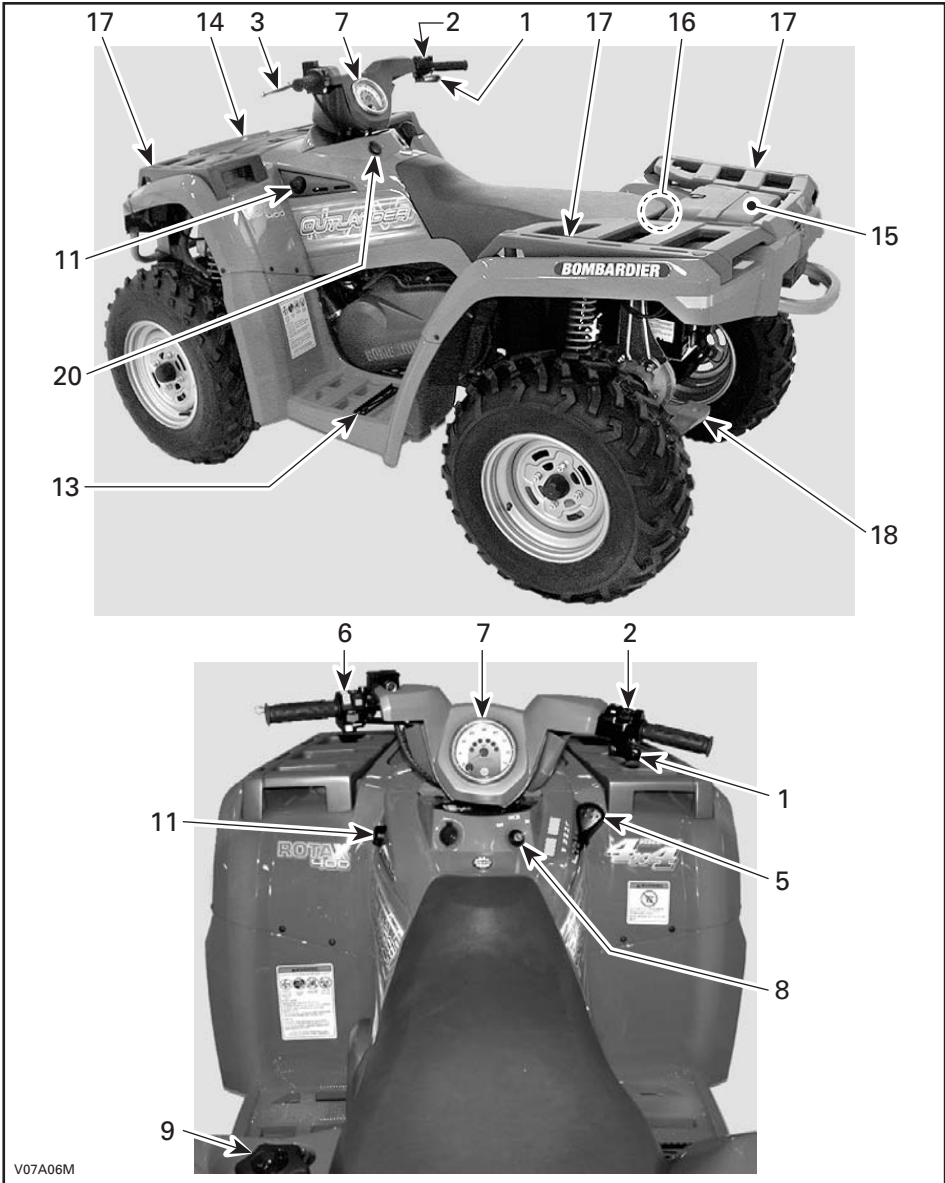

V07A06M

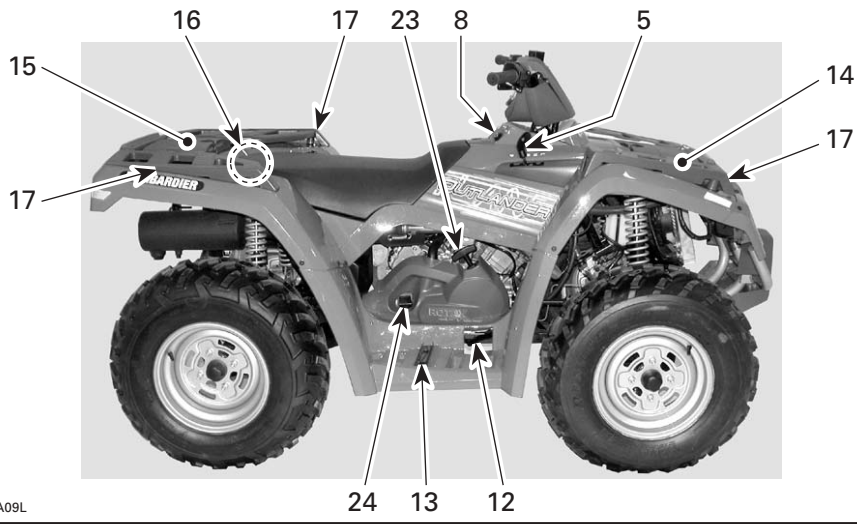
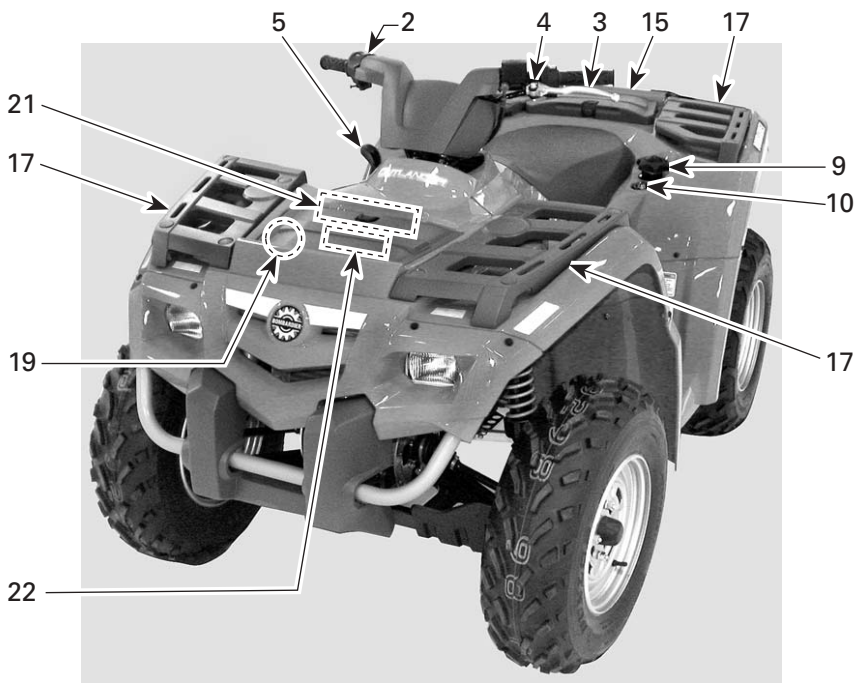

V07A09L

While reading this *Operator's Guide*, remember that:

## **WARNING**

Indicates a potential hazard that, if not avoided, could result in serious injury or death.

**NOTE:** This section gives basic functions of the various controls of your ATV. For more details of how to operate one control in conjunction with some others, refer to **OPERATING INSTRUCTIONS** in this *Operator's Guide* and *Safety Handbook*.

### **1) Throttle Lever**

Located on the right side of handlebar. When pushed, it increases the engine speed that allows the engagement of the transmission on the selected gear.

When released, the engine speed should return automatically to idle and the vehicle will gradually slow down.

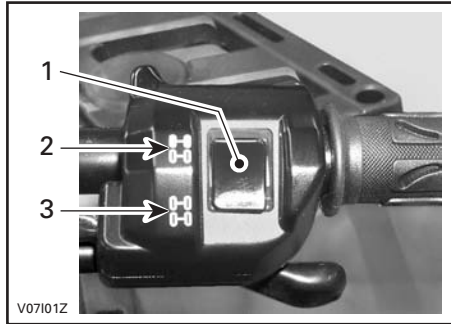

1. Selector
2. 2WD position
3. 4WD position

### **3) Brake Lever**

Located on the left side of handlebar. When the brake lever is compressed, the front and rear brakes are applied. When released, the brake lever should automatically return to its original position. Braking effect is proportional to the force applied on the lever and to the type and condition of the terrain.

**NOTE:** As on other wheeled vehicles, the vehicle weight is transferred to the front wheels when braking. To obtain greater stopping efficiency, the brake system distributes more braking force to the front wheels. This will affect vehicle handling and steering control when braking vigorously. Take it into account when braking.

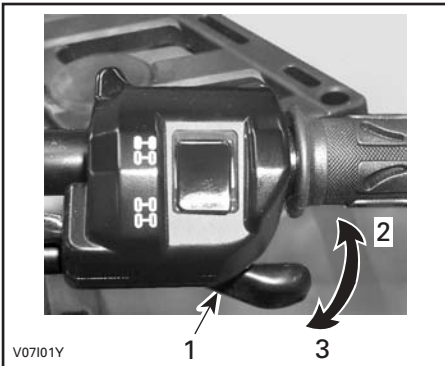

1. Throttle lever
2. To accelerate
3. To decelerate

### **2) 2WD/4WD Selector**

Located on the top of throttle handle, this selector allows to choose between 2WD and 4WD.

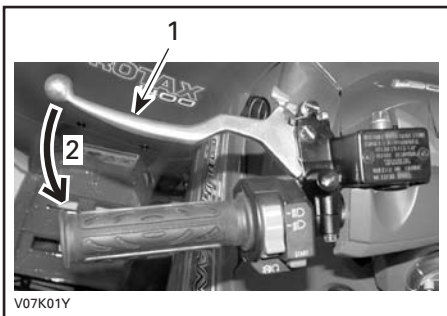

V07K01Y

1. Brake lever
2. To apply brakes

#### 4) Brake Lever Lock

Located on left side of handlebar on the brake lever. When applied, it prevents the vehicle from moving. Useful when the brake needs to be locked for example such as doing a K-turn.

### WARNING

Always use the brake lever lock **and** engage the PARK position on the transmission lever when the vehicle is not in operation.

### WARNING

Make sure brake lever lock is fully disengaged before operating the ATV. When you ride the vehicle, brake that are caused to drag by a continuous pressure on the lever may cause damage to the brake system and cause loss of braking capacity and/or fire.

**To engage mechanism:** Squeeze brake lever and maintain while moving lever lock with a finger. Brake lever is now compressed and applying all brakes.

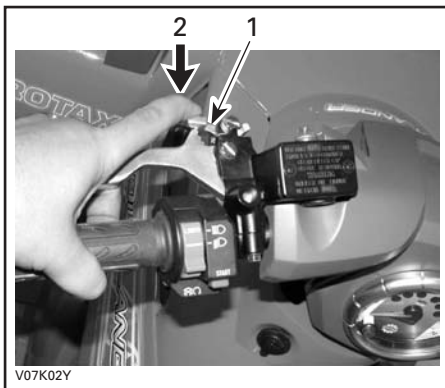

V07K02Y

1. Brake lever lock
2. Press to apply parking brakes

**To release mechanism:** Squeeze brake lever. Lever lock should automatically return to its original position. Brake lever should return to rest position. Always release brake lever lock before riding.

#### 5) Transmission Lever

Located on the right side of vehicle. A 5-position lever: P, R, N, H and L.



V07D01Y

To change the transmission position, completely stop vehicle then move lever to the desired position while moving lever forward. Do not force lever. If unable to shift, gently apply throttle and release it immediately then, wait engine RPM returns to stable idle and try again.



### SHIFT PATTERN

**CAUTION:** Always completely stop the vehicle and apply the brake prior to moving the transmission lever.

#### P: Park

This position locks the transmission to help prevent vehicle movement. Always use when the vehicle is not in operation. In some circumstances, it may be necessary to rock the vehicle back and forth to move the gears in the transmission to allow the park to be engaged.

#### R: Reverse

This allows the vehicle to go backward. The vehicle speed is limited.

## WARNING

Before moving vehicle in reverse, ensure the path behind is clear of obstacles or bystanders. Remain seated.

#### N: Neutral

This position disengages the transmission to allow manual vehicle movement or towing.

#### H: High gear

This selects the high speed range of the transmission in the gear box. It is the normal driving speed range. It allows the vehicle to reach its maximum speed.

#### L: Low gear

This selects the low speed range of the transmission in the gear box. It is the working position. It allows the vehicle to move slowly with the maximum traction and power.

**NOTE:** Use the low speed range to pull any load or to climb a steep incline.

## 6) Multi-function Switch

The multi-function switch is located on the left side of handlebar.

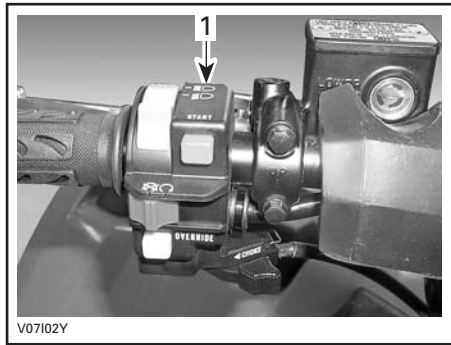

### 1. Multi-function switch

The controls located on this multi-function switch are:

#### Headlight Switch

Located on the top of multi-function switch. Place headlight switch to LO for the low beam and taillight. Place headlight switch to HI for the high beam and taillight.



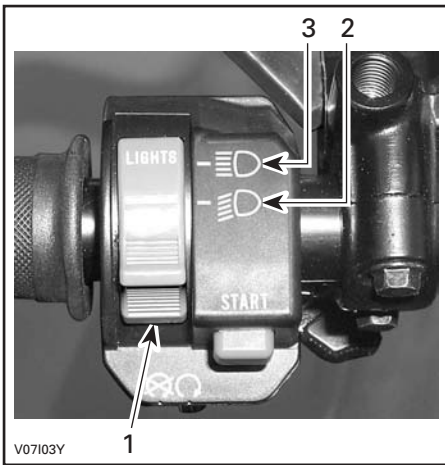

1. Headlight switch
2. Low beam position
3. High beam position

**NOTE:** Place ignition switch to ON “without light” position to close the headlight.



**ON POSITION “WITHOUT LIGHT”**

## Engine Stop Switch

Located at the middle of multi-function switch. The engine will turn over but will not start if the engine stop switch is turned to OFF position.

This switch can be used to stop engine and as an emergency control.

**NOTE:** While engine can be stopped by turning ignition key OFF, we recommend the engine be stopped by the engine stop switch.



1. Engine stop switch

To stop engine, fully release throttle lever then use the engine stop switch.

## Start Button

Located above engine stop switch.

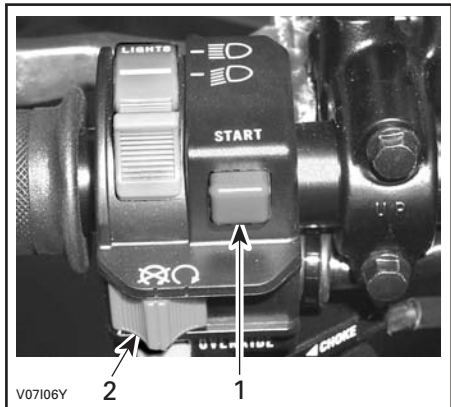

1. Start button
2. Engine stop switch

To start engine, place the engine stop switch to RUN.

Press and hold the start button. Release immediately after engine is started.

## Override Button

Located below engine stop switch.

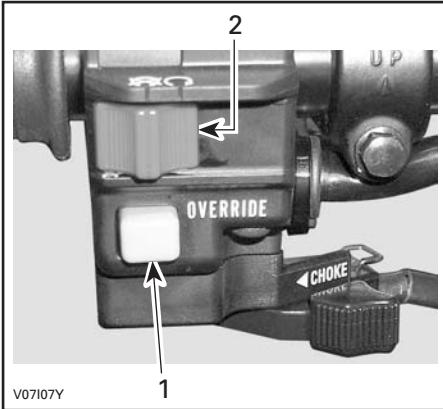

1. Override button
2. Engine stop switch

This button is used to override the reverse speed limiter system and while power backing up. To do this, press the override button.

### **WARNING**

Never activate the override button while throttle is open as loss of control may result, causing severe personal injury or death.

## Choke Lever

Located at bottom of multi-function switch. This device features a variable lever to ease cold start.

Position OFF is for normal use with a warm engine.



### *CHOKE LEVER IN THE OFF POSITION*

The full choke position is used for lower engine temperature.



### *CHOKE LEVER IN THE FULL CHOKE POSITION*

The other positions between OFF and FULL position, will be use depending on the engine temperature.

## 7) Speedometer

This vehicle is equipped with an electronic speedometer. It indicates the speed of vehicle either in MPH or km/h.

The speedometer is located at the middle of cluster and it backlit every time the ignition switch is turned ON,

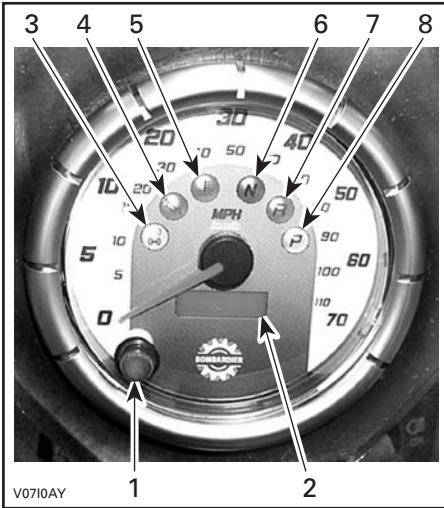

1. Display selector button
2. Display
3. 4WD indicator lamp
4. Oil pressure indicator lamp
5. Engine temperature indicator lamp
6. Neutral position indicator lamp
7. Reverse position indicator lamp
8. Park position indicator lamp

### Change from One Unit to the Other

The speedometer is factory pre-set in miles but it is possible to change it to kilometer reading.

**NOTE:** The unit modification is applied to the speedometer, odometer and trip meter.

Turn ignition switch OFF and open the access panel. Cut locking ties retaining the change wire to the rectifier harness.

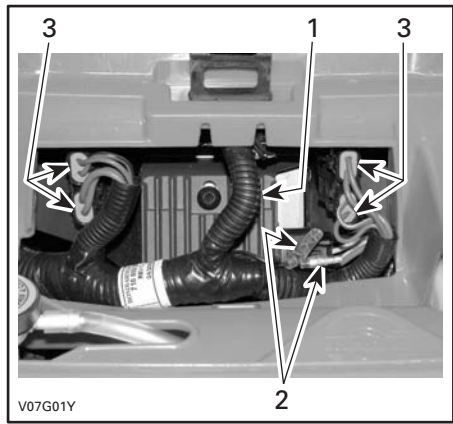

1. Rectifier harness
2. Change wire connectors
3. Fuse holders

Plug connectors to change units from miles to kilometers. Unplug to return to miles reading.

Fix the change wires to the harness with new locking ties.

### Display Selector Button

The odometer always appears when turning the ignition switch ON (either ON position). To change the display to the trip meter, depress the display selector button.

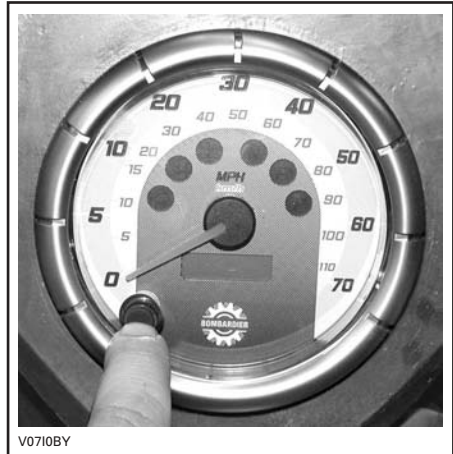

Depressing display selector button again will change display for the resettable hourmeter. Push display selector button again to return to odometer.

## Odometer

Odometer records the total distance travelled either in miles or kilometers.

## Trip Meter

The trip meter records distance travelled since it has been reset. Distance travelled is displayed either in miles or kilometers.

It can be used to establish a fuel tank range or distance between 2 way points for instance.

Push and HOLD display selection button for 2 seconds to reset the trip meter.

## Hourmeter

The hourmeter records engine running time in hours and minutes since it has been reset.

## Indicator Lamps

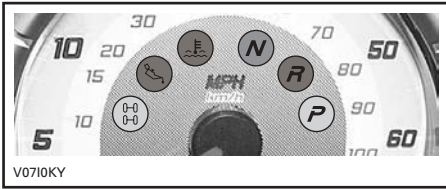

### 4-Wheel Drive (AMBER)

When this indicator light is ON, it indicates the 4WD system is activated.



### Oil Pressure (RED)

When this indicator light is ON, it indicates a low oil pressure condition of the engine.

**CAUTION:** If the light does not turn off right after engine starting, stop engine. See an authorized Bombardier ATV dealer. Do not use the vehicle until repaired.



### Engine Temperature (RED)

When this indicator light is ON, it indicates the engine is overheating.

If engine overheats, refer to ENGINE OVERHEAT in SPECIAL PROCEDURES.

**CAUTION:** If the light does not turn off right after engine starting, stop engine. See an authorized Bombardier ATV dealer. Do not use the vehicle until repaired.



### Neutral (GREEN)

When lit, it indicates the transmission is in neutral position.



### Reverse (RED)

When lit, it indicates the transmission is in reverse position.



### Park (AMBER)

When lit, it indicates the transmission is in park position.

## 8) Ignition Switch

Located on the console.

Key-operated, 3-position switch: OFF, ON with lights and ON without lights.

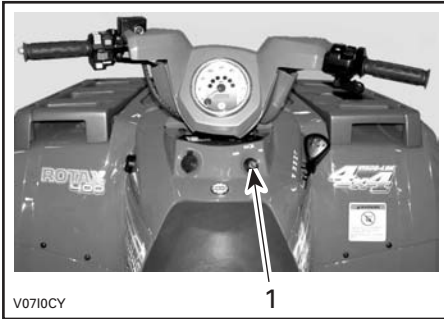

1. Ignition switch

Insert key in switch and turn to the desired position. To remove key, turn key to OFF then pull it out.

The ON with lights position, turns on all lights with either the engine running or not. Remember that having the lights on without the engine running discharges the battery. Always turn ignition to OFF after engine has been stopped.

**NOTE:** While engine can be stopped by turning ignition key OFF, we recommend the engine be stopped by the engine stop switch.

## 9) Fuel Tank Cap

The fuel tank cap is located on the left side of the rear fender.

**CAUTION:** Never place anything over fuel tank cap because the vent hole on the top of fuel tank cap can be blocked and the engine could misfire.

Unscrew counterclockwise and remove cap to allow fuel tank filling then fully tighten clockwise.

### **WARNING**

Always stop engine before refueling. Open cap slowly. If a differential pressure condition is noticed (whistling sound heard when loosening fuel tank cap) have vehicle inspected and/or repaired before further operation. Fuel is flammable and explosive under certain conditions. Never use an open flame to check fuel level. Never smoke or allow open flame or spark in vicinity. Always work in a well-ventilated area. Never top up the fuel tank before placing the vehicle in a warm area. As temperature increases, fuel expands and may overflow. Always wipe off any fuel spillage from the vehicle.



1. Fuel tank cap  
2. Seat

## 10) Fuel Gauge

Located on the left side of the rear fender near fuel tank cap, the gauge shows an approximate amount of the fuel in tank.

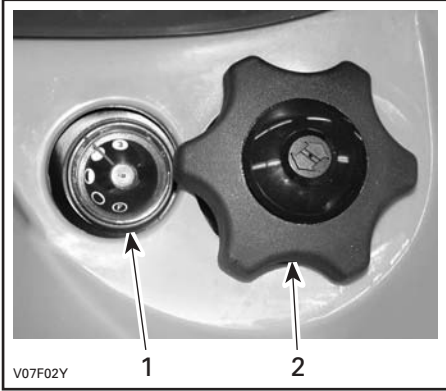

1. Fuel gauge
2. Fuel tank cap

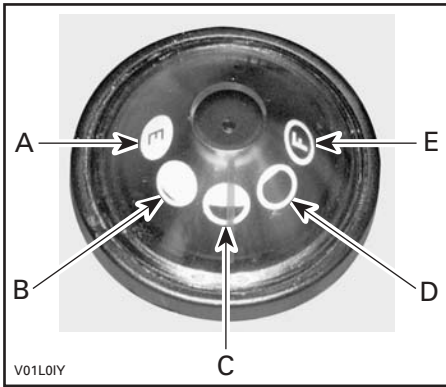

- A. Empty
- B. 1/4
- C. 1/2
- D. 3/4
- E. Full

## 11) Fuel Valve

Located on left side panel under console. 3-position rotary valve: OFF, ON, RES. Rotate the knob to align its pointer with ON, OFF or RES.

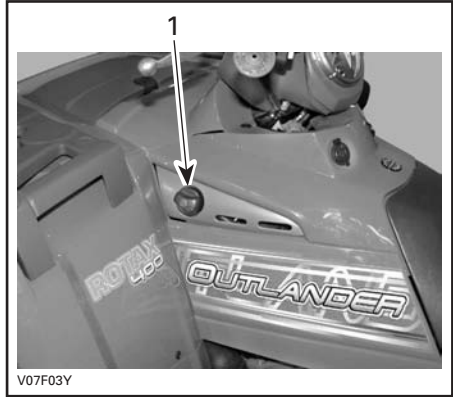

1. Align this pointer toward the desired position

### OFF

Stops fuel supply to carburetor.

**CAUTION:** Turn valve to OFF position when ATV is not being operated or when transporting.

### ON

Allows fuel to flow to carburetor. This is the normal position for operation of the vehicle.

### RES (reserve)

When fuel is exhausted in the fuel tank when in the ON position, an emergency supply of fuel is available by turning the knob to RES. The reserve contains approximately 12% of the fuel tank capacity. Use only this position when the ON supply is empty.

When down to the reserve, refuel as soon as possible. Ensure to turn the valve back to the ON position after refuelling.

**CAUTION:** Improper opening of fuel valve will restrict the flow of fuel. Make sure valve is fully opened while running.

## 12) Brake Pedal

Located on the right footrest. When pressed down, the rear brake is applied. When released, the brake pedal should return to its original position. Braking effect is proportional to the force applied on the pedal and to the type and condition of the terrain.

**NOTE:** The brake will have also an effect on front wheels through the drive train.

The brake pedal applies the rear brake only. Should the main brake system fail, the rear brake can be activated by depressing the brake pedal.

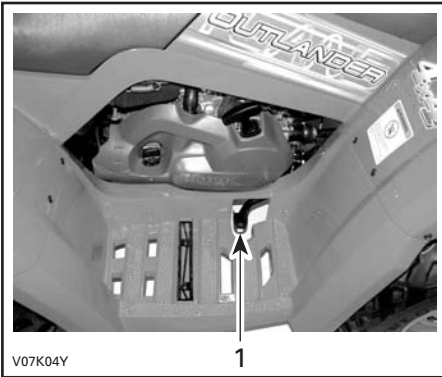

1. Brake pedal

## 13) Footpeg

Located on footrest. Use this area to maintain your feet stable.

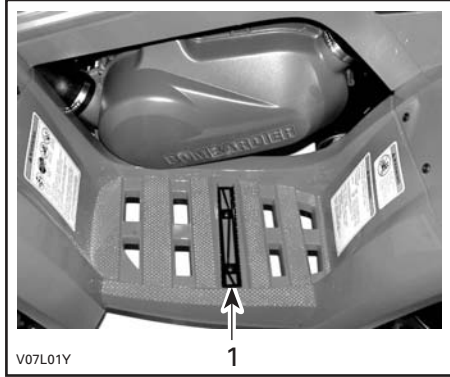

1. Footpeg

## 14) Access Panel

The access panel is located on the front fender, between front racks. To open the panel, unlatch, lift then remove it completely.

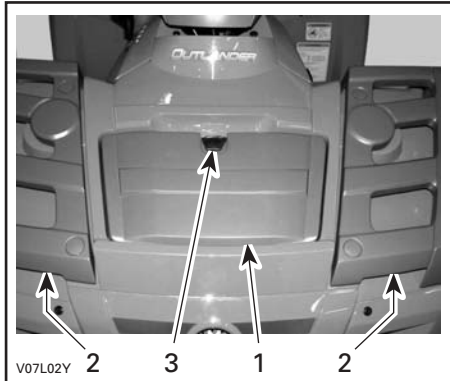

1. Access panel  
2. Front racks  
3. Latch



This panel allows an easier access to the service compartment. The service compartment contains different maintenance items like rear brake fluid reservoir, radiator cap, coolant reservoir and fuse holders (behind tool box).

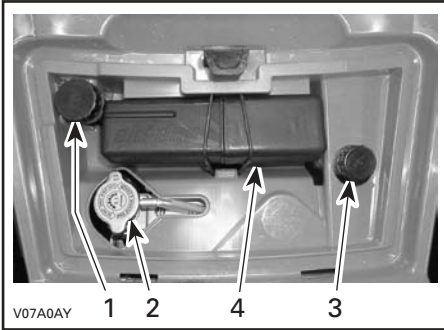

1. Rear brake fluid reservoir
2. Radiator cap
3. Coolant reservoir
4. Tool box

### 15) Rear Storage Compartment

Located in rear of vehicle. Convenient location to carry personal articles such as a spare spark plugs, first aid kit, etc. Unlatch cover, gently lift then remove cover.

The compartment is equipped with a drain plug. Remove plug to allow draining when necessary. Reinstall plug when finished.

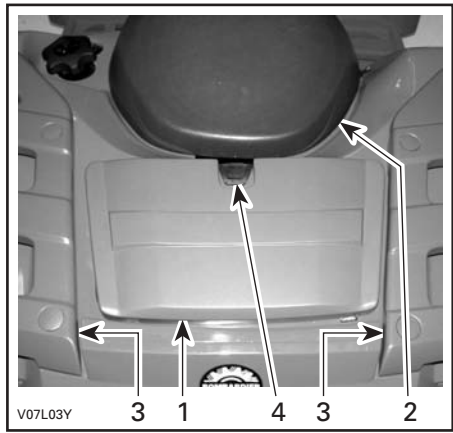

1. Rear storage compartment cover
2. Seat
3. Rear racks
4. Latch

### WARNING

When engine is running, always engage the PARK position on the transmission lever before opening cover. Never leave any heavy or loose breakable objects in the storage basket. Always latch cover before riding. If storage cover is removed to provide greater carrying area, ensure that cargo is secured and will not "fly out" when riding at speed on rough terrain. Slow down.



## 16) Seat Latch

Located underneath the rear end of seat. It allows the removal of seat to give access to engine compartment.



1. Seat latch

## Seat Removal

Push latch forward while gently lifting rear of seat. Pull seat rearward. Continue lifting movement until you can release the front retaining device then completely remove seat.

## Seat Installation

Insert front tabs of seat into frame hook. When seat rests in its position, firmly push seat down to latch.

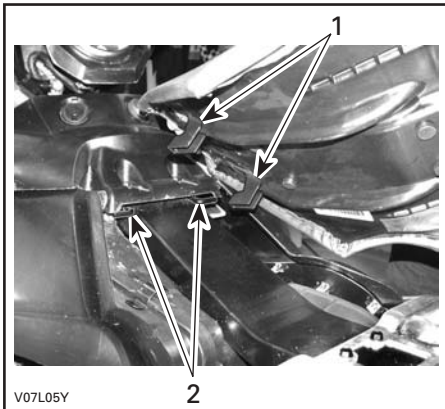

1. Insert these tabs in hooks
2. Hooks

## WARNING

Periodically verify the seat lock pin and tighten if needed. Make sure seat is securely latched before riding.

## 17) Front/Rear Cargo Rack

Located on top of chassis at front and rear. Convenient rack to carry gear.

## WARNING

Ensure to properly secure material to rack. Do not overload. Ensure load does not interfere with visibility and/or steering. Do not carry passenger(s).

Refer to SPECIFICATIONS for carrying loads and cargo weight distribution recommendations.

## 18) Trailer Hitch

Located near rear axle. Convenient hitch to install a ball to tow a trailer or other equipment. Install the proper ball size as per trailer manufacturer recommendations. Refer to SPECIFICATIONS for carrying loads and towing recommendations.

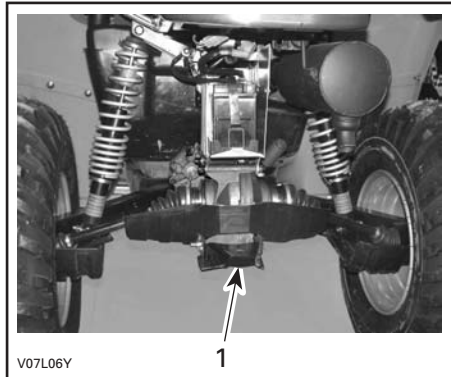

1. Trailer hitch

## **WARNING**

Ensure to install the proper ball size that matches the equipment you will tow.

**NOTE:** Follow manufacturer instructions for proper attachment.

### **19) Radiator Cap**

Located in service compartment, under access panel.

## **WARNING**

To prevent burning yourself do not remove the radiator cap if the engine is hot.

To remove the radiator cap, press and turn it counterclockwise. Reverse the removal procedure to install.

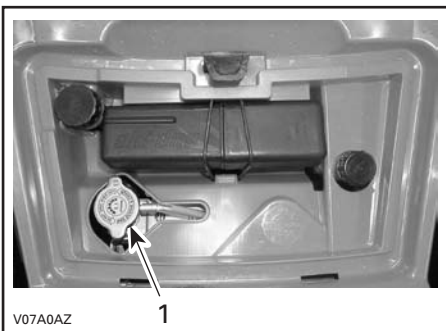

1. Radiator cap

### **20) 12-Volt Power Outlet**

It is located on the console. Convenient for handheld spotlight or other portable equipment.

Remove protective cap to use. Always reinstall protective cap after use to protect against weather.

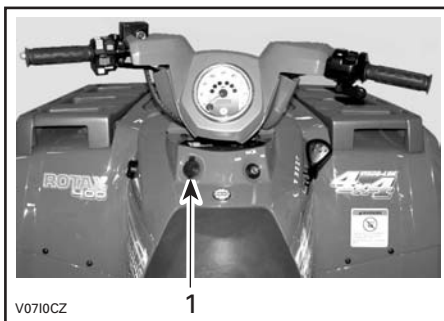

1. Power outlet

Do not exceed the rating capacity. See SPECIFICATIONS.

An auxiliary supply is available to connect additional accessories. Two wires are hidden in the wiring harness at the rear of vehicle. See an authorized Bombardier ATV dealer for more details.

### **21) Fuses**

The electrical system is protected with fuses. Refer to MAINTENANCE for details.

The fuse holders are located in the service compartment (behind tool box).

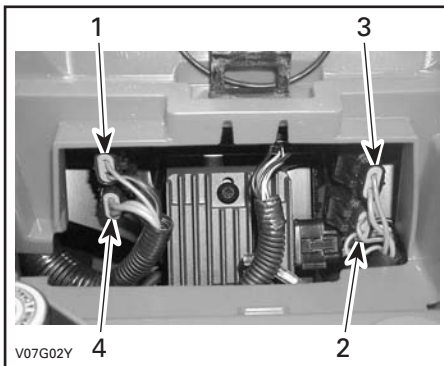

#### **FUSES LOCATION**

1. Accessories
2. Fan
3. Main
4. Charging system

## 22) Tool Box

The tool box is located in the service compartment. It contains tools for basic maintenance, the *Operator's Guide* and the *Safety Handbook*.

The tools included in the tool box are:

- pliers (1)
- screwdriver (1)
- open wrench 10/13 mm (1)
- open wrench 15/17 mm (1)
- socket wrench 10/13 mm (1)
- socket wrench 16/18 mm (1)
- tire pressure gauge (1)
- Allen key 3 mm (1)
- shock absorber key (1)
- fuse 30 A (1)
- fuse 20 A (1)
- fuse 15 A (1).

## 23) Rewind Starter Handle

The rewind starter handle is provided as an emergency starting device.

Follow the usual starting procedure; but use the rewind starter instead of the electric starter.

Located on right side of vehicle. Auto-rewind type. To engage mechanism, pull handle slowly until a resistance is felt then continue to slowly pull the handle until the compression stroke **peak** (strong rotating resistance) is overpassed then, pull vigorously. Slowly release handle.

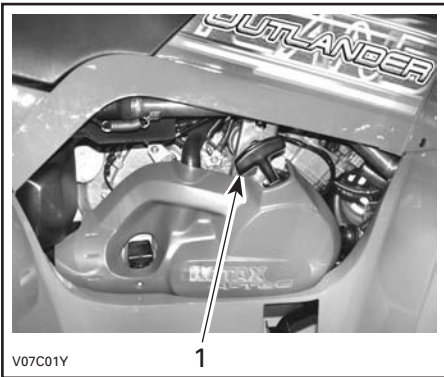

1. Rewind starter handle

## 24) Dipstick

Located on the right side of engine. Allow to check the oil level in the engine.



1. Dipstick

---

# LIQUIDS

While reading this *Operator's Guide*, remember that:

## WARNING

Indicates a potential hazard that, if not avoided, could result in serious injury or death.

This section specifies the recommended liquids and procedures to check their levels. Refer to MAINTENANCE for procedures to replace the liquids.

## Fuel

### Recommended Fuel

Use regular unleaded gasoline or gasohol containing less than 10% of ethanol or methanol, available from most service stations. The gasoline used must have an octane number of 87 ((R + M)/2) or higher.

**NOTE:** In most service station, pump octane number corresponds to (R + M)/2 octane number. Usually a sticker can be found on the pump.

**CAUTION:** Never experiment with other fuels. The use of unrecommended fuel can result in vehicle performance deterioration and damage to critical parts in the fuel system and engine components.

**CAUTION:** Never mix oil with fuel. This ATV has a 4-stroke engine. Oil must be added to engine base only.

## Fuel Level

### WARNING

Always stop engine before refueling. Open cap slowly. If a differential pressure condition is noticed (whistling sound heard when loosening fuel tank cap) have vehicle inspected and/or repaired before further operation. Fuel is flammable and explosive under certain conditions. Never use an open flame to check fuel level. Never smoke or allow flame or spark in vicinity. Always work in a well-ventilated area. Never top up the fuel tank before placing the vehicle in a warm area. As temperature increases, fuel expands and may overflow. Always wipe off any fuel or oil spillage from the vehicle.

## Engine/Transmission Oil

### Recommended Oil

Use 4-stroke engine oil that meets or exceeds the requirements for API service classification SG, SH or SJ. Always check the API service label on the oil container to be sure it includes the letters SG, SH or SJ. Only use high-quality high-detergent oil.

**NOTE:** The same oil lubricates both engine and transmission. For improved overall performance and wear protection use Bombardier synthetic oil 5W40 (P/N 293 600 039).

# Oil Viscosity

SAE 5W30 is recommended for all seasons.

However, during the hottest days of the summer and bitter cold days of the winter, refer to the following chart to select the proper viscosity.

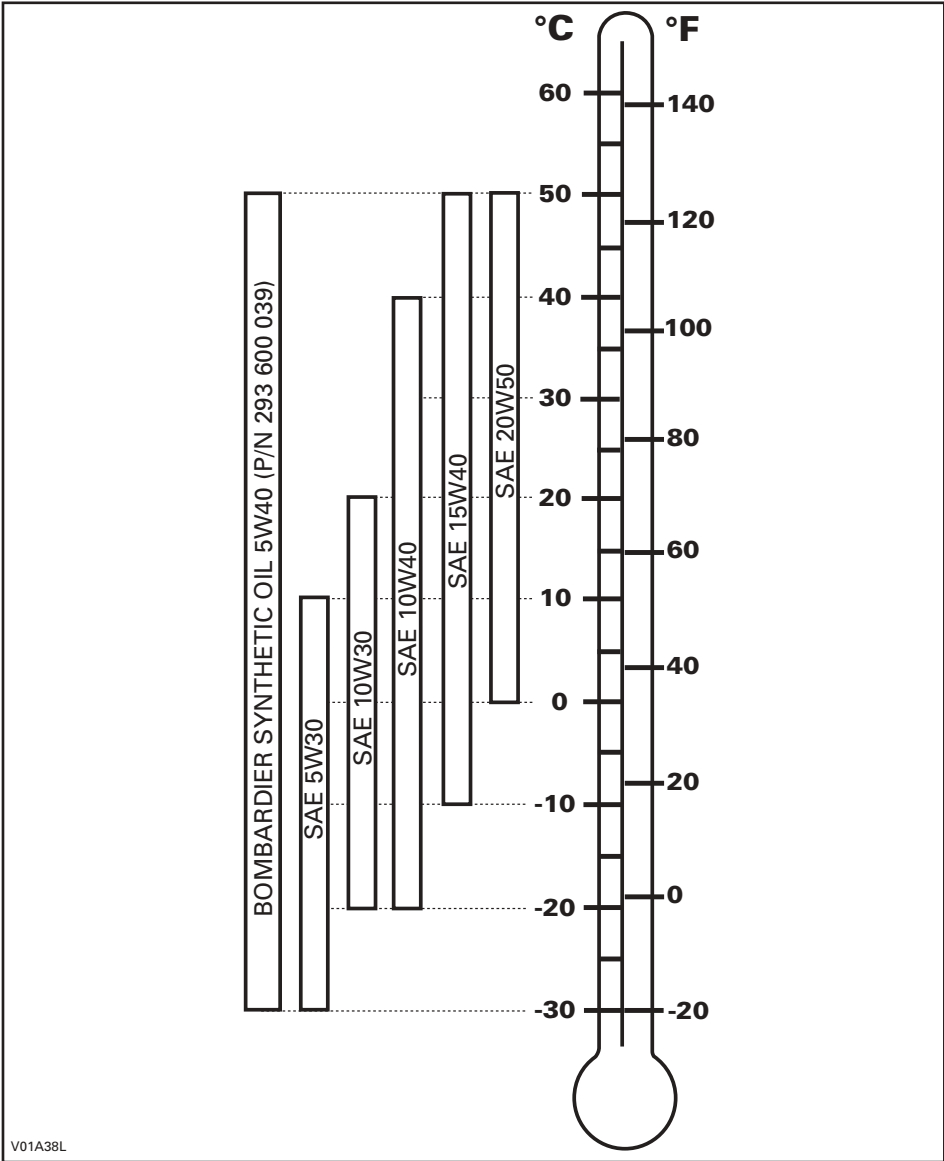

V01A38L

## Oil Level

**CAUTION:** Check level frequently and refill if necessary. Do not overfill. Operating the engine/transmission with an improper level may severely damage engine/transmission. Wipe off any spillage.



### RH SIDE OF ENGINE

#### 1. Dipstick

With vehicle on a level surface and engine cold, not running, check the oil level as follows:

1. Unscrew dipstick then remove it and wipe clean.
2. Reinstall dipstick, screw in it completely.
3. Remove and check oil level. It should be near or equal to the upper mark.

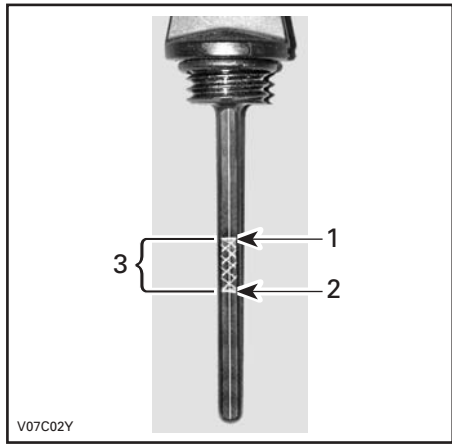

1. Full
2. Add
3. Operating range

4. Add oil up to upper mark if required.
5. To add oil, remove dipstick. Place a funnel into the dipstick tube and fill with the recommended oil. **Do not overfill.**
6. Properly tighten dipstick.

## Engine Coolant

### Recommended Coolant

Always use ethylene-glycol antifreeze containing corrosion inhibitors specifically for internal combustion aluminum engines.

Cooling system must be filled with water and antifreeze solution (50% water, 50% antifreeze) or with Bombardier premixed coolant (P/N 293 600 038).

### Coolant Level

#### **WARNING**

Check coolant level with engine cold. Never add coolant in cooling system when engine is hot.

Remove access panel.

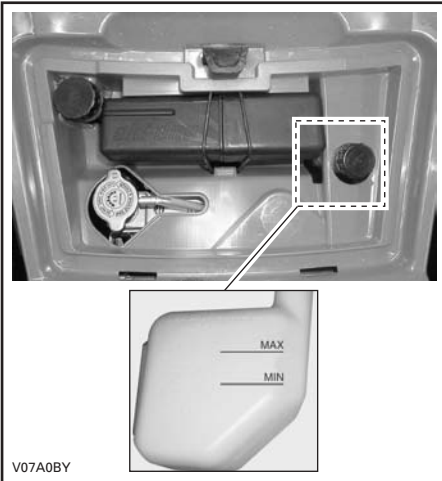

With vehicle on a level surface, liquid should be between MIN. and MAX. level marks of coolant reservoir.

**NOTE:** When checking level at temperature lower than 20°C (69°F), it may be slightly lower than MIN. mark.

Add coolant up to MAX. mark if required. Use a funnel to avoid spillage. **Do not overfill.** Properly reinstall and tighten filler cap and re-install access panel.

If the coolant is added in the coolant reservoir, check the level in the radiator too. Add coolant if necessary.

## **⚠ WARNING**

To prevent burning yourself do not remove the radiator cap if the engine is hot.

**NOTE:** A cooling system that frequently requires coolant is the indication of leaks or engine problems. See an authorized Bombardier ATV dealer.

## **Coolant Replacement**

Refer to MAINTENANCE section.

## **Brake Fluid**

### **Recommended Fluid**

Always use brake fluid meeting the specification DOT 4 only.

**CAUTION:** To avoid serious damage to the braking system, do not use fluids other than the recommended one, nor mix different fluids for topping up.

### **Fluid Level**

With vehicle on a level surface, check brake fluid in reservoirs for proper level. They should be above MIN. mark.

Add fluid as required. **Do not overfill.**

Clean filler cap before removing.

**CAUTION:** Use only DOT 4 brake fluid from a sealed container. Do not use brake fluid taken from old or already opened containers.

**NOTE:** A low level may indicate leaks or worn brake pads. See an authorized Bombardier ATV dealer.

### **Brake Lever Fluid Reservoir**

Turn steering in the straight-ahead position to ensure reservoir is level. Check the brake fluid level, the reservoir is full when the fluid reaches of the top of window.

Visually inspect lever boot condition. Check for cracks, tears, etc. Replace if damaged.



## Brake Pedal Fluid Reservoir

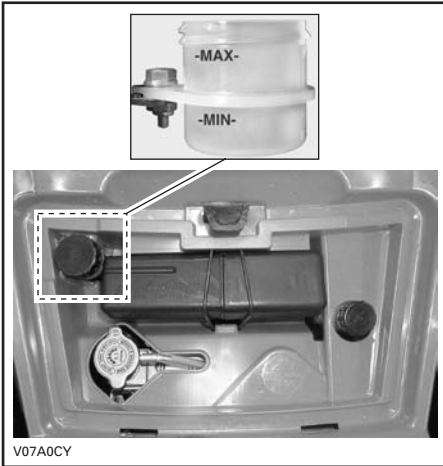

## Battery

This vehicle is equipped with a dry type battery that requires no maintenance.

### Cleaning

Clean battery post with a wire brush. Apply dielectric grease on post to protect against oxidation.

### Removal

Disconnect BLACK (-) cable first then RED (+) cable.

## WARNING

Always respect this order for disassembly; disconnect BLACK (-) cable first.

Remove the holding strap then pull the battery out of frame.

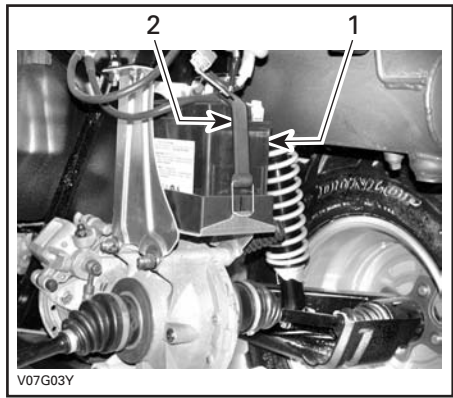

1. Battery
2. Holding strap

### Installation

Reinstall battery in vehicle.

## WARNING

Connect RED (+) cable first then BLACK (-) cable. Always connect RED (+) cable first.

**NOTE:** Place the BLACK (-) cable between holding strap and battery.



---

# BREAK-IN PERIOD

## Engine

A break-in period of 10 operating hours is required before running the vehicle at sustained full throttle.

**CAUTION:** Never mix oil with fuel. This vehicle has a 4-stroke engine. Oil must be added to engine base only.

During this period, maximum throttle should not exceed 3/4. **However, brief full acceleration and speed variations contribute to a good break-in.** Continued wide open throttle accelerations, prolonged cruising speeds and engine overheating are detrimental during the break-in period.

## Belt

A new belt requires a break-in period of 50 km (30 miles). Avoid strong acceleration/deceleration, pulling a load or high speed cruising.

## 10-Hour Inspection

As with any precision piece of mechanical equipment, we suggest that after the first 10 hours or 30 days after the purchase, whichever comes first, your vehicle be inspected by an authorized Bombardier ATV dealer. This inspection will give you the opportunity to discuss the unanswered questions you may have encountered during the first hours of operation.

---

The 10-hour inspection is at the expense of the vehicle owner.

---

While reading this *Operator's Guide*, remember that:

### **WARNING**

Indicates a potential hazard that, if not avoided, could result in serious injury or death.

---

# PRE-OPERATION CHECK

## **WARNING**

The pre-operation check is very important prior to operating the vehicle. Always check the proper operation of critical controls, safety features and mechanical components before starting. If not done as specified here, severe injury or death might occur.

- Apply parking brake and check if it operates properly.
- Check tire pressure and condition.
- Check wheels and bearings for wear and damage.
- Check location of controls and ensure they work properly.
- Verify steering operates freely.
- Activate throttle control lever several times to ensure it operates freely. It must return to idle position when released.
- Activate the brake lever and brake pedal to make sure the brakes fully apply. Lever and pedal must fully return when released.
- Ensure transmission lever is working then reset in PARK position.
- Check fuel, oil and coolant levels.
- Check for oil leaks on the engine/ transmission and drive train components.
- Ensure fuel valve is in fully open position (ON).
- Clean headlights and taillight.
- Ensure front storage cover compartment is properly latched.
- Ensure seat is properly latched.
- If you transport cargo, respect load capacity. Ensure cargo is properly secured to the racks.
- If you are pulling a trailer or other equipment, ensure it respects the tongue capacity and towing capacity. Ensure trailer is properly secured to hitch.
- Look and feel for loose parts while engine is off. Check fasteners.
- Ensure the path of travel is free of persons and obstacles.
- Check operation of ignition switch, start button, engine stop switch, headlights, dimmer switch, taillight and indicator lights.
- Start engine and drive forward slowly a few feet and apply all brakes individually to test them.
- Check operation of 2WD/4WD selector.

**Correct any problem you may have found. See an authorized Bombardier ATV dealer as necessary.**

# OPERATING INSTRUCTIONS

## General

Transmission lever must be on PARK or NEUTRAL to allow engine starting.

**NOTE:** For your convenience, an override mode allows the engine to be started with the transmission lever in any position. Press and hold the brake lever or the brake pedal while pressing the start button.

To start engine, place the engine stop switch to RUN position, insert key in ignition switch and turn to ON then press start button.

## Initial Cold Starting

Insert key in ignition switch and turn to ON.

**NOTE:** Do not forget, place the engine stop switch to RUN position.

In cold weather, colder than 0°C (32°F), place the choke lever in full position.



1. Full choke position

Press start button and hold until engine starts.

**CAUTION:** Do not hold start button more than 30 seconds. A rest period should be observed between the cranking cycles to let starter cool down. Pay attention not to discharge battery.

**NOTE:** Throttle assist may be used to help engine starting faster. Press the throttle lever slightly. If too much throttle is used the choke system will not be activated.

Release start button immediately when engine has started.

After a few seconds, move the choke lever from full choke position to an intermediate position until the best engine RPM is achieved.

**NOTE:** Over using choke may flood engine and make it hard to start. Refer to SPECIAL PROCEDURES if it occurs.

When the engine is warm, push the choke lever to OFF and release brakes.

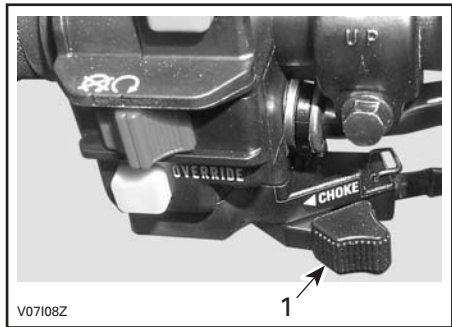

1. OFF position

## Warm Engine Starting

Start the engine as explained above but without any choke. If the engine will not start after two 5-second attempts with the electric starter, pull the choke lever and place it half way position. Start the engine without activating the throttle lever. After few seconds, push the choke lever to OFF.

## Emergency Manual Starting

### **WARNING**

Always place transmission lever on **PARK** or **NEUTRAL** before starting engine manually.

Manual start is provided in the event electric start does not work.

If the engine indicator light is turned off, it indicates the electrical system is in the auto shut-down mode. Turn the ignition key OFF then ON to reactivate it.

Follow the same procedure as starting procedures above except use the rewind starter to start instead.

Grasp manual starter handle firmly and, slowly, crank engine until a resistance appears.

Pass this resistance and release the handle.

Take again the handle firmly and crank engine.

Repeat this procedure completely if necessary.

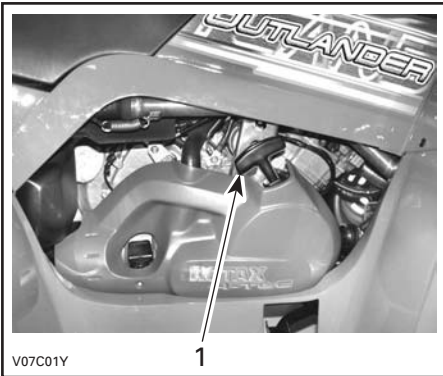

1. Grasp manual starter handle firmly and crank engine

## Stopping the Engine

### **WARNING**

Avoid parking on an incline surface.

Release throttle and completely stop the vehicle.

Apply the parking brake by using brake lever lock on brake lever.

Set transmission lever in **PARK** position.

Push the engine stop switch in **OFF** position.

Turn key in ignition switch to **OFF**.

Remove key from ignition switch.

## Shifting the Transmission

Let engine idle to warm up.

Apply brakes and select the desired gear range H/L.

**NOTE:** The brake must be applied when the transmission lever is engaged in the park position.

Release brakes.

**CAUTION:** Make sure parking brake is fully disengaged before operating the ATV.

Gradually press the throttle lever to increase engine speed and thus engaging the continuously variable transmission (CVT).

At the opposite, when the throttle lever is released, the engine speed decreases.

## Using the Reverse

**CAUTION:** When changing from forward to reverse, or vice-versa, always completely stop the vehicle and apply the brake prior to moving the transmission lever.

The same procedures as SHIFTING THE TRANSMISSION above apply except for the following.

Set the transmission lever in REVERSE position.

## 2WD/4WD Selector

The 4WD mode may be selected or deselected when the vehicle is stopped.

**CAUTION:** The vehicle must be stopped to engage or disengage 2WD/4WD selector. Mechanical damage may occur if selector is engaged or disengaged while driving.

**CAUTION:** If the rear wheels are spinning, release the throttle and wait engine return to the idle before selecting the 4WD mode. The 4WD mode is engaged when the selector is pushed downwards.

To deselect the 4WD mode, press the selector on 2WD.



### 2WD MODE

When the selector is located on the 2WD, the vehicle is in 2 wheel drive at all time.



### 4WD MODE

---

# SPECIAL PROCEDURES

## Flooded Engine

When the engine does not start after several attempts, the engine may be fuel flooded. Proceed as follows.

Turn ignition switch to ON and ensure choke is not applied.

Ensure the transmission lever is on PARK.

Fully press throttle lever and hold while starting the engine.

As soon as the engine starts, release throttle lever. Do not race engine.

### If it does not work:

Clean the spark plug cable area then remove it. Remove the spark plug (tools are supplied in tool box).

### WARNING

Always wear eye protector and gloves when the spark plug hole is cleaned.

Crank engine several times. Add a small quantity of engine oil in cylinder (equivalent to a cap of oil quart). Install new spark plug if possible or clean and dry spark plug.

Start engine as explained above. If engine continues to flood, see an authorized Bombardier ATV dealer.

## Engine Overheat

If engine overheats and indicator light turns on, try the following:

Check and clean radiator fins. See MAINTENANCE section.

### WARNING

The radiator can be very hot, wear gloves before touching radiator.

Reduce vehicle speed but try to keep vehicle moving to supply air to radiator. If engine is still overheating after approximately one minute, stop vehicle and set transmission to PARK. Stop engine.

Place the ignition switch to ON position (**DO NOT RESTART ENGINE YET**). The radiator fan will cool the radiator.

Let engine cool down. Check coolant level and refill if possible.

### WARNING

Never refill cooling system when engine is hot.

See an authorized Bombardier ATV dealer as soon as possible.

## Post-Operation Care

When vehicle is used in salt-water environment (beach area, launching/loading boats etc.), rinsing the vehicle with fresh water is necessary to preserve vehicle and its components. Metallic parts lubrication is highly recommended. Use BOMBARDIER LUBE (P/N 293 600 016). This must be performed at the end of each operating day.

When vehicle is operated in muddy conditions, rinsing the vehicle is recommended to preserve vehicle and its components and to keep lights clean.

**NOTE:** Never use the high pressure washer to clean the vehicle **USE LOW PRESSURE ONLY (like a garden hose)**. The high pressure can cause electrical or mechanical damages.

## Turn Over

When vehicle is turned over or stays tilted on the side, replace the vehicle in its normal operating position (on all four wheels) and wait 3 to 5 minutes before starting engine. Before starting engine, check engine oil level and re-fill if necessary. If the oil pressure light stays ON after starting engine, stop engine and see an authorized Bombardier ATV dealer as soon as possible.

## ATV Immersion

Should the ATV become immersed, it will be necessary to take it to an authorized Bombardier ATV dealer as soon as possible. **DO NOT START THE ENGINE!** Immersion of the ATV can cause serious damage if the correct re-start procedure is not followed.

## Storage and Preseason Preparation

### **WARNING**

Have an authorized Bombardier ATV dealer inspect fuel system integrity as specified in LUBRICATION AND MAINTENANCE CHART.

When a vehicle is not in use for more than one month, proper storage is a necessity. See an authorized Bombardier ATV dealer for proper procedures.

When using your ATV after storage, a preparation is required. See an authorized Bombardier ATV dealer for proper procedures.

# MAINTENANCE CHART

The maintenance is very important, if you are not familiar with safe service practices and adjustment procedures, see your authorized Bombardier ATV dealer.

LUBRICATION AND MAINTENANCE CHART  I: Inspect, verify, clean, adjust, lubricate, replace if necessary C: Clean L: Lubricate R: Replace	INITIAL INSPECTION 10 h or 30 days OR 300 km (185 m.) ①	EVERY				TO BE PERFORMED BY
		25 h OR 750 km (470 m.)	50 h OR 1500 km (930 m.)	100 h OR 1 YEAR OR 3000 km (1865 m.)	200 h OR 2 YEARS OR 6000 km (3730 m.)	
<b>ENGINE/TRANSMISSION</b>						
Engine/transmission oil and filter ④	R		R			CUSTOMER
Engine/transmission oil strainer cleaning					C	DEALER
Valve adjustment	I			I		DEALER
Engine mount fasteners	I			I		DEALER
Exhaust system	I			I		DEALER
Spark arrester				C		CUSTOMER
Condition of seals	I			I		DEALER
Coolant ④	I			②	R	CUSTOMER
Radiator cap/cooling system pressure test	I				I	DEALER
Radiator condition/cleanliness (radiator fins) ③	I		I			CUSTOMER
Drive belt				I		CUSTOMER
Cleaning/condition of drive and driven pulleys				C		DEALER
CVT air inlet/outlet duct condition/cleanliness and sealing	I		I			DEALER
Rewind starter rope condition				I		DEALER
<b>FUEL SYSTEM</b>						
Air filter ④		C ③		R ③		CUSTOMER
Fuel lines and connections	I			I		DEALER
Fuel tank strainer					R	DEALER
Carburetor	I			I		DEALER
<b>ELECTRICAL SYSTEM</b>						
Spark plug	I			R		DEALER
Battery connections	I		I			CUSTOMER
Wiring harnesses, cables and lines	I			I		DEALER
Condition of ignition switch, start button and engine stop switch ④	I			I		CUSTOMER
Condition of lighting system (HI/LO intensity, brake light, headlight aiming, etc.) ④	I			I		CUSTOMER



LUBRICATION AND MAINTENANCE CHART  I: Inspect, verify, clean, adjust, lubricate, replace if necessary C: Clean L: Lubricate R: Replace	INITIAL INSPECTION 10 h or 30 days OR 300 km (185 m.) ①	EVERY				TO BE PERFORMED BY
		25 h OR 750 km (470 m.)	30 h OR 1500 km (930 m.)	100 h OR 1 YEAR OR 3000 km (1865 m.)	200 h OR 2 YEARS OR 6000 km (3730 m.)	
<b>DRIVE TRAIN</b>						
Front/rear drive shaft boots and protectors ④	I	I				CUSTOMER
Rear drive shaft joints			I			DEALER
Rear propeller shaft joints (grease fittings)	I		L			DEALER
Wheel bearings condition				I		CUSTOMER
Front/rear differential oil level, seals and vents	I		I		R	DEALER
<b>STEERING/CONTROL SYSTEMS</b>						
Handlebar fasteners				I		DEALER
Throttle/housing/cable ④	I		I			CUSTOMER
Choke condition ④	I		I			CUSTOMER
Steering system ③	I			I		DEALER
Tie rod ends			I			DEALER
Wheel nuts/studs	I		I			CUSTOMER
Wear/pressure of tires ④	EVERY RIDE					CUSTOMER
Front wheels alignment	I			I		DEALER
<b>SUSPENSION</b>						
Trailing arms ④				I		DEALER
Shock absorbers ④			I			DEALER
A-arms			I			CUSTOMER
<b>BRAKE</b>						
Brake fluid front/rear ④	I	I			R ⑤	CUSTOMER
Brake pads		I				CUSTOMER
Brake system (discs, hoses etc.)				I		CUSTOMER

<b>LUBRICATION AND MAINTENANCE CHART</b> <b>I:</b> Inspect, verify, clean, adjust, lubricate, replace if necessary <b>C:</b> Clean <b>L:</b> Lubricate <b>R:</b> Replace	<b>INITIAL INSPECTION</b> <b>10 h or 30 days</b> <b>OR 300 km (185 m.)</b> ①	<b>EVERY</b>				<b>TO BE PERFORMED BY</b>
		<b>25 h</b> <b>OR 750 km (470 m.)</b>	<b>50 h</b> <b>OR 1500 km (930 m.)</b>	<b>100 h OR 1 YEAR</b> <b>OR 3000 km (1865 m.)</b>	<b>200 h OR 2 YEARS</b> <b>OR 6000 km (3730 m.)</b>	
<b>BODY/FRAME</b>						
Engine compartment	<b>C</b>		<b>C</b>			CUSTOMER
Frame				<b>I</b>		DEALER
Hitch/trailer ball condition (if installed)	<b>I</b>		<b>I</b>			CUSTOMER
Chassis fasteners			<b>I</b>			CUSTOMER
Seat fasteners	<b>EVERY RIDE</b>					CUSTOMER
Vehicle cleaning and protection			<b>C</b>			CUSTOMER

- ① To be performed by an authorized Bombardier ATV dealer. The initial maintenance is very important and must not be neglected.
- ② Every 100 hours, check coolant strength.
- ③ More often under severe use such dusty area, sand, snow, wet or muddy conditions.
- ④ Pre-ride inspection item.
- ⑤ To be performed by an authorized Bombardier ATV dealer.

# MAINTENANCE

While reading this *Operator's Guide*, remember that:

## WARNING

Indicates a potential hazard that, if not avoided, could result in serious injury or death.

## WARNING

Unless otherwise specified, engine should not be running for all maintenance procedures.

## WARNING

Should removal of a locking device (e.g. lock tabs, self-locking fasteners, etc.) be required when undergoing disassembly/assembly, always replace with a new one.

The following covers the maintenance items that can be performed by the customer if desired. Other items found in maintenance chart must be performed by an authorized Bombardier ATV dealer.

**NOTE:** Among other things, this section gives the procedures to replace the liquids. Refer to LIQUIDS for procedures to check levels and refill.

## Engine/Transmission

### Oil Change and Oil Filter Replacement

Oil and filter are to be replaced at the same time. Oil change should be done with a warm engine.

## WARNING

The engine oil can be very hot. To prevent burning yourself, do not remove the engine drain plug or the filter cover if the engine is hot. Wait until engine oil is warm.

Ensure vehicle is on a level surface.  
Remove dipstick.  
Clean the oil drain plug area.  
Place a drain pan under the oil drain plug area.  
Unscrew oil drain plug.

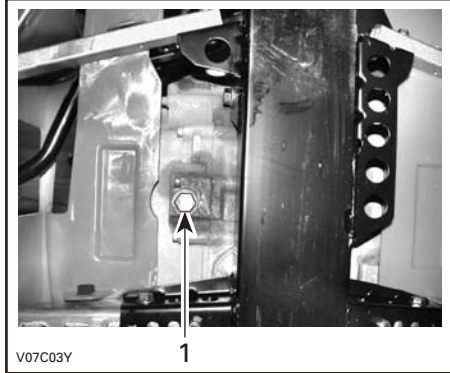

#### 1. Oil drain plug

Allow enough time for oil to flow out of oil filter.

Remove the right engine cover.  
Unscrew the oil filter cover.

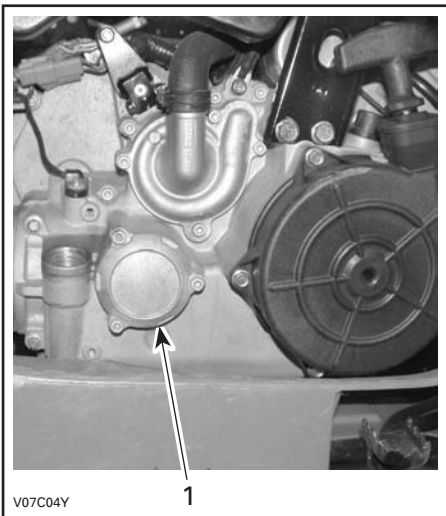

1. Oil filter cover

Remove the oil filter and replace with a new filter.

**NOTE:** Check the cover O-ring and change it if necessary.

Wipe out any oil spillage on engine.

Change gasket on oil drain plug. Clean gasket area on engine and oil drain plug then reinstall plug. Refill engine at the proper level with the recommended oil. Refer to SPECIFICATIONS for capacity.

Start engine and let idle for a few minutes. Ensure oil filter area and oil drain plug areas are not leaking.

Stop engine. Wait a while to allow oil to flow down to crankcase then check oil level. Refill as necessary.

Dispose of oil as per your local environmental regulations.

## Oil Strainer Cleaning

The oil strainer must be cleaned every 200 hours or every 2 years or every 6000 km (3730 m.).

Contact an authorized Bombardier ATV dealer.

## Coolant Replacement

### WARNING

To prevent burning yourself, do not remove the radiator cap or loosen the coolant drain plug if the engine is hot.

Open the access panel and remove the radiator cap.

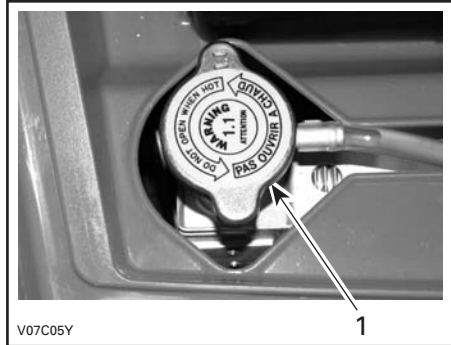

1. Radiator cap

On the right side of vehicle, remove the engine cover.

Unscrew the coolant drain plug and drain the coolant into a suitable container.

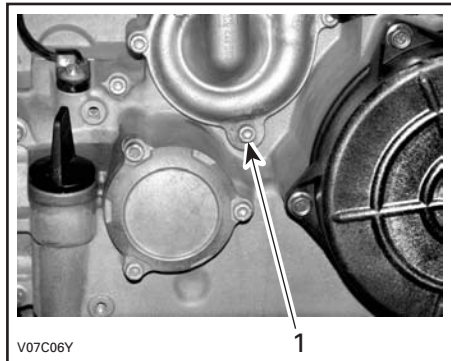

1. Coolant drain plug

**NOTE:** Do not unscrew the coolant drain plug completely.

Disconnect the engine temperature sensor connectors then unscrew the bleeding screw on the top of thermostat housing.

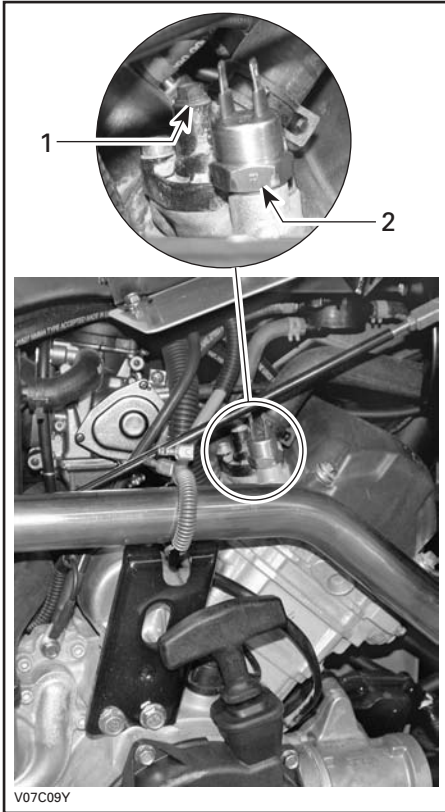

1. Bleeding screw
2. Engine temperature sensor

Drain the system completely and reinstall the coolant drain plug.  
Pinch hose between radiator and thermostat housing with a large hose pincher (P/N 529 032 500).

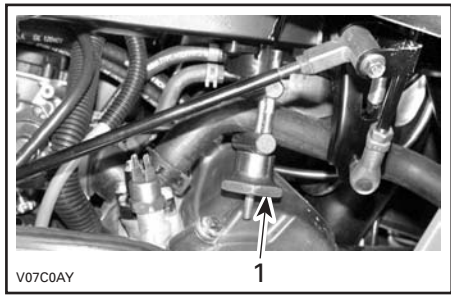

1. Hose pincher

Fill the radiator until the coolant comes out by the thermostat housing hole. Install the bleeding screw then remove the hose pincher.

Complete the radiator filling.

Check the level in the coolant reservoir and refill if necessary.

Run engine at idle with the radiator cap off. Slowly add additional coolant if necessary.

At this point, wait until engine reaches normal operating temperature. Depress the throttle lever two or three times; then add coolant if required.

Install radiator cap. Inspect all connections for leaks and check coolant level in the reservoir.

## Drive Belt

To check the drive belt, remove the CVT cover on the left side of vehicle.

Measure and verify the drive belt. If the drive belt width is equal or less than 30 mm (1-3/16 in) or if flat spots, cracks or other damages are visible, see an authorized Bombardier dealer to replace the drive belt.

## Valve Adjustment

See an authorized Bombardier ATV dealer for valves adjustment.

Insufficient clearance will cause loss of power and possibly damage the valves. Excessive clearance will cause noise.

## Spark Arrester

The muffler must be periodically purged of accumulated carbon.

### WARNING

Never run engine in an enclosed area. Never perform this operation immediately after the engine has been run because exhaust system is very hot. Make sure that there are no combustible materials in the area. Wear eye protection and gloves. Never stand behind the vehicle while purging exhaust system. Respect all applicable laws and regulations.

Select a well-ventilated area and make sure the muffler is cool.

Place transmission on PARK position.

Remove the clean-out plug from muffler.

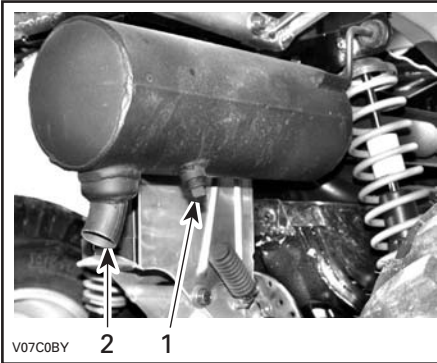

1. Clean-out plug
2. Muffler

Block the end of muffler with a shop rag and start engine.

Momentarily increase engine RPM several times to purge accumulated carbon out of the muffler.

Stop engine and allow muffler to cool.

Reinstall the clean-out plug.

## Radiator

Periodically check the radiator area for cleanliness.



1. Radiator

Inspect radiator fins. They must be clean, free of mud, dirt, leaves and any other deposit that would prevent the radiator to cool properly.

Remove the deposits as much as you can with your hands. If water is available in proximity, try rinsing the radiator fins.

If available, use a garden hose to rinse the radiator fins.

### WARNING

Never clean radiator with your hands when it is hot. Let the radiator cool down before cleaning.

**CAUTION:** Be careful not to damage the radiator fins when cleaning. Do not use any object/tool that could damage the fins. The fins are purposely thin parts to allow efficient cooling. **WHEN HOSING, USE LOW PRESSURE ONLY, NEVER USE A HIGH PRESSURE WASHER.**

See an authorized Bombardier dealer to check the performance of the cooling system.

# Air Intake System

## Air Filter Cleaning/Draining

Periodically inspect air filter box drain tube for water or deposits.

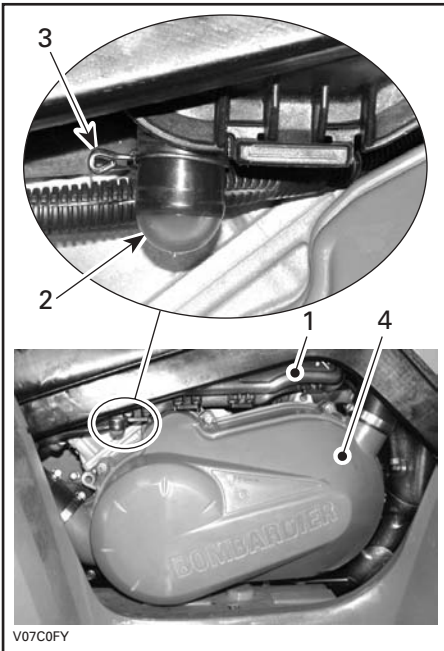

1. Air filter box
2. Drain tube
3. Clamp
4. CVT cover

**NOTE:** If vehicle is used in dusty area, inspect more frequently than specified in MAINTENANCE CHART.

If water/deposits are found, squeeze and remove the clamp. Pull drain tube out.

**CAUTION:** Do not start engine when water is found in the drain tube.

When water/deposits are found, the air filter must be inspected/dried/replaced depending on its condition.

Remove air filter as explained below.

## Air Filter Removal

**CAUTION:** Never remove or modify any component in the air box. The engine carburetion is calibrated to operate specifically with these components. Otherwise, engine performance degradation or damage can occur.

Remove seat.

Release clamps and remove air filter box cover.

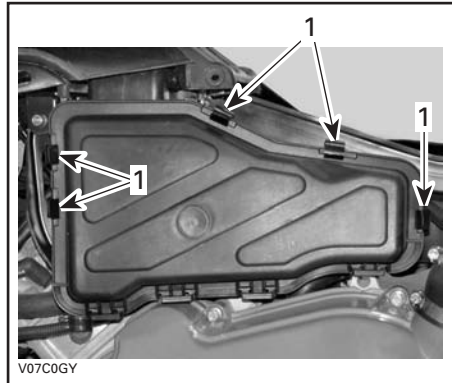

1. Release clamps

Loosen clamp and remove air filter.

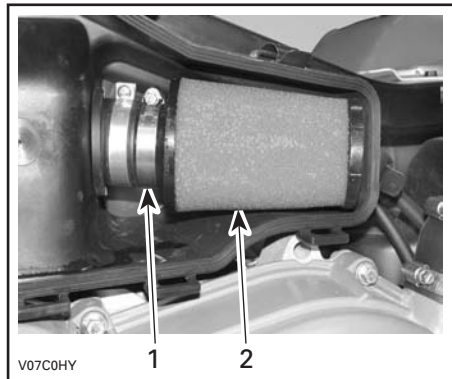

1. Clamp
2. Air filter

Pour cleaning solution (P/N 293 600 059 or an equivalent) into a bucket, dunk the filter multiple times until clean. Rinse with warm water.

While filter soaks, clean inside the air box. Then, let the filter dry completely. When the filter is dried, re-oil with air filter oil (P/N 293 600 058 or an equivalent).

### Air Filter Installation

Properly reinstall removed parts in the reverse order of their removal.

## Electrical

### Battery

#### **WARNING**

Never charge a battery while installed in vehicle.

Clean battery post with a wire brush. Apply dielectric grease on post to protect against oxidation.

### Fuses

If a fuse is damaged, replace it by one of the same rating.

**CAUTION:** Do not use a higher rated fuse as this can cause severe damage.

Fuses are located in the service compartment, behind tool box.

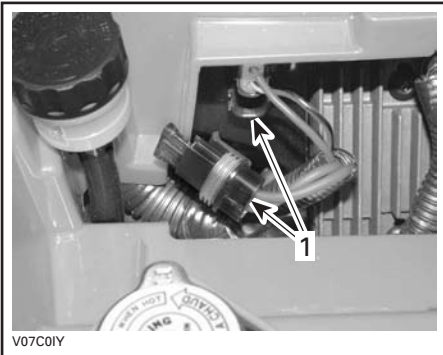

V07C01Y

1. Fuse holders

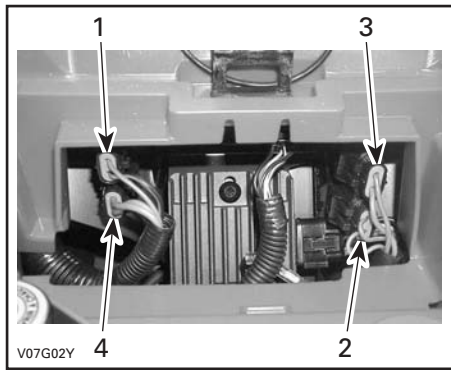

V07G02Y

1. Accessories (15 A)  
(power outlet and auxiliary supply)
2. Fan (20 A)
3. Main (20 A)
4. Charging system (30 A)

To remove fuse from holder, remove the fuse holder cover then pull fuse out. Check if filament is melted.

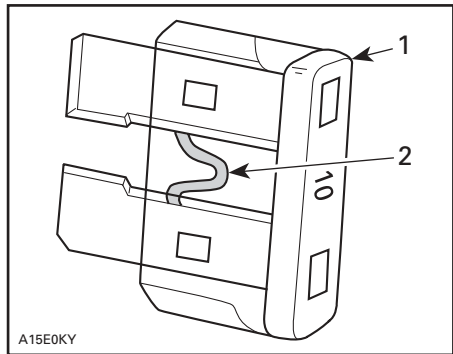

A15E0KY

#### TYPICAL

1. Fuse
2. Check if melted

## Bulb Replacement

Always check light operation after replacement.

### Headlights

**CAUTION:** Never touch glass portion of an halogen bulb with bare fingers, it shortens its operating life. If glass is touched, clean it with isopropyl alcohol which will not leave a film on the bulb.



Unplug connector from headlight.

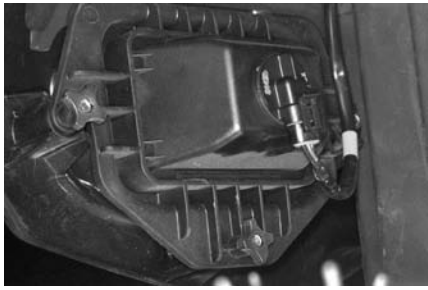

Rotate the bulb socket counterclockwise then remove headlight.

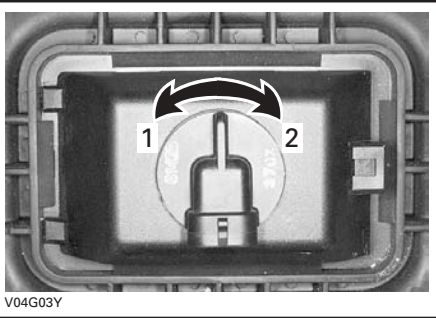

1. *Unlock*
2. *Lock*

Properly reinstall removed parts in the reverse order of their removal.

Adjust beam aiming as follows:

Turn knobs to adjust beam height and side orientation to your convenience. Adjust both headlights evenly.

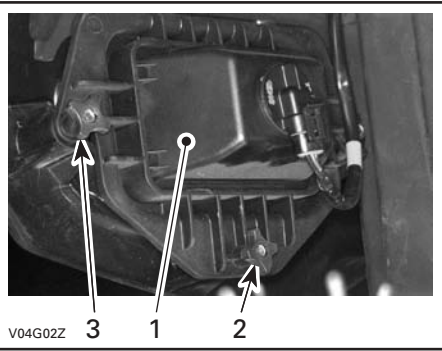

1. *Headlight cover*
2. *Beam height adjustment*
3. *Beam side adjustment*

## Taillight

Unscrew lens screws to expose bulb.

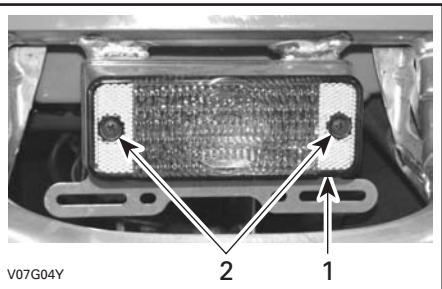

1. *Lens*
2. *Screws*

Push bulb in and hold while turning counterclockwise to release.

Install the new bulb by first pushing in while turning clockwise.

## Drive Train

### Drive Shaft Boot/Protector

#### Inspection

Visually inspect drive shaft protectors and boots conditions. Check protectors for damage or rubbing against shafts. Check boots for cracks, tears, leaking grease etc. Repair or replace damaged parts as necessary.

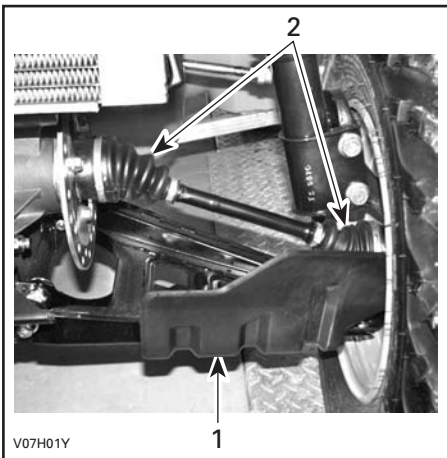

**FRONT OF VEHICLE**

1. Drive shaft protector
2. Drive shaft boots

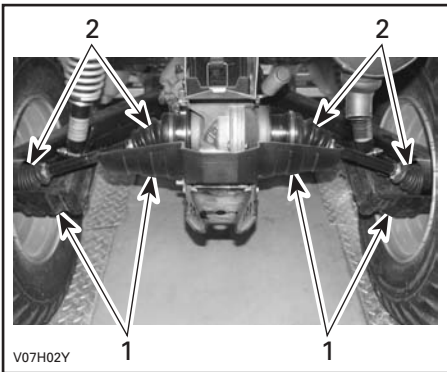

**REAR OF VEHICLE**

1. Drive shaft protector
2. Drive shaft boots

**Wheel**

Occasionally, wheel nuts should be removed to apply anti-seize lubricant on studs to ease future removal. This is particularly important when vehicle is used in salt-water environment or in mud. Remove one nut at a time, lubricate then retorque.

**Wheel Bearing Condition**

Push and pull the wheels from the upper edge to feel the play. See an authorized Bombardier ATV dealer if there is any play.

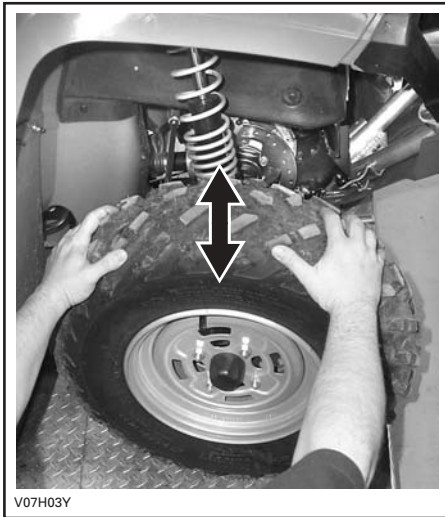

**Tires/Wheels**

**Tire Pressure**

**⚠ WARNING**

Tire pressure greatly affects vehicle handling and stability. Underpressure may cause tire to deflate and rotate on wheel. Overpressure may burst the tire. Always follow recommended pressure. Since tires are low-pressure types, a manual pump should be used.

Check pressure when tires are "cold" before using the vehicle. Tire pressure changes with temperature and altitude. Recheck pressure if one of these conditions has changed.

For your convenience, a pressure gauge is supplied in tool box.

TIRE PRESSURE		
	FRONT	REAR
RECOMMENDED	28 kPa (4 PSI)	31 kPa (4.5 PSI)
MINIMUM	24 kPa (3.5 PSI)	28 kPa (4 PSI)

Although the tires are specifically designed for off-road use, a flat may still occur. Therefore, it is recommended to carry a tire pump and a repair kit.

### Tire/Wheel Condition

Check tire for damage and wear. Replace if necessary.

Do not rotate tires. The front and rear tires have a different size. The tires are directional and their rotation must be kept in a specific direction for proper operation.

### Wheel Removal

Loosen nuts then lift vehicle. Place a support under vehicle. Remove nuts then remove wheel.

At installation, it is recommended to apply anti-seize lubricant on threads. Gently tighten nuts in a criss-cross sequence then apply a final torque of 70 N•m (52 lbf•ft).

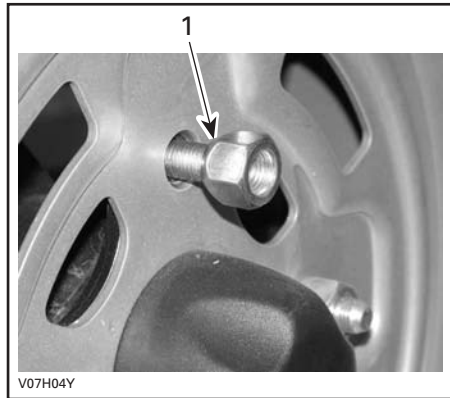

1. Taper side of nut

**CAUTION:** Always use the recommended wheel nuts (P/N 250 100 039). Using a different nut could cause damages to the rim.

## Steering/Control Systems

### Throttle Cable Lubrication

The throttle cable must be lubricated with cable lubricant (P/N 293 600 041) or an equivalent.

### WARNING

Using another lubricant could cause bad working of throttle lever/ cable.

Open the throttle lever housing.

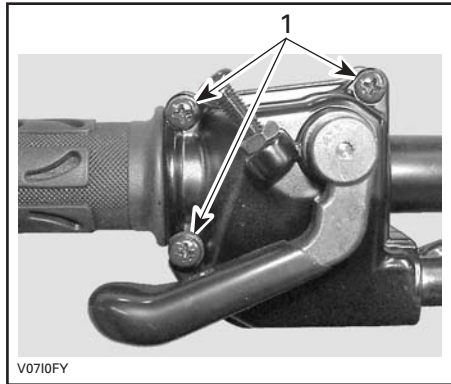

1. Remove these screws

Separate the housing. Slide rubber protector back to expose throttle cable adjuster.

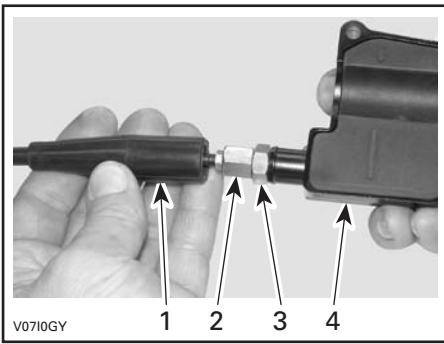

1. Cable protector
2. Throttle cable adjuster
3. Lock nut
4. Throttle lever housing

Screw in the throttle cable adjuster.

Remove:

- inner housing protector

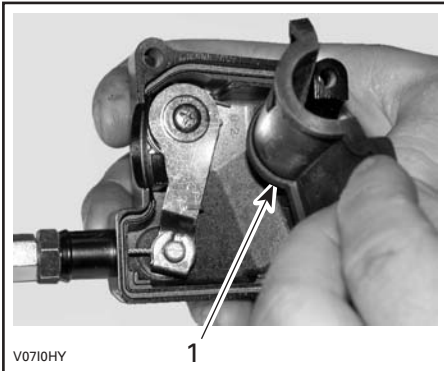

1. Inner housing protector

- the cable from the throttle lever housing.

**NOTE:** Slide cable in clip slot and remove the end of cable from clip.

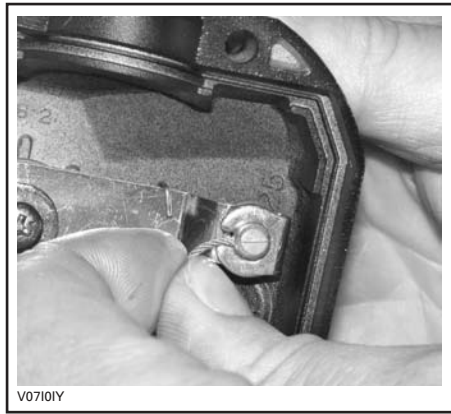

Remove the carburetor side cover.

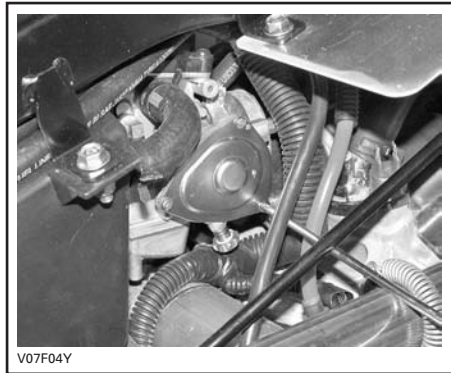

Insert the needle of lubricant can in the end of throttle cable adjuster.



## **WARNING**

Always wear eye protection and gloves when you lubricate a cable.

**NOTE:** Place a rag around the throttle cable adjuster to prevent the lubricant splash. Add lubricant until it runs out at carburetor end of the throttle cable. Reinstall and adjust the cable.

### **Throttle Lever Adjustment**

Slide rubber protector back to expose throttle cable adjuster.

Loosen lock nut then turn the adjuster to obtain correct throttle lever free play.

**NOTE:** Measure throttle free play at the tip of throttle lever.

Tighten lock nut and reinstall protector.

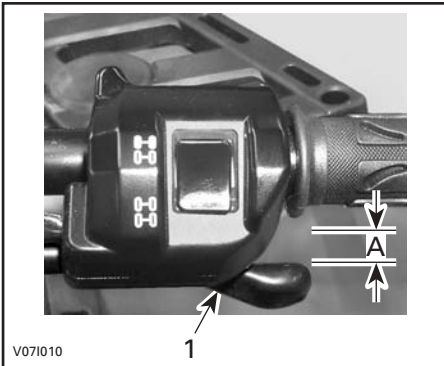

1. Throttle lever  
A. 3 to 6 mm (1/8 to 7/32 in)

With the transmission lever on PARK position, start the engine. Check if the throttle cable is adjusted correctly by turning handlebar fully right then fully left. If the engine RPM increases, readjust the throttle lever free play.

## **Suspension**

### **Lubrication**

Lubricate front A-arms. Use synthetic grease (P/N 293 550 010). There is two grease fittings on each A-arm.

## **Inspection**

### **Front Suspension**

Inspect the McPherson struts for oil leaks or other damages. Check tightness of fasteners. See an authorized Bombardier ATV dealer as necessary.

### **Rear Suspension**

Inspect shock absorber for oil leaks and fasteners for tightness. See an authorized Bombardier ATV dealer as necessary.

### **Trailing arms**

Check trailing arms for distortion, cracks or bending. See an authorized Bombardier ATV dealer if any problem is detected.

### **A-arms**

Check A-arms for cracks, bending or other damages. See an authorized Bombardier ATV dealer as necessary.

## **Adjustment**

### **Rear Shocks**

## **WARNING**

Left and right adjusting cams must always be set at the same position. Never adjust one adjusting cam only. Uneven adjustment can cause poor handling and loss of stability, which could lead to an accident.

### **Preload Adjustment**

Adjust spring preload by turning adjusting cam accordingly with the adjusting wrench in vehicle tool box.

Turn the adjusting cams clockwise for a firmer ride and rough road condition or when carrying cargo or pulling a trailer.

Turn the adjusting cams counterclockwise for a light load and a smooth road condition.

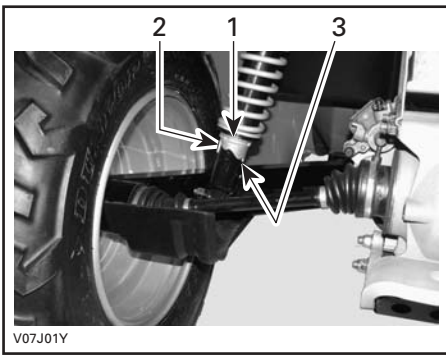

1. *Adjusting cams*
2. *Smooth adjustment*
3. *Hard adjustment*

## Brake

### Front and Rear Brakes

The front and rear brakes are hydraulic disc types. These brakes are self-adjusting and require no adjustment.

The brake lever and the brake pedal require no adjustment.

Check the following to keep the brakes in a good operating condition:

- brake system for fluid leaks
- brake for spongy feel
- brake discs for excessive wear and surface condition
- brake pads for wear, damage or looseness.

SERVICE LIMIT	
Brake pads	1 mm (.040 in)
Front discs	3.5 mm (.138 in)
Rear disc	4.3 mm (.170 in)

## WARNING

The brake fluid replacement or any brake system repairs should be performed by an authorized Bombardier ATV dealer.

## Body/Frame

### Engine Area

Check engine area for any damage and leaks. Ensure all hose clamps are properly secured and no hose is cracked, kinked or otherwise damaged.

Inspect muffler, battery and reservoir fastening devices.

Check electrical connections for corrosion and tightness.

Replace or have damaged parts repaired.

### Hitch/Trailer Ball Condition

Check tightness of fasteners and tightness/condition of trailer ball. Properly retighten as necessary and replace ball if worn.

### Chassis Fasteners

Check fastener condition and tightness on the vehicle. Retighten as required.

### Seat Fasteners

Remove seat and check latch mechanism and pin for wear. See an authorized Bombardier ATV dealer for parts replacement if damaged.

### Vehicle Cleaning and Protection

Never use the high pressure washer to clean the vehicle **USE LOW PRESSURE ONLY (like a garden hose)**. The high pressure can cause electrical or mechanical damages.

Painted parts which are damaged should be properly repainted to prevent rust.

When required, wash the body with hot water and soap (only use mild detergent). Apply non-abrasive wax.

**CAUTION:** Never clean plastic parts with strong detergent, degreasing agent, paint thinner, acetone, etc.

# CARGO AND TRANSPORTATION

While reading this *Operator's Guide*, remember that:

## WARNING

Indicates a potential hazard that, if not avoided, could result in serious injury or death.

## Cargo

## WARNING

The vehicle handling, stability and braking distance are affected when loading racks and using the vehicle. Correct loading and weight distribution are therefore important. Never overload, tow or carry cargo improperly. Always ensure the cargo is safely secured and properly distributed on the rack(s) before operating the vehicle. Safely reduce speed according to terrain conditions when carrying cargo or pulling a trailer. Allow greater distance for braking. Always secure cargo as low as possible on the rack(s) to reduce the effect of a higher center of gravity. Failure to follow the recommendations here could cause changes in vehicle handling which could lead to an accident resulting in severe injuries including the possibility of death. For more information, see the *Safety Handbook*.

When cargoing vehicle, respect these maximum loads.

**TOTAL LOAD ALLOWED: 230 kg (500 lb)**

(includes driver, all other loads and added accessories)

**40 kg (90 lb)**



**80 kg (175 lb)**

Includes rear rack, rear storage box and tongue load



V07A0DL



## Transportation

When transporting a vehicle, secure vehicle to trailer or in pickup box with suitable tie-downs. Using ordinary ropes is not recommended.



Place the fuel valve to OFF position.  
Select the PARK position and set the parking brake.  
Secure the vehicle by the front bumper and rear bumper.

**CAUTION:** Attaching vehicle at other locations may damage the vehicle.

## Front Location



## Rear Location

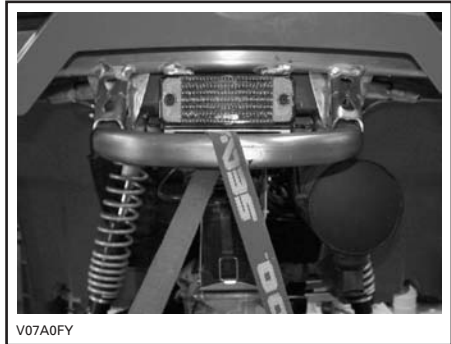

## **WARNING**

Do not tow this vehicle behind a car or other vehicle.



# TROUBLESHOOTING

<b>SYMPTOM: <i>Engine does not turn</i></b>	
<b>POSSIBLE CAUSES</b>	<b>WHAT TO DO</b>
1. Ignition switch is in the OFF position.	Place switch to ON position.
2. Transmission is not set on the PARK or NEUTRAL.	Set transmission either in PARK or in NEUTRAL or press brake lever.
3. Burnt fuse.	Check main fuse condition.
4. Weak battery or loose connections.	Check charging system fuse. Check connections and terminals condition. Have the battery checked. Contact an authorized Bombardier ATV dealer.

<b>SYMPTOM: <i>Engine turns over but fails to start</i></b>	
<b>POSSIBLE CAUSES</b>	<b>WHAT TO DO</b>
1. Burnt fuse.	Check main fuse condition.
2. Mixture not rich enough to start cold engine.	Check fuel tank level and check starting procedure, particularly use of the choke.
3. Flooded engine (spark plug wet when removed).	Refer to SPECIAL PROCEDURES.
4. No fuel to the engine (spark plug dry when removed).	Check fuel tank level; turn fuel valve to ON (also try on RES). A failure of the fuel pump or carburetor may have occurred. Contact an authorized Bombardier ATV dealer.
5. Spark plug/ignition (no spark).	Check main fuse condition. Remove spark plug then reconnect to ignition coil. Check that ignition switch and/or engine stop switch is/are at the ON position. Start engine with spark plug grounded to engine away from spark plug hole. If no spark appears, replace spark plug. If trouble persists, contact an authorized Bombardier ATV dealer.
6. Engine compression.	As the engine is pulled over with the rewind starter, "cycles" of resistance should be felt as piston goes past top dead center. If no pulsating resistance is felt, it suggests a major loss of compression. Contact an authorized Bombardier ATV dealer.

<b>SYMPTOM: <i>Engine lacks acceleration or power</i></b>	
<b>POSSIBLE CAUSES</b>	<b>WHAT TO DO</b>
1. Fouled or damaged spark plug.	Check item ENGINE TURNS OVER BUT FAILS TO START.
2. Lack of fuel to engine.	Check item ENGINE TURNS OVER BUT FAILS TO START.
3. Carburetor adjustments.	Contact an authorized Bombardier ATV dealer.
4. Engine is overheating.	Check ENGINE OVERHEAT in SPECIAL PROCEDURES. If overheating persists, contact an authorized Bombardier ATV dealer.
5. Air filter/box plugged or dirty.	Check air filter and clean if necessary. Check deposits in air box drain. Check the position of the air intake tube.
6. CVT dirty or wear.	Contact an authorized Bombardier ATV dealer.

<b>SYMPTOM: <i>Engine backfire</i></b>	
<b>POSSIBLE CAUSES</b>	<b>WHAT TO DO</b>
1. Exhaust system leakage.	Contact an authorized Bombardier ATV dealer.
2. Engine is running too hot.	See ENGINE LACKS ACCELERATION OR POWER.
3. Ignition timing is incorrect or there is an ignition system failure.	Contact an authorized Bombardier ATV dealer.
4. Improper carburetor setting.	Contact an authorized Bombardier ATV dealer.

<b>SYMPTOM: <i>Engine misfire</i></b>	
<b>POSSIBLE CAUSES</b>	<b>WHAT TO DO</b>
1. Fouled/damaged/worn spark plug.	Clean/verify spark plug and heat range. Replace as required.
2. Water in fuel.	Drain fuel system and refill with fresh fuel.

<b>SYMPTOM: <i>Vehicle cannot reach full speed</i></b>	
<b>POSSIBLE CAUSES</b>	<b>WHAT TO DO</b>
1. Engine.	See ENGINE LACKS ACCELERATION OR POWER.
2. Parking brake.	Ensure brake lever lock is completely removed.
3. Air filter/box plugged or dirty.	Check air filter and clean if necessary. Check deposits in air box drain. Check the position of the air intake tube.
4. CVT dirty or wear.	Contact an authorized Bombardier ATV dealer.

<b>SYMPTOM: <i>Transmission lever is hard to move</i></b>	
<b>POSSIBLE CAUSES</b>	<b>WHAT TO DO</b>
1. Transmission gears are in a position that prevents the transmission lever to work.	Rock the vehicle back and forth to move the gears in the transmission and allow the transmission lever to be set.
2. Engine idle speed is set too high.	Adjust the idle speed. Refer to the SPECIFICATION.
3. CVT dirty or wear.	Contact an authorized Bombardier ATV dealer.

<b>SYMPTOM: <i>The RPM increases but the vehicle doesn't move</i></b>	
<b>POSSIBLE CAUSES</b>	<b>WHAT TO DO</b>
1. The transmission is P or N position.	Select the R, HI or LO position.
2. CVT is defective.	Contact an authorized Bombardier ATV dealer.
3. Water in the CVT housing.	Contact an authorized Bombardier ATV dealer.

# SPECIFICATIONS

VEHICLE MODEL		OUTLANDER™ 400
<b>ENGINE</b>		
Type	BOMBARDIER-ROTAX® 4-TEC, 4-stroke. Over Head Camshaft (OHC), liquid cooled	
Number of cylinder	Single cylinder	
Number of valve	4 valves with mechanical lifters (adjustable)	
Displacement	400 cc (24.4 cu. in)	
Bore	Standard	91 mm (3.58 in)
Stroke	62 mm (2-1/2 in)	
Compression ratio	10:1	
Lubrication	Wet sump with replaceable oil filter (lubrication of engine and transmission simultaneously)	
Decompressor	Automatic	
Exhaust system	Spark arrester approved U.S. Forest Service (USFS)	
Air filter	2 stage foam filter	
<b>TRANSMISSION</b>		
Transmission	Continuously Variable Transmission (CVT)	
<b>COOLING</b>		
Type	Liquid cooled	
Radiator	Front mounted with thermostatic fan	
<b>CARBURATION</b>		
Carburetor make and type	Mikuni BSR33. Constant velocity with manual choke and ECS (Enricher Coasting System)	
Choke plunger position	Variable	
Idle speed	± 100	1300 RPM
Fuel pump make and type	Mikuni, external (vacuum-operated)	

VEHICLE MODEL		OUTLANDER™ 400
<b>ELECTRICAL</b>		
Magneto generator make and type	Denso, 400 W @ 6000 RPM	
Ignition type	CDI (Capacitor Discharge Ignition)	
Ignition timing	Not adjustable	
Engine RPM limiter	8000 RPM (any gear in forward)	
Vehicle speed limiter	15 km/h (9 MPH) in reverse	
Spark plug make and type	NGK DCPR8E	
Number of spark plug	1	
Spark plug gap	0.7 mm (.027 in)	
Battery	12 V, 13 Ah (18 Ah, optional). Dry type battery	
Starting system	Electric start and manual rewind starter. Start on P, R, N, H or L position (with brake applied)	
Headlight	2 x 30 W	
Taillight	8/27 W	
Pilot lamp cluster	LEDS, 0.7 V approx. (each)	
<b>FUSES</b>		
Accessories	15 A (power outlet and auxiliary supply)	
Fan	20 A	
Main	20 A	
Charging system	30 A	
<b>DRIVE TRAIN</b>		
Front differential	Shaft driven/single auto-lock differential (shear pump)	
Rear axle	Shaft driven	
<b>SUSPENSION</b>		
Front	Type	Independent suspension — McPherson type
	Travel	178 mm (7 in)
Rear	Type	Independent suspension — Trailing arms
	Travel	203 mm (8 in)
<b>TIRES</b>		
Pressure	Front	28 kPa (4 PSI) recommended, 24 kPa (3.5 PSI) minimum
	Rear	31 kPa (4.5 PSI) recommended, 28 kPa (4 PSI) minimum
Size	Front	25 x 8 - 12
	Rear	25 x 11 - 12

VEHICLE MODEL		OUTLANDER™ 400
<b>WHEELS</b>		
Size	Front	12 x 6
	Rear	12 x 7.5
Wheel nut torque		70 N•m (52 lbf•ft)
<b>BRAKES</b>		
Front		Hydraulic, 2 discs
Rear		Hydraulic, 1 disc
Parking		Park through transmission. LH brake lever includes a lock
<b>LOADING CAPACITY</b>		
Front rack		40 kg (88 lb)
Rear rack		80 kg (176 lb) includes tongue load
Rear storage box		10 kg (22 lb)
Total vehicle load allowed		227 kg (500 lb) includes driver, all other loads and added accessories
GVWR (Gross Vehicle Weight Rating)		454 kg (1000 lb)
Towing capacity		500 kg (1100 lb)
Tongue capacity		14 kg (30 lb) included with rear box
<b>DIMENSIONS</b>		
Dry mass		263 kg (580 lb)
Overall length		2184 mm (86 in)
Overall width		1168 mm (46 in)
Overall height		1143 mm (45 in)
Seat height		945 mm (37 in)
Wheel base		1244 mm (49 in)
Wheel track	Front	965 mm (38 in)
	Rear	914 mm (36 in)
Turning radius		1829 mm (72 in)
Ground clearance	Front and under engine	236 mm (9.3 in)
	Rear	236 mm (9.3 in)
Weight distribution (front/rear)		49/51%

VEHICLE MODEL		OUTLANDER™ 400
<b>LIQUIDS</b>		
Oil type (engine and transmission)		SAE 5W30, 4-stroke mineral-based engine oil. API classification SG, SH or SJ or Bombardier synthetic oil 5W40. Refer to OIL VISCOSITY CHART for proper grade
Coolant		Ethylene-glycol/water mix (50% coolant, 50% water). Use coolant specifically designed for aluminum engines
Fuel	Type	Regular unleaded gasoline
	Octane	87 (R + M)/2 or higher
Differential	Front and rear	Synthetic polyolester oil 75W90 (API GL-5)
Hydraulic brake		Brake fluid, DOT 4
Propeller shaft joint grease		Shell, Alvania EP-2 only
<b>CAPACITIES</b>		
Fuel tank		16 L (4.2 U.S. gal) including approximately 2 L (0.5 U.S. gal) reserve
Engine/transmission oil		Oil change with filter: 2.8 L (3 U.S. quarts).
Coolant		2.5 L (2.65 U.S. quarts)
Differential	Front	500 mL (17 U.S. oz)
	Rear	300 mL (10 U.S. oz)

Because of our ongoing commitment to product quality and innovation, Bombardier reserves the right, at any time, to make changes in design and specifications and/or to make additions to, or improvements in its products without imposing any obligation upon itself to install them on its products previously manufactured.

# SI\* METRIC INFORMATION GUIDE

BASE UNITS			
DESCRIPTION	UNIT	SYMBOL	
length .....	meter .....	m	
mass .....	kilogram .....	kg	
force .....	newton .....	N	
liquid .....	liter .....	L	
temperature .....	Celsius .....	°C	
pressure .....	kilo pascal .....	kPa	
torque .....	newton-meter .....	N•m	
land velocity .....	kilometer per hour .....	km/h	

PREFIXES			
PREFIX	SYMBOL	MEANING	VALUE
kilo .....	k .....	one thousand .....	1000
centi .....	c .....	one hundredth of .....	0.01
milli .....	m .....	one thousandth of .....	0.001
micro .....	μ .....	one millionth of .....	0.000001

CONVERSION FACTORS			
TO CONVERT	TO ①	MULTIPLY BY	
in .....	mm .....	25.4	
in .....	cm .....	2.54	
in <sup>2</sup> .....	cm <sup>2</sup> .....	6.45	
in <sup>3</sup> .....	cm <sup>3</sup> .....	16.39	
ft .....	m .....	0.3	
oz .....	g .....	28.35	
lb .....	kg .....	0.45	
lbf .....	N .....	4.4	
lbf•in .....	N•m .....	0.11	
lbf•ft .....	N•m .....	1.36	
lbf•ft .....	lbf•in .....	12	
PSI .....	kPa .....	6.89	
imp. oz .....	U.S. oz .....	0.96	
imp. oz .....	mL .....	28.41	
imp. gal .....	U.S. gal .....	1.2	
imp. gal .....	L .....	4.55	
U.S. oz .....	mL .....	29.57	
U.S. gal .....	L .....	3.79	
MPH .....	km/h .....	1.61	
Fahrenheit .....	Celsius .....	(°F - 32) ÷ 1.8	
Celsius .....	Fahrenheit .....	(°C × 1.8) + 32	
hp .....	kW .....	.75	

\* The international system of units abbreviates SI in all languages.

① To obtain the reverse sequence, divide by the given factor. To convert millimeters to inches, divide by 25.4.

NOTE: Conversion factors are rounded off to 2 decimals for easier use.



---

## **PRIVACY OBLIGATIONS/DISCLAIMER**

We wish to inform you that your coordinates will be used for safety and warranty purposes. Sometimes, we also use the coordinates of our clients to inform them about our products and to present them offers. Should you prefer not to receive information on our products, services and offers, please let us know by writing to the address below.

Also note that, from time to time, carefully selected and trustworthy organizations may be permitted to use the coordinates of our clients to promote quality products and services. If you prefer not to have your name and address released, please let us know by writing to the address below:

**Bombardier Inc.**  
**Recreational Products**  
Warranty Department  
75 J.A. Bombardier Street  
Sherbrooke, Québec J1L 1W3  
Canada

Fax Number: (819) 566-3590

---

# CHANGE OF ADDRESS/OWNERSHIP

If your address has changed, be sure to fill out and mail the card provided on this page. Such notification is likewise necessary for your own safety even after expiration of the original warranty, since Bombardier Inc. will be in a position to contact you if correction to your ATV becomes necessary.

**NOTE:** This card is strictly for change of address only.

CHANGE OF ADDRESS

CHANGE OF OWNERSHIP

---

## VEHICLE IDENTIFICATION NUMBER

Model Number

Vehicle Identification Number (V.I.N.)

OLD ADDRESS:

NAME

NO.

STREET

APT

CITY

STATE/PROVINCE

ZIP/POSTAL CODE

COUNTRY

NEW ADDRESS:

NAME

NO.

STREET

APT

CITY

STATE/PROVINCE

ZIP/POSTAL CODE

COUNTRY

## STOLEN UNITS

In the event that your ATV is stolen, you should notify your area's distributor warranty department of such.

Please provide your name, address, phone number, vehicle identification number and date it was stolen.

Bombardier will provide a list of stolen units to all ATV dealers on a monthly basis to aid in recovery of such units to their owners.

AFFIX  
PROPER  
POSTAGE

**BOMBARDIER**  
RECREATIONAL PRODUCTS

WARRANTY DEPARTMENT  
75, J.A. BOMBARDIER ST.  
SHERBROOKE (QUEBEC)  
CANADA J1L 1W3

---

# CHANGE OF ADDRESS/OWNERSHIP

If your address has changed, be sure to fill out and mail the card provided on this page. Such notification is likewise necessary for your own safety even after expiration of the original warranty, since Bombardier Inc. will be in a position to contact you if correction to your ATV becomes necessary.

**NOTE:** This card is strictly for change of address only.

CHANGE OF ADDRESS

CHANGE OF OWNERSHIP

---

## VEHICLE IDENTIFICATION NUMBER

Model Number

Vehicle Identification Number (V.I.N.)

OLD ADDRESS:

NAME

NO.

STREET

APT

CITY

STATE/PROVINCE

ZIP/POSTAL CODE

COUNTRY

NEW ADDRESS:

NAME

NO.

STREET

APT

CITY

STATE/PROVINCE

ZIP/POSTAL CODE

COUNTRY

## STOLEN UNITS

In the event that your ATV is stolen, you should notify your area's distributor warranty department of such.

Please provide your name, address, phone number, vehicle identification number and date it was stolen.

Bombardier will provide a list of stolen units to all ATV dealers on a monthly basis to aid in recovery of such units to their owners.

AFFIX  
PROPER  
POSTAGE

**BOMBARDIER**  
RECREATIONAL PRODUCTS

WARRANTY DEPARTMENT  
75, J.A. BOMBARDIER ST.  
SHERBROOKE (QUEBEC)  
CANADA J1L 1W3

ATV MODEL No. \_\_\_\_\_

**VEHICLE**  
IDENTIFICATION NUMBER (V.I.N.) \_\_\_\_\_

**ENGINE**  
IDENTIFICATION NUMBER (E.I.N.) \_\_\_\_\_

**Owner:**

**Purchase Date** \_\_\_\_\_  
YEAR MONTH DAY

**Warranty Expiry Date** \_\_\_\_\_  
YEAR MONTH DAY

To be completed by the dealer at the time of the sale.

DEALER IMPRINT AREA

**Please verify with your selling dealer to ensure your ATV has been registered with  
Bombardier.**

 **WARNING**

Indicates a potential hazard that, if not avoided, could result in serious injury or death.



 **WARNING**

**THIS VEHICLE CAN BE HAZARDOUS TO OPERATE. YOUR ATV CAN BE HAZARDOUS TO OPERATE.** A collision or rollover can occur quickly, even during routine manoeuvres such as turning and driving on hills or over obstacles, if you fail to take proper precautions.

**SEVERE INJURY OR DEATH** can result if you do not follow these instructions:

- **BEFORE YOU OPERATE THIS ATV, READ THE OPERATOR'S GUIDE, THE SAFETY HANDBOOK AND ALL LABELS.**
- **BEFORE YOU OPERATE THIS ATV, WITHOUT PROPER INSTRUCTION.** Beginners should complete a certified training course.
- **NEVER CARRY A PASSENGER.** You increase your risk of losing control if you carry a passenger.
- **NEVER OPERATE THIS ATV ON A PAVED SURFACE.** You increase your risk of losing control if you operate this ATV on pavement.
- **NEVER OPERATE THIS ATV ON PUBLIC ROADS.** You can collide with another vehicle if you operate this ATV on a public road.
- **ALWAYS WEAR AN APPROVED HELMET,** eye protection and protective clothing.
- **NEVER CONSUME ALCOHOL OR DRUGS** before or while operating this vehicle.
- **NEVER OPERATE THIS ATV AT EXCESSIVE SPEEDS.** You increase your risk of losing control if you operate this ATV at speeds too fast for the terrain, visibility conditions or your experience.
- **NEVER ATTEMPT WHEELIES, JUMPS, OR OTHER STUNTS.**

® ™ TRADEMARKS OF BOMBARDIER INC. OR IT'S SUBSIDIARIES.  
© 2003 BOMBARDIER INC. ALL RIGHTS RESERVED.  
PRINTED IN THE E.U.

**OPERATOR'S GUIDE**  
**OUTLANDER 2003**  
**219 000 239**