

SEA-DOO®



2019 OPERATOR'S GUIDE



Sea-Doo
MOVE Trailer



WARNING

Read this User's Guide.
It contains important safety information.
Keep this User's Guide for reference.

2 1 9 0 0 2 0 3 1

Original Instructions

 **WARNING**

Disregarding any of the safety precautions and instructions contained in this guide and on-product labels could cause injury including the possibility of death!

In Canada, products are distributed by Bombardier Recreational Products Inc. (BRP).

In USA, products are distributed by BRP US Inc.

This is a non-exhaustive list of trademarks that are the property of Bombardier Recreational Products Inc. or its affiliates:

Sea-Doo®

Spark™

INTRODUCTION

Congratulations on your purchase of your new BRP Sea-Doo® MOVE trailer. It is backed by the BRP warranty and a network of authorized Sea-Doo personal watercraft (PWC) dealers ready to provide the parts or service you may require.

Know Before You Go

Read this guide and follow all instructions before installing or using this product.

Read all on-product safety labels carefully and follow the operating procedures described.

Failure to follow the warnings contained in this User's Guide can result in **SERIOUS INJURY** or **DEATH**.

About this User's Guide

The following guide will help you become better acquainted with your new trailer and its safe operation.

Keep this User's Guide in the tow vehicle so you can refer to it.

If you want to view and/or print an extra copy of this User's Guide, simply visit the following website:

www.operatorsguides.brp.com

It is understood that this User's Guide may be translated into another language. In the event of any discrepancy, the English version shall prevail.

The information and components/system descriptions contained in this document are correct at the time of publication. Bombardier Recreational Products Inc., however, maintains a policy of continuous improvement of its products without imposing upon itself any obligation to install them on products previously manufactured. Due to late changes, some differences between the manufactured product and the descriptions and/or specifications in this guide may occur. BRP reserves the right at any time to dis-

continue or change specifications, designs, features or equipment without incurring any obligation upon itself.

The illustrations in this document show the typical construction of the different assemblies and may not reproduce the full detail or exact shape of the parts. However, they represent parts that have the same or similar function.

Safety Messages

The types of safety messages, what they look like and how they are used in this guide are explained as follows:

The safety alert symbol  indicates a **potential injury hazard**.

WARNING

Indicates a potential hazard which, if not avoided, could result in serious injury or death.

 **CAUTION** Indicates a hazard situation which, if not avoided, could result in minor or moderate injury.

NOTICE Indicates an instruction which, if not followed, could severely damage trailer components or other property.

***This page is
intentionally blank***

TABLE OF CONTENTS

INTRODUCTION	1
Know Before You Go	1
About this User's Guide	1
Safety Messages	1

SAFETY INFORMATION

SPECIAL SAFETY MESSAGES	6
Important Warnings	6
Important Information	6
LOCATION OF THE IMPORTANT LABELS	7
Safety Labels (All Models)	7
Technical Information Labels (MOVE I Series)	8
Technical Information Labels (MOVE II Series)	10

OPERATING INSTRUCTIONS

TRAILER SET-UP	14
All Models Except Aluminum and Spark™ MOVE II	14
Aluminum Models	16
Spark™ MOVE II Models	18
BEFORE GETTING UNDERWAY	19
Attaching the Trailer to the Tow Vehicle	19
Pre-Use Inspection	21
TOWING THE TRAILER	22
LAUNCHING THE PERSONAL WATERCRAFT (PWC)	23
LOADING THE PERSONAL WATERCRAFT (PWC)	24

TECHNICAL INFORMATION

TRAILER IDENTIFICATION NUMBER	28
SPECIFICATIONS (MOVE I SERIES)	29
SPECIFICATIONS (MOVE II SERIES)	30
REPORTING SAFETY DEFECTS	31

MAINTENANCE

MAINTENANCE SCHEDULE	34
At Storage	34
At Preseason	34
MAINTENANCE PROCEDURES	35
Tongue Safety Cable	35
Coupler	35

MAINTENANCE PROCEDURES (cont'd)

Tires 35

Wheels 35

Wheel Bearings and Seals 35

Lights 36

Winch 36

Jack 36

Wooden Bunks (if Equipped) 36

Roller Bunks (if Equipped) 36

TRAILER CARE 37

Salt Water Use 37

Trailer Cleaning 37

WARRANTY

**BRP LIMITED WARRANTY USA AND CANADA: 2019 SEA-DOO® MOVE™
PWC TRAILER 40**

CUSTOMER INFORMATION

PRIVACY INFORMATION 46

CONTACT US 47

North America 47

Europe 47

Oceania 47

South America 47

Asia 47

CHANGE OF ADDRESS/OWNERSHIP 48

SAFETY INFORMATION

SPECIAL SAFETY MESSAGES

Important Warnings

Always perform the *PRE-USE INSPECTION* for safe driving.

Always follow guidelines in *TOWING THE TRAILER*.

Maintain your trailer as per the *MAINTENANCE SCHEDULE*.

Make sure to always secure trailer with wheel blocks when not in use.

Important Information

Trailer

This BRP Sea-Doo MOVE™ trailer has been specially designed to carry a PWC.

Hitch

WARNING

The use of a hitch with an insufficient load rating can result in hitch breakdown.

Be sure the hitch ball size matches the coupler size.

Inspect the hitch for wear, corrosion and cracks before coupling. Replace the required components if any of the above conditions is observed.

WARNING

Do not tow whenever a component is defective.

NOTICE The coupling socket should not be allowed to rest on the ground where dirt and sand can enter the socket. This will lead to excessive wear or cause the locking mechanism to jam.

Ensure hitch is tight before coupling the trailer to the vehicle.

WARNING

An improperly coupled trailer can result in a loss of control or serious road hazard. Never use the trailer pre-use inspection is completed.

Tow Vehicle

Some vehicles are not intended to tow a trailer. Make sure your vehicle is designed to tow a trailer and its towing capacity is sufficient.

WARNING

Never tow this trailer with a vehicle not intended for trailer towing or with an insufficient towing capacity.

Accessories and Modifications

We recommend to use replacement parts and accessories from BRP. They've been especially designed for your trailer and manufactured to meet BRP's demanding standards.

Do not make unauthorized modifications, or use accessories that are not approved by BRP. Since these changes have not been tested by BRP, they may increase the risk of accidents or injuries, and they can make the trailer illegal for use.

LOCATION OF THE IMPORTANT LABELS

The following labels are on your trailer. If missing or damaged, they can be replaced free of charge. See an authorized Sea-Doo dealer.

Please read the following labels carefully before using your trailer.

Safety Labels (All Models)



smo2012-006-055_a

MOVE I AND II TRAILERS WITH WINCH

⚠ WARNING

Serious injury or death can result if this trailer is towed before familiarizing yourself with the manufacturer's operation instructions listed below.

Do not exceed the tow vehicle's "tow rating" or exceed the GVWR or GCWR.

219903238

⚠ WARNING

Before towing this trailer check that:

- Coupler hitch and trailer ball are the same size. Coupler is latched. Safety chains are crisscrossed under tongue and attached to towing vehicle.
- All trailer lighting is working correctly. Load is secured to trailer (front and rear). Tongue jack (if trailer is equipped) is retracted.
- Wheel lug bolts are properly tightened. Tires are inflated to pressure indicated on tire.
- Load is within trailer capacity and distributed properly to maintain proper tongue weight.

You are required to comply with local and state requirements regarding brakes, licensing and any additional equipment that may be necessary. Contact your state motor vehicle department for more information.

219 903.238

LABEL 1



smo2012-006-008

LABEL 3

Technical Information Labels (MOVE I Series)

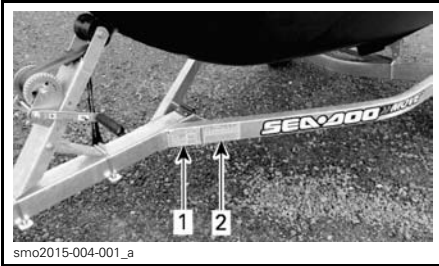

TYPICAL - MOVE I LABELS LOCATION

TIRE AND LOADING INFORMATION RENSEIGNEMENTS SUR LES PNEUS ET LE CHARGEMENT			
The weight of cargo should never exceed Le poids du chargement ne doit jamais dépasser		680 KG or 1500 LB 680 KG ou 1500 LB	
TIRE PNEU	SIZE DIMENSIONS	COLD TIRE PRESSURE PRESSION DES PNEUS A FROID	SEE OWNER'S MANUAL FOR ADDITIONAL INFORMATION
FRONT AVANT	5.30 X 12C	551 kPa 80 PSI	
REAR ARRIERE		0 kPa PSI	VOIR LE MANUEL DE L'USAGER POUR PLUS DE RENSEIGNEMENTS
SPARE DE SECOURS	NONE		

smo2013-005-100

LABEL 1 - MOVE I EXTENDED 1500

TIRE AND LOADING INFORMATION RENSEIGNEMENTS SUR LES PNEUS ET LE CHARGEMENT			
The weight of cargo should never exceed Le poids du chargement ne doit jamais dépasser		522 KG or 1150 LB 522 KG ou 1150 LB	
TIRE PNEU	SIZE DIMENSIONS	COLD TIRE PRESSURE PRESSION DES PNEUS A FROID	SEE OWNER'S MANUAL FOR ADDITIONAL INFORMATION
FRONT AVANT	4.80 X 12B	413 kPa 60 PSI	
REAR ARRIERE		0 kPa PSI	VOIR LE MANUEL DE L'USAGER POUR PLUS DE RENSEIGNEMENTS
SPARE DE SECOURS	NONE		

smo2012-006-004_a

LABEL 1 - MOVE I

TIRE AND LOADING INFORMATION RENSEIGNEMENTS SUR LES PNEUS ET LE CHARGEMENT			
The weight of cargo should never exceed Le poids du chargement ne doit jamais dépasser		680 KG or 1500LB 680 KG ou 1500LB	
TIRE PNEU	SIZE DIMENSIONS	COLD TIRE PRESSURE PRESSION DES PNEUS A FROID	SEE OWNER'S MANUAL FOR ADDITIONAL INFORMATION
FRONT AVANT	ST175/80	241 kPa 35PSI	
REAR ARRIERE		0 kPa PSI	VOIR LE MANUEL DE L'USAGER POUR PLUS DE RENSEIGNEMENTS
SPARE DE SECOURS	NONE		

219400782-017

LABEL 1 - MOVE I SAR

TIRE AND LOADING INFORMATION RENSEIGNEMENTS SUR LES PNEUS ET LE CHARGEMENT			
The weight of cargo should never exceed Le poids du chargement ne doit jamais dépasser		567 KG or 1250 LB 567 KG ou 1250 LB	
TIRE PNEU	SIZE DIMENSIONS	COLD TIRE PRESSURE PRESSION DES PNEUS A FROID	SEE OWNER'S MANUAL FOR ADDITIONAL INFORMATION
FRONT AVANT	4.80 X 12B	413 kPa 60 PSI	
REAR ARRIERE		0 kPa PSI	VOIR LE MANUEL DE L'USAGER POUR PLUS DE RENSEIGNEMENTS
SPARE DE SECOURS	NONE		

smo2014-004-001

LABEL 1 - MOVE I EXTENDED 1250

MFD BY/FABRIQUE PAR: KARAVAN TRAILERS INC.

DATE: June 2011 MADE IN USA JOB# 284645

PNBV / GVWR		ALL AXLES PNBE / GAWR		TIRE/PNEU	COLD INFL. PRESSURE	MAX. LOAD CARRYING CAP		RIM	
KG	LB	KG	LB		KPA	PSI	KG	LB	
671	1479	671	1479	4.80 X 12B	413	60	522	1150	12x4
0									

THIS VEHICLE CONFORMS TO ALL APPLICABLE U.S. FEDERAL MOTOR VEHICLE SAFETY STANDARDS (FMVSS) IN EFFECT ON THE DATE OF MANUFACTURE SHOWN ABOVE. THIS VEHICLE CONFORMS TO ALL APPLICABLE STANDARDS PRESCRIBED UNDER THE CANADIAN MOTOR VEHICLE SAFETY REGULATIONS IN EFFECT ON THE DATE OF MANUFACTURE SHOWN ABOVE. / CE VEHICULE EST CONFORME A TOUTES LES NORMES QUI LUI SONT APPLICABLES EN VERTU DU REGLEMENT SUR LA SECURITE DES VEHICULES AUTOMOBILES DU CANADA EN VIGUEUR A LA DATE DE SA FABRICATION.

TYPE: /TRA/REM WATERCRAFT TRAILER WCE-1250-46

smo2012-006-002

LABEL 2 - MOVE I

MFD BY/FABRIQUE PAR: KARAVAN TRAILERS INC.

DATE: January 2013 MADE IN USA JOB# 350257

PNBV / GVWR		ALL AXLES PNBE / GAWR		TIRE/PNEU	COLD INFL. PRESSURE	MAX. LOAD CARRYING CAP		RIM	
KG	LB	KG	LB		KPA	PSI	KG	LB	
680	1500	680	1500	4.80 X 12B	413	60	567	1250	12x4
0									

THIS VEHICLE CONFORMS TO ALL APPLICABLE U.S. FEDERAL MOTOR VEHICLE SAFETY STANDARDS (FMVSS) IN EFFECT ON THE DATE OF MANUFACTURE SHOWN ABOVE. THIS VEHICLE CONFORMS TO ALL APPLICABLE STANDARDS PRESCRIBED UNDER THE CANADIAN MOTOR VEHICLE SAFETY REGULATIONS IN EFFECT ON THE DATE OF MANUFACTURE SHOWN ABOVE. / CE VEHICULE EST CONFORME A TOUTES LES NORMES QUI LUI SONT APPLICABLES EN VERTU DU REGLEMENT SUR LA SECURITE DES VEHICULES AUTOMOBILES DU CANADA EN VIGUEUR A LA DATE DE SA FABRICATION.

TYPE: /TRA/REM WATERCRAFT TRAILER MOVE I LONG

smo2014-004-004

LABEL 2 - MOVE I EXTENDED 1250

MFD BY/FABRIQUE PAR: KARAVAN TRAILERS INC.

DATE: April 2012 MADE IN USA JOB# 319583

PNBV / GVWR		ALL AXLES PNBE / GAWR		TIRE/PNEU	COLD INFL. PRESSURE	MAX. LOAD CARRYING CAP		RIM	
KG	LB	KG	LB		KPA	PSI	KG	LB	
805	1775	805	1775	5.30 X 12C	551	80	680	1500	12x4
0									

THIS VEHICLE CONFORMS TO ALL APPLICABLE U.S. FEDERAL MOTOR VEHICLE SAFETY STANDARDS (FMVSS) IN EFFECT ON THE DATE OF MANUFACTURE SHOWN ABOVE. THIS VEHICLE CONFORMS TO ALL APPLICABLE STANDARDS PRESCRIBED UNDER THE CANADIAN MOTOR VEHICLE SAFETY REGULATIONS IN EFFECT ON THE DATE OF MANUFACTURE SHOWN ABOVE. / CE VEHICULE EST CONFORME A TOUTES LES NORMES QUI LUI SONT APPLICABLES EN VERTU DU REGLEMENT SUR LA SECURITE DES VEHICULES AUTOMOBILES DU CANADA EN VIGUEUR A LA DATE DE SA FABRICATION.

TYPE: /TRA/REM WATERCRAFT TRAILER WCE-1500-46

smo2013-005-101

LABEL 2 - MOVE I EXTENDED 1500

MFD BY/FABRIQUE PAR: KARAVAN TRAILERS INC.

DATE:		MADE IN USA		JOB#	
PNBV / GVWR		ALL AXLES		COLD INFL. MAX. LOAD	
KG LB		PNBE / GAWR		PRESSURE CARRYING CAI	
		TIRE/PNEU		KPA PSI KG LB RIM	
849 1872		849 1872		ST175/80D13B 241 35 680 1500 13X4.5	

THIS VEHICLE CONFORMS TO ALL APPLICABLE U.S. FEDERAL MOTOR VEHICLE SAFETY STANDARDS (FMVSS) IN EFFECT ON THE DATE OF MANUFACTURE SHOWN ABOVE. THIS VEHICLE CONFORMS TO ALL APPLICABLE STANDARDS PRESCRIBED UNDER THE CANADIAN MOTOR VEHICLE SAFETY REGULATIONS IN EFFECT ON THE DATE OF MANUFACTURE SHOWN ABOVE. / CE VEHICULE EST CONFORME A TOUTES LES NORMES QUI LUI SONT APPLICABLES EN VERTU DU REGLEMENT SUR LA SECURITE DES VEHICULES AUTOMOBILES DU CANADA EN VIGUEUR A LA DATE DE SA FABRICATION.

TYPE: /TRA/REM WATERCRAFT TRAILER WCE-1500-46

219400782-008

LABEL 2 - MOVE I SAR

Technical Information Labels (MOVE II Series)

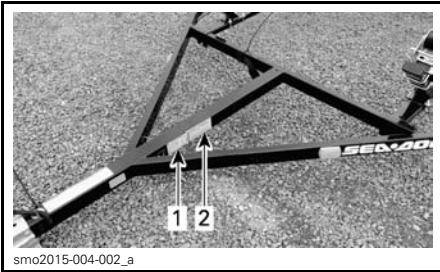

smo2015-004-002_a

TYPICAL - MOVE II LABELS LOCATION

TIRE AND LOADING INFORMATION RENSEIGNEMENTS SUR LES PNEUS ET LE CHARGEMENT			
The weight of cargo should never exceed Le poids du chargement ne doit jamais dépasser			1111 KG or 2450 LB 1111 KG ou 2450 LB
TIRE PNEU	SIZE DIMENSIONS	COLD TIRE PRESSURE PRESSION DES PNEUS A FROID	
FRONT AVANT	ST185/80D13C	345 kPa	50 PSI
REAR ARRIERE		0 kPa	PSI
SPARE DE SECOURS	NONE		

SEE OWNER'S MANUAL FOR ADDITIONAL INFORMATION
VOIR LE MANUEL DE L'USAGER POUR PLUS DE RENSEIGNEMENTS

smo2012-006-005_a

LABEL 1 - MOVE II (EXCEPT SPARK)

TIRE AND LOADING INFORMATION RENSEIGNEMENTS SUR LES PNEUS ET LE CHARGEMENT			
The weight of cargo should never exceed Le poids du chargement ne doit jamais dépasser			553 KG or 1220 LB 553 KG ou 1220 LB
TIRE PNEU	SIZE DIMENSIONS	COLD TIRE PRESSURE PRESSION DES PNEUS A FROID	
FRONT AVANT	4.80 X 12B	413 kPa	60 PSI
REAR ARRIERE		0 kPa	PSI
SPARE DE SECOURS	NONE		

SEE OWNER'S MANUAL FOR ADDITIONAL INFORMATION
VOIR LE MANUEL DE L'USAGER POUR PLUS DE RENSEIGNEMENTS

smo2014-004-002

LABEL 1 - SPARK™ MOVE II

TIRE AND LOADING INFORMATION RENSEIGNEMENTS SUR LES PNEUS ET LE CHARGEMENT			
The weight of cargo should never exceed Le poids du chargement ne doit jamais dépasser			1179 KG or 2600 LB 1179 KG ou 2600 LB
TIRE PNEU	SIZE DIMENSIONS	COLD TIRE PRESSURE PRESSION DES PNEUS A FROID	
FRONT AVANT	ST185/80D13C	345 kPa	50 PSI
REAR ARRIERE		0 kPa	PSI
SPARE DE SECOURS	NONE		

SEE OWNER'S MANUAL FOR ADDITIONAL INFORMATION
VOIR LE MANUEL DE L'USAGER POUR PLUS DE RENSEIGNEMENTS

219001876-051_a

LABEL 1 - MOVE II ALUMINIUM

MFD BY/FABRIQUE PAR: KARAVAN TRAILERS INC.

DATE: April 2013 **MADE IN USA** **JOB#** 360212

ALL AXLES				COLD INFL. MAX. LOAD				
PNBV / GVWR		PNBE / GAWR		TIRE/PNEU		PRESSURE CARRYING CAP.		
KG	LB	KG	LB	KPA	PSI	KG	LB	
708	1560	708	1560	4.80 X 12B	413	60	553	1220 12x4
0								

THIS VEHICLE CONFORMS TO ALL APPLICABLE U.S. FEDERAL MOTOR VEHICLE SAFETY STANDARDS (FMVSS) IN EFFECT ON THE DATE OF MANUFACTURE SHOWN ABOVE. THIS VEHICLE CONFORMS TO ALL APPLICABLE STANDARDS PRESCRIBED UNDER THE CANADIAN MOTOR VEHICLE SAFETY REGULATIONS IN EFFECT ON THE DATE OF MANUFACTURE SHOWN ABOVE. / CE VEHICULE EST CONFORME A TOUTES LES NORMES QUI LUI SONT APPLICABLES EN VERTU DU REGLEMENT SUR LA SECURITE DES VEHICULES AUTOMOBILES DU CANADA EN VIGUEUR A LA DATE DE SA FABRICATION.

TYPE: /TRA/REM WATERCRAFT TRAILER **MOVE II SHORT**

smo2014-004-003

LABEL 2 - SPARK MOVE II

MFD BY/FABRIQUE PAR: KARAVAN TRAILERS INC.

DATE: June 2011 **MADE IN USA** **JOB#** 284649

ALL AXLES				COLD INFL. MAX. LOAD			
PNBV / GVWR		PNBE / GAWR		TIRE/PNEU		PRESSURE CARRYING CAI	
KG	LB	KG	LB	KPA	PSI	KG	LB
1331	2935	1331	2935	ST185/80D13C	345	50	1111 2450 +13x4.5
0							

THIS VEHICLE CONFORMS TO ALL APPLICABLE U.S. FEDERAL MOTOR VEHICLE SAFETY STANDARDS (FMVSS) IN EFFECT ON THE DATE OF MANUFACTURE SHOWN ABOVE. THIS VEHICLE CONFORMS TO ALL APPLICABLE STANDARDS PRESCRIBED UNDER THE CANADIAN MOTOR VEHICLE SAFETY REGULATIONS IN EFFECT ON THE DATE OF MANUFACTURE SHOWN ABOVE. / CE VEHICULE EST CONFORME A TOUTES LES NORMES QUI LUI SONT APPLICABLES EN VERTU DU REGLEMENT SUR LA SECURITE DES VEHICULES AUTOMOBILES DU CANADA EN VIGUEUR A LA DATE DE SA FABRICATION.

TYPE: /TRA/REM WATERCRAFT TRAILER **WC-2450-84**

smo2012-006-003

LABEL 2 - MOVE II (EXCEPT SPARK)

MFD BY/FABRIQUE PAR - KARAVAN TRAILERS INC

DATE: 7/11/2017 **MADE IN USA** **JOB#** 583678

ALL AXLES				COLD INFL. MAX. LOAD			
GVWR / PNBV		GAWR / PNBE		TIRE/PNEU		PRESSURE CARRYING CAP	
KG	LBS	KG	LBS	KPA	PSI	KG	LBS
1343	2960	1343	2960	ST185/80D13C	345	50	1179 2600 13x4.5
0	0				0	0	0

THIS VEHICLE CONFORMS TO ALL APPLICABLE U.S. FEDERAL MOTOR VEHICLE SAFETY STANDARDS (FMVSS) IN EFFECT ON THE DATE OF MANUFACTURE SHOWN ABOVE. THIS VEHICLE CONFORMS TO ALL APPLICABLE STANDARDS PRESCRIBED UNDER THE CANADIAN MOTOR VEHICLE SAFETY REGULATIONS IN EFFECT ON THE DATE OF MANUFACTURE SHOWN ABOVE. / CE VEHICULE EST CONFORME A TOUTES LES NORMES QUI LUI SONT APPLICABLES EN VERTU DU REGLEMENT SUR LA SECURITE DES VEHICULES AUTOMOBILES DU CANADA EN VIGUEUR A LA DATE DE SA FABRICATION.

TYPE: /TRA/REAM WATERCRAFT TRAILER **MOVE II ALUM**

219001876-053_a

LABEL 2 - MOVE II ALUMINIUM

***This page is
intentionally blank***

OPERATING INSTRUCTIONS

TRAILER SET-UP

Do not change the position of the axle.

The bow stopper roller can be moved to change the tongue weight and to suit the shape of the PWC'S bow.

The bunks can be adjusted to suit the shape of the PWC's hull.

All Models Except Aluminum and Spark™ MOVE II

Tongue Weight

Move the winch support towards the front or rear to move the PWC's mass. This changes the weight applied to the tongue.

The tongue weight should be from 3 to 10% of the total trailer and PWC weight with tongue parallel to the ground.

To adjust, loosen the 4 nuts underneath the winch support U-bolts, move winch support to the desired position.

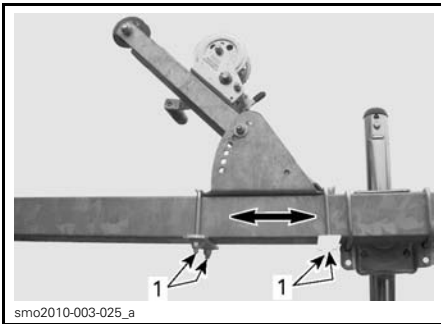

TYPICAL

1. Winch support U-bolts nuts

Tighten bolts to specified torque.

TIGHTENING TORQUE	
Winch support U-bolt nuts	27 N•m ± 3 N•m (20 lbf•ft ± 2 lbf•ft)

Bow Stopper Roller

Set bow roller stopper so that it leans on the PWC bow between rubber bumper and bow eyelet.

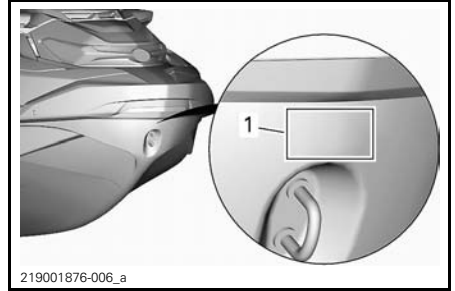

1. Area where the roller must lean

To adjust:

1. Loosen the two (2) nuts underneath the front winch support U-bolt.
2. Remove the winch arm adjustment bolt.
3. Set the bow roller stopper to the desired height, then lock it in position by inserting the bolt through the aligned winch support and winch arm holes.

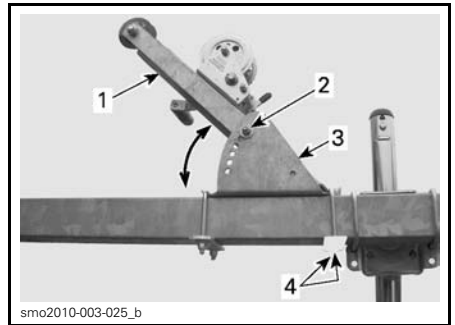

1. Winch arm
2. Winch arm adjustment bolt
3. Winch support
4. Front U-bolt nuts

4. Tighten the fasteners according to the following table.

TIGHTENING TORQUE	
U-bolts nuts	27 N•m ± 3 N•m (20 lbf•ft ± 2 lbf•ft)
Winch arm adjustment bolt	27 N•m ± 3 N•m (20 lbf•ft ± 2 lbf•ft)

Bunks

The bunks (wooden or roller type) must be adjusted according to the shape of the PWC hull. They must rest flat on the flat surfaces of the hull.

Bunk Angle (MOVE I and MOVE II Series)

To adjust the angle:

1. With the PWC off the trailer, loosen the bolts retaining the bunks to their supports.
2. Load the watercraft on the trailer and make sure that the bunks rest flat on a flat part of the hull as shown.

If the bunks do not rest on a suitable part of the hull, refer to appropriate **BUNK HEIGHT AND LATERAL POSITION** section.

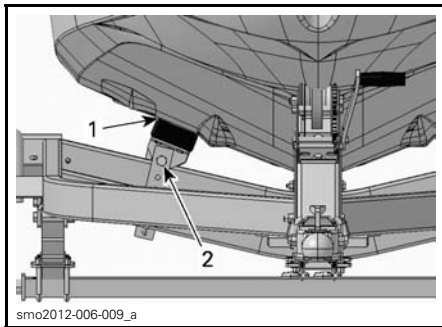

MOVE I - WOODEN BUNK SHOWN

1. Bunk square with hull
2. Bolt

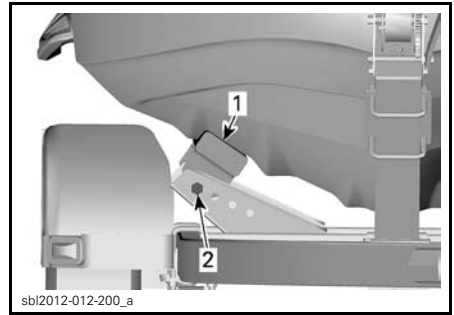

MOVE II - WOODEN BUNK SHOWN

1. Bunk square with hull
2. Bolt

3. Tighten bolts to specified torque.

TIGHTENING TORQUE	
Bunk retaining bolts	21 N•m ± 3 N•m (15 lbf•ft ± 2 lbf•ft)

Bunk Height and Lateral Position (MOVE I Series)

⚠ WARNING

Always set both bunks to the same height and lateral stance.

To change the height and position:

NOTE: The height can be changed at front of the bunks only.

1. Remove the PWC from the trailer.
2. If the height has to be changed, remove the front support U-bolts.
3. Install the U-bolt in the holes corresponding the desired height, but do not tighten yet.

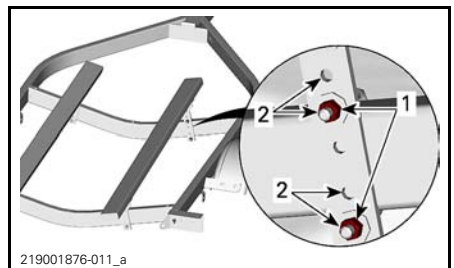

1. U-bolt nuts
2. Mounting holes

- Loosen the rear U-bolt nuts.

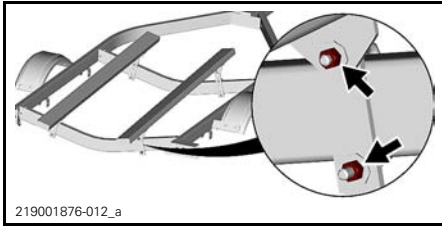

- Move the bunks laterally until desired position is achieved.
- Tighten the nuts to specified torque.

Front Brackets

TIGHTENING TORQUE	
Bunk U-bolts nuts	34 N•m (25 lbf•ft)

Rear Brackets

TIGHTENING TORQUE	
Upper Bunk U-bolts nuts	7 N•m (62 lbf•in)
Lower Bunk U-bolts nuts	34 N•m (25 lbf•ft)

- Adjust the angle if necessary, refer to *BUNK ANGLE*.

Bunk Height and Lateral Position (MOVE II Series)

⚠ WARNING

Always set both bunks to the same height and lateral stance.

To adjust the height and position:

- With the PWC off the trailer, remove the bolts retaining the bunks to their supports.
- Install the bolts in the holes corresponding the desired position.

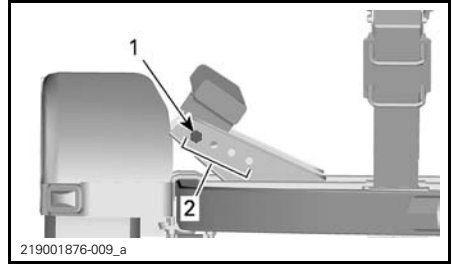

- Bolt
- Adjustment holes

- Tighten the bolts to specified torque.

TIGHTENING TORQUE	
Bunk retaining bolts	21 N•m ± 3 N•m (15 lbf•ft ± 2 lbf•ft)

- Adjust the angle if necessary, refer to *BUNK ANGLE*.

Aluminum Models

Tongue Weight

Move the winch support towards the front or rear to move the PWC's mass. This changes the weight applied to the tongue.

The tongue weight should be from 3 to 10% of the total trailer and PWC weight with tongue parallel to the ground.

To adjust mounting plate position, remove three (3) nuts and washers and slide plate forward or rearward to desired position. If carriage bolts become exposed relocated to a hole below the mounting plate's desired position. Place washers and nuts onto carriage bolts and tighten nuts as per the following table.

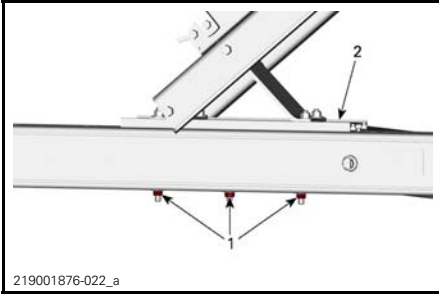

TYPICAL

1. Winch support retaining nuts
2. Mounting plate

TIGHTENING TORQUE	
Winch support retaining nuts	34 N•m (25 lbf•ft)

To adjust front to rear winch position, loosen the six (6) nuts, move forward or rearward to desired position, then tighten nuts as per the following table.

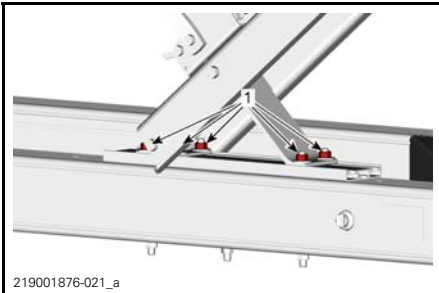

TYPICAL

1. Winch support retaining nuts

TIGHTENING TORQUE	
Winch support retaining nuts	34 N•m (25 lbf•ft)

Bow Stopper Roller

Set bow roller stopper so that it leans on the PWC bow between rubber bumper and bow eyelet (or bow cup on selected models).

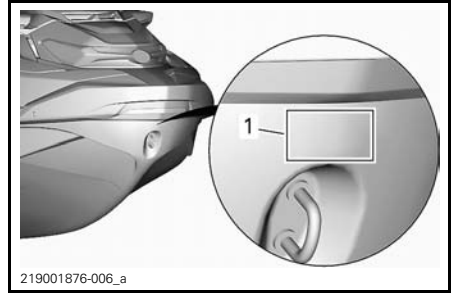

1. Area where the roller must lean

To adjust:

1. Loosen the four (4) winch adjustment nuts as shown.
2. Set the bow roller stopper to the desired height, then lock it in position by tightening nuts as per the following table.

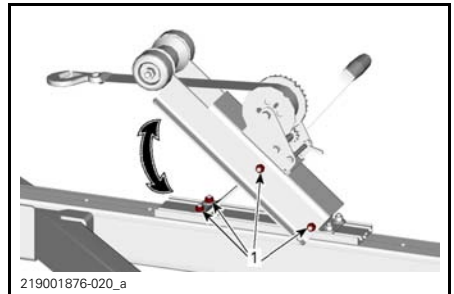

TYPICAL

1. Winch adjustment nuts

TIGHTENING TORQUE	
Winch adjustment nuts	34 N•m (25 lbf•ft)

Bunks

Bunk Angle

To adjust the angle:

1. With the PWC off the trailer, loosen the bolts retaining the bunk to its support.

TRAILER SET-UP

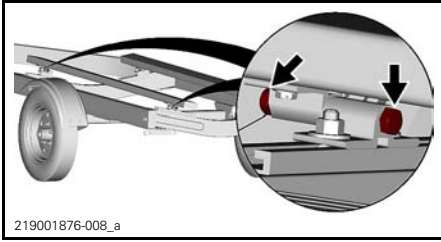

TYPICAL

2. Load the watercraft on the trailer and make sure that the bunks rest flat on a flat part of the hull as shown. If the bunks do not rest on a suitable part of the hull, refer to *BUNK LATERAL POSITION* section.

NOTE: The supports may have a block underneath. The procedure is the same.

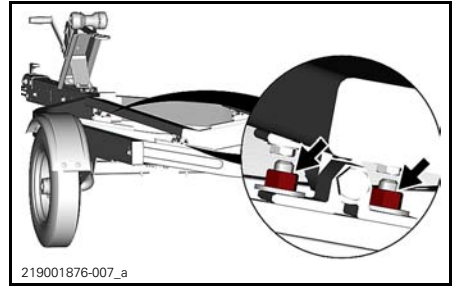

TYPICAL

2. Slide the bunk to the desired position.

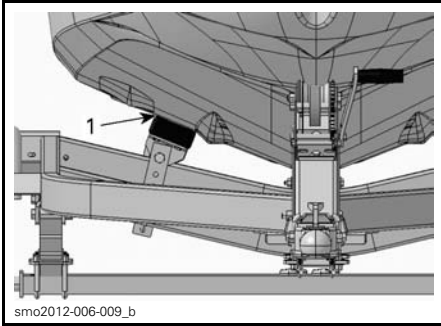

TYPICAL

1. Bunk resting flat

3. Tighten the bolts to specified torque.

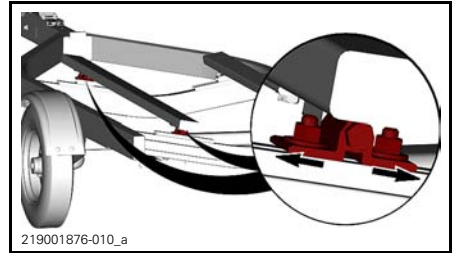

TYPICAL

3. Tighten nuts to specified torque.
4. Adjust the angle if necessary, refer to *BUNK ANGLE*.

TIGHTENING TORQUE	
Bunk retaining bolts	7 N•m (62 lbf•in)

TIGHTENING TORQUE	
Bunk support nuts	41 N•m (30 lbf•ft)

Bunk Lateral Position

⚠ WARNING
Always set both bunks to the same lateral stance.

To adjust the position:

1. With the PWC off the trailer, loosen the nuts on top of the support.

Spark™ MOVE II Models

This trailer is specifically made to transport the Spark PWC. No adjustment is required.

NOTICE Do not use this trailer to transport any other model of PWC. Use this trailer only to transport the Spark models.

BEFORE GETTING UNDERWAY

Attaching the Trailer to the Tow Vehicle

1. Make sure that the coupler and hitch ball are the same size (2 in).
2. Have someone guiding you and back the tow vehicle as close as possible to the trailer. This is easier and safer than pulling the trailer to the vehicle.
3. Be sure the coupler-locking mechanism is released.
4. Raise the front end of the trailer. Position the coupler directly over the hitch ball and lower until it is all the way down.

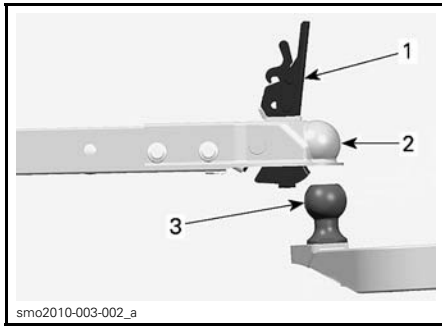

- TYPICAL**
1. Coupler-locking mechanism (released)
 2. Coupler
 3. Hitch ball

5. Check under the coupling to be certain that the ball clamp is below the ball and not riding on top of the ball.

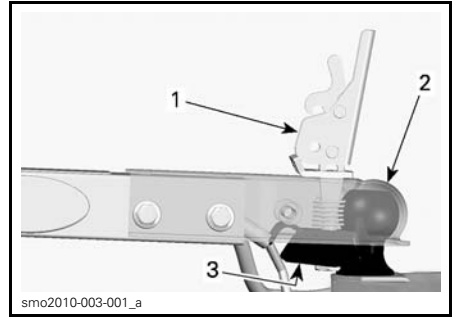

- TYPICAL**
1. Coupler-locking mechanism (released)
 2. Hitch ball in coupler
 3. Ball clamp

6. Close the coupler on the hitch ball.
7. Lift the trailer tongue. If it comes loose from the ball, open the coupler, make sure the clamp is positioned correctly, the close it again.

⚠ WARNING

If the coupler cannot be secured to hitch ball, do not tow the trailer. Refer to an authorized Sea-Doo dealer to inspect the trailer as soon as possible.

8. Lock the coupler using a locking pin.

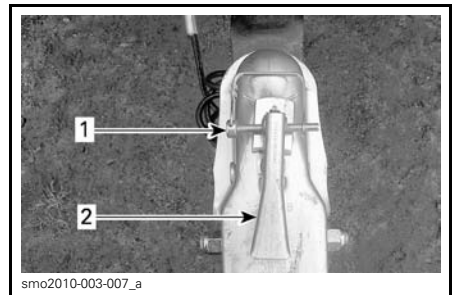

- TYPICAL**
1. Locking pin
 2. Coupler-locking mechanism in locked position

NOTE: At this point the tow vehicle and the trailer should be level.

9. Attach the tongue safety cables in a crisscross pattern as shown.

NOTICE To avoid damaging wiring harness, ensure the harness is not passed between the tongue safety cables.

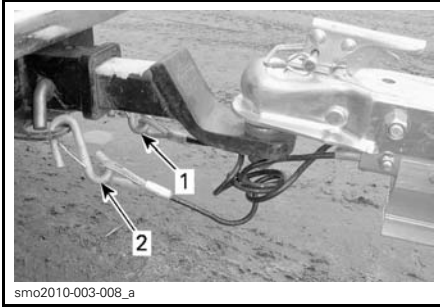

1. LH tongue safety cable attached to the RH side of hitch
2. RH tongue safety cable attached to the LH side of hitch

10. Connect lights connector.

Pre-Use Inspection

WARNING

Perform a pre-use inspection before each use to detect potential problems during operation. The pre-use inspection can help you monitor wear and deterioration before they become a problem. Correct any problems that you discover to reduce the risk of a breakdown or crash. See an authorized Sea-Doo dealer as necessary.

ACTION	✓
Make sure the hitch ball size matches the coupler size (5 cm (2 in)).	
Check that the PWC is ready to be towed according to the PWC manufacturer's recommendations.	
Check that the jack is retracted.	
Check tires condition. Refer to <i>MAINTENANCE PROCEDURES</i> for details.	
Check tires pressure. Refer to <i>SPECIFICATIONS</i> for values.	
Check of wheel lug nuts for tightness.	
Check that the load meets the specifications.	
Check that coupler is latched and locked. Refer to <i>ATTACHING THE TRAILER TO THE TOW VEHICLE</i> .	
Check that tongue safety cables are crisscrossed under the tongue and attached to the hitch. Refer to <i>ATTACHING THE TRAILER TO THE TOW VEHICLE</i> .	
Check lights operation.	
Clean all reflectors and lights lenses.	
Check if PWC is properly secured to the trailer at rear.	
Make sure the PWC is properly secured at front. Refer to <i>LOADING THE PERSONAL WATERCRAFT (PWC)</i>	

TOWING THE TRAILER

Follow the tow vehicle's manufacturer instructions regarding trailer towing.

SEVERE INJURY OR DEATH can result if you do not follow these instructions:

When towing the trailer, pay particular attention to the following:

- Maintain a safe distance between the vehicle ahead and your vehicle.
- When towing a trailer, more time and distance are needed when passing or stopping.
- Reduce your speed and slow down more than usual before turning. Avoid sharp turns.
- When cornering, do it on a larger radius. It takes more space to turn with a trailer.
- Always move slowly when backing up. Ask someone to guide you when possible. Practice in an open area at the first opportunity.
- If trailer starts to sway, do not hit the brakes or compensate using the steering wheel. Reduce speed and maintain a steady course.
- When going downhill, reduce speed before starting the descent. Do not brake continuously. Apply and release brakes alternately to prevent brakes from overheating.

Loss of control of the trailer or trailer/vehicle combination can result in serious injury or death. The most common causes of loss of control of the trailer are:

- Driving too fast for the conditions.
- Overloading the trailer or loading the trailer incorrectly.
- Trailer improperly coupled to the hitch.
- Inadequate towing hitch.
- Not maintaining proper tire pressure.
- Not keeping wheel lug nuts tight.

LAUNCHING THE PERSONAL WATERCRAFT (PWC)

1. Prepare the PWC for launching according to the PWC manufacturer's recommendations.
2. Remove tie-downs from stern and trailer eyelets.
3. Disconnect lights connector.
4. Make sure the way is clear behind the trailer (in and out of water).
5. Attach ropes to the PWC mooring cleats and prevent them from hanging.
6. Have someone guiding you and back the vehicle until trailer reaches the desired depth into water.

NOTE: The PWC must not float above the bunks.

7. Hold the winch handle firmly and set winch mechanism to "unwind".

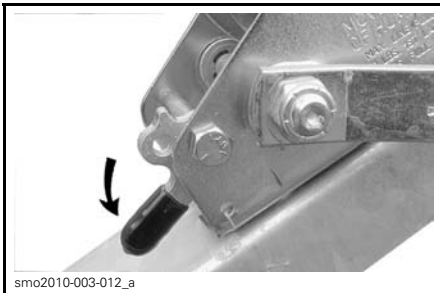

SET WINCH TO "UNWIND"

8. Unwind until PWC slides off the trailer and floats. It may be necessary to push the PWC a little.
9. Grab the ropes previously attached to the mooring cleats.
10. Detach the PWC from the winch strap.
11. Moor the PWC.
12. Drive the tow vehicle out of the ramp.
13. Connect lights connector.

LOADING THE PERSONAL WATERCRAFT (PWC)

1. Disconnect lights connector.
2. Have someone guiding you and back the vehicle until the trailer reaches the desired depth into water.

NOTE: Bunks should be immersed in water just enough for the PWC to be dragged onto them without floating over them.

3. Unwind the winch strap to the appropriate length.
4. Align the PWC with the trailer bunks.
5. Attach the winch strap to the PWC's bow eyelet.
 - 5.1 Pass the small strap through the bow eyelet.
 - 5.2 Hook the small strap securely.

6. Set winch mechanism to "wind", then wind until PWC bow reaches the trailer bow stop roller.

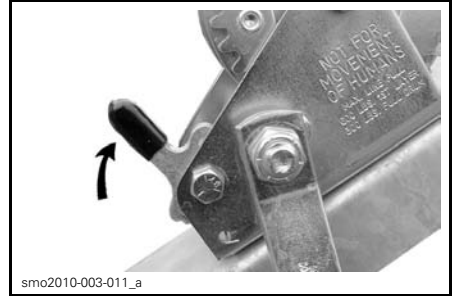

smo2010-003-011_a

SET WINCH TO "WIND"

7. Drive the tow vehicle out of the ramp.
8. Secure PWC on the trailer using suitable tie-downs attached to the stern eyelets and trailer eyelets together.



219001876-002_a

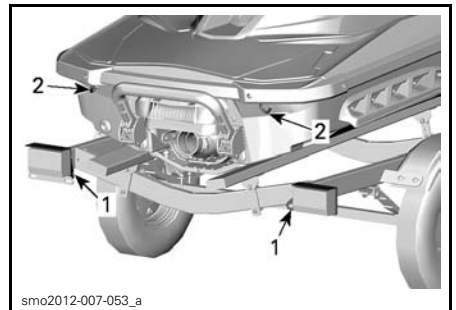

smo2012-007-053_a

TYPICAL - MOVE 1 (EXCEPT ALUMINUM)

1. Trailer eyelets
2. PWC eyelets



219001876-003

SMALL STRAP HOOKED

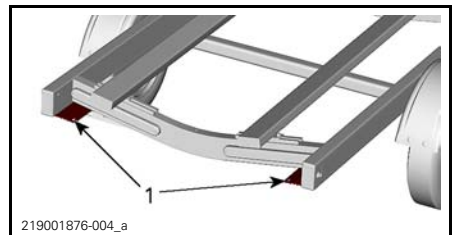

219001876-004_a

TYPICAL - MOVE 1 (ALUMINUM)

1. Trailer eyelets

NOTICE Attach the strap as explained. Using another method may damage to the PWC.

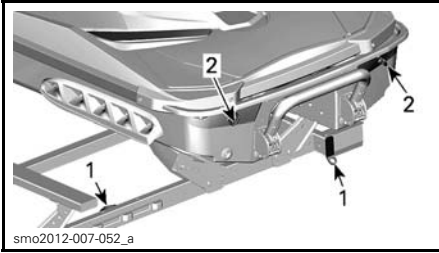

TYPICAL - MOVE II (EXCEPT ALUMINUM)

- 1. Trailer eyelets
- 2. PWC eyelets

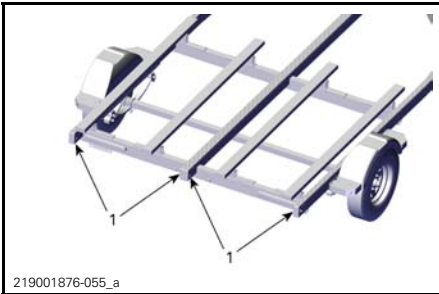

TYPICAL - MOVE II (ALUMINUM)

- 1. Trailer eyelets

9. Connect lights connector.

***This page is
intentionally blank***

TECHNICAL INFORMATION

TRAILER IDENTIFICATION NUMBER

The trailer is identified by a serial number. It may sometimes become necessary to locate this number for warranty purposes or to trace the trailer in the event of theft. The serial number is located on the Technical Information label and is also engraved on the tongue of the trailer.

5K7WS1419CF002080

MFD BY/FABRIQUE PAR: KARAVAN TRAILERS INC.

DATE: June 2011 MADE IN USA JOB# 284645

PNBV / GVWR		PNBE / GAWR		TIRE/PNEU	COLD INFL. PRESSURE		MAX. LOAD CARRYING CAP		
KG	LB	KG	LB		KPA	PSI	KG	LB	RIM
671	1479	671	1479	4.80 X 12B	413	60	522	1150	12x4
0									

THIS VEHICLE CONFORMS TO ALL APPLICABLE U.S. FEDERAL MOTOR VEHICLE SAFETY STANDARDS (FMVSS) IN EFFECT ON THE DATE OF MANUFACTURE SHOWN ABOVE. THIS VEHICLE CONFORMS TO ALL APPLICABLE STANDARDS PRESCRIBED UNDER THE CANADIAN MOTOR VEHICLE SAFETY REGULATIONS IN EFFECT ON THE DATE OF MANUFACTURE SHOWN ABOVE. / CE VEHICULE EST CONFORME A TOUTES LES NORMES QUI LUI SONT APPLICABLES EN VERTU DU REGLEMENT SUR LA SECURITE DES VEHICULES AUTOMOBILES DU CANADA EN VIGUEUR A LA DATE DE SA FABRICATION.

TYPE: /TRA/REM WATERCRAFT TRAILER WCE-1250-46

smo2012-006-002_a

1. Serial number

SPECIFICATIONS (MOVE I SERIES)

MODEL	MOVE I EXTENDED 1250 GALVANIZED/ PAINTED BLACK	MOVE I EXTENDED 1250 ALUMINUM	MOVE I EXTENDED 1500	MOVE I	MOVE I SAR
SUSPENSION					
Type	Leaf spring	Torsion	Leaf spring	Torsion and leaf spring	Torsion
DIMENSIONS					
Overall length	4.1 m (13.5 ft)	4.35 m (14.3 ft)	4.1 m (13.5 ft)	3.8 m (12.5 ft)	4.1 m (13.5 ft)
Overall width	1.5 m (4.9 ft)	1.52 m (5 ft)	1.7 m (5.5 ft)	1.5 m (4.9 ft)	1.7 m (5.5 ft)
Width between fenders ⁽¹⁾	1.2 m (3.9 ft)	1.22 m (4 ft)	1.2 m (3.9 ft)	1.2 m (3.9 ft)	1.2 m (3.9 ft)
Overall height (fender) ⁽²⁾	61 cm (24 in)	56 cm (22 in)	70 cm (27.5 in)	61 cm (24 in)	N.A.
Overall height (winch) ⁽³⁾	80 cm (31 in)	84 cm (33 in)	80 cm (31 in)	80 cm (31 in)	87 cm (34 in)
Coupler ball size	5 cm (2 in)				
WEIGHT AND LOAD LIMITS					
Approximate dry weight	113 kg (250 lb)	97 kg (214 lb)	125 kg (275 lb)	105 kg (231 lb)	125 kg (275 lb)
Carrying capacity	567 kg (1,250 lb)	567 kg (1,250 lb)	682 kg (1,500 lb)	560 kg (1,235 lb)	682 kg (1,500 lb)
TIRES AND WHEELS					
Tire size	4.8 x 12B (in)	4.8 x 12B (in)	5.3 x 12C (in)	4.8 x 12B (in)	ST175/80D13B
Wheel size	4.8 x 12B (in)	4.8 x 12B (in)	5.3 x 12C (in)	4.8 x 12B (in)	4.5 x 13
Cold pressure	413 kPa (60 PSI)	413 kPa (60 PSI)	550 kPa (80 PSI)	413 kPa (60 PSI)	241 kPa (35 PSI)
Lug nuts torque	116 N•m ± 6 N•m (86 lbf•ft ± 4 lbf•ft)				
Minimum thread depth	1.6 mm (1/16 in)				
(1) Maximum PWC width (2) Tongue on the ground (3) Hitch coupler 41 cm (16 in) above the ground N.A.: Not Available					

SPECIFICATIONS (MOVE II SERIES)

MODEL	MOVE II	MOVE II ALUMINUM	SPARK™ MOVE II
SUSPENSION			
Type	Leaf spring		
DIMENSIONS			
Overall length	5.18 m (17 ft)	4.63 m (15.2 ft)	3.78 m (12.5 ft)
Overall width	2.5 m (8.2 ft)	2.6 m (8.5 ft)	2.6 m (8.5 ft)
Width between fenders ⁽¹⁾	2.1 m (6.9 ft)	2.23 m (7 ft)	2.23 m (7 ft)
Overall height (fender) ⁽²⁾	74 cm (29 in)	68.6 cm (27 in)	60 cm (24 in)
Overall height (winch) ⁽³⁾	99 cm (39 in)	78.7 cm (31 in)	87 cm (34 in)
Coupler	5 cm (2 in)		
WEIGHT AND LOAD LIMITS			
Approximate dry weight	220 kg (485 lb)	158 kg (348 lb)	154 kg (340 lb)
Carrying capacity	1 114 kg (2,456 lb)	1 134 kg (2,500 lb)	553 kg (1,220 lb)
TIRES AND WHEELS			
Tire size	ST185/80D13C	ST185/80D13C	4.80 X 12B (in)
Wheel size	ST175/80D13 5H	ST185/80D13C	4.80 X 12B (in)
Cold pressure	345 kPa (50 PSI)	345 kPa (50 PSI)	413 kPa (60 PSI)
Lug nuts torque	116 N•m ± 6 N•m (86 lbf•ft ± 4 lbf•ft)		
Minimum thread depth	1.6 mm (1/16 in)		
(1) Maximum PWC width (2) Tongue on the ground (3) Hitch coupler 41 cm (16 in) above the ground N.A.: Not Available			

REPORTING SAFETY DEFECTS

Your safety is very important to Bombardier Recreational Products Inc. (BRP). If you have any concerns you should immediately contact BRP's customer service.

In the USA, if you believe that your vehicle has a defect which could cause a crash or could cause injury or death, you should immediately inform the National Highway Traffic Safety Administration (NHTSA) in addition to notifying Bombardier Recreational Products Inc.

If NHTSA receives similar complaints, it may open an investigation, and if it finds that a safety defect exists in a group of vehicles, it may order a recall and remedy campaign. However, NHTSA cannot become involved in any individual problems between you, your dealer or Bombardier Recreational Products Inc.

To contact NHTSA:

By phone: Safety Hotline toll-free:
1 888-327-4236 (TTY: 1 800-424-9153)

By E-mail: www.safercar.gov

By mail: Administrator
NHTSA
400 7th Street SW
Washington, DC 20590

You can also obtain other information about motor vehicle safety from the website:
www.safercar.gov

***This page is
intentionally blank***

MAINTENANCE

MAINTENANCE SCHEDULE

Maintenance is very important for keeping your trailer in safe operating condition.

The maintenance schedule does not exempt the pre-use inspection.

NOTE: If trailer is used all year round, carry out both *STORAGE* and *PRE-SEASON* maintenance operations once a year.

At Storage

Carry out the following at trailer storage:

- Inflate tires to recommended pressure.
- Check coupler condition and lubricate.
- Lubricate jack.
- Apply DIELECTRIC GREASE (P/N 293 550 004) in all electric connectors and light bulb socket to prevent corrosion.
- Trailers with winch: Check winch and strap condition. Lubricate winch mechanism.
- If possible, park trailer in a protected area, garage, carport, etc.
- Raise trailer and place blocks under trailer frame to take most of the weight off the suspension and tires.

At Preseason

Carry out the following before using trailer after a storage period:

- Inspect wheels for damage.
- Check tightness of all fasteners.
- Check wheel bearing and seals.
- Check wiring harness and connector condition.
- Inspect tongue safety cables.

MAINTENANCE PROCEDURES

This section includes instructions for basic maintenance procedures. If you have the necessary mechanical skills and the required tools, you can perform these procedures. If not, see your authorized Sea-Doo dealer.

WARNING

Torque wrench tightening specifications must be strictly adhered to.

Locking devices, when removed (e.g.: locking tabs, elastic stop nuts, cotter pins, etc.), must be replaced.

Hoses, cables or locking ties removed during a procedure must be reinstalled as per factory standards.

Tongue Safety Cable

Tongue Safety Cable Inspection

Inspect for damage.

Discontinue use and contact an authorized Sea-Doo dealer if cable or its liner damage is found.

WARNING

Do not use the trailer if safety cables are damaged.

Coupler

Coupler Inspection and Lubrication

Check locking mechanism operation.

Check ball socket, ball clamp and lock mechanism for wear or damage.

Apply a thin coat of multipurpose grease to the inner surface of the ball socket.

Apply light oil to the pivot and sliding surface of the lock mechanism.

Tires

Tire Pressure

Check tire pressure. Tire pressure must be checked while the tire is cold.

NOTE: Do not check the tire pressure immediately after towing the trailer. Allow at least three hours for a tire to cool down, if the trailer has been towed for as much as 1.6 km (1 mi).

The required pressure varies according to the trailer model. Refer to *SPECIFICATIONS*.

Tire Inspection

Replace the tire before towing the trailer if the tire tread has less than 1.6 mm (1/16 in) depth or if the built-in wear indicator bars are visible and flush with the remainder of the tire tread.

Always replace a tire with one of the same dimensions and load limit.

Inspect both sidewalls of each tire for any bubble, cut or bulge; and replace a damaged tire before towing the trailer.

WARNING

A bubble, cut or bulge in the sidewall can result in a tire blowout and loss of control.

Wheels

Wheel Inspection

Check wheel for cracks, bumps or other damages. Replace wheel as required.

Wheel Bearings and Seals

Wheel Bearing Inspection

Install a jack under the axle and raise until the tire gets off the ground.

Push and pull the wheel from the upper edge to feel the play and rotate wheel.

If any play is felt or if wheel does not turn smoothly, have the wheel bearing replaced.

Wheel Bearing Seal Inspection

A slight film of grease around the seal is normal. Have the seal replaced if an excessive leak or damage is noticed.

Lights

All the lights are built with LEDs (light emitting diode) and this technology proved to be reliable. In the unlikely event they do not work, have them checked by an authorized Sea-Doo dealer.

Winch

Winch Inspection

Inspect gears, bushings and strap for wear or damage.

Winch Lubrication

Apply a thin coat of multipurpose grease to the gearing teeth and pivot points. Rotate handle to distribute grease evenly.

Lubricate ratchet pivot point with light oil.

Jack

Jack Lubrication

Clean grease fitting, then lubricate using multipurpose grease. Rotate handle to distribute grease evenly.

Lubricate handle pivot point and wheel axle with light oil. Wipe excess oil and rotate parts to distribute oil evenly.

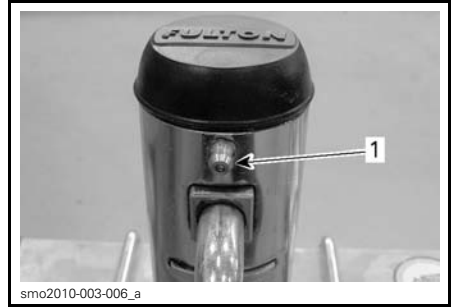

1. Grease fitting

Wooden Bunks (if Equipped)

Check wooden bunks carpet condition and wood hardness.

Roller Bunks (if Equipped)

Check rollers for wear, cracks or damage.

TRAILER CARE

Salt Water Use

If trailer used in salt water, thoroughly rinse trailer daily with fresh water.

Trailer Cleaning

1. Rinse the trailer thoroughly with fresh water to remove loose dirt.
2. Using a soft, clean cloth, wash the trailer with water mixed with a mild detergent, such as soap specially formulated for motorcycles or automobiles.
3. While washing the trailer, check for grease or oil. An automotive grease remover can be used. Thoroughly follow the manufacturer's instructions.
4. Dry the trailer with a chamois or a soft towel.

 **CAUTION** Never use any kind of vinyl or plastic protector on the walk pads as they would get slippery.

***This page is
intentionally blank***

WARRANTY

BRP LIMITED WARRANTY USA AND CANADA: 2019 SEA-DOO® MOVE™ PWC TRAILER

1. SCOPE OF THE LIMITED WARRANTY

Bombardier Recreational Products Inc. ("BRP")™* warrants its 2019 Sea-Doo MOVE™ PWC trailer ("Trailer") sold by authorized Sea-Doo Dealers (as defined hereinafter) in the fifty United States and in Canada from defects in material or workmanship for the period and under the conditions described below. This limited warranty will become null and void if the Trailer has been altered or modified in such a way so as to adversely affect its operation, performance or durability, or has been altered or modified to change its intended use.

2. LIMITATIONS OF LIABILITY

THIS WARRANTY IS EXPRESSLY GIVEN AND ACCEPTED IN LIEU OF ANY AND ALL OTHER WARRANTIES, EXPRESSED OR IMPLIED, INCLUDING WITHOUT LIMITATION ANY WARRANTY OF MERCHANTABILITY OR FITNESS FOR A PARTICULAR PURPOSE. TO THE EXTENT THAT THEY CANNOT BE DISCLAIMED, THE IMPLIED WARRANTIES ARE LIMITED IN DURATION TO THE LIFE OF THE EXPRESS WARRANTY. INCIDENTAL AND CONSEQUENTIAL DAMAGES ARE EXCLUDED FROM COVERAGE UNDER THIS WARRANTY. SOME STATES/PROVINCES DO NOT ALLOW FOR THE DISCLAIMERS, LIMITATIONS AND EXCLUSIONS IDENTIFIED ABOVE, AS A RESULT, THEY MAY NOT APPLY TO YOU. THIS WARRANTY GIVES YOU SPECIFIC RIGHTS, AND YOU MAY ALSO HAVE OTHER LEGAL RIGHTS WHICH MAY VARY FROM STATE TO STATE, OR PROVINCE TO PROVINCE.

Neither the distributor, any Sea-Doo Dealer nor any other person has been authorized to make any affirmation, representation or warranty regarding the Trailer, other than those contained in this limited warranty, and if made, shall not be enforceable against BRP. BRP reserves the right to modify this warranty at any time, being understood that such modification will not alter the warranty conditions applicable to the Trailer sold while this warranty is in effect.

3. EXCLUSIONS – ARE NOT WARRANTED

The following are not warranted under any circumstances:

- Replacement of routine maintenance items including the performance of adjustments.
- Normal wear and tear.
- Damages related to the appearance of the Trailer, including without limitation scratches, dents, fading, flaking, and peeling.
- Damage caused by failure to provide proper maintenance or storage, as described in the Operator's Guide.
- Damage resulting from removal of parts, improper repairs, improper service or improper maintenance, modifications, alterations that are outside of the original specifications of the Trailer, or damage resulting from repairs done by a person that is not an authorized servicing Sea-Doo Dealer.
- Damage resulting from the installation of parts with specifications that differ from the original Trailer parts, such as, without limitation, different tires or wheels.
- Damage resulting from abuse, abnormal use, or neglect.

- Damage resulting from accident, road hazards, submersion, fire, theft, vandalism or any act of God.
- Damage resulting from corrosion from road salts, environmental influences or treatment contrary to the Operator’s Guide.
- Incidental or consequential damages, including without limitation towing, storage, telephone, rental, taxi, inconvenience, insurance coverage, loan payments, loss of time, loss of income.
- Any cost of transportation or shipping incurred in respect of the performance of this warranty.

4. WARRANTY COVERAGE PERIOD

This warranty will be in effect from the date of delivery to the first retail consumer or the date the Trailer is first put into use, whichever occurs first and for the following periods:

1. **TWELVE (12) CONSECUTIVE MONTHS** for private, recreational use, except that the frame is covered for **SIXTY (60) CONSECUTIVE MONTHS**;
2. **FOUR (4) CONSECUTIVE MONTHS** for commercial use, except that the frame is covered for **TWELVE (12) CONSECUTIVE MONTHS**.

A Trailer is used commercially when it is used in connection with any work or employment that generates income, during any part of the warranty period. A Trailer is also used commercially when, at any point during the warranty period, it is licensed for commercial use.

The repair or replacement of parts or the performance of service under this warranty does not extend the life of this warranty beyond its original expiration date.

5. CONDITIONS REQUIRED FOR WARRANTY COVERAGE

- The Trailer must be purchased as new and unused by its first owner from a Sea-Doo dealer authorized to distribute Trailers in the country in which the sale occurred (“Sea-Doo Dealer”).
- The BRP specified pre-delivery inspection process must be completed, documented and signed by the purchaser.
- The Trailer must have undergone proper warranty registration by an authorized Sea-Doo Dealer.
- The Trailer must be purchased in the country in which the purchaser resides.
- Routine maintenance must be performed as indicated in the Operator’s Guide. BRP reserves the right to make warranty coverage contingent upon proof of proper maintenance.

BRP will not honor this limited warranty to any private use owner or commercial use owner if one of the preceding conditions has not been met. Such limitations are necessary in order to allow BRP to preserve both the safety of its products, and also that of its consumers and the general public.

6. WHAT TO DO TO OBTAIN WARRANTY COVERAGE

The customer must cease using the Trailer upon the appearance of an anomaly. The customer must notify a servicing Sea-Doo Dealer within three (3) days of the appearance of a defect, and provide it with reasonable access to the product and reasonable opportunity to repair it. The customer must also present to the

authorized Sea-Doo Dealer proof of purchase of the product and must sign the repair/work order prior to starting the repair in order to validate the warranty repair. All parts replaced under this limited warranty become the property of BRP.

7. WHAT BRP WILL DO

BRP's obligations under this warranty are limited to, at its sole discretion, repairing parts found defective under normal use, maintenance and service, or replacing such parts with new genuine Trailer parts without charge for parts and labor, at any authorized Sea-Doo Dealer during the warranty coverage period. No claim of breach of warranty shall be cause for cancellation or rescission of the sale of the Trailer to the owner.

In the event that service is required outside of the country of original sale, the owner will bear responsibility for any additional charges due to local practices and conditions, such as, but not limited to, freight, insurance, taxes, license fees, import duties, and any and all other financial charges, including those levied by governments, states, territories and their respective agencies.

BRP reserves the right to improve or modify products from time to time without assuming any obligation to modify any products previously manufactured.

8. TRANSFER

If the ownership of a product is transferred during the warranty coverage period, this limited warranty, subject to its terms and conditions, shall also be transferred and be valid for the remaining coverage period provided BRP or an authorized Sea-Doo Distributor/Dealer receives a proof that the former owner agreed to the transfer of ownership, in addition to the co-ordinates of the new owner.

9. CONSUMER ASSISTANCE

In the event of a controversy or a dispute in connection with this limited warranty, BRP suggests that you try to resolve the issue at the dealership level. We recommend discussing the issue with the authorized Sea-Doo Dealer's service manager or owner.

If the matter still remains unresolved, contact BRP by filling out the customer contact form at www.brp.com or contact BRP by mail at one of the addresses listed under the *CONTACT US* section of this guide.

- * In the USA, products are distributed and serviced by BRP US Inc.
- © 2018 Bombardier Recreational Products Inc. All rights reserved.
- ™ Trademarks of Bombardier Recreational Products Inc. or its affiliates.
- ® Registered trademarks of Bombardier Recreational Products Inc.

***This page is
intentionally blank***

CUSTOMER INFORMATION

PRIVACY INFORMATION

BRP wishes to inform you that your coordinates will be used for safety and warranty related purposes. Furthermore, BRP and its affiliates may use its customer list to distribute marketing and promotional information about BRP and related products.

To exercise your right to consult or correct your data, or to be removed from the addressee-list for direct marketing, please contact BRP.

By E-mail: privacyofficer@brp.com

By mail: BRP
Senior Legal Counsel-Privacy Officer
726 St-Joseph
Valcourt Quebec
Canada,
J0E 2L0

CONTACT US

www.brp.com

North America

565 de la Montagne Street
Valcourt (Québec) J0E 2L0
Canada

Sturtevant, Wisconsin, U.S.A.
10101 Science Drive
Sturtevant, Wisconsin
53177
U.S.A.

Sa De Cv, Av. Ferrocarril 202
Parque Ind. Querétaro, Lote2-B
76220
Santa Rosa Jáuregui, Qro., Mexico

Europe

Skaldenstraat 125
B-9042 Gent
Belgium

Itterpark 11
D-40724 Hilden
Germany

ARTEPARC Bâtiment B
Route de la côte d'Azur, Le Canet
13590 Meyreuil
France

Ingvald Ystgaardsvei 15
N-7484 Trondeim
Norway

Isoaavantie 7
PL 8040
96101 Rovaniemi

Formvägen 16
S-906 21 Umeå
Sweden

Avenue d'Ouchy 4-6
1006 Lausanne
Switzerland

Oceania

6 Lord Street
Lakes Business Park
Botany, NSW 2019
Australia

South America

Rua James Clerck Maxwell, 230
TechnoPark Campinas SP 13069-380
Brazil

Asia

15/F Parale Mitsui Building,8
Higashida-Cho, Kawasaki-ku
Kawasaki 210-0005
Japan

Room Dubai, level 12, Platinum Tower
233 Tai Cang Road
Xintiandi, Lu Wan District
Shanghai 200020
PR China

CHANGE OF ADDRESS/OWNERSHIP

If your address has changed or if you are the new owner of the trailer, be sure to notify BRP by either:

- Notifying an authorized Sea-Doo dealer.
- **North America Only:** calling at 1 888 272-9222.
- Mailing one of the change of address cards on the following pages at one of the BRP addresses indicated in the *CONTACT US* section of this guide.

In case of change of ownership, please join a proof that the former owner agreed to the transfer.

Notifying BRP, even after the expiration of the limited warranty, is very important as it enables BRP to reach the trailer owner if necessary, like when safety recalls are initiated. It is the owner's responsibility to notify BRP.

STOLEN UNITS: In the event that your trailer is stolen, you should notify your area's distributor warranty department of such. We will ask you to provide your name, address, phone number, Hull Identification Number and date it was stolen.

***This page is
intentionally blank***

***This page is
intentionally blank***



219 002 031

OPERATOR'S GUIDE, SEA-DOO MOVE TRAILER / ENGLISH
GUIDE DU CONDUCTEUR, SEA-DOO MOVE TRAILER / ANGLAIS

FAIT AU / MADE IN CANADA

U/M:P:C

©™ AND THE BRP LOGO ARE TRADEMARKS OF BOMBARDIER RECREATIONAL PRODUCTS INC. OR ITS AFFILIATES.
©2018 BOMBARDIER RECREATIONAL PRODUCTS INC. ALL RIGHTS RESERVED. PRINTED IN CANADA.