

# SEA-DOO®



# 2014 USER'S GUIDE



## Sea-Doo MOVE Trailer

**⚠ WARNING**

Read this User's Guide.  
It contains important safety information.  
Keep this User's Guide for reference.

2 1 9 0 0 1 3 6 3

Original Instructions

 **WARNING**

Disregarding any of the safety precautions and instructions contained in this guide and on-product labels could cause injury including the possibility of death!

In Canada, products are distributed by Bombardier Recreational Products Inc. (BRP).

In USA, products are distributed by BRP US Inc.

GTX<sup>†</sup> is a registered trademark of Castrol Ltd. used under license.

This is a non-exhaustive list of trademarks that are the property of Bombardier Recreational Products Inc. or its affiliates:

Sea-Doo MOVE™

GTR™

RXT™

aS™

iCatch™

Sea-Doo®

GTI™

iS™

WAKE™

GTS™

RXP™

Spark™

---

# INTRODUCTION

Congratulations on your purchase of your new BRP Sea-Doo MOVE™ trailer. It is backed by the BRP warranty and a network of authorized Sea-Doo personal watercraft (PWC) dealers ready to provide the parts or service you may require.

## Know Before You Go

Read this guide and follow all instructions before installing or using this product.

Read all on-product safety labels carefully and follow the operating procedures described.

Failure to follow the warnings contained in this User's Guide can result in **SERIOUS INJURY** or **DEATH**.

## About this User's Guide

The following guide will help you become better acquainted with your new trailer and its safe operation.

Keep this User's Guide in the tow vehicle so you can refer to it.

If you want to view and/or print an extra copy of this User's Guide, simply visit the following website:

[www.operatorsguide.brp.com](http://www.operatorsguide.brp.com)

It is understood that this User's Guide may be translated into another language. In the event of any discrepancy, the English version shall prevail.

The information and components/system descriptions contained in this document are correct at the time of publication. Bombardier Recreational Products Inc., however, maintains a policy of continuous improvement of its products without imposing upon itself any obligation to install them on products previously manufactured. Due to late changes, some differences between the manufactured product and the descriptions and/or specifications in this guide may occur. BRP reserves the right at any time to dis-

continue or change specifications, designs, features or equipment without incurring any obligation upon itself.

The illustrations in this document show the typical construction of the different assemblies and may not reproduce the full detail or exact shape of the parts. However, they represent parts that have the same or similar function.

## Safety Messages

The types of safety messages, what they look like and how they are used in this guide are explained as follows:

### **WARNING**

Indicates a potential hazard which, if not avoided, could result in serious injury or death.

 **CAUTION** Indicates a hazard situation which, if not avoided, could result in minor or moderate injury.

**NOTICE** Indicates an instruction which, if not followed, could severely damage trailer components or other property.

***This page is  
intentionally blank***

---

# TABLE OF CONTENTS

<b>INTRODUCTION</b> .....	<b>1</b>
Know Before You Go .....	1
About this User's Guide .....	1
Safety Messages.....	1

## ***SAFETY INFORMATION***

<b>SPECIAL SAFETY MESSAGES</b> .....	<b>6</b>
Important Warnings.....	6
Important Information .....	6
<b>LOCATION OF THE IMPORTANT LABELS</b> .....	<b>7</b>
Safety Labels .....	7
Technical Information Label .....	9

## ***OPERATING INSTRUCTIONS***

<b>TRAILER SET-UP</b> .....	<b>14</b>
MOVE I and MOVE II with iCatch .....	14
MOVE I and II with Winch .....	21
Spark™ MOVE II .....	22
<b>BEFORE GETTING UNDERWAY</b> .....	<b>23</b>
Attaching the Trailer to the Tow Vehicle .....	23
Pre-Use Inspection.....	25
<b>TOWING THE TRAILER</b> .....	<b>26</b>
<b>LAUNCHING THE WATERCRAFT</b> .....	<b>27</b>
Launching the Watercraft (Trailers with iCatch).....	27
Launching the Watercraft (Trailers with Winch) .....	28
<b>LOADING THE WATERCRAFT</b> .....	<b>29</b>
Loading the Watercraft (Trailers with iCatch) .....	29
Loading the Watercraft (Trailers with Winch) .....	31

## ***TECHNICAL INFORMATION***

<b>TRAILER IDENTIFICATION NUMBER</b> .....	<b>34</b>
<b>SPECIFICATIONS</b> .....	<b>35</b>
<b>REPORTING SAFETY DEFECTS</b> .....	<b>38</b>

## ***MAINTENANCE***

<b>MAINTENANCE SCHEDULE</b> .....	<b>40</b>
At Storage .....	40
At Preseason .....	40
<b>MAINTENANCE PROCEDURES</b> .....	<b>41</b>

**MAINTENANCE PROCEDURES (cont'd)**

Safety Cable ..... 41

Coupler..... 41

Tires ..... 41

Wheels ..... 41

Wheel Bearings and Seals..... 42

Lights..... 42

Winch ..... 43

Jack ..... 43

Wooden Bunks (Sea-Doo MOVE I and II Trailers with Winch) ..... 43

Rollers (Trailers with iCatch) ..... 43

**TRAILER CARE ..... 44**

Salt Water Use ..... 44

Trailer Cleaning ..... 44

**WARRANTY**

**BRP LIMITED WARRANTY USA AND CANADA: 2014 SEA-DOO MOVE™ PWC TRAILER..... 46**

**CUSTOMER INFORMATION**

**PRIVACY INFORMATION ..... 52**

**CHANGE OF ADDRESS/OWNERSHIP..... 53**

# ***SAFETY INFORMATION***

# SPECIAL SAFETY MESSAGES

## Important Warnings

Always perform the *PRE-USE INSPECTION* for safe driving.

Always follow guidelines in *TOWING THE TRAILER*.

Maintain your trailer as per the *MAINTENANCE SCHEDULE*.

## Important Information

### Trailer

This BRP Sea-Doo MOVE™ trailer has been specially designed to carry a personal watercraft (PWC).

### WARNING

iCatch™ mechanism must be specifically adjusted to the personal watercraft (PWC) model and used exclusively with the iCatch bow cup. An Incorrect adjustment may cause the iCatch mechanism to not adequately secure the personal watercraft (PWC) to the trailer.

### Hitch

### WARNING

The use of a hitch with an insufficient load rating can result in hitch breakdown.

Be sure the hitch ball size matches the coupler size.

Inspect the hitch for wear, corrosion and cracks before coupling. Replace the required components if any of the above conditions is observed.

### WARNING

Do not tow whenever a component is defective.

**NOTICE** The coupling socket should not be allowed to rest on the ground where dirt and sand can enter the socket. This will lead to excessive wear or cause the locking mechanism to jam.

Ensure hitch is tight before coupling the trailer to the vehicle.

### WARNING

An improperly coupled trailer can result in a loss of control or serious road hazard. Never use the trailer pre-use inspection is completed.

### Tow Vehicle

Some vehicles are not intended to tow a trailer. Make sure your vehicle is designed to tow a trailer and its towing capacity is sufficient.

### WARNING

Never tow this trailer with a vehicle not intended for trailer towing or with an insufficient towing capacity.

### Accessories and Modifications

We recommend to use replacement parts and accessories from BRP. They've been especially designed for your trailer and manufactured to meet BRP's demanding standards.

Do not make unauthorized modifications, or use accessories that are not approved by BRP. Since these changes have not been tested by BRP, they may increase the risk of accidents or injuries, and they can make the trailer illegal for use.



# LOCATION OF THE IMPORTANT LABELS

The following labels are on your trailer. If missing or damaged, they can be replaced free of charge. See an authorized Sea-Doo dealer.

Please read the following labels carefully before using your trailer.

## Safety Labels

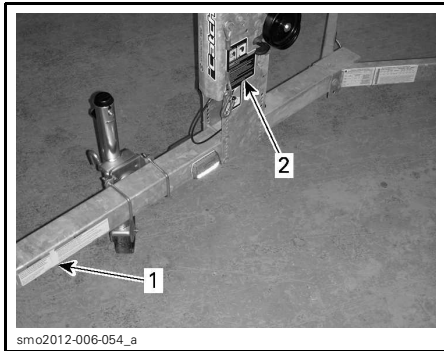

TYPICAL - MOVE I TRAILER WITH iCATCH

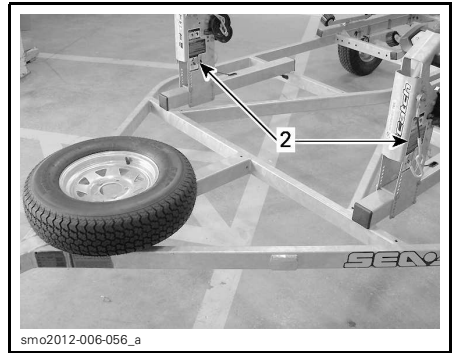

MOVE II TRAILER WITH iCATCH



MOVE I AND II TRAILERS WITH WINCH

### ⚠ WARNING

**Serious injury or death can result if this trailer is towed before familiarizing yourself with the manufacturer's operation instructions listed below.**

Do not exceed the tow vehicle's "tow rating" or exceed the GVWR or GCWR.

219903238

LABEL 1 (ALL TRAILERS)

### ⚠ WARNING

**Before towing this trailer check that:**

- Coupler hitch and trailer ball are the same size. Coupler is latched. Safety chains are crisscrossed under tongue and attached to towing vehicle.
- All trailer lighting is working correctly. Load is secured to trailer (front and rear). Tongue jack (if trailer is equipped) is retracted.
- Wheel lug bolts are properly tightened. Tires are inflated to pressure indicated on tire.
- Load is within trailer capacity and distributed properly to maintain proper tongue weight.

You are required to comply with local and state requirements regarding brakes, licensing and any additional equipment that may be necessary. Contact your state motor vehicle department for more information.

219 903 238

**TO LOCK:**

1 FULLY TURN CCW      2 INSERT TO LOCK

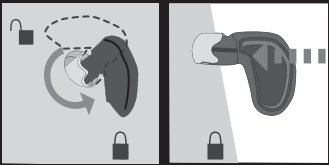

**TO UNLOCK: PULL AND TURN CW**

**⚠ WARNING**

ALWAYS MAKE SURE THAT THE:

- iCatch system is properly adjusted to fit the PWC.
- iCatch lever is in the UNLOCK position to load or unload the PWC.

BEFORE TOWING WHEN A PWC IS LATCHED INTO THE iCatch:

- Make sure the PWC is securely latched in the front.
- Secure iCatch hook by turning lever to the LOCK position.
- Attach the loose end of the safety cable onto the iCatch bow cup.
- Fasten the stern of the watercraft with 2 ratchet type tie down straps, one on each side.

Never stand on the walk board while PWC is loading on the trailer.  
Walk board is designed to support a person of 160 kg (350 lb) MAX.  
Refer to your user's guide for more details.

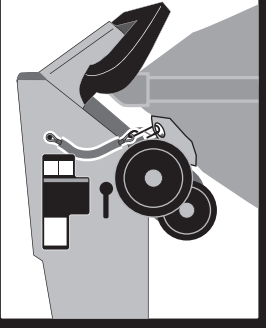

PATENT PENDING 262000192

262000192

**LABEL 2 - TRAILERS WITH iCATCH**



**⚠ WARNING**

Spinning handle could cause serious injury. Hold handle firmly when ratchet is unlocked. Not for moving people or loads over people.

204457B



smo2012-006-008

**LABEL 3 - MOVE I AND II TRAILERS WITH WINCH**

# Technical Information Label

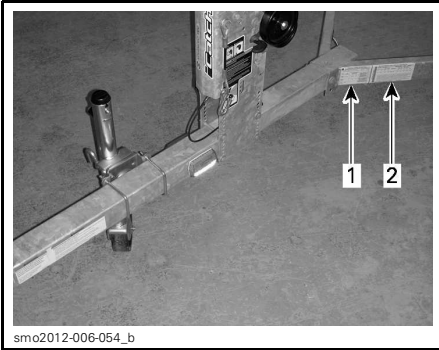

smo2012-006-054\_b

TYPICAL - MOVE I

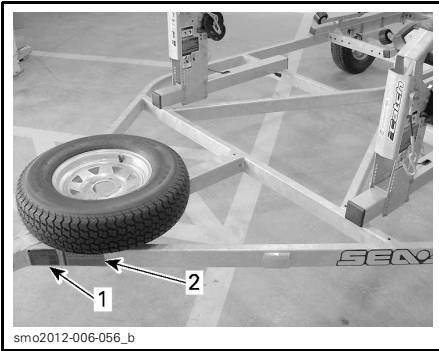

smo2012-006-056\_b

TYPICAL - MOVE II

TIRE AND LOADING INFORMATION RENSEIGNEMENTS SUR LES PNEUS ET LE CHARGEMENT			
The weight of cargo should never exceed Le poids du chargement ne doit jamais dépasser		522 KG or 1150 LB 522 KG ou 1150 LB	
TIRE PNEU	SIZE DIMENSIONS	COLD TIRE PRESSURE PRESSION DES PNEUS A FROID	
FRONT AVANT	4.80 X 12B	413 kPA	60 PSI
REAR ARRIÈRE		0 kPA	PSI
SPARE DE SECOURS	NONE		
SEE OWNER'S MANUAL FOR ADDITIONAL INFORMATION VOIR LE MANUEL DE L'USAGER POUR PLUS DE RENSEIGNEMENTS			

smo2012-006-004\_a

LABEL 1 - MOVE I

TIRE AND LOADING INFORMATION RENSEIGNEMENTS SUR LES PNEUS ET LE CHARGEMENT			
The weight of cargo should never exceed Le poids du chargement ne doit jamais dépasser		567 KG or 1250 LB 567 KG ou 1250 LB	
TIRE PNEU	SIZE DIMENSIONS	COLD TIRE PRESSURE PRESSION DES PNEUS A FROID	
FRONT AVANT	4.80 X 12B	413 kPA	60 PSI
REAR ARRIÈRE		0 kPA	PSI
SPARE DE SECOURS	NONE		
SEE OWNER'S MANUAL FOR ADDITIONAL INFORMATION VOIR LE MANUEL DE L'USAGER POUR PLUS DE RENSEIGNEMENTS			

smo2014-004-001

LABEL 1 - MOVE I EXTENDED 1250

TIRE AND LOADING INFORMATION RENSEIGNEMENTS SUR LES PNEUS ET LE CHARGEMENT			
The weight of cargo should never exceed Le poids du chargement ne doit jamais dépasser		680 KG or 1500 LB 680 KG ou 1500 LB	
TIRE PNEU	SIZE DIMENSIONS	COLD TIRE PRESSURE PRESSION DES PNEUS A FROID	
FRONT AVANT	5.30 X 12C	551 kPA	80 PSI
REAR ARRIÈRE		0 kPA	PSI
SPARE DE SECOURS	NONE		
SEE OWNER'S MANUAL FOR ADDITIONAL INFORMATION VOIR LE MANUEL DE L'USAGER POUR PLUS DE RENSEIGNEMENTS			

smo2013-005-100

LABEL 1 - MOVE I EXTENDED 1500

TIRE AND LOADING INFORMATION RENSEIGNEMENTS SUR LES PNEUS ET LE CHARGEMENT			
The weight of cargo should never exceed Le poids du chargement ne doit jamais dépasser		553 KG or 1220 LB 553 KG ou 1220 LB	
TIRE PNEU	SIZE DIMENSIONS	COLD TIRE PRESSURE PRESSION DES PNEUS A FROID	
FRONT AVANT	4.80 X 12B	413 kPA	60 PSI
REAR ARRIÈRE		0 kPA	PSI
SPARE DE SECOURS	NONE		
SEE OWNER'S MANUAL FOR ADDITIONAL INFORMATION VOIR LE MANUEL DE L'USAGER POUR PLUS DE RENSEIGNEMENTS			

smo2014-004-002

LABEL 1 - SPARK™ MOVE II

**LOCATION OF THE IMPORTANT LABELS**

TIRE AND LOADING INFORMATION RENSEIGNEMENTS SUR LES PNEUS ET LE CHARGEMENT			
The weight of cargo should never exceed Le poids du chargement ne doit jamais dépasser		1111 KG or 2450 LB 1111 KG ou 2450 LB	
TIRE PNEU	SIZE DIMENSIONS	COLD TIRE PRESSURE PRESSION DES PNEUS A FROID	
FRONT AVANT	ST185/80D13C	345 kPa	50 PSI
REAR ARRIÈRE		0 kPa	PSI
SPARE DE SECOURS	NONE		
		SEE OWNER'S MANUAL FOR ADDITIONAL INFORMATION VOIR LE MANUEL DE L'USAGER POUR PLUS DE RENSEIGNEMENTS	

smo2012-006-005\_a

**LABEL 1 - MOVE II**

MFD BY/FABRIQUE PAR: KARAVAN TRAILERS INC.											
DATE: June 2011				MADE IN USA				JOB# 284645			
PNBV / GVWR		PNBE / GAWR		TIRE/PNEU		COLD INFL. PRESSURE		MAX. LOAD CARRYING CAP			
KG	LB	KG	LB			KPA	PSI	KG	LB	RIM	
671	1479	671	1479	4.80 X 12B		413	60	522	1150	12x4	
0											
THIS VEHICLE CONFORMS TO ALL APPLICABLE U.S. FEDERAL MOTOR VEHICLE SAFETY STANDARDS (FMVSS) IN EFFECT ON THE DATE OF MANUFACTURE SHOWN ABOVE. THIS VEHICLE CONFORMS TO ALL APPLICABLE STANDARDS PRESCRIBED UNDER THE CANADIAN MOTOR VEHICLE SAFETY REGULATIONS IN EFFECT ON THE DATE OF MANUFACTURE SHOWN ABOVE. / CE VEHICULE EST CONFORME A TOUTES LES NORMES QUI LUI SONT APPLICABLES EN VERTU DU REGLEMENT SUR LA SECURITE DES VEHICULES AUTOMOBILES DU CANADA EN VIGUEUR A LA DATE DE SA FABRICATION.											
TYPE: /TRA/REM WATERCRAFT TRAILER								WCE-1250-46			

smo2012-006-002

**LABEL 2 - MOVE I**

MFD BY/FABRIQUE PAR: KARAVAN TRAILERS INC.											
DATE: January 2013				MADE IN USA				JOB# 350257			
PNBV / GVWR		PNBE / GAWR		TIRE/PNEU		COLD INFL. PRESSURE		MAX. LOAD CARRYING CAP			
KG	LB	KG	LB			KPA	PSI	KG	LB	RIM	
680	1500	680	1500	4.80 X 12B		413	60	567	1250	12x4	
0											
THIS VEHICLE CONFORMS TO ALL APPLICABLE U.S. FEDERAL MOTOR VEHICLE SAFETY STANDARDS (FMVSS) IN EFFECT ON THE DATE OF MANUFACTURE SHOWN ABOVE. THIS VEHICLE CONFORMS TO ALL APPLICABLE STANDARDS PRESCRIBED UNDER THE CANADIAN MOTOR VEHICLE SAFETY REGULATIONS IN EFFECT ON THE DATE OF MANUFACTURE SHOWN ABOVE. / CE VEHICULE EST CONFORME A TOUTES LES NORMES QUI LUI SONT APPLICABLES EN VERTU DU REGLEMENT SUR LA SECURITE DES VEHICULES AUTOMOBILES DU CANADA EN VIGUEUR A LA DATE DE SA FABRICATION.											
TYPE: /TRA/REM WATERCRAFT TRAILER								MOVE I LONG			

smo2014-004-004

**LABEL 2 - MOVE I EXTENDED 1250**

MFD BY/FABRIQUE PAR: KARAVAN TRAILERS INC.

DATE: April 2012		MADE IN USA		JOB# 319583	
ALL AXLES		COLD INFL.		MAX. LOAD	
PNBV / GVWR		PNBE / GAWR		TIRE/PNEU	
KG	LB	KG	LB	KPA	PSI
805	1775	805	1775	551	80
				PRESSURE CARRYING CAI	
				KG LB RIM	
				680 1500 12x4	
0					

THIS VEHICLE CONFORMS TO ALL APPLICABLE U.S. FEDERAL MOTOR VEHICLE SAFETY STANDARDS (FMVSS) IN EFFECT ON THE DATE OF MANUFACTURE SHOWN ABOVE. THIS VEHICLE CONFORMS TO ALL APPLICABLE STANDARDS PRESCRIBED UNDER THE CANADIAN MOTOR VEHICLE SAFETY REGULATIONS IN EFFECT ON THE DATE OF MANUFACTURE SHOWN ABOVE. / CE VEHICULE EST CONFORME A TOUTES LES NORMES QUI LUI SONT APPLICABLES EN VERTU DU REGLEMENT SUR LA SECURITE DES VEHICULES AUTOMOBILES DU CANADA EN VIGUEUR A LA DATE DE SA FABRICATION.

TYPE: /TRA/REM WATERCRAFT TRAILER WCE-1500-46

sma2013-005-101

LABEL 2 - MOVE I EXTENDED 1500

MFD BY/FABRIQUE PAR: KARAVAN TRAILERS INC.

DATE: June 2011		MADE IN USA		JOB# 284649	
ALL AXLES		COLD INFL.		MAX. LOAD	
PNBV / GVWR		PNBE / GAWR		TIRE/PNEU	
KG	LB	KG	LB	KPA	PSI
1331	2935	1331	2935	345	50
				PRESSURE CARRYING CAI	
				KG LB RIM	
				1111 2450 +13x4.5	
0					

THIS VEHICLE CONFORMS TO ALL APPLICABLE U.S. FEDERAL MOTOR VEHICLE SAFETY STANDARDS (FMVSS) IN EFFECT ON THE DATE OF MANUFACTURE SHOWN ABOVE. THIS VEHICLE CONFORMS TO ALL APPLICABLE STANDARDS PRESCRIBED UNDER THE CANADIAN MOTOR VEHICLE SAFETY REGULATIONS IN EFFECT ON THE DATE OF MANUFACTURE SHOWN ABOVE. / CE VEHICULE EST CONFORME A TOUTES LES NORMES QUI LUI SONT APPLICABLES EN VERTU DU REGLEMENT SUR LA SECURITE DES VEHICULES AUTOMOBILES DU CANADA EN VIGUEUR A LA DATE DE SA FABRICATION.

TYPE: /TRA/REM WATERCRAFT TRAILER WC-2450-84

sma2012-006-003

LABEL 2 - MOVE II

MFD BY/FABRIQUE PAR: KARAVAN TRAILERS INC.

DATE: April 2013		MADE IN USA		JOB# 360212	
ALL AXLES		COLD INFL.		MAX. LOAD	
PNBV / GVWR		PNBE / GAWR		TIRE/PNEU	
KG	LB	KG	LB	KPA	PSI
708	1560	708	1560	413	60
				PRESSURE CARRYING CAP.	
				KG LB RIM	
				553 1220 12x4	
0					

THIS VEHICLE CONFORMS TO ALL APPLICABLE U.S. FEDERAL MOTOR VEHICLE SAFETY STANDARDS (FMVSS) IN EFFECT ON THE DATE OF MANUFACTURE SHOWN ABOVE. THIS VEHICLE CONFORMS TO ALL APPLICABLE STANDARDS PRESCRIBED UNDER THE CANADIAN MOTOR VEHICLE SAFETY REGULATIONS IN EFFECT ON THE DATE OF MANUFACTURE SHOWN ABOVE. / CE VEHICULE EST CONFORME A TOUTES LES NORMES QUI LUI SONT APPLICABLES EN VERTU DU REGLEMENT SUR LA SECURITE DES VEHICULES AUTOMOBILES DU CANADA EN VIGUEUR A LA DATE DE SA FABRICATION.

TYPE: /TRA/REM WATERCRAFT TRAILER MOVE II SHORT

sma2014-004-003

LABEL 2 - SPARK™ MOVE II

***This page is  
intentionally blank***

# ***OPERATING INSTRUCTIONS***

# TRAILER SET-UP

## MOVE I and MOVE II with iCatch

The iCatch system must be adjusted specifically to the personal watercraft (PWC) hull type.

The iCatch system must be used along with the iCatch bow cup on selected models or available at an authorized Sea-Doo dealer.

### **⚠ WARNING**

**iCatch mechanism must be specifically adjusted to the personal watercraft (PWC) model and used exclusively with the iCatch bow cup. An incorrect adjustment may cause the iCatch mechanism to not adequately secure the personal watercraft (PWC) to the trailer.**

There are four parameters to set on the iCatch system to fit the listed Sea-Doo models:

- iCatch housing angle
- iCatch support height
- Bumper position
- Rollers position.

Also, tongue weight and axle positioning must be adjusted if necessary. Tongue weight is adjusted by changing the iCatch support and/or axle position on the frame.

To properly adjust the iCatch, refer to table below to find the setting type according to your watercraft model.

Proceed with all adjustments according to your setting type.

SETTING TYPE TABLE		
MODEL NAME	MODEL YEAR	SETTING TYPE
GTX <sup>†</sup> , RXT <sup>™</sup> , RXT-X <sup>™</sup> , RXT-X RS and WAKE <sup>™</sup> Pro	2010 - 2014	A
GTX Limited 215	2014	
GTX Limited iS and RXT iS <sup>™</sup>	2009 - 2014	
RXT-X aS <sup>™</sup> , RXT-X RS aS	2011 - 2014	
GTX, GTX WAKE, RXT and RXT-X	2002 through 2009	B
GTI <sup>™</sup> , GTI SE and WAKE 155	2006 through 2010	C
GTS <sup>™</sup> PRO	2011	
RXP <sup>™</sup>	2004 through 2011	D
RXP-X and RXP-X RS	2008 through 2011	
GTI, GTI Limited, GTI SE, GTR <sup>™</sup> , GTS and WAKE	2011 - 2014	E
RXP	2012 - 2014	F

**NOTE:** On Sea-Doo MOVE II trailers with iCatch, when the adjustments are completed, make sure you install the applicable iCatch 1 and iCatch 2 decals on the PWC. The decals should be clearly visible and installed on the glove box cover.





smo2012-007-051

**ICATCH 1 AND ICATCH 2 DECALS****iCatch Housing Angle Setting**

<b>ICATCH HOUSING ANGLE SETTING</b>		
	MOVE I	MOVE II
Setting "A"	2	2
Setting "B"	2	3
Setting "C"	3	3
Setting "D"	1	1
Setting "E"	2	3
Setting "F"	2	2

1. Loosen the iCatch housing upper bolt.
2. Remove the iCatch housing lower bolt.

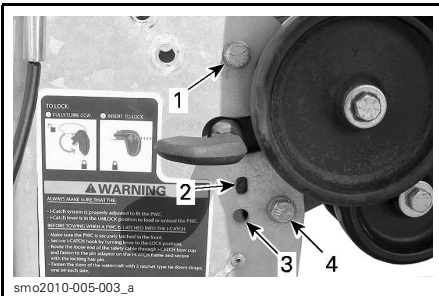

smo2010-005-003\_a

1. Upper bolt
2. Window
3. Lower front hole
4. Lower bolt (in rear hole)

## 3. Set angle:

- 3.1 Bring angle to the appropriate setting. The setting refers to the number visible in the window.
- 3.2 Lock iCatch housing in place by inserting the bolt through the appropriate lower hole.

**NOTE:** The front or rear lower hole will be aligned with the iCatch housing hole depending on the setting.

- 3.3 Tighten nuts according to the following table.

<b>TIGHTENING TORQUE</b>	
iCatch housing nuts	27 N•m ± 3 N•m (20 lbf•ft ± 2 lbf•ft)

**iCatch Support Height Setting**

<b>ICATCH SUPPORT HEIGHT SETTING (LOWER BOLT POSITION)</b>		
	MOVE I	MOVE II
Setting "A"	1	1
Setting "B"	3	3
Setting "C"	2	3
Setting "D"	2	3
Setting "E"	2	2
Setting "F"	1	2

1. Remove iCatch support bolts and install in the appropriate holes.

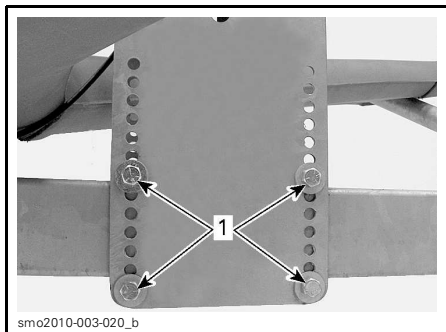

1. iCatch support bolts

**NOTE:** The iCatch support height setting refers to the lower bolt position. Insert upper bolt just above the tongue.

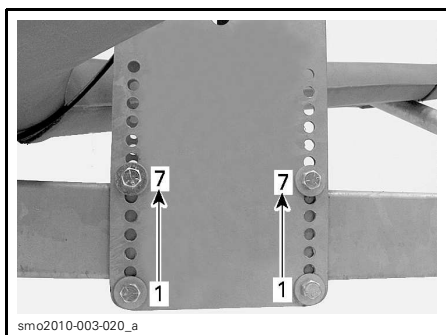

1. Position 1  
7. Position 7

**⚠ WARNING**

There must be precisely 5 unused holes between upper and lower bolts.

2. Progressively tighten nuts in a criss-cross pattern until support is square with the trailer tongue. Do not tighten yet.
3. Adjust tongue weight, refer to *TONGUE WEIGHT* section.
4. Apply final tightening torque.

TIGHTENING TORQUE	
iCatch support nuts	8 N•m ± 1 N•m (71 lbf•in ± 9 lbf•in)

## Bumper Position Setting

iCATCH BUMPER POSITION SETTING			
		MOVE I	MOVE II
Setting "A"	Bumper holes	2	2
	Support holes	3	3
Setting "B"	Bumper holes	1	1
	Support holes	1	1
Setting "C"	Bumper holes	1	1
	Support holes	1	1
Setting "D"	Bumper holes	1	1
	Support holes	3	3
Setting "E"	Bumper holes	2	2
	Support holes	3	3
Setting "F"	Bumper holes	1	1
	Support holes	2	2

The bumper position setting consists of a particular position of both the bumper holes and support holes.

1. Remove bumper retaining bolts.
2. Align appropriate support holes and bumper together.

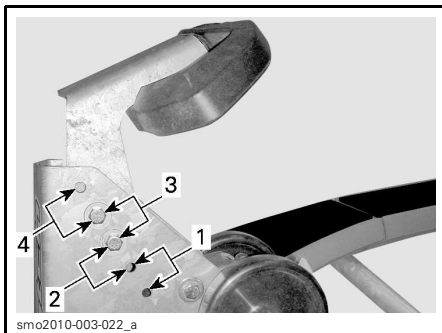

### SUPPORT HOLES

1. Position 1
2. Position 2
3. Position 3
4. Position 4

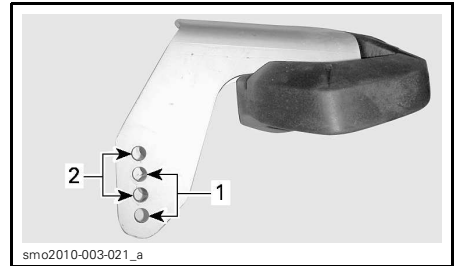

### BUMPER HOLES

1. Position 1
2. Position 2
3. Install bolts loosely into proper positions.
4. **IMPORTANT:** Move bumper upwards then towards front and maintain it in this position.



smo2010-004-500\_a

**MOVE UPWARDS THEN FORWARD**

5. Tighten bumper retaining bolts to specification.

**NOTE:** It is important to maintain bumper fully upwards and forward to eliminate any play in the assembly before tightening.

TIGHTENING TORQUE	
Bumper retaining bolts	27 N•m ± 3 N•m (20 lbf•ft ± 2 lbf•ft)

**Rollers Position Setting**

iCATCH ROLLERS POSITION SETTING			
		MOVE I	MOVE II
Setting "A"	Front	1	1
	Rear	3	3
Setting "B"	Front	1	1
	Rear	3	3
Setting "C"	Front	1	1
	Rear	3	3
Setting "D"	Front	1	1
	Rear	3	3

iCATCH ROLLERS POSITION SETTING			
		MOVE I	MOVE II
Setting "E"	Front	1	1
	Rear	3	3
Setting "F"	Front	1	1
	Rear	3	3

1. Remove 2 rollers retaining bolts.

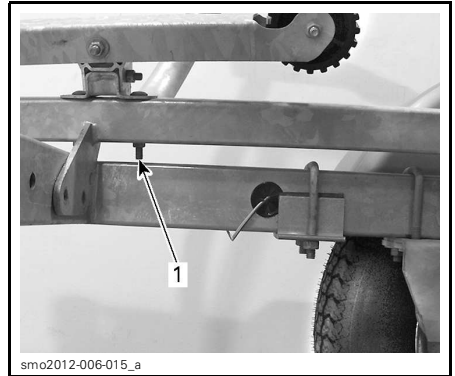

smo2012-006-015\_a

1. Rollers retaining bolt

2. Align appropriate holes and rollers together.

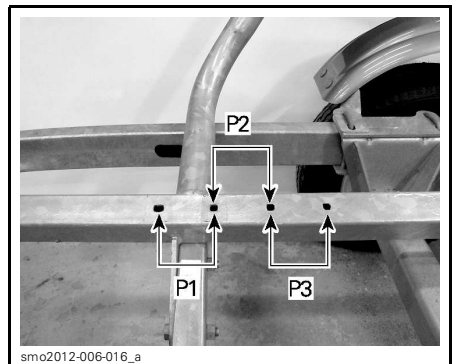

smo2012-006-016\_a

**FORWARD ROLLER ADJUSTMENT HOLES**

- P1 = Position 1
- P2 = Position 2
- P3 = Position 3

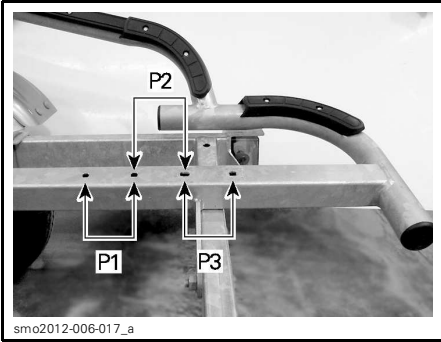

**AFT ROLLER ADJUSTMENT HOLES**

- P1 = Position 1
- P2 = Position 2
- P3 = Position 3

3. Install bolts loosely into proper positions.
4. Tighten bolts according to the following table.

TIGHTENING TORQUE	
Roller retaining bolts	27 N•m ± 3 N•m (20 lbf•ft ± 2 lbf•ft)

**Axle Positioning (MOVE I Only)**

To suit all Sea-Doo watercraft models, the trailer axle on MOVE I must be moved forward from the factory position.

This table lists the applicable distance of the axle bracket in reference with the frame.

AXLE POSITIONING (MOVE I ONLY)	
	MOVE I
Setting "A"	205 mm (8.07 in)
Setting "B"	78 mm (3.07 in)
Setting "C"	78 mm (3.07 in)
Setting "D"	25 mm (.98 in)
Setting "E"	52 mm (2.05 in)
Setting "F"	103 mm (4.06 in)

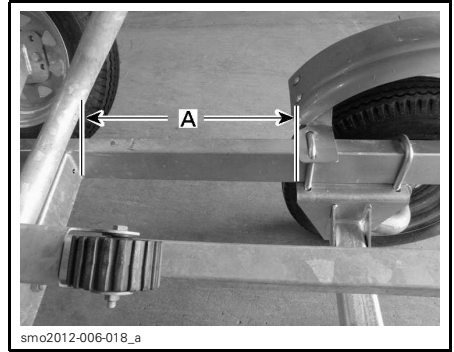

**AXLE POSITIONING**

A. Distance to be measured as per table

To set axle to the required position, proceed as follows:

1. Measure and record distance between the fender U-bolt and adjacent U-bolt.

**NOTE:** This measure will be needed before tightening the U-bolt nuts.

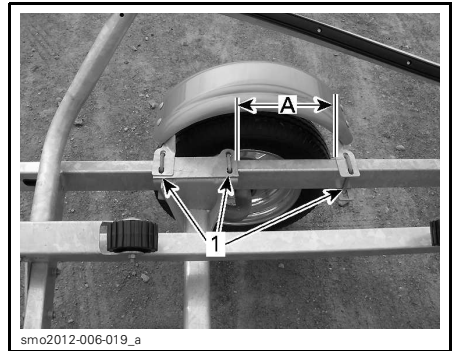

**AXLE ADJUSTMENT**

1. U-bolts
  - A. Fender adjustment distance
2. Loosen 6 U-bolt nuts that fasten the axle and fender to the frame.
3. Move axle to the desired position (as per *AXLE POSITIONING TABLE* information).
4. Adjust the fender adjustment distance according to the measured distance of step 1.

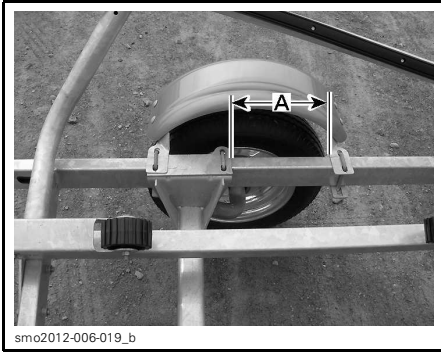

A. Fender adjustment distance

5. Tighten nuts according to the following table.

TIGHTENING TORQUE	
U-bolt retaining nuts	11.5 N•m ± 1.5 N•m (102 lbf•in ± 13 lbf•in)

### Tongue Weight

Move iCatch support towards front or rear of trailer in order to adjust tongue weight.

The tongue weight should be from 3 to 10% of the total trailer and PWC weight with tongue parallel to the ground.

A measurement is provided as an indication, however, the 3 to 10% rule prevails.

See following illustration and table for measurement instructions.

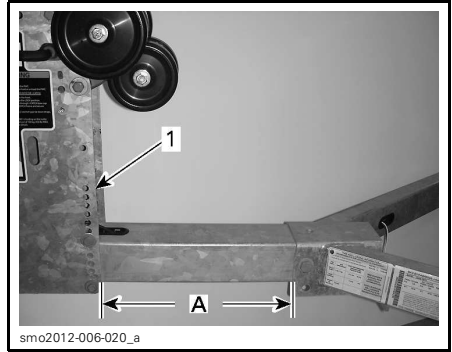

### MOVE I TONGUE MEASUREMENT

1. iCatch support

A. Distance to be measured as per table

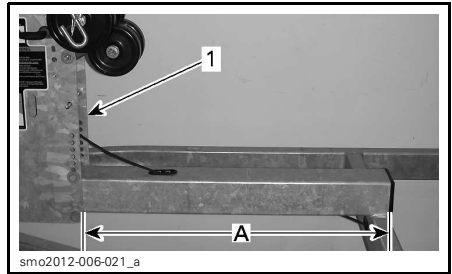

### MOVE II TONGUE MEASUREMENT

1. iCatch support

A. Distance to be measured as per table

TONGUE DISTANCE SETTING		
	MOVE I	MOVE II
Setting "A"	330 mm (13 in)	620 mm (24.4 in)
Setting "B"	340 mm (13.4 in)	480 mm (18.9 in)
Setting "C"	305 mm (12 in)	305 mm (12 in)
Setting "D"	255 mm (10 in)	200 mm (7.9 in)
Setting "E"	330 mm (13 in)	440 mm (17.3 in)
Setting "F"	315 mm (12.4 in)	430 mm (16.9 in)

To adjust, loosen the iCatch support bolts, move support to the desired position, then tighten nuts as follows:

1. Progressively tighten nuts in a crisscross pattern until support is square with the trailer tongue.
2. Apply final tightening torque.

TIGHTENING TORQUE	
iCatch support bolts	8 N•m ± 1 N•m (71 lbf•in ± 9 lbf•in)

## MOVE I and II with Winch

Set tongue weight, bow stopper roller, and bunks as follows.

**NOTE:** For these trailers, the axle must be kept in factory position all the time.

### Tongue Weight

Move winch support towards front or rear of trailer in order adjust tongue weight.

The tongue weight should be from 3 to 10% of the total trailer and PWC weight with tongue parallel to the ground.

To adjust, loosen the 4 nuts underneath the winch support U-bolts, move winch support to the desired position, then tighten nuts as per the following table.

TIGHTENING TORQUE	
Winch support U-bolt nuts	27 N•m ± 3 N•m (20 lbf•ft ± 2 lbf•ft)

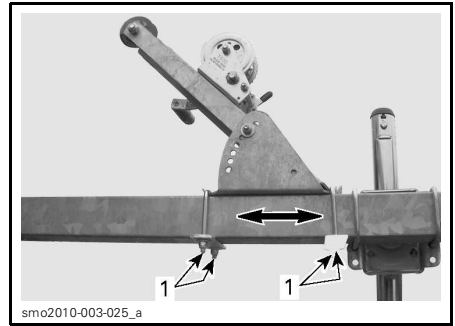

1. Winch support U-bolts nuts

## Bow Stopper Roller

Set bow roller stopper so that it leans on the PWC bow between rubber bumper and bow eyelet (or bow cup on selected models).

To adjust:

1. Loosen the 2 nuts underneath the front winch support U-bolt.
2. Remove the winch arm adjustment bolt.
3. Set the bow roller stopper to the desired height, then lock it in position by inserting the bolt through the aligned winch support and winch arm holes.

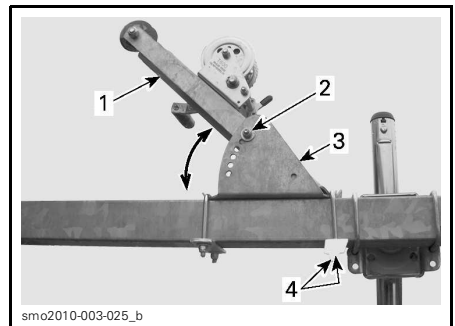

1. Winch arm  
2. Winch arm adjustment bolt  
3. Winch support  
4. Front U-bolt nuts

4. Tighten the fasteners according to the following table.

TIGHTENING TORQUE	
U-bolts nuts	27 N•m ± 3 N•m (20 lbf•ft ± 2 lbf•ft)
Winch arm adjustment bolt	27 N•m ± 3 N•m (20 lbf•ft ± 2 lbf•ft)

### Bunks

The wooden bunks are preset to suit all Sea-Doo personal watercraft (PWC) hull designs, however, a universal rule applies: bunks must lean square against a plain area of the hull.

Make sure the bunks are well positioned.

To adjust:

1. Loosen the 2 nuts underneath the bunk when the PWC is not on the trailer.
2. Put the PWC on the trailer so the bunks are square with hull as shown on illustration.

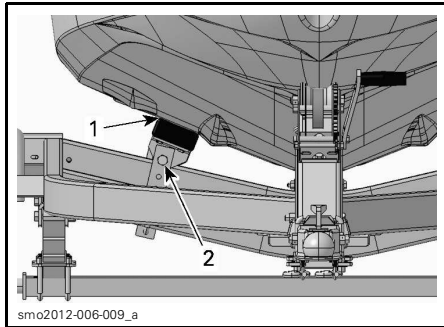

#### MOVE I TRAILER

1. Bunk square with hull
2. Nut

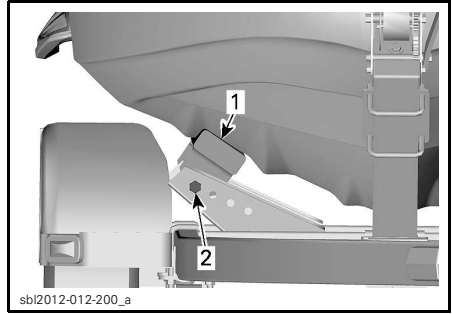

#### MOVE II TRAILER

1. Bunk square with hull
2. Nut

3. Tighten 2 nuts according to the following table.

TIGHTENING TORQUE	
Bunk retaining nuts	21 N•m ± 3 N•m (15 lbf•ft ± 2 lbf•ft)

### Spark™ MOVE II

This trailer is specifically made to transport the Spark™ PWC. No adjustment is required.

**NOTICE** Do not use this trailer to transport any other PWC. Use this trailer only to transport the Spark™ PWC.



# BEFORE GETTING UNDERWAY

## Attaching the Trailer to the Tow Vehicle

1. Make sure that the coupler and hitch ball are the same size (2 in).
2. Have someone guiding you and back the tow vehicle as close as possible to the trailer. This is easier and safer than pulling the trailer to the vehicle.
3. Be sure the coupler-locking mechanism is released.
4. Raise the front end of the trailer. Position the coupler directly over the hitch ball and lower until it is all the way down.

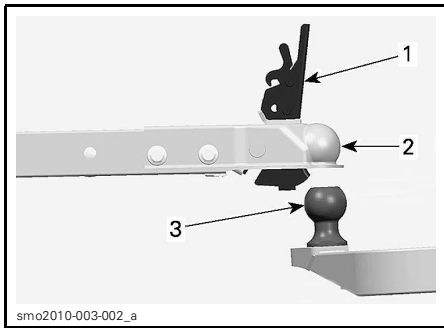

### TYPICAL

1. Coupler-locking mechanism (released)
2. Coupler
3. Hitch ball

5. Check under the coupling to be certain that the ball clamp is below the ball and not riding on top of the ball.

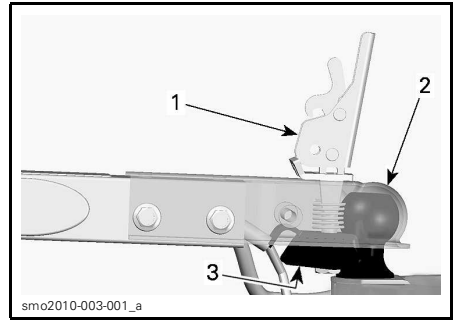

### TYPICAL

1. Coupler-locking mechanism (released)
2. Hitch ball in coupler
3. Ball clamp

6. Lock the coupler to the hitch ball. Be sure the coupler is in the locked position and the locking pin is placed through the coupler-locking mechanism. Lift up on the trailer tongue. If it comes loose from the ball, unlock and start procedure again.

## **⚠️ WARNING**

If the coupler cannot be secured to hitch ball, do not tow the trailer. Refer to an authorized Sea-Doo dealer to inspect the trailer as soon as possible.

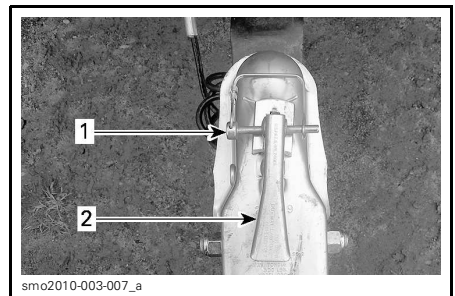

1. Locking pin
2. Coupler-locking mechanism in locked position

**NOTE:** At this point the tow vehicle and the trailer should be level.

7. Attach the tongue safety cables or chains. Attach the left cable or chain to the bracket on the right side of hitch and the right cable or chain to the left bracket.

**NOTICE** To avoid damaging wiring harness, ensure the harness is not passed between the tongue safety cables or chains.

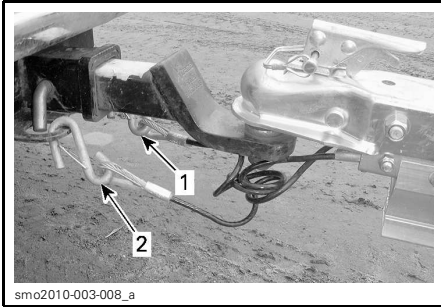

1. LH tongue safety cable attached to the RH side of hitch
  2. RH tongue safety cable attached to the LH side of hitch
8. Connect lights connector.

## Pre-Use Inspection

### WARNING

Perform a pre-use inspection before each use to detect potential problems during operation. The pre-use inspection can help you monitor wear and deterioration before they become a problem. Correct any problems that you discover to reduce the risk of a breakdown or crash. See an authorized Sea-Doo dealer as necessary.

OPERATION	✓
Make sure the hitch ball size matches the coupler size (5 cm (2 in)).	
Check that the personal watercraft (PWC) is ready to be towed according to the PWC manufacturer's recommendations.	
Check that the jack is retracted.	
Check tires condition and if they are properly inflated. Refer to <i>MAINTENANCE PROCEDURES</i> for details.	
Check tightness of wheel lug nuts.	
Check if load is within maximum load carrying capacity.	
Check if coupler is latched and locked.	
Check if tongue safety cables or chains are crisscrossed under tongue and attached to hitch.	
Check lights operation.	
Clean all reflectors and lights lenses.	
Check if personal watercraft (PWC) is properly secured to the trailer at rear.	
Check that the iCatch system or winch is locked.	
Make sure the personal watercraft (PWC) is properly secured at front using the safety cable and at back using tie-downs.	

---

## TOWING THE TRAILER

Follow the tow vehicle's manufacturer instructions regarding trailer towing.

**SEVERE INJURY OR DEATH** can result if you do not follow these instructions:

When towing the trailer, pay particular attention to the following:

- Use a longer following distance from the vehicle in front of you.
- When towing a trailer, more time and distance are needed when passing or stopping.
- Reduce your speed and slow down more than usual before turning and avoid sharp turns.
- When cornering, achieve the turn on a larger radius. It takes more space to turn with a trailer.
- Always move slowly when backing up. Ask someone to guide you when possible. Practice in an open area at the first opportunity.
- If trailer starts to sway, do not hit the brakes or compensate using the steering wheel. Reduce speed and maintain a steady course.
- When going downhill, reduce speed before starting the descent. Do not brake continuously. Apply and release brakes alternately to prevent brakes from overheating.

Loss of control of the trailer or trailer/vehicle combination can result in serious injury or death. The most common causes of loss of control of the trailer are:

- Driving too fast for the conditions.
- Overloading the trailer or loading the trailer incorrectly.
- Trailer improperly coupled to the hitch.
- Inadequate towing hitch.
- Not maintaining proper tire pressure.
- Not keeping wheel lug nuts tight.

# LAUNCHING THE WATERCRAFT

## Launching the Watercraft (Trailers with iCatch)

1. Prepare the personal watercraft (PWC) for launching according to the PWC manufacturer's recommendations.
2. Remove tie-downs from stern and trailer eyelets.
3. Disconnect lights connector.
4. Make sure the way is clear behind the trailer (in and out of water).

**⚠ CAUTION** The watercraft can easily travel 10 m (33 ft) on the water once launched from the trailer.

5. Have someone guiding you and back the vehicle until water level is within the water level decal upper and lower edges.



**WATER LEVEL DECAL**

**NOTE:** On very gentle slopes, water level may go over the decal zone, however, the PWC must not float above the rollers.

6. Hold the clip and remove safety cable hook from bow cup.

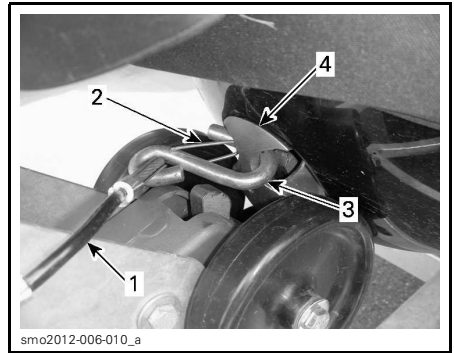

### SAFETY CABLE

1. Safety cable
2. Clip
3. Hook
4. Bow cup

7. Unlock the iCatch mechanism by pulling lever out and turning clockwise.



- Step 1: Pull lever out
- Step 2: Turn clockwise

**NOTE:** Always make sure that the iCatch system is unlocked before attempting to unload the PWC.

8. Take place on the watercraft.

**⚠ WARNING**  
Be careful if walking on the trailer, as surfaces may be very slippery.

9. Put your personal flotation device (PFD) on and attach the safety lanyard to it.

10. Get watercraft ready for engine starting but do not start engine yet.
11. Pull the iCatch release handle up. Handle will stay up indicating that the iCatch is ready for further loading.

**NOTE:** If you are launching from a dual trailer, make sure you release the applicable handle by using the indication arrows printed onto the handles.



smo2011-004-001\_a  
**PULL HANDLE UP (SEA-DOO MOVE I WITH WALK PADS SHOWN)**

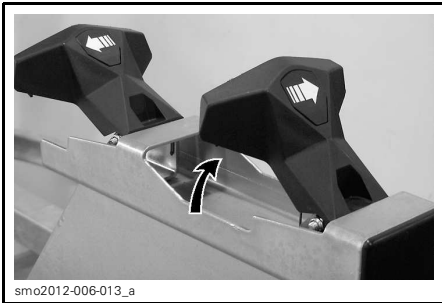

smo2012-006-013\_a  
**PULL HANDLE UP (SEA-DOO MOVE II)**

12. Once the watercraft has rolled off the trailer, start engine.

**NOTICE** Rocks, sand or other debris will be sucked into the watercraft propulsion system if engine is operated using too much throttle in shallow water.

13. Moor the watercraft.
14. Drive the tow vehicle out of the ramp.

15. Connect lights connector.

## Launching the Watercraft (Trailers with Winch)

1. Prepare the personal watercraft (PWC) for launching according to the PWC manufacturer's recommendations.
2. Remove tie-downs from stern and trailer eyelets.
3. Disconnect lights connector.
4. Make sure the way is clear behind the trailer (in and out of water).
5. Attach ropes to the watercraft mooring cleats and prevent them from hanging.
6. Have someone guiding you and back the vehicle until trailer reaches the desired depth into water.

**NOTE:** The PWC must not float above the bunks.

7. Hold the winch handle firmly and set winch mechanism to "unwind".

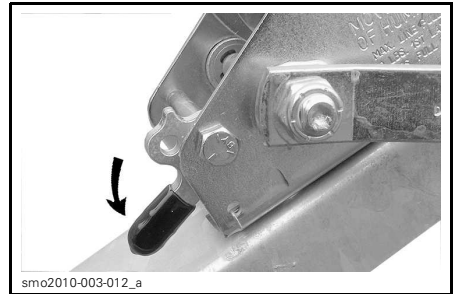

smo2010-003-012\_a  
**SET WINCH TO "UNWIND"**

8. Unwind until watercraft slides off the trailer and floats. It may be necessary to push the watercraft a little.
9. Grab the ropes previously attached to the mooring cleats, then moor the watercraft.
10. Drive the tow vehicle out of the ramp.
11. Connect lights connector.

# LOADING THE WATERCRAFT

## Loading the Watercraft (Trailers with iCatch)

1. Disconnect lights connector.
2. Make sure the iCatch system is unlocked and the applicable release handle is UP.



smo2010-005-004  
**UNLOCKED (HORIZONTAL)**



smo2011-004-001  
**HANDLE UP (SEA-DOO MOVE I WITH WALK PADS SHOWN)**

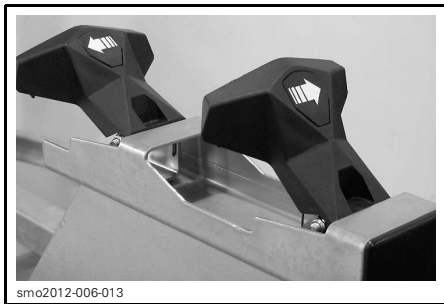

smo2012-006-013  
**HANDLES UP (SEA-DOO MOVE II)**

**⚠ WARNING**  
Always make sure the iCatch system is unlocked before loading the watercraft.

3. Have someone guiding you and back the vehicle until water level is within the water level decal upper and lower edges.



**WATER LEVEL DECAL**

**NOTE:** On very gentle slopes, water level may go over the decal zone, however, the PWC must not float above the rollers when watercraft contacts the iCatch mechanism.

4. Take place on the watercraft.
5. Put your personal flotation device (PFD) on and attach the safety lanyard to it.
6. Start engine and steer watercraft at idle speed to align it with the trailer rollers.

**NOTE:** If loading on a dual trailer, make sure you load the PWC on the same side it was launched. Match the decal on the iCatch frame with the one on your PWC (iCatch 1 or iCatch 2).





11. On both sides, secure rear of PWC to the trailer using suitable tie-downs attached to the stern eyelets and trailer eyelets together.

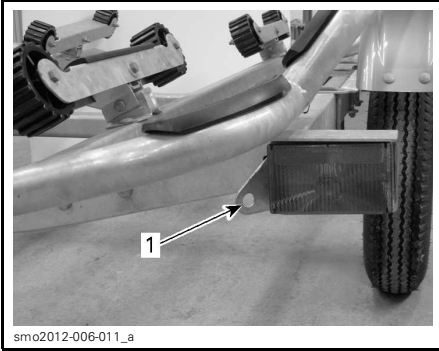

1. Trailer eyelets (Sea-Doo MOVE I)



1. Trailer eyelets (Sea-Doo MOVE II)

## **⚠ WARNING**

Before towing, make sure:

- PWC is securely latched at front.
- iCatch mechanism is locked.
- PWC is secured to the trailer at rear using tie-downs.
- PWC is secured to the trailer at front using the safety cable.

12. Connect lights connector.

## **Loading the Watercraft (Trailers with Winch)**

### **⚠ WARNING**

Make sure nobody stands on the walk pads when loading the watercraft.

1. Disconnect lights connector.
2. Have someone guiding you and back the vehicle until the trailer reaches the desired depth into water.

**NOTE:** Bunks should be immersed in water just enough for the watercraft to be dragged onto them without floating over them.

3. Align the watercraft with the trailer bunks.
4. Unwind the winch and attach the hook or strap to the watercraft's bow eyelet.
5. Set winch mechanism to "wind", then wind until watercraft bow reaches the trailer bow stop roller.

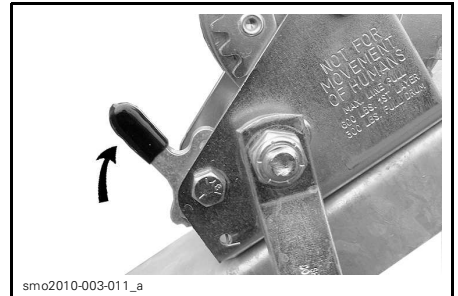

SET WINCH TO "WIND"

6. Drive the tow vehicle out of the ramp.
7. Secure personal watercraft (PWC) on the trailer using suitable tie-downs attached to the stern eyelets and trailer eyelets together.

LOADING THE WATERCRAFT

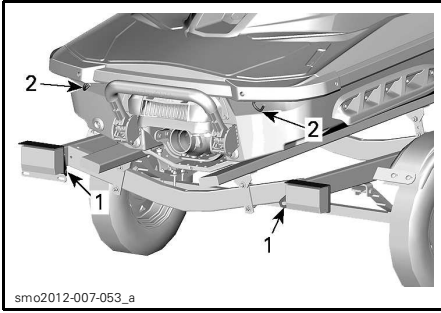

**TYPICAL - MOVE I**

1. Trailer eyelets
2. Watercraft eyelets

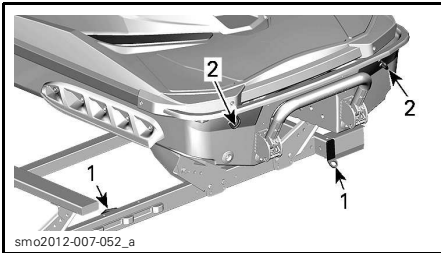

**TYPICAL - MOVE II**

1. Trailer eyelets
2. Watercraft eyelets

8. Connect lights connector.

# ***TECHNICAL INFORMATION***

# TRAILER IDENTIFICATION NUMBER

The trailer is identified by a serial number. It may sometimes become necessary to locate this number for warranty purposes or to trace the trailer in the event of theft. The serial number is located on the Technical Information label and is also engraved on the tongue of the trailer.

MFD BY/FABRIQUE PAR: KARAVAN TRAILERS INC.

DATE: June 2011      MADE IN USA      JOB# 284645

PNBV / GVWR		PNBE / GAWR		TIRE/PNEU	COLD INFL. PRESSURE		MAX. LOAD CARRYING CAP		RIM
KG	LB	KG	LB		KPA	PSI	KG	LB	
671	1479	671	1479	4.80 X 12B	413	60	522	1150	12x4
0									

THIS VEHICLE CONFORMS TO ALL APPLICABLE U.S. FEDERAL MOTOR VEHICLE SAFETY STANDARDS (FMVSS) IN EFFECT ON THE DATE OF MANUFACTURE SHOWN ABOVE. THIS VEHICLE CONFORMS TO ALL APPLICABLE STANDARDS PRESCRIBED UNDER THE CANADIAN MOTOR VEHICLE SAFETY REGULATIONS IN EFFECT ON THE DATE OF MANUFACTURE SHOWN ABOVE. / CE VEHICULE EST CONFORME A TOUTES LES NORMES QUI LUI SONT APPLICABLES EN VERTU DU REGLEMENT SUR LA SECURITE DES VEHICULES AUTOMOBILES DU CANADA EN VIGUEUR A LA DATE DE SA FABRICATION.

TYPE: /TRA/REM WATERCRAFT TRAILER      WCE-1250-46

5KTWS1419CF002080

sno2012-006-002\_a

1. Serial number

# SPECIFICATIONS

MODEL	MOVE I EXTENDED 1250	MOVE I EXTENDED 1500	MOVE I	MOVE I WITH iCATCH AND WALK PADS
<b>SUSPENSION</b>				
Type	Leaf spring	Leaf spring	Torsion and leaf spring	Torsion
<b>DIMENSIONS</b>				
Overall length	4.1 m (13.5 ft)	4.1 m (13.5 ft)	3.8 m (12.5 ft)	4.1 m (13.5 ft)
Overall width	1.5 m (4.9 ft)	1.7 m (5.5 ft)	1.5 m (4.9 ft)	1.8 m (5.9 ft)
Width between fenders <sup>(1)</sup>	1.2 m (3.9 ft)	1.2 m (3.9 ft)	1.2 m (3.9 ft)	N.A.
Width between walk pads <sup>(1)</sup>	N.A.	N.A.	N.A.	1.3 m (4.3 ft)
Width between rails	N.A.	N.A.	N.A.	N.A.
Overall height (iCatch) <sup>(3)</sup>	N.A.	N.A.	N.A.	107 cm (42.1 in)
Overall height (walk pad) <sup>(2)</sup>	N.A.	N.A.	N.A.	90 cm (35 in)
Overall height (rails)	N.A.	N.A.	N.A.	N.A.
Overall height (fender) <sup>(2)</sup>	61 cm (24 in)	70 cm (27.5 in)	61 cm (24 in)	N.A.
Overall height (winch) <sup>(3)</sup>	80 cm (31 in)	80 cm (31 in)	80 cm (31 in)	N.A.
Coupler ball size	5 cm (2 in)			
<b>WEIGHT AND LOAD LIMITS</b>				
Approximate dry weight	113 kg (250 lb)	125 kg (275 lb)	105 kg (231 lb)	163 kg (359 lb)
Carrying capacity	567 kg (1,250 lb)	682 kg (1,500 lb)	560 kg (1,235 lb)	519 kg (1,144 lb)

**SPECIFICATIONS**

<b>MODEL</b>	<b>MOVE I EXTENDED 1250</b>	<b>MOVE I EXTENDED 1500</b>	<b>MOVE I</b>	<b>MOVE I WITH iCATCH AND WALK PADS</b>
<b>TIRES AND WHEELS</b>				
Tire size	4.8 x 12B (in)	5.3 x 12C (in)	4.8 x 12B (in)	
Wheel size	4.8 x 12B (in)	5.3 x 12C (in)	4.8 x 12B (in)	
Cold pressure	413 kPa (60 PSI)	550 kPa (80 PSI)	413 kPa (60 PSI)	
Lug nuts torque	116 N•m ± 6 N•m (86 lbf•ft ± 4 lbf•ft)			
Minimum thread depth	1.6 mm (1/16 in)			
(1) Maximum PWC width (2) Tongue on the ground (3) Hitch coupler 41 cm (16 in) above the ground N.A.: Not Available				

MODEL	MOVE II	SEA-DOO MOVE II WITH iCATCH	SPARK™ MOVE II
<b>SUSPENSION</b>			
Type	Leaf spring	Torsion	Leaf spring
<b>DIMENSIONS</b>			
Overall length	5.18 m (17 ft)		3.78 m (12.5 ft)
Overall width	2.5 m (8.2 ft)	2.6 m (8.5 ft)	
Width between fenders <sup>(1)</sup>	2.1 m (6.9 ft)	N.A.	2.23 m (7 ft)
Width between rails	N.A.	119 cm (46.9 in)	N.A.
Overall height (iCatch) <sup>(3)</sup>	N.A.	1.2 m (3.9 ft)	N.A.
Overall height (rails)	N.A.	1.3 m (4.3 ft)	N.A.
Overall height (rails)	N.A.	90 cm (35 in)-	N.A.
Overall height (fender) <sup>(2)</sup>	74 cm (29 in)	N.A.	60 cm (24 in)
Overall height (winch) <sup>(3)</sup>	99 cm (39 in)	N.A.	87 cm (34 in)
Coupler	5 cm (2 in)		
<b>WEIGHT AND LOAD LIMITS</b>			
Approximate dry weight	220 kg (485 lb)	268 kg (591 lb)	154 kg (340 lb)
Carrying capacity	1 114 kg (2,456 lb)	1 070 kg (2,359 lb)	553 kg (1,220 lb)
<b>TIRES AND WHEELS</b>			
Tire size	ST185/80D13C		4.80 X 12B (in)
Wheel size	ST175/80D13 5H		4.80 X 12B (in)
Cold pressure	345 kPa (50 PSI)		413 kPa (60 PSI)
Lug nuts torque	116 N•m ± 6 N•m (86 lbf•ft ± 4 lbf•ft)		
Minimum thread depth	1.6 mm (1/16 in)		
(1) Maximum PWC width (2) Tongue on the ground (3) Hitch coupler 41 cm (16 in) above the ground N.A.: Not Available			

---

## REPORTING SAFETY DEFECTS

Your safety is very important to Bombardier Recreational Products Inc. (BRP). If you have any concerns you should immediately contact BRP's customer service.

In the USA, if you believe that your vehicle has a defect which could cause a crash or could cause injury or death, you should immediately inform the National Highway Traffic Safety Administration (NHTSA) in addition to notifying Bombardier Recreational Products Inc.

If NHTSA receives similar complaints, it may open an investigation, and if it finds that a safety defect exists in a group of vehicles, it may order a recall and remedy campaign. However, NHTSA cannot become involved in any individual problems between you, your dealer or Bombardier Recreational Products Inc.

To contact NHTSA:

**By phone:** Safety Hotline toll-free:  
1 888-327-4236 (TTY: 1 800-424-9153)

**By E-mail:** [www.safercar.gov](http://www.safercar.gov)

**By mail:** Administrator  
NHTSA  
400 7<sup>th</sup> Street SW  
Washington, DC 20590

You can also obtain other information about motor vehicle safety from the website:  
[www.safercar.gov](http://www.safercar.gov)



# ***MAINTENANCE***

---

# MAINTENANCE SCHEDULE

Maintenance is very important for keeping your trailer in safe operating condition.

The maintenance schedule does not exempt the pre-use inspection.

**NOTE:** If trailer is used all year round, carry out both *STORAGE* and *PRE-SEASON* maintenance operations once a year.

## At Storage

Carry out the following at trailer storage:

- Tighten loose fasteners and connections.
- Inflate tires to recommended pressure.
- Check coupler condition and lubricate.
- Lubricate jack.
- Apply DIELECTRIC GREASE (P/N 293 550 004) in all electric connectors and light bulb socket to prevent corrosion.
- Trailers with winch: Check winch and strap condition. Lubricate winch mechanism.
- If possible, park trailer in a protected area, garage, carport, etc.
- Raise trailer and place blocks under trailer frame to take most of the weight off the suspension and tires.

## At Preseason

Carry out the following before using trailer after a storage period:

- Inspect wheels for damage.
- Check tightness of all fasteners.
- Check wheel bearing and seals.
- Trailers with iCatch: Have the iCatch mechanism(s), release cable(s) and release handle(s) condition checked by an authorized Sea-Doo dealer.
- Check wiring harness condition.
- Inspect safety cable.

# MAINTENANCE PROCEDURES

This section includes instructions for basic maintenance procedures. If you have the necessary mechanical skills and the required tools, you can perform these procedures. If not, see your authorized Sea-Doo dealer.

## WARNING

Torque wrench tightening specifications must be strictly adhered to.  
Locking devices, when removed (e.g.: locking tabs, elastic stop nuts, cotter pins, etc.), must be replaced.

Hoses, cables or locking ties removed during a procedure must be reinstalled as per factory standards.

## Safety Cable

### Safety Cable Inspection

Inspect cable for damage.

Discontinue use and contact an authorized Sea-Doo dealer if cable or its liner are damaged.

## WARNING

Do not use the trailer if safety cable is damaged.

## Coupler

### Coupler Inspection and Lubrication

Check locking mechanism operation.

Check ball socket, ball clamp and lock mechanism for wear or damage.

Apply a thin coat of multipurpose grease to the inner surface of the ball socket.

Apply light oil to the pivot and sliding surface of the lock mechanism.

## Tires

### Tire Pressure

Check tire pressure. Tire pressure must be checked while the tire is cold.

**NOTE:** Do not check the tire pressure immediately after towing the trailer. Allow at least three hours for a tire to cool down, if the trailer has been towed for as much as 1.6 km (1 mi).

TIRE PRESSURE			
COLD TIRE	MOVE II	MOVE I EXTENDED 1500	MOVE I MOVE I EXTENDED 1250 SPARK™ MOVE II
	345 kPa (50 PSI)	550 kPa (80 PSI)	413 kPa (60 PSI)

### Tire Inspection

Replace the tire before towing the trailer if the tire tread has less than 1.6 mm (1/16 in) depth or if the built-in wear indicator bars are visible and flush with the remainder of the tire tread.

Always replace a tire with one of the same dimensions and load limit.

Inspect both sidewalls of each tire for any bubble, cut or bulge; and replace a damaged tire before towing the trailer.

## WARNING

A bubble, cut or bulge in the sidewall can result in a tire blowout and loss of control.

## Wheels

### Wheel Inspection

Check wheel for cracks, bumps or other damages. Replace wheel as required.

## Wheel Bearings and Seals

### Wheel Bearing Inspection

Install a jack under the axle and raise until the tire gets off the ground.

Push and pull the wheel from the upper edge to feel the play and rotate wheel.

If any play is felt or if wheel does not turn smoothly, have the wheel bearing replaced.

### Wheel Bearing Seal Inspection

A slight film of grease around the seal is normal. Have the seal replaced if an excessive leak or damage is noticed.

## Lights

### Light Bulb Replacement

#### Taillights and Rear Side Markers

1. Remove the clear lens located underneath the taillight lens.

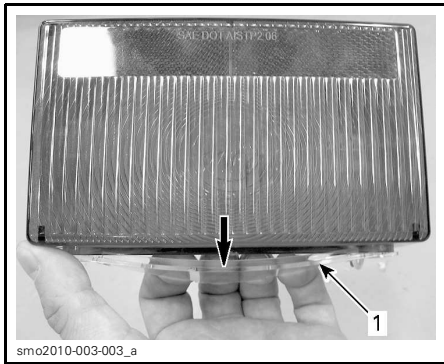

**PULL CLEAR LENS DOWN**

1. Clear lens

2. Replace burnt light bulb.

To remove the stop/turn/parking light bulb, push the bulb in and turn counterclockwise. To install, index the bulb base with the socket, push in, then turn to lock it in place.

To remove side marker light bulb, pry it off its socket. To install, push the bulb in the socket until it bottoms. There is no indexation for that type of bulb.

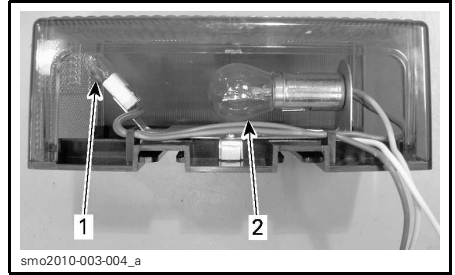

1. Marker light bulb
2. Stop/turn/parking light bulb

3. Install clear lens:

- 3.1 Insert the wires in the clear lens slot.
- 3.2 On both sides, insert the clear lens center tab behind the red lens and the outer tabs over the red lens.

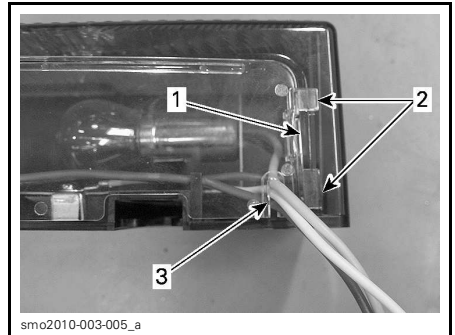

1. Center tab
2. Outer tabs
3. Slot

### Front Side Markers

1. Pry lens off by twisting a flat screwdriver into the light housing slot.

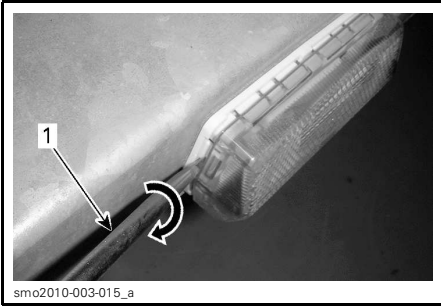

**PRY LENS OFF**

1. Flat screwdriver

2. Pull burnt bulb off its socket.
3. Push a new bulb into the socket until it bottoms. There is no indexation for that type of bulb.
4. Push lens back in place.

**Winch**

**Winch Inspection**

Inspect gears, bushings and strap for wear or damage.

**Winch Lubrication**

Apply a thin coat of multipurpose grease to the gearing teeth and pivot points. Rotate handle to distribute grease evenly.

Lubricate ratchet pivot point with light oil.

**Jack**

**Jack Lubrication**

Clean grease fitting, then lubricate using multipurpose grease. Rotate handle to distribute grease evenly.

Lubricate handle pivot point and wheel axle with light oil. Wipe excess oil and rotate parts to distribute oil evenly.

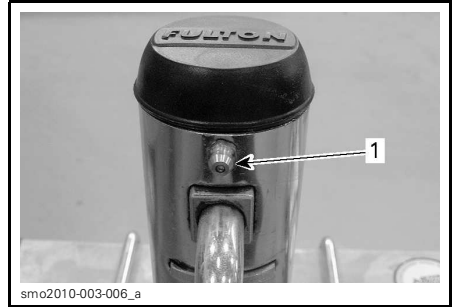

1. Grease fitting

**Wooden Bunks (Sea-Doo MOVE I and II Trailers with Winch)**

Check wooden bunks carpet condition and wood hardness.

**Rollers (Trailers with iCatch)**

Check rollers for wear, cracks or damage.

---

## TRAILER CARE

### Salt Water Use

If trailer used in salt water, thoroughly rinse trailer daily with fresh water.

### Trailer Cleaning

1. Rinse the trailer thoroughly with fresh water to remove loose dirt.
2. Using a soft, clean cloth, wash the trailer with water mixed with a mild detergent, such as soap specially formulated for motorcycles or automobiles.
3. While washing the trailer, check for grease or oil. An automotive grease remover can be used. Thoroughly follow the manufacturer's instructions.
4. Dry the trailer with a chamois or a soft towel.

 **CAUTION** Never use any kind of vinyl or plastic protector on the walk pads as they would get slippery.

# ***WARRANTY***

---

# **BRP LIMITED WARRANTY USA AND CANADA: 2014 SEA-DOO MOVE™ PWC TRAILER**

## **1. SCOPE OF THE LIMITED WARRANTY**

Bombardier Recreational Products Inc. ("BRP")™\* warrants its 2014 Sea-Doo MOVE™ PWC trailer ("Trailer") sold by authorized Sea-Doo Dealers (as defined hereinafter) in the fifty United States and in Canada from defects in material or workmanship for the period and under the conditions described below. This limited warranty will become null and void if the Trailer has been altered or modified in such a way so as to adversely affect its operation, performance or durability, or has been altered or modified to change its intended use.

All genuine Trailer parts and accessories installed on the Trailer by an authorized Sea-Doo Dealer at the time of delivery of the Trailer will carry the same warranty as that of the Trailer.

## **2. LIMITATIONS OF LIABILITY**

**THIS WARRANTY IS EXPRESSLY GIVEN AND ACCEPTED IN LIEU OF ANY AND ALL OTHER WARRANTIES, EXPRESSED OR IMPLIED, INCLUDING WITHOUT LIMITATION ANY WARRANTY OF MERCHANTABILITY OR FITNESS FOR A PARTICULAR PURPOSE. TO THE EXTENT THAT THEY CANNOT BE DISCLAIMED, THE IMPLIED WARRANTIES ARE LIMITED IN DURATION TO THE LIFE OF THE EXPRESS WARRANTY. INCIDENTAL AND CONSEQUENTIAL DAMAGES ARE EXCLUDED FROM COVERAGE UNDER THIS WARRANTY. SOME STATES/PROVINCES DO NOT ALLOW FOR THE DISCLAIMERS, LIMITATIONS AND EXCLUSIONS IDENTIFIED ABOVE, AS A RESULT, THEY MAY NOT APPLY TO YOU. THIS WARRANTY GIVES YOU SPECIFIC RIGHTS, AND YOU MAY ALSO HAVE OTHER LEGAL RIGHTS WHICH MAY VARY FROM STATE TO STATE, OR PROVINCE TO PROVINCE.**

Neither the distributor, any Sea-Doo Dealer nor any other person has been authorized to make any affirmation, representation or warranty regarding the Trailer, other than those contained in this limited warranty, and if made, shall not be enforceable against BRP. BRP reserves the right to modify this warranty at any time, being understood that such modification will not alter the warranty conditions applicable to the Trailer sold while this warranty is in effect.

## **3. EXCLUSIONS – ARE NOT WARRANTED**

The following are not warranted under any circumstances:

- Replacement of routine maintenance items including the performance of adjustments.
- Normal wear and tear.
- Damages related to the appearance of the Trailer, including without limitation scratches, dents, fading, flaking, and peeling.
- Damage caused by failure to provide proper maintenance or storage, as described in the Operator's Guide.
- Damage resulting from removal of parts, improper repairs, improper service or improper maintenance, modifications, alterations that are outside of the original specifications of the Trailer, or damage resulting from repairs done by a person that is not an authorized servicing Sea-Doo Dealer.



- Damage resulting from the installation of parts with specifications that differ from the original Trailer parts, such as, without limitation, different tires or wheels.
- Damage resulting from abuse, abnormal use, or neglect.
- Damage resulting from accident, road hazards, submersion, fire, theft, vandalism or any act of God.
- Damage resulting from corrosion from road salts, environmental influences or treatment contrary to the Operator’s Guide.
- Incidental or consequential damages, including without limitation towing, storage, telephone, rental, taxi, inconvenience, insurance coverage, loan payments, loss of time, loss of income.
- Any cost of transportation or shipping incurred in respect of the performance of this warranty.

#### **4. WARRANTY COVERAGE PERIOD**

This warranty will be in effect from the date of delivery to the first retail consumer or the date the Trailer is first put into use, whichever occurs first and for the following periods:

1. **TWELVE (12) CONSECUTIVE MONTHS** for private, recreational use, except that the frame is covered for **SIXTY (60) CONSECUTIVE MONTHS**;
2. **FOUR (4) CONSECUTIVE MONTHS** for commercial use, except that the frame is covered for **TWELVE (12) CONSECUTIVE MONTHS**.

A Trailer is used commercially when it is used in connection with any work or employment that generates income, during any part of the warranty period. A Trailer is also used commercially when, at any point during the warranty period, it is licensed for commercial use.

The repair or replacement of parts or the performance of service under this warranty does not extend the life of this warranty beyond its original expiration date.

#### **5. CONDITIONS REQUIRED FOR WARRANTY COVERAGE**

- The Trailer must be purchased as new and unused by its first owner from a Sea-Doo dealer authorized to distribute Trailers in the country in which the sale occurred (“Sea-Doo Dealer”).
- The BRP specified pre-delivery inspection process must be completed, documented and signed by the purchaser.
- The Trailer must have undergone proper warranty registration by an authorized Sea-Doo Dealer.
- The Trailer must be purchased in the country in which the purchaser resides.
- Routine maintenance must be performed as indicated in the Operator’s Guide. BRP reserves the right to make warranty coverage contingent upon proof of proper maintenance.

BRP will not honor this limited warranty to any private use owner or commercial use owner if one of the preceding conditions has not been met. Such limitations are necessary in order to allow BRP to preserve both the safety of its products, and also that of its consumers and the general public.

## **6. WHAT TO DO TO OBTAIN WARRANTY COVERAGE**

The customer must cease using the Trailer upon the appearance of an anomaly. The customer must notify a servicing Sea-Doo Dealer within two (2) days of the appearance of a defect, and provide it with reasonable access to the product and reasonable opportunity to repair it. The customer must also present to the authorized Sea-Doo Dealer proof of purchase of the product and must sign the repair/work order prior to starting the repair in order to validate the warranty repair. All parts replaced under this limited warranty become the property of BRP.

## **7. WHAT BRP WILL DO**

BRP's obligations under this warranty are limited to, at its sole discretion, repairing parts found defective under normal use, maintenance and service, or replacing such parts with new genuine Trailer parts without charge for parts and labor, at any authorized Sea-Doo Dealer during the warranty coverage period. No claim of breach of warranty shall be cause for cancellation or rescission of the sale of the Trailer to the owner.

In the event that service is required outside of the country of original sale, the owner will bear responsibility for any additional charges due to local practices and conditions, such as, but not limited to, freight, insurance, taxes, license fees, import duties, and any and all other financial charges, including those levied by governments, states, territories and their respective agencies.

BRP reserves the right to improve or modify products from time to time without assuming any obligation to modify any products previously manufactured.

## **8. TRANSFER**

If the ownership of a Trailer is transferred during the warranty coverage period, this warranty shall also be transferred and be valid for the remaining coverage period provided that BRP is notified of such transfer of ownership in the following way:

1. The former owner contacts BRP (at the phone number provided below) or an authorized Sea-Doo Dealer and gives the coordinates of the new owner; or
2. BRP or an authorized Sea-Doo Dealer receives a proof that the former owner agreed to the transfer of ownership, in addition to the coordinates of the new owner.

## 9. CONSUMER ASSISTANCE

In the event of a controversy or a dispute in connection with this limited warranty, BRP suggests that you try to resolve the issue at the dealership level. We recommend discussing the issue with the authorized Sea-Doo Dealer's service manager or owner.

If the issue has not yet been resolved, please submit your complaint in writing or call the appropriate number below:

### **In Canada:**

**BOMBARDIER RECREATIONAL  
PRODUCTS INC.**  
SEA-DOO  
CUSTOMER ASSISTANCE CENTER  
75 J.-A. Bombardier Street  
Sherbrooke QC J1L 1W3  
Tel: 819 566-3366

### **In USA:**

**BRP US INC.**  
SEA-DOO  
CUSTOMER ASSISTANCE CENTER  
7575 Bombardier Court  
Wausau WI 54401  
Tel: 715 848-4957

\* In the USA, products are distributed and serviced by BRP US Inc.  
© 2013 Bombardier Recreational Products Inc. All rights reserved.  
™ Trademarks of Bombardier Recreational Products Inc. or its affiliates.  
® Registered trademarks of Bombardier Recreational Products Inc.

***This page is  
intentionally blank***

# ***CUSTOMER INFORMATION***

---

## **PRIVACY INFORMATION**

BRP wishes to inform you that your coordinates will be used for safety and warranty related purposes. Furthermore, BRP and its affiliates may use its customer list to distribute marketing and promotional information about BRP and related products.

To exercise your right to consult or correct your data, or to be removed from the addressee-list for direct marketing, please contact BRP.

**By E-mail:** [privacyofficer@brp.com](mailto:privacyofficer@brp.com)

**By mail:** BRP  
Senior Legal Counsel-Privacy Officer  
726 St-Joseph  
Valcourt Quebec  
Canada,  
J0E 2L0

---

## CHANGE OF ADDRESS/OWNERSHIP

If your address has changed or if you are the new owner of the trailer, be sure to notify BRP by either:

- Mailing one of the following card below;
- **North America only:** calling at 715 848-4957 (USA) or 819 566-3366 (Canada);
- Contacting an authorized BRP distributor/dealer.

In case of change of ownership, please join a proof that the former owner agreed to the transfer.

Notifying BRP, even after the expiration of the limited warranty, is very important as it enables BRP to reach the trailer owner if necessary, like when safety recalls are initiated. It is the owner's responsibility to notify BRP.

**STOLEN UNITS:** In the event that your trailer is stolen, you should notify your area's distributor warranty department of such. We will ask you to provide your name, address, phone number, Hull Identification Number and date it was stolen.

### **In North America**

#### **BOMBARDIER RECREATIONAL PRODUCTS INC.**

Warranty Department  
75 J.-A. Bombardier Street  
Sherbrooke QC J1L 1W3  
Canada

### **Other Areas in The World Except Scandinavian Countries**

#### **BRP EUROPEAN DISTRIBUTION**

Warranty Department  
Chemin de Messidor 5-7  
1006 Lausanne  
Switzerland

### **Scandinavian Countries**

#### **BRP FINLAND OY**

Service Department  
Isoaavantie 7  
FIN-96320 Rovaniemi  
Tel.: +358 16 3208 111

***This page is  
intentionally blank***









219 001 363

CA

USER'S GUIDE, SEA-DOO MOVE TRAILER / ENGLISH  
GUIDE DE L'UTILISATEUR, REMORQUE SEA-DOO MOVE / ANGLAIS

FAIT AU / MADE IN CANADA

U/M:P.C.