



2010

ADVANCED TEC™
PWC Trailer
USER'S GUIDE

⚠ WARNING

Read this User's guide.
It contains important safety information.
Keep this User's Guide for reference.

2 1 9 0 0 0 7 4 7



WARNING

Disregarding any of the safety precautions and instructions contained in this guide and on-product labels could cause injury including the possibility of death!

In Canada, products are distributed by Bombardier Recreational Products Inc. (BRP).

In USA, products are distributed by BRP US Inc.

Knight's Spray-Nine[†] is a registered trademark of Korkay System Ltd.

GTX[†] is a registered trademark of Castrol Ltd. used under license.

This is a non-exhaustive list of trademarks that are the property of Bombardier Recreational Products Inc. or its affiliates:

ADVANCED TEC™

iS™

Sea-Doo®

iCatch™

RXP™

S³ hull™

GTI™

RXT™

Wake™

INTRODUCTION

Congratulations on your purchase of your new BRP Sea-Doo™ ADVANCED TEC™ trailer. It is backed by the BRP warranty and a network of authorized Sea-Doo personal watercraft (PWC) dealers ready to provide the parts or service you may require.

Know Before You Go

Read this guide and follow all instructions before installing or using this product.

Read all on-product safety labels carefully and follow the operating procedures described.

Failure to follow the warnings contained in this User's Guide can result in SERIOUS INJURY or DEATH.

About this User's Guide

The following guide will help you become better acquainted with your new trailer and its safe operation.

Keep this User's Guide in the tow vehicle so you can refer to it.

If you want to view and/or print an extra copy of this User's Guide, simply visit the following website:

www.operatorsguide.brp.com

It is understood that this User's Guide may be translated into another language. In the event of any discrepancy, the English version shall prevail.

The information and components/system descriptions contained in this document are correct at the time of publication. Bombardier Recreational Products Inc., however, maintains a policy of continuous improvement of its products without imposing upon itself any obligation to install them on products previously manufactured. Due to late changes, some differences between the manufactured product and the descriptions and/or specifications in this guide may occur. BRP reserves the right at any time to discontinue or

change specifications, designs, features or equipment without incurring any obligation upon itself.

The illustrations in this document show the typical construction of the different assemblies and may not reproduce the full detail or exact shape of the parts. However, they represent parts that have the same or similar function.

Safety Messages

The types of safety messages, what they look like and how they are used in this guide are explained as follows:

 WARNING
Indicates a potential hazard which, if not avoided, could result in serious injury or death.

 **CAUTION** Indicates a hazard situation which, if not avoided, could result in minor or moderate injury.

 **NOTICE** Indicates an instruction which, if not followed, could severely damage trailer components or other property.

TABLE OF CONTENTS

INTRODUCTION	1
Know Before You Go	1
About this User's Guide	1
Safety Messages	1

SAFETY INFORMATION

SPECIAL SAFETY MESSAGES	6
Important Warnings	6
Important Information	6
LOCATION OF THE SAFETY LABELS	7
SAFETY PRECAUTIONS WHEN TRAILER IS NOT IN USE	10
Immobilizing Trailer for Parking	10

OPERATING INSTRUCTIONS

TRAILER SET-UP	12
Fitting the Trailer to the Watercraft (ADVANCED TEC iCatch)	12
Fitting the Trailer to the Watercraft (ADVANCED TEC)	17
BEFORE GETTING UNDERWAY	19
Attaching the Trailer to the Tow Vehicle	19
Pre-Use Inspection	21
TOWING THE TRAILER	22
LAUNCHING THE WATERCRAFT	23
Launching the Watercraft (ADVANCED TEC iCatch)	23
Launching the Watercraft (ADVANCED TEC)	24
LOADING THE WATERCRAFT	26
Loading the Watercraft (ADVANCED TEC iCatch)	26
Loading the Watercraft (ADVANCED TEC)	28

TECHNICAL INFORMATION

TRAILER IDENTIFICATION NUMBER	32
TECHNICAL INFORMATION LABELS	33
SPECIFICATIONS	34

MAINTENANCE

MAINTENANCE SCHEDULE	36
At Storage	36
At Pre-Season	36
MAINTENANCE PROCEDURES	37
Safety Cable	37

MAINTENANCE PROCEDURES (cont'd)	
Coupler	37
Tires	37
Wheels	37
Wheel Bearings and Seals	37
Lights	38
Winch	39
Jack	39
Wooden Bunks (ADVANCED TEC)	39
Rollers (ADVANCED TEC iCatch)	39
TRAILER CARE	40
Salt Water Use	40
Trailer Cleaning	40

WARRANTY

BRP LIMITED WARRANTY - USA AND CANADA: 2010 SEA-DOO® ADVANCED TEC™ PWC TRAILER	42
BRP LIMITED WARRANTY - INTERNATIONAL: 2010 SEA-DOO® ADVANCED TEC™ PWC TRAILER	46
BRP LIMITED WARRANTY FOR THE EUROPEAN ECONOMIC AREA: 2010 SEA-DOO® ADVANCED TEC™ PWC TRAILER	50
ADDITIONAL TERMS AND CONDITIONS FOR FRANCE ONLY	54

CUSTOMER INFORMATION

PRIVACY INFORMATION	56
CHANGE OF ADDRESS/OWNERSHIP	57

SAFETY INFORMATION

SPECIAL SAFETY MESSAGES

Important Warnings

Always perform the *PRE-USE INSPECTION* for safe driving.

Always follow guidelines in *TOWING THE TRAILER*.

Maintain your trailer as per the *MAINTENANCE SCHEDULE*.

Important Information

Trailer

This BRP Sea-Doo ADVANCED TEC trailer has been specially designed to carry a personal watercraft (PWC).

WARNING

iCatch™ mechanism must be specifically adjusted to the personal watercraft (PWC) model and used exclusively with the iCatch bow cup. An incorrect adjustment may cause the iCatch mechanism to inadequately secure the personal watercraft (PWC) to the trailer.

Hitch

WARNING

The use of a hitch with an insufficient load rating can result in hitch breakdown.

Be sure the hitch ball size matches the coupler size.

Inspect the hitch for wear, corrosion and cracks before coupling. Replace the required components if any of the above conditions is observed.

WARNING

Do not tow whenever a component is defective.

NOTICE The coupling socket should not be allowed to rest on the ground where dirt and sand can enter the socket. This will lead to excessive wear or cause the locking mechanism to jam.

Ensure hitch is tight before coupling the trailer to the vehicle.

WARNING

An improperly coupled trailer can result in a loss of control or serious road hazard. Never use the trailer pre-use inspection is completed.

Tow Vehicle

Some vehicles are not intended to tow a trailer. Make sure your vehicle is designed to tow a trailer and its towing capacity is sufficient.

WARNING

Never tow this trailer with a vehicle not intended for trailer towing or with an insufficient towing capacity.

Accessories and Modifications

We recommend to use replacement parts and accessories from BRP. They've been especially designed for your trailer and manufactured to meet BRP's demanding standards.

Do not make unauthorized modifications, or use accessories that are not approved by BRP. Since these changes have not been tested by BRP, they may increase the risk of accidents or injuries, and they can make the trailer illegal for use.

LOCATION OF THE SAFETY LABELS

The following labels are on your trailer. If missing or damaged, they can be replaced free of charge. See an authorized Sea-Doo personal watercraft (PWC) dealer.

Please read the following labels carefully before using your trailer.

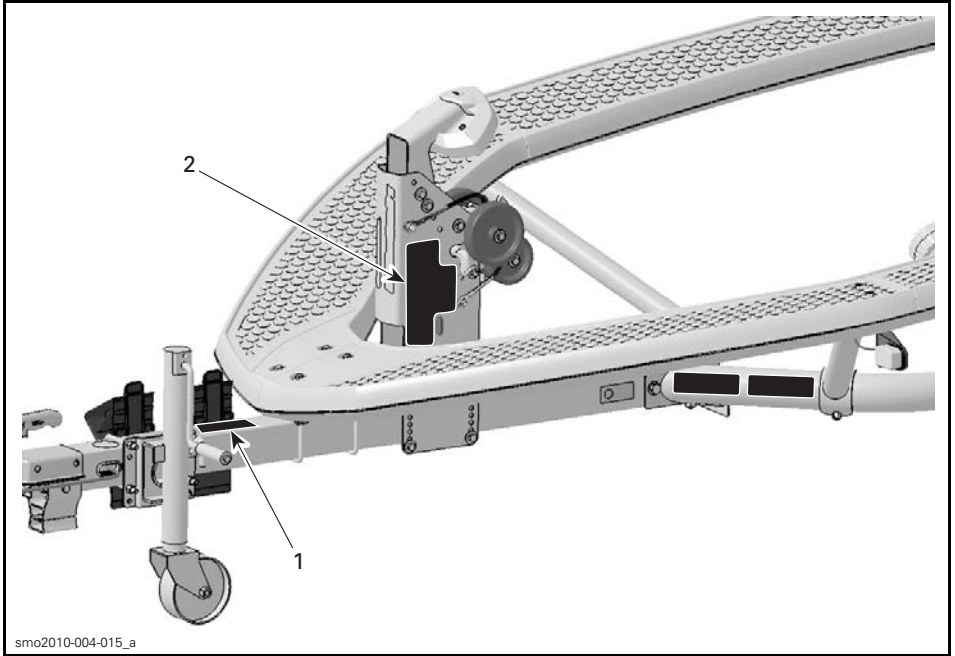

TYPICAL

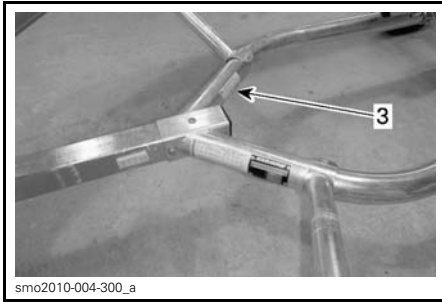

TYPICAL

⚠ WARNING

Serious injury or death can result if this trailer is towed before familiarizing yourself with the manufacturer's operation instructions listed below.

Do not exceed the tow vehicle's "tow rating" or exceed the GVWR or GCWR.

219903238

⚠ WARNING

Before towing this trailer check that:

- Coupler hitch and trailer ball are the same size. Coupler is latched. Safety chains are crisscrossed under tongue and attached to towing vehicle.
- All trailer lighting is working correctly. Load is secured to trailer (front and rear).
- Tongue jack (if trailer is equipped) is retracted.
- Wheel lug bolts are properly tightened. Tires are inflated to pressure indicated on tire.
- Load is within trailer capacity and distributed properly to maintain proper tongue weight.

You are required to comply with local and state requirements regarding brakes, licensing and any additional equipment that may be necessary. Contact your state motor vehicle department for more information.

219 903 238

LABEL 1

TO LOCK:

1 FULLY TURN CCW



2 INSERT TO LOCK



TO UNLOCK: PULL AND TURN CW

⚠ WARNING

ALWAYS MAKE SURE THAT THE:

- iCatch system is properly adjusted to fit the PWC.
- iCatch lever is in the UNLOCK position to load or unload the PWC.

BEFORE TOWING WHEN A PWC IS LATCHED INTO THE iCatch:

- Make sure the PWC is securely latched in the front.
- Secure iCatch hook by turning lever to the LOCK position.
- Route the loose end of the safety cable through iCatch bow cup and fasten to the pin adaptor on the iCatch frame and secure with the locking hair pin .
- Fasten the stern of the watercraft with 2 ratchet type tie down straps, one on each side.

Never stand on the walk board while PWC is loading on the trailer. Walk board is designed to support a person of 160 kg (350 lb) MAX. Refer to your user's guide for more details.



PATENT PENDING
262000116A

262000116A

LABEL 2 (ADVANCED TEC iCATCH ONLY)



TIRE AND LOADING INFORMATION
RENSEIGNEMENTS SUR LES PNEUS ET LE CHARGEMENT

The weight of cargo should never exceed **544 kg or 1200 lbs.**
Le poids du chargement ne doit jamais dépasser **kg or lb.**

TIRE PNEU	SIZE DIMENSIONS	COLD TIRE PRESSURE PRESSION DES PNEUS EA FROID	SEE OWNER'S MANUAL FOR ADDITIONAL INFORMATION VOIR LE MANUEL DE L'USAGER POR PLUS DE RENSEIGNEMENTS
FRONT AVANT	5.00 X 10B	351 kPA 51 PSI	
REAR ARRIERE			
SPARE DE SECOURS	NONE		

smo2010-004-100

LABEL 3

SAFETY PRECAUTIONS WHEN TRAILER IS NOT IN USE

Immobilizing Trailer for Parking

Use the following procedure when parking trailer.

1. Remove wheel blocks from tongue as follows:
 - 1.1 Push upper tab.
 - 1.2 Lift wheel block upwards while tilting it outward.

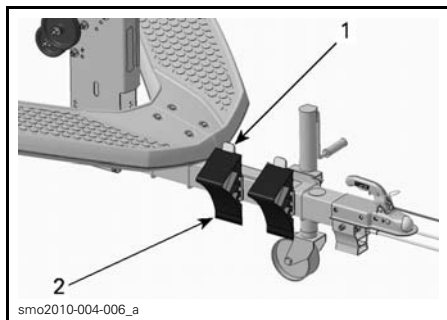

1. Upper tab
2. Wheel block

2. Immobilize trailer with wheel blocks in accordance with the following conditions.

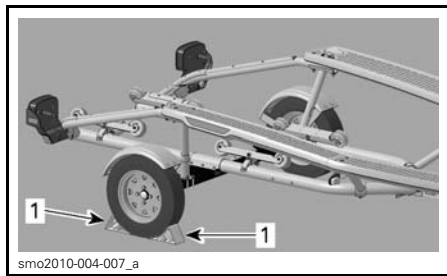

TRAILER PARKED ON A LEVEL SURFACE
1. Wheel blocks

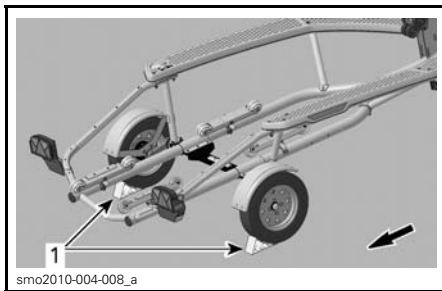

TRAILER PARKED FACING AN UP SLOPE
1. Wheel blocks

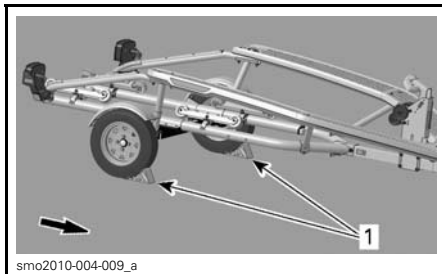

TRAILER PARKED FACING A DOWN SLOPE
1. Wheel blocks

3. Detach trailer from the tow vehicle.
 - Detach lights connector from vehicle.
 - Detach tongue safety cables or chains from vehicle.
 - Detach coupler from hitch ball.
4. Make sure that trailer does not move.

OPERATING INSTRUCTIONS

TRAILER SET-UP

Fitting the Trailer to the Watercraft (ADVANCED TEC iCatch)

The iCatch system must be adjusted specifically to the personal watercraft (PWC) hull type.

The iCatch system must be used along with the iCatch bow cup available at an authorized Sea-Doo personal watercraft (PWC) dealer.

WARNING

iCatch mechanism must be specifically adjusted to the personal watercraft (PWC) model and used exclusively with the iCatch bow cup. An incorrect adjustment may cause the iCatch mechanism to inadequately secure the personal watercraft (PWC) to the trailer.

There are three parameters to set on the iCatch system to fit the listed Sea-Doo personal watercraft (PWC) models:

- iCatch housing angle
- iCatch support height
- Bumper position.

Also, rollers contact and tongue weight must be adjusted if necessary. Tongue weight is adjusted by changing the iCatch support and/or axle position on the frame.

For proper adjustment guidelines, refer to the following tables and procedures.

Sea-Doo Models Reference Table

MODEL NAME	MODEL YEAR	SETTING TABLE
RXT™, RXT™-X™ with S³ hull™, GTX† Limited, Wake Pro 215	2010	A
RXT™ iS, GTX† iS™, GTX† Limited iS™	2009-2010	
RXT™, GTX†, GTX† Wake™, RXT™-X™ (except S³ hull™)	2002 through 2009	B
GTI™, GTI™ SE, Wake 155	2006 through 2010	C
RXP™	2004 through 2010	D
RXP™-X™	2008 through 2010	

Setting Tables

SETTING TABLE "A"		
iCatch housing angle setting		2
iCatch support height setting (lower bolt position)		1
Bumper position setting	Bumper holes	2
	Support holes	3
SETTING TABLE "B"		
iCatch housing angle setting		2
iCatch support height setting (lower bolt position)		3
Bumper position setting	Bumper holes	1
	Support holes	1
SETTING TABLE "C"		
iCatch housing angle setting		3
iCatch support height setting (lower bolt position)		3
Bumper position setting	Bumper holes	1
	Support holes	1
SETTING TABLE "D"		
iCatch housing angle setting		1
iCatch support height setting (lower bolt position)		3
Bumper position setting	Bumper holes	1
	Support holes	1

iCatch Housing Angle Setting

1. Loosen the iCatch housing upper bolt.
2. Remove the iCatch housing lower bolt.

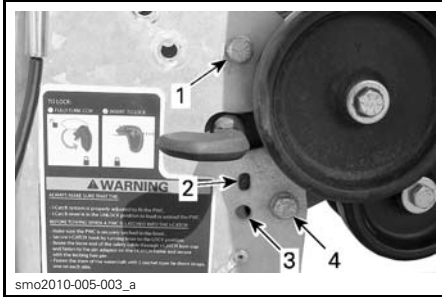

1. Upper bolt
2. Window
3. Lower front hole
4. Lower bolt (in rear hole)

3. Set angle:

- 3.1 Bring angle to the appropriate setting. The setting refers to the number visible in the window.
- 3.2 Lock iCatch housing in place by inserting the bolt through the appropriate lower hole.

NOTE: The front or rear lower hole will be aligned with the iCatch housing hole depending on the setting.

- 3.3 Tighten nuts to $27\text{ N}\cdot\text{m} \pm 3\text{ N}\cdot\text{m}$.

iCatch Support Height Setting

1. Remove iCatch support bolts and install in the appropriate holes.

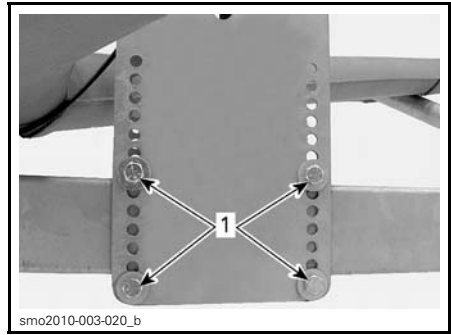

1. iCatch support bolts

NOTE: The iCatch support height setting refers to the lower bolt position. Insert upper bolt just above the tongue.

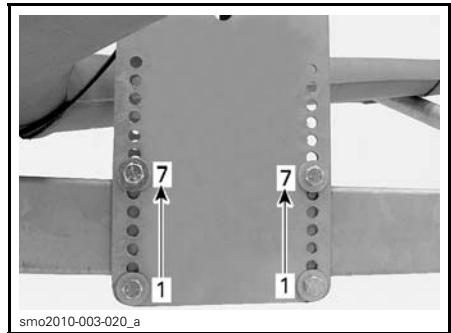

1. Position 1
7. Position 7

⚠ WARNING
There must be precisely 5 unused holes between upper and lower bolts.

2. Progressively tighten nuts in a criss-cross pattern until support is square with the trailer tongue. Do not tighten yet.
3. Adjust tongue weight, refer to *TONGUE WEIGHT* below.
4. Final tightening is $8\text{ N}\cdot\text{m} \pm 1\text{ N}\cdot\text{m}$.

Bumper Position Setting

The bumper position setting consists of a particular position of both the bumper holes and support holes.

1. Remove bumper retaining bolts.
2. Align appropriate support holes and bumper together.

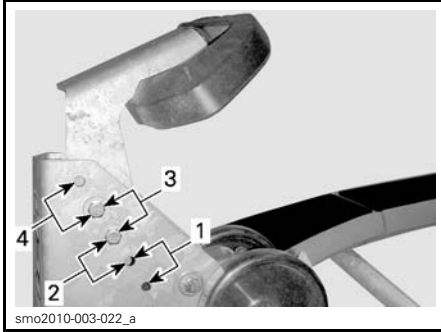

SUPPORT HOLES

1. Position 1
2. Position 2
3. Position 3
4. Position 4

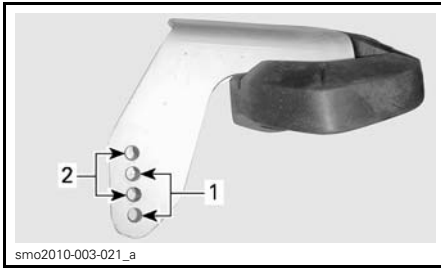

BUMPER HOLES

1. Position 1
2. Position 2
3. Install bolts loosely into proper positions.
4. **IMPORTANT:** Move bumper upwards then towards front and maintain it in this position.

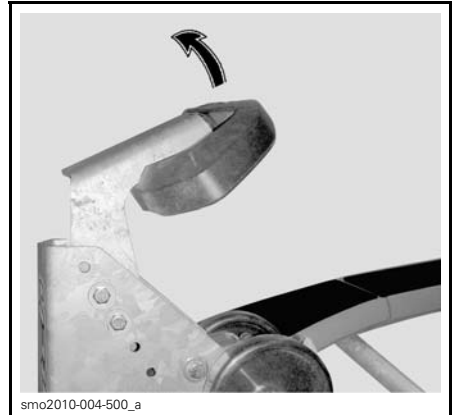

MOVE UPWARDS THEN FORWARD

5. Tighten bolts to $27 \text{ N}\cdot\text{m} \pm 3 \text{ N}\cdot\text{m}$.

NOTE: It is important to maintain bumper fully upwards and forward to eliminate any play in the assembly before tightening.

Axle Forward Positioning (RXP Models)

To suit the RXP models, the trailer axle must be moved forward from the factory position.

To set axle to the forward position, proceed as follows:

1. Loosen clamp bolts on both sides of the axle.

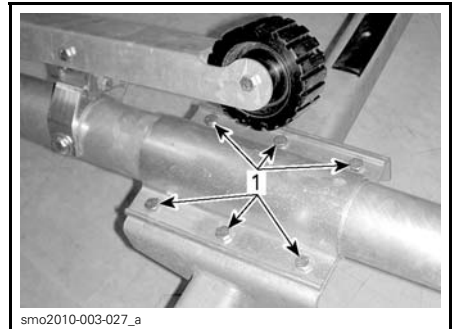

1. Axle clamp bolts

2. Remove both walk pad supports.



1. Walk pad support

3. Move axle forward until clamps lean on the front rollers supports.

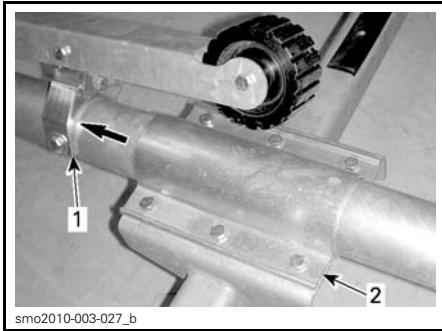

1. Front rollers support
2. Axle clamp

4. Install the RH walk pad support at left and the LH walk pad support at right. Tighten bolts to $11.5 \text{ N}\cdot\text{m} \pm 1.5 \text{ N}\cdot\text{m}$.
5. Tighten axle clamp bolts to $11.5 \text{ N}\cdot\text{m} \pm 1.5 \text{ N}\cdot\text{m}$.

Rollers

The rollers are preset to suit all Sea-Doo personal watercraft (PWC) hull designs, however, a universal rule applies: rollers must lean square against a plain area of the hull.

Make sure the rollers or bunks are well positioned.

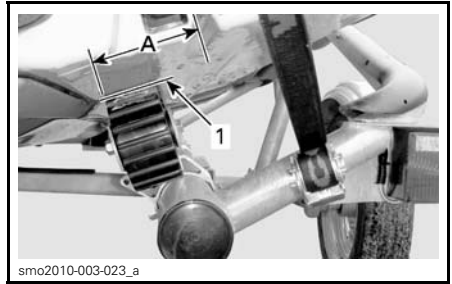

A. Plain area of hull
1. Roller square with hull

Tongue Weight

Move iCatch support towards front or rear of trailer in order to adjust tongue weight.

The tongue weight should be from 3 to 10% of the total trailer and PWC weight with tongue parallel to the ground.

A measurement is provided as an indication, however, the 3 to 10% rule prevails.

See following illustration and table for measurement instructions.

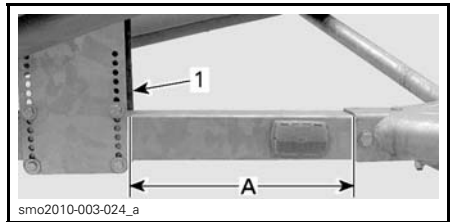

TONGUE MEASUREMENT

1. iCatch support
A. Distance to be measured as per table

TONGUE MEASUREMENT GUIDELINE		
MODEL NAME	MODEL YEAR	TONGUE DISTANCE
RXT™, RXT™-X™ with S ³ hull™, GTX ⁺ Limited, Wake Pro 215	2010	40.6 cm
RXT™ iS, GTX ⁺ iS™, GTX ⁺ Limited iS™	2009-2010	
RXT™, GTX ⁺ , GTX ⁺ Wake™, RXT™-X™ (except S ³ hull™)	2002 through 2009	33 cm
GTI™, GTI™ SE, Wake 155	2006 through 2010	28 cm
RXP™	2004 through 2010	30.5 cm
RXP™-X™	2008 through 2010	

To adjust, loosen the iCatch support bolts, move support to the desired position, then tighten nuts as follows:

1. Progressively tighten nuts in a crisscross pattern until support is square with the trailer tongue.
2. Tighten to $8\text{ N}\cdot\text{m} \pm 1\text{ N}\cdot\text{m}$.

Fitting the Trailer to the Watercraft (ADVANCED TEC)

Set tongue weight, bow stopper roller, and bunks as follows.

Tongue Weight

Move winch support towards front or rear of trailer in order to adjust tongue weight.

The tongue weight should be from 3 to 10% of the total trailer and PWC weight with tongue parallel to the ground.

To adjust, loosen the 4 nuts underneath the winch support u-bolts, move winch support to the desired position, then tighten nuts to $27\text{ N}\cdot\text{m} \pm 3\text{ N}\cdot\text{m}$.

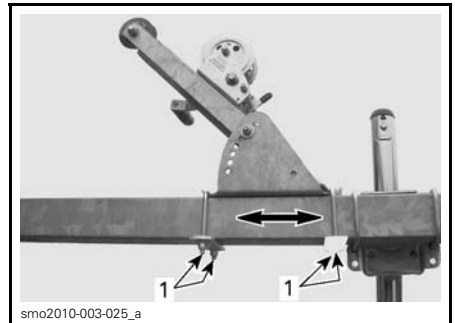

1. Winch support u-bolts nuts

Bow Stopper Roller

Set bow roller stopper so that it leans on the PWC bow between rubber bumper and bow eyelet.

To adjust:

1. Loosen the 2 nuts underneath the front winch support u-bolt.
2. Remove the winch arm adjustment bolt.
3. Set the bow roller stopper to the desired height, then lock it in position by inserting the bolt through the aligned winch support and winch arm holes.

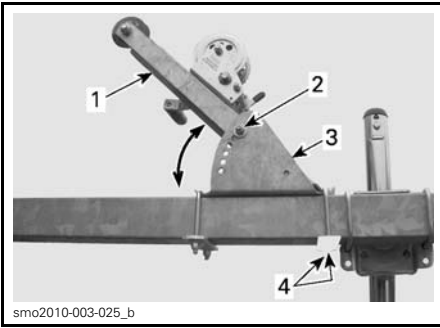

smo2010-003-025_b

1. Winch arm
 2. Winch arm adjustment bolt
 3. Winch support
 4. Front u-bolt nuts
4. Tighten u-bolt nuts to $27\text{ N}\cdot\text{m} \pm 3\text{ N}\cdot\text{m}$.
 5. Tighten winch arm adjustment bolt to $27\text{ N}\cdot\text{m} \pm 3\text{ N}\cdot\text{m}$.

Bunks

The wooden bunks are preset to suit all Sea-Doo personal watercraft (PWC) hull designs, however, a universal rule applies: bunks must lean square against a plain area of the hull.

Make sure the bunks are well positioned.

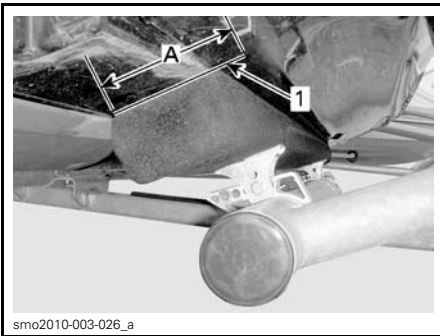

smo2010-003-026_a

- A. Plain area of hull
1. Bunk square with hull

BEFORE GETTING UNDERWAY

Attaching the Trailer to the Tow Vehicle

1. Make sure that the coupler and hitch ball are the same size.
2. Have someone guiding you and back the tow vehicle until the coupler is just above the hitch ball.

NOTE: Make sure that the coupler clears the hitch ball. Adjust trailer height as required.

3. Be sure the coupler-locking mechanism is released.
4. Lower trailer coupler over the hitch ball.

NOTE: Coupler will lock automatically.

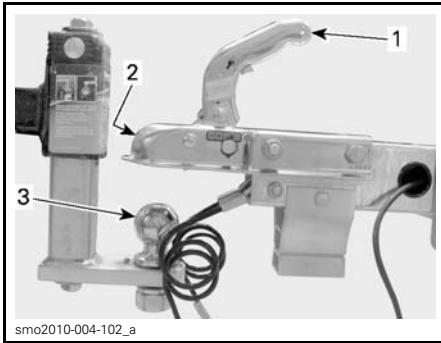

TYPICAL

1. Coupler-locking mechanism (released)
2. Coupler
3. Hitch ball

5. Check under the coupling to be certain that the ball clamp is below the ball and not riding on top of the ball.

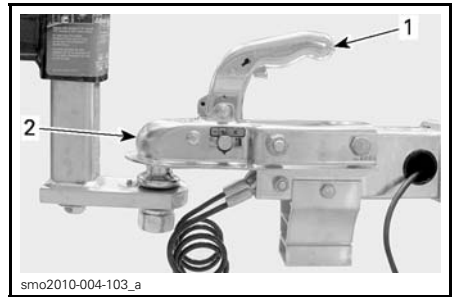

TYPICAL

1. Coupler-locking mechanism (locked)
2. Hitch ball in coupler

6. Ensure that coupler is in locked position.

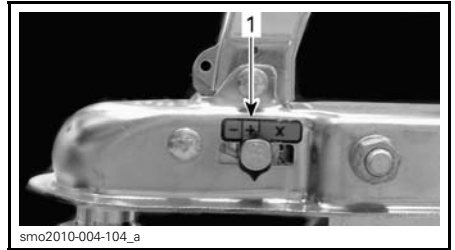

1. Locked position (green area)

7. Place locking pin through the coupler-locking mechanism.

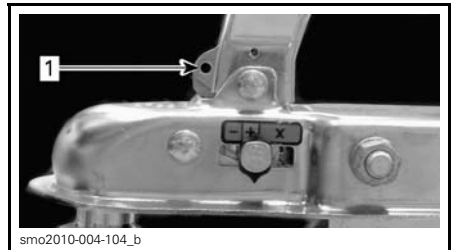

TYPICAL

1. Locking pin hole

8. Lift up on the trailer tongue. If it comes loose from the ball, unlock and start procedure again.

⚠ WARNING

If the coupler cannot be secured to hitch ball, do not tow the trailer. Refer to an authorized Sea-Doo personal watercraft (PWC) dealer to inspect the trailer as soon as possible.

NOTE: At this point the tow vehicle and the trailer should be level.

9. Attach the tongue safety cables or chains.

NOTE: Attach the left cable or chain to the bracket on the right side of hitch and the right cable or chain to the left bracket.

NOTICE To avoid damaging wiring harness, ensure the harness is not passed between the tongue safety cables or chains.

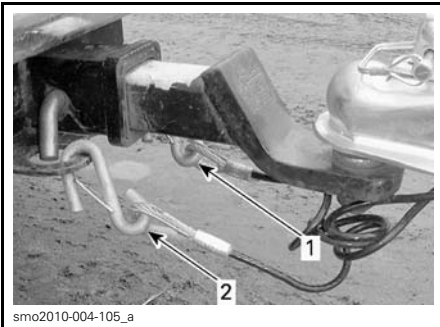

TYPICAL

1. LH tongue safety cable attached to the RH side of hitch
2. RH tongue safety cable attached to the LH side of hitch

10. Connect lights connector.

Pre-Use Inspection

WARNING

Perform a pre-use inspection before each use to detect potential problems during operation. The pre-use inspection can help you monitor wear and deterioration before they become a problem. Correct any problems that you discover to reduce the risk of a breakdown or crash. See an authorized Sea-Doo personal watercraft (PWC) dealer as necessary.

OPERATION	✓
Make sure the hitch ball size matches the coupler size.	
Check that the personal watercraft (PWC) is ready to be towed according to the PWC manufacturer's recommendations.	
Check that the jack is retracted.	
Check that wheel blocks are removed and properly secure to the tongue.	
Check tires condition and if they are properly inflated. Refer to <i>MAINTENANCE PROCEDURES</i> for details.	
Check tightness of wheel lug bolts.	
Check if load is within maximum load carrying capacity.	
Check if coupler is latched and locked.	
Check if tongue safety cables or chains are crisscrossed under tongue and attached to hitch.	
Check that taillights are properly secured to the trailer.	
Check lights operation.	
Clean all reflectors and lights lenses.	
Check if personal watercraft (PWC) is properly secured to the trailer at rear.	
Check that the iCatch system or winch is locked.	
Make sure the personal watercraft (PWC) is properly secured at front using the safety cable.	

TOWING THE TRAILER

Follow the tow vehicle's manufacturer instructions regarding trailer towing.

SEVERE INJURY OR DEATH can result if you do not follow these instructions:

When towing the trailer, pay particular attention to the following:

- Use a longer following distance from the vehicle in front of you.
- When towing a trailer, more time and distance is needed when passing or stopping.
- Reduce your speed and slow down more than usual before turning and avoid sharp turns.
- When cornering, achieve the turn on a larger radius. It takes more space to turn with a trailer.
- Always move slowly when backing up. Ask someone to guide you when possible. Practice in an open area at the first opportunity.
- If trailer starts to sway, do not hit the brakes or compensate using the steering wheel. Reduce speed and maintain a steady course.
- When going downhill, reduce speed before starting the descent. Do not brake continuously. Apply and release brakes alternately to prevent brakes from overheating.

Loss of control of the trailer or trailer/vehicle combination can result in serious injury or death. The most common causes of loss of control of the trailer are:

- Driving too fast for the conditions.
- Overloading the trailer or loading the trailer incorrectly.
- Trailer improperly coupled to the hitch.
- Inadequate towing hitch.
- Not maintaining proper tire pressure.
- Not keeping wheel lug bolts tight.

LAUNCHING THE WATERCRAFT

Launching the Watercraft (ADVANCED TEC iCatch)

NOTICE Taillights are not submersible, before launching or loading, always remove taillights.

1. Prepare the personal watercraft (PWC) for launching according to the PWC manufacturer's recommendations.
2. Remove tie-downs from stern and trailer eyelets.
3. Remove safety cable from bow cup.
4. Disconnect taillight connector as follows:
 - 4.1 Rotate connector counter-clockwise.
 - 4.2 Pull connector out of the mounting plate.

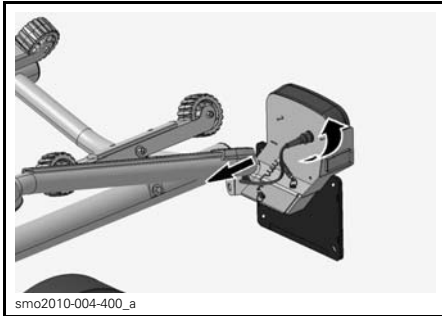

5. Unscrew both locking devices.

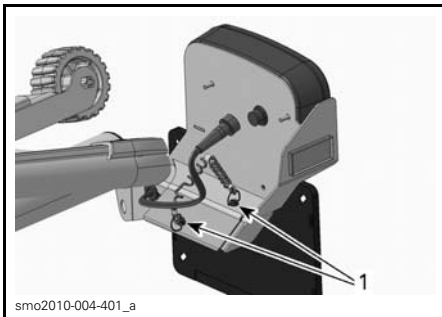

1. Locking devices

6. Remove taillight from trailer by pulling it upwards.

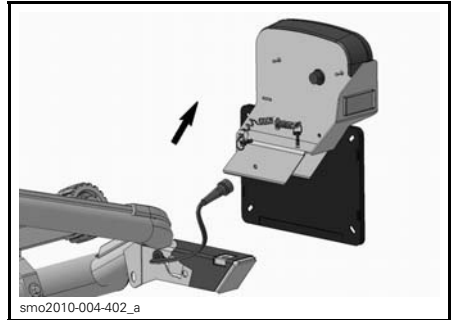

7. Carry out same steps for removing the other taillight.
8. Make sure the way is clear behind the trailer (in and out of water).

CAUTION The watercraft can easily travel 10 m on the water once launched from the trailer.

9. Have someone guiding you and back the vehicle until water level is within the water level decal upper and lower edges.



WATER LEVEL DECAL

NOTE: On very gentle slopes, water level may go over the decal zone, however, the PWC must not float above the rollers.

10. Unlock the iCatch mechanism by pulling lever out and turning clockwise.



Step 1: Pull lever out
Step 2: Turn clockwise

NOTE: Always make sure that the iCatch system is unlocked before attempting to unload the PWC.

11. Take place on the watercraft.
12. Put your personal flotation device (PFD) on and attach the safety lanyard to it.
13. Get watercraft ready for engine starting but do not start engine yet.
14. Pull the iCatch release handle up. Handle will stay up indicating that the iCatch is ready for further loading.



PULL HANDLE UP

15. Once the watercraft has rolled off the trailer, start engine.

NOTICE Rocks, sand or other debris will be sucked into the watercraft propulsion system if engine is operated using too much throttle in shallow water.

16. Moor the watercraft.
17. Drive the tow vehicle out of the ramp.
18. Install taillights on trailer.
19. Connect taillights connector.

Launching the Watercraft (ADVANCED TEC)

NOTICE Taillights are not submersible, before launching or loading, always remove taillights.

1. Prepare the personal watercraft (PWC) for launching according to the PWC manufacturer's recommendations.
2. Remove tie-downs from stern and trailer eyelets.
3. Disconnect taillight connector as follows:
 - 3.1 Rotate connector counterclockwise.
 - 3.2 Pull connector out of the mounting plate.

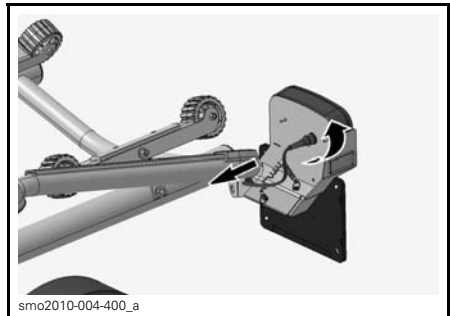

4. Unscrew both locking devices.

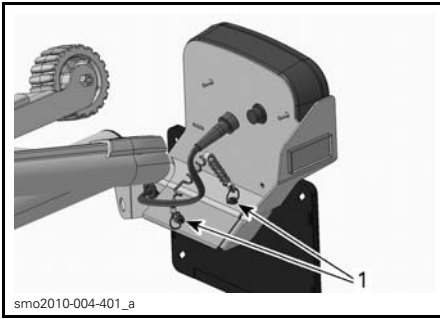

1. Locking devices

5. Remove taillight from trailer by pulling it upwards.

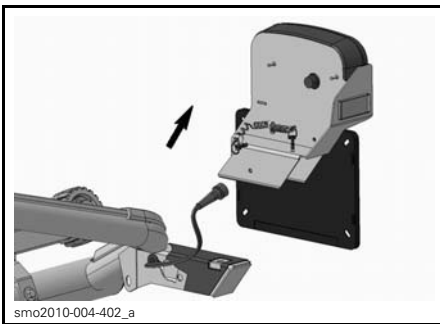

6. Carry out same steps for removing the other taillight.
7. Make sure the way is clear behind the trailer (in and out of water).
8. Attach ropes to the watercraft mooring cleats and prevent them from hanging.
9. Have someone guiding you and back the vehicle until trailer reaches the desired depth into water.

NOTE: The PWC must not float above the bunks.

10. Hold the winch handle firmly and set winch mechanism to "unwind".

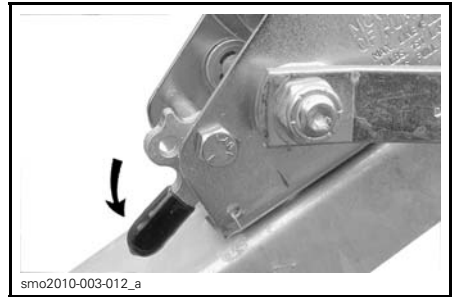

SET WINCH TO "UNWIND"

11. Unwind until watercraft slides off the trailer and floats. It may be necessary to push the watercraft a little.
12. Grab the ropes previously attached to the mooring cleats, then moor the watercraft.
13. Drive the tow vehicle out of the ramp.
14. Install taillights on trailer.
15. Connect taillights connector.

LOADING THE WATERCRAFT

Loading the Watercraft (ADVANCED TEC iCatch)

NOTICE Taillights are not submersible, before launching or loading, always remove taillights.

1. Disconnect taillights connector.
2. Remove taillights from trailer, refer to *LAUNCHING THE WATERCRAFT* in this subsection for the procedure.
3. Make sure the iCatch system is unlocked and the release handle is UP.



WATER LEVEL DECAL

NOTE: On very gentle slopes, water level may go over the decal zone, however, the PWC must not float above the rollers when watercraft contacts the iCatch mechanism.

5. Take place on the watercraft.
6. Put your personal flotation device (PFD) on and attach the safety lanyard to it.
7. Start engine and steer watercraft at idle speed to align it with the trailer rollers.



UNLOCKED (HORIZONTAL)



HANDLE UP

WARNING

Always make sure the iCatch system is unlocked before loading the watercraft.

4. Have someone guiding you and back the vehicle until water level is within the water level decal upper and lower edges.

WARNING

Make sure nobody stands on the walk pads when loading the watercraft.

8. At idle, make contact between the watercraft bow with the iCatch mechanism. It may be necessary to slightly depress throttle lever for this operation.

NOTICE Rocks, sand or other debris will be sucked into the watercraft propulsion system if engine is operated using too much throttle in shallow water.

NOTE: Make sure that the iCatch handle has returned in the closed position (DOWN).

WARNING

Make sure the watercraft is securely latched to the iCatch mechanism.

9. Lock the iCatch mechanism.



sмо2010-005-005_a

LOCK MECHANISM

10. Drive the tow vehicle out of the ramp.

11. Secure PWC bow to the trailer using the safety cable.

WARNING

Inspect safety cable before every use. Replace a damaged cable before trailering.

11.1 Pass the cable through the bow cup.

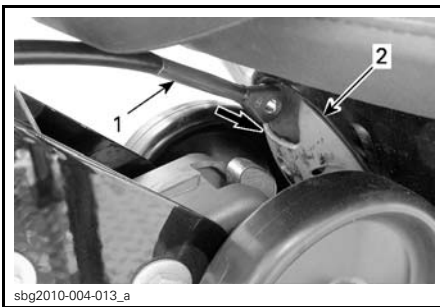

sbg2010-004-013_a

1. Safety cable
2. Bow cup

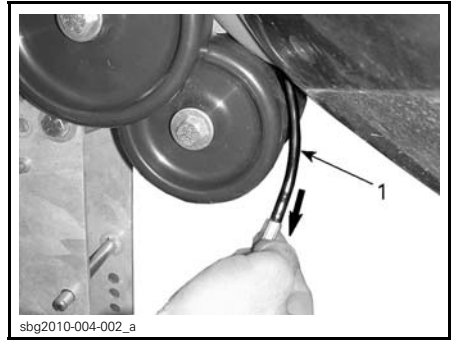

sbg2010-004-002_a

1. Safety cable

NOTE: Make sure that the safety cable passes between the lower iCatch mechanism wheels.

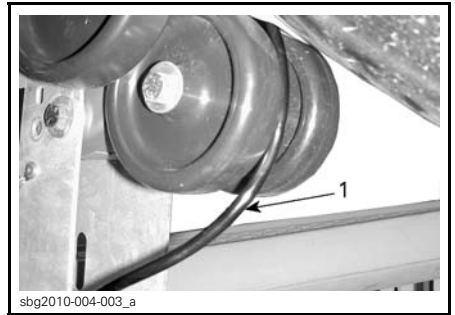

sbg2010-004-003_a

1. Safety cable

11.2 Attach the cable to the fastening pin.

11.3 Secure safety cable to the fastening pin using the hair-pin clip.

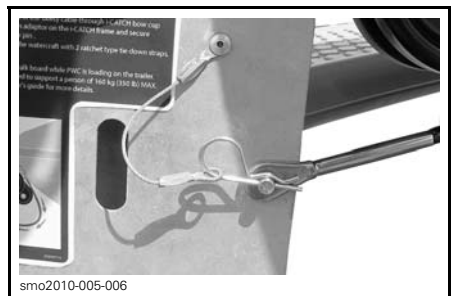

sмо2010-005-006

SAFETY CABLE SECURED

- On both sides, secure rear of PWC to the trailer using suitable tie-downs attached to the stern eyelets and trailer eyelets together.

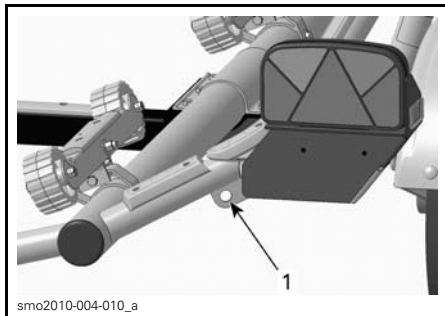

smo2010-004-010_a
RH REAR OF TRAILER
1. Trailer eyelet

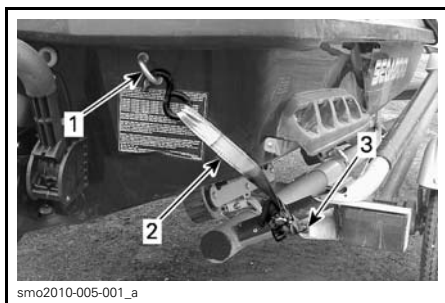

smo2010-005-001_a
1. PWC stern eyelet
2. Tie-down
3. Trailer eyelet

⚠ WARNING

Before towing, make sure:

- PWC is securely latched at front.
- iCatch mechanism is locked.
- PWC is secured to the trailer at rear using tie-downs.
- PWC is secured to the trailer at front using the safety cable.

- Install taillights on trailer.
- Connect taillights connector.

Loading the Watercraft (ADVANCED TEC)

NOTICE Taillights are not submersible, before launching or loading in, always remove taillights.

- Disconnect taillights connector.
- Remove taillights from trailer, refer to *LAUNCHING THE WATERCRAFT* in this subsection for the procedure.
- Have someone guiding you and back the vehicle until the trailer reaches the desired depth into water.

NOTE: Bunks should be immersed in water just enough for the watercraft to be dragged onto them without floating over them.

- Align the watercraft with the trailer bunks.
- Unwind the winch and attach the hook or strap to the watercraft's front bow eyelet.
- Set winch mechanism to "wind", then wind until watercraft bow reaches the trailer bow stop roller.

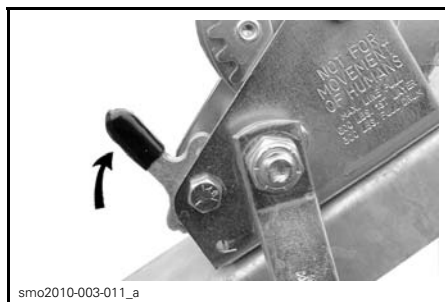

smo2010-003-011_a
SET WINCH TO "WIND"

- Drive the tow vehicle out of the ramp.
- Secure personal watercraft (PWC) on the trailer using suitable tie-downs attached to the stern eyelets and trailer eyelets together.

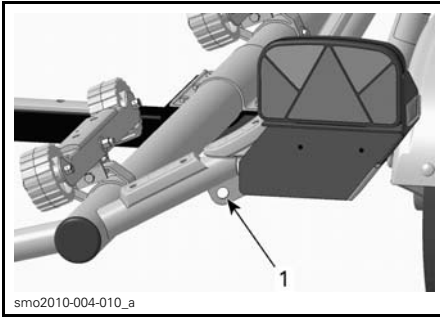

smo2010-004-010_a

RH REAR OF TRAILER

1. Trailer eyelet

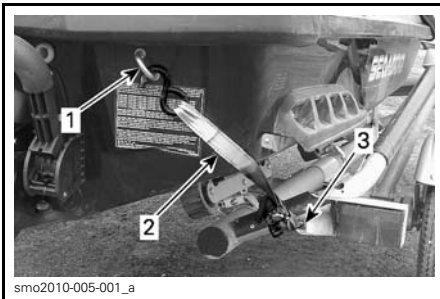

smo2010-005-001_a

TYPICAL

1. PWC stern eyelet
2. Tie-down
3. Trailer eyelet

9. Install taillights on trailer.
10. Connect taillights connector.

***This page is
intentionally blank***

TECHNICAL INFORMATION

TRAILER IDENTIFICATION NUMBER

The trailer is identified by a serial number. It may sometimes become necessary to locate this number for warranty purposes or to trace the trailer in the event of theft.



1. Serial number

TECHNICAL INFORMATION LABELS

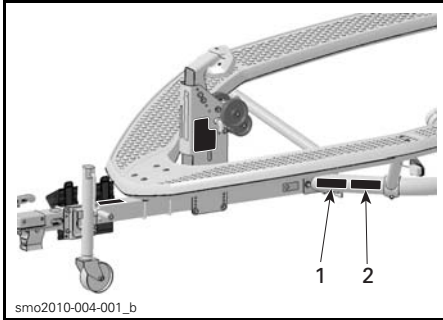

NOTICE

Taillights are not submersible.

Before each loading or launching, remove taillights :

- Unplug the wire connector.
- Loosen the knob by 2-3 turn.
- Slide out the taillight and put it on a safe place.

After each loading or launching

- Put back the taillight on the bracket.
- Tighten the knob.
- Plug the wire connector.

219903348

219903348
LABEL 3



TYPICAL

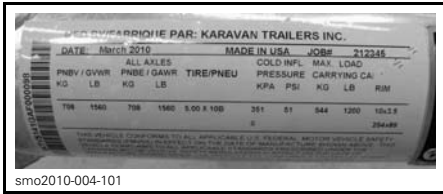

LABEL 1

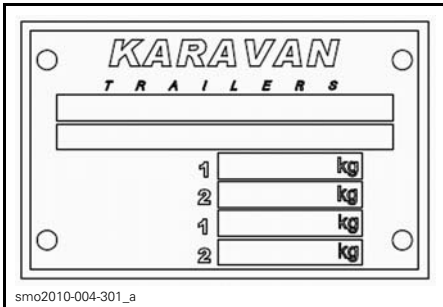

LABEL 2

SPECIFICATIONS

MODEL	ADVANCED TEC	ADVANCED TEC iCATCH
WEIGHT AND DIMENSIONS		
Overall length	4.1 m	
Overall width	1.8 m	
Width between fenders ⁽¹⁾	1.4 m	-
Width between walk pads ⁽¹⁾	-	1.3 m
Overall height (iCatch) ⁽³⁾	-	99 cm
Overall height (walk pad) ⁽²⁾	-	81 cm
Overall height (fender) ⁽²⁾	58 cm	-
Overall height (winch) ⁽³⁾	79 cm	-
Coupler	5 cm	
WEIGHT AND LOAD LIMITS		
Approximate dry weight	118 kg	163 kg
Carrying capacity	590 kg	544 kg
TIRES AND WHEELS		
Tire size	5.00 X 10 (in)	
Wheel size	3.5 x 10 (in)	
Cold pressure	351 kPa	
Lug bolts torque	90 N•m ± 10 N•m	
Minimum thread depth	1.6 mm	

(1) Maximum PWC width.

(2) Tongue on the ground.

(3) Hitch coupler 41 cm above the ground.

MAINTENANCE

MAINTENANCE SCHEDULE

Maintenance is very important for keeping your trailer in safe operating condition.

The maintenance schedule does not exempt the pre-use inspection.

NOTE: If trailer is used all year round, carry out both *STORAGE* and *PRE-SEASON* maintenance operations once a year.

At Storage

Carry out the following at trailer storage:

- Tighten loose fasteners and connections.
- Inflate tires to recommended pressure.
- Check coupler condition and lubricate.
- Lubricate jack.
- Apply DIELECTRIC GREASE (P/N 293 550 004) in all electric connectors and light bulb socket to prevent corrosion.
- ADVANCED TEC: Check winch and strap condition. Lubricate winch mechanism.
- If possible, park trailer in a protected area, garage, carport, etc.
- Raise trailer and place blocks under trailer frame to take most of the weight off the suspension and tires.

At Pre-Season

Carry out the following before using trailer after a storage period:

- Inspect wheels for damage.
- Check tightness of all fasteners.
- Check wheel bearing and seals.
- ADVANCED TEC iCatch: Have the iCatch mechanism, release cable and release handle condition checked by an authorized Sea-Doo dealer.
- Check wiring harness condition.
- Inspect safety cable.

MAINTENANCE PROCEDURES

This section includes instructions for basic maintenance procedures. If you have the necessary mechanical skills and the required tools, you can perform these procedures. If not, see your authorized Sea-Doo personal watercraft (PWC) dealer.

WARNING

Torque wrench tightening specifications must be strictly adhered to.

Locking devices, when removed (e.g.: locking tabs, elastic stop nuts, cotter pins, etc.), must be replaced.

Hoses, cables or locking ties removed during a procedure must be reinstalled as per factory standards.

Safety Cable

Safety Cable Inspection

Inspect cable for damage.

If cable or its liner are damaged, stop using the trailer and contact a Sea-Doo authorized dealer.

WARNING

Do not use the trailer if safety cable is damaged.

Coupler

Coupler Inspection and Lubrication

Check locking mechanism operation.

Check ball socket, ball clamp and lock mechanism for wear or damage.

Apply a thin coat of multipurpose grease to the inner surface of the ball socket.

Apply light oil to the pivot and sliding surface of the lock mechanism.

Tires

Tire Pressure

Check tires pressure. Tire pressure must be checked while the tire is cold.

NOTE: Do not check the tire pressure immediately after towing the trailer. Allow at least three hours for a tire to cool down, if the trailer has been towed for as much as 1.6 km.

TIRE PRESSURE	
COLD TIRE	351 kPa

Tire Inspection

Replace the tire before towing the trailer if the tire tread has less than 1.6 mm depth or if the built-in wear indicator bars are visible and flush with the remainder of the tire tread.

Always replace a tire with one of the same dimensions and load limit.

Inspect both sidewalls of each tire for any bubble, cut or bulge; and replace a damaged tire before towing the trailer.

WARNING

A bubble, cut or bulge in the sidewall can result in a tire blowout and loss of control.

Wheels

Wheel Inspection

Check wheel for cracks, bumps or other damages. Replace wheel as required.

Wheel Bearings and Seals

Wheel Bearing Inspection

Install a jack under the axle and raise until the tire gets off the ground.

Push and pull the wheel from the upper edge to feel the play and rotate wheel.

If any play is felt or if wheel does not turn smoothly, have the wheel bearing replaced.

Wheel Bearing Seal Inspection

A slight film of grease around the seal is normal. Have the seal replaced if an excessive leak or damage is noticed.

Lights

Light Bulb Replacement

Taillights Bulb Replacement

1. Remove the lens retaining screws.

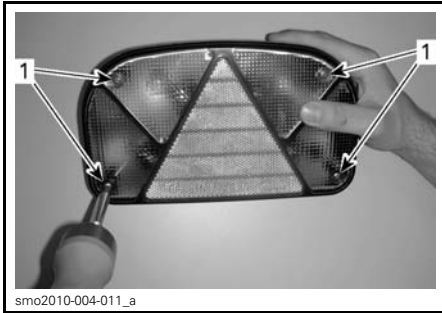

TAILLIGHT REMOVED FOR CLARITY PURPOSE

1. Lens retaining screws

2. Remove lens from housing.
3. Remove burnt light bulb as follows:
 - 3.1 Push the bulb in and turn counterclockwise.



TAILLIGHT REMOVED FOR CLARITY PURPOSE

1. Light bulbs

4. Install a new light bulb as follows:
 - 4.1 Index the bulb base with the socket.
 - 4.2 Push in, then turn clockwise to lock it.
5. Install lens then secure it using retaining screws.

NOTICE Do not overtighten retaining screws.

License Plate Bulb Replacement

1. Remove lens, refer to *TAILLIGHTS BULB REPLACEMENT*.
2. Push both tabs then pull burnt bulb.

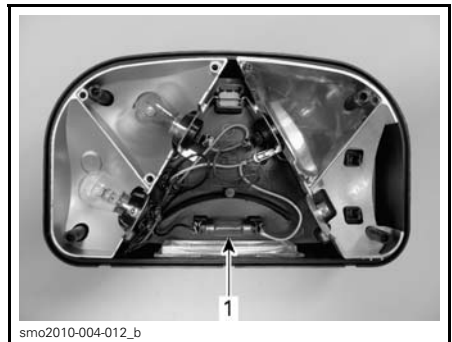

TAILLIGHT REMOVED FOR CLARITY PURPOSE

1. License plate bulb

3. Install a new bulb by pushing it in.

4. Install lens then secure it using retaining screws.

NOTICE Do not overtighten retaining screws.

Front Positioning Light Bulb Replacement

1. Remove the lens retaining screws.

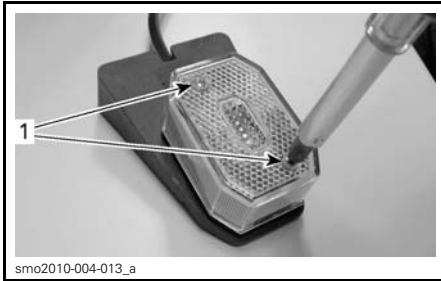

smo2010-004-013_a
POSITIONING LIGHT REMOVED FOR CLARITY PURPOSE

1. *Lens retaining screws*
2. Remove lens from housing.
3. Remove burnt light bulb by pulling it off its socket.



smo2010-004-014_a
POSITIONING LIGHT REMOVED FOR CLARITY PURPOSE

1. *Light bulbs*
4. Install a new light bulb by pushing it completely into its socket.
5. Install lens then secure it using retaining screws.

NOTICE Do not overtighten retaining screws.

Winch

Winch Inspection

Inspect gears, bushings and strap for wear or damage.

Winch Lubrication

Apply a thin coat of multipurpose grease to the gearing teeth and pivot points. Rotate handle to distribute grease evenly.

Lubricate ratchet pivot point with light oil.

Jack

Jack Lubrication

Clean grease fitting, then lubricate using multipurpose grease. Rotate handle to distribute grease evenly.

Lubricate handle pivot point and wheel axle with light oil. Wipe excess oil and rotate parts to distribute oil evenly.

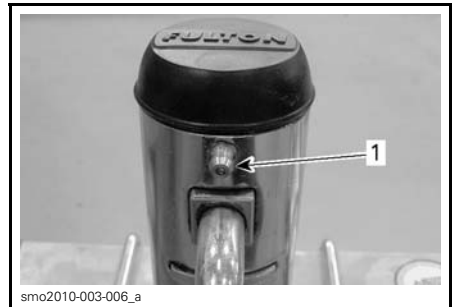

smo2010-003-006_a
 1. *Grease fitting*

Wooden Bunks (ADVANCED TEC)

Check wooden bunks carpet condition and wood hardness.

Rollers (ADVANCED TEC iCatch)

Check rollers for looseness wear, cracks or damage.

TRAILER CARE

Salt Water Use

If trailer is used in salt water, thoroughly rinse trailer daily with fresh water.

Trailer Cleaning

1. Rinse the trailer thoroughly with fresh water to remove loose dirt.
2. Using a soft, clean cloth, wash the trailer with water mixed with a mild detergent, such as soap specially formulated for motorcycles or automobiles.
3. While washing the trailer, check for grease or oil. An automotive grease remover can be used. Thoroughly follow the manufacturer's instructions.
4. Dry the trailer with a chamois or a soft towel.

 **CAUTION** Never use any kind of vinyl or plastic protector on the walk pads as they would get slippery.

WARRANTY

BRP LIMITED WARRANTY - USA AND CANADA: 2010 SEA-DOO® ADVANCED TEC™ PWC TRAILER

1) SCOPE OF THE LIMITED WARRANTY

Bombardier Recreational Products Inc. ("BRP")™* warrants its 2010 Sea-Doo Advanced Tec PWC trailer ("Trailer") sold by authorized Sea-Doo Dealers (as defined below) in the fifty United States and in Canada from defects in material or workmanship for the period and under the conditions described below. This limited warranty will become null and void if the Trailer has been altered or modified in such a way so as to adversely affect its operation, performance or durability, or has been altered or modified to change its intended use.

All genuine Trailer parts and accessories installed on the Trailer by an authorized Sea-Doo Dealer at the time of delivery of the Trailer will carry the same warranty as that of the Trailer.

2) LIMITATIONS OF LIABILITY

THIS WARRANTY IS EXPRESSLY GIVEN AND ACCEPTED IN LIEU OF ANY AND ALL OTHER WARRANTIES, EXPRESSED OR IMPLIED, INCLUDING WITHOUT LIMITATION ANY WARRANTY OF MERCHANTABILITY OR FITNESS FOR A PARTICULAR PURPOSE. TO THE EXTENT THAT THEY CANNOT BE DISCLAIMED, THE IMPLIED WARRANTIES ARE LIMITED IN DURATION TO THE LIFE OF THE EXPRESS WARRANTY. INCIDENTAL AND CONSEQUENTIAL DAMAGES ARE EXCLUDED FROM COVERAGE UNDER THIS WARRANTY. SOME STATES/PROVINCES DO NOT ALLOW FOR THE DISCLAIMERS, LIMITATIONS AND EXCLUSIONS IDENTIFIED ABOVE, AS A RESULT, THEY MAY NOT APPLY TO YOU. THIS WARRANTY GIVES YOU SPECIFIC RIGHTS, AND YOU MAY ALSO HAVE OTHER LEGAL RIGHTS WHICH MAY VARY FROM STATE TO STATE, OR PROVINCE TO PROVINCE.

Neither the distributor, any Sea-Doo Dealer nor any other person has been authorized to make any affirmation, representation or warranty regarding the Trailer, other than those contained in this limited warranty, and if made, shall not be enforceable against BRP. BRP reserves the right to modify this warranty at any time, being understood that such modification will not alter the warranty conditions applicable to the Trailer sold while this warranty is in effect.

3) EXCLUSIONS – ARE NOT WARRANTED

The following are not warranted under any circumstances:

- Replacement of routine maintenance items including the performance of adjustments.
- Normal wear and tear.
- Damages related to the appearance of the Trailer, including without limitation scratches, dents, fading, flaking, and peeling.
- Damage caused by failure to provide proper maintenance or storage, as described in the User's Guide.
- Damage resulting from removal of parts, improper repairs, improper service or improper maintenance, modifications, alterations that are outside of the original specifications of the Trailer, or damage resulting from repairs done by a person that is not an authorized servicing Sea-Doo Dealer.

- Damage resulting from the installation of parts with specifications that differ from the original Trailer parts, such as, without limitation, different tires or wheels.
- Damage resulting from abuse, abnormal use, or neglect.
- Damage resulting from accident, road hazards, submersion, fire, theft, vandalism or any act of God.
- Damage resulting from corrosion from road salts, environmental influences or treatment contrary to the User's Guide.
- Incidental or consequential damages, including without limitation towing, storage, telephone, rental, taxi, inconvenience, insurance coverage, loan payments, loss of time, loss of income.

4) WARRANTY COVERAGE PERIOD

This warranty will be in effect from the date of delivery to the first retail consumer or the date the Trailer is first put into use, whichever occurs first and for the following periods:

1. **TWELVE (12) CONSECUTIVE MONTHS** for private, recreational use, except that the frame is covered for **SIXTY (60) CONSECUTIVE MONTHS**;
2. **FOUR (4) CONSECUTIVE MONTHS** for commercial use, except that the frame is covered for **TWELVE (12) CONSECUTIVE MONTHS**.

A Trailer is used commercially when it is used in connection with any work or employment that generates income, during any part of the warranty period. A Trailer is also used commercially when, at any point during the warranty period, it is licensed for commercial use.

The repair or replacement of parts or the performance of service under this warranty does not extend the life of this warranty beyond its original expiration date.

The repair or replacement of parts or the performance of service under this warranty does not extend the life of this warranty beyond its original expiration date.

5) CONDITIONS TO HAVE WARRANTY COVERAGE

This warranty coverage is available **only** if **each** of the following conditions has been fulfilled:

- The Trailer must be purchased as new and unused by its first owner from a Sea-Doo dealer authorized to distribute Trailers in the country in which the sale occurred ("Sea-Doo Dealer").
- The BRP specified pre-delivery inspection process must be completed, documented and signed by the purchaser.
- The Trailer must have undergone proper warranty registration by an authorized Sea-Doo Dealer.
- The Trailer must be purchased in the country in which the purchaser resides.
- Routine maintenance must be performed as indicated in the User's Guide. BRP reserves the right to make warranty coverage contingent upon proof of proper maintenance.

BRP will not honor this limited warranty to any private use owner or commercial use owner if the preceding conditions have not been met. Such limitations are necessary in order to allow BRP to preserve both the safety of its products, and also that of its consumers and the general public.

6) WHAT TO DO TO OBTAIN WARRANTY COVERAGE

The customer must cease using the Sea-Doo personal watercraft upon the appearance of an anomaly. The customer must notify an authorized servicing BRP dealer within two (2) days of the appearance of a defect, and provide it with reasonable access to the product and reasonable opportunity to repair it. The customer must also present to the authorized BRP dealer, proof of purchase of the product and must sign the repair/work order prior to the start of the repair in order to validate the warranty repair. All parts replaced under this limited warranty become the property of BRP.

7) WHAT BRP WILL DO

BRP's obligations under this warranty are limited to, at its sole discretion, repairing parts found defective under normal use, maintenance and service, or replacing such parts with new genuine BRP parts without charge for parts and labor, at any authorized BRP dealer during the warranty coverage period under the conditions described herein. No claim of breach of warranty shall be the cause for cancellation or rescission of the sale of the Sea-Doo personal watercraft to the owner.

In the event that service is required outside of the country of original sale, the owner will bear responsibility for any additional charges due to local practices and conditions, such as, but not limited to, freight, insurance, taxes, license fees, import duties, and any and all other financial charges, including those levied by governments, states, territories and their respective agencies.

BRP reserves the right to improve or modify products from time to time without assuming any obligation to modify products previously manufactured.

8) TRANSFER

If the ownership of a product is transferred during the warranty coverage period, this warranty shall also be transferred and be valid for the remaining coverage period provided that BRP is notified of such transfer of ownership in the following way:

1. The former owner contacts BRP (at the phone number provided below) or an authorized BRP dealer and gives the coordinates of the new owner; or
2. BRP or an authorized BRP dealer receives a proof that the former owner agreed to the transfer of ownership, in addition to the coordinates of the new owner.

9) CONSUMER ASSISTANCE

In the event of a controversy or a dispute in connection with this BRP limited warranty, BRP suggests that you try to resolve the issue at the dealership level. We recommend discussing the issue with the authorized dealer's service manager or owner.

If the issue has not yet been resolved, please submit your complaint in writing or call the appropriate number below:

In Canada:

**BOMBARDIER RECREATIONAL
PRODUCTS INC.**
Sea-Doo
CUSTOMER ASSISTANCE CENTER
75 J.-A. Bombardier Street
Sherbrooke QC J1L 1W3
Tel: 819 566-3366

In USA:

BRP US INC.
Sea-Doo
CUSTOMER ASSISTANCE CENTER
7575 Bombardier Court
Wausau WI 54401
Tel: 715 848-4957

* In the USA, products are distributed and serviced by BRP US Inc.
© 2009 Bombardier Recreational Products Inc. All rights reserved.
™ Trademarks of Bombardier Recreational Products Inc. or its affiliates.
® Registered trademarks of Bombardier Recreational Products Inc.

BRP LIMITED WARRANTY - INTERNATIONAL: 2010 SEA-DOO® ADVANCED TEC™ PWC TRAILER

1) SCOPE OF THE LIMITED WARRANTY

Bombardier Recreational Products Inc. ("BRP")™* warrants its 2010 Sea-Doo Advanced Tec PWC trailer ("Trailer") sold by authorized Sea-Doo Dealers or Distributors (as defined below) outside of the fifty United States, Canada and member states of the European Economic Area (which is comprised of the states member of the European Union plus Norway, Iceland and Liechtenstein), will be free from defects in material or workmanship for the period and under the conditions described below. This limited warranty will become null and void if the Trailer has been altered or modified in such a way so as to adversely affect its operation, performance or durability, or has been altered or modified to change its intended use.

All genuine Trailer parts and accessories installed on the Trailer by an authorized Sea-Doo Dealer or Distributor at delivery of the Trailer will carry the same warranty as that of the Trailer.

2) LIMITATIONS OF LIABILITY

THIS WARRANTY IS EXPRESSLY GIVEN AND ACCEPTED IN LIEU OF ANY AND ALL OTHER WARRANTIES, EXPRESSED OR IMPLIED, INCLUDING WITHOUT LIMITATION ANY WARRANTY OF MERCHANTABILITY OR FITNESS FOR A PARTICULAR PURPOSE. TO THE EXTENT THAT THEY CANNOT BE DISCLAIMED, THE IMPLIED WARRANTIES ARE LIMITED IN DURATION TO THE LIFE OF THE EXPRESS WARRANTY. INCIDENTAL AND CONSEQUENTIAL DAMAGES ARE EXCLUDED FROM COVERAGE UNDER THIS WARRANTY. SOME COUNTRIES/STATES/PROVINCES DO NOT ALLOW FOR THE DISCLAIMERS, LIMITATIONS AND EXCLUSIONS IDENTIFIED ABOVE, AS A RESULT, THEY MAY NOT APPLY TO YOU. THIS WARRANTY GIVES YOU SPECIFIC RIGHTS, AND YOU MAY ALSO HAVE OTHER LEGAL RIGHTS WHICH MAY VARY DEPENDING ON COUNTRY OR REGION.

Neither the Distributor, or Dealer, nor any other person is authorized to make any affirmation, representation or warranty regarding the Trailer, other than those contained in this limited warranty, and if made, shall not be enforceable against BRP. BRP reserves the right to modify this warranty at any time, being understood that such modification will not alter the warranty conditions applicable to the Trailer sold while this warranty is in effect.

3) EXCLUSIONS – ARE NOT WARRANTED

The following are not warranted under any circumstances:

- Replacement of routine maintenance items including the performance of adjustments.
- Normal wear and tear.
- Damages related to the appearance of the Trailer, including without limitation scratches, dents, fading, flaking, and peeling.
- Damage from improper maintenance or storage, as described in the User's Guide.

- Damage resulting from removal of parts, improper repairs, improper service or improper maintenance, modifications, alterations that are outside of the original specifications of the Trailer, or damage resulting from repairs done by a person that is not an authorized servicing Sea-Doo Dealer or Distributor.
- Damage resulting from the installation of parts with specifications that differ from the original Trailer parts, such as, without limitation, different tires or wheels.
- Damage resulting from abuse, abnormal use, or neglect.
- Damage resulting from an accident, road hazards, submersion, fire, theft, vandalism, or any act of God.
- Damage resulting from corrosion from road salts, environmental influences or treatment contrary to the User's Guide.
- Incidental or consequential damages, including without limitation towing, storage, telephone, rental, taxi, inconvenience, insurance coverage, loan payments, loss of time, loss of income.

4) WARRANTY COVERAGE PERIOD

This warranty will be in effect from the date of delivery to the first retail consumer or the date the Trailer is first put into use, whichever occurs first and for the following periods:

1. **TWELVE (12) CONSECUTIVE MONTHS** for private, recreational use, except that the frame is covered for **SIXTY (60) CONSECUTIVE MONTHS**;
2. **FOUR (4) CONSECUTIVE MONTHS** for commercial use, except that the frame is covered for **TWELVE (12) CONSECUTIVE MONTHS**.

A Trailer is used commercially when it is used in connection with any work or employment that generates income, during any part of the warranty period. A Trailer is also used commercially when, at any point during the warranty period, it is licensed for commercial use.

The repair or replacement of parts or the performance of service under this warranty does not extend the life of this warranty beyond its original expiration date.

5) CONDITIONS TO HAVE WARRANTY COVERAGE

This warranty coverage is available **only** if **each** of the following conditions has been fulfilled:

- The Trailer must be purchased as new and unused by its first owner from a Sea-Doo dealer or distributor authorized to distribute Trailers in the country in which the sale occurred ("Sea-Doo Dealer or Distributor").
- The BRP specified pre-delivery inspection process must be completed, documented and signed by the purchaser.
- The Trailer must have been properly warranty registration by an authorized Sea-Doo Dealer or Distributor.
- The Trailer must be purchased in the country in which the purchaser resides.
- Routine maintenance must be performed as indicated in the User's Guide. BRP reserves the right to make warranty coverage contingent upon proof of proper maintenance.

BRP will not honour this limited warranty to any private use owner or commercial use owner if the preceding conditions have not been met. Such limitations are necessary in order to allow BRP to preserve both the safety of its products, and also that of its consumers and the general public.

6) WHAT TO DO TO OBTAIN WARRANTY COVERAGE

The customer must cease using the Trailer upon the appearance of an anomaly. The customer must notify a servicing Sea-Doo Dealer or Distributor within two (2) days of the appearance of a defect, and provide it with reasonable access to the product and reasonable opportunity to repair it. The customer must also present to the Dealer or Distributor a proof of purchase of the product and must sign the repair/work order prior to starting the repair in order to validate the warranty repair. All parts replaced under this limited warranty become the property of BRP.

7) WHAT BRP WILL DO

BRP's obligations under this warranty are limited to, at its sole discretion, repairing parts found defective under normal use, maintenance and service, or replacing such parts with new genuine Trailer parts without charge for parts and labor, at any authorized Sea-Doo Dealer or Distributor during the warranty coverage period. BRP's responsibility is limited to making the required repairs or replacements of parts. No claim of breach of warranty shall be cause for cancellation or rescission of the sale of the Trailer to the owner.

In the event that service is required outside of the country of original sale, the owner will bear responsibility for any additional charges due to local practices and conditions, such as, but not limited to, freight, insurance, taxes, license fees, import duties, and any and all other financial charges, including those levied by governments, states, territories and their respective agencies.

BRP reserves the right to improve or modify products from time to time without assuming any obligation to modify any products previously manufactured.

8) TRANSFER

If the ownership of a Trailer is transferred during the warranty coverage period, this warranty shall also be transferred and be valid for the remaining coverage period provided that BRP is notified of such transfer of ownership in the following way:

1. The former owner contacts BRP or, an authorized Sea-Doo Dealer or Distributor and gives the coordinates of the new owner; or
2. BRP or an authorized Sea-Doo Dealer or Distributor receives a proof that the former owner agreed to the transfer of ownership, in addition to the coordinates of the new owner.

9) CONSUMER ASSISTANCE

1. In the event of a controversy or a dispute in connection with this limited warranty, BRP suggests that you try to resolve the issue at the dealer level. We recommend discussing the issue with the authorised dealer's service manager or owner.
2. If further assistance is required, the distributor's service department should be contacted in order to resolve the matter.
3. If the matter still remains unresolved then contact BRP by writing to us at the address listed below.

For countries within Europe, Middle East, Africa, Russia & CIS, please contact our European office:

BRP EUROPE N.V.

Consumer Assistance Center
Skaldenstraat 125
9042 Gent
Belgium
Tel: +32-9-218-26-00

For Scandinavian countries, please contact our Finland office:

BRP FINLAND OY

Service Department
Isoaavantie 7
FIN-96320 Rovaniemi
Finland
Tel: +358 16 3208 111

For all other countries, please contact your local distributor or one of our North America offices:

Bombardier Recreational Products Inc.

Consumer Assistance Center
75 J.-A. Bombardier Street
Sherbrooke QC
Canada J1L 1W3
Tel.: +1 819 566-3366

You will find your distributor's coordinates on www.brp.com.

* For the territory covered by this limited warranty, products are distributed and serviced by Bombardier Recreational Products Inc. or its affiliates.

© 2009 Bombardier Recreational Products Inc. All rights reserved.

® Registered trademarks of Bombardier Recreational Products Inc.

BRP LIMITED WARRANTY FOR THE EUROPEAN ECONOMIC AREA: 2010 SEA-DOO® ADVANCED TEC™ PWC TRAILER

1) SCOPE OF THE LIMITED WARRANTY

Bombardier Recreational Product Inc. ("BRP")* warrants its 2010 Sea-Doo Advanced Tec PWC trailer ("Trailer") sold by authorized Sea-Doo Dealers or Distributors in the states that are members of the European Economic Area ("EEA") (which is comprised of the member states of the European Union plus Norway, Iceland and Liechtenstein) from defects in material or workmanship for the period and under the conditions described below.

This limited warranty will become null and void if the Trailer has been altered or modified in such a way so as to adversely affect its operation, performance or durability, or has been altered or modified to change its intended use.

All genuine Trailer parts and accessories installed on the Trailer by an authorized Sea-Doo Dealer or Distributor at delivery of the Trailer will carry the same warranty as that of the Trailer.

2) LIMITATIONS OF LIABILITY

THIS WARRANTY IS EXPRESSLY GIVEN AND ACCEPTED IN LIEU OF ANY AND ALL OTHER WARRANTIES, EXPRESSED OR IMPLIED, INCLUDING WITHOUT LIMITATION ANY WARRANTY OF MERCHANTABILITY OR FITNESS FOR A PARTICULAR PURPOSE. TO THE EXTENT THAT THEY CANNOT BE DISCLAIMED, THE IMPLIED WARRANTIES ARE LIMITED IN DURATION TO THE LIFE OF THE EXPRESS WARRANTIES. INCIDENTAL AND CONSEQUENTIAL DAMAGES ARE EXCLUDED FROM COVERAGE UNDER THIS WARRANTY. SOME JURISDICTIONS DO NOT ALLOW FOR THE DISCLAIMERS, LIMITATIONS AND EXCLUSIONS IDENTIFIED ABOVE, AS A RESULT, THEY MAY NOT APPLY TO YOU. THIS WARRANTY GIVES YOU SPECIFIC RIGHTS, AND YOU MAY ALSO HAVE OTHER LEGAL RIGHTS WHICH MAY VARY FROM COUNTRY TO COUNTRY.

Neither the Distributor, or Dealer, nor any other person is authorized to make any affirmation, representation or warranty regarding the Trailer, other than those contained in this limited warranty, and if made, shall not be enforceable against BRP.

BRP reserves the right to modify this warranty at any time, being understood that such modification will not alter the warranty conditions applicable to the Trailer sold while this warranty is in effect.

3) EXCLUSIONS – ARE NOT WARRANTED

The following are not warranted under any circumstances:

- Replacement of routine maintenance items including the performance of adjustments.
- Normal wear and tear.
- Damages related to the appearance of the Trailer, including without limitation scratches, dents, fading, flaking, and peeling.
- Damage from improper maintenance or storage, as described in the User's Guide.

- Damage resulting from removal of parts, improper repairs, improper service or improper maintenance, modifications, alterations that are outside of the original specifications of the Trailer, or damage resulting from repairs done by a person that is not an authorized servicing Sea-Doo Dealer or Distributor.
- Damage resulting from the installation of parts with specifications that differ from the original Trailer parts, such as, without limitation, different tires or wheels.
- Damage resulting from abuse, abnormal use, or neglect.
- Damage resulting from an accident, road hazards, submersion, fire, theft, vandalism, or any act of God.
- Damage resulting from corrosion from road salts, environmental influences or treatment contrary to the User's Guide.
- Incidental or consequential damages, including without limitation towing, storage, telephone, rental, taxi, inconvenience, insurance coverage, loan payments, loss of time, loss of income.

4) WARRANTY COVERAGE PERIOD

This warranty will be in effect from (1) the date of delivery to the first retail consumer or (2) the date the product is first put into use, whichever occurs first and for a period of:

1. **TWENTY-FOUR (24) CONSECUTIVE MONTHS** for private use, except that the frame is covered for **SIXTY (60) CONSECUTIVE MONTHS**;
2. **FOUR (4) CONSECUTIVE MONTHS** for commercial use, except that the frame is covered for **TWELVE (12) CONSECUTIVE MONTHS**.

A Trailer is used commercially when it is used in connection with any work or employment that generates income, during any part of the warranty period. A Trailer is also used commercially when, at any point during the warranty period, it is licensed for commercial use.

The repair or replacement of parts or the performance of service under this warranty does not extend the life of this warranty beyond its original expiration date.

Note that the duration and any other modalities of the warranty coverage are subject to the national or local legislation applicable in your country.

5) CONDITIONS TO HAVE WARRANTY COVERAGE

This warranty coverage is available **only** if **each** of the following conditions has been fulfilled:

- The Trailer must be purchased as new and unused by its first owner from a Sea-Doo dealer or distributor authorized to distribute Trailers in the country in which the sale occurred ("Sea-Doo Dealer or Distributor").
- The BRP specified pre-delivery inspection process must be completed, documented and signed by the purchaser.
- The Trailer must have been properly warranty registration by an authorized Sea-Doo Dealer or Distributor.
- The Trailer must be purchased in the country in which the purchaser resides.
- Routine maintenance must be performed as indicated in the User's Guide. BRP reserves the right to make warranty coverage contingent upon proof of proper maintenance.

BRP will not honour this limited warranty to any private use owner or commercial use owner if the preceding conditions have not been met. Such limitations are necessary in order to allow BRP to preserve both the safety of its products, and also that of its consumers and the general public.

6) WHAT TO DO TO OBTAIN WARRANTY COVERAGE

The customer must cease using the Trailer upon the appearance of an anomaly. The customer must notify a servicing Sea-Doo Dealer or Distributor within two (2) months of the appearance of a defect, and provide it with reasonable access to the product and reasonable opportunity to repair it. The customer must also present to the Dealer or Distributor a proof of purchase of the product and must sign the repair/work order prior to starting the repair in order to validate the warranty repair. All parts replaced under this limited warranty become the property of BRP.

Note that the notification period is subject to the applicable national or local legislation in your country.

7) WHAT BRP WILL DO

BRP's obligations under this warranty are limited to, at its sole discretion, repairing parts found defective under normal use, maintenance and service, or replacing such parts with new genuine Trailer parts without charge for parts and labor, at any authorized Sea-Doo Dealer or Distributor during the warranty coverage period. BRP's responsibility is limited to making the required repairs or replacements of parts. No claim of breach of warranty shall be cause for cancellation or rescission of the sale of the Trailer to the owner.

In the event that service is required outside of the EEA, the owner will bear responsibility for any additional charges due to local practices and conditions, such as, but not limited to, freight, insurance, taxes, license fees, import duties, and any and all other financial charges, including those levied by governments, states, territories and their respective agencies.

BRP reserves the right to improve or modify products from time to time without assuming any obligation to modify any products previously manufactured.

8) TRANSFER

If the ownership of a Trailer is transferred during the warranty coverage period, this warranty shall also be transferred and be valid for the remaining coverage period provided that BRP is notified of such transfer of ownership in the following way:

1. The former owner contacts BRP or, an authorized Sea-Doo Dealer or Distributor and gives the coordinates of the new owner; or
2. BRP or an authorized Sea-Doo Dealer or Distributor receives a proof that the former owner agreed to the transfer of ownership, in addition to the coordinates of the new owner.

9) CONSUMER ASSISTANCE

1. In the event of a controversy or a dispute in connection with this limited warranty, BRP suggests that you try to resolve the issue at the dealer level. We recommend discussing the issue with the authorised dealer's service manager or owner. You will find your Sea-Doo Dealer or Distributor coordinates on our website at www.brp.com.
2. If further assistance is required, the distributor's service department should be contacted in order to resolve the matter.
3. If the matter still remains unresolved then contact BRP by writing to us at the address listed below.

For countries within Europe, Middle East, Africa, Russia & CIS, please contact our European office:

BRP EUROPE N.V.

Customer Assistance Center
Skaldenstraat 125
9042 Gent
Belgium
Tel: +32-9-218-26-00

For Scandinavian countries, please contact our Finland office:

BRP FINLAND OY

Service Department
Isoaavantie 7
FIN-96320 Rovaniemi
Finland
Tel: +358 16 3208 111

For all other countries, please contact your local Can-Am ATV Distributor/Dealer (visit our website at www.brp.com for contact information), or contact our North America office at:

Bombardier Recreational Products Inc.

Customer Assistance Center
75 J.-A. Bombardier Street
Sherbrooke QC
Canada J1L 1W3
Tel.: +1 819 566-3366

* For the territory covered by this limited warranty, products are distributed and serviced by Bombardier Recreational Products Inc. or its affiliates.

© 2010 Bombardier Recreational Products Inc. All rights reserved.

™ Trademark of Bombardier Recreational Products Inc. or its affiliates.

ADDITIONAL TERMS AND CONDITIONS FOR FRANCE ONLY

The following terms and conditions are applicable to products sold in France only:

The seller shall deliver goods that are complying with the contract and shall be responsible for defects existing upon delivery. The seller shall also be responsible for defects resulting from packaging, assembling instructions or the installation when it is its responsibility per the contract or if accomplished under its responsibility. To be compliant with the contract, the good shall:

1. Be fit for normal use for goods similar thereto and, if applicable:
 - Correspond to the description provided by the seller and have the qualities presented to the buyer through sample or model;
 - Have the qualities that a buyer may legitimately expect considering the public declarations of the seller, the manufacturer of its representative, including in advertising or labeling; or
2. Have the characteristics mutually agreed upon as between the parties or be fit for the specific use intended by the buyer and brought to the attention of the seller and which accepted.

The action for failure to comply is prescribed after two years after delivery of the goods. The seller is responsible for the warranty for hidden defects of the good sold if such hidden defects are rendering the good unfit for the intended use, or if they diminish its use in such a way that the buyer would not have acquired the good or would have given a lesser price, had he known. The action for such hidden defects shall be taken by the buyer within 2 years of the discovery of the defect.

CUSTOMER INFORMATION

PRIVACY INFORMATION

BRP wishes to inform you that your coordinates will be used for safety and warranty related purposes. Furthermore, BRP and its affiliates may use its customer list to distribute marketing and promotional information about BRP and related products.

To exercise your right to consult or correct your data, or to be removed from the addressee-list for direct marketing, please contact BRP.

By E-mail: privacyofficer@brp.com

By mail: BRP
Senior Legal Counsel-Privacy Officer
726 St-Joseph
Valcourt Quebec
Canada,
J0E 2L0

CHANGE OF ADDRESS/OWNERSHIP

If your address has changed or if you are the new owner of the boat, be sure to notify BRP by either:

- Mailing one of the following card below;
- **North America only:** calling at 715 848-4957 (USA) or 819 566-3366 (Canada);
- Contacting an authorized BRP distributor/dealer.

In case of change of ownership, please join a proof that the former owner agreed to the transfer.

Notifying BRP, even after the expiration of the limited warranty, is very important as it enables BRP to reach the boat owner if necessary, like when safety recalls are initiated. It is the owner's responsibility to notify BRP.

STOLEN UNITS: In the event that your boat is stolen, you should notify your area's distributor warranty department of such. We will ask you to provide your name, address, phone number, Hull Identification Number and date it was stolen.

In North America

BOMBARDIER RECREATIONAL PRODUCTS INC.

Warranty Department
75 J.-A. Bombardier Street
Sherbrooke QC J1L 1W3
Canada

Other Areas in the World except Scandinavian Countries

BRP EUROPEAN DISTRIBUTION

Warranty Department
Chemin de Messidor 5-7
1006 Lausanne
Switzerland

Scandinavian Countries

BRP FINLAND OY

Service Department
Isoaavantie 7
FIN-96320 Rovaniemi
Tel.: +358 16 3208 111

***This page is
intentionally blank***

CHANGE OF ADDRESS CHANGE OF OWNERSHIP 

VEHICLE IDENTIFICATION NUMBER

Model Number

Vehicle Identification Number (V.I.N.)

OLD ADDRESS
OR PREVIOUS OWNER:

NAME

NO.

STREET

APT

CITY

STATE/PROVINCE

ZIP/POSTAL CODE

COUNTRY

TELEPHONE

NEW ADDRESS
OR NEW OWNER:

NAME

NO.

STREET

APT

CITY

STATE/PROVINCE

ZIP/POSTAL CODE

COUNTRY

TELEPHONE

E-MAIL ADDRESS

CHANGE OF ADDRESS CHANGE OF OWNERSHIP 

VEHICLE IDENTIFICATION NUMBER

Model Number

Vehicle Identification Number (V.I.N.)

OLD ADDRESS
OR PREVIOUS OWNER:

NAME

NO.

STREET

APT

CITY

STATE/PROVINCE

ZIP/POSTAL CODE

COUNTRY

TELEPHONE

NEW ADDRESS
OR NEW OWNER:

NAME

NO.

STREET

APT

CITY

STATE/PROVINCE

ZIP/POSTAL CODE

COUNTRY

TELEPHONE

E-MAIL ADDRESS

V00A2F_en2

219 000 747

CA

USER'S GUIDE, AVANCED TEC PWC TRAILER CE / ENGLISH
GUIDE DE L'UTILISATEUR, REMORQUE MOTOMARINE AVANCED TEC CE / ANGLAIS

FAIT AU / MADE IN CANADA

U/M:P.C.

®™ AND THE BRP LOGO ARE TRADEMARKS OF BOMBARDIER RECREATIONAL PRODUCTS INC. OR ITS AFFILIATES.
©2010 BOMBARDIER RECREATIONAL PRODUCTS INC. ALL RIGHTS RESERVED. PRINTED IN CANADA.

CE