



SEA-DOO® 2003

Operator's **XP DI**
Guide
Supplement

This supplement must be used in conjunction with the Sea-Doo 2003 Operator's Guide (P/N 219 000 290)

 **WARNING**

Read this guide thoroughly.
It contains important safety information.

®™ TRADEMARKS OF BOMBARDIER INC. OR ITS SUBSIDIARIES.
©2003 BOMBARDIER INC. ALL RIGHTS RESERVED
PRINTED IN CANADA



2 1 9 0 0 0 2 9 4

SAFETY WARNING

Disregarding any of the safety precautions and instructions contained in this *Operator's Guide*, the *Safety Handbook*, the *Safety Videocassette* and on the on-product warning labels could cause injury, including the possibility of death. The operator has the responsibility to inform passenger(s) of safety precautions.

This *Operator's Guide*, the *Safety Handbook* and *Safety Videocassette* should remain with the craft at the time of resale.

BOMBARDIER
RECREATIONAL PRODUCTS



DECLARATION  OF CONFORMITY

2003 PWC Electro Magnetic Compatibility (EMC) Compliance with 93/68 EC Directive.

The 2003 Sea-Doo Personal Watercraft do comply with the above mentioned directive and with 89/336 EC directive in order to match the current European requirements on Personal Watercraft (PWC).

Knight's Spray-Nine[†] is a trademark of Korkay System Ltd
GTX[†] is a trademark of Castrol Ltd. Used under license

The following trademarks are the property of Bombardier Inc. or its subsidiaries:

SEA-DOO®

BOMBARDIER-ROTAX®

BOMBARDIER LUBE®

BOMBARDIER Formula XP-S II Synthetic Injection Oil

Sea-Doo LK™

Rotax®

NOTE

Dear 2003 XP DI watercraft owner. Use the information pertaining to the RX DI model in the *2003 Operator's Guide* (P/N 219 000 290) and then use this supplement to complete the specific information that applies to your XP DI model.

TABLE OF CONTENTS

LOCATION OF THE IMPORTANT LABELS	3
LOCATION OF CONTROLS, COMPONENTS AND INSTRUMENTS .	6
FUNCTIONS OF CONTROLS, COMPONENTS AND INSTRUMENTS	8
15) Oil Injection Reservoir Cap.....	8
16) Front Storage Compartment Cover	8
26) Mooring Cleats	9
37) Fuses	9
38) Battery	9
41) Storage Compartment/Engine Cover Latches	9
42) Rear Access Cover	9
43) Automatic Bilge Pump.....	9
OPERATING INSTRUCTIONS	10
SPECIAL PROCEDURES.....	12
Towing the Watercraft in Water	12
MAINTENANCE	13
Lubrication	13
Periodic Inspection Chart.....	13
Fuses	14
TRAILERING, STORAGE AND PRE-SEASON PREPARATION.....	16
Storage	16
SPECIFICATIONS.....	21

LOCATION OF THE IMPORTANT LABELS

XP DI Models



F08L1UL

TYPICAL

Label 1

F08A04L

To reduce the risk of SEVERE INJURY or DEATH:
WEAR A PERSONAL FLOTATION DEVICE (PFD): All riders wear a Coast Guard approved PFD that is suitable for personal watercraft (PWC) use and is on the engine off or kept in the water until you exit the PWC. PFDs are on the engine off or kept in the water until you exit the PWC. PFDs are on the engine off or kept in the water until you exit the PWC. PFDs are on the engine off or kept in the water until you exit the PWC.



WEAR PROTECTIVE CLOTHING: Severe internal injuries can occur if riders exit the PWC into lower body openings of males or females. All riders should wear protective clothing (shorts, pants, and shoes) that provides equivalent protection (see Operator's Guide). Footwear, gloves, and goggles/glasses are recommended.

KNOW BOATING LAWS: Bombardier, Inc. recommends a minimum operator age of 16 years. Know the operator age and training requirements for your province/state. A PWC safety course is recommended and may be required in your province/state.

⚠ WARNING

ATTACH ENGINE SHUTOFF CORD (LANYARD) to PFD and keep it free from the PWC so that engine stops if operator falls off. After riding, remove cord from PWC to avoid unauthorized use by children or others.

RIDE WITHIN YOUR LIMITS AND AVOID AGGRESSIVE MANEUVERS to reduce the risk of loss of control, ejection, neck or wrist injuries, and broken bones. Do not pump brakes or waves.

DO NOT APPLY THROTTLE WHEN ANYONE IS AT REAR OF PWC to turn.

NEVER RIDE AFTER CONSUMING ALCOHOL.

KEEP ENGINE SHUTOFF CORD (LANYARD) FROM INTRUSIVE OBJECTS such as long hair, jewelry, loose clothing, or loose items in moving parts. Loose clothing or jewelry can become entangled in moving parts.

READ AND FOLLOW OPERATOR'S GUIDE.

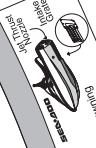

Operator's Guide

Operator's Guide

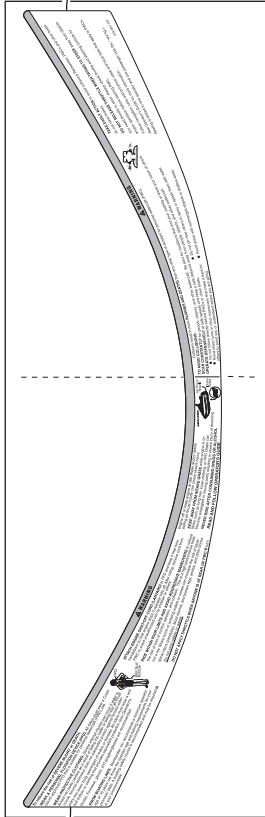

TO AVOID COLLISIONS:
SCAN CONSTANTLY for people, objects, and other watercraft. Be alert for conditions that limit your visibility or block your vision of others.

OPERATE DEFENSIVELY at all times and keep a safe distance away from people, objects, and other watercraft.

- Do not follow directly behind PWCs or other boats.
- Avoid sharp turns or other maneuvers that make it hard for others to avoid you or understand where you are going.
- Do not go near others to spray or splash them with water.
- Avoid areas with submerged objects or shallow water.

⚠ WARNING

Collisions result in more INJURIES AND DEATHS than any other type of accident for personal watercraft (PWC).

Collisions result in more INJURIES AND DEATHS than any other type of accident for personal watercraft (PWC).



TAKE EARLY ACTION to avoid collisions. Remember, PWCs and other boats do not have brakes.

DO NOT RELEASE THROTTLE WHEN TRYING TO STEER away from objects. Always check throttle and steering controls for proper operation before starting PWC.

Follow navigation rules and provincial/state and local laws that apply to PWCs. See Operator's Guide for more information.

Seating is limited to one operator and one passenger (xxx lbs. / xxx kg.).

219 901 757

XP DI Model Only

The location of these labels differ on the XP DI model.

Label 2

CAUTION/ ATTENTION	
Use Bombardier Formula XP-S II synthetic oil only. See Operator's guide.	219902055
Utiliser seulement l'huile synthétique Bombardier Formula XP-S II. Voir le guide du conducteur.	
F00A22Y	

Label 3

<p>"THIS BOAT IS NOT REQUIRED TO COMPLY WITH THE FOLLOWING U.S. COAST GUARD SAFETY STANDARDS IN EFFECT ON THE DATE OF CERTIFICATION:</p> <ul style="list-style-type: none"> ● Fuel System ● Safe Loading ● Display of Capacity Information ● Flotation ● Powered Ventilation <p>AS AUTHORIZED BY U.S. COAST GUARD GRANT OF EXEMPTION (CGB 88-001)."</p> <p>Bombardier Corp. 7575 Bombardier Court, Wausau, WI 54401</p>	
Made in Canada/Fabriqu� au Canada	Bombardier Inc. Rd./Enr.,1988
F02L2D0	

Label 4

Emission Control Information	
<p>This engine is certified to operate on unleaded regular gasoline and conforms to XXXX U.S. EPA regulations for Marine SI Engines.</p> <p style="text-align: right;">BOMBARDIER RECREATIONAL PRODUCTS</p>	
Engine Family:	XBCXM,XXXCR
FEL:	XXX gm/kW-hr HC + NO _x
Engine Displacement:	XXX cc
Exhaust Emission Control System:	XXX
Tune-Up Specifications	
Idle Speed:	XXXX RPM ± XXX
Spark Plug Type:	XXX
Spark Plug Gap:	XXX in./XXX mm
F00L29Y	

Emission Control Information	
<p>This engine conforms to MY XXXX U.S. EPA and California emission regulations for SI marine engines.</p> <p style="text-align: right;">BOMBARDIER RECREATIONAL PRODUCTS</p>	
Engine Family:	XBCXM,XXXCR
FEL:	XXX gm/kW-hr HC + NO _x
Engine Displacement:	XXX cc
Exhaust Emission Control System:	XXX
Spark Plug Type:	XXX
Spark Plug Gap:	XXX in./XXX mm
Power:	XXXX kW
See Operator's Guide for maintenance specifications	
F00L2XY	

Label 5

⚠ WARNING / AVERTISSEMENT	
DO NOT CHARGE OR BOOST THE BATTERY WHILE INSTALLED ON THE WATERCRAFT	
219902201	
NE PAS CHARGER OU SURVOLTER LA BATTERIE LORSQU'ELLE EST INSTALLÉE DANS LA MOTOMARINE	
F00A23Y	

Label 8

⚠ WARNING / AVERTISSEMENT	
<ul style="list-style-type: none"> • Gasoline vapors may cause fires or explosions. • Do not overfill fuel tank. • Keep the craft away from open flames and sparks. • Do not start watercraft if liquid gasoline or vapors are present. • Always replace seat (or engine cover) before starting. 	
<ul style="list-style-type: none"> • Les �mations d'essence peuvent provoquer des incendies ou des explosions. • �viter de trop remplir le r�servoir de carburant. • Garder la motomarine � l'�cart des flammes et des �tincelles. • Ne pas d�marrer la motomarine en pr�sence d'essence liquide ou d'�mation d'essence. • Toujours remettre le si�ge (ou le couvercle du compartiment-moteur) en place avant de d�marrer la motomarine. 	
219902202	
F00A27Y	

Label 9

⚠ WARNING	⚠ AVERTISSEMENT
Certain components in the engine compartment may be very hot. Direct contact may result in skin burn.	Certaines composantes dans l'habitacle du moteur peuvent �tre tr�s chaudes. Le contact direct sur la peau peut causer des br�lures.
F00A1AY	

Label 12

CAUTION / ATTENTION	
	<p>MAXIMUM OIL LEVEL</p> <p>NIVEAU D'HUILE MAXIMUM</p>
219902219	
F08G04Y	

LOCATION OF CONTROLS, COMPONENTS AND INSTRUMENTS

XP DI Model

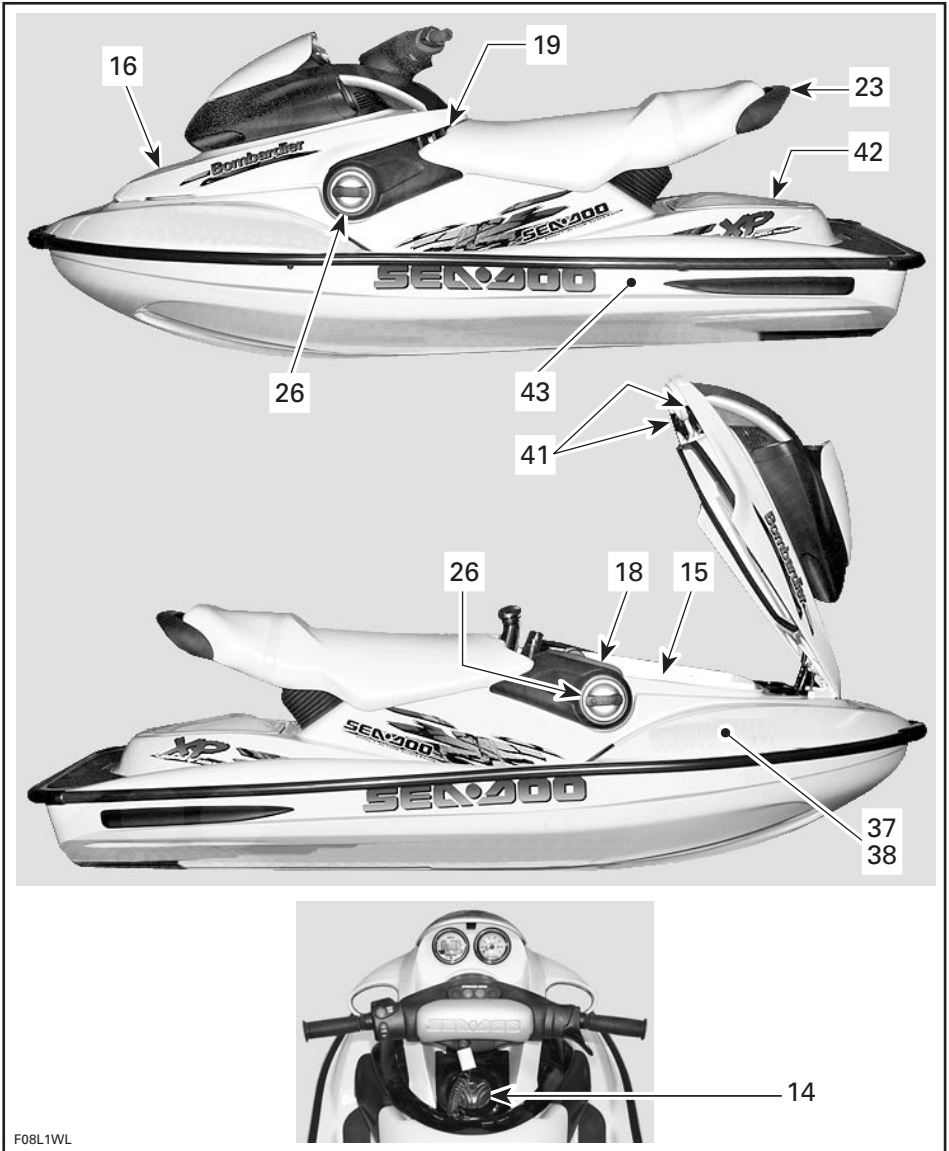

F08L1WL

TYPICAL

NOTE: Components not shown here are the same as on the RX DI models in the 2003 Sea-Doo Operator's Guide.

- 14) Fuel Tank Cap
- 15) Oil Injection Reservoir Cap
- 16) Front Storage Compartment Cover
- 18) Tool Kit
- 19) Air Intake Opening
- 23) Rear Grab Handle
- 26) Mooring Cleats
- 37) Fuses
- 38) Battery
- 41) Storage Compartment/Engine Cover Latches
- 42) Rear Access Cover
- 43) Automatic Bilge Pump

NOTE: Some components shown in the *2003 Sea-Doo Operator's Guide* do not apply to this watercraft. Refer to the following list:

- 7) Shift Lever
- 8) Fuel Gauge/Low Oil Warning Light
- 10) Tachometer
- 13) Fuel Tank Valve
- 17) Front Storage Compartment Cover Latch
- 20) Seat Strap
- 21) Seat Latch
- 22) Seat Extension Latch
- 24) Rear Storage Basket
- 30) Boarding Step
- 35) Reverse Gate
- 39) Side Vanes

FUNCTIONS OF CONTROLS, COMPONENTS AND INSTRUMENTS

The following components have the same operation as explained in the *2003 Operator's Guide*, only their location differ. To know where they are located, refer to the LOCATION OF CONTROLS, COMPONENTS AND INSTRUMENTS section in the previous pages.

- 14) Fuel Tank Cap
- 18) Tool Kit
- 19) Air Intake Opening
- 23) Rear Grab Handle

The following components are specific to the **XP DI models**. Refer to the following updated texts and/or illustrations.

15) Oil Injection Reservoir Cap

Open engine cover and remove storage tray.

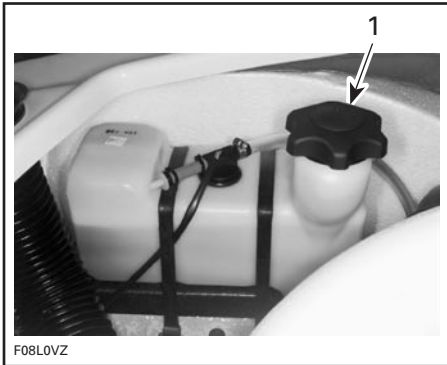

TYPICAL

1. Oil injection reservoir cap

To add injection oil in the reservoir, unscrew the cap counterclockwise.

Do not overfill. Make sure oil level does not exceed the level shown on the following drawing. Otherwise, siphon out the extra oil. Do not operate the engine when oil level exceeds the recommendation.

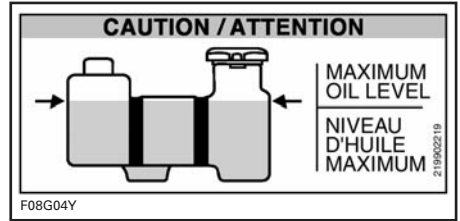

Reinstall cap and fully tighten it.

⚠ WARNING

Do not overfill. Never exceed the **MAX.** oil level line. Reinstall cap and fully tighten. Oil is inflammable. Always wipe off any oil spillage from the bilge.

16) Front Storage Compartment Cover

It gives access to the front storage compartment. Always relatch cover after closing.

The tray is provided with separate compartments.

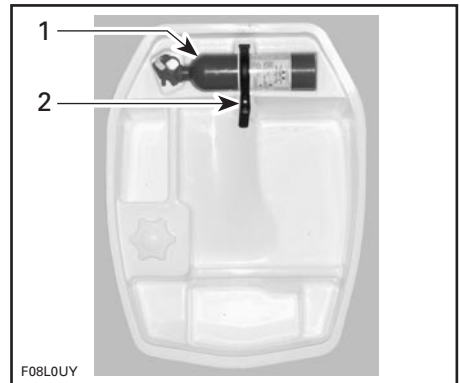

1. Fire extinguisher (sold separately)
2. Retaining strap

WARNING

Ensure to properly secure extinguisher with the supplied retaining straps.

26) Mooring Cleats

All Models

These cleats can be temporarily used for docking, while refueling for example.

CAUTION: Never use mooring cleats to pull or lift the watercraft.

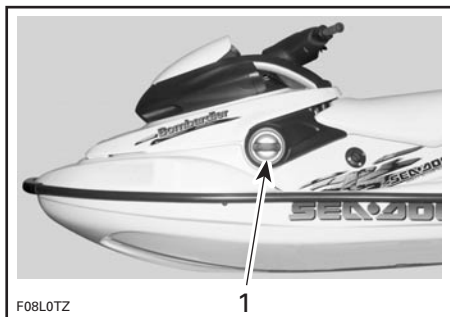

1. Mooring cleats

37) Fuses

Fuses are located in engine compartment. Refer to MAINTENANCE for more details.

38) Battery

Battery is located in bilge under seat. Refer to SPECIAL PROCEDURES.

41) Storage Compartment/ Engine Cover Latches

Pull both latch levers upward in order to open the storage compartment/engine cover. Always relatch cover on both sides.

NOTE: Verify periodically the lock pins tightness. Tighten if needed and make sure storage compartment/engine cover latches properly.

42) Rear Access Cover

It gives access to the battery, drive system, suspension, exhaust system and bailer pick-ups. Always relatch cover.

43) Automatic Bilge Pump

Bilge pump evacuates water from the bilge.

When safety lanyard cap is installed on its post, bilge pump automatically turns on. It will remain on until all water is evacuated, if any, then it will shut down automatically.

When engine is running, bilge pump will automatically start periodically to evacuate water.

OPERATING INSTRUCTIONS

Variable Trim System

The variable trim system (VTS) changes the angle of the jet pump nozzle to provide the operator with a fast, effective system to compensate for load, thrust, riding position and water conditions. Correctly adjusted, it can improve handling, reduce porpoising, and position the watercraft at its best riding angle to attain maximum performance.

When first using the watercraft, the operator should become familiar with the use of the variable trim system (VTS) at varying speeds and water conditions. A mid-range trim is generally used when cruising. Experience alone will dictate the best trim for the conditions. During the watercraft break-in period, when lower speeds are recommended, it is an excellent opportunity to gain familiarity of trim adjustment and its effects.

When the nozzle is positioned in an upward angle, the water thrust directs the bow of the watercraft upward. This position is used to optimize high speed.

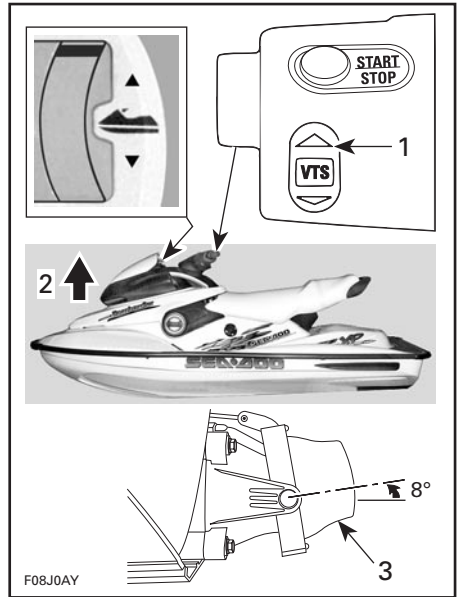

TYPICAL

1. Push on arrow pointing upward on VTS button
2. Bow up
3. Nozzle up

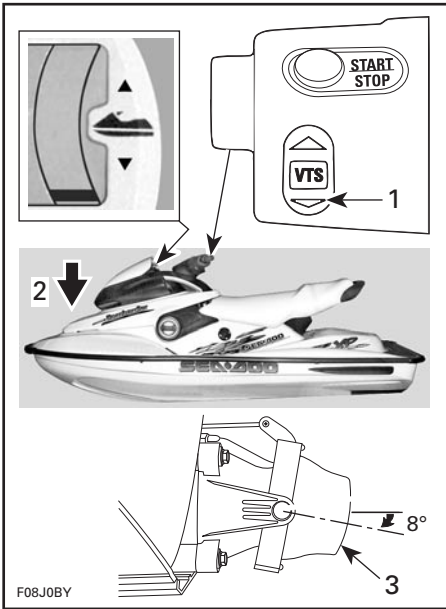

TYPICAL

1. Push on arrow pointing downward on VTS button
2. Bow down
3. Nozzle down

SPECIAL PROCEDURES

Towing the Watercraft in Water

It is the same as explained in the *2003 Operator's Guide*. The hose location and routing differs. Refer to the following updated text and illustration.

Remove rear access cover.

Install pincher as shown.

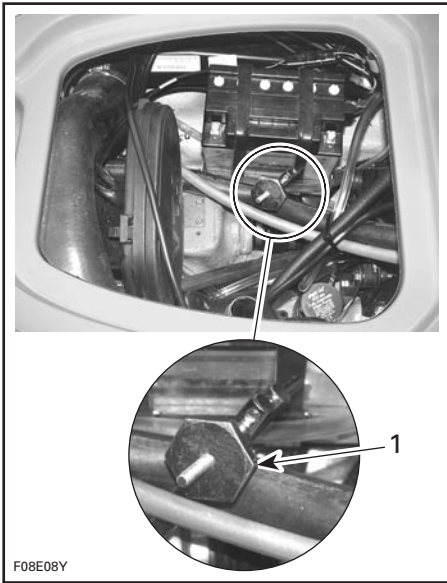

1. Hose pincher on water supply hose

Properly relatch cover.

CAUTION: When finished towing the watercraft, hose pincher should be removed before operating it. Failure to do so will result in damage to the engine.

MAINTENANCE

Lubrication

Seal Carrier

Using a grease gun, carefully lubricate seal carrier of mid bearing until grease is just coming out of seal.

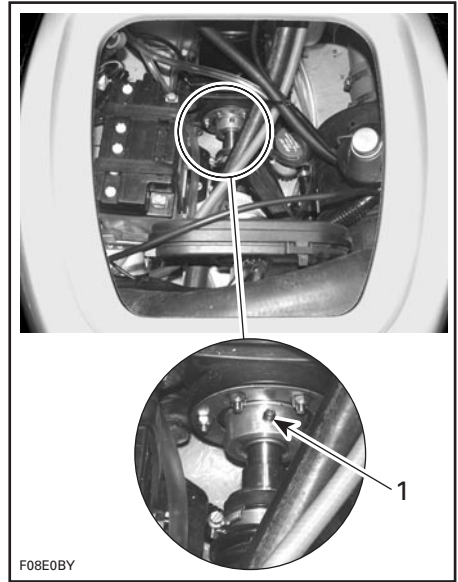

1. Grease seal carrier of mid bearing

Periodic Inspection Chart

The following is to be added for the XP DI models.

DESCRIPTION		FREQUENCY				
		FIRST 10 HOURS	EVERY 25 HOURS OR 3 MONTHS	EVERY 50 HOURS OR 6 MONTHS	EVERY 100 HOURS OR 1 YEAR	TO BE PERFORMED BY
PROPULSION SYSTEM	PTO flywheel and seal carrier	L	L			OPERATOR

Fuses

Refer to this updated text and illustrations.

Fuses can be found at 2 locations; on the MPEM and in the electrical box.

MPEM

To access fuses on the MPEM, open front storage compartment cover and remove storage tray.

Locate MPEM on the left side of watercraft.

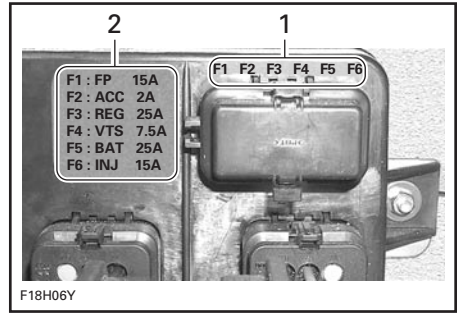

FUSE IDENTIFICATION

1. Fuse identification
2. Fuse description

Fuse identification: The fuses (F) are identified from 1 to 6.

Fuse description: The fuses are described with abbreviation as follows:

FP: Fuel pump

ACC: Accessories (information center)

REG: Regulator (charging system)

VTS: Variable Trim System

BAT: Battery

INJ: Injection system

The fuse description is followed by the ampere rating (A).

Reinstall storage tray and properly relatch storage compartment cover.

Electrical Box

To access fuses in the electrical box, open front storage compartment cover.

Locate electrical box on the right side of watercraft.

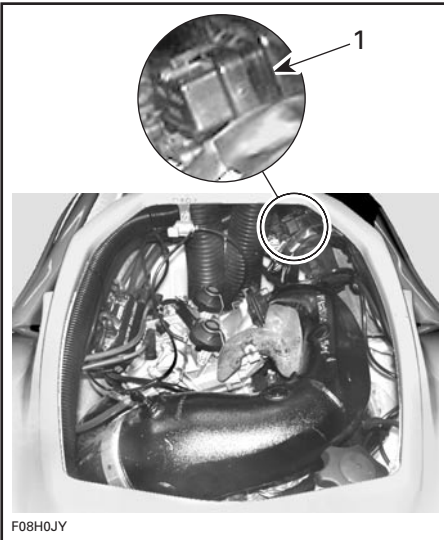

1. MPEM

Fuses are identified, look above and besides the fuse holder.

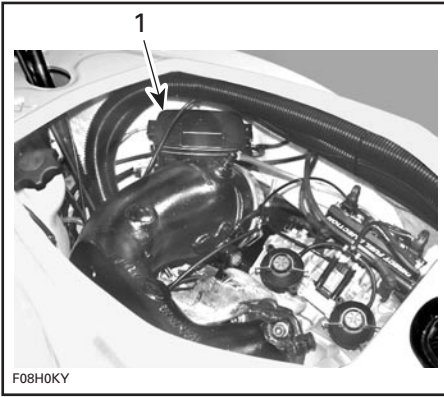

1. Electrical box

Unclip and remove cover of the electrical box to expose the holder of the main fuse.

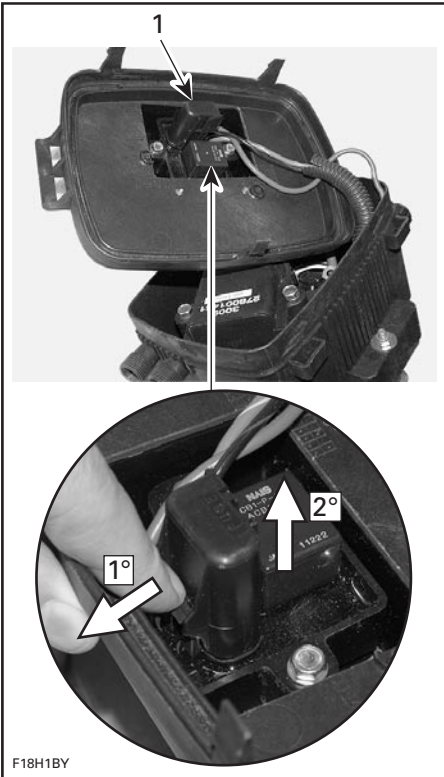

TYPICAL

1. Fuse holder

Electric bilge pump fuse is located at the bottom of the electrical box.

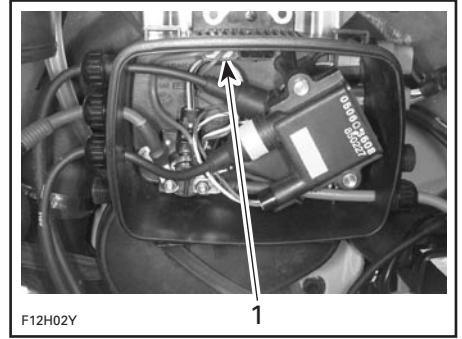

1. Electric bilge pump fuse

Properly reinstall removed components. Properly relatch storage compartment cover.

TRAILERING, STORAGE AND PRE-SEASON PREPARATION

The information pertaining to trailering, storage and pre-season preparation is similar to the one explained in the *2003 Operator's Guide*, except for the following updated text and illustrations.

Storage

Engine Draining

Remove rear access panel.

Check engine drain hose (the lowest one connected to the crankcase cooling outlet). Make sure there is no sand or other particles in it and that it is not obstructed so that water can exit the engine. Clean hose and fitting as necessary.

CAUTION: Water in engine drain hose should be free to flow out, otherwise water could be trapped in engine. Should water freeze in engine, severe damage will occur. Check engine drain hose for obstructions.

Disconnect the quick connect fitting. Press both tabs and pull fitting.

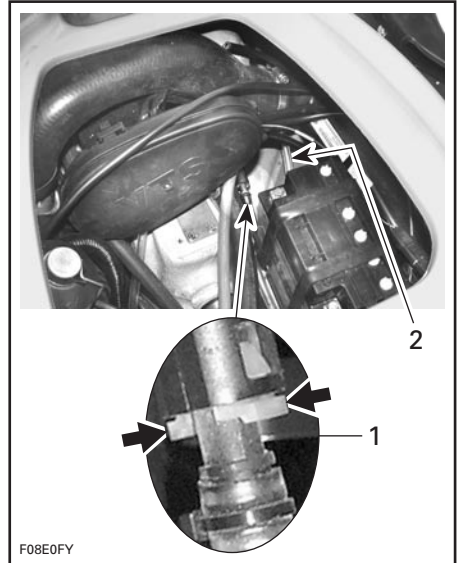

1. Disconnect engine drain hose (crankcase cooling outlet)
2. Air compressor drain line

Lower hose as necessary so that draining can take place.

Reconnect fitting when done.

Also ensure air compressor drain line is not obstructed. Clean as necessary. See illustration above.

Antifreezing Protection

NOTE: This procedure requires approximately 2.8 L (3 U.S. qt.) of antifreeze.

In cool regions where freezing point may be encountered, cooling system should be filled with an equal part of water and antifreeze solution.

CAUTION: Antifreeze mix must be fed in cooling system. Otherwise remaining water will freeze. This operation requires a good technical knowledge of the cooling system path. If antifreezing is not performed adequately engine/exhaust system may freeze and cause severe engine damage. We strongly recommend this operation be performed by an authorized SEA-DOO dealer.

CAUTION: Always use ethylene glycol antifreeze containing corrosion inhibitors specifically recommended for aluminum engines.

NOTE: When available, it is recommended to use biodegradable antifreeze compatible with internal combustion aluminum engines. This will contribute to protect the environment.

NOTE: The engine will not have to run during this operation but should have been ran before, to exhaust as much water as possible, from cooling system components.

Hose Pinchers Installation

Some hoses have to be plugged to prevent draining, before filling cooling system jackets with the antifreeze.

Install hose pinchers at the following location:

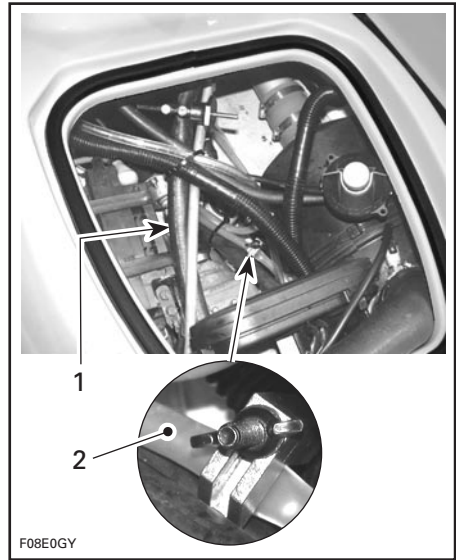

1. Water inlet hose
2. Engine cylinder drain hose (coming from underneath engine)

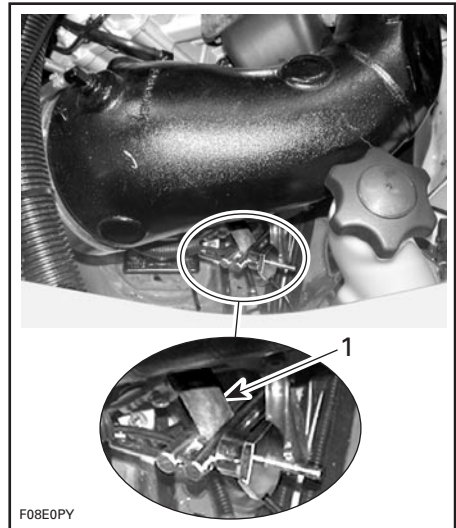

1. Water outlet hose underneath tuned pipe

Hose Disconnection

Disconnect the bottom hose at the water regulator valve on muffler.

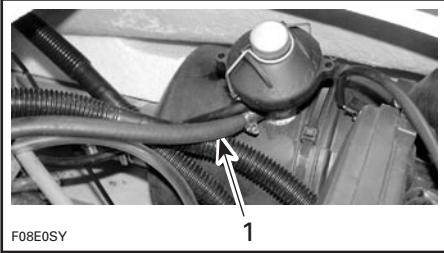

1. Disconnect the bottom hose from water regulator valve

Temporarily install a hose of approximately 1 m (3 ft) in length with a 12.7 mm (1/2 in) internal diameter over the previously disconnected hose.

Antifreeze

Insert a funnel into the temporary hose.

Ensure to hold the funnel approximately 1 m (3 ft) above the deck when pouring the antifreeze to create enough pressure so that it flows properly.

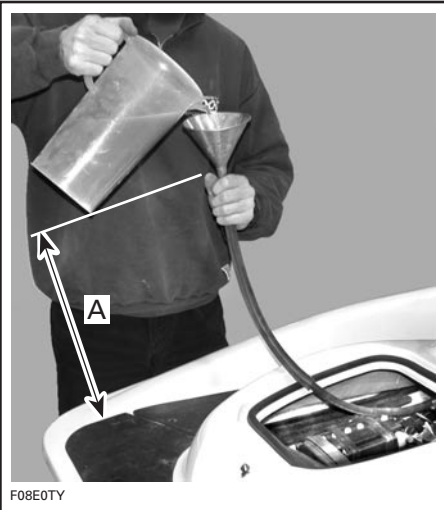

- A. 1 m (3 ft) to ease antifreeze flow

Pour antifreeze mix in engine until the colored solution appears at cooling system bleed outlet.

At this point, install a hose pincher on bleed outlet hose.

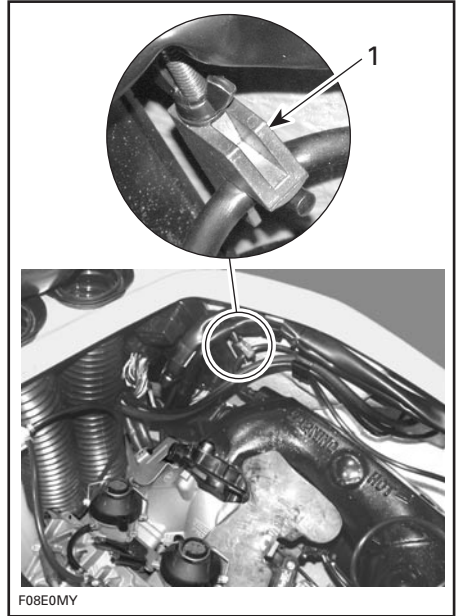

1. Bleed outlet hose

Continue to pour until antifreeze appears at the engine drain hose (crankcase cooling outlet). Then, install a hose pincher on this hose.

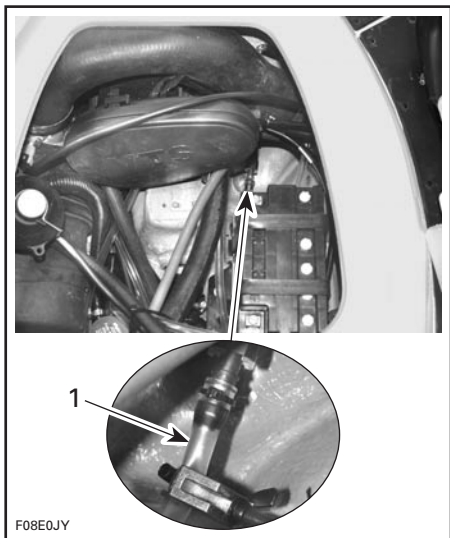

1. Engine drain hose (crankcase cooling outlet)

Continue to pour until antifreeze flows in air compressor water outlet hose.

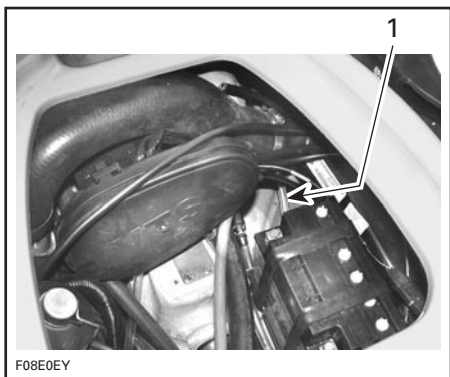

1. Air compressor water outlet hose

The pouring operation is over.

Remove pinchers in this order to allow proper flow of antifreeze.

NOTE: Most of the antifreeze will drain out when removing the hose pinchers. Use a container to recover it. **DISPOSE ANTIFREEZE AS PER YOUR LOCAL LAWS AND REGULATIONS.**

1. Bleed outlet hose.
2. Engine drain hose (crankcase cooling cover outlet).
3. Engine cylinder drain hose.
4. Water outlet hose.
5. Water inlet hose.

Install a temporary hose on the open fitting of the water regulator valve.

Pour approximately 200 mL (7 oz) of antifreeze in the temporary hose to allow antifreeze flowing through the water regulator valve and into muffler to protect it.

Remove temporary hoses and reconnect the factory hose to water regulator valve.

NOTE: Although antifreeze will mainly drain out, the antifreeze has mixed with the water that was possibly trapped in the water jackets and thus preventing freezing problems.

At pre-season preparation, drain the remaining antifreeze from cooling system prior to using the watercraft. Ensure no hose pincher was forgotten at storage.

The following steps should be performed to provide the watercraft enhanced protection.

Clean the bilge with hot water and detergent or with bilge cleaner. Rinse thoroughly. Lift front end of watercraft to completely drain bilge. If any repairs are needed to body or to the hull contact your authorized SEA-DOO dealer. For paint touch up to mechanical parts use Bombardier spray paint.

Final Steps

Refer to this updated text.

Apply a good quality marine wax to the body.

The seat should be partially left opened and the rear access cover and storage tray should be removed during storage. This will avoid engine compartment condensation and possible corrosion.

If the watercraft is to be stored outside, cover it with an opaque tarpaulin to prevent sun rays and grime from affecting the plastic components, watercraft finish as well as preventing dust accumulation.

CAUTION: The watercraft should never be left in water for storage. Never leave the watercraft stored in direct sunlight.

SPECIFICATIONS

ENGINE		XP DI (6130/6131)
Engine type		Rotax 947, 2-stroke
Induction type		Reed valve
Exhaust system		Water cooled/water injected with regulator
Exhaust valve		Rotax Adjustable Variable Exhaust (RAVE)
Lubrication	Type	Oil injection
	Oil type	BOMBARDIER Formula XP-S II synthetic injection oil
Number of cylinders		2
Displacement		951.2 cm ³ (58 in ³)
Rev limiter setting		7300 ± 50 RPM
COOLING		
Type		Open circuit. Direct flow from propulsion unit
ELECTRICAL		
Magneto generator output		270 W @ 6000 RPM
Ignition system type		Digital inductive
Spark plug	Make and type	NGK, ZFR4F
	Gap	1.1 mm (.043 in)
Starting system		Electric starter with reduction gear
Battery		12 V, 19 A•h
Fuse	Battery	25 A
	Main	30 A
	Charging system (REG)	25 A
	VTS system	7.5 A
	Information center (ACC)	2 A
	Injection system (INJ)	15 A
	Fuel pump (FP)	15 A
Bilge pump	3 A	
FUEL SYSTEM		
Fuel type		Regular unleaded gasoline with 87 octane minimum (R+M)/2
Fuel injection		Orbital direct fuel injection, twin throttle body (46 mm (1.81 in))

PROPULSION		XP DI (6130/6131)
Propulsion system		Bombardier Formula pump
Jet pump type		Axial flow, single stage
Transmission		Direct drive/split front and rear
Reverse system		No
Jet pump oil type		SEA-DOO synthetic polyolester oil SAE 75W90 GL5
Pivoting angle of direction (nozzle)		~ 20°
Minimum required water level for jet pump		90 cm (3 ft)
DIMENSIONS		
Number of passengers ①		2
Overall length		272 cm (107 in)
Overall width		112 cm (44.1 in)
Overall height		104 cm (40.6 in)
Weight		274 kg (605 lb)
Load limit (passengers + luggage)		181 kg (400 lb)
CAPACITIES		
Fuel tank		51 L (13.5 U.S. gal)
Fuel tank reserve (from low level signal)		9.8 L (2.6 U.S. gal)
Oil injection tank		4 L (1.1 U.S. gal)
Impeller shaft reservoir	Capacity	100 mL (3.4 U.S. oz)
	Oil level	Up to plug

① Refer to load limit.

BOMBARDIER INC. reserves the right to make changes in design and specifications and/or to make additions to, or improvements in its products without imposing any obligation upon itself to install them on its products previously manufactured.