



# SEA-DOO® 2003

OPERATOR'S GUIDE

**GTX 4-TEC**



## WARNING

Read this guide thoroughly.  
It important safety information.

®™ TRADEMARKS OF BOMBARDIER INC. OR ITS SUBSIDIARIES.  
©2003 BOMBARDIER INC. ALL RIGHTS RESERVED. PRINTED IN THE EU.

219 000 154



## **SAFETY WARNING**

Disregarding any of the safety precautions and instructions contained in this *Operator's Guide*, the *Safety Handbook*, the *Safety Videocassette* and on the on-product warning labels could cause injury, including the possibility of death. The operator has the responsibility to inform passenger(s) of safety precautions.

This *Operator's Guide*, the *Safety Handbook* and *Safety Videocassette* should remain with the craft at the time of resale.

**BOMBARDIER**  
*RECREATIONAL PRODUCTS*



Knight's Spray-Nine<sup>†</sup> is a trademark of Korkay System Ltd

GTXT<sup>†</sup> is a trademark of Castrol Ltd. used under license

**The following trademarks are the property of Bombardier Inc. or its subsidiaries:**

SEA-DOO<sup>®</sup>

BOMBARDIER-ROTAX<sup>®</sup>

BOMBARDIER LUBE<sup>®</sup>

BOMBARDIER Formula XP-S II Synthetic Injection Oil

BOMBARDIER-ROTAX Injection Oil

Sea-Doo Synthetic Grease

Sea-Doo LK<sup>™</sup>

Rotax<sup>®</sup>

O.P.A.S.<sup>™</sup>

T.O.P.S.<sup>™</sup>

Printed in the EU (Sea-Doo smo2003-003).

<sup>®</sup>™ Trademarks of Bombardier Inc. or its subsidiaries.

©2004 Bombardier Inc. All rights reserved.

## **Doin'it on your new SEA-DOO watercraft**

CONGRATULATIONS, YOU ARE NOW THE PROUD OWNER OF A SEA-DOO PERSONAL WATERCRAFT. WHETHER YOU ARE AN EXPERIENCED BOATER OR ARE NEW TO THE SPORT OF BOATING, WE ASK YOU TO TAKE THE TIME TO VIEW THE SAFETY VIDEOCASSETTE PROVIDED WITH THE WATERCRAFT, TO READ THIS *OPERATOR'S GUIDE*, THE *SAFETY HANDBOOK* AND ON-PRODUCT WARNING/CAUTION LABELS AND FAMILIARIZE YOURSELF WITH THE CONTENTS. THESE MANUALS CONTAIN PERTINENT INFORMATION WHICH, IF FOLLOWED, WILL PROVIDE YOU WITH THE NECESSARY KNOWLEDGE TO HELP YOU FULLY ENJOY THE PLEASURES OF THIS WATERCRAFT.

We strongly recommend that all watercraft operators complete a safety boating course. Check with your local Coast Guard or Power and Sail Squadron in your area for course availability. More serious boaters may want to obtain *Chapman Piloting* by Elbert S. Maloney, available at most book stores.

When introducing your family or friends to the sport, be sure they fully understand the controls and operation of the watercraft and the importance of courteous, responsible riding.

Each operator has a responsibility to ensure the safety of his/her passenger(s) and of other water users. Please follow all safety instructions and operate your craft with care.

We encourage you to have an Annual Safety Inspection of your watercraft. Please contact your dealer for further details.

Finally, we urge you to visit your dealer regularly for regular and safety maintenance as well as any watercraft accessories you may require.

Have fun and... Bon Voyage.

**PLEASE KEEP THIS guide and *SAFETY HANDBOOK* ON BOARD AT ALL TIMES. THESE MANUALS ALONG WITH THE *Safety Videocassette* SHOULD REMAIN WITH THE WATERCRAFT AT TIME OF RESALE.**

---

# TABLE OF CONTENTS

<b>TABLE OF CONTENTS</b> .....	<b>2</b>
<b>FOREWORD</b> .....	<b>6</b>
<b>SAFETY MEASURES</b> .....	<b>8</b>
General .....	8
Operation .....	8
Maintenance .....	10
<b>LIST OF DISTRIBUTORS</b> .....	<b>11</b>
<b>BOMBARDIER LIMITED WARRANTY INTERNATIONAL: SEA-DOO® WATERCRAFT</b> .....	<b>12</b>
<b>REGISTRATION NUMBER LOCATION</b> .....	<b>15</b>
<b>LOCATION OF THE IMPORTANT LABELS</b> .....	<b>16</b>
<b>IDENTIFICATION NUMBERS</b> .....	<b>20</b>
Hull.....	20
Engine.....	20
<b>CONTROLS, COMPONENTS AND INSTRUMENTS LOCATION</b> .....	<b>21</b>
<b>CONTROLS, COMPONENTS AND INSTRUMENTS FUNCTIONS</b> .....	<b>23</b>
1) Safety Lanyard (engine cut-off cord) .....	23
2) Handlebar .....	24
3) Throttle Lever.....	24
4) Engine Start/Stop Button .....	25
5) Shift Lever.....	25
6) Speedometer .....	26
7) Tachometer.....	26
8) Information Center Gauge/Buttons .....	26
9) Glove Box.....	30
10) Fuel Tank Cap .....	31
11) Front Storage Compartment Cover.....	31
12) Front Storage Compartment Cover Latch.....	32
13) Tool Kit .....	33
14) Air Intake Opening .....	33
15) Seat Strap .....	33
16) Seat Extension Latch .....	33
17) Seat Latch .....	33
18) Rear Grab Handle.....	34
19) Rear Storage Basket .....	34
20) Front and Rear (bow/stern) Eyelets .....	35
21) Mooring Cleats.....	35
22) Footboard.....	35
23) Boarding Pads .....	35
24) Boarding Platform .....	35
25) Boarding Step .....	36
26) Flushing Connector .....	36
27) Bilge Drain Plugs.....	37
28) Jet Pump Nozzle .....	37
29) Reverse Gate .....	38

30) Jet Pump Water Intake and Ride Plate.....	38
31) Fuses .....	39
32) Battery .....	39
33) Side Vanes .....	39
34) Engine Oil Dipstick .....	39
35) Engine Oil Filling Cap .....	40
36) Cooling System Expansion Tank Cap .....	40
Ski/Wake Board Post (if so equipped) .....	41
<b>LIQUIDS .....</b>	<b>42</b>
Fueling Procedure .....	42
Recommended Fuel .....	42
Engine Oil .....	43
Engine Coolant .....	45
<b>BREAK-IN PERIOD .....</b>	<b>47</b>
10-Hour Inspection .....	47
<b>PRE-OPERATION CHECKS .....</b>	<b>48</b>
Hull .....	49
Jet Pump Water Intake.....	49
Bilge .....	49
Battery.....	49
Fuel Tank.....	49
Engine Compartment .....	49
Engine Oil Level .....	50
Engine Coolant Level.....	50
Steering System.....	50
Throttle System.....	50
Shifter System.....	50
Storage Compartment Covers and Seat.....	50
Safety Lanyard and Engine Start/Stop Button .....	51
Water Flow in Exhaust Manifold (only when temperature is below or close to freezing point).....	51
<b>OPERATING INSTRUCTIONS .....</b>	<b>52</b>
Principle of Operation.....	52
Boarding the Watercraft .....	55
Starting .....	57
Rough Water or Poor Visibility Operation .....	58
Crossing Waves.....	58
Stopping / Docking .....	59
Beaching.....	59
Shutting Off the Engine.....	60
<b>POST-OPERATION CARE .....</b>	<b>61</b>
General Care.....	61
Additional Care for Foul Water or Salt Water .....	61
Exhaust Cooling System Flushing .....	61
Anticorrosion Treatment.....	63
<b>SPECIAL PROCEDURES.....</b>	<b>64</b>
Monitoring System .....	64
Engine Overheating.....	64

Engine Low Oil Pressure .....	64
Jet Pump Water Intake and Impeller Cleaning .....	65
Capsized Watercraft .....	66
Submerged Watercraft .....	66
Water-Flooded Engine .....	67
Fuel-Flooded Engine .....	67
Towing the Watercraft in Water .....	68
Low-Charge Battery Condition .....	69
<b>MAINTENANCE .....</b>	<b>70</b>
Engine Emissions Information .....	70
Lubrication .....	71
Periodic Inspection .....	71
Periodic Inspection Chart .....	72
Throttle Cable Inspection .....	74
Engine Oil Change and Oil Filter Replacement .....	74
Valve Adjustment .....	74
Coolant Replacement .....	74
Fuel Injection System .....	74
Steering Alignment .....	75
Vacuum Bailer Pick-Ups .....	75
Fuses .....	75
O.P.A.S. System (if so equipped) .....	78
Ski/Wake Board Post (if so equipped) .....	78
General Inspection and Cleaning .....	78
<b>TRAILERING, STORAGE AND PRE-SEASON PREPARATION .....</b>	<b>80</b>
Trailing .....	80
Launching/Loading .....	81
Storage .....	81
Pre-Season Preparation .....	84
<b>TROUBLESHOOTING .....</b>	<b>86</b>
<b>SPECIFICATIONS.....</b>	<b>92</b>
<b>SI* METRIC INFORMATION .....</b>	<b>95</b>
<b>ABBREVIATIONS USED IN THIS MANUAL.....</b>	<b>96</b>
<b>PRIVACY INFORMATION .....</b>	<b>97</b>
<b>CHANGE OF ADDRESS .....</b>	<b>98</b>

---

## FOREWORD

The *Operator's Guide* and *Safety Handbook* have been prepared to acquaint the owner/operator or passenger with this personal watercraft and its various controls, maintenance and safe riding instructions. Each is indispensable for the proper use of the product and should be kept in a waterproof bag with the watercraft at all times.

**MAKE SURE YOU READ AND UNDERSTAND THE CONTENT OF THE OPERATOR'S GUIDE AND SAFETY HANDBOOK.**

For any questions pertaining to the warranty and its application, consult the WARRANTY section in this guide, and/or an authorized Sea-Doo dealer.

This guide uses the following safety alert symbol in conjunction with signal words to indicate a potential personal injury hazard.

### **WARNING**

Indicates a potentially hazardous situation which, if not avoided, could result in death or serious injury.

### **CAUTION**

Indicates a potentially hazardous situation which, if not avoided, may result in minor or moderate injury. When used without the safety alert symbol , potential hazard exists for property damage only.

**NOTE:** Indicates supplementary information needed to fully complete an instruction.

Although the mere reading of such information does not eliminate the hazard, the understanding and application of the information will promote the correct use of the watercraft.

The information and components/ system descriptions contained in this guide are correct at the time of writing. Bombardier Inc. however, maintains a policy of continuous improvement of its products without imposing upon itself any obligation to install them on products previously manufactured.

Because of its ongoing commitment to product quality and innovation, Bombardier RESERVES THE RIGHT AT ANY TIME TO DISCONTINUE OR CHANGE SPECIFICATIONS, DESIGNS, FEATURES, MODELS OR EQUIPMENT WITHOUT INCURRING OBLIGATION.

The illustrations in this document show the typical construction of the different assemblies and may not represent the full detail or exact shape of the parts. However, they represent parts that have the same or similar function.

It is understood that this guide may be translated into another language. In the event of any discrepancy, the English version shall prevail.

Specifications are given in the SI metric system with the SAE U.S. equivalent in parenthesis. Where precise accuracy is not required, some conversions are rounded off for easier use.

A *Shop Manual* can be obtained for complete service, maintenance and more repair information.

The use of LEFT (port) and RIGHT (starboard) indications in the text, always refers to driving position (when sitting on watercraft).

Furthermore, in the marine industry, FRONT is referred to BOW and REAR as STERN.

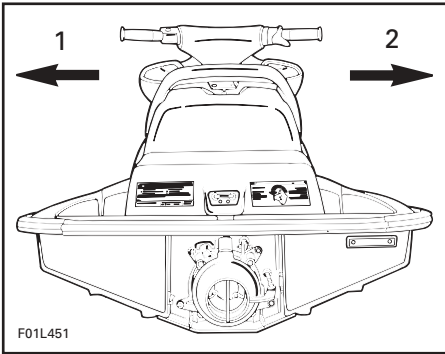

1. *Left (port)*
2. *Right (starboard)*



---

## **⚠ SAFETY MEASURES**

### **General**

- ⚠ To fully appreciate the pleasures, enjoyment and excitement of boating there are some basic rules that should be observed and followed by any rider. Some rules may be new to you or covered in the *Sea-Doo Safety Handbook* or *Safety Videocassette*, others may be common sense or obvious... irrespective, we ask that you please take a few minutes of your time to read these safety instructions completely together with your *Safety Handbook* before you operate your watercraft. **Failure to follow this safety information and safe boating rules could result in injury, including the possibility of death to you, your passenger(s), or other water users.**
- ⚠ Bombardier recommends not to operate a watercraft under the age of 16.
- ⚠ Become completely familiar with the controls and operation of the watercraft before embarking on your first trip or taking on a passenger(s). If you have not had the opportunity to do so with your authorized Sea-Doo dealer, practice driving solo in a suitable area and feel the response of each control. Be fully familiar with all controls before applying throttle above idle speed. As its operator, you control and are responsible for the watercraft's safe operation.

- ⚠ Always carry the regulatory required safety items on board. Check the local regulations or consult your authorized Sea-Doo dealer.
- ⚠ Make sure that all users of the watercraft read and understand all on-product warnings.

### **Operation**

- ⚠ Always perform the pre-operation checks as specified in this guide.
- ⚠ Operator and passenger(s) should at all times wear a coast guard approved personal flotation device (PFD) that is suitable for personal watercraft.
- ⚠ Operator and passenger(s) should wear protective clothing. Severe internal injuries can occur if water is forced into body cavities of males or females as a result of falling into water or being near jet thrust nozzle. Wet suit bottom (or thick, tightly woven, snug fitting clothing that provides equivalent protection. Thin bike shorts for example would not be appropriate), footwear, gloves and goggles/glasses are recommended.
- ⚠ Always keep in mind that as the throttle lever is released to idle position, less directional control is available. **To turn the watercraft, both steering and throttle are necessary.**

- ⚠ LIKE ANY OTHER CRAFT, THIS WATERCRAFT HAS NO BRAKE. STOPPING DISTANCE WILL VARY DEPENDING ON INITIAL SPEED, LOAD, WIND, AND WATER CONDITIONS. PRACTICE STOPPING AND DOCKING IN A SAFE, TRAFFIC FREE AREA TO HAVE AN IDEA OF HOW LONG IT WILL TAKE TO STOP THE WATERCRAFT UNDER VARYING CONDITIONS. DO NOT RELEASE THROTTLE WHEN TRYING TO STEER AWAY FROM OBJECTS. YOU NEED THROTTLE TO STEER. DO NOT USE THE WATERCRAFT'S REVERSE, IF SO EQUIPPED, TO STOP.
- ⚠ Ensure that all passengers know how to swim and how to reboard the watercraft from the water.
- ⚠ The operator and passenger(s) should be properly seated before starting or moving the watercraft, and at all times when watercraft is in motion.
- ⚠ **Do not** start or operate the watercraft if someone is seated on the sun deck (if so equipped) or swim platform, or is nearby in the water. The watercraft's jet thrust can cause injury. Always accelerate slowly.
- ⚠ To prevent accidental starting or unauthorized use, always detach the safety lanyard from the watercraft especially when swimmers are boarding or nearby, or during removal of any weeds or debris from the intake grate.
- ⚠ Never turn handlebar while someone is nearby rear of watercraft. Keep away from steering moving parts (nozzle, side vanes, linkage, etc.).
- ⚠ Keep away from intake grate while engine is on. Items such as long hair, loose clothing, or PFD straps can become entangled in moving parts resulting in severe injury or drowning.
- ⚠ Ride within your limits and avoid aggressive maneuvers to reduce the risk of loss of control, ejection and collision.
- ⚠ Riding with a passenger(s) or pulling other crafts, tubes, skies or wakeboards makes the watercraft handle differently and requires greater skill. Do not overload the watercraft or take on more passengers than designated for the particular watercraft. Overloading can affect maneuverability, stability and performance.
- ⚠ Avoid adding on accessories, or equipment which may alter the configuration, balance or control of the watercraft. The watercraft maybe fitted with tow eyelets which can be used to attach a ski rope. However, do not use these eyelets or the watercraft's cleats to tow a parasail. Severe injury or watercraft damage may occur.
- ⚠ In shallow water, proceed with caution and at very low speeds. Grounding or abrupt stops may result in injury. Debris may also be picked up and be thrown rearward by the jet pump onto people or property.

- ⚠ RESPECT NO WAKE ZONES, THE RIGHTS OF OTHER WATER USERS AND THE ENVIRONMENT. AS THE “SKIPPER” AND OWNER OF A WATERCRAFT YOU ARE RESPONSIBLE FOR DAMAGE TO OTHER CRAFTS CAUSED BY THE WAKE OF YOUR WATERCRAFT. ALLOW NO ONE TO THROW REFUSE OVERBOARD.
- ⚠ REMEMBER THAT A WATERCRAFT IS NOT DESIGNED FOR NIGHT TIME OPERATION.
- ⚠ Remember, gasoline fumes are flammable and explosive. Always adhere to the fueling procedure contained in this guide and those given to you by the marina. Always verify fuel level before use and during the ride. Apply the principle of 1/3 fuel to destination, 1/3 back and 1/3 reserve fuel supply. Do not carry spare fuel or flammable liquids in any of the storage or engine compartments.
- ⚠ Combustion engine needs air to operate; consequently this watercraft can not be totally watertight. Any maneuvers such as figure eights etc., that cause the upper deck to be under water may cause severe engine problems due to water ingestion. Refer to Special procedures and LIMITED WARRANTY contained in this guide.
- ⚠ Due to the close proximity of other racers, it is recommended that an approved personal watercraft helmet be used during racing events. Read and follow all instructions and warnings provided with the helmet.
- ⚠ Never ride after consuming drugs or alcohol or if you feel tired or ill. Operate your watercraft prudently and have fun.
- ⚠ Don't forget that all persons must assist other boaters in an emergency.



## Maintenance

- ⚠ Only perform servicing procedures which are detailed in this guide. Further assistance or information can be obtained from your authorized Sea-Doo dealer. In many instances proper tools and training is required for certain servicing or repair procedures.
- ⚠ Maintain the watercraft and equipment in top condition at all times. Adhere to the prescribed maintenance schedules. An annual inspection of the watercraft is always a good recommendation that should be followed.
- ⚠ Always use spark plug cable grounding device when removing spark plugs (if so equipped).
- ⚠ The bilge should be kept clean of oil, water or other foreign materials.
- ⚠ DO NOT ATTEMPT TO LIFT THE WATERCRAFT WITHOUT SPECIAL EQUIPMENT AND TRAINING.
- ⚠ The engine and the corresponding components identified in this guide should not be utilized on product(s) other than for those they were designed. Maintenance procedures and specified tightening torque should be strictly adhered to. Never attempt repairs unless the appropriate tools are available. These watercrafts are designed with parts dimensioned in both the metric and the imperial systems. When replacing fasteners, make sure to use only those recommended by Bombardier. If required, contact your authorized Sea-Doo dealer for further servicing information.

---

# LIST OF DISTRIBUTORS

## NORTH AMERICA

<p><b>USA</b></p>  <p>(except Puerto Rico)</p>	<p><b>BOMBARDIER MOTOR CORPORATION OF AMERICA</b> 7575 Bombardier Court WAUSAU, WI. 54401 Phone: (715) 848-4957 Fax: (715) 847-6879 <a href="http://www.bombardier.com">www.bombardier.com</a></p>
<p><b>CANADA</b></p> 	<p><b>BOMBARDIER INC.</b> RECREATIONAL PRODUCTS 75 J. A. BOMBARDIER ST. SHERBROOKE, QC J1L 1W3 Phone: (819) 566-3366 Fax: (819) 566-3062 <a href="http://www.bombardier.com">www.bombardier.com</a></p>

If your Sea-Doo watercraft requires warranty service, you should take it to any authorized Sea-Doo dealer. Be sure to bring your warranty registration card or other valid proof of the original date of purchase. If a question or problem arises regarding warranty, first contact the service manager or owner of the Sea-Doo dealership.

To find the nearest authorized Sea-Doo dealer, dial: 1-800-882-2900.

**NOTE:** If outside Canada or USA, consult your local authorized Sea-Doo distributor.

---

# **BOMBARDIER LIMITED WARRANTY INTERNATIONAL: SEA-DOO® WATERCRAFT**

## **1. SCOPE OF THE LIMITED WARRANTY**

BOMBARDIER INC. (hereinafter "BOMBARDIER") warrants its SEA-DOO personal watercraft from defects in material or workmanship for the period described below.

All genuine BOMBARDIER parts and accessories, installed by an authorized BOMBARDIER distributor/dealer (as hereinafter defined) at the time of delivery of the SEA-DOO personal watercraft, carry the same warranty as that of the personal watercraft.

Use of the product for racing or any other competitive activity, at any point, even by a prior owner will render this warranty null and void.

## **2. WARRANTY COVERAGE PERIOD**

This warranty will be in effect FROM THE DATE OF DELIVERY TO THE FIRST RETAIL CONSUMER or the date the product is first put into use, whichever occurs first and for a period of:

(a) TWELVE (12) CONSECUTIVE MONTHS, for private use owners <sup>(1)</sup>.

(b) FOUR (4) CONSECUTIVE MONTHS, for commercial use owners.

The repair or replacement of parts or the performance of service under this warranty does not extend the life of this warranty beyond its original expiration date.

## **3. CONDITIONS TO HAVE WARRANTY COVERAGE**

THIS WARRANTY COVERAGE IS AVAILABLE ONLY ON SEA-DOO PERSONAL WATERCRAFT PURCHASED AS NEW AND UNUSED BY ITS FIRST OWNER FROM A BOMBARDIER DISTRIBUTOR/DEALER AUTHORIZED TO DISTRIBUTE SEA-DOO PRODUCTS IN THE COUNTRY IN WHICH THE SALE OCCURRED (HEREINAFTER "BOMBARDIER distributor/dealer"), and then only after the specified predelivery inspection process is completed and documented. Warranty coverage only becomes available upon proper registration of the product by a BOMBARDIER dealer. Such limitations are necessary in order to allow BOMBARDIER to preserve both the safety of its products, and also that of its consumers and the public.

Routine maintenance outlined in the *Operator's Guide* must be timely performed in order to maintain warranty coverage. BOMBARDIER reserves the right to make warranty coverage contingent upon proof of proper maintenance.

1. The warranty is TWENTY FOUR (24) consecutive months if the product was sold in any of the member states of the European Union (EC directive 1999/44/EC).

The warranty period, however, is FOUR (4) consecutive months if the product is used for commercial purposes.

#### **4. WHAT TO DO TO OBTAIN WARRANTY COVERAGE**

The customer must notify a servicing BOMBARDIER distributor/dealer within two (2) days of the appearance of a defect, and provide it with reasonable access to the product and reasonable opportunity to repair it. The customer must also present to the BOMBARDIER distributor/dealer, proof of purchase of the product and must sign the repair/work order prior to the start of the repair in order to validate the warranty repair. All parts replaced under this limited warranty become the property of BOMBARDIER.

#### **5. WHAT BOMBARDIER WILL DO**

BOMBARDIER's obligations under this warranty are limited to, at its sole discretion, repairing parts found defective under normal use, maintenance and service, or replacing such parts with new genuine BOMBARDIER parts without charge for parts and labor, at any authorized BOMBARDIER distributor/dealer.

BOMBARDIER reserves the right to improve or modify products from time to time without assuming any obligation to modify products previously manufactured.

#### **6. EXCLUSIONS - ARE NOT WARRANTED**

- Normal wear and tear;
- Routine maintenance items, tune ups, adjustments;
- Damage caused by failure to provide proper maintenance and/or storage, as described in the *Operator's Guide*;
- Damage resulting from removal of parts, improper repairs, service, maintenance, modifications or use of parts not manufactured or approved by BOMBARDIER or resulting from repairs done by a person that is not an authorized servicing BOMBARDIER distributor/dealer;
- Damage caused by abuse, abnormal use, neglect or operation of the product in a manner inconsistent with the recommended operation described in the *Operator's Guide*;
- Damage resulting from accident, submersion, fire, theft, vandalism or any act of God;
- Operation with fuels, oils or lubricants which are not suitable for use with the product (see the *Operator's Guide*);
- Water ingestion;
- Damages related to gel coat finish including but not limited to cosmetic gel coat finish, blisters or fiberglass delamination caused by blisters, crazing, spider or hairline cracks; and
- Incidental or consequential damages, or damages of any kind including without limitation towing, storage, telephone, rental, taxi, inconvenience, insurance coverage, loan payments, loss of time, loss of income.

## **7. LIMITATIONS OF LIABILITY**

THIS WARRANTY IS EXPRESSLY GIVEN AND ACCEPTED IN LIEU OF ANY AND ALL OTHER WARRANTIES, EXPRESSED OR IMPLIED, INCLUDING WITHOUT LIMITATION ANY WARRANTY OF MERCHANTABILITY OR FITNESS FOR A PARTICULAR PURPOSE. TO THE EXTENT THAT THEY CANNOT BE DISCLAIMED, THE IMPLIED WARRANTIES ARE LIMITED IN DURATION TO THE LIFE OF THE EXPRESS WARRANTY. INCIDENTAL AND CONSEQUENTIAL DAMAGES ARE EXCLUDED FROM COVERAGE UNDER THIS WARRANTY. SOME COUNTRIES DO NOT ALLOW FOR THE DISCLAIMERS, LIMITATIONS AND EXCLUSIONS IDENTIFIED ABOVE, AS A RESULT, THEY MAY NOT APPLY TO YOU. THIS WARRANTY GIVES YOU SPECIFIC RIGHTS, AND YOU MAY ALSO HAVE OTHER LEGAL RIGHTS WHICH MAY VARY FROM COUNTRY TO COUNTRY.

Neither the BOMBARDIER distributor nor any other person has been authorized to make any affirmation, representation or warranty regarding the product, other than those contained in this limited warranty, and if made, shall not be enforceable against BOMBARDIER.

BOMBARDIER reserves the right to modify this warranty at any time, being understood that such modification will not alter the warranty conditions applicable to the products sold while this warranty is in effect.

## **8. TRANSFER**

If the ownership of a product is transferred during the warranty coverage period, this warranty shall also be transferred and be valid for the remaining coverage period provided that BOMBARDIER is notified of such transfer of ownership in the following way:

- (a) The former owner contacts BOMBARDIER or an authorized BOMBARDIER distributor/ dealer and gives the coordinates of the new owner; or
- (b) BOMBARDIER or an authorized BOMBARDIER distributor/dealer receives a proof that the former owner agreed to the transfer of ownership, in addition to the coordinates of the new owner.

## **9. CONSUMER ASSISTANCE**

- (a) In the event of a controversy or a dispute in connection with this BOMBARDIER LIMITED WARRANTY, BOMBARDIER suggests that you try to resolve the issue at the distributor-ship/dealership level. We recommend discussing the issue with the authorized dealer's service manager or owner.
- (b) If further assistance is required, the distributor's service department should be contacted in order to resolve the matter.

© 2003 Bombardier Inc. All rights reserved

® Registered trademark of Bombardier Inc. or its subsidiaries.

---

## REGISTRATION NUMBER LOCATION

All personal watercraft are required by federal law to be registered and legally numbered. Due to space availability for proper display of registration number, refer to following illustration for location. The registration number should appear on each side of the watercraft. On applicable models install registration number to the left of the star label.



### 1. Registration number location

**NOTE:** The registration number must be above the water line. Ensure also that the numbers are of the correct size and color. Check with local applicable regulations.



# LOCATION OF THE IMPORTANT LABELS

The following labels are on your watercraft. If missing or damaged, they can be replaced free of charge. See an authorized Sea-Doo dealer.

Please read the following labels carefully before operating this watercraft.

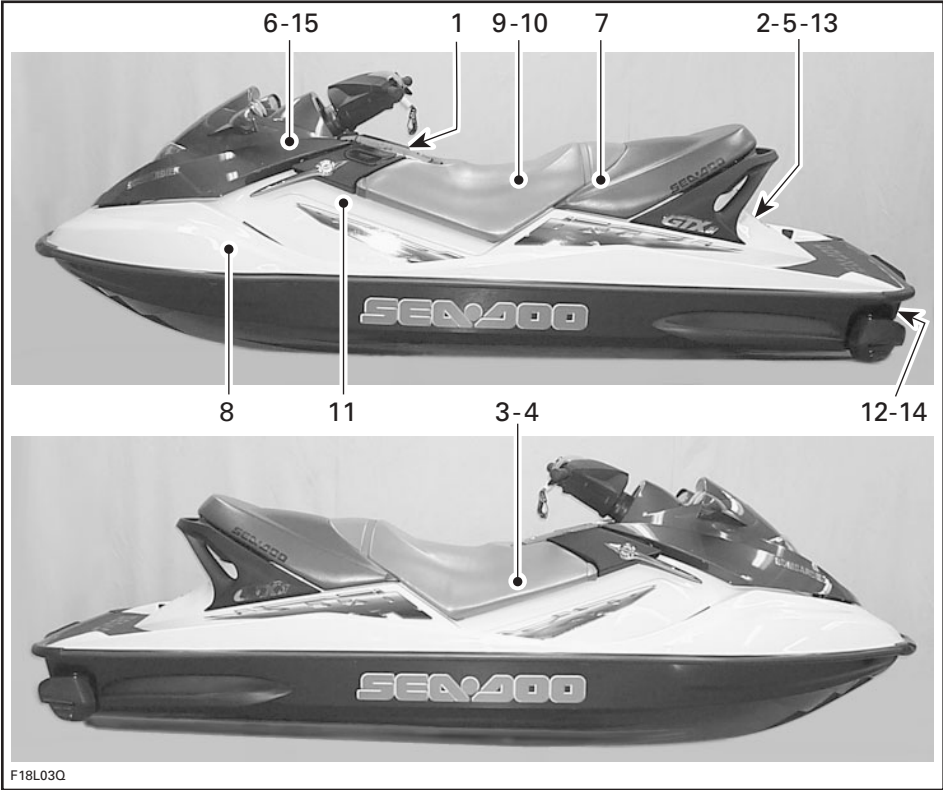

TYPICAL

# Label 1

## ⚠ WARNING

To reduce the risk of SEVERE INJURY or DEATH:

**WEAR A PERSONAL FLOTATION DEVICE (PFD).** All riders must wear a Coast Guard approved PFD that is suitable for personal watercraft (PWC) use.

**WEAR PROTECTIVE CLOTHING.** Severe internal injuries can occur if water is forced into body cavities as a result of falling into water or being near jet thrust nozzle. Normal swimwear does not adequately protect against forceful water entry into lower body opening(s) of males or females. All riders must wear a wet suit bottom or clothing that provides equivalent protection (see Operator's Guide). Footwear, gloves and goggles/glasses are recommended.

**KNOW BOATING LAWS.** Bombardier recommends a minimum operator age of 16 years old. Know the operator age and training requirements for your province/state. A boating safety course is recommended and may be required in your province/state.

**ATTACH ENGINE SHUT-OFF CORD (LANYARD) to PFD** and keep it free from handlebars so that engine stops if operator falls off. After riding, remove cord from PWC to avoid unauthorized use by children or others.

**RIDE WITHIN YOUR LIMITS AND AVOID AGGRESSIVE MANEUVERS** to reduce the risk of loss of control, ejection and collision. This is a high performance boat - not a toy. Sharp turns or jumping wakes or waves can increase the risk of back/spinal injury (paralysis), facial injuries, and broken legs, ankles, and other bones. **Do not jump wakes or waves.**

**DO NOT APPLY THROTTLE WHEN ANYONE IS AT REAR OF PWC** - turn engine off or keep engine at idle. Water and/or debris exiting jet thrust nozzle can cause severe injury.

**KEEP AWAY FROM INTAKE GRATE** while engine is on. Items such as long hair, loose clothing, or PFD straps can become entangled in moving parts resulting in severe injury or drowning.

**NEVER RIDE AFTER CONSUMING DRUGS OR ALCOHOL**

**READ AND FOLLOW OPERATOR'S GUIDE**

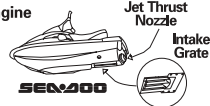

## ⚠ WARNING

Collisions result in more INJURIES AND DEATHS than any other type of accident for personal watercraft (PWC).

**TO AVOID COLLISIONS:**

**SCAN CONSTANTLY** for people, objects, and other watercraft. Be alert for conditions that limit your visibility or block your vision of others.

**OPERATE DEFENSIVELY** at safe speeds and keep a safe distance away from people, objects, and other watercraft.

- Do not follow directly behind PWCs or other boats.
- Do not go near others to spray or splash them with water.
- Avoid sharp turns or other maneuvers that make it hard for others to avoid you or understand where you are going.
- Avoid areas with submerged objects or shallow water.

**TAKE EARLY ACTION** to avoid collisions. Remember, PWCs and other boats **do not have brakes.**

**DO NOT RELEASE THROTTLE WHEN TRYING TO STEER** away from objects - **you need throttle to steer.** Always check throttle and steering controls for proper operation before starting PWC.

Follow navigation rules and province/state and local laws that apply to PWCs. See Operator's Guide for more information. Seating is limited to XX operator and XX passengers (XXX lbs./XXX kg.).



219 901 713

F12L0FL

## Label 2

"THIS BOAT IS NOT REQUIRED TO COMPLY WITH THE FOLLOWING U.S. COAST GUARD SAFETY STANDARDS IN EFFECT ON THE DATE OF CERTIFICATION:

- Fuel System
- Safe Loading
- Display of Capacity Information
- Flotation
- Powered Ventilation

AS AUTHORIZED BY U.S. COAST GUARD GRANT OF EXEMPTION (CGB 88-001)."

Bombardier Corp. 7575 Bombardier Court, Wausau, WI 54401

Made in Canada/Fabriqu  au Canada Bombardier Inc. Rd./Enr., 1988

F02L2D0

## Label 3

### Emission Control Information



This engine conforms to MY XXXX U.S. EPA and California emission regulations for SI marine engines.

**BOMBARDIER**  
RECREATIONAL PRODUCTS

Engine Family: ..... XBCM.XXXXCR  
 FEL: ..... XXX gm/kW-hr HC + NO<sub>x</sub>  
 Engine Displacement: ..... XXX cc  
 Exhaust Emission Control System: ..... XXX

Spark Plug Type: ..... XXX  
 Spark Plug Gap: ..... XXX in./XXX mm  
 Power: ..... XXXX kW

See Operator's Guide for maintenance specifications

F00L2XY

## Label 4

### ⚠ WARNING / AVERTISSEMENT

**DO NOT CHARGE OR BOOST THE BATTERY WHILE INSTALLED ON THE WATERCRAFT**

219902201

**NE PAS CHARGER OU SURVOLTER LA BATTERIE LORSQU'ELLE EST INSTALL E DANS LA MOTOMARINE**

F00A23Y

## Label 5

▲ WARNING / AVERTISSEMENT	
<ul style="list-style-type: none"> <li>• Engine must be off when using boarding step.</li> <li>• Keep away from jet and intake grate.</li> <li>• Stay on center of the step.</li> <li>• Only one person at a time on the step.</li> <li>• Never use the step for pulling, towing, diving or jumping, boarding a PWC that is out of water or any other purpose for which it was not designed.</li> </ul>	12060303
<ul style="list-style-type: none"> <li>• Le moteur doit être arrêté lorsqu'on utilise la marche d'embarquement.</li> <li>• Se tenir à l'écart de la turbine et de la grille d'admission.</li> <li>• Rester au centre de la marche.</li> <li>• Une personne à la fois sur la marche.</li> <li>• La marche ne doit jamais servir à tirer ou à remorquer la motomarine, à plonger, à sauter à l'eau, à embarquer sur la motomarine si elle n'est pas à l'eau ou pour toute autre activité pour laquelle elle n'a pas été conçue.</li> </ul>	

F00A26Y

## Label 6

▲ WARNING / AVERTISSEMENT	
<ul style="list-style-type: none"> <li>• Gasoline vapors may cause fires or explosions.</li> <li>• Do not overfill fuel tank.</li> <li>• Keep the craft away from open flames and sparks.</li> <li>• Do not start watercraft if liquid gasoline or vapors are present.</li> <li>• Always replace seat (or engine cover) before starting.</li> </ul>	219902202
<ul style="list-style-type: none"> <li>• Les émanations d'essence peuvent provoquer des incendies ou des explosions.</li> <li>• Éviter de trop remplir le réservoir de carburant.</li> <li>• Garder la motomarine à l'écart des flammes et des étincelles.</li> <li>• Ne pas démarrer la motomarine en présence d'essence liquide ou d'émanation d'essence.</li> <li>• Toujours remettre le siège (ou le couvercle du compartiment-moteur) en place avant de démarrer la motomarine.</li> </ul>	

F00A27Y

## Label 7

▲ WARNING	▲ AVERTISSEMENT
<p>Certain components in the engine compartment may be very hot. Direct contact may result in skin burn.</p>	<p>Certaines composantes dans l'habitacle du moteur peuvent être très chaudes. Le contact direct sur la peau peut causer des brûlures.</p>

F00A1AY

## Label 8



SOME MODELS

## Label 9

▲ WARNING / AVERTISSEMENT	
<p>When disconnecting coil from sparkplug, always disconnect coil from main harness first. Never check for engine ignition spark from an open coil and/or sparkplug in the engine compartment as spark may cause fuel vapor to ignite.</p>	F18L0NY
<p>Lorsque vous déconnectez la bobine d'allumage de la bougie, toujours déconnecter la bobine d'allumage du harnais principal en premier. Ne jamais vérifier si le circuit d'allumage du moteur produit une étincelle en utilisant la bobine d'allumage et/ou la bougie dans le compartiment moteur car une étincelle pourrait entraîner l'allumage des vapeurs d'essence.</p>	

## Label 10

▲ WARNING / AVERTISSEMENT	
<p><b>CHECKING ENGINE OIL LEVEL</b></p> <p>Vehicle must be level to perform verification. Bring engine to normal operating temperature then let idle for 30 seconds. Stop engine, wait for at least 30 sec. and check oil level using the dipstick. Caution: Never let the engine run out of the water without cooling through the flush kit connection as it may damage the engine. Oil may be hot.</p>	
<p><b>VÉRIFICATION DU NIVEAU D'HUILE DU MOTEUR</b></p> <p>Avec la motomarine à niveau et à température normale d'utilisation, laisser le moteur tourner au ralenti 30 secondes. Arrêter le moteur, attendre au moins 30 sec. et vérifier le niveau d'huile. Attention: Ne pas laisser tourner le moteur hors de l'eau sans faire circuler de l'eau par le raccord de rinçage. L'huile peut être chaude.</p>	

F18L10Y

## Label 11

CAUTION	
<ul style="list-style-type: none"> <li>• To comply with noise regulations, this engine is designed to operate with an air intake silencer.</li> <li>• Operation without air intake silencer or with one not properly installed may cause engine damage.</li> </ul>	
ATTENTION	
<ul style="list-style-type: none"> <li>• Le moteur a été conçu pour fonctionner avec ce silencieux d'admission afin de se conformer aux lois et règlements relatifs au bruit.</li> <li>• Son absence ou une mauvaise installation peut endommager le moteur.</li> </ul>	



A01A2EY 516 001 191

## Label 12

▲ WARNING	
<p>When operating the engine while the watercraft is out of the water, the heat exchanger in the ride plate may become very hot. Avoid any contact with ride plate as burns may occur.</p>	
▲ AVERTISSEMENT	
<p>Faire fonctionner le moteur quand le véhicule est hors de l'eau peut rendre le radiateur incorporé à la plaque promenade très chaud. Éviter tout contact avec la plaque de promenade, des brûlures peuvent survenir.</p>	

F18L0YY 219231.07

## Label 13

 <b>WARNING</b>	 <b>AVERTISSEMENT</b>
<b>Make sure ski post is fully extended and locked before use. Completely retract when not used.</b>	<b>S'assurer que le poteau de fixation du câble de ski nautique est déployé et verrouillé avant de l'utiliser. Lorsqu'on ne l'utilise pas, le poteau doit être rangé.</b>
F18A05Y	

SOME MODELS

## Label 14

<p>This product may be covered by one or more of the following US patents and/or applications and their non-US equivalents / Ce produit peut être protégé aux États-Unis par un ou plusieurs des brevets et/ou demandes de brevet ci-après, ainsi que par leurs équivalents à l'extérieur des États-Unis: 6,283,099; 6,276,291; 6,174,210; 6,102,756; 6,019,648; 5,746,054; 5,603,281; 5,542,371; 5,369,360; D399,182; D343,160; D326,839.</p> <p>BOMBARDIER, SEA-DOO, XP, RX, RXX, GTI, GTS, Learning Key, OPAS, TOPS, and their associated graphic designs are trademarks of Bombardier Inc. ROTAX, 4-TEC, RFI, and their associated graphic designs are trademarks of Bombardier-Rotax GmbH &amp; Co KG used under license. GTX is a trademark of Castrol Limited used under license. BOMBARDIER, SEA-DOO, XP, RX, RXX, GTI, GTS, Learning Key, OPAS, TOPS and les représentations graphiques qui y sont associées sont des marques de commerce de Bombardier Inc. ROTAX, 4-TEC, RFI et les représentations graphiques qui y sont associées sont des marques de commerce de Bombardier-Rotax GmbH &amp; Co KG, utilisées sous licence. GTX est une marque de commerce enregistrée de Castrol Ltée, utilisée sous licence.</p> <p>© &amp; © 2000-2002 Bombardier Inc. All rights reserved/ tous droits réservés.</p>	F18A05Y
F00A28Y	

## Label 15

<p><b>CAUTION</b></p> <p><b>Recommended: Premium unleaded gasoline 91 pump octane or higher.</b></p> <p><b>Minimum: Regular unleaded gasoline 87 pump octane or higher.</b></p> <p><b>ATTENTION</b></p> <p><b>Recommandé: Essence super sans plomb 91 octane ou plus.</b></p> <p><b>Minimum requis: Essence ordinaire sans plomb 87 octane.</b></p>
F18L31Y

TYPICAL

# IDENTIFICATION NUMBERS

The main components of the watercraft (engine and hull) are identified by different serial numbers. It may sometimes become necessary to locate these numbers for warranty purposes or to trace the watercraft in the event of theft.

## Hull

The Hull Identification Number (H.I.N.) is located on footboard at the rear of watercraft.

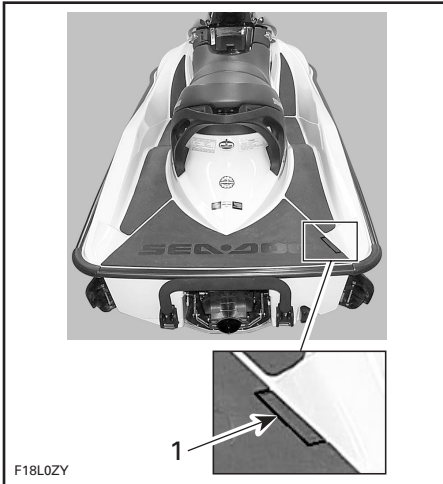

1. Hull Identification Number (H.I.N.)

It is composed of 12 digits:

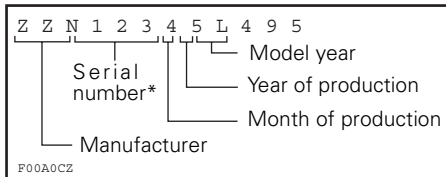

\* A letter may also be used as a digit

## Engine

**NOTE:** Refer to SPECIFICATIONS section to find what engine is used on each model. The Engine Identification Number (E.I.N.) is located on the front end of the engine.



**TYPICAL**

1. Engine Identification Number (E.I.N.)

# CONTROLS, COMPONENTS AND INSTRUMENTS LOCATION

NOTE: Some components do not apply or are optional on some models.

## GTX 4-TEC Series

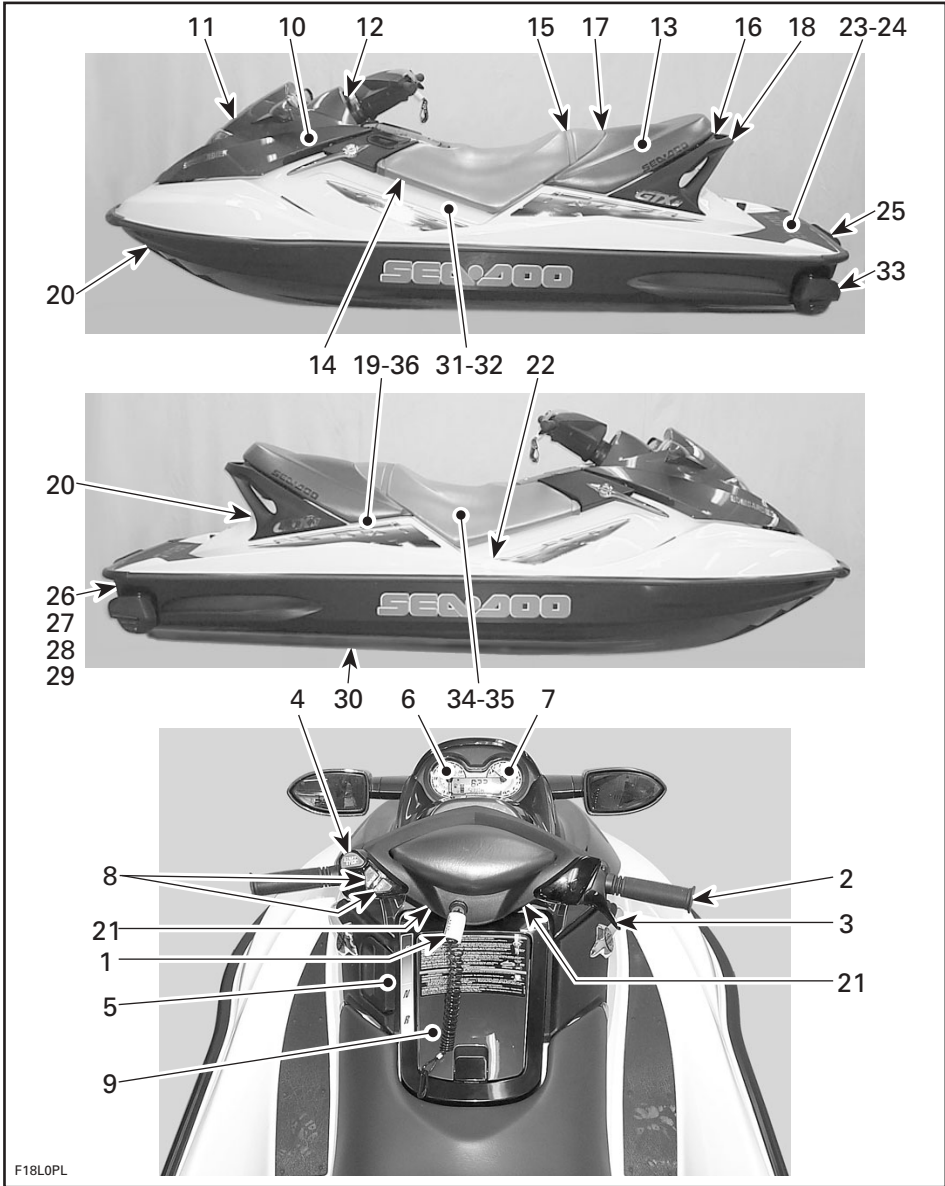

F18L0PL

TYPICAL

1. Safety Lanyard  
(engine cut-off cord)
2. Handlebar
3. Throttle Lever
4. Engine Start/Stop Button
5. Shift Lever
6. Speedometer
7. Tachometer
8. Information center gauge/buttons
9. Glove Box
10. Fuel Tank Cap
11. Front storage compartment cover
12. Front storage compartment cover latch
13. Tool Kit
14. Air Intake Opening
15. Seat Strap
16. Seat Extension Latch
17. Seat Latch
18. Rear Grab Handle
19. Rear Storage Basket
20. Front and Rear  
(bow/stern) Eyelets
21. Mooring Cleats
22. Footboard
23. Boarding Pads
24. Boarding Platform
25. Boarding Step
26. Flushing Connector
27. Bilge Drain Plugs
28. Jet Pump Nozzle
29. Reverse Gate
30. Jet Pump Water Intake
31. Fuses
32. Battery
33. Side Vanes
34. Engine Oil Dipstick
35. Engine Oil Filling Cap
36. Cooling System Expansion Tank Cap

# CONTROLS, COMPONENTS AND INSTRUMENTS FUNCTIONS

## 1) Safety Lanyard (engine cut-off cord)

THE SAFETY LANYARD CAP SHOULD BE SECURELY SNAPPED ONTO ITS POST TO BE FULLY OPERATIONAL.

Pulling the safety lanyard cap from its POST stops the engine operation.

### WARNING

While engine can be stopped using the engine start/stop button, good habits recommend that the safety lanyard also be disconnected when stopping.

Attach the safety lanyard to the operator's Personal Flotation Device (PFD) and snap the cap to the POST to be able to start the engine. Two short beeps indicates the system is ready to allow engine starting. Otherwise, refer to the TROUBLESHOOTING section for the coded signals chart.

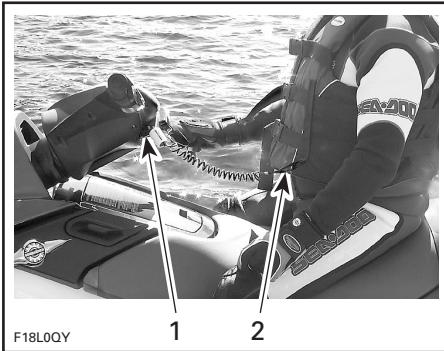

1. Safety lanyard cap on the post
2. Safety lanyard secured on operator's PFD

### WARNING

Should the engine be stopped, watercraft directional control is reduced. Always disconnect safety lanyard when watercraft is not in operation in order to prevent accidental engine starting or to avoid unauthorized use by children or others or theft.

If engine is not started within 5 seconds after installing the safety lanyard on its post, 4 very short beeps every 3 second interval will sound for approximately 4 hours to remind you to start the engine or to remove safety lanyard. Afterwards, the beeps will stop. The same will occur when safety lanyard is left on its post 5 seconds after engine is stopped.

Always ensure safety lanyard is not left on its post after engine is stopped.

**IMPORTANT:** Leaving the safety lanyard on its post when engine is not running will slowly discharge the battery.

## Digitally Encoded Security System (DESS)

The safety lanyard cap specifically contains an electronic circuit that gives it a unique electronic serial number. This is the equivalent of a conventional key.

This safety lanyard cannot be used on another watercraft and conversely, the one from another watercraft cannot be used on your watercraft.

However, the DESS brings a great flexibility. You can buy an additional safety lanyard and have it programmed for your watercraft.

To have additional safety lanyard, refer to an authorized Sea-Doo dealer.



## Limited-Speed Operation

The 4-TEC models also offers a special safety lanyard — the SEA-DOO Learning Key™ — which electronically limits the speed of the watercraft to approximately 55 km/h (35 MPH) therefore enabling first time users and less experienced operators to learn how to operate the watercraft while gaining the necessary confidence and control.



## 2) Handlebar

The handlebar controls the direction of the watercraft. Turning the handlebar to the right steers the watercraft to the right and inversely.

### **WARNING**

Check handlebar and corresponding steering nozzle and side vanes operation before starting. Never turn handlebar while someone is nearby rear of watercraft. Keep away from steering moving parts (nozzle, side vanes, linkage etc.)

## Adjustment (if so equipped)

The handlebar height can be adjusted to suit rider preferences.

To perform this adjustment, turn the knob underneath the handlebar.

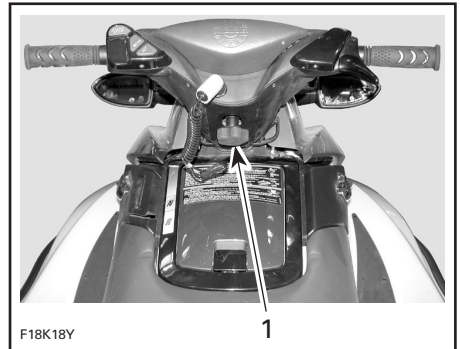

### TYPICAL

1. Adjustment knob

## 3) Throttle Lever

When the throttle lever is squeezed, the watercraft accelerates. When fully released, engine automatically slows down to idle speed and watercraft is gradually **stopped** by water drag.

#### 4) Engine Start/Stop Button

To start engine, depress and hold the start/stop button. Release immediately after engine is started.

To stop engine, depress the start/stop button. When stopped, disconnect safety lanyard from the POST. It is suggested to release throttle lever first.

#### WARNING

Directional control is reduced when the throttle is released or when engine is off.

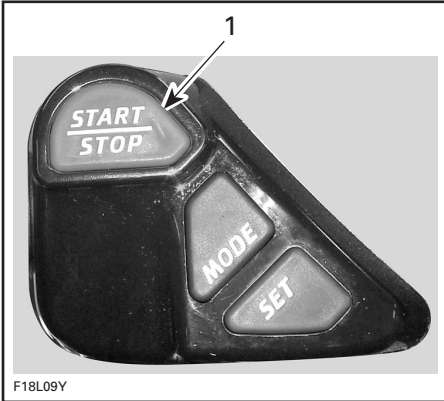

1. Engine start/stop button

#### 5) Shift Lever

A push-pull lever:

- forward
- neutral
- reverse.

#### WARNING

Shift lever should only be used when the engine is idling and craft is completely stopped. Do not use as a grab handle.

#### WARNING

Only use reverse at slow speed and for the shortest time possible. Always ensure the path behind is clear of objects and persons including children playing in shallow water.

**CAUTION:** Never rev the engine at high RPM in reverse.

From the forward position, pull the lever to reverse. Push back to go to forward. Always set in forward when finished. To find the neutral, set in reverse then push back until the watercraft stops moving backwards.

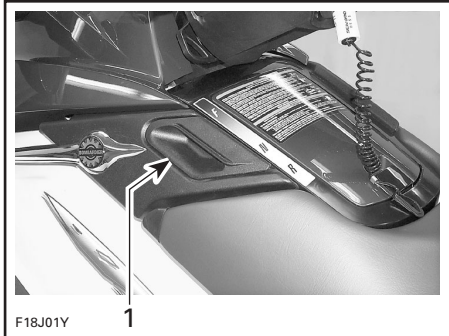

1. Forward position

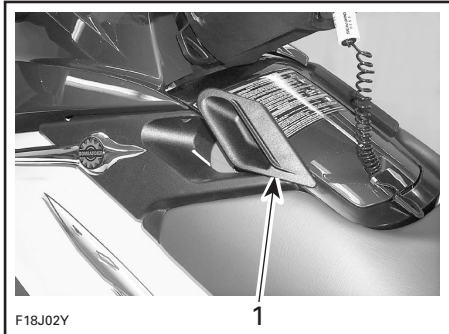

1. Neutral position

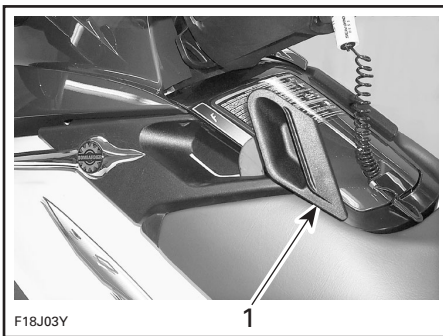

1. Reverse position

## 6) Speedometer

Analog speedometer indicates the speed of watercraft in miles per hour (MPH) and kilometers per hour (km/h).

In addition, a digital speedometer can be displayed in the information center. See INFORMATION CENTER GAUGE/ BUTTONS below. The speed sensor mounted on the transom sends the signal to the MPEM and the MPEM send it to the gauge.

## 7) Tachometer

An analog tachometer indicates the revolutions per minute (RPM) of the engine. Multiply by 1000 to obtain the actual revolutions. In addition, a digital tachometer can be displayed in the information center. See INFORMATION CENTER GAUGE/ BUTTONS below.

## 8) Information Center Gauge/Buttons

This is a multifunction gauge that supplies several real time useful information to the driver.

## Components Description

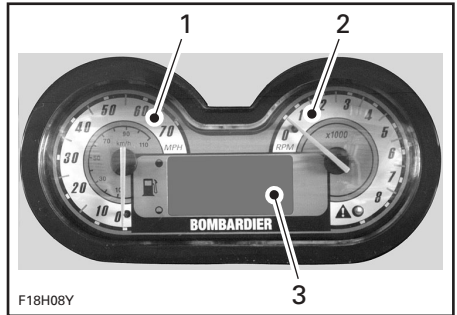

1. Analog speedometer
2. Analog tachometer
3. Display area

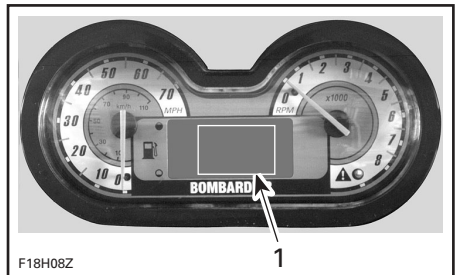

1. Text and numerical area

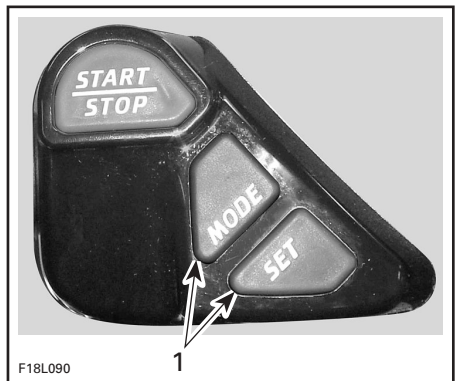

1. Function buttons

## Display Area

The display area comprises the following.

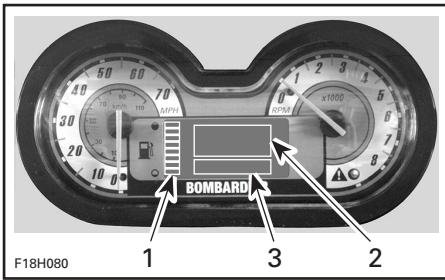

1. Fuel level indicator
2. Numerical section
3. Units and messages section

## Fuel Level Display

Bar gauge continuously indicates the amount of fuel in the fuel tank while riding. A low-fuel condition is also indicated when in the information center when only one bar is displayed. See MESSAGE DISPLAY below.

## Numerical Section

This section shows the digits of the function displayed such as the speedometer, trip hour meter etc.

## Units and Messages Section

This section shows the units related to the numbers displayed. Units such as KMH (MPH), HOUR etc. are displayed.

This section also display navigationa and system fault informations.

See the gauge functions and message lists below for more details.

## Gauge Functions

**DIGITAL TACHOMETER:** INDICATES THE REVOLUTION PER MINUTE (RPM) OF THE ENGINE.

**Digital Speedometer:** Indicates the speed of the watercraft in miles per hour (MPH) and kilometer per hour (km/h).

**Depth Gauge (if so equipped):** It continuously display the water depth under the hull within 0 to 150 meters (0 to 500 feet).

## WARNING

Never use the depth gauge as a warning device to ride in shallow water. Use it as a navigation guide only. Not to be used for navigation purposes.

**Compass:** Displays the cardinal points to indicate the orientation of the watercraft.

## WARNING

Use the compass as a guide only. Not to be used for navigation purposes.

**Average Speed:** The information center approximately calculates and displays the average speed (AV KM/H or AV MPH) of the watercraft since the last engine start.

**Distance (KM or MILES).** The information center approximately calculates the distance based on the operation time and the watercraft speed and displays the result in kilometers (KM) or miles (MILES).

**Hourmeter:** Displays the time in hours of the watercraft usage (HOUR).

**Water Temperature:** Displays the water temperature of the water surface (L TEMP) in degrees Celsius (°C) or Fahrenheit (°F).

**Exterior Temperature:** Displays the exterior air temperature (E TEMP) in degrees Celsius (°C) or Fahrenheit (°F).

**Trip Hour Meter: (TRIPMTR)** Allows to measure an interval of time in hours and minutes (hh:mm).

## Function Buttons

Different displays and functions can be activated using 2 buttons — MODE and SET — following specific sequences as described below.

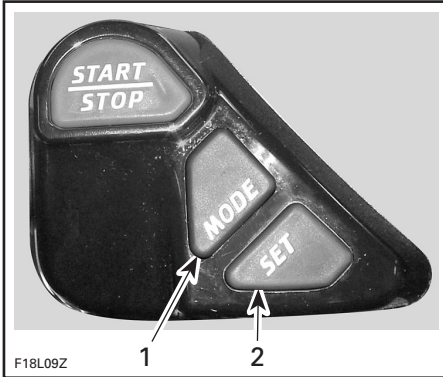

1. To change display mode
2. To set or reset a function

### Resetting a Function

TO RESET A FUNCTION (SUCH AS THE TRIP HOUR METER, DISTANCE, ETC.) PRESS AND HOLD THE SET BUTTON FOR 2 SECONDS WHILE IN THE APPROPRIATE MODE.

### Display Selection

Repeatedly pressing the MODE button scrolls the following displays: Compass, tachometer, speedometer, average speed, distance, hourmeter, water temperature, exterior temperature, depth gauge (if so equipped), and trip hour meter.

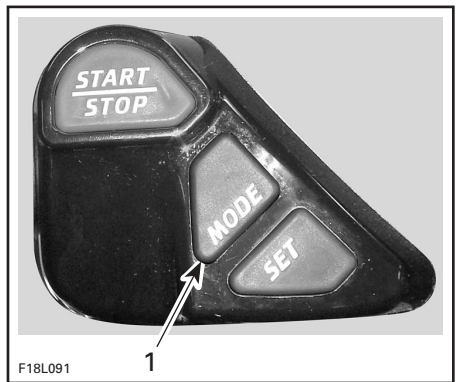

1. Press to change display mode

When you are satisfied with your choice, stop pressing the button and it will become active. The display you have chosen will remain until it is changed.

### Display Priorities

As a self test at start-up, the needles of the speedometer and tachometer will sweep to their maximum position, all LCD segments and the LED will turn on for 3 seconds each time the information center is activated (when safety lanyard is installed). This allows the driver to validate they are all working properly.

When the information center is activated, the last function set will be displayed.

In the event of a warning message, the message will blink and override the units display unless MODE button is pressed. The display will then display the last function after 10 seconds.

If more than one warning message occurs, the blinking messages will scroll every 4 seconds.

### Other Functions

The following describes how to select other available functions.

## Language Option

While in the compass mode:

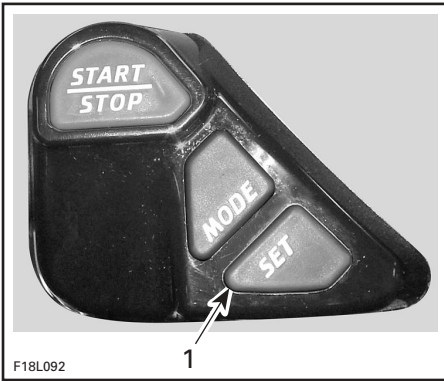

1. Press and hold for 2 seconds

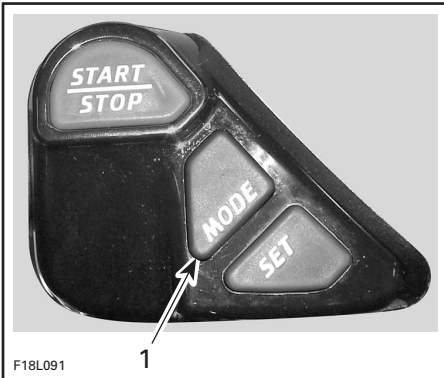

1. Repeatedly press

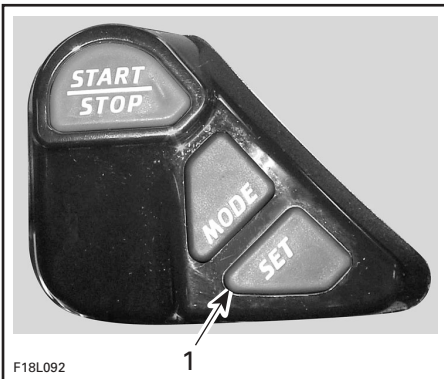

1. Press to end

## English/Metric System

Allows to display the units in the metric system or in the SAE English system.

**NOTE:** THIS FUNCTION IS NOT AVAILABLE WHEN INFORMATION CENTER DISPLAYS THE COMPASS, HOURMETER OR TRIP HOUR METER.

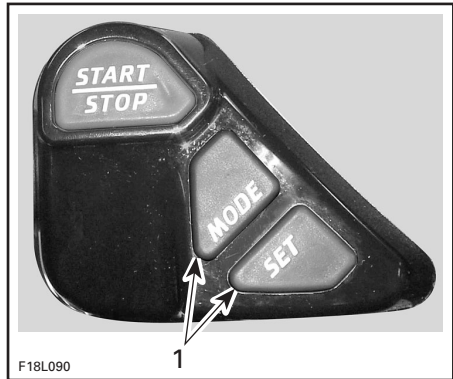

1. Press TOGETHER and hold for 2 seconds

## Trip Hour Meter

While in the trip hour meter mode:

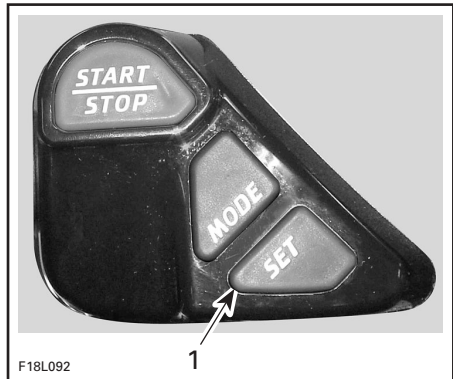

1. Press to start or stop trip hour meter

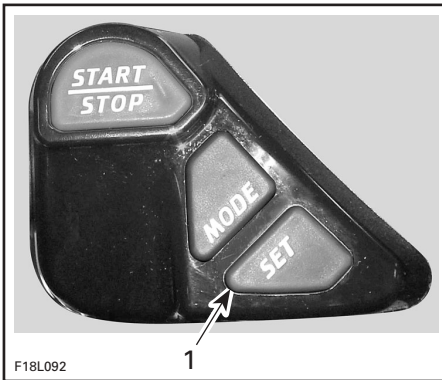

1. Press and hold for 2 seconds to reset

Trip hour meter is reset every time engine is turned off.

## Message Display

The information center features a display area that blinks a message whenever one of the following circumstances occurs. The abbreviations between parenthesis here are the code displayed:

- Engine or exhaust system overheating (H-TEMP)
- Low oil pressure (OIL)
- Low battery voltage (12 V LOW)
- High battery voltage (12 V HI)
- Low fuel level (FUEL-LO)
- Maintenance reminder (MAINT)
- Check engine (CHK ENG)
- Sensor failure (vehicle electronic equipment) (SENSOR)
- Invalid safety lanyard (KEY)
- Safety lanyard, learning key active (L KEY)
- End of faults (END).

A beeper will sound depending on the fault occurring to catch the driver attention when necessary.

Except for low liquid levels, which can be corrected by refilling, it is recommended to see an authorized Sea-Doo dealer when other messages occur.

**NOTE:** If a fault occurs, this system generates numbered fault codes (P-XXXX) that can be displayed through the information center using a special procedure. In case of a failure, you may call your authorized Sea-Doo dealer and he would be able to assist you to have the codes displayed to help troubleshooting.

## Warning Light

The red warning LED (Light-Emitting Diode) blinks along with the beeper to catch your attention.

## Maintenance Information

When the watercraft is due for a maintenance inspection, the message MAINT will blink. Afterwards, it will blink at every start-up for 10 seconds. After servicing, your authorized Sea-Doo dealer will clear it.

## 9) Glove Box

A small, convenient storage compartment for personal articles.

## 10) Fuel Tank Cap

Open the front storage compartment cover to expose fuel tank cap.

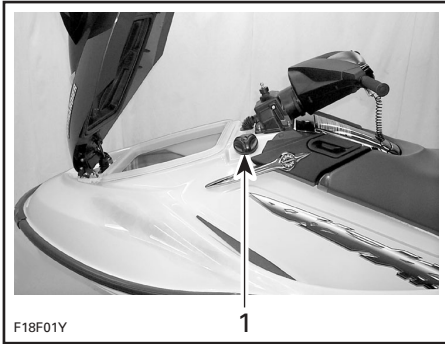

### 1. Fuel tank cap

Refer to the vehicle illustration for fuel tank cap location.

Unscrew the cap counterclockwise. After fueling, reinstall cap and fully tighten.

## WARNING

Always stop the engine before refueling. Fuel is inflammable and explosive under certain conditions. Always work in a well ventilated area. Do not smoke or allow open flames or sparks in the vicinity. Fuel tank may be pressurized, turn cap slowly when opening. Never use an open flame to check fuel level. When fueling, keep watercraft level. Do not overfill or top off the fuel tank and leave watercraft in the sun. As temperature increases, fuel expands and might overflow. Always wipe off any fuel spillage from the watercraft. Periodically verify fuel system. Always turn the fuel tank valve (**if so equipped**) to OFF position when the watercraft is not in use.

## 11) Front Storage Compartment Cover

It gives access to the front storage compartment. Always relatch cover after closing.

### Front Storage Compartment

A convenient watertight area to carry personal articles. Ideal location for towrope, first aid kit, etc.

## WARNING

Never leave any heavy or breakable objects loose in the storage area. Never operate the watercraft with any storage compartment cover open.



If there is water in the storage area, pull out the drain plug to let water go out. Reinstall the plug when done.



1. Drain plug

**NOTE:** The water will flow to the bilge. If there is an important quantity of water, ensure to drain the bilge (out of water) prior to using the watercraft.

THE FRONT STORAGE AREA INCLUDES A LATCH to hold an approved fire extinguisher (sold separately).

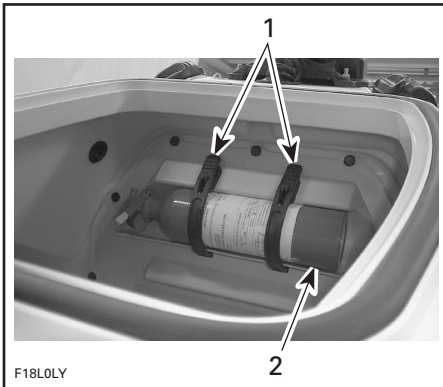

1. Retaining straps  
2. Extinguisher (sold separately)

## **WARNING**

Ensure to properly secure extinguisher with the supplied retaining straps.

Some models feature a removable basket. It's handle is convenient to carry personal objects.

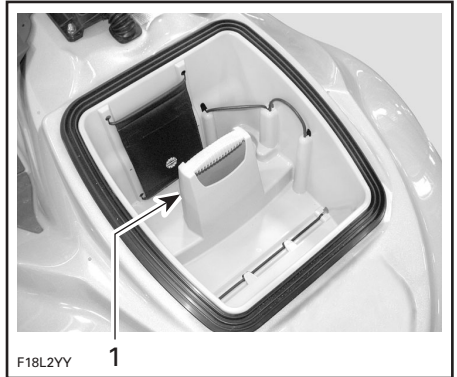

### **TYPICAL**

1. Removable basket

Some models may have convenient rubber bands and other useful accessories.

## **12) Front Storage Compartment Cover Latch**

Pull the latch lever upward in order to open the front storage compartment cover. Always relatch.

**NOTE:** Verify periodically the lock pin tightness of storage cover. Tighten if needed and make sure storage cover latches properly.

### 13) Tool Kit

LOCATED UNDER THE SEAT EXTENSION, IT CONTAINS TOOLS NEEDED TO PERFORM BASIC WATERCRAFT MAINTENANCE.

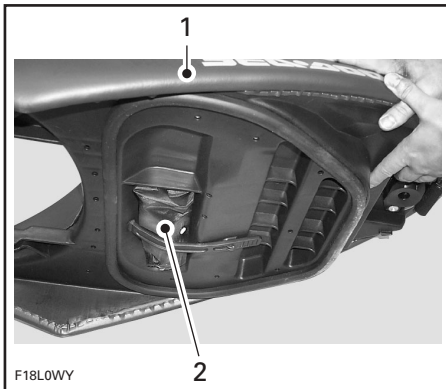

1. Seat extension
2. Tool kit

### 14) Air Intake Opening

This is where air enters to supply the engine and to ventilate the engine compartment. If the air intake opening is kept under water, water will get inside bilge.

**CAUTION:** If the air intake opening is kept under water, such as turning constantly in tight circles, water will get inside bilge, which may cause severe damage to internal parts of the engine.

### 15) Seat Strap

The seat strap provides a handhold to assist boarding and is used as a handhold for the passenger.

### 16) Seat Extension Latch

Removing the seat extension allows access to the rear storage basket. It also gives access to the seat latch.

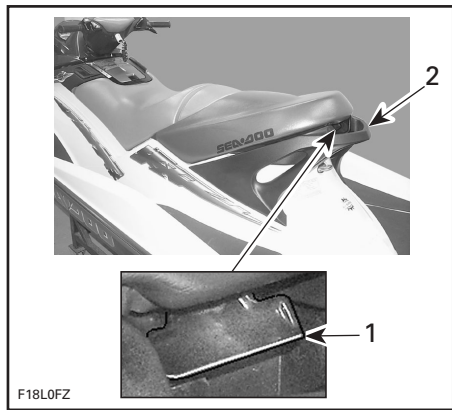

1. Seat extension latch
2. Rear grab handle

### 17) Seat Latch

REMOVING THE SEAT ALLOWS ACCESS TO THE ENGINE COMPARTMENT.

The seat latch is located at the rear end and underneath the seat.

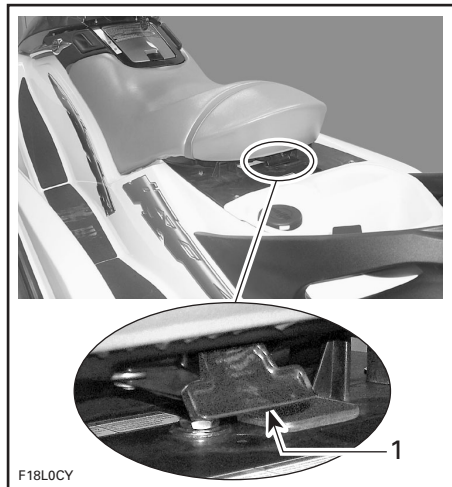

1. Seat latch

To remove seat, pull the latch lever upward and hold. Lift and pull the seat rearward.

**NOTE:** It is necessary to remove the seat extension first and repeat the same procedure to remove the seat.

## Engine Compartment

This is where the mechanical, electrical and fuel/oil systems are located.

### WARNING

Certain components in the engine compartment may be very hot. Direct contact may result in skin burn. When starting or operating the engine, do not touch any electrical part. Never leave any object, rag, tool, etc., in the engine compartment or in the bilge.

To latch seat, align latch hole with pin then, firmly push downward on rear of the seat.

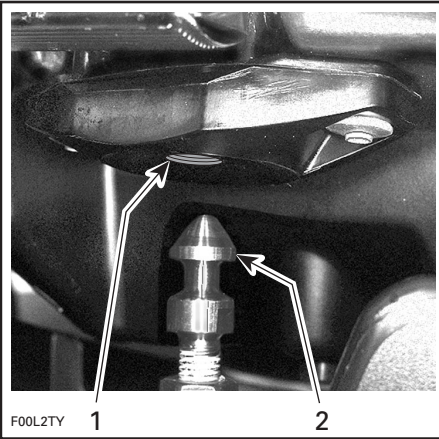

1. Latch hole
2. Pin

## 18) Rear Grab Handle

Provides a handhold for boarding when needed and a handhold for the passenger or the spotter. See illustration above.

**CAUTION:** Never use the grab handle to tow anything or to lift the watercraft.

## 19) Rear Storage Basket

A convenient watertight, removable basket to carry personal articles.

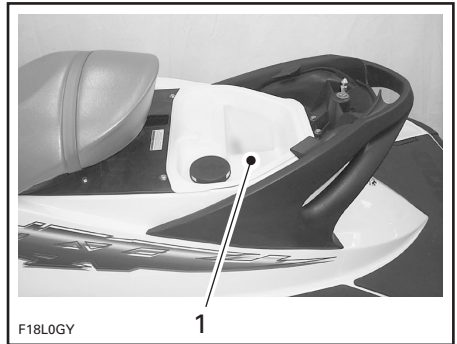

1. Rear storage basket

### Spare Spark Plug Holder

The storage basket features a spare spark plug holder.

To keep spare spark plugs dry and prevent shocks that might affect the adjustment or break them, a holder is provided.

Unscrew cap counterclockwise to expose the holder and insert spark plug in their holes. Reinstall cap.

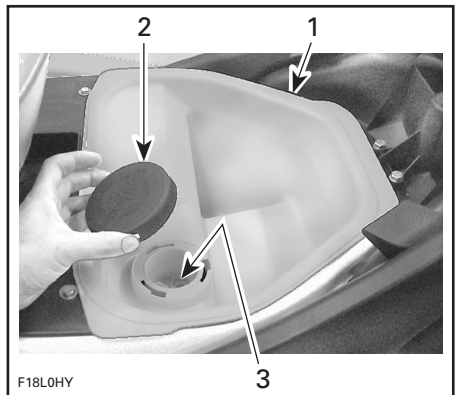

1. Storage basket
2. Spare spark plug holder cap
3. Spark plug holder

**NOTE:** Adjust spare spark plug gap according to SPECIFICATIONS before installation.

**NOTE:** Spare spark plugs are not supplied with the watercraft.

## 20) Front and Rear (bow/stern) Eyelets

### Front (bow) Eyelet

Eyelets can be used for mooring, towing and as a tie-down point during trailering.

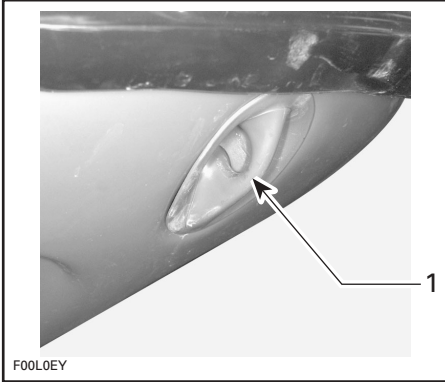

1. Front (bow) eyelet

### Rear (stern) Eyelet

This eyelet allows a rope with a hook, a closed end or an open end to be attached.

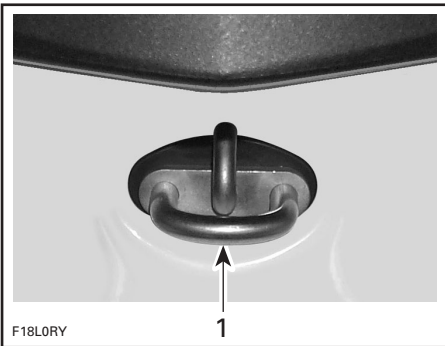

1. Rear (stern) eyelet

## 21) Mooring Cleats

These cleats can be temporarily used for docking, while refueling for example.

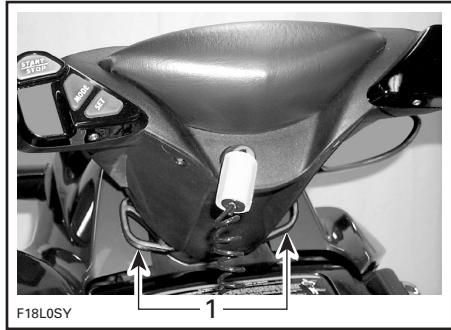

1. Mooring cleats

**CAUTION:** NEVER USE MOORING CLEATS TO PULL OR LIFT THE WATERCRAFT.

## 22) Footboard

USER'S FEET SHOULD REST ON THE FOOTBOARD WHEN RIDING.

## 23) Boarding Pads

Provide a cushioned surface for the knees when boarding from rear of watercraft.

## 24) Boarding Platform

Provides a large surface for easier boarding from rear of watercraft.

## 25) Boarding Step

A convenient step to help reboarding the watercraft.

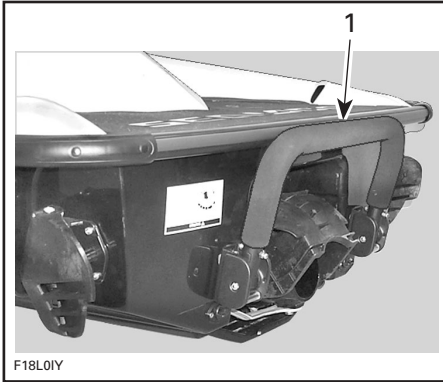

### 1. Boarding step

Pull down the step with your hand and hold until a foot or a knee is put on the step.

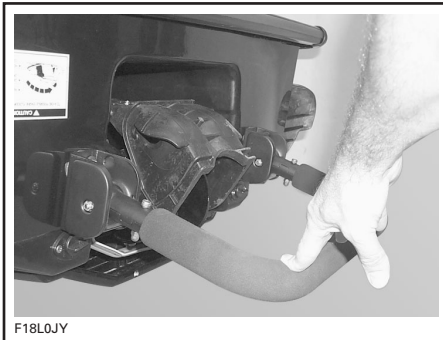

## 26) Flushing Connector

A convenient connector is provided to allow easy installation of a garden hose to flush the exhaust cooling system.

### **WARNING**

When operating the engine while the watercraft is out of the water, the heat exchanger in the ride plate may become very hot. Avoid any contact with ride plate as burns may occur.

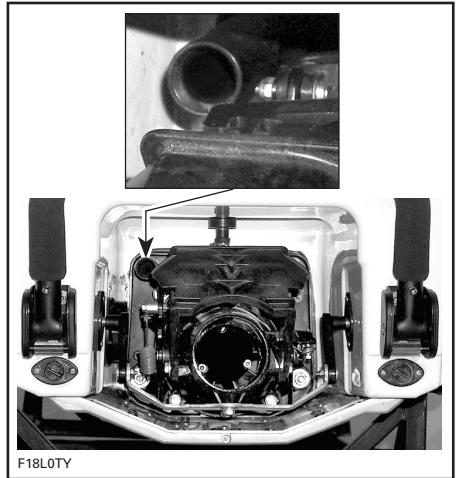

On some models, an additional flushing connector is located in engine compartment to allow flushing while watercraft is on a lift or if you prefer to flush from this location, either flushing connector can be used to flush the exhaust cooling system. Remove seat to gain access.

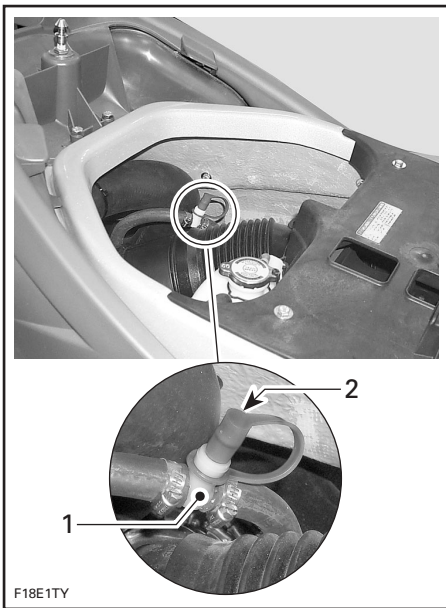

F18E1TY

1. Flushing connector
2. Dust cap

Refer to POST-OPERATION CARE section for proper use.

## 27) Bilge Drain Plugs

Should water be found in the bilge, it can be easily drained by unscrewing the drain plugs when engine is off and watercraft is out of water.

**CAUTION:** Remove boat from water prior to unscrewing drain plugs.

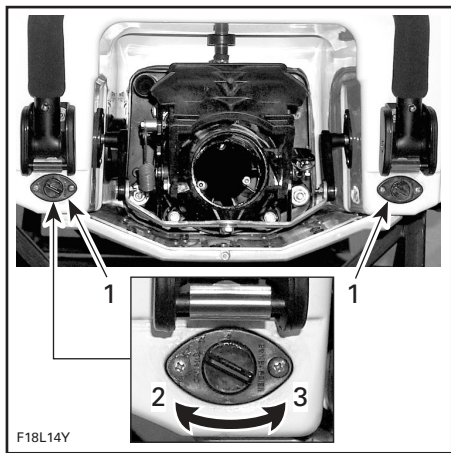

F18L14Y

### TYPICAL

1. Drain plugs
2. Tighten
3. Unscrew

Tilt the watercraft slightly to the rear so that the water can completely flow out of the bilge.

It is suggested to drain bilge on a ramp.

**CAUTION:** Make sure drain plugs are properly secured prior to launching the watercraft in water.

## 28) Jet Pump Nozzle

Jet pump nozzle turns side to side via rider input at the handlebar. This provides directional control when engine is running.

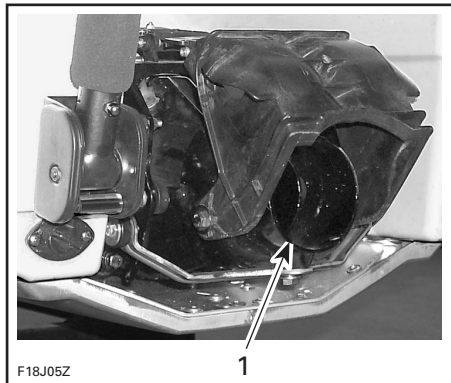

F18J05Z

1. Jet pump nozzle

## 29) Reverse Gate

When selecting the neutral or reverse position with the shift lever, the reverse gate moves up or down to obtain the desired position.

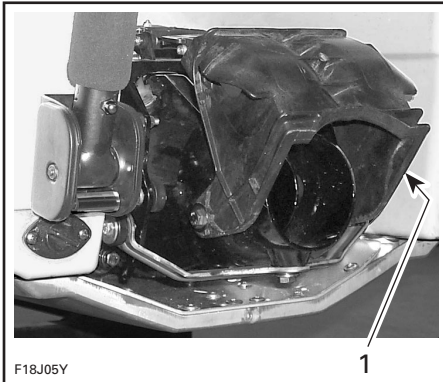

TYPICAL

1. Reverse gate

## 30) Jet Pump Water Intake and Ride Plate

The water is drawn up by the impeller through this opening. The water intake grate minimizes the entry of foreign objects into the propulsion system.

**NOTE:** The ride plate is the heat exchanger for the ENGINE cooling system.

### WARNING

Keep away from intake grate while engine is on. Items such as long hair, loose clothing or personal flotation device straps can become entangled in moving parts resulting in severe injury or drowning.

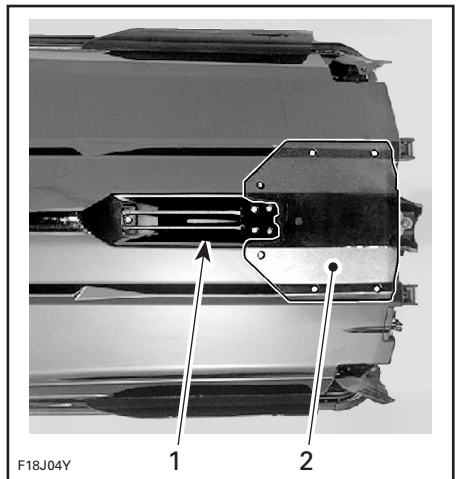

1. Water intake
2. Ride plate

### WARNING

When operating the engine while the watercraft is out of the water, the heat exchanger in the ride plate may become very hot. Avoid any contact with ride plate as burns may occur.

### 31) Fuses

Fuses are located under seat in bilge. Refer to MAINTENANCE for more details.

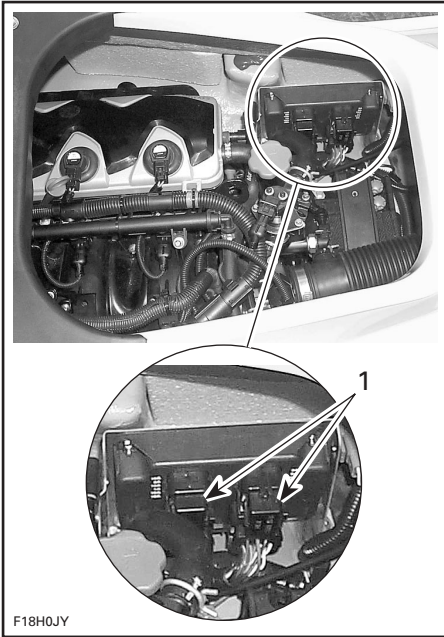

TYPICAL

1. Fuses

### 32) Battery

Battery is located under seat in bilge. Refer to SPECIAL PROCEDURES.

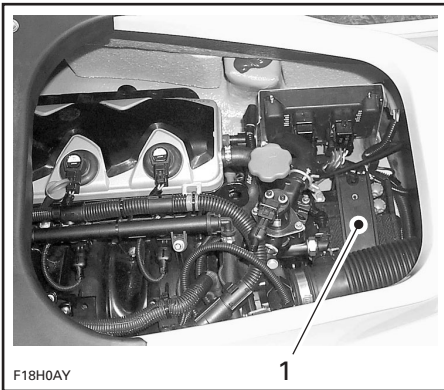

TYPICAL

1. Battery

### 33) Side Vanes

Side vanes are part of the Off-Power Assisted Steering (O.P.A.S.™) system. When engine RPM is reduced, the side vanes are lowered to assist the steering system. Refer to PRINCIPLE OF OPERATION in OPERATING INSTRUCTIONS section for the description of the system.

#### WARNING

Check handlebar and corresponding side vanes operation before starting. Never use side vanes as a supporting point to board the watercraft or to lift it. Never turn handlebar while someone is nearby rear of watercraft. Keep away from steering moving parts (nozzle, side vanes, linkage etc.).

### 34) Engine Oil Dipstick

LOCATED IN ENGINE COMPARTMENT, ON THE ENGINE. IT INDICATES THE ENGINE OIL LEVEL.

#### WARNING

Certain components in the engine compartment may be very hot. Direct contact may result in skin burn.



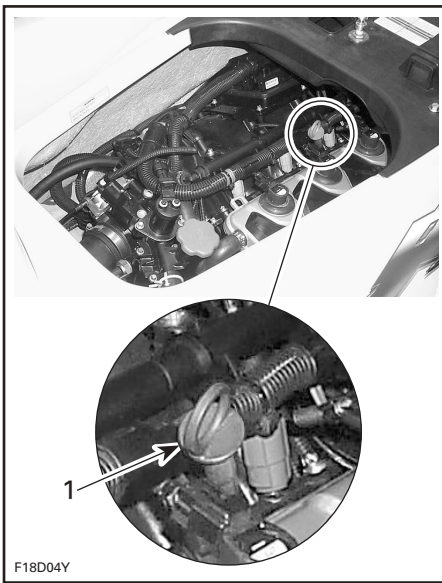

*TYPICAL*

1. Oil dipstick

Refer to LIQUIDS for more details.

### **35) Engine Oil Filling Cap**

Located in engine compartment, on the engine. It allows adding oil in the engine when required.

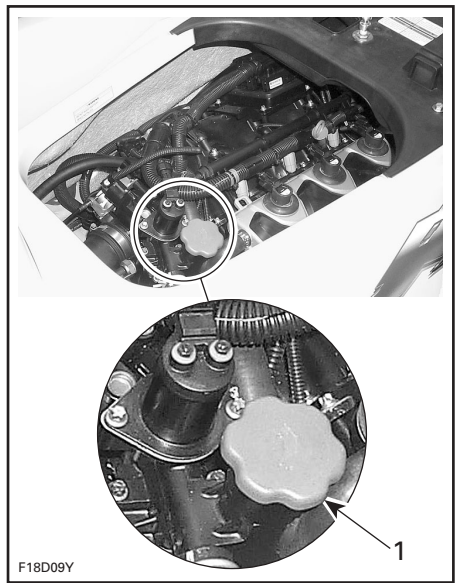

*TYPICAL*

1. Oil filling cap

Refer to LIQUIDS for more details.

### **36) Cooling System Expansion Tank Cap**

Located in engine compartment. It provides access to the expansion tank filling neck.

## **⚠ WARNING**

Certain components in the engine compartment may be very hot. Direct contact may result in skin burn.

Remove seat extension and storage basket to expose expansion tank.

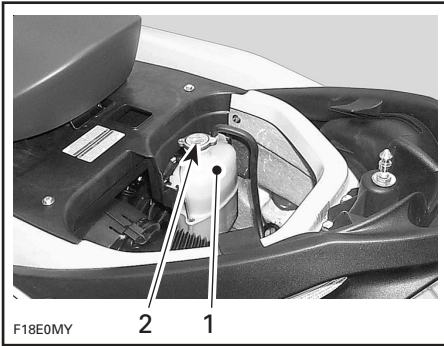

1. Expansion tank
2. Cap

Refer to LIQUIDS for more details.

### Ski/Wake Board Post (if so equipped)

Pull up the post to allow hooking a ski or wake board rope. Push down when finished and properly relock.

To lift post, unlock by pulling the locking pin then lift post. Ensure it is properly locked. Lowering the post is the opposite operation.

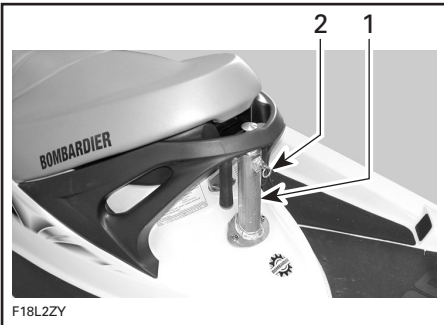

1. Ski/wake board post
2. Pull locking device to unlock

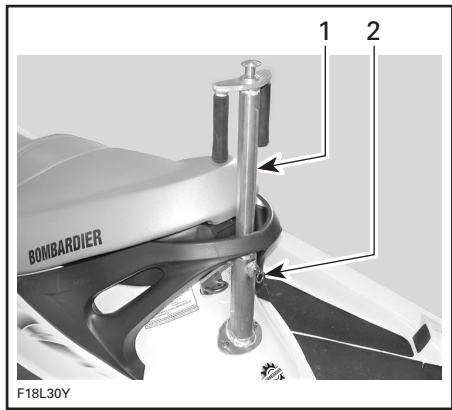

1. Ski/wake board post lifted
2. Ensure it is locked

### **WARNING**

Make sure ski/wake board post is fully extended and locked before use. Completely retract when not used. Use caution with skier/wake BOARDER IN TOW AS TOW ROPE MAY BACKLASH TO WATERCRAFT WHEN RELEASED. NEVER PERFORM A SHARP TURN WHEN TOWING A SKIER, WAKE BOARDER OR ANY TOY.

Always have one person other than the operator as an observer.

**NOTE:** THE HANDLES ARE SUPPLIED FOR THE OBSERVER TO HAVE A GRIP WHEN WATCHING.

**CAUTION:** Never use the ski/wake board post to tow other crafts.

---

## LIQUIDS

**CAUTION:** Scrupulously follow the instructions of this section. Failure to do so may reduce the engine's life and/or performance.

### Fueling Procedure

#### WARNING

Follow these safe boating fueling instructions explicitly.

Turn off engine.

Do not allow anyone to remain on the watercraft.

Tie watercraft securely to the fueling pier.

Have a fire extinguisher close at hand.

Do not insert the spout too far in filler neck.

Pour fuel slowly so that air can escape from the tank and prevent fuel flowback. Be careful not to spill fuel.

Stop filling when the fuel reaches the bottom of filler neck. Do not fill into the filler tube to prevent fuel spill out. **Do not overfill.** Fully tighten fuel tank cap.

#### WARNING

ALWAYS STOP THE ENGINE BEFORE REFUELING. FUEL IS INFLAMMABLE AND EXPLOSIVE UNDER CERTAIN CONDITIONS. ALWAYS WORK IN A WELL VENTILATED AREA. DO NOT SMOKE OR ALLOW OPEN FLAMES OR SPARKS IN THE VICINITY. FUEL TANK MAY BE PRESSURIZED. TURN CAP SLOWLY WHEN OPENING. NEVER USE AN OPEN FLAME TO CHECK FUEL LEVEL. WHEN FUELING, KEEP WATERCRAFT LEVEL. DO NOT OVERFILL OR TOP OFF THE FUEL TANK AND LEAVE WATERCRAFT IN THE SUN. AS TEMPERATURE INCREASES, FUEL EXPANDS AND MIGHT OVERFLOW. ALWAYS WIPE OFF ANY FUEL SPILLAGE FROM THE WATERCRAFT. PERIODICALLY VERIFY FUEL SYSTEM. ALWAYS TURN THE FUEL TANK VALVE (IF SO EQUIPPED) TO OFF POSITION WHEN THE WATERCRAFT IS NOT IN USE.

### Recommended Fuel

#### *Normally-Aspirated Models*

Use **regular** unleaded gasoline with 87 octane (Ron + Mon)/2 specification.

#### *Supercharged Models*

It is recommended to use a **premium** unleaded gasoline with 91 octane (Ron + Mon)/2 specification for optimum performance.

As a minimum, an **regular** unleaded gasoline with 87 octane (Ron + Mon)/2 may be used.

## All Models

**CAUTION:** Never experiment with other fuels or fuel ratios. Never use fuel containing more than 10% alcohol, (ethanol or methanol). The use of non-recommended fuel can result in watercraft performance deterioration and damage to critical parts in the fuel system and engine components.

## Engine Oil

### Recommended Oil

This watercraft features a 4-stroke engine that requires 4-stroke motor oil for internal engine lubrication. Ensure to respect the following requirements.

Use 4-stroke engine oil that meets or exceeds the requirements for API service classification SG, SH or SJ. Always check the API service label on the oil container to be sure it includes those letters. Only use high-quality high-detergent oil.

**CAUTION:** Never use any two-stroke engine oil.

### Oil Viscosity

SAE 10W40 is recommended for all seasons.

### Oil Level

**CAUTION:** CHECK LEVEL FREQUENTLY AND REFILL IF NECESSARY. DO NOT OVERFILL IT WOULD MAKE THE ENGINE SMOKE AND REDUCE ITS POWER. OPERATING THE ENGINE WITH AN IMPROPER LEVEL MAY SEVERELY DAMAGE ENGINE. WIPE OFF ANY SPILLAGE.

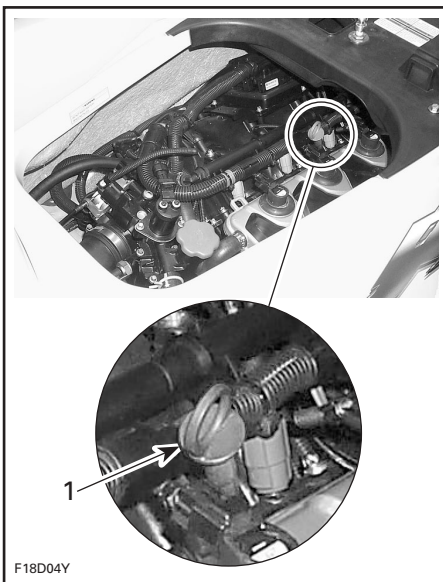

### TYPICAL

#### 1. Dipstick

Check the oil level as follows:

**NOTE:** Before checking the oil level on this engine, it is necessary to let it idle for 30 seconds **before** shutting it off. Thereafter it is necessary to wait 30 seconds. Then, the oil can be checked. This is required to allow the oil to properly level in the different oil chambers. Otherwise, you will have a false oil level reading.

1. Watercraft must be level. Check oil level either with watercraft in water or out of water. Engine should be warm.

**CAUTION:** NEVER RUN ENGINE WITHOUT SUPPLYING WATER TO THE EXHAUST COOLING SYSTEM WHEN WATERCRAFT IS OUT OF WATER.

2. If out of water, raise trailer tongue and block in position when bumper rail is level. Install a garden hose to the flushing connector. Refer to FLUSHING in POST-OPERATION CARE and follow the procedure.

**CAUTION: FAILURE TO FLUSH EXHAUST COOLING SYSTEM, WHEN ENGINE IS OUT OF WATER, MAY SEVERELY DAMAGE ENGINE AND/OR EXHAUST SYSTEM.**

3. Warm-up engine then let idle for 30 seconds before stopping.
4. Stop engine.
5. Wait at least 30 seconds THEN PULL DIPSTICK OUT AND wipe clean.

## WARNING

Engine oil may be hot. Certain components in the engine compartment may be very hot. Direct contact may result in skin burn.

**CAUTION: NEVER RUN ENGINE LONGER THAN 5 MINUTES. DRIVE LINE SEAL HAS NO COOLING WHEN WATERCRAFT IS OUT OF WATER.**

6. Reinstall dipstick, push in completely.
7. REMOVE DIPSTICK AND READ OIL LEVEL. IT SHOULD BE BETWEEN MARKS.

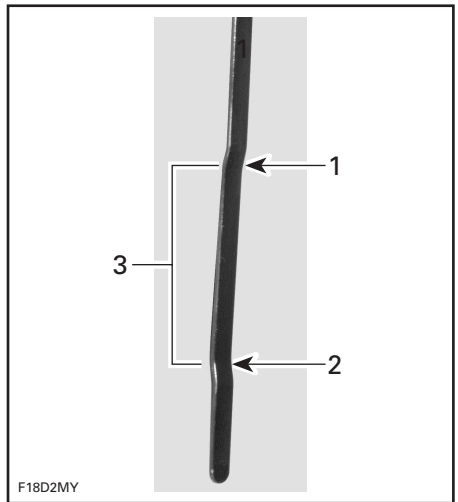

1. Full
2. Add
3. Operating range

8. Otherwise, add oil up to have the level between marks as required.
9. To add oil, unscrew oil cap. Place a funnel into the opening and add the recommended oil to the proper level. **Do not overfill.**

**NOTE:** Every time oil is added in engine, the complete procedure explained above must be done (engine restarted, idling for 30 seconds, 30 seconds waiting time and then, rechecking the oil level). This is required to allow the oil to properly transfer in the different oil chambers and to then level. Otherwise, you will have a false oil level reading.

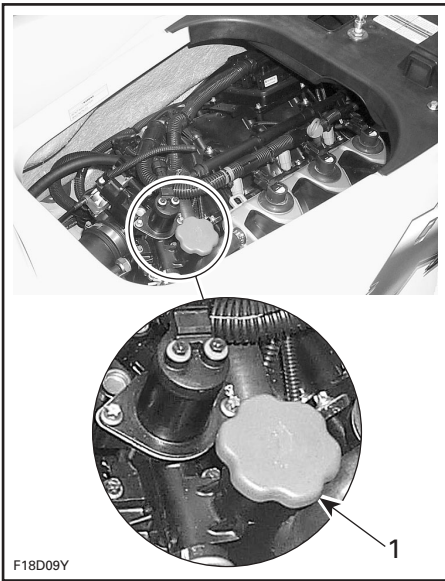

F18D09Y

**TYPICAL**

1. Oil cap

10. Properly reinstall oil cap and dipstick.

**Engine Coolant**

**Recommended Coolant**

Always use ethylene-glycol antifreeze containing corrosion inhibitors specifically for internal combustion aluminum engines.

**NOTE:** When available, it is recommended to use biodegradable antifreeze compatible with internal combustion aluminum engines. This will contribute to protect the environment.

Cooling system must be filled with water and antifreeze solution (50% water, 50% antifreeze).

Bombardier sells premixed coolant with freezing protection up to -52°C (-62°F) (P/N 293 600 038).

TO PREVENT ANTIFREEZE DETERIORATION, ALWAYS USE THE SAME BRAND. NEVER MIX DIFFERENT BRANDS UNLESS COOLING SYSTEM IS COMPLETELY FLUSHED AND REFILLED. REFER TO AN AUTHORIZED BOMBARDIER SEA-DOO DEALER.

**Coolant Level**

**⚠ WARNING**

Check coolant level with engine cold. Never add coolant in cooling system when engine is hot.

Remove seat extension to expose cooling system expansion tank.

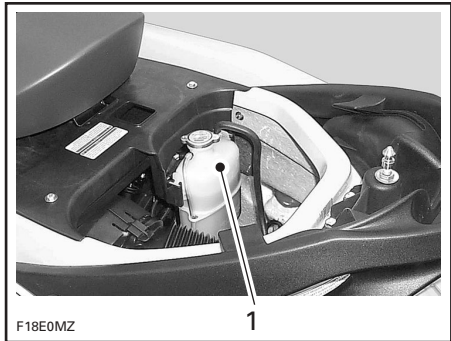

F18E0MZ

1. Expansion tank

With vehicle on a level surface, liquid should be between MIN. and MAX. level marks of coolant reservoir when engine is cold.

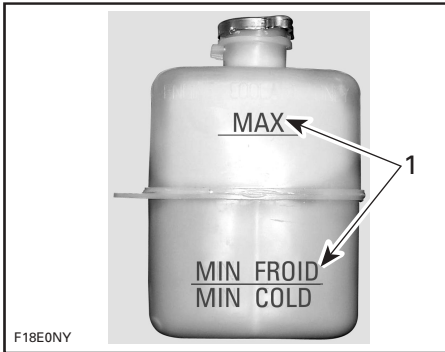

1. Level between marks when engine is cold

**NOTE:** The watercraft is level when it is in water. When on a trailer, raise trailer tongue and block in this position when bumper rail is level.

Add coolant to have the level between marks as required. Use a funnel to avoid spillage. **Do not overfill.**

Properly reinstall and tighten filler cap then reinstall seat extension.

**NOTE:** A cooling system that frequently requires coolant is the indication of leaks or engine problems. See an authorized Bombardier SEA-DOO dealer.

## Coolant Replacement

Refer to MAINTENANCE section.

---

## **BREAK-IN PERIOD**

**CAUTION:** Scrupulously follow the instructions of this section. Failure to do so may reduce the engine's life and/or performance.

With SEA-DOO watercraft powered by Rotax® engines, a break-in period of 10 hours is required before continuous operation at full throttle.

To achieve a good break-in, throttle lever should not be depressed more than 3/4, however, brief acceleration and speed variations contribute to a good break-in.

**CAUTION: CONTINUED WIDE OPEN THROTTLE RUNS AND PROLONGED CRUISING WITHOUT SPEED VARIATIONS SHOULD BE AVOIDED, THIS CAN CAUSE ENGINE DAMAGE DURING THE BREAK-IN PERIOD.**

**NOTE:** Never add oil in fuel tank during break-in period.

### **10-Hour Inspection**

It is highly recommended that after the first 10 hours of operation, the watercraft be checked by an authorized Sea-Doo dealer. This inspection will also provide the opportunity to discuss the unanswered questions you may HAVE ENCOUNTERED DURING THE FIRST HOURS of operation.

---

**The 10-hour inspection is at the expense of the watercraft owner.**

---



# PRE-OPERATION CHECKS

## WARNING

The pre-operation check is very important prior to operating the watercraft. Always check the proper operation of critical controls, safety features and mechanical components, before starting as listed hereinafter. If not done as specified here, severe injury or death might occur. Bring all safety equipment required by local laws.

Some of the following items may not have been previously covered in this guide, however they will be described in the MAINTENANCE or SPECIAL PROCEDURES section. Please refer to these sections to have more detailed information.

## WARNING

Engine should be off and the safety lanyard should always be removed from its post prior to verifying any of the following points. Only start watercraft once all items have been checked and operate properly.

ITEM	OPERATION	✓
Hull	Inspect.	
Jet pump water intake	Inspect/clean.	
Bilge	Drain. Ensure plugs are secured.	
Battery	Inspect tightness of cables and retaining fasteners.	
Fuel tank	Refill.	
Engine compartment	Check fuel line connections for tightness. Verify for any fuel leak/odor as well as oil and coolant leaks.	
Engine oil level	Check/refill.	
Engine coolant level	Check/refill.	
Steering system and side vanes	Check operation.	
Throttle system	Check operation.	
Shifter system	Check operation.	
Storage compartment covers and seat	Ensure they are closed and latched.	
Safety lanyard and engine start/stop button	Check operation.	
Water flow in exhaust manifold (only when temperature is below or close to freezing point)	Check if water properly flows in exhaust manifold.	

**NOTE:** See the detailed instructions hereinafter.

## Hull

Inspect hull for cracks or damage.

## Jet Pump Water Intake

Remove weeds, shells, debris or anything else that could restrict the flow of water and damage exhaust cooling system or propulsion unit. Clean as necessary. If any obstruction can not be removed, refer to an authorized Sea-Doo dealer for servicing.

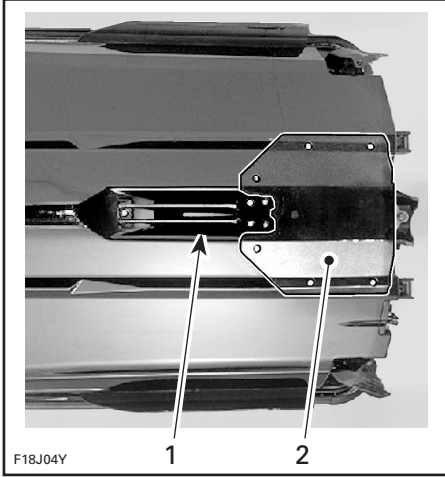

### INSPECT THESE AREAS

1. Water intake
2. Ride plate

Inspect leading edges of the impeller, if they have nicks or bends, performance will be greatly reduced.

Inspect for any possible coolant leak from ride plate.

### WARNING

When operating the engine while the watercraft is out of the water, the heat exchanger in the ride plate may become very hot. Avoid any contact with ride plate as burns may occur.

## Bilge

Should water be present in the bilge, tilt the watercraft to the rear and unscrew drain plugs to completely empty the bilge.

Secure bilge drain plugs.

### WARNING

Make sure drain plugs are properly secured prior to launching the watercraft in water.

## Battery

### WARNING

Verify tightness of battery cables to their posts and condition of battery retaining fasteners. Do not charge or boost battery while installed.

## Fuel Tank

With the watercraft horizontal, fill the fuel tank to specified level.

Check fuel tank retaining straps / fasteners.

## Engine Compartment

### WARNING

Should any leak or gasoline odor be present, do not start the engine. Refer to an authorized Sea-Doo dealer before use.

## Engine Oil Level

Ensure oil level is appropriate as specified in LIQUIDS section. Check for oil leaks on engine and in engine compartment.

## Engine Coolant Level

Ensure coolant level is appropriate as specified in LIQUIDS section. Check for coolant leaks on engine, in bilge and from ride plate.

### **WARNING**

When operating the engine while the watercraft is out of the water, the heat exchanger in the ride plate may become very hot. Avoid any contact with ride plate as burns may occur.

## Steering System

Assisted by another person, check steering operation for free movement. When the handlebar is horizontal, the jet pump nozzle should be in the straight ahead position. The rear edge of side vanes should be pointing outside of watercraft by approximately 20°. Ensure the jet pump nozzle and side vanes pivot easily and in the same direction as the handlebar.

### **WARNING**

CHECK HANDLEBAR AND CORRESPONDING STEERING NOZZLE OPERATION BEFORE STARTING. NEVER TURN HANDLEBAR WHILE SOMEONE IS NEARBY REAR OF WATERCRAFT. KEEP AWAY FROM STEERING MOVING PARTS (NOZZLE, SIDE VANES, LINKAGE ETC.).

## Throttle System

Check throttle lever for free and smooth operation. It should return to its initial position immediately after it is released.

### **WARNING**

Check throttle lever operation before starting the engine.

## Shifter System

Check reverse gate operation for free movement. With shift lever in forward position, the gate should be in upward position; and offering a resistance to go downward. With the shift lever in neutral position, gate should be in middle position. With shift lever in reverse position, gate should be in downward position.

### **WARNING**

Verify the reverse gate operation before starting the engine.

## Storage Compartment Covers and Seat

Ensure they are closed and latched.

### **WARNING**

Make sure seat is securely latched.

## Safety Lanyard and Engine Start/Stop Button

Position shift lever in neutral. Ensure that both switches operate properly. Start engine and stop it using each switch individually.

### **WARNING**

Should the safety lanyard cap is loose or fail to remain on its post, replace it immediately in order to avoid unsafe use.

## Water Flow in Exhaust Manifold (only when temperature is below or close to freezing point)

In Northern areas, if watercraft is to be used when temperature is below or close to freezing point (0°C (32°F)) or if watercraft was left unused while temperature was below or close to freezing point, water may be frozen in the supply hose going to the exhaust manifold. This could cause exhaust cooling system overheating. To ensure it is properly working, do the following prior to using the watercraft:

- The procedure is to be performed with watercraft out of water.
- Connect a garden hose to the flushing connector at jet pump.
- Perform the flushing operation as explained in POST-OPERATION CARE.
- ENSURE WATER FLOWS OUT OF JET PUMP. OTHERWISE, WATER IS FROZEN IN SUPPLY HOSE AND RESTRICTS WATER FLOW. DO NOT OPERATE THE WATERCRAFT IN THIS CONDITION.

NOTE: Pay attention that some water will also flow out of exhaust outlet. Make sure water is effectively flowing out of jet pump.

**CAUTION: OPERATING WATERCRAFT WITH FROZEN WATER IN SUPPLY HOSE MIGHT LEAD TO ENGINE COMPONENTS DAMAGE.**

NOTE: When water freezes, no damage to engine components will occur as water expands but it may cause damage by preventing full flow of cooling water.

- Either wait until ice melt or pour some hot water on supply hose going to exhaust manifold. Then, perform the flushing operation again to make sure water properly flows out of jet pump. If you need assistance, refer to an authorized Sea-Doo dealer.

### **WARNING**

DO NOT USE ANY ELECTRICAL HEATING DEVICE TO HEAT THE HOSE. ELECTRICAL DEVICES MAY GENERATE SPARKS THAT WOULD IGNITE FUEL VAPORS THAT MIGHT BE PRESENT IN THE BILGE CAUSING A FIRE OR AN EXPLOSION.

- Ensure to drain bilge if water is present.

# OPERATING INSTRUCTIONS

## **⚠ WARNING**

Always perform the PRE-OPERATION CHECKS before operating the watercraft. Become thoroughly familiar with all controls and the function of each. Should any control or instruction not be fully understood, refer to an authorized Sea-Doo dealer.

## **Principle of Operation Propulsion**

The engine is directly coupled to a drive shaft which, in turn, rotates an impeller. This impeller is accurately adjusted in a housing where the water is drawn up from underneath the watercraft. Then the water flows through the impeller to a venturi. The venturi accelerates the water and produces thrust to move the watercraft. Depressing the throttle lever increases engine speed and therefore watercraft speed.



TYPICAL

## **⚠ WARNING**

Whenever the engine is to be started, the operator and passenger(s) should always be properly sitting on the watercraft and be wearing protective clothing including a Coast GUARD APPROVED PFD AND A WET SUIT bottom.

## **⚠ WARNING**

KEEP AWAY FROM INTAKE GRATE WHILE ENGINE IS ON. ITEMS SUCH AS LONG hair, loose clothing or personal flotation device straps can become entangled in moving parts resulting in severe injury or drowning.

The shift lever should be in the forward position in order for the watercraft to advance.

## **Neutral and Reverse**

## **⚠ WARNING**

Never use jet pump components as a supporting point to board the watercraft. Shift lever should only be used when the engine is idling and watercraft is completely stopped. Never rev the engine at high RPM in reverse. Do not use reverse to stop the watercraft. Only use reverse at slow speed and for the shortest time possible. Always ensure the path behind is clear of objects and persons including children playing in shallow water.

To find the neutral, set in reverse then push back until the watercraft stops moving backwards.

The reverse gate will be in the middle position, directing half of the thrust toward the front of the watercraft to minimize watercraft movement.

**⚠ WARNING**

When the watercraft is in neutral position, the drive shaft and impeller are still turning.

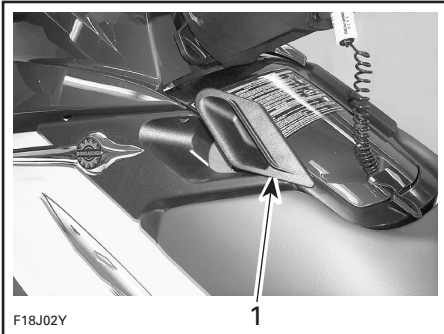

1. Shift lever in neutral position

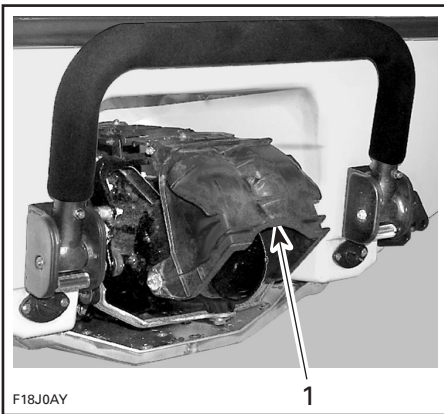

1. Reverse gate in middle position

To obtain reverse, pull shift lever completely. The reverse gate will be in downward position, directing all the thrust toward the front of the watercraft.

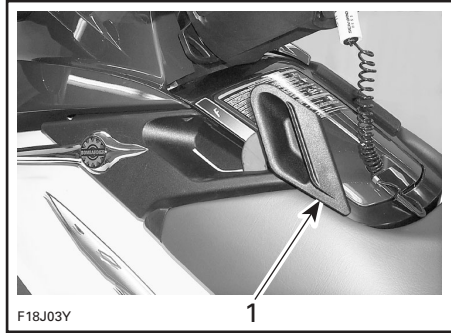

1. Shift lever in reverse position

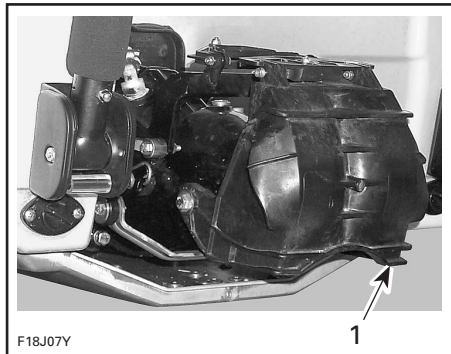

1. Reverse gate in downward position

**NOTE:** To obtain maximum efficiency and control from the reverse, increase engine speed to slightly above idle. Too much RPM will create water turbulence and reduce reverse efficiency.

In reverse position, turn the handlebar in the same direction that you want to move the rear of the watercraft.

For example, to steer the rear of the watercraft to the left side, turn the handlebar to the left side.

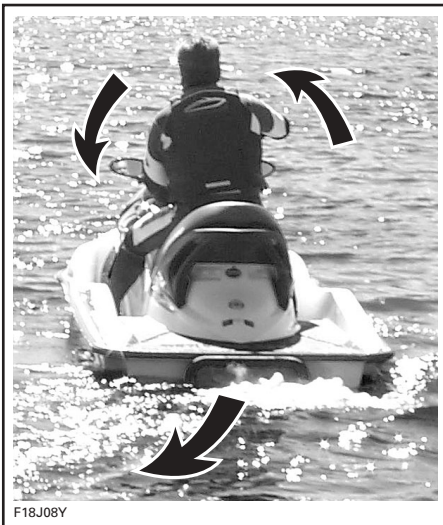

F18J08Y

### **⚠ WARNING**

Shift lever should only be used when the engine is idling and watercraft is completely stopped. Do not use reverse to stop the watercraft.

## **Steering**



F18J09Y

Turning the handlebar pivots the jet pump nozzle which controls the watercraft direction. Turning the handlebar to the right will turn the watercraft to the right and inversely. The throttle should be applied to turn the watercraft.

### **⚠ WARNING**

Throttle should be applied and handlebar turned to change the direction of the watercraft. Steering efficiency will differ depending on the number of passengers, load, water conditions and environmental factors such as the wind.

Unlike a car, a watercraft needs some throttle to turn. Practice in a safe area applying the throttle and turning away from an imaginary object. This is a good collision avoidance technique.

### **⚠ WARNING**

Directional control is reduced when the throttle is released and/or when engine is off.

THE WATERCRAFT BEHAVES DIFFERENTLY WITH A PASSENGER AND REQUIRES GREATER SKILL. THE PASSENGER SHOULD ALWAYS GRIP THE SEAT STRAP OR GRAB HANDLE. REDUCE SPEED AND AVOID SHARP TURNS. AVOID CHOPPY WATER CONDITIONS WHEN CARRYING A PASSENGER.

## **OFF-POWER ASSISTED STEERING SYSTEM (O.P.A.S.)**

The Off-Power Assisted Steering (O.P.A.S.) system uses a dual side vanes design that assists the watercraft steering in deceleration, to redirect watercraft path when steering is turned after throttle has been released or engine stopped.

The side vanes on the rear sides of the hull, turn as the steering is turned to assist the watercraft turning. At first, carefully experiment turning with this system.



1. Side vanes turn following steering movement

When engine is running at approximately 75% or more RPM, the side vanes are automatically raised to upper position since they are not required at that vehicle speed range. Between 30% and 75% engine RPM, side vanes are gradually raised from lower position to upper position.

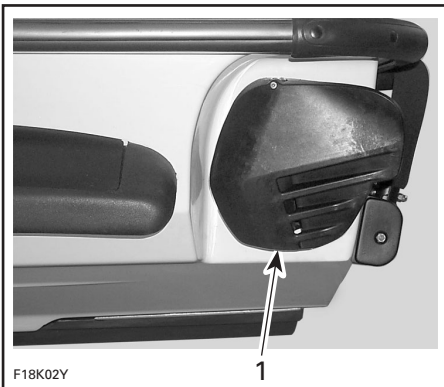

1. Side vane in upper position

When throttle is released and engine RPM drops, the side vanes are automatically lowered thus assisting steering control.

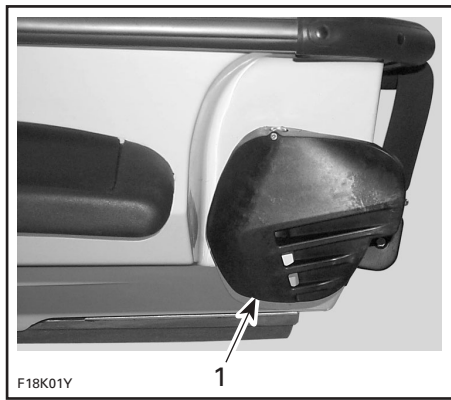

1. Side vane in lower position

## Boarding the Watercraft

### General

As with any watercraft, boarding should be done carefully and engine should not be running.

### WARNING

Engine should be OFF when boarding the watercraft or when using boarding step. Keep limbs away from jet or intake grate. Stay on center of the step. Only one person at a time on the step. Never use the step for pulling, towing, diving or jumping, boarding a watercraft that is out of water or any other purpose other than a boarding step.

Boarding is facilitated by using a step.

### WARNING

Inexperienced riders should practice how to get aboard (all methods explained here) close to shore first before venturing into deep water.



## **WARNING**

Never use jet pump components or side vanes as a supporting point to board the watercraft.

### **Boarding from a Dock or in Shallow Water**

When boarding from a dock, slowly place one foot on the watercraft footboard nearest the dock and, at the same time, transfer the body weight to the other side in order to balance the watercraft while holding the handlebar. Then, bring the other foot over the seat and put it on the other footboard. Push the watercraft away from the dock.



F18A01Y

In shallow water, board the watercraft either from the side or the rear.

Ensure there is at least 90 cm (3 ft) of water underneath the lowest rear portion of the hull.

**TAKE INTO ACCOUNT THAT THE HULL WILL LOWER IN WATER WHEN ALL PASSENGERS ARE ABOARD. BE CERTAIN TO MAINTAIN THE SPECIFIED DEPTH SO SAND, PEBBLES AND ROCKS WILL NOT BE DRAWN UP IN THE JET PUMP.**

**CAUTION:** Starting the engine or riding the watercraft in shallower water might damage the impeller or other jet pump components.



*A. Maintain at least 90 cm (3 ft) underneath the lowest rear portion of the hull when all passengers are aboard*

### **Boarding in Deep Water**

**Operator Alone**

Swim to the rear of the watercraft.

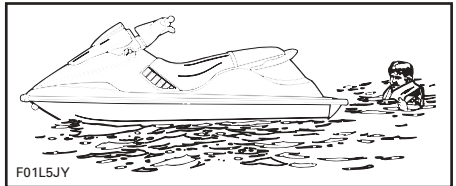

Grip the grab handle and pull yourself upward until your knee can reach the boarding platform then grip the seat strap.

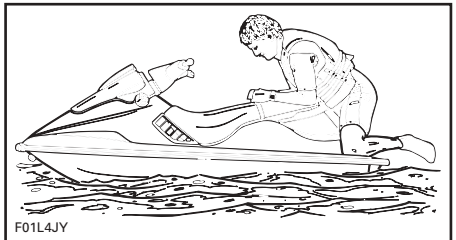

Bring your feet on the footboard while maintaining balance.

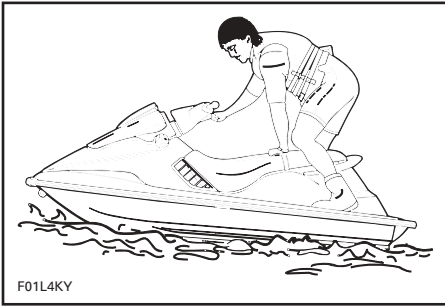

Sit astride the seat.

### Operator with a Passenger

The operator climbs on the watercraft the same way as explained previously.

In choppy water, the passenger, while in the water, may hold the watercraft to help the operator in climbing aboard.

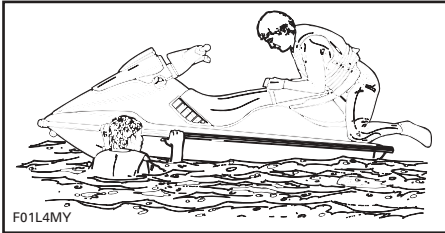

The passenger then climbs on the watercraft while the operator maintains balance by sitting as close as possible to the console.

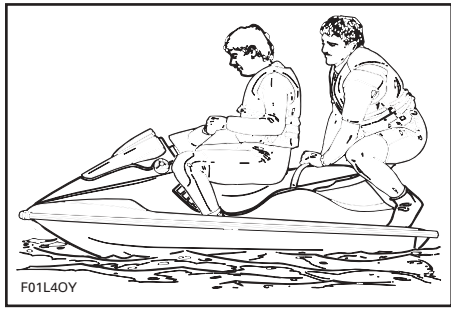
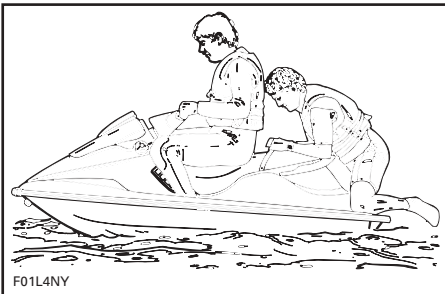

## Starting

### Preparation

Before unloading the watercraft from the trailer, it can be started for about 10 seconds to verify proper operation.

### WARNING

Certain components in the engine compartment may be very hot. Direct contact may result in skin burn. Do not touch electrical parts or jet pump area when engine is running.

Attach the safety lanyard to your PFD and snap the cap to its post before starting the engine.

**NOTE:** If you hear anything else than 2 short beeps from DESS system, it indicates a particular condition that should be corrected. Refer to the TROUBLESHOOTING section for the meaning of the coded signal.

### WARNING

Before starting the engine, the operator and passengers should always be properly seated.

Position shift lever to neutral.

Firmly grip handlebar with your left hand and place both feet on the footboard.

**CAUTION:** Ensure there is at least 90 cm (3 ft) of water underneath the rear portion of the hull when all passengers are aboard **prior to starting the engine**. Otherwise damage to the impeller or other jet pump components might occur.

To start engine, depress and hold the engine start/stop button. Follow procedure below for engine starting.

If engine fails to start after 10 seconds, wait a few seconds then repeat procedure.

**CAUTION:** Do not hold start/stop button more than 30 seconds to avoid starter overheating. A rest period should be observed between the cranking cycles to let starter cool down. Pay attention not to discharge battery. The engine should be started only after boarding, when there is at least 90 cm (3 ft) of water below the hull. Do not accelerate fast.

Release engine start/stop button immediately after engine is started.

### **Cold and Warm Engine**

Do not depress the throttle lever to start either a cold or warm engine.

### **Riding**

**Slowly** accelerate to reach deeper water. Do not apply full throttle until the engine is warm.

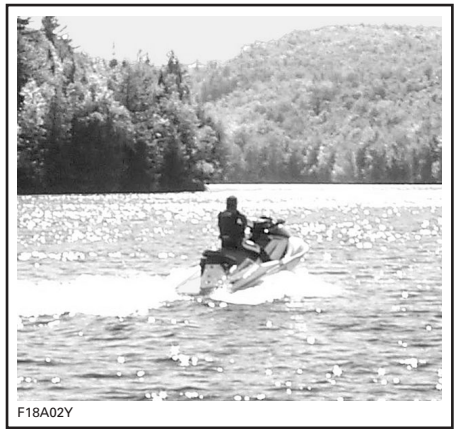

**CAUTION:** Avoid watercraft operation in weeded areas. If unavoidable, vary watercraft speed.

### **Rough Water or Poor Visibility Operation**

Avoid operation in these conditions. If you must do so, proceed with caution and prudence using minimum speed.

### **Crossing Waves**

Reduce speed.

Always be prepared to steer and balance as necessary.

When crossing wakes, always keep a safe distance from watercraft ahead.

### **⚠ WARNING**

When crossing wakes, slow down. Operator and passenger(s) can brace themselves by posting. Do not jump waves or wakes.

## Stopping / Docking

The watercraft is slowed by water drag. The stopping distance will vary depending on the watercraft size, weight, speed, water surface condition, presence and direction of wind and current.



The operator should become familiarized with the stopping distance under different conditions.

**RELEASE THE THROTTLE AT A SUFFICIENT DISTANCE BEFORE THE EXPECTED LANDING AREA.**

Reduce speed to idle.

Shift to neutral, reverse or forward, as required.

### **WARNING**

Directional control is reduced when the throttle is released and/or when engine is off.

## Beaching

**CAUTION:** It is not recommended to run the watercraft to the beach.

Come slowly to the beach and shut off the engine using the safety lanyard **before** water depth is less than 90 cm (3 ft) under the lowest rear portion of the hull, then pull the watercraft to the beach.

**CAUTION:** Riding the watercraft in shallower water might damage the impeller or other jet pump components.



**CAUTION:** Pay attention, when leaving the watercraft on the beach, so that the side vanes do not rub or hit the ground due to the rocking movement. It might eventually damage components of the O.P.A.S. system.

## Shutting Off the Engine

To keep watercraft directional control, the engine should be running until the watercraft is at idle.

To stop engine depress the start/stop button. When stopped, disconnect safety lanyard from the POST. It is suggested to release throttle lever first.

To shut off the engine, press the engine start/stop button. Remove safety lanyard from watercraft.

### **WARNING**

Should the engine be shut off, watercraft directional control is reduced. Never leave the safety lanyard on its post when watercraft is not in operation in order to prevent accidental engine starting or to avoid unauthorized use by children or others or theft.

---

# POST-OPERATION CARE

## WARNING

Allow engine to cool before performing any maintenance.

### General Care

Remove the watercraft from the water every day to prevent marine organisms growth.

Should any water be present in the hull, unscrew the drain plugs and tilt the watercraft to the rear in order to allow water to flow out. WIPE UP ANY REMAINING FLUID IN THE ENGINE COMPARTMENT (BILGE, ENGINE, BATTERY, ETC.) WITH CLEAN DRY RAGS (THIS IS PARTICULARLY IMPORTANT IN SALT WATER USE).

### Additional Care for Foul Water or Salt Water

When the watercraft is operated in foul water and particularly in salt water, additional care should be taken to protect the watercraft and its components. Rinse trailer and watercraft's bilge area with fresh water.

**CAUTION:** Failure to perform proper CARE SUCH AS: WATERCRAFT RINSING, EXHAUST COOLING system flushing and anticorrosion treatment, when watercraft is used in salt water, will result in damage to the watercraft and its components. Never leave the watercraft stored in direct sunlight.

## Exhaust Cooling System Flushing

### General

Flushing the exhaust cooling system with **fresh water** is essential to neutralize corroding effects of salt or other chemical products present in water. It will help to remove sand, salt, shells or other particles in water jackets and/or hoses.

Flushing should be performed when the watercraft is not expected to be used further the same day or when the watercraft is stored for any extended time.

## WARNING

Perform this operation in a well ventilated area.

Proceed as follows:

Clean jet pump by spraying water in its inlet and outlet and then apply a coating of BOMBARDIER LUBE lubricant or equivalent.

## WARNING

When operating the engine while the watercraft is out of the water, the heat exchanger in the ride plate may become very hot. Avoid any contact with ride plate as burns may occur.

## **Models without a Flushing Connector in Engine Compartment**

Connect a garden hose to connector located at the rear of watercraft on jet pump support. **Do not open water tap yet.**

**NOTE:** An optional quick connect adapter can be used (P/N 295 500 473). No hose pincher is required to flush engine.

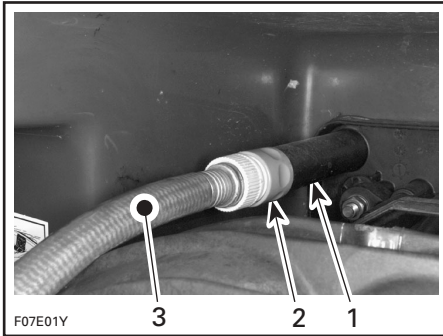

### **TYPICAL**

1. Hose adapter
2. Quick connect adapter (optional, not mandatory)
3. Garden hose

## **Models with a Flushing Connector in Engine Compartment**

This flushing connector allows flushing while watercraft is on a lift or if you prefer to flush from this location. Either flushing connector can be used to flush the exhaust cooling system. The one at the jet pump support (see above) or the one in the engine compartment (see below).

Remove seat to gain access.

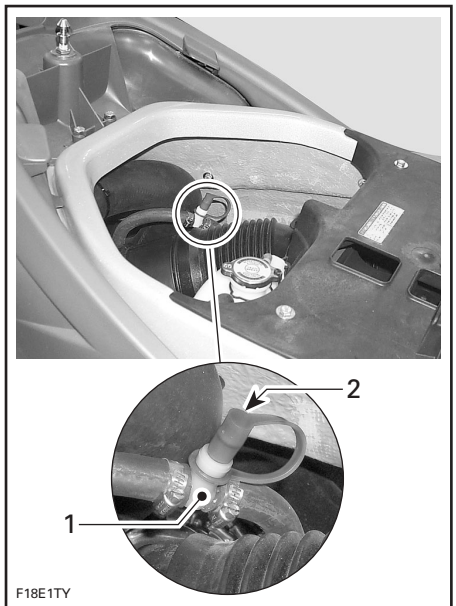

1. Flushing connector
2. Dust cap

Remove dust cap from flushing connector and attach coupler hose (supplied in rear storage compartment). Make sure coupler hose is properly locked to flushing connector. Install a hose pincher (supplied inside tool kit in rear storage compartment) on water outlet hose.

**NOTE:** This prevents water from directly exiting exhaust cooling system.

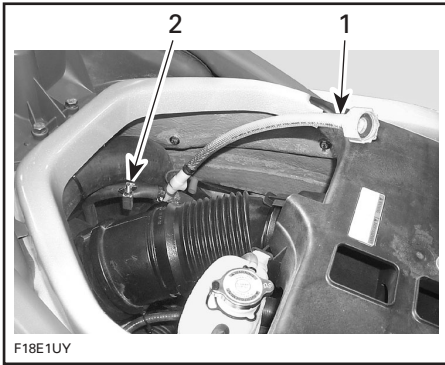

1. Coupler hose
2. Hose pincher

Attach other end of coupler hose to a garden hose. Do not open water tap yet.

## Flushing

### All Models

To flush the exhaust cooling system, start the engine then immediately open the water tap.

## WARNING

Certain components in the engine compartment may be very hot. Direct contact may result in skin burn. Do not touch any electrical parts or jet pump area when engine is running.

**CAUTION:** Never flush a hot engine. Always start the engine before opening the water tap. Open water tap immediately after engine is started to prevent overheating.

Run the engine about 20 seconds at a fast idle between 4000 - 5000 RPM.

**CAUTION:** NEVER RUN ENGINE WITHOUT SUPPLYING WATER TO THE EXHAUST COOLING SYSTEM WHEN WATERCRAFT IS OUT OF WATER.

Ensure water flows out of jet pump while flushing. Otherwise, refer to an authorized Sea-Doo dealer for servicing.

**CAUTION:** NEVER RUN ENGINE LONGER THAN 5 MINUTES. DRIVE LINE SEAL HAS NO COOLING WHEN WATERCRAFT IS OUT OF WATER.

Close the water tap, then stop the engine.

**CAUTION:** Always close the water tap before stopping the engine.

### **Models without a Flushing Connector under Seat**

**CAUTION:** Remove quick connect adapter after flushing operation (if used).

### **Models with a Flushing Connector in Engine Compartment**

UNLOCK AND REMOVE COUPLER HOSE. REINSTALL DUST CAP OVER FLUSHING CONNECTOR.

Remove hose pincher from water outlet hose.

**CAUTION:** Serious engine damage can occur if hose pincher is not removed.

## Anticorrosion Treatment

To prevent corrosion, spray a corrosion inhibitor (salt water resistant) such as BOMBARDIER LUBE lubricant or equivalent over metallic components in engine compartment.

Apply dielectric grease (salt water resistant) on battery posts and cable connectors.

**CAUTION:** Never leave rags or tools in the engine compartment or in the bilge.



---

# SPECIAL PROCEDURES

## Monitoring System

To assist you when using the watercraft, a system monitors the electronic components of the EMS (engine management system) and other components of the electrical system. When a fault occurs, it sends visual messages through the information center and/or audible signals through a beeper to inform you of a particular condition. Refer to the INFORMATION CENTER for the displayed messages and the TROUBLESHOOTING section for the beeper coded signals chart.

When minor faults occur, the fault and message/beeper will disappear automatically if the condition does not exist anymore.

Releasing throttle and letting the engine returning at idle speed may allow normal operation to come back. If it does not work, try removing and reinstalling the safety lanyard on its POST.

The electronic system will react differently depending on the fault type. In severe failure, the engine might not be allowed to be started. In other cases, the engine will operate in limp home mode. See below.

When a fault occurs, see an authorized Sea-Doo dealer as soon as possible for inspection.

## Limp Home Modes

Besides the signals as seen above, the EMS may automatically set default parameters to ensure the adequate operation of the watercraft if an electronic component is not operating properly.

Depending on the severity of the malfunction, the watercraft speed may be reduced and not allowed to reach its top speed as usual.

In this mode, it may be necessary to depress the throttle quite slowly to allow engine RPM to increase and operate the watercraft to go back home.

These performance-reduced modes allow the rider to go back home which would not be possible without this advanced system.

## Engine Overheating

**CAUTION:** If the monitoring beeper continuously sounds, **stop engine as soon as possible.**

Check coolant level. Refer to LIQUIDS. If engine still overheats, continue the following procedure.

PERFORM JET PUMP WATER INTAKE AND IMPELLER CLEANING procedure described in this section.

When back to shore, flush exhaust cooling system, refer to POST-OPERATION CARE.

If engine still overheats, refer to an authorized Sea-Doo dealer for servicing.

## Engine Low Oil Pressure

**CAUTION:** If the monitoring beeper continuously sounds, **stop engine as soon as possible.**

Turn off engine as soon as possible. Check oil level and refill.

Restart the engine. If this does not correct the situation, do not run the engine further. Refer to an authorized Sea-Doo dealer for servicing.

**CAUTION:** Running engine with low oil pressure may severely damage the engine.

## Jet Pump Water Intake and Impeller Cleaning

### WARNING

Keep away from intake grate while engine is on. Items such as long hair, loose clothing or personal flotation device straps can become entangled in moving parts resulting in severe injury or drowning.

Weeds, shells or debris can get caught on the intake grate, drive shaft and/or impeller. A clogged water intake may cause troubles such as:

1. **CAVITATION:** ENGINE SPEED IS HIGH BUT WATERCRAFT MOVES SLOWLY DUE TO REDUCED JET THRUST, JET PUMP COMPONENTS MAY BE DAMAGED.
2. **Overheating:** Since the jet pump operation controls the flow of water to cool the exhaust system, a clogged intake will cause the engine to overheat and damage engine internal components.

A weed clogged area can be cleaned as follows:

## In-Water Cleaning

Rock the watercraft several times while repeatedly pressing engine start/stop button for short period without starting engine. Most of the time, this will remove the blockage. Start engine and make sure watercraft operates properly.

IF SYSTEM IS STILL BLOCKED, MOVE THE WATERCRAFT OUT OF THE WATER AND REMOVE BLOCKAGE MANUALLY.

IF THE AFOREMENTIONED METHOD DOES NOT WORK, THE FOLLOWING CAN BE PERFORMED:

- **With engine running and before applying throttle, put shift lever in reverse position and vary throttle quickly several times.**
- Repeat procedure if necessary.

## On-Beach Water Cleaning

### WARNING

Always remove safety lanyard cap from its post to prevent accidental engine starting before cleaning the jet pump area.

PLACE A CARDBOARD OR A CARPET BESIDE THE WATERCRAFT TO PREVENT SCRATCHING WHEN TURNING THE WATERCRAFT FOR CLEANING.

Rotate the watercraft to any side for cleaning.

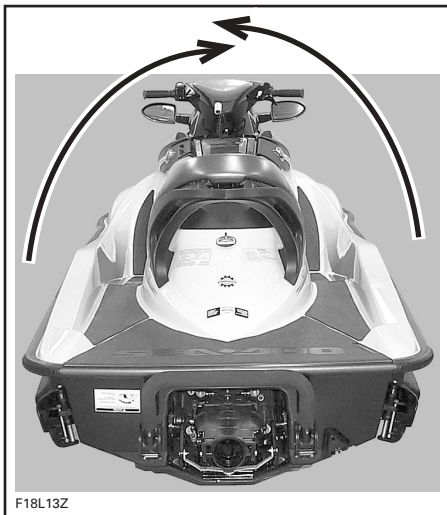

Clean the water intake area. If the system is still clogged, refer to an authorized Sea-Doo dealer for servicing.

**CAUTION:** INSPECT WATER INTAKE GRATE FOR DAMAGE. REFER TO AN AUTHORIZED SEA-DOO DEALER for repair as necessary.

### Capsized Watercraft

The watercraft is designed so that it should not turn over easily. Also two sponsons mounted on the side of the hull assist watercraft stability. If it turns over, it will remain capsized.

#### **WARNING**

When watercraft is capsized, do not attempt to restart the engine. Operator and passengers should always wear approved personal flotation devices.

To return the watercraft upright, ensure the engine is off and the safety lanyard is NOT on its post then grab the inlet grate, step on bumper rail and use your weight to rotate the watercraft in any direction.

The 4-TEC engine features a tip-over protection system (T.O.P.S.™). When watercraft tips over, engine is automatically stopped, then a valve is closed to prevent engine oil to flow back in intake system.

When watercraft is returned to its normal operating position, engine can then be started normally.

**CAUTION:** If watercraft has been capsized for more than 5 minutes, do not attempt to crank engine to avoid water ingestion that would damage the engine. See an authorized Sea-Doo dealer as soon as possible.

**CAUTION:** If engine does not crank, do not attempt to start engine anymore. Otherwise engine could be damaged. See an authorized Sea-Doo dealer as soon as possible.

As soon as possible, check for presence of water in the bilge. Drain as necessary when back to the shore.

### Submerged Watercraft

To limit damages to the engine, perform the following procedure as soon as possible.

Drain bilge.

IF IT WAS SUBMERGED IN SALT WATER, SPRAY BILGE AND ALL COMPONENTS WITH FRESH WATER USING A GARDEN HOSE TO STOP THE SALT CORRODING EFFECT.

**CAUTION:** Never try to crank or start the engine. Water trapped in intake manifold would flow towards the engine and may cause severe damage to the engine.

Bring the watercraft to be serviced by an authorized Sea-Doo dealer as soon as possible.

**CAUTION:** The longer the delay before you have the engine serviced, the greater the damage will be to the engine.

## Water-Flooded Engine

**CAUTION:** Never try to crank or start the engine. Water trapped in intake manifold would flow towards the engine and may cause severe damage to the engine.

Bring the watercraft to be serviced by an authorized Sea-Doo dealer as soon as possible.

**CAUTION:** The longer the delay before you have the engine serviced, the greater the damage will be to the engine. Failure to have the engine properly serviced may cause severe engine damage.

## Fuel-Flooded Engine

When the engine does not start after several attempts, the engine may be fuel-flooded. Proceed as follows.

To prevent fuel to be injected and also to cut the ignition at the engine cranking, proceed as follows.

While engine is stopped, fully depress throttle lever and HOLD for cranking.

Crank engine several times.

### If it does not work:

Pull engine cover upward to remove it.

Disconnect ignition coil connectors.

## WARNING

When disconnecting coil from spark plug, always disconnect coil from main harness first. Never check for engine ignition spark from an open coil and/or spark plug in the engine compartment as spark may cause fuel vapor to ignite.

Remove ignition coils.

**CAUTION:** Ensure there is no dirt in coil holes prior to removing the spark plugs. Otherwise, dirt would fall into cylinder and will damage the internal components.

Remove spark plugs.

**NOTE:** After untightening the spark plugs, a coil may be used to pull the spark plugs out. Simply bring the coil down to spark plug and “hook” it to then extract spark plug.

Install new spark plugs if available or dry spark plugs using a rag.

Cover spark plug holes with a rag.

Crank engine several times while keeping throttle fully depressed.

Reinstall spark plugs and ignition coils. Install clean dry spark plugs if possible. Reconnect ignition coil connector.

**NOTE:** Prior to inserting the ignition coil to its location, apply some Molykote 111 grease (P/N 413 707 000) around the seal area that touches the spark plug hole. After installation, ensure the seal seats properly with the engine top surface.

To reinstall engine cover, push it downward until it snaps.

Start engine as explained above. If engine continues to flood, see an authorized Sea-Doo dealer.

**CAUTION:** NEVER RUN ENGINE WITHOUT SUPPLYING WATER TO THE EXHAUST COOLING SYSTEM WHEN WATERCRAFT IS OUT OF WATER.

## Towing the Watercraft in Water

Special precautions should be taken when towing a SEA-DOO watercraft in water. Maximum recommended towing speed is 24 km/h (15 MPH).

When towing your watercraft in water, pinch the water supply hose from the impeller housing to the exhaust manifold with a large hose pincher (P/N 529 032 500).

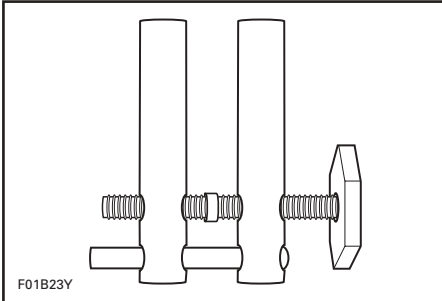

This will prevent the exhaust cooling system from filling which may lead to water being injected into and filling the engine. Without the engine running there isn't any exhaust pressure to carry the water out the exhaust outlet.

**CAUTION:** Failure to do this may result in damage to the engine. If you must tow a stranded watercraft in water and do not have a hose pincher, be sure to stay well below the maximum towing speed of 24 km/h (15 MPH).

To ease access to the hose, the vent tube can be temporarily removed.

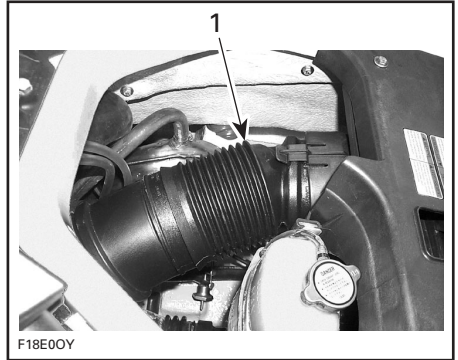

### 1. Vent tube

Lift lock tab and holding the tab, pull the tube to release it.

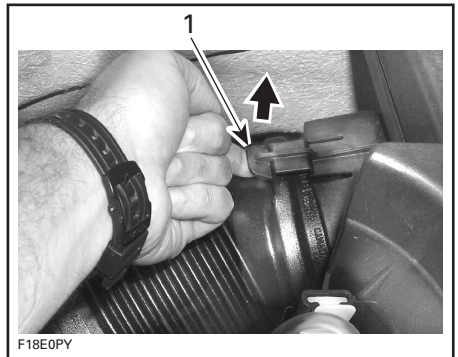

### 1. Lift lock tab

Then proceed with the tab under the tube. Refer to the following illustration to see it.

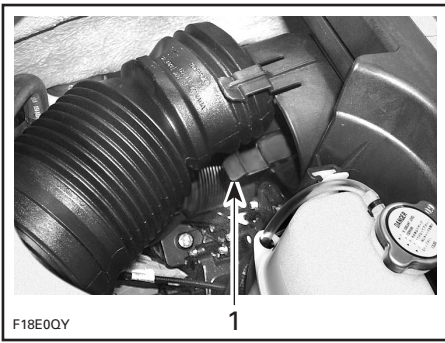

1. Other lock tab under tube

Snugly install the hose pincher on the water supply hose as shown.

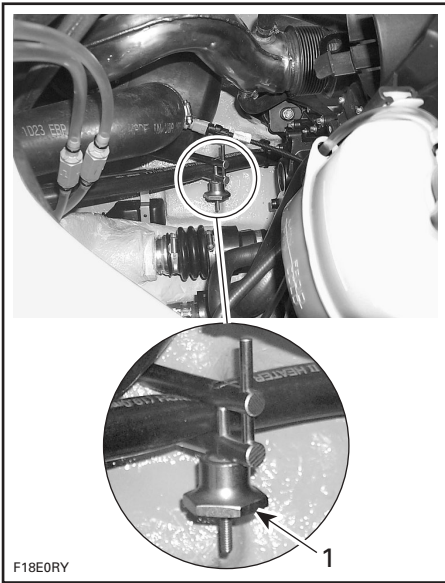

**TYPICAL**

1. Hose pincher

**CAUTION:** WHEN FINISHED TOWING THE WATERCRAFT, HOSE PINCHER SHOULD BE REMOVED BEFORE OPERATING IT. FAILURE TO DO SO WILL RESULT IN DAMAGE TO THE ENGINE.

After removal of hose pincher, properly reinstall and lock vent tube. When pushing tube in place, you should hear a click that validates it is locked.

### Low-Charge Battery Condition

See an authorized Sea-Doo dealer to have it charged or replaced.

**⚠ WARNING**

Do not charge or boost the battery while installed on the watercraft. Electrolyte is poisonous and dangerous. Avoid contact with eyes, skin and clothing.

---

# MAINTENANCE

Maintenance, replacement, or repair of the emission control devices and systems may be performed by any marine SI (spark ignition) engine repair establishments or individual.

## Engine Emissions Information

### Manufacturer's Responsibility

Beginning with 1999 model year engines, PWC manufacturers of marine engines must determine the exhaust emission levels for each engine horsepower family and certify these engines with the United States of America Environmental Protection Agency (EPA). An emissions control information label, showing emission levels and engine specifications, must be placed on each vehicle at the time of manufacture.

### Dealer's Responsibility

When performing service on all 1999 and more recent SEA-DOO WATERCRAFTS THAT CARRY AN EMISSIONS CONTROL INFORMATION-LABEL, ADJUSTMENTS MUST BE KEPT WITHIN PUBLISHED FACTORY SPECIFICATIONS.

Replacement or repair of any emission related component must be executed in a manner that maintains emission levels within the prescribed certification standards.

Dealers are not to modify the engine in any manner that would alter the horsepower or allow emission levels to exceed their predetermined factory specifications.

Exceptions include manufacturer's prescribed changes, such as altitude adjustments for example.

## Owner Responsibility

The owner/operator is required to have engine maintenance performed to maintain emission levels within prescribed certification standards.

The owner/operator is not to, and should not allow anyone to modify the engine in any manner that would alter the horsepower or allow emissions levels to exceed their predetermined factory specifications.

## EPA Emission Regulations

All new 1999 and more recent SEA-DOO watercraft manufactured by Bombardier are certified to the EPA as conforming to the requirements of the regulations for the control of air pollution from new watercraft engines. This certification is contingent on certain adjustments being set to factory standards. For this reason, the factory procedure for servicing the product must be strictly followed and, whenever practicable, returned to the original intent of the design.

The responsibilities listed above are general and in no way a complete listing of the rules and regulations pertaining to the EPA requirements on exhaust emissions for marine products. For more detailed information on this subject, you may contact the following locations:

### VIA U.S. POSTAL SERVICE:

Office of Mobile Sources  
Engine Programs and Compliance  
Division  
Engine Compliance Programs  
Group (6403J)  
401 M St. NW  
Washington, DC 20460

## VIA EXPRESS or COURIER MAIL:

Office of Mobile Sources  
Engine Programs and Compliance  
Division  
Engine Compliance Programs  
Group (6403J)  
501 3<sup>rd</sup> St. NW  
Washington, DC 20001

## EPA INTERNET WEB SITE:

www.epa.gov

### **WARNING**

Only perform procedures as detailed in this guide. It is recommended that the assistance of an authorized Sea-Doo dealer be periodically obtained on other components/ systems not covered in this guide. Unless otherwise specified, engine must not be running and the safety lanyard must be removed from its post for all maintenance procedures. Never use jet pump components or side vanes to lift the watercraft. Certain components in the engine compartment may be very hot. Direct contact may result in skin burn. When operating the engine while the watercraft is out of the water, the heat exchanger in the ride plate may become very hot. Avoid any contact with ride plate as burns may occur.

## Lubrication

### Anticorrosion Protection

#### Throttle Cable

Lubricate the throttle cable with BOMBARDIER LUBE lubricant or equivalent.

#### Electrical Connections

As necessary, apply anticorrosion product such as dielectric grease on battery posts and all exposed cable connectors.

**CAUTION:** Do not lubricate connectors of the Multi-Purpose Electronic Module (MPEM) and the engine Electronic Control Unit (EMS ECU).

#### Additional Lubrication

BOMBARDIER LUBE lubricant or equivalent will help prevent corrosion of metallic parts and maintain proper operation of moving mechanisms.

### **WARNING**

Do not lubricate the safety lanyard post.

#### Ski/Wake Board Post (if so equipped)

Lubricate ski/wake board post through all its length. Pull out then push in several times to distribute the lubricant.

#### Reverse Gate

Lubricate pivoting points and mechanism.

## Periodic Inspection

Routine maintenance is necessary for all mechanized products. A periodic inspection contributes to the product's life span.

The following maintenance chart gives guidelines for regular watercraft servicing scheduled to be performed by you and/or by an authorized Sea-Doo dealer. The schedule should be adjusted according to operating conditions and use.

**NOTE:** The chart gives an equivalence between number of hours and months/ year. Perform the maintenance operation to whatever time comes first.

**IMPORTANT:** Schedule for watercraft rental operations or higher number of hour use, will require greater frequency of inspection and maintenance.



# Periodic Inspection Chart

DESCRIPTION I: Inspect, verify, clean, adjust, lubricate, replace if necessary C: Clean L: Lubricate R: Replace		FREQUENCY				
		FIRST 10 HOURS	EVERY 25 HOURS OR 3 MONTHS	EVERY 50 HOURS OR 6 MONTHS	EVERY 100 HOURS OR 1 YEAR	TO BE PERFORMED BY
<b>GENERAL</b>	Lubrication/corrosion protection			L		C
<b>ENGINE</b>	Engine oil and filter	R			R	D
	Support and rubber mount condition/ tightness	I			I	D
	Condition of seals and fasteners	I		I		D
	Exhaust system fasteners ⑤	I			I	D
	Spark plug ⑥				R	D
<b>COOLING SYSTEM</b>	Flushing (exhaust system)		C ③			C
	Hose condition and fasteners	I			I	D
	Coolant				⑦	D
	Coolant expansion tank cap/cooling system pressure test				④	D
<b>FUEL SYSTEM</b>	Throttle cable		I			C
	Fuel injection system sensors	I			I	D
	Throttle body. Fault code reading ⑥ ①				I	D
	Fuel vent line pressure relief valve				I	D
	Fuel lines, connections and fuel system pressurization ⑤	I			I	D
	Throttle body, sensors, fuel lines, fuel rail and fittings ⑤	I			I	D
	Air intake silencer fit/tightness	I			I	D
	Fuel tank straps	I			I	C
<b>ELECTRICAL SYSTEM</b>	Electrical connections condition and fastening (ignition system, starting system, fuel injectors etc.)	I			I	D
	Check fault codes	I			I	D
	MPEM and EMS ECU connectors				I ①	D
	MPEM mounting brackets/fasteners				I	D
	Digitally Encoded Security System and safety lanyard/post condition	I			I	D
	Monitoring beeper	I			I	D
	Battery condition and fasteners	I		I		D
<b>STEERING SYSTEM</b>	Steering cable	I		I		D

DESCRIPTION I: Inspect, verify, clean, adjust, lubricate, replace if necessary C: Clean L: Lubricate R: Replace		FREQUENCY				
		FIRST 10 HOURS	EVERY 25 HOURS OR 3 MONTHS	EVERY 50 HOURS OR 6 MONTHS	EVERY 100 HOURS OR 1 YEAR	TO BE PERFORMED BY
<b>O.P.A.S. SYSTEM</b>	O.P.A.S. system including filter	I	I ⑧	I		D
<b>PROPULSION SYSTEM</b>	Drive shaft protection boot			I ②		D
	Grease splines in jet pump			L		D
	Shifter system/cable	I			I	D
	Impeller shaft seal, sleeve and O-ring				⑥	D
	Impeller condition and impeller/wear ring clearance				I ②	D
	Water intake grate condition				I ②	C
	Ride plate inspection including coolant leak	I			I	D
	Drive shaft/hull sealing system	I			I	D
<b>HULL AND BODY</b>	Bailer pick-ups, check for obstructions	I			I	C
	Hull condition	I			I	C
	Ski/wake board post condition and fasteners	I		I		C

**NOTE:** Some items are included in the PRE-OPERATION CHECKS and not necessarily repeated in this chart.

D: Dealer

C: Customer

① In salt water use.

② These items have to be initially checked after 25 hours. Thereafter, servicing to be made as specified in this chart.

③ Daily flushing in salt water or foul water use.

④ Perform every 200 hours or 2 years.

⑤ Emission-related component.

⑥ Replace after the vehicle completed 100 hours of use or 2 years.

⑦ Replace for storage period or after 100 hours of use whichever comes first.

⑧ Every 25 hours when riding in weed areas.

## Throttle Cable Inspection

### Throttle Cable

Depress and release the throttle lever. It should operate smoothly and return to its initial position without any hesitation. There must be a small amount of free-play when throttle lever is released. Refer to an authorized Sea-Doo dealer if necessary.

**CAUTION:** Never attempt to adjust the idle speed through the throttle body tamper proof screw. If so, it would impair the idle speed stability. Besides, no adjustment could be performed by the dealer nor the factory to correct the idle speed. The throttle body would need to be replaced at the customer expense. Also take into account that might change the engine emission level and the engine might not meet the EPA/CARB requirements.



### WARNING

Do not alter or tamper with throttle cable adjustment or routing.



### WARNING

If throttle lever does not automatically return, do not operate watercraft and see your authorized Sea-Doo dealer.

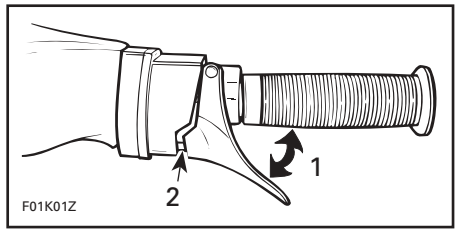

1. Should move freely
2. Slight free-play must be present here

## Engine Oil Change and Oil Filter Replacement

The oil change and filter replacement should be performed by an authorized Sea-Doo dealer.

## Valve Adjustment

There is no valve adjustment to be performed on this engine.

## Coolant Replacement

The coolant replacement should be performed by an authorized Sea-Doo dealer.

## Fuel Injection System

The fuel injection system inspection should be performed by an authorized Sea-Doo dealer. Fuel system pressurization should be conducted at the same time.

## Steering Alignment

When the handlebar is directed in straight ahead position, the jet pump nozzle should be in the same direction allowing the watercraft to run in a straight line. The rear edge of side vanes should be pointing out side by approximately 20° when the handlebar is pointing straight ahead.

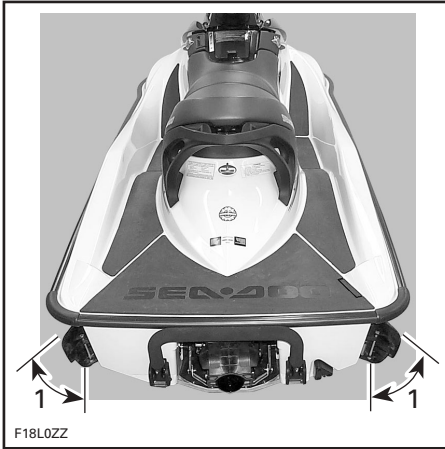

1. Approximately 20° when handlebar is pointing straight ahead

Refer to an authorized Sea-Doo dealer if an adjustment is necessary.

### **WARNING**

Ensure the handlebar and jet pump nozzle operate freely from side to side and are not stressing the steering cable or brackets. Never turn handlebar while someone is nearby rear of watercraft. Keep away from steering moving parts (nozzle, side vanes, linkage etc.).

## Vacuum Bailer Pick-Ups

They are located each side of the drive shaft tunnel.

Two pick-ups use a low pressure area in the jet pump to siphon the water out of the bilge when the engine is operating.

Inspect each pick-up screen for obstructions, clean as necessary.

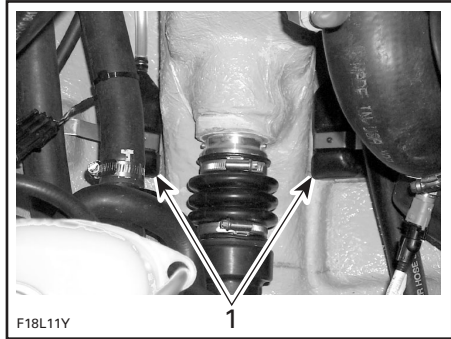

### TYPICAL

1. Vacuum bailer pick-ups

## Fuses

If an electrical problem occurs, check the fuses. If a fuse is burnt, replace by one of the same rating.

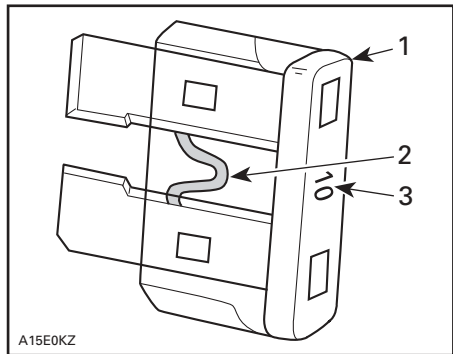

1. Fuse
2. Check if melted
3. Ampere rating

Follow procedures below.

## **WARNING**

Do not use a higher rated fuse as this can cause severe damage. If a fuse has burnt out, source of malfunction should be determined and corrected before re-starting. See an authorized Sea-Doo dealer for servicing.

Fuses can be found on the MPEM in engine compartment.

**NOTE:** To understand the acronyms used here, refer to ABBREVIATIONS USED IN THIS MANUAL section at the end of the guide.

### **MPEM**

TO ACCESS FUSES ON THE MPEM, REMOVE SEAT.

Locate MPEM besides engine.

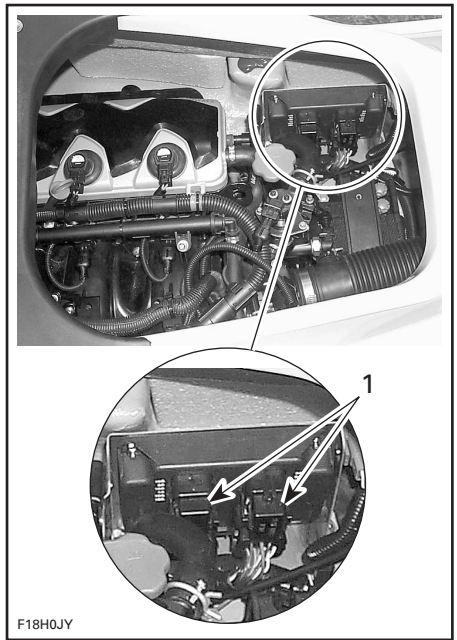

F18H0JY

**TYPICAL**  
1. Fuses

Fuses rating are identified, look besides the fuse holders.

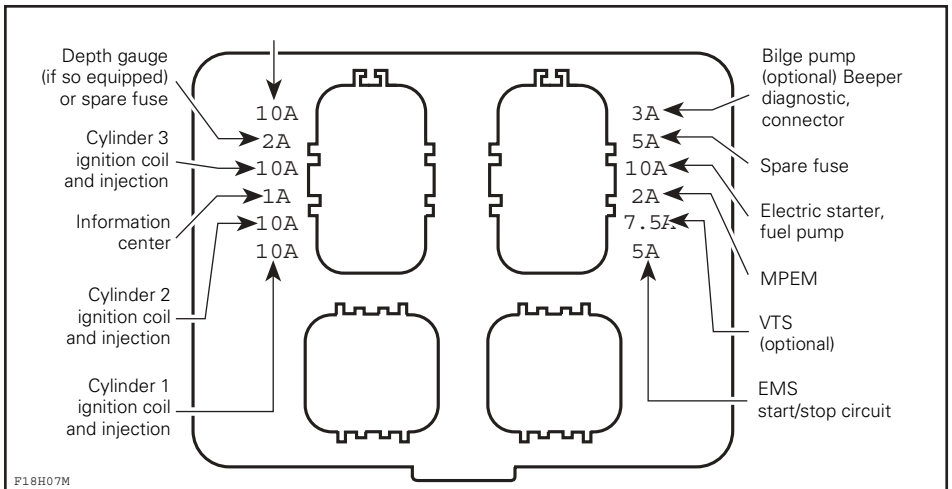

F18H07M

**FUSE IDENTIFICATION**

Squeeze locking tabs together, hold and pull fuse cover from the MPEM.

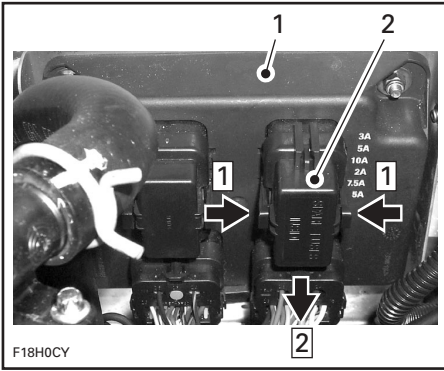

**TYPICAL**

1. MPEM
2. Fuse cover

Use the tabs of the fuse cover to remove and reinstall fuses. Slide cover tabs along fuse top.

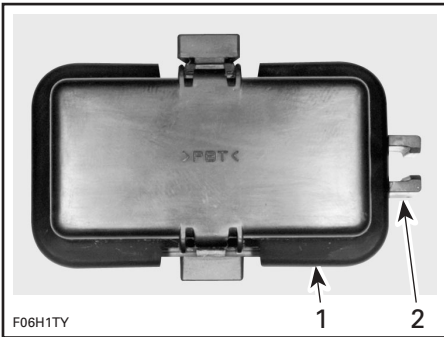

1. Fuse cover
2. Fuse tabs

One cover contains spare fuses.

To gain access to spare fuses, remove the cover identified "SPARE FUSES INSIDE". Look inside cover and pull the rubber protector with a finger. Take care not to drop the fuses.

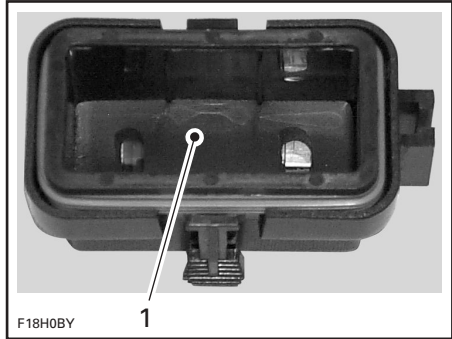

1. Rubber protector

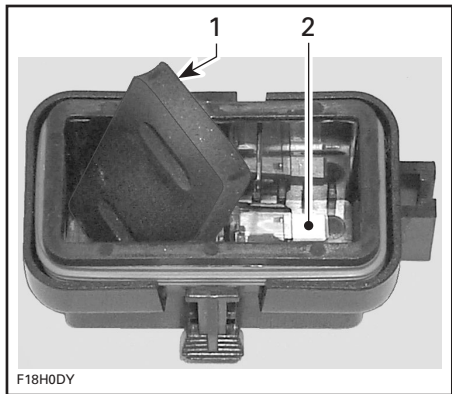

1. Rubber protector
2. Spare fuses

When finished, reinstall the remaining fuse(s) and reinstall the protector over fuse(s).

**CAUTION:** Do not install more than 4 fuses in cover to allow proper installation of cover.

## Main Fuses

They are located besides the MPEM. See below for details.

### Main Fuse besides MPEM

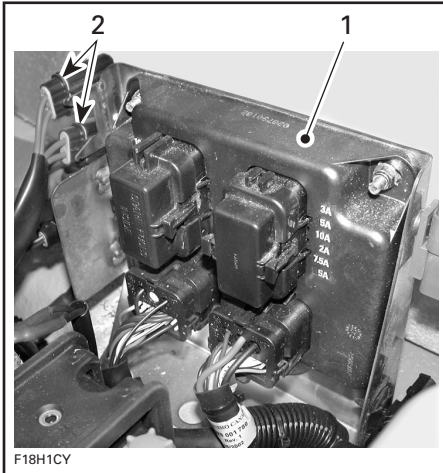

1. MPEM
2. Main fuse

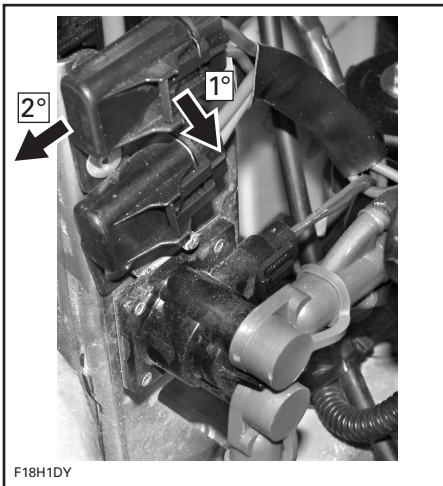

To remove fuse, lift tab while pulling holder out. Pull fuse out using cover on MPEM as shown above.

TO REMOVE FUSE, LIFT TAB THEN PULL HOLDER OUT. PULL FUSE OUT USING COVER ON MPEM AS SHOWN ABOVE. Reassemble removed parts.

## O.P.A.S. System (if so equipped)

The O.P.A.S. system operation and condition should be checked by an authorized Sea-Doo dealer.

## Ski/Wake Board Post (if so equipped)

Check ski/wake board post operation. Ensure it slides up and down easily. Check locking mechanism operation. Check fasteners tightness. If something is found defective, don't use ski/wake board post and see an authorized Sea-Doo dealer for repair.

## General Inspection and Cleaning

### Inspection

Check engine compartment for any damage and for leaks of fuel, coolant or oil. Ensure all hose clamps are properly secured and no hose is cracked, kinked or presenting any other damage.

## WARNING

If any gasoline leak and/or odor are present, do not start the engine. Have the watercraft serviced by an authorized Sea-Doo dealer.

Inspect muffler, battery, fuel tank and oil reservoir fastening devices. Visually check electrical connections for corrosion and tightness. Inspect hull and jet pump water intake grate for damage. Replace or have damaged parts repaired.



## WARNING

Periodically verify the seat lock pin and tighten if needed. Make sure seat securely latches.

## Cleaning

The bilge should be cleaned by an authorized Sea-Doo dealer to remove any fuel/oil/electrolyte deposits and mildew.

Occasionally, wash the body with water and soap (only use mild detergent). Remove any marine organisms from engine and/or hull. Apply non-abrasive wax such as silicone wax.

**CAUTION: Never clean fiberglass and plastic parts with strong detergent, degreasing agent, paint thinner, acetone, etc.**

Stains may be removed from seat and fiberglass with Knight's Spray-Nine from Korkay System Ltd or the equivalent.

Respect the environment by ensuring fuel, oil or cleaning solutions do not drain into the waterways.



# TRAILERING, STORAGE AND PRE-SEASON PREPARATION

## Trailing

**CAUTION:** To avoid damaging O.P.A.S. side vanes, the maximum trailer wood bunks span including bunk width should not exceed 71 cm (28 in). Ends of both trailer wood bunks should not be more than 2.59 m (102 in) away from watercraft bow attachment point. See following illustration.

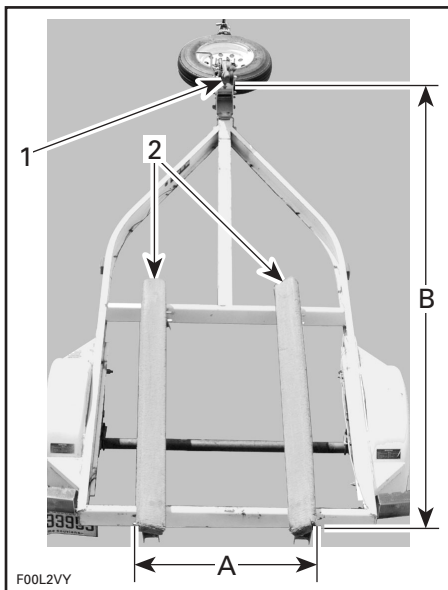

### TRAILER FOR O.P.A.S.

1. Watercraft front (bow) attachment point
  2. Wood bunks
- A. 71 cm (28 in)  
B. 2.59 m (102 in)

Make sure that fuel tank cap is properly installed.

## WARNING

Never tip this vehicle on end for transporting. We recommend that you carry the vehicle in its normal operating position.

Check the applicable laws and regulations in your area concerning towing a trailer, especially the following rules:

- brake system
- tow vehicle weight
- mirrors.

Take the following precautions when towing the watercraft:

Tie the watercraft to both front and rear (bow/stern) eyelets so that it is firmly retained on the trailer. Use additional tie-downs if necessary.

**CAUTION:** Do not route ropes or tie-downs over the seat or grab handle as they could produce permanent damage. Wrap ropes or tie-downs with rags or similar protectors where they can touch the watercraft body.

Ensure all storage compartment covers and seat are properly latched.



## WARNING

Make sure seat is securely latched before prior to trailering.

A SEA-DOO cover can protect the watercraft, particularly before driving on dirt roads, to prevent dirt entry through the air intake openings.

Observe trailering safety precautions.

## Launching/Loading

**CAUTION:** Before launching the watercraft, ensure the bilge drain plugs are fully screwed. After loading the watercraft, ensure they are removed to drain bilge.

## Storage



## WARNING

BECAUSE FUEL AND OIL ARE FLAMMABLE, have an authorized Sea-Doo dealer inspect the fuel system integrity as specified in the periodic inspection chart.

It is recommended that the watercraft be serviced by an authorized Sea-Doo dealer for storage but the following operations can be performed by you with a minimum of tools.

**CAUTION:** Do not run the engine during the storage period.

## Body Rinsing/Repair

Wash the body with soap and water solution (only use mild detergent). Rinse thoroughly with **fresh water**. Remove marine organisms from the hull.

**CAUTION:** Never clean fiberglass and plastic parts with strong detergent, degreasing agent, paint thinner, acetone, etc. For gelcoat repairs, refer to an authorized Sea-Doo dealer. Replace damaged labels/decals.

## Fuel System

SEA-DOO FUEL STABILIZER (OR EQUIVALENT), CAN BE ADDED IN FUEL TANK TO PREVENT FUEL DETERIORATION AND FUEL SYSTEM GUMMING. FOLLOW STABILIZER MANUFACTURER'S INSTRUCTIONS FOR PROPER USE.

**CAUTION:** Fuel stabilizer should be added prior to engine lubrication to ensure fuel system components protection against varnish deposits.



## WARNING

ALWAYS STOP THE ENGINE BEFORE REFUELING. FUEL IS INFLAMMABLE AND EXPLOSIVE UNDER CERTAIN CONDITIONS. ALWAYS WORK IN A WELL VENTILATED AREA. DO NOT SMOKE OR ALLOW OPEN FLAMES OR SPARKS IN THE VICINITY. FUEL TANK MAY BE PRESSURIZED, TURN CAP SLOWLY WHEN OPENING. NEVER USE AN OPEN FLAME TO CHECK FUEL LEVEL. WHEN FUELING, KEEP WATERCRAFT LEVEL. DO NOT OVERFILL OR TOP OFF THE FUEL TANK AND LEAVE WATERCRAFT IN THE SUN. AS TEMPERATURE INCREASES, FUEL EXPANDS AND MIGHT OVERFLOW. ALWAYS WIPE OFF ANY FUEL SPILLAGE FROM THE WATERCRAFT. PERIODICALLY VERIFY FUEL SYSTEM. ALWAYS TURN THE FUEL TANK VALVE (**IF SO EQUIPPED**) TO OFF POSITION WHEN THE WATERCRAFT IS NOT IN USE.

## Engine Oil and Filter Replacement

The oil change and filter should be performed by an authorized Sea-Doo dealer.

## Exhaust Cooling System Flushing and Engine Internal Lubrication

### Lubrication

Connect a garden hose to cool the exhaust system as explained in FLUSHING under POST-OPERATION CARE.

Bring engine to normal operating temperature.

**CAUTION:** Properly follow the instructions given in the flushing procedure.

Close the water tap, then stop the engine.

Pull engine cover upward to remove it.

Disconnect ignition coil connectors.

### WARNING

When disconnecting coil from spark plug, always disconnect coil from main harness first. Never check for engine ignition spark from an open coil and/or spark plug in the engine compartment as spark may cause fuel vapor to ignite.

**IMPORTANT:** Never cut the locking ties of ignition coil connectors. This would allow mixing the wires between cylinders.

Remove ignition coils.

**CAUTION:** Ensure there is no dirt in coil holes prior to removing the spark plugs. Otherwise, dirt would fall into cylinder and will damage the internal components.

Remove spark plugs.

**NOTE:** After untightening the spark plugs, a coil may be used to pull the spark plugs out. Simply bring the coil down to spark plug and "hook" it to then extract spark plug.

Spray BOMBARDIER LUBE lubricant or equivalent, in spark plug holes.

To prevent fuel to be injected and also to cut the ignition at the engine cranking, proceed as follows.

While engine is stopped, fully depress throttle lever and HOLD for cranking.

Crank the engine a few turns to distribute the oil on cylinder wall.

Apply anti-seize lubricant on spark plug threads then reinstall them.

**NOTE:** Prior to inserting the ignition coil to its location, apply some Molykote 111 grease (P/N 413 707 000) around the seal area that touches the spark plug hole. After installation, ensure the seal seats properly with the engine top surface.

Reinstall ignition coils. Reconnect ignition coil connectors.

To reinstall engine cover, push it downward until it snaps.

Wipe up any residual water from the engine.

Disconnect the garden hose.

**NOTE:** It is recommended to fog the engine valves with BOMBARDIER LUBE lubricant. Contact your authorized Sea-Doo dealer.

## Battery

Contact your authorized Sea-Doo dealer.

## ENGINE COOLING SYSTEM

Antifreeze should be replaced for the storage period to prevent antifreeze deterioration.

The antifreeze replacement and a density test should be performed by an authorized Sea-Doo dealer.

**CAUTION: IMPROPER ANTIFREEZE MIXTURE MIGHT ALLOW FREEZING OF THE LIQUID IN THE COOLING SYSTEM IF VEHICLE IS STORED IN AREA WHERE FREEZING POINT IS REACHED. THIS WOULD SERIOUSLY DAMAGE THE ENGINE. FAILURE TO REPLACE THE ANTIFREEZE FOR STORAGE MAY ALLOW ITS DEGRADATION THAT COULD RESULT IN POOR COOLING WHEN ENGINE WILL BE USED.**

## BILGE CLEANING

The following steps should be performed to provide the watercraft enhanced protection.

Clean the bilge with hot water and detergent or with bilge cleaner. Rinse thoroughly. Lift front end of watercraft to completely drain bilge.

## Anticorrosion Treatment

Wipe off any residual water in the engine compartment.

Spray BOMBARDIER LUBE lubricant or equivalent over metallic components in engine compartment.



## WARNING

Do not lubricate the safety lanyard post.

Lubricate the throttle cable with BOMBARDIER LUBE lubricant or equivalent.

## Final Steps

If any repairs are needed to body or to the hull, contact your authorized Sea-Doo dealer. For paint touch up of mechanical parts use Bombardier spray paint.

Apply a good quality marine wax to the body. The seat and the seat extension should be partially left opened. This will prevent engine compartment condensation and possible corrosion.

If the watercraft is to be stored outside, cover it with an opaque tarpaulin to prevent sun rays and grime from affecting the plastic components, watercraft finish as well as preventing dust accumulation.

**CAUTION: The watercraft should never be left in water for storage. Never leave the watercraft stored in direct sunlight. Never store watercraft in a plastic bag.**

## Pre-Season Preparation

Use the following chart.

Since technical skills and special tools are required, some operations should be performed by an authorized Sea-Doo dealer.

### **WARNING**

Only perform procedures as detailed in this guide. It is recommended that the assistance of an authorized Sea-Doo dealer be periodically obtained on other components/ systems not covered in this guide. Unless otherwise specified, engine must not be running and the safety lanyard must be removed from its post for all maintenance procedures. Components inside engine compartment may be hot. When component conditions seem less than satisfactory, replace with genuine BOMBARDIER parts or approved equivalents.

## Pre-Season Preparation Chart

NOTE: It is highly recommended that an authorized Sea-Doo dealer perform the annual safety inspection and factory campaigns in addition to the pre-season preparation all at the same time.

	OPERATIONS	TO BE PERFORMED BY
<b>GENERAL</b>	Lubrication/corrosion protection	Customer
	Spark plug replacement ①	Dealer
<b>ENGINE</b>	Exhaust system condition and fasteners	Dealer
	Condition of seals and fasteners	Dealer
	Oil level	Dealer
<b>COOLING SYSTEM</b>	Inspection of cooling system coolant level, hoses and components If antifreeze was not changed for storage, drain and replace with new antifreeze.	Dealer
<b>FUEL SYSTEM</b>	Fuel filter replacement	Dealer
	Fuel injection sensors verification	Dealer
	Fuel system; check valves, lines, fasteners, pressurization ②	Dealer
	Filler neck, fuel tank and fuel cap condition ②	Dealer
	Fuel tank straps	Customer
	Refill fuel tank	Customer
<b>ELECTRICAL SYSTEM</b>	Battery condition/charging and reinstallation. Set the preferences in information center.	Dealer
	Battery, starter connections and routing ②	Dealer
	Monitoring beeper	Dealer
	Digitally encoded security system	Dealer
<b>STEERING SYSTEM</b>	Steering system adjustment/inspection ②	Dealer
<b>O.P.A.S. SYSTEM</b>	Check O.P.A.S. system condition including filter. Replace all 8 square rings.	Dealer
<b>PROPULSION SYSTEM</b>	SHIFTER SYSTEM CONDITION AND CABLE ADJUSTMENT	Dealer
	Propulsion system inspection	Dealer
<b>HULL AND BODY</b>	Inspection of bailer pick-ups	Dealer
	Ski/wake board post and fasteners	Customer

① Before installing new spark plugs, it is suggested to burn the excess BOMBARDIER LUBE lubricant or equivalent by starting the engine using the old spark plugs.

② Safety item covered in the annual safety inspection.

# TROUBLESHOOTING

The following chart is provided to help in diagnosing the probable source of simple troubles. You may be able to solve many of these problems rather quickly, but others may require the skills of a mechanical technician. In such cases, consult an authorized Sea-Doo dealer for servicing.

**NOTE:** For the definition of abbreviations used here, refer to ABBREVIATIONS USED IN THIS MANUAL section below.

## Monitoring Beeper Coded Signals

**NOTE:** When the beeper sounds, also look the message displayed on the information center to obtain more details on the problem. Refer to INFORMATION CENTER.

CODED SIGNALS	POSSIBLE CAUSE	REMEDY
2 short beeps (while installing safety lanyard on post).	<ul style="list-style-type: none"> <li>• Confirms safety lanyard signal operation.</li> </ul>	Engine can be started.
1 long beep (while installing safety lanyard on watercraft post).	<ul style="list-style-type: none"> <li>• Bad DESS system connection.</li> <li>• Wrong safety lanyard.</li> <li>• Defective safety lanyard.</li> <li>• Dried salt water in safety lanyard cap.</li> <li>• Defective DESS post.</li> <li>• Improper operation of EMS ECU or defective wiring harness.</li> </ul>	Reinstall safety lanyard cap correctly over post.  <b>USE A SAFETY LANYARD THAT HAS BEEN PROGRAMMED FOR THE WATERCRAFT.</b>  Use another programmed safety lanyard.  Clean safety lanyard cap to remove salt water.  Refer to an authorized Sea-Doo dealer.  Refer to an authorized Sea-Doo dealer.
1 short beep followed by 1 long beep.	<ul style="list-style-type: none"> <li>• EMS ECU has been inadvertently set to onboard diagnostic mode.</li> </ul>	Remove and reinstall safety lanyard.
4 short beeps every 3 seconds interval for 4 hours.	<ul style="list-style-type: none"> <li>• Safety lanyard has been left on its post without starting engine or after engine was stopped.</li> </ul>	To prevent battery discharge, remove the safety lanyard from its post.
A 2 seconds beep every minute interval.	<ul style="list-style-type: none"> <li>• High pressure in oil separator tank.</li> <li>• Low fuel level.</li> <li>• Fuel tank level sensor or circuit malfunction.</li> </ul>	Refer to an authorized Sea-Doo dealer.  Refer to an authorized Sea-Doo dealer.  Refer to an authorized Sea-Doo dealer.

CODED SIGNALS	POSSIBLE CAUSE	REMEDY
A 2 seconds beep every 15 minutes interval.	<ul style="list-style-type: none"> <li>• Watercraft is upside down.</li> <li>• Engine coolant temperature sensor or circuit malfunction.</li> <li>• Fuel level sensor or circuit malfunction.</li> <li>• Exhaust temperature sensor or circuit malfunction.</li> <li>• Engine oil pressure sensor or circuit malfunction.</li> <li>• Low pressure in oil separator tank (engine oil leak).</li> <li>• TOPS sensor or circuit malfunction.</li> <li>• TOPS valve solenoid or circuit malfunction.</li> <li>• EMS ECU failure.</li> <li>• Bilge pump circuit low or high voltage (if so equipped).</li> <li>• Starter solenoid circuit malfunction.</li> </ul>	<p>TURN WATERCRAFT UPRIGHT. REFER TO SPECIAL PROCEDURES.</p> <p>REFER TO AN AUTHORIZED SEA-DOO DEALER.</p> <p>REFER TO AN AUTHORIZED SEA-DOO DEALER.</p> <p>REFER TO AN AUTHORIZED SEA-DOO DEALER.</p> <p>REFER TO AN AUTHORIZED SEA-DOO DEALER.</p> <p>REFER TO AN AUTHORIZED SEA-DOO DEALER.</p> <p>REFER TO AN AUTHORIZED SEA-DOO DEALER.</p> <p>REFER TO AN AUTHORIZED SEA-DOO DEALER.</p> <p>REFER TO AN AUTHORIZED SEA-DOO DEALER.</p> <p>REFER TO AN AUTHORIZED SEA-DOO DEALER.</p> <p>REFER TO AN AUTHORIZED SEA-DOO DEALER.</p>
Continuously beeps.	<ul style="list-style-type: none"> <li>• High engine temperature coolant.</li> <li>• High exhaust temperature.</li> </ul>	<p>See engine OVERHEATING.</p> <p>REFER TO AN AUTHORIZED SEA-DOO DEALER.</p>

## Information Center Messages

OBSERVATION	POSSIBLE CAUSE	REMEDY
The information center display abbreviated messages that I don't understand.	<ul style="list-style-type: none"> <li>• Some messages are useful navigational information and others may be system fault information.</li> </ul>	Refer to INFORMATION CENTER in CONTROLS, COMPONENTS AND INSTRUMENTS FUNCTIONS.
No numbers are displayed in the usual display and only P-XXXX numbers appear in the message area.	<ul style="list-style-type: none"> <li>• EMS ECU has been inadvertently set to onboard diagnostic mode.</li> </ul>	Remove and reinstall safety lanyard.



## Engine Will Not Start

OTHER OBSERVATION	POSSIBLE CAUSE	REMEDY
Engine does not turn over.	<ul style="list-style-type: none"> <li>• Safety lanyard removed.</li> <li>• EMS ECU does not recognize the safety lanyard.</li> <li>• Turned over watercraft.</li> <li>• Burnt fuse: main, electric starter, MPEM or EMS ECU.</li> <li>• Discharged battery.</li> <li>• Battery connections, corroded or loose.</li> <li>• Water-flooded engine.</li> <li>• Faulty sensor, MPEM or EMS ECU.</li> <li>• Seized engine.</li> <li>• Seized jet pump.</li> </ul>	<p>Install cap over POST.</p> <p>REFER TO AN AUTHORIZED SEA-DOO DEALER.</p> <p>Refer to CAPSIZED WATERCRAFT in SPECIAL PROCEDURES.</p> <p>CHECK WIRING THEN REPLACE FUSE(S).</p> <p>REFER TO AN AUTHORIZED SEA-DOO DEALER.</p> <p>REFER TO AN AUTHORIZED SEA-DOO DEALER.</p> <p>Refer to WATER-FLOODED ENGINE in SPECIAL PROCEDURES.</p> <p>REFER TO AN AUTHORIZED SEA-DOO DEALER.</p> <p>REFER TO AN AUTHORIZED SEA-DOO DEALER.</p> <p>Try to clean. Otherwise, refer to an authorized Sea-Doo dealer.</p>
Engine turns slowly.	<ul style="list-style-type: none"> <li>• Loose battery cable connections.</li> <li>• Discharged or weak battery.</li> <li>• Worn starter.</li> </ul>	<p>Check/clean/tighten.</p> <p>REFER TO AN AUTHORIZED SEA-DOO DEALER.</p> <p>REFER TO AN AUTHORIZED SEA-DOO DEALER.</p>
Engine turns normally.	<ul style="list-style-type: none"> <li>• Fuel tank empty or water-contaminated.</li> <li>• Fouled/defective spark plugs.</li> <li>• Fuel-flooded engine.</li> <li>• Water-flooded engine.</li> <li>• Faulty component in the engine management system or faulty connection.</li> <li>• Disconnected or faulty fuel pump.</li> <li>• Blown fuse.</li> </ul>	<p>Refill. Siphon and fill with fresh fuel.</p> <p>Replace.</p> <p>Refer to FUEL-FLOODED ENGINE in SPECIAL PROCEDURES.</p> <p>Refer to WATER-FLOODED ENGINE in SPECIAL PROCEDURES.</p> <p>REFER TO AN AUTHORIZED SEA-DOO DEALER.</p> <p>Try reconnecting fuel pump connector. Refer to an authorized Sea-Doo dealer.</p> <p>CHECK WIRING THEN REPLACE FUSE(S).</p>

## Engine Misfires, Misinjects, Runs Irregularly

OTHER OBSERVATION	POSSIBLE CAUSE	REMEDY
Weak spark.	<ul style="list-style-type: none"> <li>Fouled/defective/worn spark plugs.</li> <li>Faulty ignition coil(s) or EMS ECU.</li> </ul>	<p>Replace.</p> <p>Refer to an authorized Sea-Doo dealer.</p>
Lean fuel mixture.	<ul style="list-style-type: none"> <li>Fuel: Level too low, stale or water-contaminated.</li> <li>Clogged injectors.</li> <li>Defective sensor or EMS ECU.</li> </ul>	<p>Siphon and/or refill.</p> <p>Refer to an authorized Sea-Doo dealer.</p> <p>Refer to an authorized Sea-Doo dealer.</p>
Rich fuel mixture (high fuel consumption).	<ul style="list-style-type: none"> <li>Defective sensor or EMS ECU.</li> </ul>	<p>Refer to an authorized Sea-Doo dealer.</p>

## Engine Smoke

OTHER OBSERVATION	POSSIBLE CAUSE	REMEDY
	<ul style="list-style-type: none"> <li>Oil level too high.</li> <li>Internal engine damage.</li> </ul>	<p>Refer to an authorized Sea-Doo dealer.</p> <p>Refer to an authorized Sea-Doo dealer.</p>

## Engine Overheats

OTHER OBSERVATION	POSSIBLE CAUSE	REMEDY
	<ul style="list-style-type: none"> <li>Engine coolant level too low.</li> <li>Clogged jet pump water intake.</li> <li>Clogged exhaust cooling system.</li> </ul>	<p>Refer to LIQUIDS.</p> <p>Clean.</p> <p>Flush exhaust cooling system.</p>
	<ul style="list-style-type: none"> <li>Quick connect adapter left in flushing connector.</li> </ul>	<p>Remove adapter from flushing connector and retry watercraft. If problem persists, refer to an authorized Sea-Doo dealer.</p>

## Engine Continually Backfires

OTHER OBSERVATION	POSSIBLE CAUSE	REMEDY
Weak spark.	<ul style="list-style-type: none"> <li>Fouled/defective/worn spark plugs.</li> </ul>	<p>Replace.</p>
Wrong spark.	<ul style="list-style-type: none"> <li>Ignition coils wrongly connected.</li> </ul>	<p>Refer to an authorized Sea-Doo dealer.</p>

## Engine Pinging or Knocking

OTHER OBSERVATION	POSSIBLE CAUSE	REMEDY
	<ul style="list-style-type: none"> <li>Knock sensor malfunction.</li> </ul>	<p>Refer to an authorized Sea-Doo dealer.</p>

## Engine Lacks Acceleration or Power

OTHER OBSERVATION	POSSIBLE CAUSE	REMEDY
	<ul style="list-style-type: none"> <li>• Engine oil level too high.</li> <li>• Weak spark.</li> <li>• The monitoring system put the watercraft in limp home mode due to a component malfunction.</li> <li>• Engine damaged by water ingestion.</li> <li>• Clogged injectors.</li> <li>• Low fuel pressure.</li> <li>• Water in fuel.</li> </ul>	<p>Refer to an authorized Sea-Doo dealer.</p> <p>Refer to ENGINE MISFIRES, RUNS IRREGULARLY.</p> <p>Refer to MONITORING SYSTEM in SPECIAL PROCEDURES.</p> <p>Refer to an authorized Sea-Doo dealer.</p> <p>Refer to an authorized Sea-Doo dealer.</p> <p>Refer to an authorized Sea-Doo dealer.</p> <p>Siphon and replace.</p>

## Watercraft Can Not Reach Top Speed

OTHER OBSERVATION	POSSIBLE CAUSE	REMEDY
Cavitation.	<ul style="list-style-type: none"> <li>• Jet pump water intake clogged.</li> <li>• Damaged impeller.</li> <li>• The SEA-DOO Learning Key™ safety lanyard is used which does not allow watercraft to reach its top speed.</li> <li>• The monitoring system put the watercraft in limp home mode due to a component malfunction.</li> </ul>	<p>Clean.</p> <p>Replace. Refer to an authorized Sea-Doo dealer.</p> <p>Use a regular safety lanyard.</p> <p>Refer to MONITORING SYSTEM in SPECIAL PROCEDURES.</p>
O.P.A.S.™ side vanes do not go up while watercraft is at speed.	<ul style="list-style-type: none"> <li>• CLOGGED FILTER, SQUARE RINGS DAMAGED, leakage in hoses or mechanical malfunction.</li> </ul>	Refer to an authorized Sea-Doo dealer.
O.P.A.S. side vanes do not go down while engine is at idle.	<ul style="list-style-type: none"> <li>• Broken spring inside side vane cylinder.</li> </ul>	Refer to an authorized Sea-Doo dealer.

## Engine RPM Gradually Decreases and Engine Stops

OTHER OBSERVATION	POSSIBLE CAUSE	REMEDY
	<ul style="list-style-type: none"> <li>• Out of fuel.</li> <li>• CPS sensor malfunction.</li> <li>• TOPS malfunction.</li> </ul>	<p>Refill.</p> <p>Refer to an authorized Sea-Doo dealer.</p> <p>Refer to an authorized Sea-Doo dealer.</p>

## O.P.A.S. System Faults

OTHER OBSERVATION	POSSIBLE CAUSE	REMEDY
Watercraft is more responsive than usual while turning.	<ul style="list-style-type: none"><li>• Side vanes do not go up while watercraft is at speed.</li></ul>	Refer to an authorized Sea-Doo dealer.
Watercraft pulls on one side.	<ul style="list-style-type: none"><li>• One side vane does not go up while watercraft is at speed.</li></ul>	Refer to an authorized Sea-Doo dealer.
O.P.A.S. side vanes do not go up while watercraft is at speed.	<ul style="list-style-type: none"><li>• Clogged filter, square rings damaged, leakage in hoses or mechanical malfunction.</li></ul>	Refer to an authorized Sea-Doo dealer.
O.P.A.S. side vanes do not go down while engine is at idle.	<ul style="list-style-type: none"><li>• Broken spring inside side vane cylinder.</li></ul>	Refer to an authorized Sea-Doo dealer.

## Abnormal Noise from Propulsion System

OTHER OBSERVATION	POSSIBLE CAUSE	REMEDY
Cavitation.	<ul style="list-style-type: none"><li>• Weeds or debris jammed around impeller.</li><li>• Damaged impeller shaft or drive shaft.</li><li>• Water intrusion in jet pump causing bearing seizure.</li></ul>	Clean and check for damage.  Refer to an authorized Sea-Doo dealer.  Refer to an authorized Sea-Doo dealer.

# SPECIFICATIONS

<b>ENGINE</b>		<b>GTX 4-TEC SERIES (6105/6106/6107/6108/6111/6112/ 6125/6126/6128/6129)</b>
Type	BOMBARDIER-ROTAX 1503, 4 stroke. Single Over Head Camshaft (SOHC), liquid cooled	
Number of cylinder	3 in line	
Number of valve	12 valves (4 per cylinder) with hydraulic lifters (no adjustment)	
Displacement	1494 cc (91.2 cu. in)	
Induction type	<b>GTX 4-TEC and GTX 4-TEC Vans Triple Crown Edition:</b> Normally-aspirated <b>GTX 4-TEC Supercharged, GTX 4-TEC Supercharged Limited:</b> Mechanically- driven supercharger	
Bore	100 mm (3.9 in)	
Stroke	63.4 mm (2-1/2 in)	
Compression ratio	10.5:1	
Lubrication	Type	Dry sump (2 oil pumps). Replaceable oil filter. Water-cooled oil cooler
	Oil type	4-stroke engine oil SAE 10W40 (API service classification SG, SH or SJ)
Exhaust system	Water cooled/water injected. Direct flow from propulsion unit	
Rev limiter setting	7300 ± 50 RPM	
<b>COOLING SYSTEM</b>		
Type	Liquid cooled. Closed circuit (see also exhaust system)	
Coolant	Ethylene-glycol 50%/50% antifreeze/water. Coolant containing corrosion inhibitors for internal combustion aluminum engines	

<b>ELECTRICAL SYSTEM</b>		<b>GTX 4-TEC SERIES (6105/6106/6107/6108/6111/6112/ 6125/6126/6128/6129)</b>
Magneto generator output		360 W @ 6000 RPM
Ignition system type		Digital inductive type
Ignition timing		Not adjustable
Spark plug	Make and type	NGK, DCPR8ES
	Gap	0.75 mm (.030 in)
	Quantity	3
Starting system		Electric starter
Battery		12 V, 30 A•h. Electrolyte type.
Fuse	TOPS	10 A
	Cylinder 1, ignition coil and injection	10 A
	Cylinder 2, ignition coil and injection	10 A
	Cylinder 3, ignition coil and injection	10 A
	Electric bilge pump (optional)	3 A
	Starting system, electric fuel pump	10 A
	EMS, start/stop circuit	5 A
	Main	2 x 30 A
	MPEM	2 A
	Depth gauge	2 A
	Charging system	20 A
	Information center	1 A
<b>FUEL SYSTEM</b>		
Fuel type	<p><b><i>Normally-Aspirated Models</i></b> Regular unleaded gasoline with 87 octane (Ron + Mon)/2 specification</p> <p><b><i>Supercharged Models</i></b> Recommended: Premium unleaded gasoline with 91 octane (Ron + Mon)/2 specification for optimum performance</p> <p>Minimum: Regular unleaded gasoline with 87 octane (Ron + Mon)/2 specification</p>	
Fuel injection	Rotax EMS (engine management system). Multipoint Fuel Injection. Single throttle body (52 mm (2.04 in))	

<b>PROPULSION</b>	<b>GTX 4-TEC SERIES (6105/6106/6107/6108/6111/6112/ 6125/6126/6128/6129)</b>
Propulsion system	Bombardier Formula pump
Jet pump type	Axial flow, single stage. Greased bearings
Transmission	Direct drive
Reverse system	Yes
O.P.A.S. system	Yes
Pivoting angle of direction (nozzle)	~ 20°
Minimum required water level for jet pump	90 cm (3 ft) underneath the lowest rear portion of hull
<b>DIMENSIONS</b>	
Number of passengers ①	3
Overall length	331 cm (130 in)
Overall width	122 cm (48 in)
Overall height	113 cm (44 in)
Weight	GTX 4-TEC and GTX 4-TEC Vans Triple Crown Edition 397 kg (875 lb) GTX 4-TEC Supercharged and GTX 4-TEC Supercharged Limited: 408 kg (900 lb)
Load limit (passengers + luggage)	272 kg (600 lb)
<b>CAPACITIES</b>	
Engine oil	3 L (2.7 U.S. qt) oil change w/filter 4.5 L (4.1 U.S. qt) total
Cooling system (coolant)	5.5 L (5 U.S. qt) total
Fuel tank (including reserve)	60 L (15.3 U.S. gal)
Fuel tank reserve (from low level signal)	9.8 L (2.6 U.S. gal)

N.A.: Not applicable

① Refer to load limit.

BOMBARDIER INC. reserves the right to make changes in design and specifications and/or to make additions to, or improvements in its products without imposing any obligation upon itself to install them on its products previously manufactured.

# SI\* METRIC INFORMATION

## BASE UNITS

DESCRIPTION	UNIT	SYMBOL
length.....	meter.....	m
mass.....	kilogram.....	kg
force.....	newton.....	N
liquid.....	liter.....	L
temperature.....	Celsius.....	°C
pressure.....	kilopascal.....	kPa
torque.....	newton-meter.....	N•m
land velocity.....	kilometer per hour.....	km/h
navigation velocity.....	knot.....	kn

## PREFIXES

PREFIX	SYMBOL	MEANING	VALUE
kilo.....	k.....	one thousand.....	1000
centi.....	c.....	one hundredth of.....	0.01
milli.....	m.....	one thousandth of.....	0.001
micro.....	μ.....	one millionth of.....	0.000001

## CONVERSION FACTORS

TO CONVERT	TO ①	MULTIPLY BY
in.....	mm.....	25.4
in.....	cm.....	2.54
in <sup>2</sup> .....	cm <sup>2</sup> .....	6.45
in <sup>3</sup> .....	cm <sup>3</sup> .....	16.39
ft.....	m.....	0.3
oz.....	g.....	28.35
lb.....	kg.....	0.45
lbf.....	N.....	4.4
lbf•in.....	N•m.....	0.11
lbf•ft.....	N•m.....	1.36
lbf•ft.....	lbf•in.....	12
PSI.....	kPa.....	6.89
imp. oz.....	U.S. oz.....	0.96
imp. oz.....	mL.....	28.41
imp. gal.....	U.S. gal.....	1.2
imp. gal.....	L.....	4.55
U.S. oz.....	mL.....	29.57
U.S. gal.....	L.....	3.79
U.S. quart.....	L.....	0.95
knot.....	MPH.....	1.15
MPH.....	km/h.....	1.61
Fahrenheit.....	Celsius.....	(°F - 32) ÷ 1.8
Celsius.....	Fahrenheit.....	(°C x 1.8) + 32
hp.....	kW.....	.75

\* The international system of units abbreviates SI in all languages.

① To obtain the reverse sequence, divide by the given factor. Example: to convert millimeters to inches, divide by 25.4.

NOTE: Conversion factors are rounded off to 2 decimals for easier use.



---

## ABBREVIATIONS USED IN THIS MANUAL

	DESCRIPTION
AC	Alternate current
API	American petroleum institute
CARB	California air resource board
DC	Direct current
DESS	Digitally encoded security system
EMS	Engine management system
EMS ECU	EMS Electronic control unit
E.I.N.	Engine identification number
EPA	Environmental protection agency
HP	Horse power
LCD	Liquid Crystal Display
LED	Light-emitting diode
MAG	Magneto
MPEM	Multi-purpose electronic module
MPH	Mile per hour
N.A.	Not applicable
O.P.A.S.	Off-power assisted steering
OPT	Optional
PFD	Personal flotation device
P/N	Part number
PTO	Power take off
STD	Standard
TBD	To be determined
TDC	Top dead center
T.O.P.S.	Tip-over protection system

---

# **PRIVACY INFORMATION**

We wish to inform you that your coordinates will be used for safety and warranty purposes. Sometimes, we also use the coordinates of our clients to inform them about our products and to present them offers. Should you prefer not to receive information on our products, services and offers, please let us know by writing to the address below.

Also note that, from time to time, carefully selected and trustworthy organizations may be permitted to use the coordinates of our clients to promote quality products and services. If you prefer not to have your name and address released, please let us know by writing to the address below:

**BOMBARDIER INC.  
RECREATIONAL PRODUCTS  
WARRANTY DEPARTMENT  
75, J.A. BOMBARDIER STREET  
SHERBROOKE, QUÉBEC  
CANADA J1L 1W3  
FAX NUMBER (819) 566-3590**

**CHANGE OF ADDRESS**

If your address has changed, be sure to fill out and mail the card provided on this page. Such notification is likewise necessary for your own safety even after expiration of the original warranty, since Bombardier will be in a position to contact you if correction to your watercraft becomes necessary.

**NOTE:** This card is strictly for change of address only.

**CHANGE OF ADDRESS**



CHANGE OF ADDRESS

**WATERCRAFT IDENTIFICATION NUMBERS**

Watercraft identification grid with 15 columns for Model Number and 15 columns for Hull Identification Number.

**Model Number**

**Hull Identification Number (H.I.N.)**

OLD ADDRESS: \_\_\_\_\_  
NAME

NO. STREET APT

CITY STATE/PROVINCE ZIP/POSTAL CODE

NEW ADDRESS: \_\_\_\_\_  
NAME

NO. STREET APT

CITY STATE/PROVINCE ZIP/POSTAL CODE

**STOLEN UNITS**

In the event that your watercraft is stolen, you should notify your area’s distributor warranty department of such.

Please provide your name, address, phone number, Hull Identification Number and date it was stolen.

Bombardier will provide a list of stolen units to all authorized Sea-Doo dealers on a monthly basis to aid in recovery of such units to their owners.



AFFIX  
PROPER  
POSTAGE

**BOMBARDIER**  
RECREATIONAL PRODUCTS  
WARRANTY DEPARTMENT  
75, J.A. BOMBARDIER ST.  
SHERBROOKE (QUEBEC)  
CANADA J1L 1W3

---

## CHANGE OF ADDRESS

If your address has changed, be sure to fill out and mail the card provided on this page.

Such notification is likewise necessary for your own safety even after expiration of the original warranty, since Bombardier will be in a position to contact you if correction to your watercraft becomes necessary.

**NOTE:** This card is strictly for change of address only.

## CHANGE OF ADDRESS



CHANGE OF ADDRESS

WATERCRAFT IDENTIFICATION NUMBERS

--	--	--	--	--	--	--	--	--	--	--	--	--	--	--	--	--	--	--	--	--	--	--

Model Number

Hull Identification Number (H.I.N.)

OLD ADDRESS: \_\_\_\_\_  
NAME

\_\_\_\_\_  
NO. STREET APT

\_\_\_\_\_  
CITY STATE/PROVINCE ZIP/POSTAL CODE

NEW ADDRESS: \_\_\_\_\_  
NAME

\_\_\_\_\_  
NO. STREET APT

\_\_\_\_\_  
CITY STATE/PROVINCE ZIP/POSTAL CODE

### STOLEN UNITS

In the event that your watercraft is stolen, you should notify your area's distributor warranty department of such.

Please provide your name, address, phone number, Hull Identification Number and date it was stolen.

Bombardier will provide a list of stolen units to all authorized Sea-Doo dealers on a monthly basis to aid in recovery of such units to their owners.



AFFIX  
PROPER  
POSTAGE

**BOMBARDIER**  
RECREATIONAL PRODUCTS  
WARRANTY DEPARTMENT  
75, J.A. BOMBARDIER ST.  
SHERBROOKE (QUEBEC)  
CANADA J1L 1W3

**WATERCRAFT** MODEL No. \_\_\_\_\_

**HULL**  
IDENTIFICATION NUMBER (H.I.N.) \_\_\_\_\_

**ENGINE**  
IDENTIFICATION NUMBER (E.I.N.) \_\_\_\_\_

**Owner:**

**Purchase Date** \_\_\_\_\_  
  |                  |                  |  
  YEAR      MONTH      DAY

**Warranty Expiry Date** \_\_\_\_\_  
  |                  |                  |  
  YEAR      MONTH      DAY

To be completed by the authorized Sea-Doo dealer at the time of the sale.

DEALER IMPRINT AREA

Please verify with your selling dealer to ensure your SEA-DOO watercraft has been registered with Bombardier.

