

SEA·200

Operator's Guide Supplement 2002



™® Trademarks of Bombardier Inc. or its subsidiaries.
© 2001 Bombardier Inc. All rights reserved.
Printed in Canada.

*Marque de commerce Bombardier Inc. et/ou de ses filiales.
© 2001 Bombardier Inc. Tous droits réservés.
Imprimé au Canada.

**This supplement must be used in
conjunction with 2002 *Operator's
Guide* (P/N 219 000 145).**

WARNING

**Read this guide thoroughly.
It contains important safety information.**

GTX DI

2 1 9 0 0 0 1 5 1



SAFETY WARNING

Disregarding any of the safety precautions and instructions contained in this *Operator's Guide*, the *Safety Handbook*, the *Safety Videocassette* and on the on-product warning labels could cause injury, including the possibility of death. The operator has the responsibility to inform passenger(s) of safety precautions.

This *Operator's Guide*, the *Safety Handbook* and *Safety Videocassette* should remain with the craft at the time of resale.

BOMBARDIER
RECREATIONAL PRODUCTS



GTX[†] is a trademark of Castrol Ltd. Used under license

The following trademarks are the property of Bombardier Inc. or its subsidiaries:

SEA-DOO®

BOMBARDIER-ROTAX®

ROTAX®

BOMBARDIER LUBE®

BOMBARDIER Formula XP-S DI Synthetic Injection Oil

NOTE

Dear 2002 GTX DI watercraft owner. Informations on the RX DI model in the *2002 Operator's Guide* (P/N 219 000 145) apply to your GTX DI except for the following.

TABLE OF CONTENTS

NOTE	1
TABLE OF CONTENTS	2
LOCATION OF THE IMPORTANT LABELS	3
LOCATION OF CONTROLS, COMPONENTS AND INSTRUMENTS	4
FUNCTIONS OF CONTROLS, COMPONENTS AND INSTRUMENTS	5
4) Engine Start/Stop Button	5
5) Variable Trim System Button (VTS)	5
6) Variable Trim System Gauge (VTS)	5
12) Information Center Gauge/Buttons	5
13) Glove Box.....	6
17) Front Storage Compartment Cover.....	6
21) Tool Kit	7
24) Seat Latch	7
25) Seat Extension Latch	7
27) Rear Storage Basket	8
34) Boarding Step	8
35) Cooling System Bleed Outlet.....	9
42) Fuses	9
43) Battery	9
44) Side Vanes	9
OPERATING INSTRUCTIONS	10
SPECIAL PROCEDURES	10
Towing the Watercraft in Water	10
MAINTENANCE	11
Fuses.....	11
TRAILERING, STORAGE AND PRE-SEASON PREPARATION	13
Storage	13
SPECIFICATIONS	17

LOCATION OF THE IMPORTANT LABELS

GTX DI Model



F18L03L

TYPICAL

GTX DI Model Only

The location of this label differs on the GTX DI model.

Label 6

• WARNING

DO NOT BOOST BATTERY
WHILE INSTALLED.

F00L050

Label 14

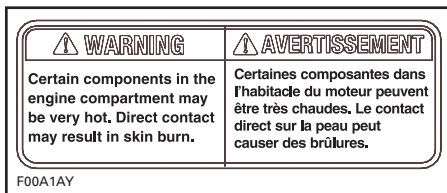

LOCATION OF CONTROLS, COMPONENTS AND INSTRUMENTS

GTX DI Model

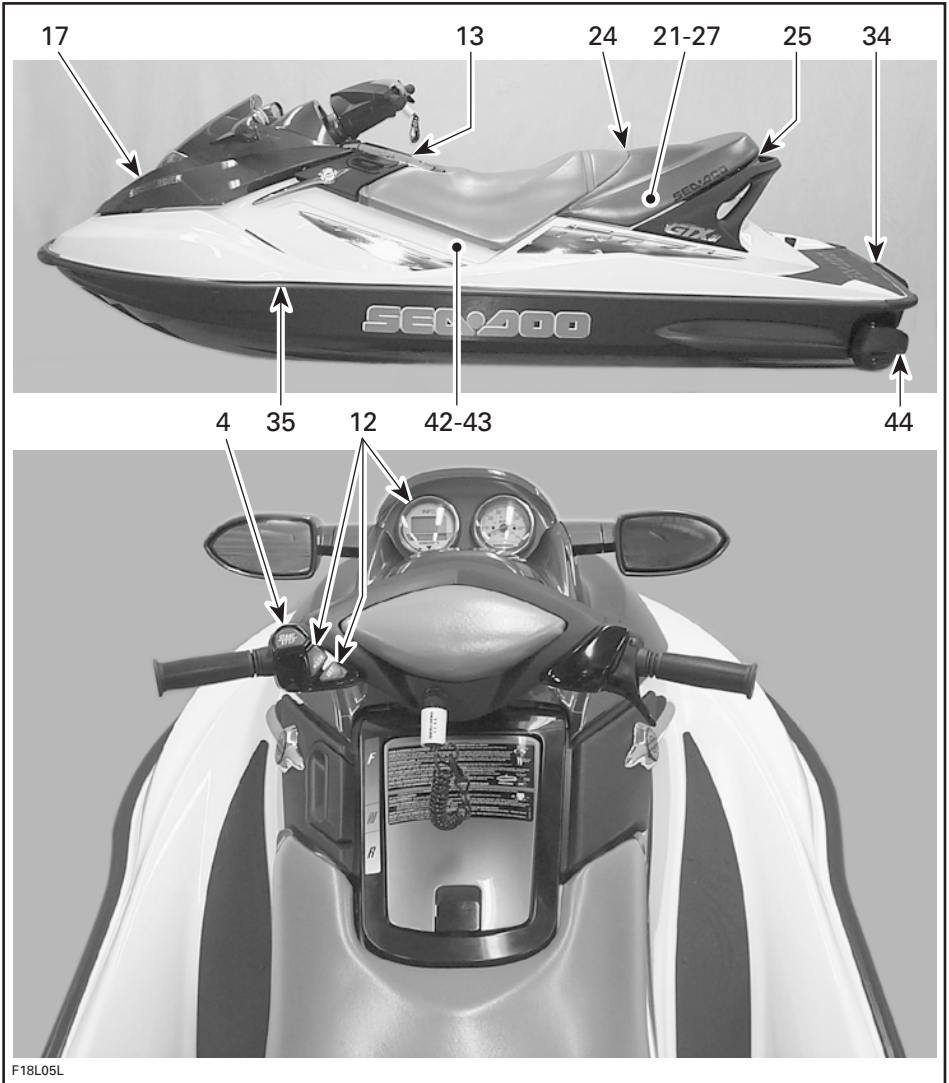

- 4. Engine Start/Stop Button
- 12. Information Center Gauge/Buttons
- 13. Glove Box
- 17. Front Storage Compartment Cover
- 21. Tool Kit
- 24. Seat Latch
- 25. Seat Extension Latch
- 27. Rear Storage Basket
- 34. Boarding Step
- 35. Cooling System Bleed Outlet
- 42. Fuses
- 43. Battery
- 44. Side Vanes

NOTE: Some components shown in the *2002 Sea-Doo Operator's Guide* do not apply to this watercraft.

FUNCTIONS OF CONTROLS, COMPONENTS AND INSTRUMENTS

4) Engine Start/Stop Button

It is the same operation as explained in the *2002 Operator's Guide*. Only the shape and arrangement differ. Refer to the following updated illustration.

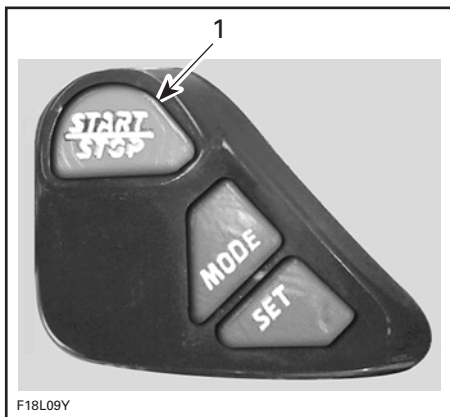

1. Start/Stop button

5) Variable Trim System Button (VTS)

There is no VTS on the GTX DI model.

6) Variable Trim System Gauge (VTS)

There is no VTS on the GTX DI model.

12) Information Center Gauge/Buttons

It is the same operation as explained in the *2002 Operator's Guide*. Only the location differs. Refer to LOCATION OF CONTROLS, COMPONENTS AND INSTRUMENTS section and the following updated text and illustrations.

Gauge Description

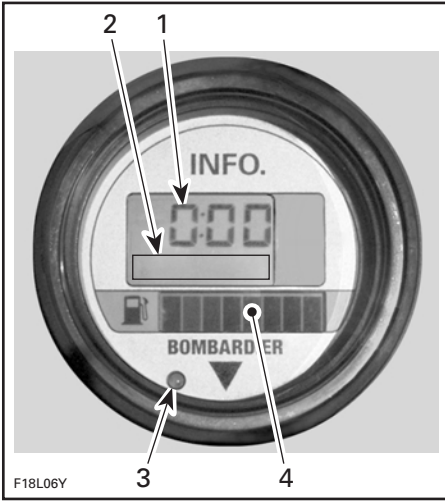

1. General display
2. Message/units display
3. Warning light
4. Fuel level display

Function Buttons

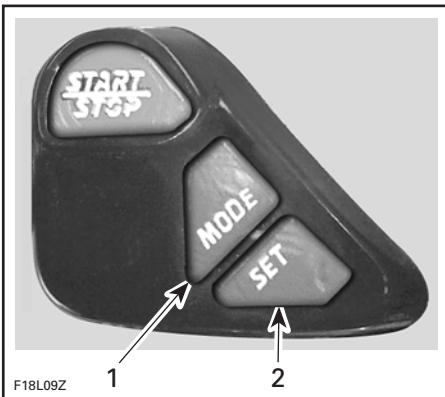

1. To change display mode
2. To set or reset a function

13) Glove Box

It is the same operation as explained in the *2002 Operator's Guide*. Only the location differs. Refer to LOCATION OF CONTROLS, COMPONENTS AND INSTRUMENTS section.

17) Front Storage Compartment Cover

Refer to the following updated text and illustrations.

It gives access to the front storage compartment. Always relatch cover after closing.

Front Storage Compartment

A convenient watertight area to carry personal articles. Ideal location for tow-rope, first aid kit, etc.

WARNING

Never leave any heavy or breakable objects loose in the storage area. Never operate the watercraft with any storage compartment cover open.

If there is water in the storage area, pull out the drain plug to let water go out. Reinstall the plug when done.

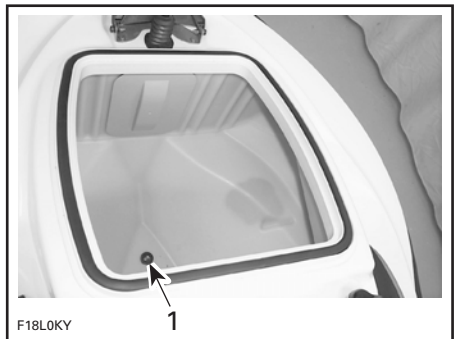

1. Drain plug

NOTE: The water will flow to the bilge. If there is an important quantity of water, ensure to drain the bilge (out of water) prior to using the watercraft.

The front storage area includes a latch to hold an approved fire extinguisher (sold separately).

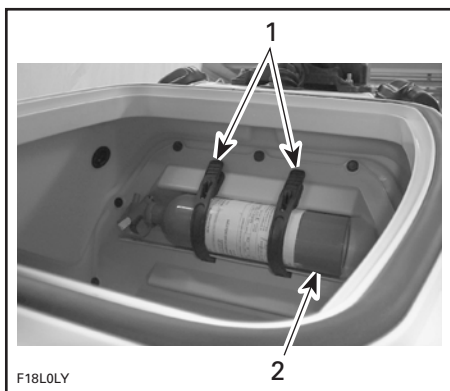

1. Retaining straps
2. Extinguisher (sold separately)

WARNING

Ensure to properly secure extinguisher with the supplied retaining straps.

21) Tool Kit

It is the same information as explained in the *2002 Operator's Guide*. Only the location differs. Refer to LOCATION OF CONTROLS, COMPONENTS AND INSTRUMENTS section.

24) Seat Latch

It is the same operation as explained in the *2002 Operator's Guide* for 3-up seat models. Refer to the following updated illustration.

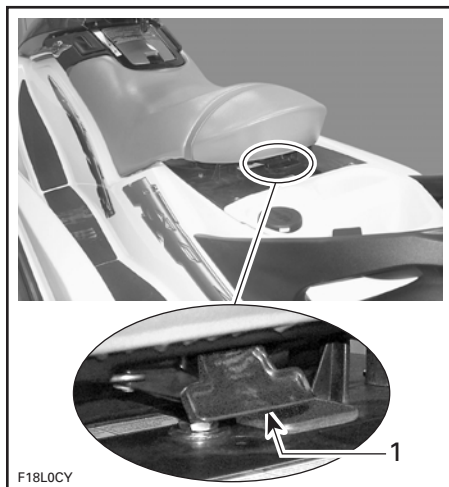

1. Seat latch

25) Seat Extension Latch

It is the same operation as explained in the *2002 Operator's Guide* for 3-up seat models. Refer to the following updated illustration.

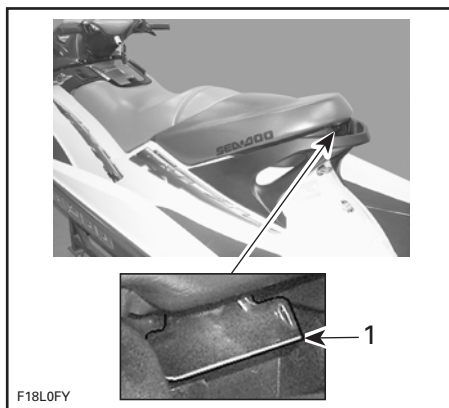

1. Seat extension latch

27) Rear Storage Basket

It is the same operation as explained in the *2002 Operator's Guide* for **3-up seat models**. Refer to the following updated illustration.

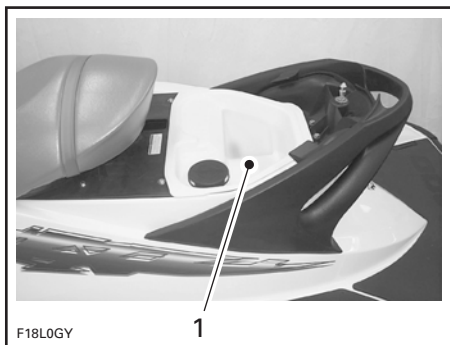

1. Rear storage basket

Spare Spark Plug Holder

The storage basket features a spare spark plug holder.

To keep spare spark plugs dry and prevent shocks that might affect the adjustment or break them, a holder is provided.

Unscrew cap counterclockwise to expose the holder and insert spark plug in their holes. Reinstall cap.

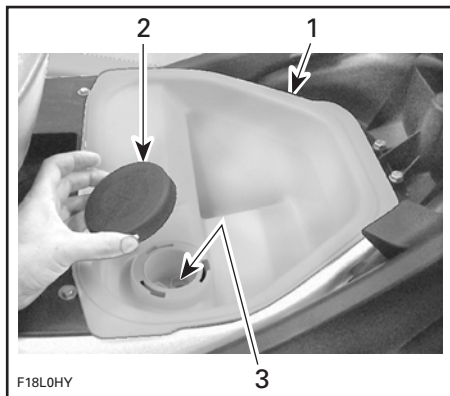

1. Storage basket
2. Spare spark plug holder cap
3. Spark plug holder

NOTE: Adjust spare spark plug gap according to SPECIFICATIONS before installation.

NOTE: Spare spark plugs are not supplied with the watercraft.

34) Boarding Step

It is the same operation as explained in the *2002 Operator's Guide* for **some models**. Refer to the following updated illustrations.

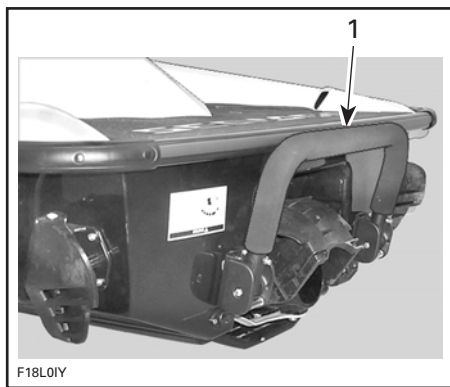

1. Boarding step

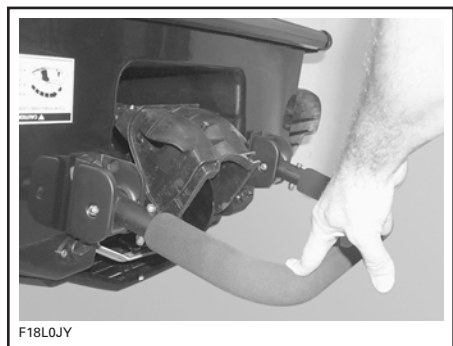

35) Cooling System Bleed Outlet

It is the same operation as explained in the *2002 Operator's Guide*. Only the location differs. Refer to LOCATION OF CONTROLS, COMPONENTS AND INSTRUMENTS section.

42) Fuses

It is the same information as explained in the *2002 Operator's Guide*. The location and the description differ. Refer to LOCATION OF CONTROLS, COMPONENTS AND INSTRUMENTS section and the following updated illustrations.

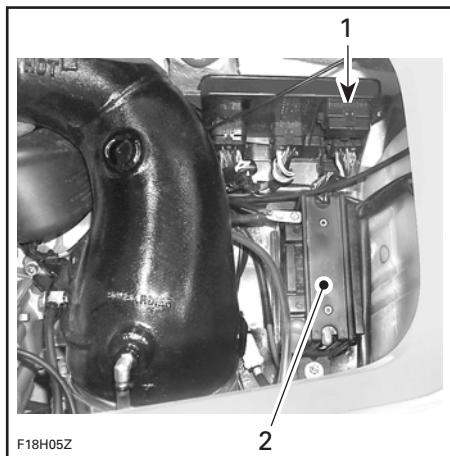

FUSES AND BATTERY LOCATION IN BILGE

1. Fuses
2. Battery

43) Battery

It is the same information as explained in the *2002 Operator's Guide*. Only the location differs. Refer to LOCATION OF CONTROLS, COMPONENTS AND INSTRUMENTS section. See illustration above.

44) Side Vanes

It is the same operation as explained in the *2002 Operator's Guide* for **some models**. Refer to LOCATION OF CONTROLS, COMPONENTS AND INSTRUMENTS section.

The **GTX DI model** is equipped with the O.P.A.S.™ (Off-Power Assisted Steering). Ensure to read all information in the *2002 Operator's Guide* (P/N 219 000 145) that pertains to this system.

OPERATING INSTRUCTIONS

For the GTX DI model, follow the instructions given for the GTX series and 3-up seat models in the *2002 Operator's Guide* (P/N 219 000 145).

SPECIAL PROCEDURES

Towing the Watercraft in Water

It is the same as explained in the *2002 Operator's Guide*. Only the hose routing differs. Refer to the following updated illustration.

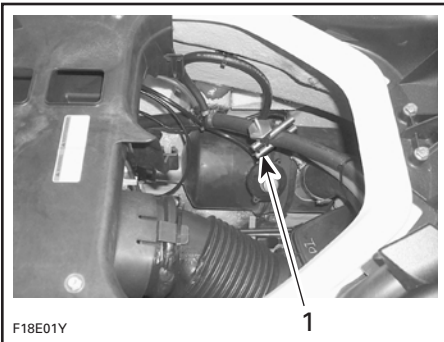

GTX DI MODEL

1. *Hose pincher on water supply hose on this side of the T-fitting*

CAUTION: When finished towing the watercraft, hose pincher should be removed before operating it. Failure to do so will result in damage to the engine.

MAINTENANCE

Fuses

It is the same information as explained in the *2002 Operator's Guide* except for the following. Refer to the updated text and illustrations.

MPEM

To access fuses on the MPEM, remove seat.

Locate MPEM besides engine.

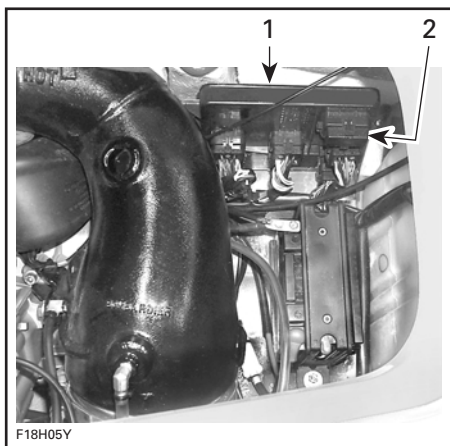

1. MPEM
2. Fuses location

Fuses are identified, look above and besides the fuse holder.

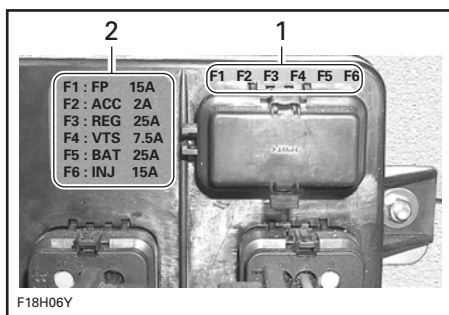

FUSE IDENTIFICATION

1. Fuse identification
2. Fuse description

Fuse identification: The fuses (F) are identified from 1 to 6.

Fuse description: The fuses are described with abbreviation as follows:

FP: Fuel pump

ACC: Accessories (information center)

REG: Regulator (charging system)

VTS: Variable Trim System. Fuse is installed but not in use on the GTX DI model

BAT: Battery

INJ: Injection system

The fuse description is followed by the ampere rating (A).

Rear Electrical Box

Remove seat.

Locate electrical box at the back of the bilge.

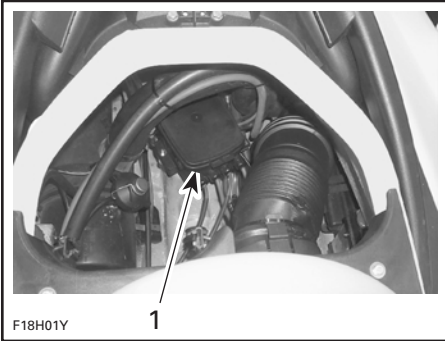

1. Electrical box

Unclip and remove cover of the electrical box to expose the holder of the main fuse.

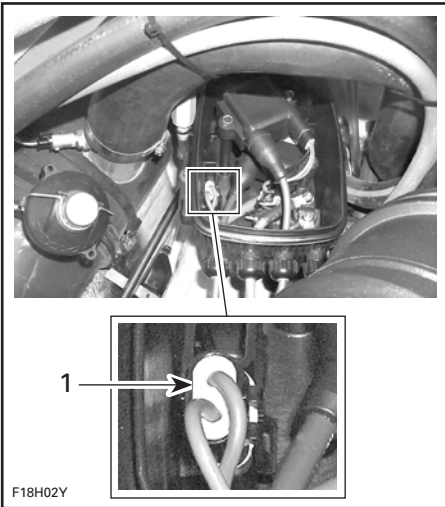

TYPICAL

1. Fuse holder

Properly reinstall removed components.

TRAILERING, STORAGE AND PRE-SEASON PREPARATION

It is the same information as explained in the *2002 Operator's Guide* except for the following updated illustrations.

Storage

Engine Draining

Check engine drain hose (lowest hose of engine). Make sure there is no sand or other particles in it and that it is not obstructed so that water can exit the engine. Clean hose and fitting as necessary.

CAUTION: Water in engine drain hose should be free to flow out, otherwise water could be trapped in engine. Should water freeze in engine, severe damage will occur. Check engine drain hose for obstructions.

Disconnect the quick connect fitting. Press both tabs and pull fitting.

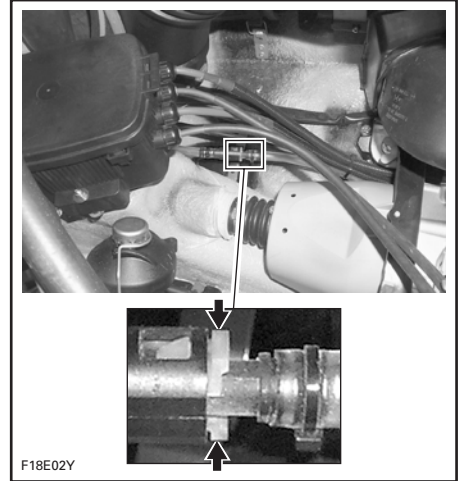

DISCONNECT THIS HOSE

Lower hose as necessary so that draining can take place.

Reconnect fitting when done.

Also ensure air compressor drain line is not obstructed. Clean as necessary.

Antifreezing Protection

NOTE: This procedure requires approximately 2.5 L (2.6 U.S. qt.) of antifreeze.

In cool regions where freezing point may be encountered, cooling system should be filled with an equal part of water and antifreeze solution.

CAUTION: Antifreeze mix must be fed in cooling system. Otherwise remaining water will freeze. This operation requires a good technical knowledge of the cooling system path. If antifreezing is not performed adequately engine/exhaust system may freeze and cause severe engine damage. We strongly recommend this operation be performed by an authorized SEA-DOO dealer.

CAUTION: Always use ethylene glycol antifreeze containing corrosion inhibitors specifically recommended for aluminum engines.

NOTE: When available, it is recommended to use biodegradable antifreeze compatible with internal combustion aluminum engines. This will contribute to protect the environment.

NOTE: The engine will not have to run during this operation but should have been ran before, to exhaust as much water as possible, from cooling system components.

NOTE: It may be easier to reach hoses when you remove the seat opening bridge.

Hose Pinchers Installation

Some hoses have to be plugged to prevent draining, before filling cooling system jackets with the antifreeze.

Install hose pinchers at the following location:

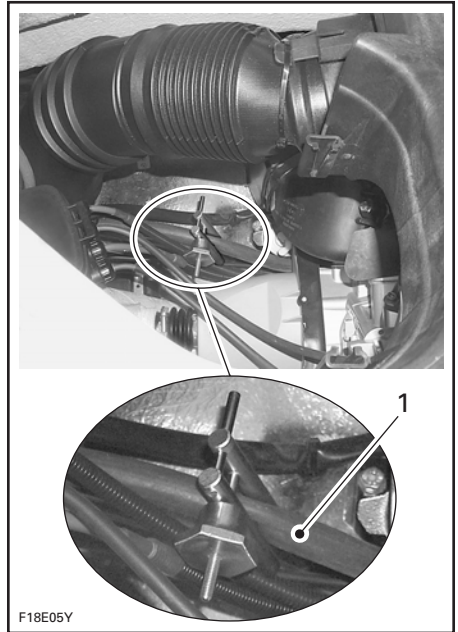

1. Water outlet hose

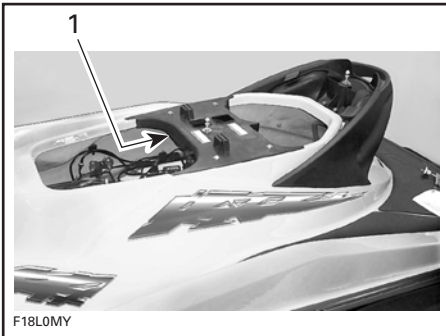

1. Seat opening bridge

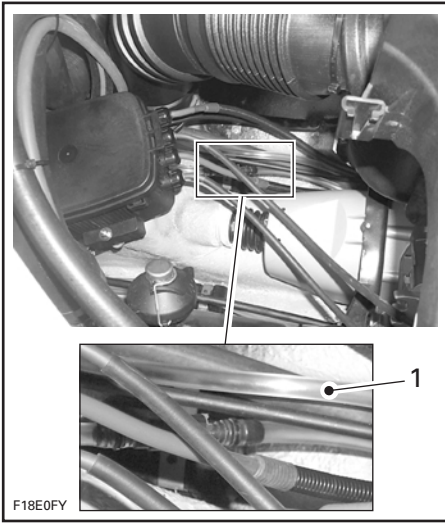

1. Crankcase cooling cover outlet hose

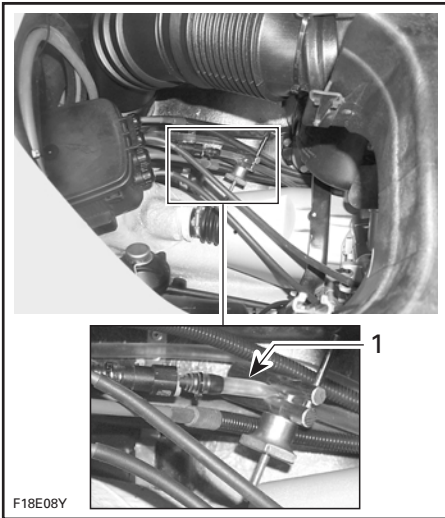

1. Engine cylinder drain hose

Hose Disconnection

Disconnect water **INLET** hose at engine between T-fitting and cylinder head fitting.

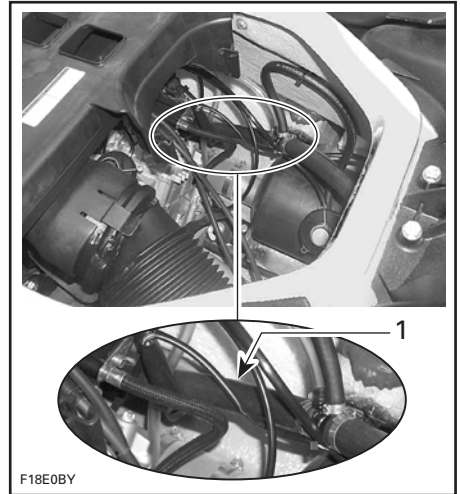

1. Disconnect this side of the T-fitting

Temporarily install a short piece of hose to replace the one removed.

Antifreeze

Insert a funnel into the temporary hose and pour antifreeze mix in engine until the colored solution appears at cooling system bleed outlet.



TYPICAL

At this point, install a hose pincher on bleed outlet hose.

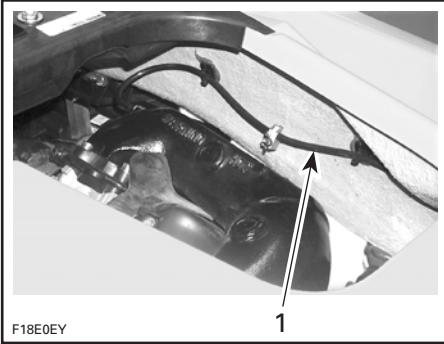

1. Bleed outlet hose

Continue to pour until antifreeze flows in air compressor water outlet hose.

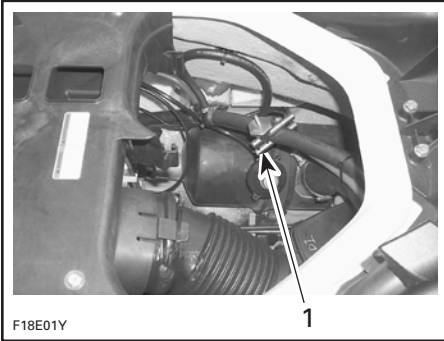

1. Air compressor water outlet hose

Remove pinchers in this order to allow proper flow of antifreeze.

1. Bleed outlet hose.
2. Crankcase cooling cover outlet hose.
3. Engine cylinder drain hose.
4. Water outlet hose.

Pour approximately 200 mL (7 oz) of antifreeze in the water regulator valve supply hose to allow antifreeze flowing through the valve and into muffler to protect it.

Remove temporary hose and reconnect engine water outlet hose.

Most of the antifreeze will drain out when removing the hose pinchers. Use a container to recover it. **DISPOSE ANTIFREEZE AS PER YOUR LOCAL LAWS AND REGULATIONS.**

NOTE: Although antifreeze will mainly drain out, the antifreeze has mixed with the water that was possibly trapped in the water jackets and thus preventing freezing problems.

At pre-season preparation, drain the remaining antifreeze from cooling system prior to using the watercraft.

The following steps should be performed to provide the watercraft enhanced protection.

Clean the bilge with hot water and detergent or with bilge cleaner. Rinse thoroughly. Lift front end of watercraft to completely drain bilge. If any repairs are needed to body or to the hull contact your authorized SEA-DOO dealer. For paint touch up to mechanical parts use Bombardier spray paint.

Reinstall vent tube support.

SPECIFICATIONS

ENGINE		GTX DI (5563/5564/5595/5596)
Engine type		Rotax® 947, 2-stroke
Induction type		Reed valve
Exhaust system		Water cooled/water injected
Exhaust valve		Rotax Adjustable Variable Exhaust (RAVE)
Lubrication	Type	Oil injection
	Oil type	BOMBARDIER Formula XP-S DI synthetic injection oil (or equivalent)
Number of cylinders		2
Displacement		951.2 cm ³ (58 in ³)
COOLING		
Type		Open circuit. Direct flow from propulsion unit
ELECTRICAL		
Magneto generator output		200 W @ 6000 RPM
Ignition system type		Digital CDI
Spark plug	Make and type	NGK, ZFR4F
	Gap	1.1 mm (.043 in)
Starting system		Electric starter with reduction gear
Battery		12 V, 19 A•h
Fuse	Battery	25 A
	Main	30 A
	Charging system (REG)	25 A
	VTS system	Installed but not in use
	Information center (ACC)	2 A
	Injection system (INJ)	15 A
	Fuel pump (FP)	15 A
CARBURETION		
Fuel type		Regular gasoline with 87 octane minimum (R+M)/2
Fuel injection		Orbital direct fuel injection, twin throttle body (46 mm (1.81 in))

PROPULSION		GTX DI (5563/5564/5595/5596)
Propulsion system		Bombardier Formula pump
Jet pump type		Axial flow, single stage
Transmission		Direct drive
Reverse system		Yes
Jet pump oil type		SEA-DOO synthetic polyolester oil SAE 75W90 GL5
Minimum required water level for jet pump		90 cm (3 ft)
DIMENSIONS		
Number of passengers ①		3
Overall length		331 cm (130 in)
Overall width		122 cm (48 in)
Overall height		113 cm (44 in)
Weight		320 kg (705 lb)
Load limit (passengers + luggage)		272 kg (600 lb)
CAPACITIES		
Fuel tank (including reserve)		56.5 L (15 U.S. gal)
Fuel tank reserve (from low level signal on DI models)		9.8 L (2.6 U.S. gal)
Oil injection tank		6 L (1.6 U.S. gal)
Impeller shaft reservoir	Capacity	115 mL (3.9 U.S. oz)
	Oil level	Up to plug

① Refer to load limit.

BOMBARDIER INC. reserves the right to make changes in design and specifications and/or to make additions to, or improvements in its products without imposing any obligation upon itself to install them on its products previously manufactured.