

SEA-DOO®



Operator's
GUIDE
Supplement

1998



219 000 078

SEA-DOO GTX RFI (5666/5843) OPERATOR'S GUIDE SUPPLEMENT

This *Operator's Guide Supplement* contains information specifically applicable to the GTX RFI (5666/5843) model.

This supplement must be used in conjunction with the *1998 Sea-Doo Operator's Guide* (P/N 219 000 076), which contains all the general information. When a specific model is discussed, refer to the information regarding the GTX Limited, except for the following subjects covered in this supplement.

◆ SAFETY WARNING

Disregarding any of the safety precautions and instructions contained in this *Operator's Guide Supplement*, the *Operator's Guide*, the *Safety Handbook* and on *Product Warning Labels* could cause injury, including the possibility of death.

This *Operator's Guide Supplement*, the *Operator's Guide*, the *Safety Handbook* and *Videocassette* should remain with the watercraft at the time of resale.

TABLE OF CONTENTS

LOCATION OF THE IMPORTANT LABELS.....	1
WATERCRAFT IDENTIFICATION	3
COMPONENT FUNCTIONS	3
FUEL AND LUBRICATION	5
OPERATING INSTRUCTIONS	5
POST-OPERATION CARE.....	6
SPECIAL PROCEDURES.....	7
MAINTENANCE	9
STORAGE	11
10-HOUR INSPECTION CHECK LIST	14
PERIODIC INSPECTION CHART	15
PRE-SEASON PREPARATION CHART.....	16
TROUBLESHOOTING.....	17
SPECIFICATIONS	20

LOCATION OF THE IMPORTANT LABELS

Please read the following labels carefully before operating this watercraft.

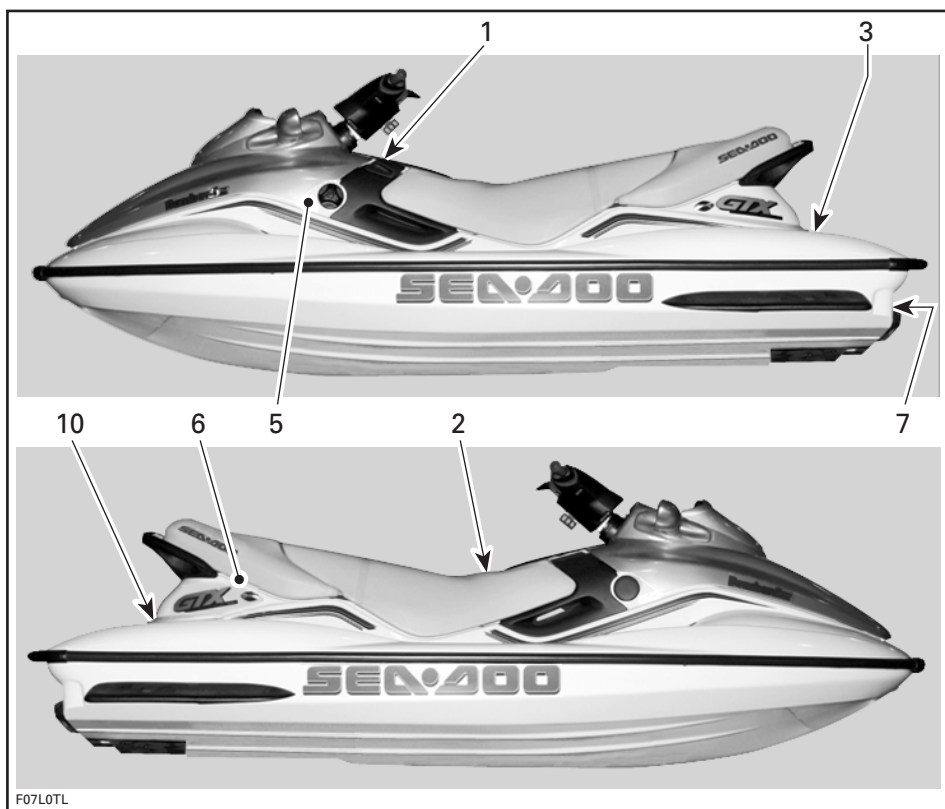

1

◆ WARNING

**Read all warning label, Operator Guide & safety documents before operating.
Severe injury or death can result from ignoring such information or improper use of the watercraft.**

- Check throttle & steering operation before starting engine.
- Directional control is lost when throttle is released or engine shut off.
- Do not splash others or jump waves or wakes with this watercraft.
- Properly attach safety tether to your PFD.
- Keep a safe distance from other water users. Observe boating regulations.
- This watercraft is not design for night-time operation.

F00A0RL

2

• CAUTION

USE BOMBARDIER-ROTAX INJECTION OIL OR HIGHER QUALITY LOW ASH API TC INJECTION OIL FOR 2 CYCLES ENGINES.

NEVER USE NMMA TC-W, TC-WII or TC-W3 outboard motor oils.

F00L06Z

7

▼ CAUTION

TO AVOID POSSIBLE ENGINE FLOODING WHEN ROLLED OVER:



- MAKE SURE ENGINE IS OFF
- GRAB INLET GRATE AND STEP ON BUMPER RAIL
- ROLL BOAT COUNTERCLOCKWISE

F06L0DY

3

"THIS BOAT IS NOT REQUIRED TO COMPLY WITH THE FOLLOWING U.S. COAST GUARD SAFETY STANDARDS IN EFFECT ON THE DATE OF CERTIFICATION:

- Fuel System
- Display of Capacity Information
- Safe Loading
- Flotation
- Powered Ventilation

AS AUTHORIZED BY U.S. COAST GUARD GRANT OF EXEMPTION (CGB 88-001)."

Bombardier Corp. 7575 Bombardier Court, Wauau, WI 54401

Made in Canada/Fabriqué au Canada Bombardier Inc. Rd./Entr.1988

F02L2DZ

10

◆ WARNING

ENGINE MUST BE OFF WHEN USING BOARDING STEP. KEEP AWAY FROM JET OR INTAKE GRATE. STAY ON CENTER OF THE STEP. ONLY ONE PERSON AT THE TIME ON THE STEP. NEVER USE THE STEP FOR PULLING, TOWING, DIVING OR JUMPING, BOARDING A PWC THAT IS OUT OF WATER OR ANY OTHER PURPOSE FOR WHICH IT WAS NOT DESIGNED.

F07L11Y

5

◆ WARNING

WHILE FUELING, STOP ENGINE. FUEL TANK MAY BE PRESSURIZED, SLOWLY TURN CAP WHEN OPENING. KEEP WATERCRAFT LEVEL. DO NOT OVERFILL. CHECK OIL LEVEL. PERIODICALLY, VERIFY FUEL SYSTEM.

F01L6VY

6

• WARNING

DO NOT BOOST BATTERY WHILE INSTALLED.

F00L05Y

WATERCRAFT IDENTIFICATION

Engine Identification Number

The Engine Identification Number (E.I.N.) is located on the upper crankcase on PTO side.

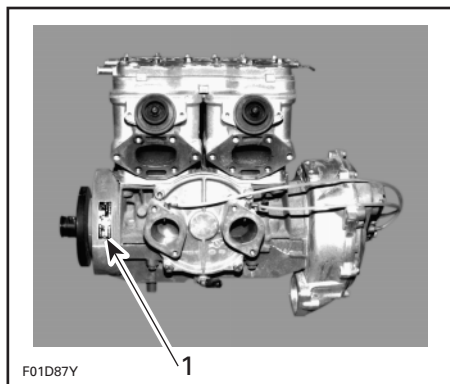

1. Engine Identification Number

COMPONENT FUNCTIONS

Added Features

The following features have been added for this specific model.

Storage Compartment Cover Safety Lock

A convenient lock is provided to protect personal articles when the watercraft is unattended.

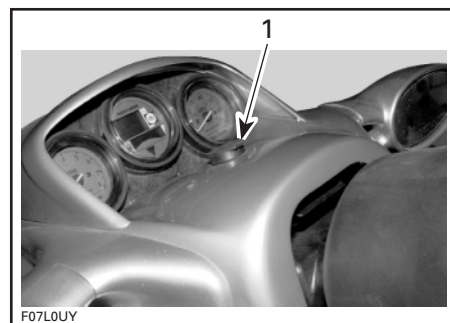

1. Safety lock

To lock the storage compartment cover, insert key and rotate it 1/2 turn.

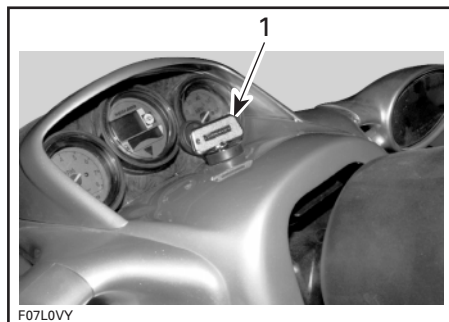

1. Insert key and rotate it 1/2 turn to lock cover

To unlock the storage compartment cover, turn key in the opposite direction.

Adjustable Handlebar

The handlebar height can be adjusted to suit rider preferences.

To perform this adjustment, turn the knob underneath the handlebar.



1. Adjustment knob

Cargo Cleats

These cleats are provided for securing baggage.

CAUTION

Do not use the cleats as a tie-down point for transportation or mooring.

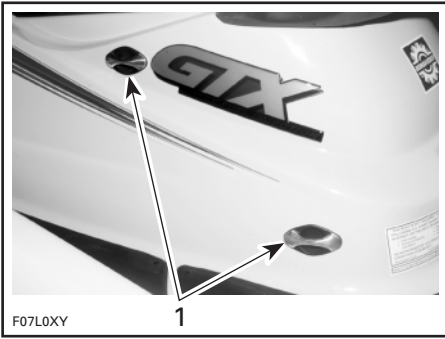

1. Cargo cleats (each side)

Stern Eyelet

This eyelet allows a rope with a hook, a closed end or an open end to be attached.

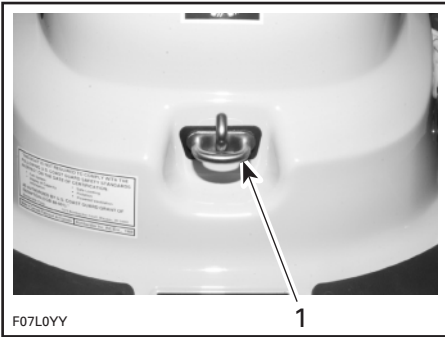

1. Stern eyelet

Boarding Step

A convenient step to help reboarding the watercraft.

◆ WARNING

Engine must be OFF when using boarding step. Keep away from jet or intake grate. Stay on center of the step. Only one person at the time on the step. Never use the step for pulling, towing, diving or jumping, boarding a PWC that is out of water or any other purpose for which it was not designed.

Bow Bag

A convenient watertight bow bag is supplied with this watercraft. The bow bag is tailor-made for the front storage compartment.

Modified or Deleted Features

The following features have been either modified or deleted for this specific model.

Throttle Lever

When the engine is stopped, no fuel is injected when depressing the throttle lever. The carburetors are replaced by a throttle body. Any reference to the carburetors in the *Operator's Guide* should be disregarded.

Choke Lever

There is no choke lever. The enrichment of the air/fuel mixture is controlled by the electronic control unit (ECU). Any reference to the choke cable in the *Operator's Guide* should be disregarded.

Fuel Valve

With the Rotax Fuel Injection, there is no need for a fuel valve.

There is no reserve. When the fuel is low in the tank (1/8), the Info Center displays a "LOW FUEL" warning message and the LED will blink. Every 55 seconds, the monitoring beeper will also sound 5 seconds to warn the operator.

◆ WARNING

Always refill the fuel tank at the first opportunity.

Any reference to the fuel valve in the *Operator's Guide* should be disregarded.

FUEL AND LUBRICATION

Recommended Fuel

Use unleaded gasoline with a minimum of 87 octane (RON + MON/2) specification.

NOTE: Look on service station pump sticker for octane specification. Do not mix oil with fuel except at engine break-in. Always check injection oil tank level when refueling.

The use of good quality fuel is necessary. A well known fuel brand is highly recommended.

▼ CAUTION

Never experiment with other fuels or fuel ratios. Never use fuel containing more than 10% alcohol (ethanol or methanol). The use of non-recommended fuel can result in watercraft performance deterioration and damage to critical parts in the fuel system and engine components.

Recommended Oil

Use BOMBARDIER ROTAX INJECTION OIL which is available from authorized dealers. It is a blend of specially selected base oils and additives which provides proper lubrication, engine cleanliness and minimum spark plug fouling.

NOTE: High quality low ash API TC injection oil for 2-cycle engines can be used if BOMBARDIER ROTAX INJECTION OIL is not available.

▼ CAUTION

Never use 4-cycle petroleum or synthetic motor oil and never mix these with outboard motor oil. Do not use NMMA TC-W, TC-W2 or TC-W3 outboard motor oils or other ashless type 2-cycle oil. Avoid mixing different brands of API TC oil as resulting chemical reaction may cause severe engine damage.

OPERATING INSTRUCTIONS

Starting the Engine

Before unloading the watercraft from the trailer, it can be started for about 10 seconds to verify proper operation.

◆ WARNING

Do not touch electrical parts or jet pump area when engine is running.

Attach the safety lanyard to the operator's PFD and snap the cap to the switch before starting the engine.

◆ WARNING

Only start the watercraft once all controls have been checked and operate properly. Operator and passenger (if applicable) should be sitting on the watercraft seat prior to starting the engine.

Cold and Warm Engine

Firmly grip handlebar with both hands and place both feet on the floorboard.

To start engine, depress and hold the button. Release immediately after engine is started.

NOTE: Do not depress the throttle lever to start either a cold or warm engine.

Slowly accelerate to reach deeper water. Do not apply full throttle until the engine is at normal operating temperature.

◆ WARNING

In shallow water, shells, sand, pebbles or other objects could be drawn up by the jet pump and damage impeller, components or clog the cooling system. Also, debris could be thrown rearward into bystanders.

POST-OPERATION CARE

Cooling System Flushing and Engine Internal Lubrication

Flushing the cooling system with fresh water is essential to neutralize corroding effects of salt or other chemical products present in water. It will help to clean up sand, salt, shells or other particles in water jackets (engine, exhaust manifold, tuned pipe) and/or hoses.

Engine lubrication and flushing should be performed when the watercraft is not expected to be used further the same day or when the watercraft is stored for any extended time.

Proceed as follows:

◆ WARNING

Perform this operation in a well ventilated area.

Clean jet pump by spraying water in its inlet and outlet and then BOMBARDIER LUBE lubricant.

To flush engine, connect a garden hose to the water outlet located at the rear of watercraft near the jet pump.

NOTE: A quick connect adapter is supplied with the watercraft and can be used to ease hose installation.

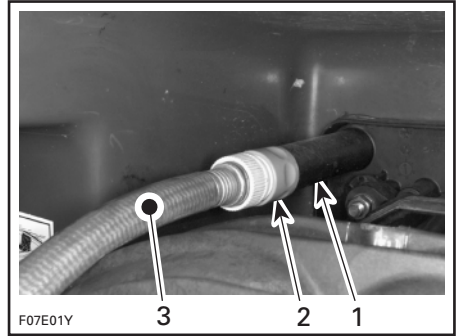

TYPICAL

1. Water outlet
2. Quick connect adapter (supplied)
3. Garden hose

Start the engine **then** immediately open the water tap.

◆ WARNING

Do not touch any electrical parts or jet pump area when engine is running.

▼ CAUTION

Never flush a hot engine. Always start the engine before opening the water tap. Open water tap immediately after engine is started to prevent overheating.

Run the engine about 3 minutes at a fast idle around 3500 RPM.

Spray BOMBARDIER LUBE lubricant into air intake silencer keeping engine at fast idle.

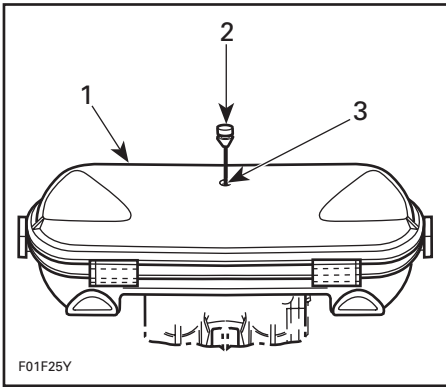

- 1. Air intake silencer
- 2. Pull plug
- 3. Spray BOMBARDIER LUBE here

NOTE: Lubrication of engine should be done for at least 1 minute. Close the water tap then stop the engine.

▼ CAUTION

Always close the water tap before stopping the engine.

- Disconnect the garden hose.
- Wipe up any residual water from the engine.
- Remove spark plug cables and connect them on the grounding device.

◆ WARNING

Always use spark plug cable grounding device when removing spark plugs.

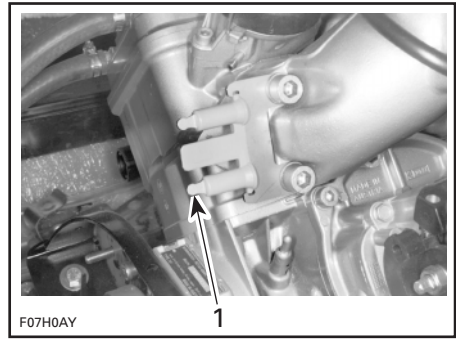

1. Grounding device

Remove both spark plugs and spray BOMBARDIER LUBE lubricant into each cylinder.

NOTE: For the storage period, use Bombardier storage oil (P/N 413 711 600).

Fully apply the throttle lever then depress the start/stop button to crank the engine a few turns to distribute the oil onto cylinder wall.

NOTE: No fuel is injected in the engine when the throttle lever is fully applied then the starter activated.

Apply anti-seize lubricant on spark plug threads then reinstall them.

Reinstall plug on air intake silencer cover.

NOTE: Engine fogging should be done whenever the watercraft is to be stored for a few days or a long period.

SPECIAL PROCEDURES

Submerged Watercraft

If the watercraft is submerged and engine is water-flooded, it is strongly recommended that the watercraft be serviced by an authorized dealer immediately.

In the event the engine cannot be serviced within a few hours, remove spark plug cables and connect them on the grounding device.



WARNING

Never crank engine with spark plugs removed unless spark plug cables are connected to the grounding device.

Remove spark plugs and dry them with a clean and dry cloth.

Cover spark plug holes with a rag.

Fully apply the throttle lever then depress the start/stop button to crank engine for approximately 10 seconds. This will allow water to escape from spark plug openings.

Spray BOMBARDIER LUBE lubricant into spark plug holes.

Crank engine again with the throttle fully applied.

Reinstall spark plugs.

Towing the Watercraft in Water

Special precautions should be taken when towing a Sea-Doo watercraft in water.

Maximum recommended towing speed is 24 km/h (15 MPH).

When towing your watercraft in water, pinch the water supply hose from the impeller housing to the engine with a large hose pincher (P/N 529 030 400) shown in the following illustration.

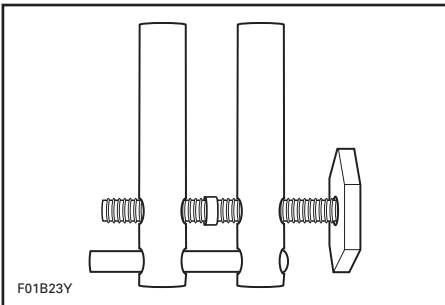

This will prevent the cooling system from filling which may lead to water being injected into and filling the exhaust system. Without the engine running there isn't any exhaust pressure to carry the water out of the exhaust outlet.



CAUTION

Failure to do this may result in damage to the engine. If you must tow a stranded watercraft in water and do not have a hose pincher be sure to stay well below the maximum towing speed of 24 km/h (15 MPH).

Snugly install the hose pincher on the hose as shown.

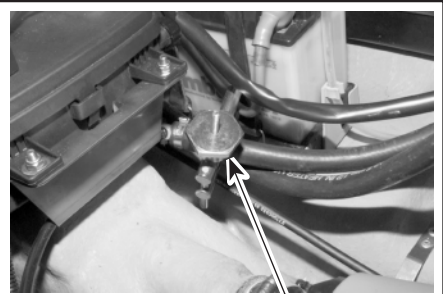

1. Hose pincher



CAUTION

When finished towing the watercraft, hose pincher must be removed before operating it.

Flooded Engine

If the engine does not start and it is suspected to be flooded, proceed as follows:

Remove spark plug cables and connect them on the grounding device.

◆ WARNING

Always use spark plug cable grounding device when removing spark plugs.

Remove spark plugs and dry them using a rag.

Cover spark plug holes with a rag.

Install the safety lanyard cap on the switch.

Depress and hold the throttle lever at full throttle position.

Depress the start/stop button to crank the engine approximately 10 seconds.

Proceeding in this order, no fuel is injected and the accumulated fuel in the engine will be expelled.

Reinstall spark plugs and connect cables.

Start engine normally without applying the throttle.

MAINTENANCE

Lubrication

Use SEA-DOO synthetic grease and lubricate the PTO flywheel every 10 hours. Proceed as follows:

Remove seats to expose engine compartment.

Remove the wing nuts, washers and pull out PTO flywheel guard.

◆ WARNING

Always remove safety lanyard cap from its receptacle to prevent accidental engine starting before removing the PTO flywheel guard.

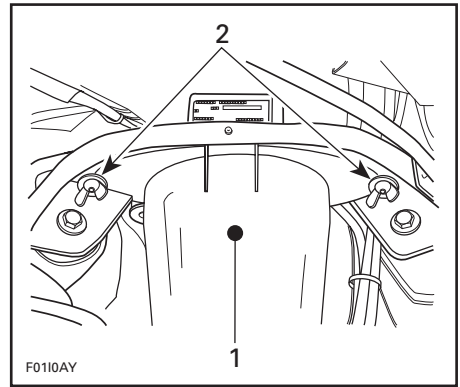

1. Flywheel guard
2. Wing nuts

Using a grease gun, carefully lubricate PTO flywheel at grease fitting until boot is just beginning to expand.

▼ CAUTION

Immediately stop lubricating as soon as boot begins to expand.

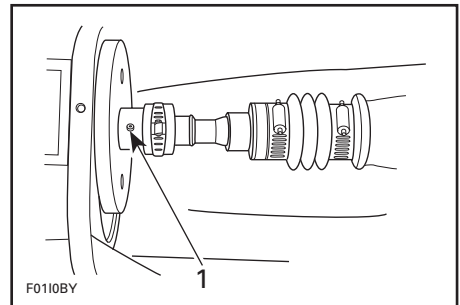

1. Grease PTO flywheel

Secure PTO flywheel guard.

Fuses

The electrical system is protected with 5 fuses.

Three fuses are located on the Multi-Purpose Electronic Module (MPEM) and the other two fuses are in the rear electrical box.

Two fuses protect the charging system. If the battery is regularly discharged, check the 15 A fuse on the MPEM and the 20 A fuse in the rear electrical box.

A 5 A fuse protects the power supply of the MPEM. If the starter does not operate, check the 5 A fuse.

The second 20 A fuse in the rear electrical box protects the power supply of the Electronic Control Unit (ECU).

The 7.5 A fuse on the MPEM protects the fuel pump. If the engine does not start, check this fuse.

To access fuses on the Multi-Purpose Electronic Module, open storage compartment cover and remove basket.

Locate MPEM on the left side of watercraft.

Unclip the fuse cover from the MPEM.

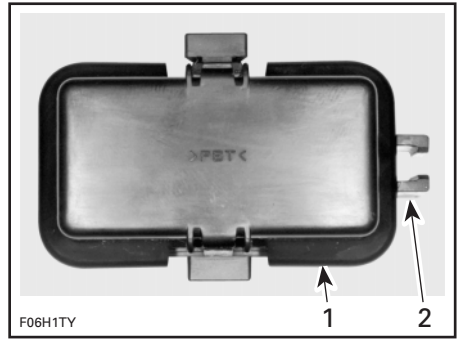

1. Fuse cover
2. Fuse tabs

NOTE: There is 2 spare fuses on the MPEM.

To access the 20 A fuses in the rear electrical box, remove seats.

Remove basket.

Unclip and remove cover of the rear electrical box.

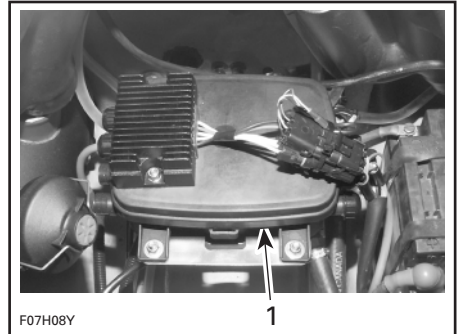

1. Rear electrical box

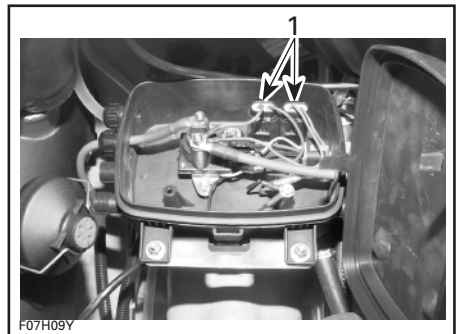

REAR ELECTRICAL BOX OPENED

1. Fuse holders

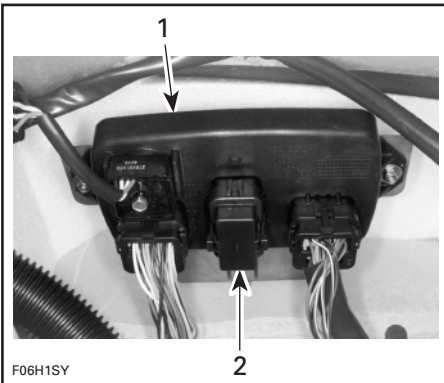

TYPICAL

1. MPEM
2. Fuse cover

Use the tabs of the fuse cover to remove and reinstall fuses.

Unclip and pull out fuse holders to check fuse condition.

If a fuse is defective, replace it by one of the same rating.

▼ CAUTION

Do not use a higher rated fuse as this can cause severe damage. Refer to SPECIFICATIONS section for recommended fuse rating. If a fuse is regularly burnt, refer to an authorized dealer.

◆ WARNING

If any water is found in the rear electrical box, immediately refer to an authorized dealer before operating the watercraft.

NOTE: Ensure to properly close cover of the rear electrical box, making sure seal is well positioned.

STORAGE

It is recommended that the watercraft be serviced by an authorized dealer for storage but the following operations can be performed by you with a minimum of tools.

▼ CAUTION

Do not run the engine during the storage period.

Engine Draining

Disconnect the water supply hose used to cool the magneto. It features a quick connect fitting. Press both tabs and pull fitting in order to disconnect hose.

This hose is located at the bottom of the magneto cover beside the engine support.

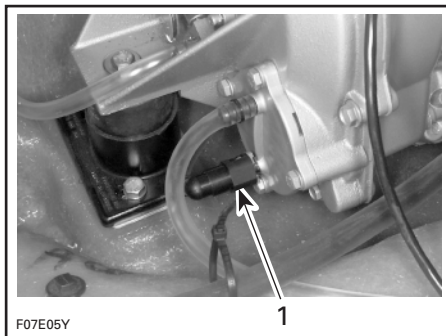

1. Disconnect this hose

Water should flow out of the fitting (magneto cooling circuit) and hose (crankcase heat exchanger).

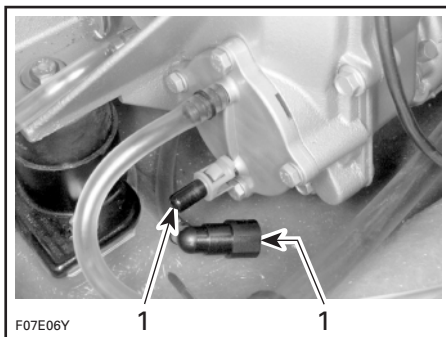

1. Make sure water flows out of fitting and hose

▼ CAUTION

Water in engine must be free to flow out. Should water freeze in engine, severe damage will occur.

Fuel System

SEA-DOO fuel stabilizer (or equivalent), can be added in fuel tank to prevent fuel deterioration. Follow manufacturer's instructions for proper use.

NOTE: Fuel stabilizer should be added prior engine lubrication.

Cooling System Flushing and Engine Internal Lubrication

Refer to procedure in POST-OPERATION CARE.

Propulsion System

Lubricant in jet pump reservoir should be drained and reservoir cleaned. Re-fill with SEA-DOO synthetic polyolester oil (75W90 GL5 type C gear lube). Refer to an authorized dealer for this operation.

▼ CAUTION

Use only SEA-DOO jet pump oil or equivalent synthetic gear oil, otherwise component service life could be reduced. Do not mix oil brands or types.

Grease PTO flywheel as explained in the MAINTENANCE section.

Battery

Contact your authorized dealer or refer to the appropriate *Shop Manual* for proper storage procedure.

Watercraft Cleaning

Clean the bilge with hot water and detergent or with bilge cleaner. Rinse thoroughly. Lift front end of watercraft to completely drain bilge. If any repairs are needed to body or to the hull contact your dealer. For paint touch up to mechanical parts use Bombardier spray paint. For small gelcoat repairs, a Bombardier repair kit is available. Replace damaged labels/decals.

NOTE: Bilge cleaning should be done prior to anticorrosion treatment.

Wash the body with soap and water solution (only use mild detergent). Rinse thoroughly with fresh water. Remove marine organisms from the hull. Apply a good quality marine wax.

▼ CAUTION

Never clean apparent fiberglass and plastic parts with strong detergent, degreasing agent, paint thinner, acetone, etc.

If the watercraft is to be stored outside, cover it with an opaque tarpaulin to prevent sun rays and grime from affecting the plastic components, watercraft finish as well as preventing dust accumulation.

▼ CAUTION

The watercraft must never be left in water for storage. Never leave the watercraft stored in direct sunlight.

Anticorrosion Treatment

Wipe off any residual water in the engine compartment.

Spray BOMBARDIER LUBE lubricant over metallic components in engine compartment.

Lubricate the throttle cable with BOMBARDIER LUBE lubricant.

The front seat should be partially left opened during storage. This will avoid engine compartment condensation and possible corrosion.

Additional Recommended Protection

In cool regions (where freezing point may be encountered), cooling system should be filled with an equal part of water and antifreeze solution.

▼ CAUTION

During winter storage in cold climates (where freezing may occur), always add antifreeze and water solution to cooling system. Mix in equal parts.

▼ CAUTION

Always use ethylene glycol anti-freeze containing corrosion inhibitors specifically recommended for aluminum engines.

Install a hose pincher to water return hose of the magneto cooling circuit.

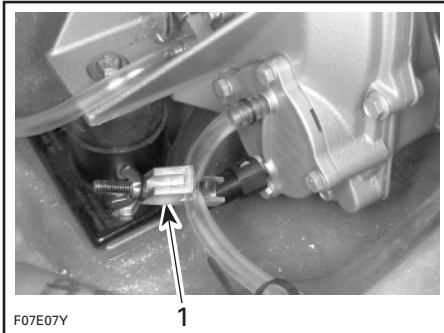

1. Hose pincher to water return hose

Disconnect the engine water return hose.

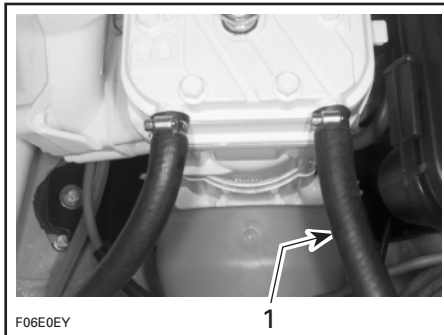

TYPICAL
1. Disconnect the engine water return hose

Install a hose pincher to engine water supply hose.

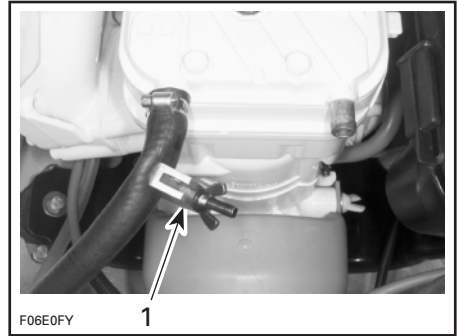

TYPICAL
1. Hose pincher installed on the engine water supply hose

Temporarily install a short piece of hose to engine water return at cylinder head.

Insert a funnel into hose and pour antifreeze mixed with water in engine until the colored solution appears in the water return hose of the magneto cooling circuit.

Remove temporary hose and reconnect engine water return hose.

Remove hose pinchers.

Most of the antifreeze will drain out from fitting near the exhaust outlet when removing the hose pinchers. Use a container to recover it. **DISPOSE OF ANTIFREEZE AS PER YOUR LOCAL LAWS AND REGULATIONS.**

NOTE: Although antifreeze will mainly drain out, the antifreeze has mixed with the water that was possibly trapped in the cylinder water jackets, crankcase heat exchanger and the magneto cooling circuit, preventing freezing problems.

At pre-season preparation, drain the remaining antifreeze from cooling system prior using the watercraft.

10-HOUR INSPECTION CHECK LIST

DESCRIPTION	✓
Engine ignition timing if required	
Spark plug inspection, cleaning and adjustment	
Fuel system lines and fasteners/ pressurization test	
Throttle cable adjustment if required	
Oil lines and filter	
Oil injection pump adjustment if required	
Engine support and engine rubber mounts	
Muffler, battery and reservoir fastening devices	
Exhaust system hose clamps	
Throttle body and flame arrester base	
Steering system inspection	
Steering cable adjustment if required	
Reverse cable adjustment if required	
Cooling system hose condition and fasteners	
Bailer pick-ups, check for obstructions	
Fuel injection sensors verification	
Digitally Encoded Security System	
Monitoring beeper	
Ground connections (starter, battery, etc.)	
Jet pump oil replacement	
PTO flywheel lubrication	
Seal carrier verification	
Inspection of fasteners for tightness	
Hull inspection	

We recommend that this inspection chart be signed by an authorized dealer.

Date of 10-hour inspection

Authorized dealer signature

Dealer code

The 10-hour inspection is at the expense of the watercraft owner.

PERIODIC INSPECTION CHART

DESCRIPTION	FREQUENCY				To be performed by
	every 10 hours	every 25 hours	every 50 hours	every 100 hours or seasonally	
Lubrication/corrosion protection	①		✓		OPERATOR
Engine ignition timing				✓	DEALER
Spark plug replacement			✓		DEALER
Fuel injector cleaning		✓			DEALER
Fuel injection sensors verification				✓	DEALER
Throttle cable, inspection/lubrication	①	✓			OPERATOR
Throttle cable adjustment				✓	DEALER
Oil injection pump adjustment				✓	DEALER
Oil filter inspection		✓			DEALER
Oil filter replacement				✓	DEALER
Fuel tank straps	✓				OPERATOR
Oil tank straps	✓				OPERATOR
Engine head bolts, retorque				✓	DEALER
Engine counterbalance shaft oil level				✓	DEALER
Steering system			✓		DEALER
Reverse system/reverse cable adjustment				✓	DEALER
Fastener tightening (flame arrester, throttle body, engine mount, exhaust system, etc.)			✓		DEALER
Muffler, battery and reservoir fastening devices			✓		OPERATOR
Fuel lines, check-valve and fuel system pressurization	✓	✓	✓	✓	DEALER
Fuel vent line pressure relief valve inspection		✓			DEALER
Battery condition			✓		DEALER
Ground connections (battery, starter, etc.)		✓			DEALER
Monitoring beeper			✓		DEALER
Jet pump reservoir oil level/oil condition		✓		Replace	DEALER
Jet pump cover pusher inspection				✓	DEALER
Impeller condition and impeller/wear ring clearance			✓ ②		DEALER
Drive shaft boot and spline condition			✓ ②		DEALER
PTO flywheel lubrication	✓				OPERATOR
Seal carrier inspection			✓		DEALER
Water intake grate condition			✓ ②		OPERATOR
Hull condition				✓	OPERATOR
Cooling system flushing		✓ ③			OPERATOR

① Every 10 hours in salt water use.

② These items have to be initially checked after 25 hours. Thereafter, servicing to be made as specified in this chart.

③ Daily flushing in salt water or foul water use.

PRE-SEASON PREPARATION CHART

NOTE: It is highly recommended that the dealer perform the annual safety inspection and factory campaigns in addition to the pre-season preparation all at the same time.

OPERATIONS	To be performed by
Lubrication/corrosion protection	OPERATOR
Battery condition/charging and reinstallation	DEALER
Battery, starter connections and routing ②	DEALER
Spark plug replacement ①	OPERATOR
Jet pump oil inspection	DEALER
Propulsion system inspection	DEALER
Oil filter replacement	DEALER
Fuel tank straps	OPERATOR
Oil tank straps	OPERATOR
Oil injection tank filling	OPERATOR
Flame arrester inspection ②	DEALER
Fuel line condition ②	DEALER
Filler neck, fuel tank and fuel cap condition ②	DEALER
Check valves, fasteners, fuel system pressurization ②	DEALER
Throttle ② cable inspection/adjustment	DEALER
Oil injection pump adjustment and bleeding	DEALER
Engine ignition timing	DEALER
Fuel injection sensors verification	DEALER
Steering system adjustment/inspection ②	DEALER
Reverse cable adjustment	DEALER
Inspection of bailer pick-ups	DEALER
Inspection of cooling system hoses	DEALER
Monitoring beeper	DEALER
Digitally encoded security system	DEALER

① Before installing new spark plugs, it is suggested to burn the excess BOMBARDIER LUBE lubricant by starting the engine using the old spark plugs.

② Safety item covered in the annual safety inspection.

TROUBLESHOOTING

The following chart is provided to help in diagnosing the probable source of simple troubles. You may be able to solve many of these problems rather quickly, but others may require the skills of a mechanical technician. In such cases, consult an authorized dealer for servicing.

Monitoring Beeper Coded Signals

CODED SIGNALS	POSSIBLE CAUSE	REMEDY
2 short beeps (while installing safety lanyard on switch).	<ul style="list-style-type: none"> • Confirms safety lanyard signal operation. 	Engine can be started.
1 long beep (while installing safety lanyard on craft switch or when pressing start/stop button).	<ul style="list-style-type: none"> • Safety lanyard on switch for more than 10 minutes without starting engine. • Bad connection. • Wrong safety lanyard. • Defective safety lanyard. • Salt water in safety lanyard cap. • Improper operation of MPEM or defective wiring harness. 	<p>Remove and reinstall safety lanyard on switch.</p> <p>Reinstall safety lanyard cap correctly over switch.</p> <p>Use a safety lanyard that has been programmed for the craft.</p> <p>Use another programmed safety lanyard.</p> <p>Clean safety lanyard cap to remove salt water.</p> <p>Refer to an authorized dealer.</p>
4 short beeps	<ul style="list-style-type: none"> • Discharged battery. • No communication between ECU and MPEM. 	<p>Refer to an authorized dealer.</p> <p>Refer to an authorized dealer.</p>
A 2 seconds beep every 60 seconds intervals.	<ul style="list-style-type: none"> • Fuel tank level is low. 	Refill.
8 short beeps.	<ul style="list-style-type: none"> • Defective MPEM. 	Refer to an authorized dealer.
Continuously beeps.	<ul style="list-style-type: none"> • Engine overheats. 	See ENGINE OVERHEATING.

Engine will not Start

OTHER OBSERVATION	POSSIBLE CAUSE	REMEDY
Engine does not turn over.	<ul style="list-style-type: none"> • Safety lanyard removed. • Burnt fuse. • Discharged battery. • Battery connections, corroded or loose. • Water flooded engine. 	<p>Install cap over switch.</p> <p>Check wiring then replace fuse.</p> <p>Refer to an authorized dealer.</p> <p>Refer to an authorized dealer.</p> <p>Refer to Submerged Watercraft in SPECIAL PROCEDURES.</p>
Engine turns slowly.	<ul style="list-style-type: none"> • Discharged or weak battery. 	Refer to an authorized dealer.
Engine turns normally.	<ul style="list-style-type: none"> • Fuel flooded engine. • Fuel tank empty or water-contaminated. • Burnt fuel pump fuse • Fouled/defective spark plugs. • Electrical problem. 	<p>Refer to Flooded Engine in SPECIAL PROCEDURES.</p> <p>Refill. Siphon and fill with fresh fuel.</p> <p>Check wiring then replace fuse.</p> <p>Replace.</p> <p>Refer to an authorized dealer.</p>

Engine Misfires, Runs Irregularly

OTHER OBSERVATION	POSSIBLE CAUSE	REMEDY
Weak spark.	<ul style="list-style-type: none"> Fouled/defective/worn spark plugs. Faulty rev limiter. 	Replace. Refer to an authorized dealer.
Lean fuel mixture.	<ul style="list-style-type: none"> Fuel: Level too low, stale or water-contaminated. Clogged fuel injectors. Defective sensor or ECU. 	Siphon and/or refill. Refer to an authorized dealer. Refer to an authorized dealer.
Rich fuel mixture (high fuel consumption).	<ul style="list-style-type: none"> Flame arrester dirty/clogged. Defective sensor or ECU. 	Clean or replace. Refer to an authorized dealer.

Engine Overheats

OTHER OBSERVATION	POSSIBLE CAUSE	REMEDY
Monitoring beeper sounds continuously.	<ul style="list-style-type: none"> Clogged jet pump water intake. Clogged coolant system. 	Clean. Flush cooling system.

Engine Continually Backfires

OTHER OBSERVATION	POSSIBLE CAUSE	REMEDY
Weak spark.	<ul style="list-style-type: none"> Fouled/defective/worn spark plugs. 	Replace.
Overheated engine.	<ul style="list-style-type: none"> See ENGINE OVERHEATS. 	Refer to an authorized dealer.

Engine Pinging or Knocking

OTHER OBSERVATION	POSSIBLE CAUSE	REMEDY
	<ul style="list-style-type: none"> Poor quality gasoline/low octane. 	Use well known quality and recommended gasoline.
	<ul style="list-style-type: none"> Spark plug heat range too high. 	Use recommended spark plugs.
	<ul style="list-style-type: none"> Ignition timing. 	Refer to an authorized dealer.

Engine Lacks Acceleration or Power

OTHER OBSERVATION	POSSIBLE CAUSE	REMEDY
	<ul style="list-style-type: none"> Clogged fuel injectors. 	Refer to an authorized dealer.
	<ul style="list-style-type: none"> Low fuel pressure. 	Refer to an authorized dealer.
	<ul style="list-style-type: none"> Stick RAVE valves. 	Refer to an authorized dealer.
Overheated engine.	<ul style="list-style-type: none"> See ENGINE OVERHEATS. 	

Watercraft Can Not Reach Top Speed

OTHER OBSERVATION	POSSIBLE CAUSE	REMEDY
Cavitation.	<ul style="list-style-type: none">• Jet pump water intake clogged.• Damaged impeller.	Clean. Replace. Refer to an authorized dealer.

Abnormal Noise from Propulsion System

OTHER OBSERVATION	POSSIBLE CAUSE	REMEDY
Cavitation.	<ul style="list-style-type: none">• Weeds or debris jammed around impeller.• Damaged impeller shaft or drive shaft.	Clean and check for damage. Refer to an authorized dealer.

SPECIFICATIONS

ENGINE		GTX RFI (5666/5843)
Engine type		Bombardier-Rotax 787, 2-stroke
Induction type		Rotary valve
Exhaust system		Water cooled/water injected with regulator
Exhaust valve		Rotax Adjustable Variable Exhaust (R.A.V.E.)
Lubrication	Type	Oil injection
	Oil type	BOMBARDIER-ROTAX injection oil
Number of cylinders		2
Displacement		781.6 cm ³ (47.7 in ³)
Rev limiter setting		7100 (± 50) RPM
COOLING SYSTEM		
Type		Water cooled, total loss type. Direct flow from propulsion unit.
ELECTRICAL SYSTEM		
Magneto generator output		270 W @ 6000 RPM
Ignition system type		Digital inductive type
Spark plug	Make and type	NGK, BR8ES
	Gap	1.0 mm (.039 in)
Starting system		Electric starter
Battery		12 V, 19 A
Fuse	Starting system	5 A
	Charging system	15 A (1) 20 A (1)
	Fuel pump	7.5 A
	MPEM	5 A
FUEL SYSTEM		
Fuel type		Regular unleaded gasoline
Fuel injection		Rotax Fuel Injection, single throttle body

PROPULSION		GTX RFI (5666/5843)
Propulsion system		Bombardier Formula pump
Jet pump type		Axial flow, single stage
Transmission		Direct drive
Impeller shaft reservoir oil type		SEA-DOO jet pump synthetic polyolester oil 75W90 GL5
Pivoting angle of direction (nozzle)		~ 23°
Minimum required water level for jet pump		90 cm (3 ft)
DIMENSIONS		
Number of passengers ①		3
Overall length		312 cm (122.8 in)
Overall width		119 cm (47 in)
Overall height		94 cm (37 in)
Weight		288 kg (635 lb)
Load limit (passengers + luggage)		242 kg (534 lb)
CAPACITIES		
Fuel tank		56.5 L (15 U.S. gal)
Impeller shaft reservoir	Capacity	125 mL (4.2 U.S. oz)
	Oil level	Up to plug
Oil injection reservoir		6 L (1.6 U.S. gal)

① Refer to load limit.

N.A.: Not Applicable.

BOMBARDIER INC. reserves the right to make changes in design and specifications and/or to make additions to, or improvements in its products without imposing any obligation upon itself to install them on its products previously manufactured.



•*TRADEMARKS OF BOMBARDIER INC.
• 1998 BOMBARDIER INC. ALL RIGHTS RESERVED
LITHO'D IN CANADA