

OPERATOR'S GUIDE

MODELS

5806
5808
5807

VERSION FRANÇAISE AU REVERS

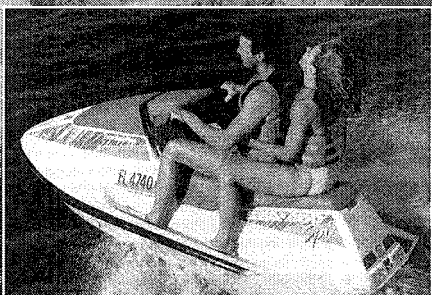
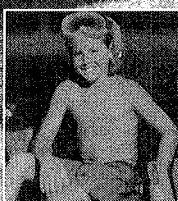

SEA-DOO

SP, SPI, & SPX



P219000006 CA2001



219-000-006

SAFETY WARNING

Disregarding of the safety precautions and instructions contained in this *Operator's Guide* and the *Safety Handbook* could cause injury, including the possibility of death.

This *Operator's Guide* and the *Safety Handbook* should remain with the watercraft at the time of resale.

AFTER SALES SERVICE
BOMBARDIER INC.
VALCOURT (QUEBEC)
CANADA J0E 2L0



**The following trademarks are property of
Bombardier Inc. :**

SEA-DOO®
Sea-Doo Lube®
Sea-Doo Jet Pump Synthetic Oil
Sea-Doo Synthetic Grease

Gelcote® is a trademark of Gelcote International
Sta-Bil® is a trademark of Gold Eagle Co.

Doin'it on your new Sea-Doo

Nowadays it seems that everywhere you look, everybody's Doin'it. Folks are Doin'it with their friends, and friends are Doin'it with their folks. And right now everyone at Sea-Doo would like to say, "Welcome aboard, we're glad you're Doin'it too."

As a new member of the Sea-Doo team, please read this operator's guide and follow the instructions for safe, responsible and courteous riding. This will help protect the value of your investment as well as the safety of you and your passengers. Remember, you're now the skipper of a Class A motorboat. And as such, you're responsible for the safety of anyone riding your boat, as well as any damage that may occur from your wake.

When introducing your family and friends to the sport, be sure they understand the importance of courteous, responsible riding as well. After all, you are the future of the sport. By operating your Sea-Doo watercraft with regard for the rights of other boaters, skiers, fishermen and swimmers, you make it possible for others to continue to enjoy the sport.

Finally, be sure to visit your Sea-Doo dealer regularly for maintenance, parts and accessories. So you can keep your Sea-Doo running at peak performance, and keep on Doin'it for seasons to come. Bon voyage!

TABLE OF CONTENTS

| | |
|--------------------------------------------------|-----------|
| FOREWORD | 4 |
| SAFETY | 5 |
| SEA-DOO WATERCRAFT LIMITED WARRANTY | 8 |
| DISTRIBUTORS' LIST | 10 |
| WARRANTY QUESTIONS AND ANSWERS | 11 |
| REGISTRATION NUMBER LOCATION | 13 |
| IDENTIFICATION OF COMPONENTS | 14 |
| Identification Numbers | 14 |
| Controls and Components Location | 15 |
| FUEL / OIL AND BREAK-IN | 24 |
| Recommended Fuel | 24 |
| Recommended Oil | 24 |
| Oil Injection System | 24 |
| Engine Break-In | 25 |
| 10-Hour Inspection | 25 |
| DAILY PRE-OPERATION CHECKS | 27 |
| Hull | 27 |
| Jet Pump Water Intake | 27 |
| Bilge | 28 |
| Battery | 28 |
| Fasteners | 28 |
| Fuel / Oil Reservoirs and Filters | 28 |
| Engine Compartment | 28 |
| Fire Extinguisher | 28 |
| Steering / Throttle Cables | 28 |
| Tether Cord / Engine Stop Button | 29 |
| Clothing | 29 |
| Obstacles | 29 |
| OPERATING INSTRUCTIONS | 30 |
| Principle of Operation | 30 |
| Jet Pump Nozzle Adjustment | 31 |
| Boarding from a Dock or in Shallow Water | 31 |
| Starting the Engine | 31 |
| Boarding in Deep Water | 33 |
| Rough Water Operation | 34 |
| Crossing Waves | 35 |
| Docking | 35 |
| Beaching | 36 |
| Shutting Off the Engine | 36 |

| | |
|---------------------------------------------------------------------|-----------|
| POST-OPERATION CARE | 37 |
| General Care..... | 37 |
| Additional Care for Unclean Water or Salt Water | 37 |
| SPECIAL PROCEDURES | 41 |
| Engine Overheat | 41 |
| Jet Pump Water Intake and Impeller Cleaning | 41 |
| Capsized Watercraft | 42 |
| Submerged Watercraft | 42 |
| Towing the Watercraft | 43 |
| Low-Charge Battery Condition | 43 |
| MAINTENANCE | 44 |
| Lubrication | 44 |
| Periodic Inspection | 46 |
| Periodic Inspection Chart | 47 |
| Spark Plug Cleaning and Adjustment | 48 |
| Throttle and Choke Cable Inspection | 48 |
| Carburetor Adjustment..... | 49 |
| Fuel and Oil Filters | 49 |
| Steering / Jet Pump Nozzle Adjustment | 50 |
| Vacuum Bailer Pick-Ups and Water Tank Trap Drains | 50 |
| Fuse Cap | 51 |
| Battery | 51 |
| General Inspection and Care | 53 |
| TRANSPORTATION, STORAGE AND PRE-SEASON PREPARATION | 54 |
| Transportation..... | 54 |
| Storage | 54 |
| Pre-Season Preparation | 60 |
| TROUBLESHOOTING..... | 62 |
| ACCESSORIES AND SERVICE PRODUCTS | 64 |
| SPECIFICATIONS | 68 |
| SI METRIC INFORMATION GUIDE..... | 70 |

FOREWORD

The *Operator's Guide* and *Safety Handbook* have been prepared to acquaint the owner / operator or passenger of this personal watercraft with the various watercraft controls, maintenance and safe riding instructions. Each is indispensable for the proper use of the product, and should be kept in a waterproof bag with the watercraft at all times.

For any questions pertaining to the warranty and its application, please consult the WARRANTY QUESTIONS AND ANSWERS section in this guide, or an authorized SEA-DOO dealer.

This guide uses the following symbols to emphasize particular information.

◆ **WARNING** : Identifies an instruction which, if not followed, might cause serious personal injuries including the possibility of death.

▼ **CAUTION** : Denotes an instruction which, if not followed, might severely damage the watercraft and / or components.

○ **NOTE** : Indicates supplementary information needed to fully complete an instruction.

Although the mere reading of such information does not eliminate the hazard, the understanding and application of the information will promote its correct use.

The information and components / system descriptions contained in this guide are correct at the time of publication. Bombardier Inc. however, maintains a policy of continuous improvement of its products without imposing upon itself any obligation to install them on products previously manufactured.

Bombardier Inc. reserves the right at any time to discontinue or change specifications, designs, features, models or equipment without incurring obligation.

The illustrations show the typical construction of the different assemblies and, may not represent the full detail or exact shape of the parts which have the same or a similar function.

Specifications are given in the SI metric system with the SAE U.S. equivalent in parenthesis. Where precise accuracy is not required, some conversions are rounded off for easier use.

A *Shop Manual* can be obtained for complete service, maintenance and repair information.

◆ **WARNING** : The engines and the corresponding components identified in this guide should not be utilized on product(s) other than those it is designed for. Maintenance procedures and specified tightening torques must be strictly adhered to. Never attempt repairs unless the appropriate tools are available. This watercraft is designed with parts dimensioned in the metric system. All fasteners are metric and must not be replaced by customary SAE U.S. fasteners. Mismatched or incorrect fasteners could cause damage to the watercraft or possible personal injury.

SAFETY

PLEASE READ AND UNDERSTAND ALL WARNINGS AND CAUTIONS IN THIS GUIDE, ON THE WATERCRAFT AND IN THE *SAFETY HANDBOOK*.

Prior to operating the watercraft, thoroughly read and understand the *Operator's Guide*, it will give necessary knowledge required to adequately operate this watercraft.

About the Navigation Laws and Regulations

- ◆ Check local and federal boating laws and regulations in the area where the watercraft is to be used. It is recommended to follow a boating safety course.

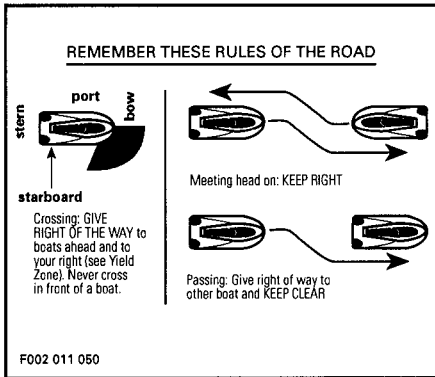

- ◆ Operator and passenger must always wear a lifejacket. It is recommended to use gloves, deck shoes / booties, protective glasses and a wet suit to help protect users against possible injuries.

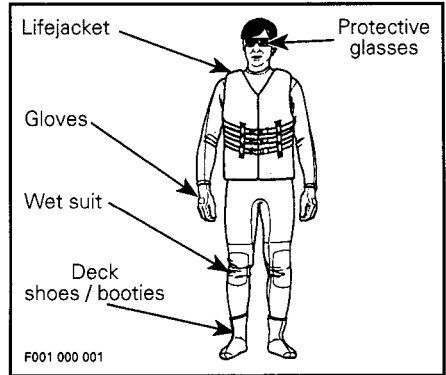

- ◆ An approved fire extinguisher must be present in the watercraft (space is provided in storage compartment).
- ◆ Operation by an unqualified minor is not recommended. A responsible adult should instruct and supervise a minor operating the watercraft.
- ◆ This watercraft is not designed for night-time operation.
- ◆ Never operate the watercraft after consuming alcohol and / or drugs.

Watercraft Operation

- ◆ For safety reasons and proper care, always perform DAILY PRE-OPERATION CHECKS as specified in this guide before operating the watercraft.
- ◆ Operator should be sitting on the watercraft and firmly holding the handlebar before starting the engine.
- ◆ Always securely attach the tether cord to the operator's lifejacket.
- ◆ Throttle and steering mechanisms must be checked for free movement before starting engine.
- ◆ Check fuel/oil levels and battery condition before operating the watercraft.

-
- ◆ When starting or operating the engine, do not touch any electrical part.
 - ◆ The watercraft engine is stopped by pressing the engine stop button until engine stops or by pulling the tether cord. If the engine is stopped because of an equipment malfunction, the source of this malfunction should be determined and corrected before restarting the engine.
 - ◆ Watercraft should not be operated in less than 60 cm (2 ft) of water. Otherwise damage may occur to watercraft.
 - ◆ Do not run the watercraft to the beach. Refer to OPERATING INSTRUCTIONS under **Beaching** in this guide.
 - ◆ It is not recommended to operate the watercraft within or around the surfline, watercraft control may be impaired.
 - ◆ Be careful before beginning a sharp turn, other craft operators may not expect that this watercraft can turn quickly.
 - ◆ Always keep in mind that as the throttle lever is released, less directional control will be available. At idle or engine stop, there is no directional control. To turn the watercraft, steering must be turned and throttle applied.
 - ◆ The operator should practice solo operation prior to giving a ride to passenger.
 - ◆ Watercraft carrying capacity is 160 kg (352 lb). Riding with a passenger makes the watercraft handle differently and requires greater skill.
 - ◆ Always check injection oil reservoir level when refueling.
 - ◆ The operator and passenger should keep their feet on the watercraft floorboard. The passenger should always hold the seat strap or rear grab handle (if applicable). Do not give a ride to someone if their feet can not reach the floorboard..
 - ◆ A towrope should be kept at all time in the watercraft storage compartment.
 - ◆ Always stop engine before refueling. Fuel is highly flammable and explosive under certain conditions. Refuel in a well ventilated area. Never, refuel while smoking or in vicinity of open flame. If fuel fumes are noticed, the cause should be determined and corrected without delay.
 - ◆ When the engine is running, be careful not to have hands, feet or any part of clothing close to the jet pump water intake.
 - ◆ To prevent accidental engine starting, always remove tether cord. Particularly when cleaning jet pump water intake area.
 - ◆ Remove debris from jet pump water intake only when engine is turned off and tether cord is removed. Never insert any object in the jet pump water intake or outlet.
 - ◆ An inexperienced operator should practice how to get aboard close to shore first before venturing into deep water.
 - ◆ Wave or wake jumping is dangerous and may be illegal.
 - ◆ Unless in an emergency, do not perform 180° or 360° turns at speed.
 - ◆ Watch for dangerous near-surface or underwater obstacles / rocks / weeds particularly while riding in shallow water.
 - ◆ Do not operate near swimmers.
 - ◆ When riding far it is recommended to be accompanied by another craft. Watch for and keep a safe distance from other craft.

Maintenance

- ◆ After salt water use, particular care and lubrication have to be performed to neutralize salt action on watercraft and components. Refer to **POST-OPERATION CARE** under **Additional Care for Unclean Water and Salt Water** in this guide.
- ◆ Since the engine cooling is in effect only when the watercraft is in the water, it is not recommended that the engine be allowed to idle for more than one minute without water supply. Prolonging such idling might cause engine damage as well as seal damage on drive shaft seal carrier.
- ◆ When inspecting the hull / jet pump, always rotate watercraft **counterclockwise** (seen from the rear). Rotating watercraft clockwise could allow residual water in the tuned pipe to enter the engine and cause engine damage.
- ◆ Maintain the watercraft in top mechanical condition at all times.
- ◆ Installation of parts other than original equipment is not recommended. Avoid adding on accessories that alter the basic watercraft configuration including change in components location, altering vent tubes, etc.
- ◆ Whenever the watercraft is left outdoors for a long period, it is strongly recommended to protect the watercraft from the weather with a SEA-DOO cover.
- ◆ Only perform procedures as detailed in this guide. Unless otherwise specified, engine must be turned off and tether cord removed from switch for all maintenance.
- ◆ Should removal of a locking device be required when undergoing repair / disassembly, always replace with new ones. Tighten fasteners as specified in the applicable *Shop Manual*.

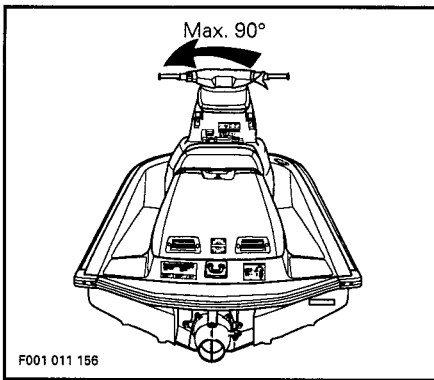

- ◆ Should water get into the engine, immediately follow the procedure pertaining to **Submerged Watercraft** in the **SPECIAL PROCEDURES** section as specified in this guide. Should water be left in the engine for more than a few hours, engine internal parts will be damaged.

SEA-DOO WATERCRAFT (NORTH AMERICAN) LIMITED WARRANTY _____

(MODEL 5806 / 5807 / 5808 / 5852 / 5861 AND 5813)

1 - PERIOD

BOMBARDIER® INC. as manufacturer, warrants FROM THE DATE OF FIRST CONSUMER SALE, every SEA-DOO Watercraft, models 5806 / 5807 / 5808 / 5852 / 5861 and 5813, sold as NEW, UNUSED, and **predelivered by an authorized NORTH AMERICAN SEA-DOO Watercraft dealer for a period of :**

- 12 consecutive months for private use owners.
- 90 consecutive days for commercial use owners.

2 - WHAT BOMBARDIER WILL DO

BOMBARDIER will repair and / or replace, at its option **c** **genuine Bombardier components found defective in material and / or workmanship** (under normal use and service), with a genuine BOMBARDIER component without charge for parts or labor, at any authorized NORTH AMERICAN SEA-DOO dealer during said warranty period. All parts replaced under warranty become the property of BOMBARDIER INC.

3 - CONDITIONS TO HAVE WARRANTY WORK PERFORMED

Present to the servicing dealer, the BOMBARDIER warranty registration card or proof of purchase received from the selling dealer at time of purchase.

4 - EXCLUSIONS - ARE NOT WARRANTED

- Normal wear on all items such as, but not limited to :
 - Impellers, spark plugs, fuel filters.
 - Gel coat stress cracks.
- Damage caused by failure to provide proper maintenance as detailed in the *Operator's Guide*. The labor, parts and lubricants costs of all maintenance services, including tune-ups or adjustments will be charged to the owner.
- Damage resulting from running the watercraft out of the water.
- Damage resulting from improper repairs, modification, racing or use of non-approved parts.
- Losses incurred by the watercraft owner other than the parts and labor, such as, but not limited to, transportation, towing, telephone calls, taxis or any other incidental or consequential damage.
- Damage resulting from accident, fire or other casualty, misuse, abuse or neglect.
- Damage / rust / corrosion / premature wear caused by water ingestion or sand / stone infiltration, or cavitation.

5 - BATTERY WARRANTY

- 12 consecutive months (pro-rated).
100 % warranty coverage including parts and labor for the first six months will start on the date the watercraft was sold. The remainder of the 12 month period will be pro-rated as follows :
 - 60 % for the seventh (7) month
 - 50 % for the eighth (8) month
 - 40 % for the ninth (9) month
 - 30 % for the tenth (10) month
 - 20 % for the eleventh (11) month
 - 10 % for the twelfth (12) month

6 - EXPRESSED OR IMPLIED WARRANTIES

This warranty gives you specific rights, and you may also have other legal rights which may vary from state to state, or province to province.

Where applicable this warranty is expressly in lieu of all other expressed or implied warranties of BOMBARDIER, its distributors and the selling dealer, including any warranty of merchantability or fitness for any particular purpose: otherwise the implied warranty is limited to the duration of the warranty. However, some states or provinces do not allow limitations on how long an implied warranty lasts, so the above limitations may not apply.

Neither the distributor, the selling dealer, nor any other person has been authorized to make any affirmation, representation or warranty other than those contained in this warranty, and if made, such affirmation, representation or warranty shall not be enforceable against BOMBARDIER or any other person.

Some states or provinces do not allow the exclusion or limitation of incidental or consequential damages, so the above limitation or exclusion may not apply.

BOMBARDIER INC. reserves the right to modify its warranty policy at any time, being understood that such modification will not alter the warranty conditions applicable to watercraft sold while the above warranty is in effect.

7 - CONSUMER ASSISTANCE PROCEDURE

If a servicing problem or other difficulty occurs, we suggest the following :

1. Try to solve the problem at the dealership with the Service Manager or Owner.
2. If not possible, contact the area distributor listed in your *Operator's Guide*.

BOMBARDIER INC.

Valcourt, Québec,

Canada JOE 2LO

October 1st, 1992

®*Trademarks of Bombardier Inc.

DISTRIBUTORS' LIST

NORTH AMERICA

U.S.A.
Continental U.S.A.
except Alaska

BOMBARDIER CORPORATION
7575 BOMBARDIER COURT
P.O. BOX 8035
WAUSAU, WI
54402-8035
Phone : (715) 842-8886

Alaska

THE BRYANT CORPORATION
P.O. BOX 389
WOODINVILLE, WA 98072
Phone : (206) 483-0110

CANADA :
Ontario
Quebec

BOMBARDIER INC.
SEA-DOO SERVICE DEPARTMENT
VALCOURT, QUEBEC,
CANADA J0E 2L0
Phone : (514) 532-2211

Alberta
British Columbia
Manitoba
North West Territories
Saskatchewan
Yukon

BROOKS EQUIPMENT LTD
1616 KING EDWARD ST.
P.O. BOX 985
WINNIPEG, MANITOBA R3C 2V8
Phone : (204) 633-7247

New-Brunswick
Newfoundland
Nova Scotia
Prince Edward Island

BELL-CHARLES R.
P.O. BOX 1050
RIVERSIDE DRIVE
CORNER BROOKE, NFLD A2H 6J3
Phone : (709) 634-3533

WARRANTY QUESTIONS AND ANSWERS

Q. Why must my watercraft be registered at the factory ? After all I do have my original invoice as proof of when I purchased my watercraft ?

A. *Your warranty is valid at any authorized dealer of the product. Your registration is the key element in providing the servicing dealer with the necessary data to complete warranty claim forms.*

The federal government requires each manufacturer and dealer to maintain a complete up-to-date list of all first purchasers against the possibility of a safety-related defect and recall. This list is compiled from the purchase registrations sent to BOMBARDIER INC. by the selling dealer at the time of your purchase. If you have a change of address after the purchase of your new SEA-DOO, please advise us of your new address by sending a post-card listing your model number, dealer number (or dealer's name) as it is shown on your warranty card, your name and new mailing address.

Q. What costs are my responsibility during the warranty period ?

A. *The customer's responsibility includes all costs of normal maintenance services non-warranty repairs, accident and collision damage.*

Q. What is cavitation ?

A. *This phenomenon is caused by a part travelling at high speed in a fluid (ex. : an impeller in water). The heat/bubbles generated in some areas are enough to draw microscopic particles from the material. Cavitation will increase if there are scratches or dents in the housing / impeller or if the wear ring is worn.*

Q. Does warranty cover the jet drive system components ?

A. *Yes, if components replacement is not due to cavitation or normal wear. Ex. : The impeller has to be considered a wear item since tiny particles and sand contained in the water will eventually cause some wear. This situation occurs most often when the vehicle is driven in shallow water where rocks and debris can be drawn into the pump.*

In order to extend the service life of the impeller housing, we have developed a replaceable wear ring around the impeller. It is made of plastic, therefore it may wear with use and should be replaced. This is a convenient feature and inexpensive to replace. This replacement is considered normal maintenance and not covered by warranty.

Q. What are some examples of neglect or abuse ?

A. *These terms are general and overlap each other in areas. Specific examples include ; the engine running out of oil, operating the watercraft with a broken or damaged part, which causes another part to fail and so on. If you have any specific questions on operation or maintenance, please contact your SEA-DOO watercraft dealer for advice.*

Q. Does the warranty cover incidental costs such as transportation due to a failure ?

A. *No. The warranty is limited to repair of the SEA-DOO watercraft itself.*

Q. May I perform any or all of the recommended maintenance shown in the *Operator's Guide* instead of having the dealer do them ?

A. *Yes, if you are a qualified mechanic and follow the procedures specified in the Operator's Guide and Shop Manual. We do recommend however that the critical adjustments to timing and carburetion be done by a SEA-DOO dealer.*

Q. Will the warranty be voided or cancelled if I do not operate or maintain my new SEA-DOO exactly as specified in the *Operator's Guide* ?

A. *No. The warranty on a new SEA-DOO cannot be "voided" or "cancelled". However, if a particular failure is caused by operation or maintenance other than as shown in the Operator's Guide, that failure may not be covered under warranty.*

Q. What responsibility does my dealer have under this warranty ?

1. *Completely set up every new SEA-DOO watercraft before sale*
2. *Explain the operation, maintenance and warranty requirements to your satisfaction at the time of sale. In addition, each SEA-DOO dealer is held responsible for set-up, service and warranty repair work.*

Customer Service

If your SEA-DOO requires warranty service, you must take it to any authorized SEA-DOO dealer. Be sure to bring your warranty registration card or other valid proof of the original date of purchase. If a question or problem arises regarding warranty, first contact the owner of the SEA-DOO dealership.

Since all warranty matters are handled at the dealer level this person is in the best position to help you. If you are still not satisfied and require additional assistance, please write to your distributor, refer to DISTRIBUTOR'S LIST in this *Operator's Guide*.

REGISTRATION NUMBER LOCATION _____

All personal watercraft are required by federal law to be registered and legally numbered.

Due to space availability for proper display of registration number, refer to following illustration for location.

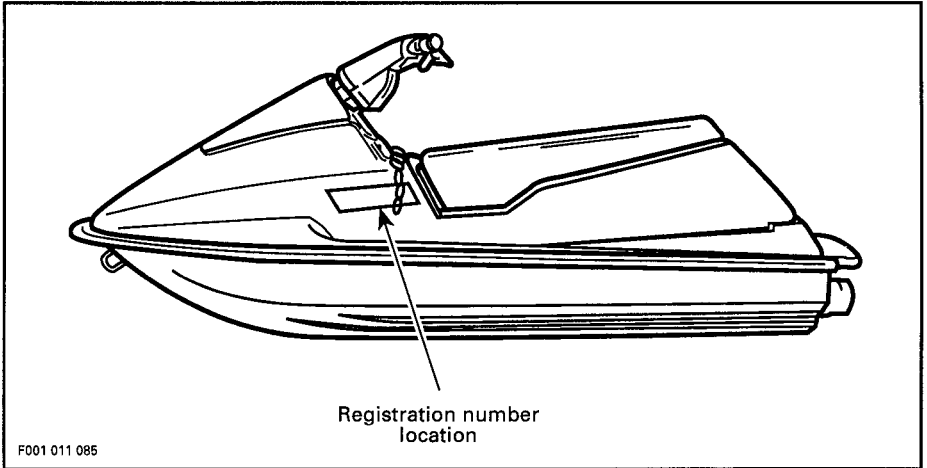

IDENTIFICATION OF COMPONENTS

Identification Numbers

The main components of the watercraft (engine and hull) are identified by different serial numbers. It may sometimes become necessary to locate these numbers for warranty purposes or to trace the watercraft in the event of theft.

The Engine Identification Number (E.I.N.) is located on the upper side of the magneto housing.

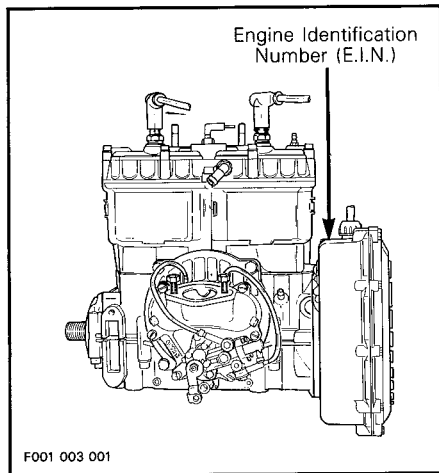

The Hull Identification Number (H.I.N.) is located at right hand rear side of hull.

The watercraft model number can be found on U.S. Coast Guard approved label located on left hand side of stern (rear) eyelet.

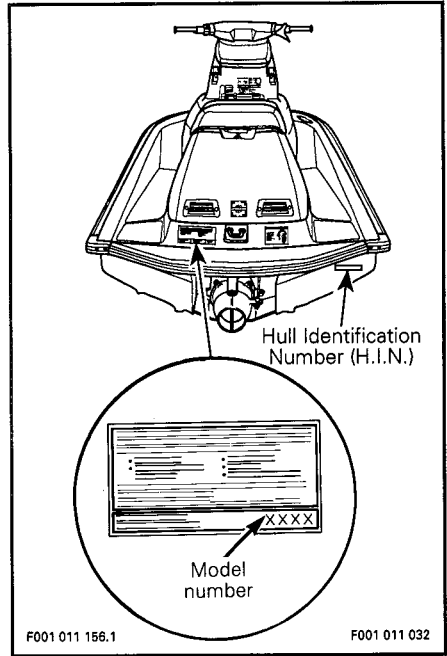

Controls and Components Location

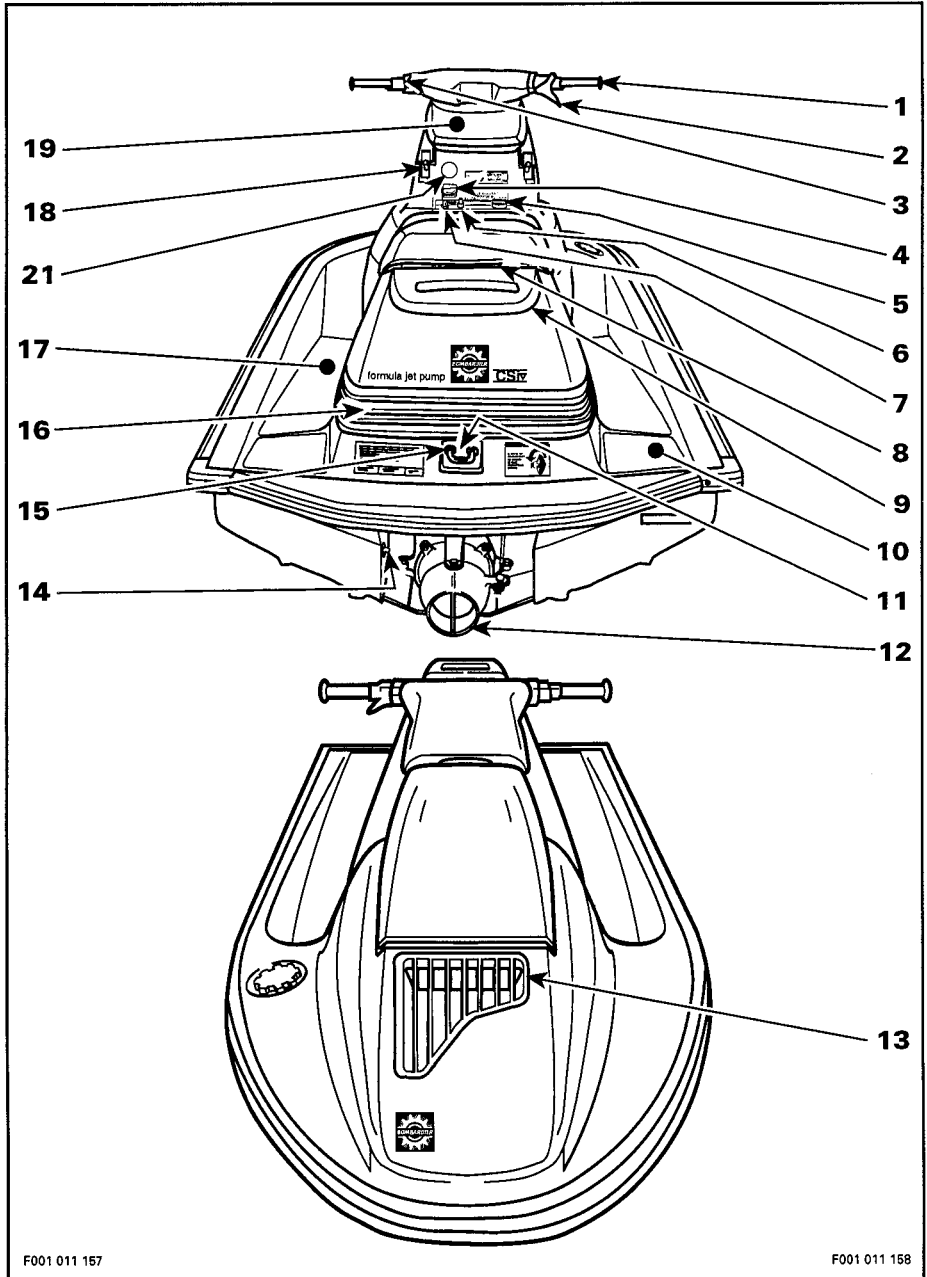

Controls and Components Location

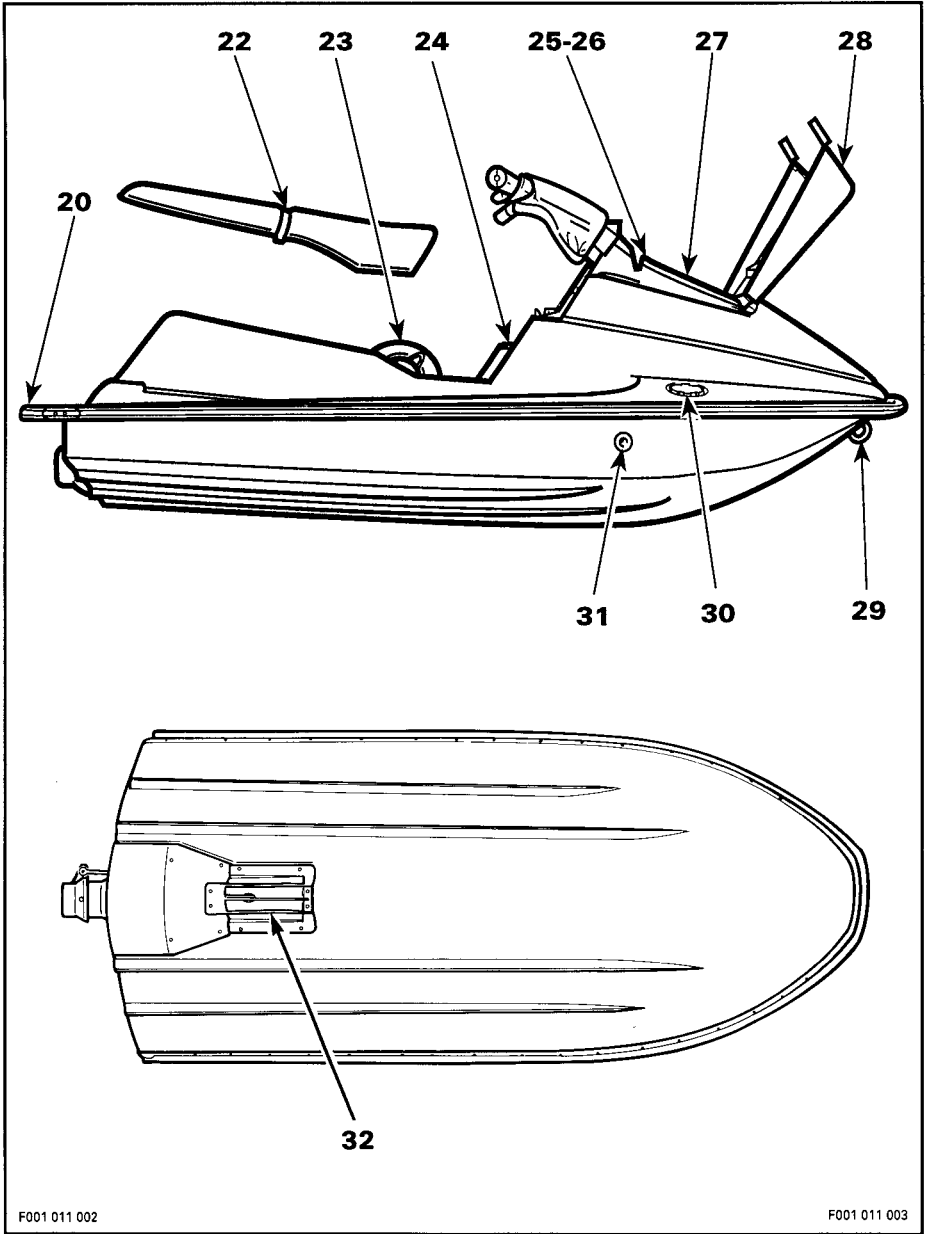

F001 011 002

F001 011 003

1) Handlebar

The handlebar controls the direction of the watercraft. Turning the handlebar to the right steers the watercraft to the right and inversely.

2) Throttle Lever

It controls the speed of the engine and therefore, the speed of the watercraft. When squeezed, watercraft accelerates. When fully released, engine automatically returns to idle speed and watercraft is gradually stopped by water drag.

3) Engine Stop Button

Located on left side of handlebar, this button is intended to stop engine when necessary. To use, fully release throttle lever then press the button.

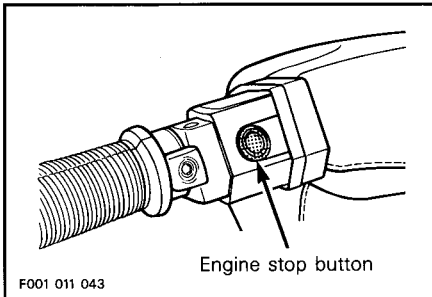

◆ **WARNING:** When the engine is stopped, watercraft directional control is not available.

4) Choke Knob

The choke is provided to supply a richer fuel / air mixture when starting a cold engine. When the knob is completely pulled, the choke is fully applied. The use of the choke is not recommended with a warm engine.

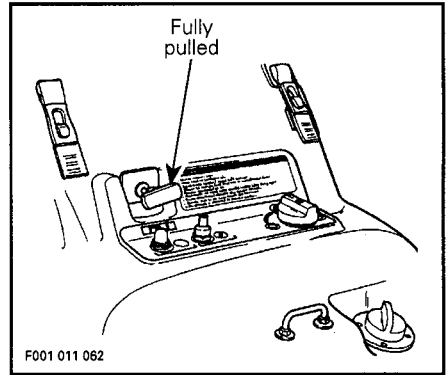

5) Fuel Tank Valve

A three-position rotating valve, OFF, ON, RESERVE :

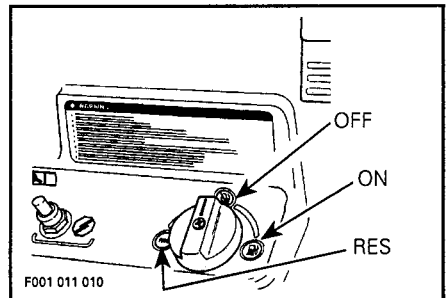

OFF : Stop fuel supply to carburetor.

▼ **CAUTION:** Turn valve to OFF when watercraft is not operated.

ON : Allows fuel to flow to carburetor. This is the normal position for operation of watercraft. With a full fuel tank, the watercraft can run approximately 1.5 hour at full throttle before running out of fuel (in the ON position).

RES : Use when the watercraft has run out of fuel in the ON position. Allow approximately 15 minutes operation at full throttle before running out of fuel.

◆ **WARNING** : Always refill the fuel tank at the first opportunity. After refueling, turn the fuel valve to the ON position for further operation.

6) Tether Cord Switch

Pulling the tether cord from the switch stops the engine operation. Attach the tether cord to the operator's lifejacket and snap the cap to the switch before starting the engine.

▼ **CAUTION** : Always remove tether cord when leaving watercraft.

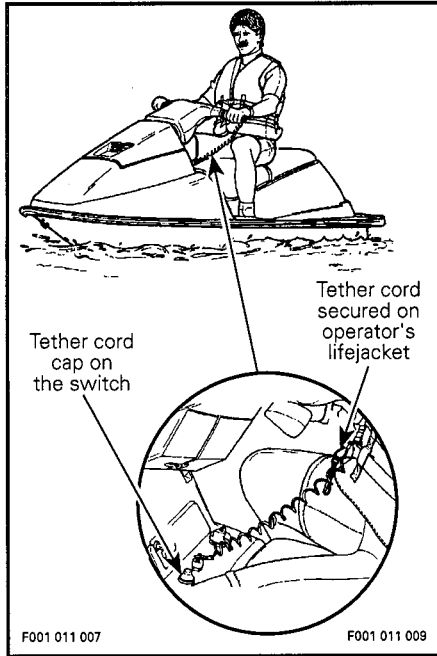

◆ **WARNING** : Should the engine be stopped, watercraft directional control is not available.

7) Starting Button

To start engine, depress and hold the button. Release immediately after engine is started.

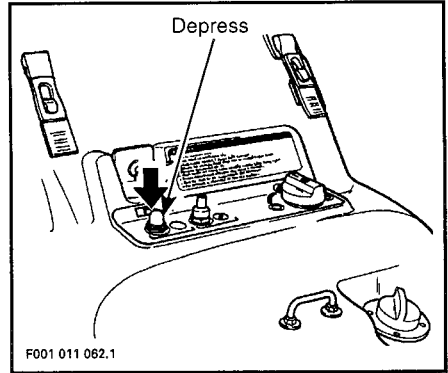

○ **NOTE** : Engine will not start if the tether cord is removed.

8) Seat Opening

Removing the seat allows access to the engine compartment and to oil reservoir cap and dipstick.

The seat latch is located at the rear end and underneath the seat.

To remove seat, pull the latch lever upward and hold. Lift and pull the seat rearward.

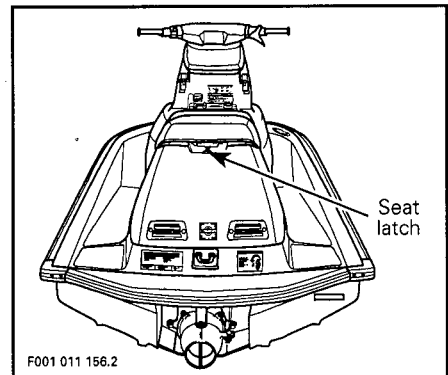

When reinstalling the seat, insert seat front tab into body hook.

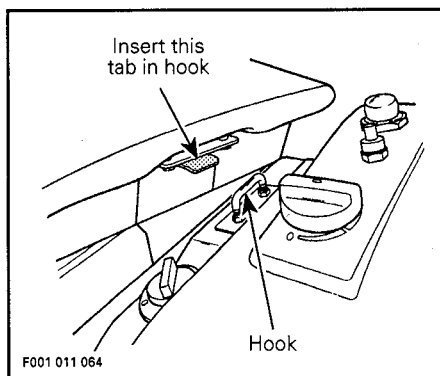

Pull latch lever to insert it over the rear lock pin. Release latch lever then firmly push on rear of the seat to relatch.

○ **NOTE:** Periodically verify the seat hooks upper nuts and lock nuts, tighten if needed. Make sure seat is securely latched.

9) Rear Grab Handle (SPX model only)

Provides a handhold for boarding when needed and a handhold for the passenger.

▼ **CAUTION:** Never use the grab handle to tow anything or to lift the watercraft.

10) Boarding Pads

Provided a cushioned surface for the knees when boarding from rear of watercraft.

11) Cooling System Bleed Outlets

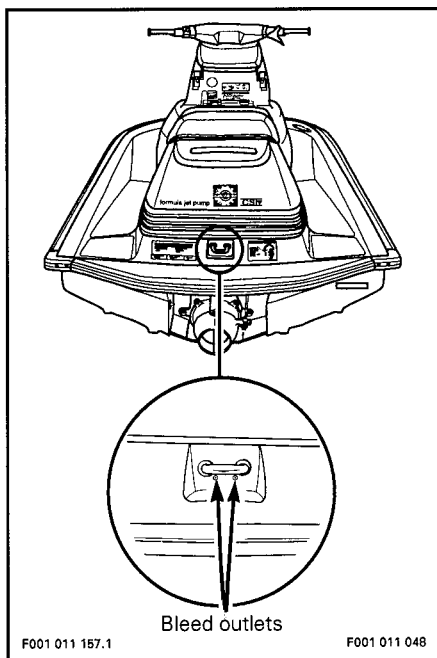

When engine is running, water must flow from these holes. This allows air in tuned pipe and in engine water jacket to escape. It also indicates that water is circulating in the cooling system.

▼ **CAUTION:** Should water not flow from these outlets a few seconds after engine starts, immediately stop engine and refer to **POST-OPERATION CARE** and look for cooling system flushing or refer to an authorized dealer for servicing.

12) Jet Pump Nozzle

It is turned from side to side via rider input at the handlebar. This provides watercraft directional control when engine is running.

The jet pump nozzle is adjustable. This adjustment is obtained by tilting the nozzle.

▼ **CAUTION :** Never use steering nozzle as a supporting point to board the watercraft or to lift it.

13) Air Intake Opening

This is where air enters to supply the engine and ventilate the engine compartment. It incorporates a baffle to separate water from air, but if the air intake opening is kept under water for a long period water will get inside bilge.

14) Bilge Drain Plug

Should water be found in the bilge, it can be easily drained by removing this plug.

▼ **CAUTION :** Remove watercraft from water prior to removing the drain plug.

Release the lever then remove plug.

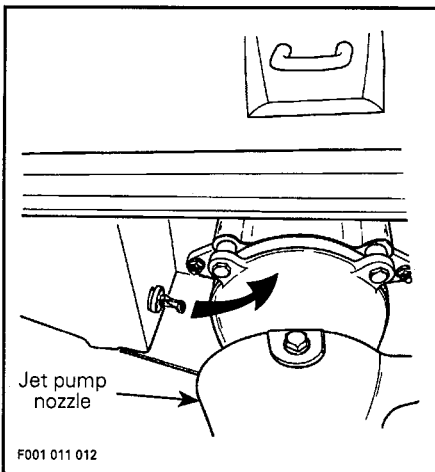

Tilt the watercraft slightly to the rear so that the water can completely flow out of the bilge.

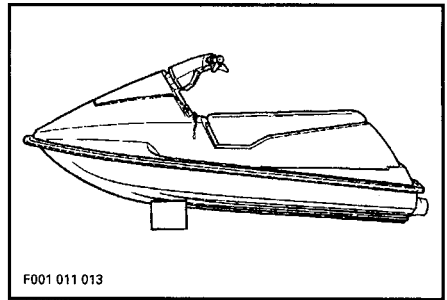

○ **NOTE :** Should the plug become loose in its hole, hold the plug then with the lever pulled, turn the lever clockwise to tighten (counterclockwise to loosen). Adjust to have a watertight fit.

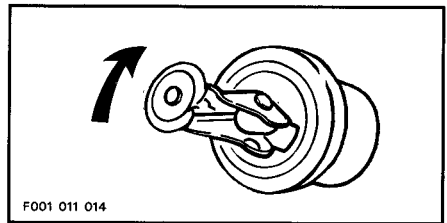

Reinstall bilge drain plug and fully push the plug lever to locked position.

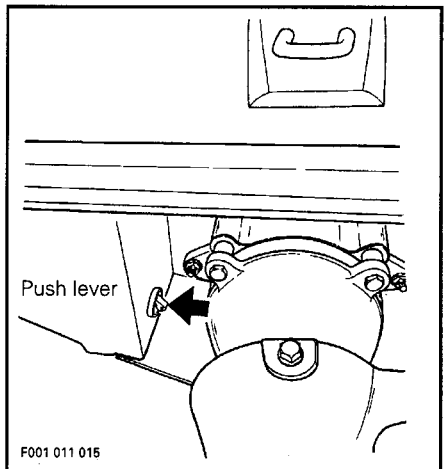

◆ **WARNING** : Always make sure bilge drain plug is properly installed in the drain hole and lever is safely locked.

15) Stern Eyelet

Eyelet can be used for mooring, towing and as a tie-down point during transportation.

16) Rear Vent Grill

Allows air to get in or out depending on engine operation.

▼ **CAUTION** : If grill is kept below water level for a long period (e.g.: when boarding a passenger) water will enter the bilge and possibly the engine.

17) Floorboard

It is conveniently covered with antiskid surface. User's feet should rest on the floorboard when riding.

18) Cover Latches

Pull down the latches to open the storage compartment cover. Always re-latch.

19) Overheating Beeper

In the event the engine overheats, a beeper (continuous sound) will warn the operator. Stop and refer to an authorized dealer.

20) Boarding Platform

Provide a large surface for easy boarding from rear of watercraft.

21) Electric Fuel Level Gauge / Injection Oil Level Pilot Lamp (SPX model only)

Located on console, the needle shows the amount of fuel in the fuel tank and a light turns on when level is low in oil reservoir.

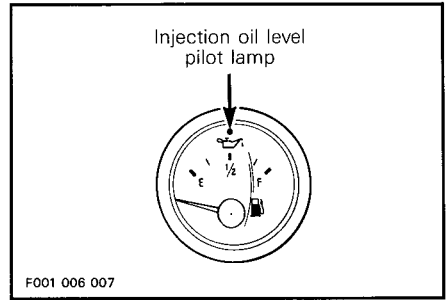

22) Seat Strap

The seat strap provides a handhold when needed for boarding and a handhold for the passenger.

23) Engine Compartment

○ **NOTE** : Seat has to be removed to access engine compartment.

This is where the engine, fuel / oil filters, battery, fuse, jet pump drive shaft, vacuum bailer picks-ups, etc., are located.

◆ **WARNING** : When starting or operating the engine, do not touch any electrical part. Never leave any object, rag, tool, etc., in the engine compartment or in the bilge.

24) Oil Injection Reservoir Gauge / Cap

○ **NOTE** : Seat has to be removed to expose oil cap.

Unscrew the cap counterclockwise then pull to expose the dipstick.

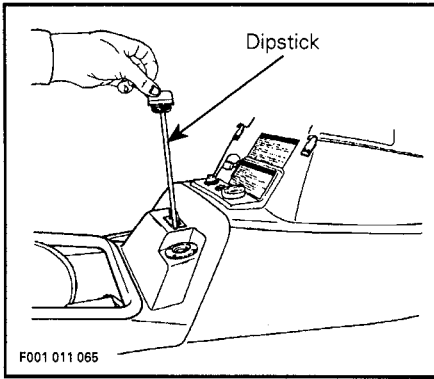

The dipstick indicates the amount of oil to be added in the reservoir. Oil level should be maintained between FULL and ADD marks. Before checking oil level, place the watercraft level, then wipe the dipstick and insert it in the reservoir neck. Do not screw cap. Remove dipstick and read the level.

25) Tool Kit

Contains tools needed to perform basic watercraft maintenance.

26) Operator's Guide

Should be kept in a waterproof bag and remain with the watercraft at all times, even at time of resale.

27) Storage Compartment

A convenient watertight, removable basket to carry personal articles. Ideal location for spare spark plugs, tow-rope, first aid kit, etc. Reinstall basket as shown.

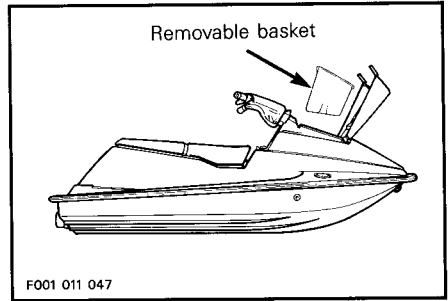

◆ **WARNING:** Never leave any heavy or breakable object in the storage basket. Never store or carry anything below basket.

This area is the preferred location to store an approved extinguisher. The fire extinguisher holder is installed in the rear center portion of the basket. This holder contains tool kit, *Operator's Guide* and it has a compartment to carry personal articles. Fire extinguisher should not be left loose in the storage compartment.

28) Storage Compartment Cover

Gently lift cover. It gives access to the storage compartment. Always secure cover latches after closing.

29) Bow Eyelet

Eyelet can be used for mooring, towing and as a tie-down point during transportation.

30) Fuel Tank Cap

Unscrew the cap counterclockwise to allow fuel tank filling. Fully tighten when finished.

◆ **WARNING:** Never use a lit match or open flame to check fuel level.

31) Water Tank Trap Drains

If water enters the air intake opening, a water tank trap with a baffle separates water from the air then evacuates the water through two drain hoses, one on each side of the hull.

▼ **CAUTION** : Unusual maneuvers such as circles with the nose of the watercraft under water will eventually fill the bilge and possibly cause engine damage.

32) Jet Pump Water Intake

The water is drawn up by the impeller through this opening. The impeller and the drive shaft are protected by a grill.

FUEL / OIL AND BREAK-IN

Recommended Fuel

Use regular unleaded gasoline with 87 octane (Ron + Mon / 2) specification.

○ **NOTE** : Look on service station pump sticker for octane specification.

○ **NOTE** : Do not mix oil with fuel except at engine break-in. Refer to **Engine Break-In** in this section. Always check injection oil reservoir level when refueling.

The use of good quality fuel is necessary. A well known fuel brand is highly recommended.

▼ **CAUTION** : The use of a poor quality fuel can result in watercraft performance deterioration and damage to fuel system and engine components. Refer to an authorized dealer immediately.

Pour fuel slowly so that air can escape from the reservoir and prevent fuel flowback.

Do not enter the spout too far in filler neck.

Fill fuel tank to bottom of filler neck. Do not overfill.

Fully tighten fuel tank cap and wipe off any fuel spillage.

◆ **WARNING** : Do not lean the watercraft to allow more fuel to fill the fuel tank. The tank design makes provision for fuel expansion of about 5%. If this area is filled, fuel will expand and may come out through fuel vent hose. Keep watercraft horizontal while fueling. Always stop the engine before refueling. Fuel is flammable and explosive under certain conditions. Always work in a well ventilated area. Do not smoke or allow open flames or sparks in the vicinity. Never experiment with other fuels or fuel ratios. Never use fuel containing alcohol, methanol or similar products includ-

ing naphtha. The use of unrecommended fuel can result in watercraft performance deterioration and damage to critical parts in the fuel system and engine components. Never top off the fuel tank and leave watercraft in the sun. As temperature increases, fuel expands and might overflow. Always wipe off any fuel spillage from the watercraft.

Recommended Oil

Use only SEA-DOO INJECTION OIL (P / N 293 600 005 - 1L or 293 600 004 - 4L) which is available from authorized dealers. It is a blend of specially selected base oils and additives which provides outstanding lubrication, engine cleanliness and minimum spark plug fouling.

If SEA-DOO INJECTION OIL is not available, substitute with BOMBARDIER SNOWMOBILE INJECTION OIL (P / N 496 013 300 - 1L) or BOMBARDIER BLIZZARD OIL (P / N 496 013 500 - 500 mL).

○ **NOTE** : High quality low ash API TC injection oil for two cycle engines can be used if SEA-DOO INJECTION OIL is not available.

▼ **CAUTION** : Never use straight mineral oil and never mix with outboard oil. Do not use NMMA TC-W or TC-WII outboard motor oils or other ashless type two cycle oils. Avoid mixing different brands of API TC oil as resulting chemical reaction may cause severe engine damage.

Oil Injection System

This watercraft features an oil injection system which does not require manual fuel / oil mixing.

Oil level should be maintained between FULL and ADD of dipstick marks. To check, remove seat to expose oil cap,

unscrew cap, wipe dipstick then insert in the reservoir neck. Do not screw cap. Remove dipstick and read the level. Add oil as necessary.

Use a flexible funnel to pour oil into reservoir. Wipe off any oil spillage.

○ **NOTE** : Always carry a 500 mL of SEA-DOO INJECTION OIL to prevent emergency.

▼ **CAUTION** : Always maintain a sufficient amount of injection oil in the oil reservoir. Check and refill every time you refuel. Do not overfill. If the engine runs out of oil, severe engine damage will occur. If the oil tank is found almost empty air can enter in the system and it must be bled. Immediately refer to an authorized dealer to have the oil injection system inspected.

Engine Break-In

With Bombardier-Rotax watercraft engines, a break-in period is required before operating the engine at full throttle. Engine manufacturer recommendation is about 10 operating hours.

During this period, maximum throttle should not exceed $\frac{3}{4}$, however, brief full acceleration and speed variations contribute to a good break-in. Continued wide open throttle accelerations, prolonged cruising speeds and overloading the engine are detrimental during the break-in period.

To assure additional protection during the initial engine break-in, 500 mL of SEA-DOO INJECTION OIL should be added in the fuel tank for the first full fuel tank filling only.

▼ **CAUTION** : Remove and clean spark plugs after engine break-in.

10-Hour Inspection

It is highly recommended that after the first 10 hours of operation, the watercraft be checked by an authorized dealer. This inspection will also provide the opportunity to discuss the unanswered questions you may have encountered during the first hours of operation.

The 10-hour inspection is at the expense of the watercraft owner. Inspection takes approximately 2.5 hours.

| 10-HOUR INSPECTION CHECK LIST | ✓ |
|------------------------------------------------------------------------------|---|
| Engine ignition timing if required | |
| Spark plugs inspection, cleaning and adjustment | |
| Fuel system lines and fasteners / pressurization test | |
| Carburetor adjustment including throttle / choke cables if required | |
| Oil injection system lines and oil filter | |
| Oil injection pump adjustment if required | |
| Engine support and engine rubber mounts | |
| Muffler, battery and reservoir fastening devices | |
| Exhaust system hose clamps torque | |
| Carburetor flange nuts and flame arrester bracket | |
| Steering stem arm locking plate and screw | |
| Steering cable adjustment if required | |
| Hoses condition and fasteners | |
| Bilge lines and filters, check for obstructions | |
| Tether cord switch / engine stop button operation, engine overheating beeper | |
| Electrical connections (starter, battery, etc.) | |
| Impeller shaft reservoir oil replacement | |
| Impeller condition, impeller / wear ring clearance | |
| Drive shaft, lubricate grease fitting at PTO flywheel | |
| Seal carrier, lubricate grease fitting | |
| Water intake grill / hull condition | |
| Inspection of fasteners for tightness | |
| Inspect / clean engine drain tube | |

We recommend that this inspection chart be signed by an authorized dealer

_____ Date of 10-hour inspection

_____ Authorized dealer signature

DAILY PRE-OPERATION CHECKS

Some of the following items may not have been previously covered in this guide, however they will be described in the MAINTENANCE or SPECIAL PROCEDURES section. Please refer to these portions to have more detailed information. Every day the watercraft is to be operated, perform the following checks.

| ITEM | OPERATION | ✓ |
|-----------------------------------|------------------------------------------|---|
| Hull | Inspect. | |
| Jet pump water intake | Inspect / clean. | |
| Bilge | Drain. Ensure plug is secured. | |
| Battery | Inspect electrolyte level / connections. | |
| Fasteners | Visually inspect for tightness. | |
| Fuel / oil reservoirs and filters | Refill / visually inspect. | |
| Engine compartment | Verify fuel / oil system components. | |
| Fire extinguisher | Inspect condition / mounting. | |
| Steering / throttle cables | Check operation. | |
| Tether cord / engine stop button | Check operation. | |

Hull

Inspect hull for cracks or damage.

Jet Pump Water Intake

◆ **WARNING:** Tether cord must always be removed from switch prior to performing the following operation.

Remove weeds, shells, debris or anything else that could restrict the flow of water and damage cooling system or propulsion unit. Clean as necessary. If any obstruction can not be removed, refer to an authorized dealer for servicing.

Inspect leading edges of the impeller, if they have knicks or bends performance will be greatly reduced.

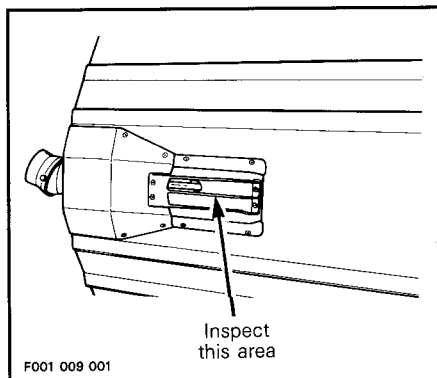

Bilge

Should water be present in the bilge, have the watercraft tilted to the rear and remove drain plug to completely empty the bilge.

◆ **WARNING** : Make sure to take the watercraft out of water prior to removing the drain plug.

Reinstall bilge drain plug and fully push the plug lever to lock.

Battery

Make sure electrolyte level is at the HIGHER level line, that battery connections are not loose and there are no leaks.

○ **NOTE** : Ensure the watercraft is level before checking battery electrolyte level.

◆ **WARNING** : Verify tightness of battery, starter cable terminals.

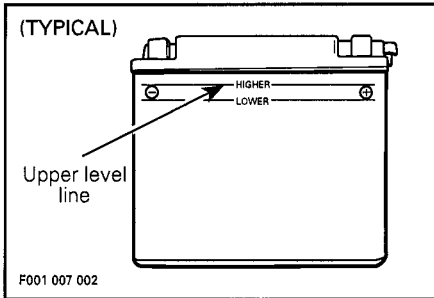

Fasteners

Retighten fasteners as necessary. Ensure all latches are securely locked.

Fuel / Oil Reservoirs and Filters

With the watercraft horizontal, fill the fuel tank to specified level with fuel.

Check the oil level and refill reservoir as necessary.

○ **NOTE** : Always carry a spare 500 mL can of SEA-DOO INJECTION OIL.

Visually inspect oil and fuel filter for foreign particules or water. Refer to an authorized dealer if necessary.

Engine Compartment

Check condition of fuel / oil system components.

◆ **WARNING** : Should any leak be present, do not start the engine or operate the watercraft. Immediately refer to an authorized dealer.

Fire Extinguisher

Make sure it is full, in good condition and well secured.

Steering / Throttle Cables

Check steering operation for free movement. When the handlebar is horizontal, the jet pump nozzle should be in the straight ahead position. Ensure the jet pump nozzle pivots easily while handlebar is turned.

Check throttle lever several times for free and smooth operation without any hesitation through all its stroke. It must return to its initial position immediately after released.

◆ **WARNING** : Perform this check before starting the engine.

Tether Cord / Engine Stop Button

Ensure that both switches operate properly. Start engine and stop it using each switch individually.

◆ **WARNING** : If engine does not stop after one switch has been used, try the other one. If engine still runs, fully pull the choke knob to flood the engine. If it does not work, turn the fuel valve to OFF. Do not operate the watercraft, refer to an authorized dealer.

◆ **WARNING** : Should the engine slowly rotate when cranking, it probably indicates a low battery. Do not operate the watercraft with a lowcharge battery. Always remove battery from watercraft when charging or boosting.

Clothing

Always wear a Coast Guard approved lifejacket. It is also recommended that gloves, wet suit, deck shoes / booties and protective glasses be worn when operating in cooler temperatures.

Obstacles

Verify that the path ahead of the watercraft is clear of other craft or obstacles. Avoid riding close to swimmers. Check local boating laws for safe operation.

◆ **WARNING** : Only start the watercraft once all items have been checked and operate properly.

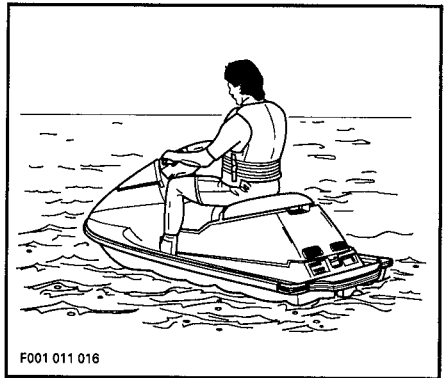

OPERATING INSTRUCTIONS

◆ **WARNING** : Always perform **DAILY PRE-OPERATION CHECKS** before operating the watercraft. Become thoroughly familiar with all controls and the function of each. Should any control or instruction be not fully understood, refer to an authorized dealer.

Principle of Operation

Propulsion

The engine is directly coupled to a drive shaft which, in turn, rotates an impeller. This impeller is accurately adjusted in a housing where the water is drawn up from underneath the watercraft. Then the water flows through the impeller to a venturi. The venturi accelerates the water and produces thrust to move the watercraft. Depressing the throttle lever increases engine speed and therefore watercraft speed.

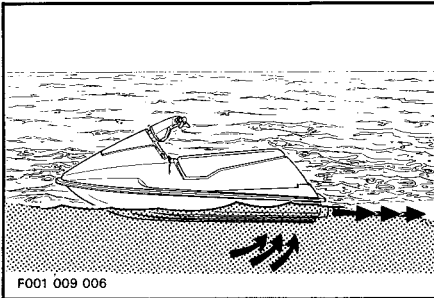

◆ **WARNING** : Whenever the engine is to be started, the operator should always be sitting on the watercraft.

Turning

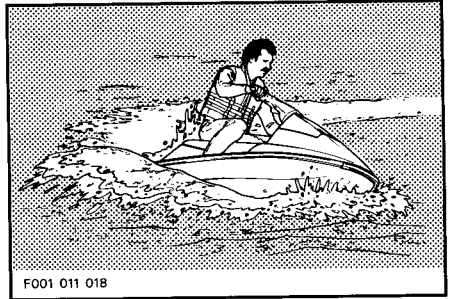

Turning the handlebar pivots the jet pump nozzle which controls the watercraft direction. Turning the handlebar to the right will turn the watercraft to the right and inversely. The throttle must be applied to turn the watercraft.

◆ **WARNING** : Directional control is lost when the throttle is closed. Throttle must be applied and handlebar turned to change the direction of the watercraft. Steering efficiency will differ with a passenger and water condition.

The more the throttle is applied while turning the handlebar, the sharper the turn will be.

Practice these maneuvers to have a good feel of the watercraft operation.

The watercraft behaves differently with a passenger and requires greater skill. The passenger should always grip the seat strap or grab handle (if applicable). Reduce speed and avoid sharp turns. Avoid choppy water conditions when carrying a passenger.

Jet Pump Nozzle Adjustment

The jet pump nozzle has a two-positions adjustment.

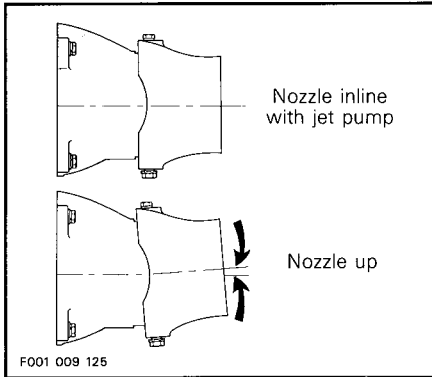

Nozzle Inline with Jet Pump :

For normal load of the driver and passenger.

Nozzle up :

Brings back the watercraft to normal ride position when the load is at front (e.g.: Full fuel and oil tanks, heavy luggage in the storage compartment, one driver sitting up front, no passenger).

Ask your authorized dealer to adjust the nozzle position to suit your most often use conditions.

Boarding from a Dock or in Shallow Water

As with any craft, getting aboard should be done carefully.

When boarding from a dock, slowly place one foot on the watercraft floorboard nearest the dock and, at the same time, transfer the body weight to the other side in order to balance the watercraft while holding the handlebar. Then, bring the other foot over the seat and put it on the other floorboard. Push the watercraft away from the dock.

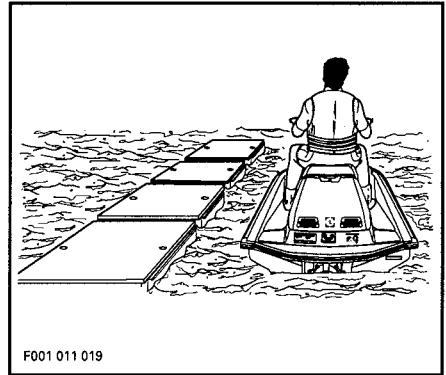

CAUTION : The engine should be started with at least 60 cm (2 ft) of water below the hull.

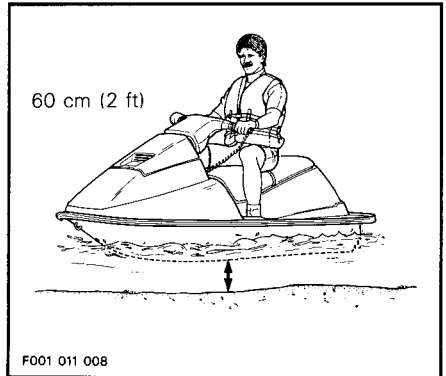

In shallow water, board the watercraft either from the side or the rear.

WARNING : An inexperienced operator should practice how to get aboard close to the shore to simulate deep water boarding. Refer to **Boarding in Deep Water** in this section.

Starting the Engine

Before unloading the watercraft from the trailer, it can be started for about 10 seconds to verify proper operation. Remove stern (rear) strap before starting the engine.

◆ **WARNING** : Do not touch electrical parts or jet pump area when engine is running.

▼ **CAUTION** : Engine should always be started with the watercraft in water. At least 60 cm (2 ft) of water should be present below the hull.

◆ **WARNING** : Since the engine is directly coupled to the jet pump, the watercraft moves forward even when the throttle is closed.

Attach the tether cord to the operator's lifejacket and snap the cap to the switch before starting the engine.

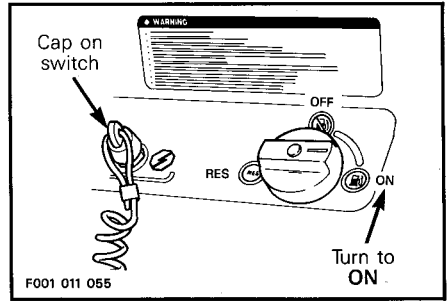
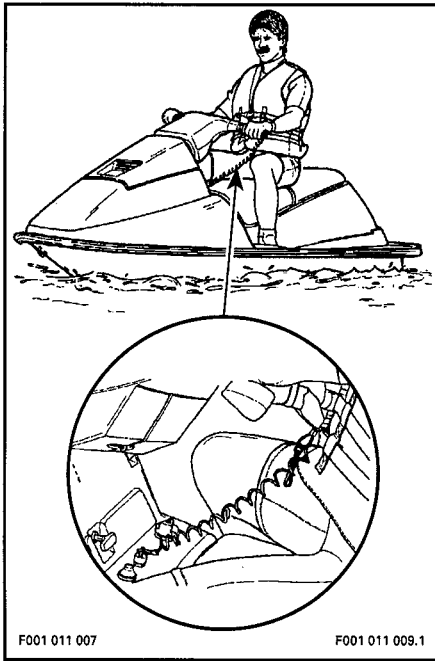

Fully pull the choke knob.

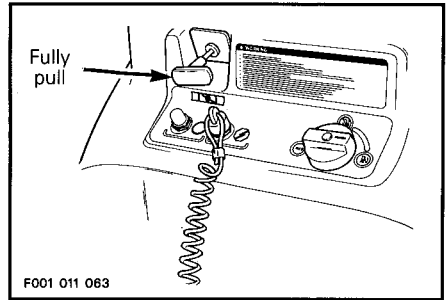

Firmly grip handlebar and place both feet on the floorboard. Depress the starting button.

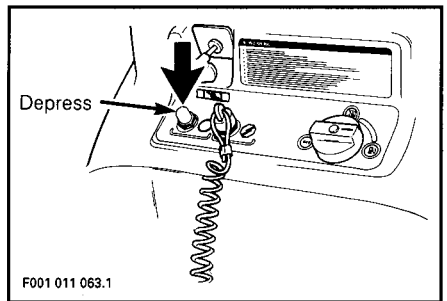

Cold Engine

Operator and passenger should be sitting on the watercraft seat prior to starting the engine.

Turn the fuel valve to ON.

○ **NOTE** : Do not depress the throttle lever while starting a cold engine.

▼ **CAUTION** : To avoid starter motor overheating, the cranking period should not exceed 5-10 seconds and a rest period should be

observed between cranking cycles to let the starter cool down and its mechanism disengage. Never depress the starting button when the engine is running.

Immediately after engine is started, release starting button and release choke knob half way.

A few seconds after, completely push the choke knob and if necessary, slightly apply throttle to keep engine running. Do not apply full throttle until the engine is warm.

Slowly accelerate to reach deeper water.

CAUTION : Do not accelerate fast when the watercraft is in shallow water. Shells, sand, pebbles or other objects could be drawn up by the jet pump and damage impeller, components or clog or jam the cooling system.

Warm Engine

The same procedure as a cold engine applies, except the choke does not need to be applied and throttle lever has to be slightly depressed.

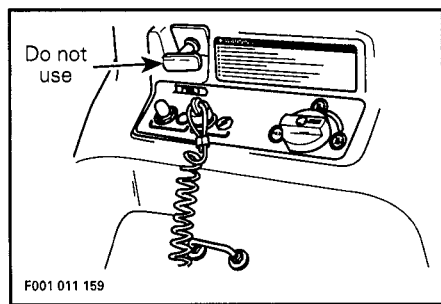

Boarding in Deep Water

WARNING : An inexperienced operator should practice how to get aboard close to shore first before venturing into deep water.

Operator Alone

Swim to the rear of the watercraft.

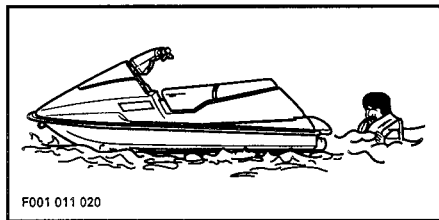

Grip the grab handle (if applicable) and pull yourself upward until your knee can reach the boarding platform then grip the seat strap.

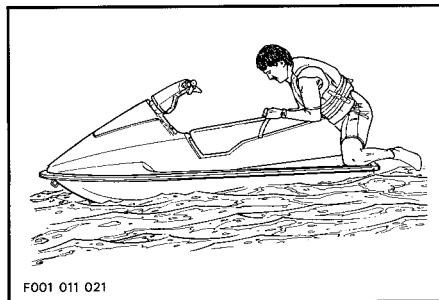

Bring your feet on the floorboard while maintaining balance using the handlebar.

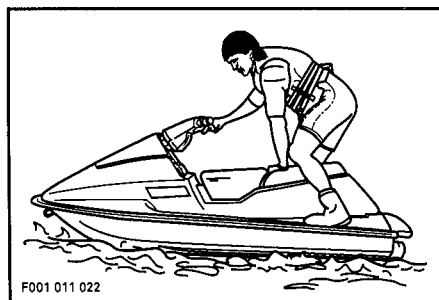

Sit astride the seat.

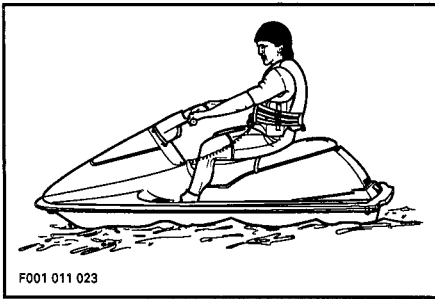

Attach the tether cord to the operator's lifejacket and snap the cap to the switch before starting the engine.

Start the engine.

Operator with Passenger

The operator climbs on the watercraft the same way as explained previously.

In choppy water, the passenger while in the water, may maintain the watercraft's balance to help the operator in climbing aboard.

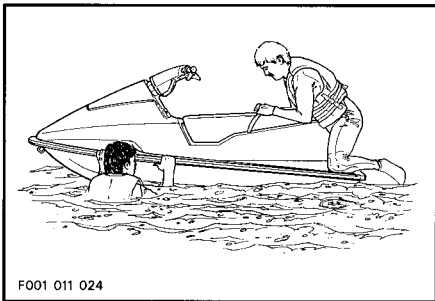

The passenger then climbs on the watercraft while the operator maintains balance by sitting as close as possible to the console.

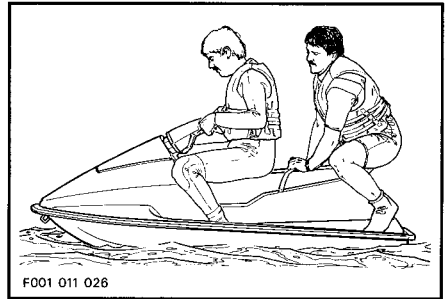
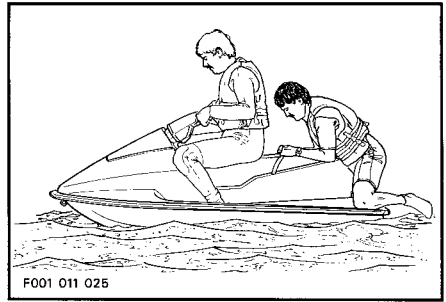

▼ **CAUTION :** If vent grill is kept below water level for a long period water will enter the bilge and possibly the engine.

Attach the tether cord cap to the switch before starting the engine.

◆ **WARNING :** Do not start engine until the passenger is properly seated.

Rough Water Operation

Avoid riding in rough water and / or adverse weather conditions.

◆ **WARNING :** Riding the watercraft in these conditions could cause loss of control, injury or death to the operator and / or passenger.

Always assist the rider(s) of a capsized boat then attempt to retrieve vessel using a tow rope.

It is not recommended to operate the watercraft within or around the surf-line.

If the watercraft is operated on rough water, the engine may make a misfiring sound. This is caused by a speed limiter which is intended to prevent the unloaded engine from exceeding a predefined RPM.

◆ **WARNING :** Wave jumping is a dangerous and may be illegal practice. Do not jump waves or boat wakes. Jumping waves can overstress the watercraft hull causing it to crack and result in personal injury.

Crossing Waves

Reduce speed and cross the wave head on to assist steering.

Always be prepared to steer and balance as necessary.

◆ **WARNING :** When crossing waves operator and passenger should brace themselves by crouching.

Docking

The watercraft is slowed by water drag. The stopping distance will vary depending on the watercraft mass, carrying weight, water surface condition, presence and direction of wind and current.

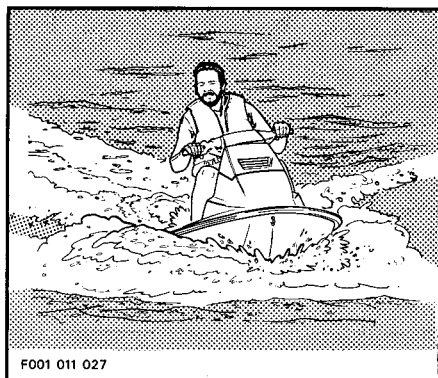

The operator should experiment to familiarize himself with the stopping distance under different conditions.

Do not go close to crafts, swimmers, underwater near-surface obstacles, etc.

Release the throttle a sufficient distance before the expected landing area, the water resistance slows down the watercraft. Remember no directional control is available when throttle is released.

Reduce speed when approaching a dock then shut off the engine just before coming alongside.

◆ **WARNING :** No directional control is available when the throttle is closed or engine is shut off.

Beaching

▼ **CAUTION** : It is not recommended to run the watercraft to the beach.

Proceed the same way as for docking except for the following :

Come slowly to the beach and shut off the engine when reaching about 60 cm (2 ft) of water under the hull.

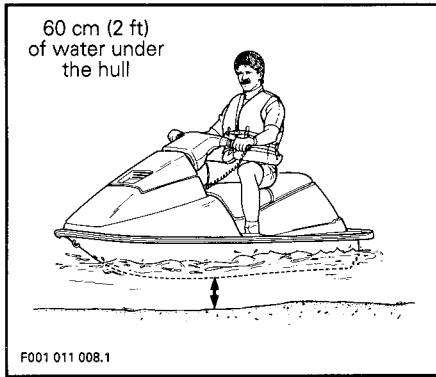

▼ **CAUTION** : The engine must be shut off before less than 60 cm (2 ft) of water is underneath the hull. Shells, sand, pebbles or other objects could be drawn up by the jet pump and damage impeller, components or clog or jam cooling system.

Get off watercraft and pull it on the beach.

As necessary, cooling system should be flushed before restarting, to remove sand or shell accumulation which may clog the water passages.

Shutting Off the Engine

To keep watercraft directional control, the engine should be running until the watercraft is stopped assuming at least 60 cm (2 ft) of water is present underneath the hull.

To shut off the engine, completely release throttle lever and press the engine stop button.

◆ **WARNING** : Should the engine be shut off, watercraft directional control is not available.

Remove tether cord from watercraft.

◆ **WARNING** : Never leave the tether cord on an unattended watercraft.

POST-OPERATION CARE

General Care

Should any water be present in the hull, remove the drain plug and tilt the watercraft to the rear in order to allow water to flow out.

Wipe up any remaining liquid in the engine compartment (bilge, engine, battery, etc.) with clean dry rags (this is particularly important in salt water use).

Remove the watercraft from the water every day to prevent marine organisms growth.

Leave the seat partially opened. This will avoid engine compartment condensation and possible corrosion.

○ **NOTE :** When the watercraft is stored with seat partially opened and without a tarpaulin, remove the drain plug in order to avoid water build up in the bilge during rainfall.

Additional Care for Unclean Water or Salt Water

When the watercraft is operated in unclean water and particularly in salt water, additional care must be taken to protect, the watercraft and its components. Rinse bilge area with fresh water.

▼ **CAUTION :** Failure to perform proper care such as : watercraft rinsing, cooling system flushing and anticorrosion treatment, when watercraft is used in salt water, will result in damage to the watercraft and its components.

▼ **CAUTION :** Never leave the watercraft stored in direct sunlight. UV radiation will dull finishes.

Cooling System Flushing and Engine Internal Lubrication

When the watercraft is operated in unclean water and particularly in salt water, flushing of cooling system and engine lubrication are necessary.

Flushing and lubrication will be done at the same time while engine is running.

▼ **CAUTION :** Failure to perform cooling system flushing, when watercraft is used in salt water, will result in damage to watercraft components.

Since the watercraft uses the same water where it sails, for propulsion and cooling systems, this water flows everywhere in water jackets. If the watercraft is being used in salt water and cooling system is not regularly flushed, salt will corrode components.

Infiltration in cooling system of any particle present in the water is unavoidable. Deposit accumulation can clog cooling system and lead engine to severe damage.

Flushing is necessary when the watercraft is operated in :

- salt water
- unclean water
- shallow water where underwater ground is sandy and / or shell covered

Flushing the cooling system **with fresh water** is essential to neutralize corroding effects of salt or other chemical products present in water. It will help to clean up sand, salt, shells or other particles in water jackets (engine, exhaust manifold, tuned pipe) and / or hoses.

Engine lubrication and flushing should be performed when the watercraft is not expected to be used further the same day or when the watercraft is stored for any extended time.

CAUTION : Failure to flush cooling system, when necessary, will severely damage engine and / or exhaust system. Never flush a hot engine. Make sure engine operates during entire procedure.

A convenient coupler hose (P / N 295 500 099) can be installed on the watercraft to ease flushing.

Proceed as follows :

WARNING : Perform this operation in a well ventilated area.

1. Clean jet pump by spraying water in its inlet and outlet and then SEA-DOO LUBE.

WARNING : Always remove tether cord cap from switch to prevent accidental engine starting before cleaning the jet pump area. Engine must not be running for this operation.

2. Remove seat to allow access of cooling system.

3. Remove dust cap from tee fitting spigot and attach coupler hose. Make sure coupler hose is properly locked to tee fitting spigot.

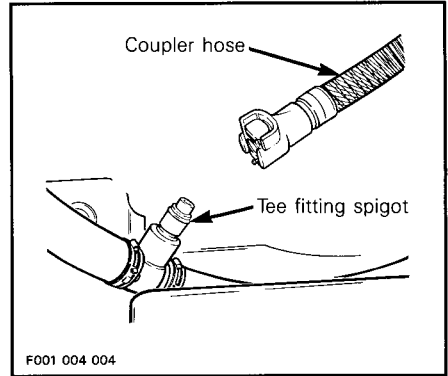

Attach other end of coupler hose to a garden hose. **Do not open water tap yet.**

NOTE : To allow a more efficient flushing on watercraft, install a hose pincher (P / N 295 000 076) between tee fitting and exhaust socket. This prevents water from exiting through exhaust socket. Remove hose pincher after flushing operation.

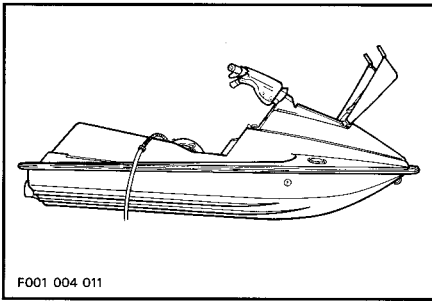

4. Start the engine then immediately open the water tap.

◆ **WARNING** : Do not touch any electrical part or jet pump area when engine is running.

▼ **CAUTION** : Never flush a hot engine. Always start the engine before opening the water tap. Otherwise, water will back flow through the tuned pipe into the engine and may cause damage to internal parts. Open water tap immediately after engine is started to prevent overheating. Follow this procedure exactly.

5. Run the engine about five minutes at a fast idle around 3500 RPM.

▼ **CAUTION** : Never run engine longer than five minutes. Drive line seal has no cooling when watercraft is out of water.

6. Remove plug from flame arrester cover.

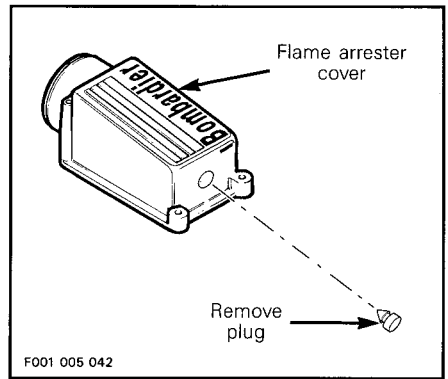

7. Spray some SEA-DOO LUBE (P / N 293 600 006) through flame arrester cover keeping engine at fast idle.

▼ **CAUTION** : Do not use outboard type storage lubricant. Using outboard lubricant may accelerate corrosion and damage engine components.

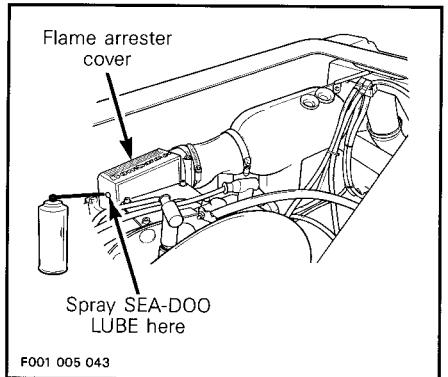

Lubrication of engine should be done at least for one minute. After approximately half a minute, close fuel tank valve to run engine out of fuel while lubricating.

▼ **CAUTION :** When engine begins to run irregularly because of fuel starvation, immediately stop water flow before engine dies. Severe engine damage could result if not done in this order.

8. Close the water tap then stop the engine.

▼ **CAUTION :** Always close the water tap before stopping the engine. Follow this procedure exactly otherwise severe engine damage could occur.

9. Press unlocking button to remove coupler hose. Reinstall dust cap over tee fitting.

10. Wipe up any residual water on the engine.

11. Remove spark plug cables and connect them on the grounding device.

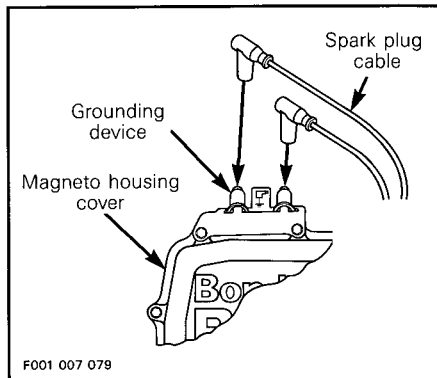

Remove both spark plugs and spray some SEA-DOO LUBE into each cylinder.

Crank the engine a few turns to distribute the oil on cylinder wall.

12. Apply anti-seize lubricant on spark plug threads then reinstall them.

13. Reinstall plug on flame arrester cover.

▼ **CAUTION :** Do not run the engine during the storage period.

Anticorrosion Treatment

To prevent corrosion, spray a corrosion inhibitor (salt water resistant) such as SEA-DOO LUBE (P / N 293 600 006) or the equivalent over all metallic components in engine compartment.

○ **NOTE :** Engine fogging should be done with SEA-DOO LUBE whenever the watercraft is to be stored for few days or a long period.

Apply a dielectric grease (P / N 293 550 004) or similar anticorrosion product (salt water resistant) on battery posts and cable connectors.

▼ **CAUTION :** Never leave rags or tools in the engine compartment or in the bilge.

SPECIAL PROCEDURES

Engine Overheat

If the engine overheating beeper sounds, stop engine immediately.

Perform the Jet Pump Water Intake and Impeller Cleaning procedure.

Flush cooling system, refer to POST OPERATION CARE.

If engine still overheats, refer to an authorized dealer for servicing.

Jet Pump Water Intake and Impeller Cleaning

Weeds, shells or debris can get caught on the intake grill, drive shaft and / or impeller. A clogged water intake may cause troubles such as :

- 1- **Cavitation** : Engine speed is high but watercraft moves slowly due to reduced jet thrust, jet pump components can be damaged.
- 2- **Overheating** : Since the jet pump operation controls the flow of water to cool the engine, a clogged intake will cause the engine to overheat and damage engine internal components.

The clogged area can be cleaned as follows :

In-water cleaning : Rock the watercraft several times while repeatedly pressing starter button for short period without starting engine. Most of the time, it gives satisfactory result letting the weeds fall from the intake area. Start engine and make sure water flows out from bleed outlets and watercraft operates properly.

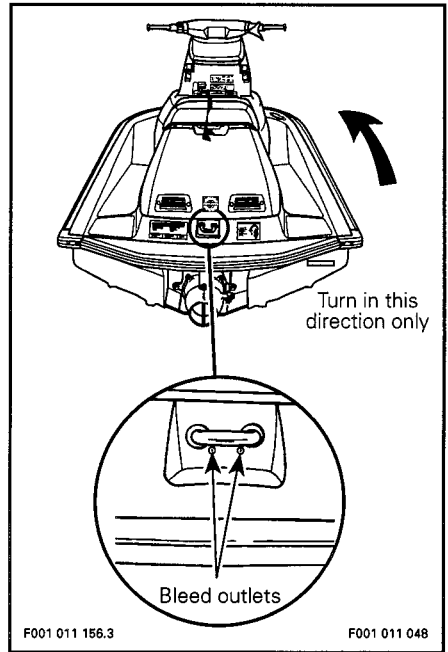

On-beach cleaning : Place a cardboard or a carpet beside the watercraft to prevent scratching when turning the watercraft for cleaning.

◆ **WARNING** : Always remove tether cord cap from switch to prevent accidental engine starting before cleaning the jet pump area. Engine must not be running for this operation.

Rotate the watercraft counterclockwise (seen from rear) to its left side for cleaning. Rotating watercraft counterclockwise eliminate the possibility of residual water in the tuned pipe to enter the engine and cause engine damage.

▼ **CAUTION** : Always turn the watercraft counterclockwise (seen from rear). Otherwise cooling water could leak through the tuned pipe into the engine and cause engine damage.

Capsized Watercraft

The watercraft is designed so that if it is turned over, it should not remain capsized due to its self-righting capability.

▼ **CAUTION** : In the event engine is water-flooded, it must have proper treatment to prevent damage to engine internal parts. Refer to an authorized dealer immediately.

Submerged Watercraft

If the watercraft is submerged and engine is water-flooded, it is strongly recommended that the watercraft be serviced by an authorized dealer immediately.

In the event the engine cannot be serviced within a few hours. Remove engine crankcase drain plugs located underneath oil injection pump.

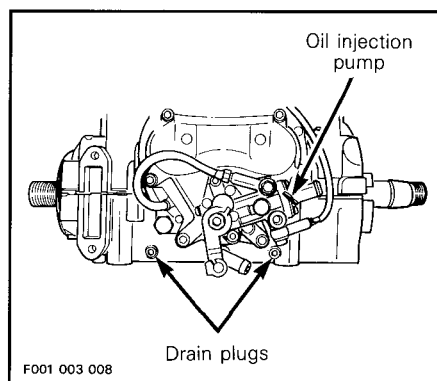

Remove spark plug cables and connect them on the grounding device.

◆ **WARNING** : Never crank engine with spark plugs removed unless spark plug cables are connected to the grounding device.

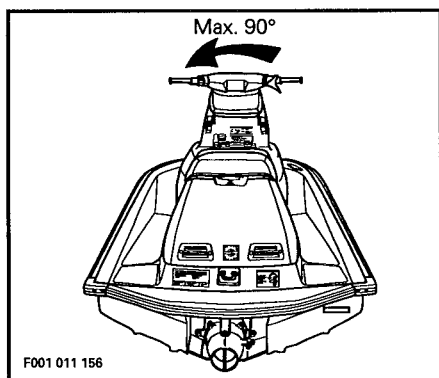

Clean the water intake area. If the system is still clogged, refer to an authorized dealer for servicing.

▼ **CAUTION** : Inspect water intake grill for damage. Refer to an authorized dealer for repair as necessary.

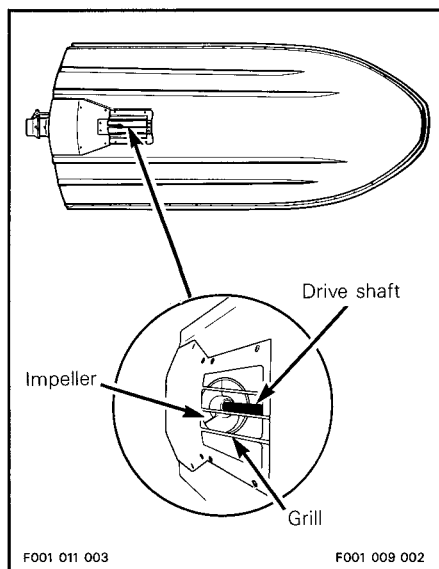

▼ **CAUTION** : Avoid watercraft operation in weed areas. If unavoidable, vary watercraft speed. Weeds tend to entangle more at steady speed and at slow speed.

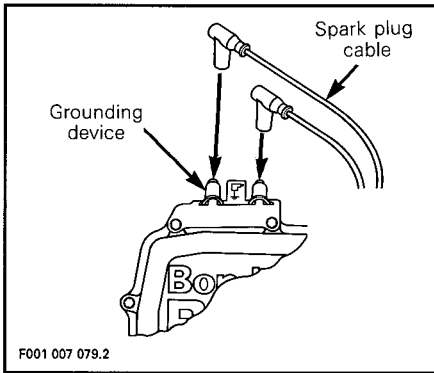

Towing the Watercraft

In the event the watercraft becomes inoperative, tie a tow rope to the bow (front) eyelet and have the watercraft towed to the shore at moderate speed.

Low-Charge Battery Condition

◆ **WARNING:** Do not boost the battery. Do not charge the battery in the watercraft. Connecting cables could produce a spark into the engine compartment and possibly cause an explosion if fuel or electrolyte vapors are present.

Following the recommended procedure in the MAINTENANCE section, remove the battery. Have it charged or replaced.

Remove spark plugs and dry them with a clean and dry cloth.

Cover spark plug holes with a rag.

Crank engine to allow water to escape from spark plug and drain plug holes.

Spray SEA-DOO LUBE (P / N 293 600 006) into spark plug holes.

Crank engine again.

Reinstall spark plugs and drain plugs.

▼ **CAUTION:** Crankcase drain plugs should have Loctite PST 567 (P / N 293 800 013) applied to threads before installing.

MAINTENANCE

◆ **WARNING :** Only perform procedures as detailed in this guide. It is recommended that the assistance of an authorized dealer be periodically obtained on other components / systems not covered in this guide. Unless otherwise specified, engine must not be running and the tether cord must be removed for all maintenance procedures.

○ **NOTE :** Servicing period is given in hours. On an average, three hours is equivalent to using one tank of gasoline.

Lubrication

PTO Flywheel and Seal Carrier Grease Fittings

Use SEA-DOO synthetic grease (P / N 293 550 010) and lubricate every 10 hours. Proceed as follows :

Remove seat to expose engine compartment.

◆ **WARNING :** Always remove tether cord cap from its receptacle to prevent accidental engine starting before removing the PTO flywheel guard.

Remove the wing nuts, washers and pull PTO flywheel guard.

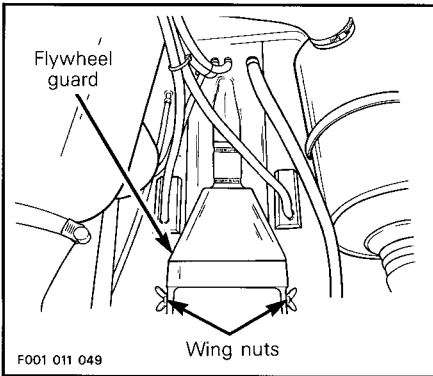

Using a grease gun, carefully lubricate at grease fitting until drive shaft boot is just beginning to expand.

▼ **CAUTION :** Immediately stop lubricating as soon as boot begins to expand to prevent boot damage or slipping.

Lubricate at seal carrier grease fitting until grease is just coming out on engine side.

▼ **CAUTION :** Never leave any clothing, tool or other objects near PTO flywheel and seal carrier. As soon as grease comes out the seal immediately stop lubricating to prevent seal damage and overheating.

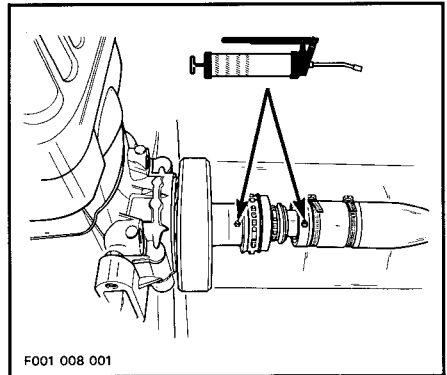

Secure PTO flywheel guard.

Anticorrosion Protection

Throttle / Choke Cables

Lubricate the throttle and choke cables with SEA-DOO LUBE (P / N 293 600 006) every 25 hours and every 10 hours in salt water use.

 **NOTE :** A cable luber can be used on cable end to inject SEA-DOO LUBE. Refer to a motorcycle parts supplier for availability.

Electrical Connections

As necessary, apply anticorrosion product such as a dielectric grease (P / N 293 550 004) on battery posts and all exposed cable connectors.

Additional Lubrication

SEA-DOO LUBE will help to prevent corrosion and keep proper operation of moving mechanisms.

Lubrication of the following items should be performed every 50 hours in fresh water use but every 10 hours in salt water use.

Choke Knob Lever

Fully pull choke knob and lubricate the metallic portion.

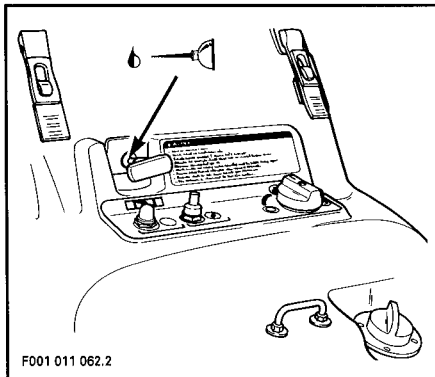

Seat Opening Mechanism, Tab, Hooks and Lock Pin

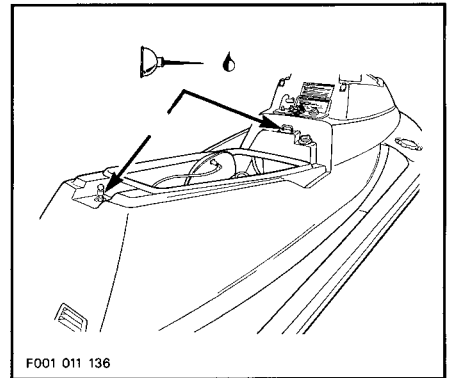
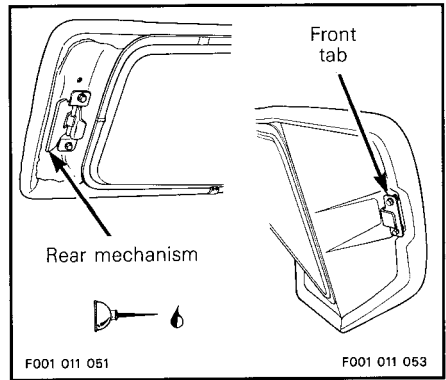

Carburetors and Oil Injection Pump

Lubricate springs, shafts and exposed portion of cables.

○ **NOTE** : Grease carburetors linkage at both ends with synthetic grease (P / N 293 550 010), if applicable

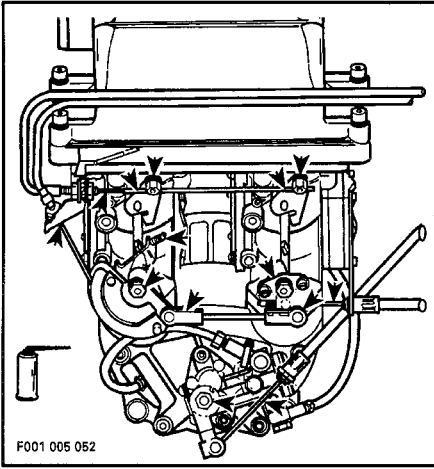

Periodic Inspection

Routine maintenance is necessary for all mechanized products, and this watercraft is no exception. A periodic inspection contributes to the life span of the watercraft.

The following maintenance chart gives guidelines for regular servicing schedule to be performed by you or by an authorized dealer. The schedule can be adjusted according to operating conditions and use.

IMPORTANT : Schedule for watercraft rental operations or higher number of hour use, will require greater frequency of inspection and maintenance.

Periodic Inspection Chart

| DESCRIPTION | FREQUENCY | | | | |
|---------------------------------------------------------------------------------------------------------------------|-----------|----------|----------|-----------|--------------------|
| | 10 Hours | 25 Hours | 50 Hours | 100 Hours | To be performed by |
| Lubrication / corrosion protection | ① | | ✓ | | OPERATOR |
| Engine ignition timing | | | | ✓ | DEALER |
| Spark plugs, cleaning / adjustment | | ✓ | | | OPERATOR |
| Throttle / choke cables, inspection / lubrication | ① | ✓ | | | OPERATOR |
| Flame arrester element, inspection | | | ✓ | | DEALER |
| Carburetor adjustment including choke / throttle cable adjustments and linkage | | | | ✓ | DEALER |
| Oil injection pump adjustment | | | | ✓ | DEALER |
| Fuel filter and oil filter inspection | ✓ | | | | OPERATOR |
| Oil filter and fuel filter replacement | | | | ✓ | DEALER |
| Engine head screws, retorque | | | | ✓ | DEALER |
| Steering column wear / steering cable adjustment | | | | ✓ | DEALER |
| Fastener tightening (Flame arrester mount screws, carburetor mount nuts, engine mount screws, exhaust system, etc.) | | | ✓ | | DEALER |
| Muffler, battery and reservoir fastening devices | | | ✓ | | OPERATOR |
| Fuel / oil lines, check-valves and hoses inspection, fuel system pressurization | | | ✓ | | DEALER |
| Inspect / clean engine drain tube | ① | ✓ | | | DEALER |
| Bilge system / water tank trap drain , inspection | | | ✓ | | OPERATOR |
| Battery condition | | | ✓ | | DEALER |
| Battery and starter cables | | ✓ | | | DEALER |
| Engine overheating beeper / electrical connections | | | ✓ | | DEALER |
| Impeller shaft reservoir oil level / oil condition | | ✓ | | Replace | DEALER |
| Impeller condition and impeller / wear ring clearance | | ② | ✓ | | DEALER |
| Drive shaft boot and splines condition (both ends) | | ② | ✓ | | DEALER |
| Drive shaft, lubricate grease fitting at PTO flywheel | ✓ | | | | OPERATOR |
| Seal carrier, lubricate grease fitting | ✓ | | | | OPERATOR |
| Water intake grill condition | | ② | ✓ | | DEALER |
| Hull condition | | | | ✓ | DEALER |
| Cooling system flushing ③ | | ✓ | | | OPERATOR |

○ **NOTE :** Some items are included in the DAILY PRE-OPERATION CHECKS and are not necessarily repeated in this chart.

- ① Every 10 hours in salt water use.
- ② These items have to be initially checked after 25 hours. Thereafter, servicing to be made as specified in this chart.
- ③ Daily flushing in salt water or unclean water use.

Spark Plug Cleaning and Adjustment

Spark plugs indicate the general engine condition and are easy to inspect. The tip condition of each spark plug should be checked for wear, cracks in porcelain, carbon or other deposits and color. A worn spark plug should be replaced by a new one. Abnormal deposits or tip color should be diagnosed by an authorized dealer.

◆ **WARNING :** Never crank engine with spark plugs removed unless spark plug cables are connected to the grounding device.

Remove spark plugs and check condition.

The following gives guidelines about spark plug tip color :

- A brownish tip reflects ideal conditions.
 - Correct carburetor adjustments, spark plug heat range, etc.
- A black insulator tip indicates fouling, possibly caused by :
 - Carburetors idle speed mixture and / or high speed mixture too rich.
 - Incorrect oil pump adjustment (too rich).
 - Wrong spark plug type and / or heat range.
 - Excessive idling.
 - RPM limiter malfunction.
- A light grey insulator tip indicates a lean mixture, possibly caused by :
 - Carburetor high speed mixture too lean.
 - Wrong spark plug heat range.
 - Incorrect oil pump adjustment (too lean).
 - Leaking engine seal or gasket.

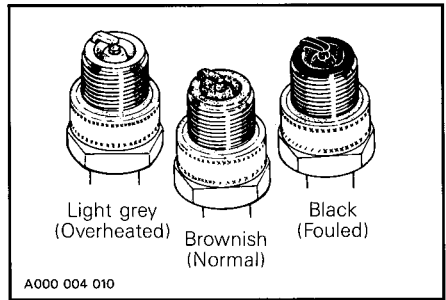

▼ **CAUTION :** If spark plug condition is not ideal, contact an authorized dealer.

Spark plug type is : NGK BR7ES (P / N 278 000 140).

Clean spark plug and adjust gap to 0.5-0.6 mm (.020 - .024 in) using a feeler gauge.

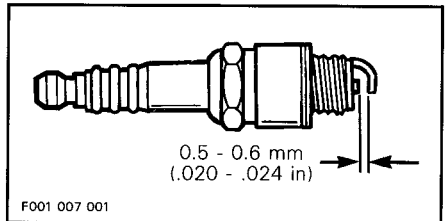

Reinstall spark plugs, properly tighten then reconnect cables.

▼ **CAUTION :** When installing or removing spark plugs be careful not to damage the porcelain insulator.

Throttle and Choke Cable Inspection

Throttle Cable

Depress and release the throttle lever several times. It must operate smoothly and return to its initial position without any hesitation. Refer to an authorized dealer if necessary.

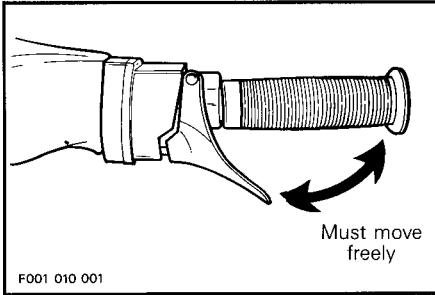

Verification of Oil Injection Pump Alignment Marks

Eliminate the throttle free-play by pressing the throttle lever until a slight resistance is felt then hold in place. The alignment marks on the pump body and lever must perfectly align. If not, do not attempt to adjust, contact an authorized dealer for adjustment. Any delay in the opening of the pump can result in serious engine damage.

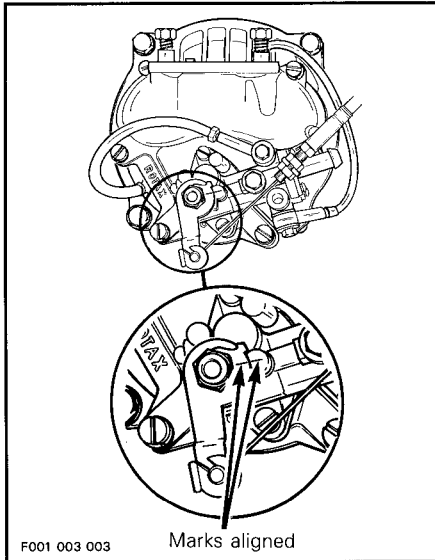

Choke Cable Inspection

Ensure it operates smoothly and without any hesitation from fully open to fully close. When the choke knob is fully pulled, choke must be fully applied. Refer to an authorized dealer if necessary.

Carburetor Adjustment

Carburetor adjustment is very important to allow good engine operation and therefore watercraft performance. Carburetor adjustment require technical knowledge and experience to have the correct mixture supplied to the engine. These critical adjustments must be performed by an authorized dealer once a year or more often if necessary.

▼ **CAUTION** : Serious engine damage can occur with improper carburetor adjustments.

Fuel and Oil Filters

These filters should be replaced by an authorized dealer annually. Fuel system pressurization should be conducted at the same time.

Oil Filter Inspection

The in-line oil filter is located close to the engine.

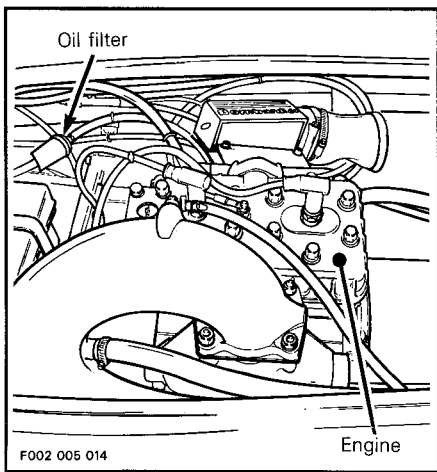

Vacuum Bailer Pick-Ups and Water Tank Trap Drains

Vacuum Bailer Pick-Ups

They are located each side of the drive shaft tunnel.

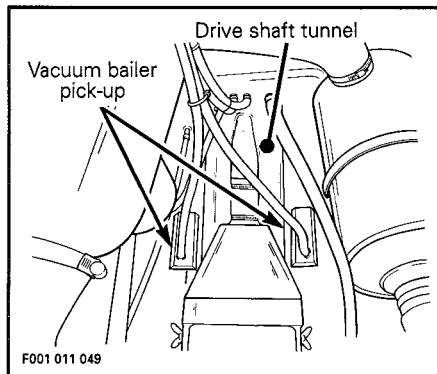

Visually inspect the oil filter at least every 10 hours. Ensure that it is free of water, clean and no foreign particles are present, if so, refer to an authorized dealer for replacement.

▼ **CAUTION:** An obstructed injection oil filter will cause oil starvation resulting in serious engine damage.

Steering / Jet Pump Nozzle Adjustment

When the handlebar is aimed in straight ahead position, the jet pump nozzle should be in the same direction to allow the watercraft running in straight line.

Refer to an authorized dealer if an adjustment is necessary.

◆ **WARNING:** Ensure the handle bar / jet pump nozzle operate freely from side to side and are not stressing the steering cable and / or bracket.

Steering column wear should be inspected every 100 hours by an authorized dealer.

This watercraft features a vacuum activated syphon. Two bailer pick-ups use a low pressure area in the jet pump to syphon the water out of the bilge.

Inspect each pick-up screen for obstructions, clean as necessary.

Water Tank Trap Drains

Check for possible obstructions at drain outlets each side of the hull at the front.

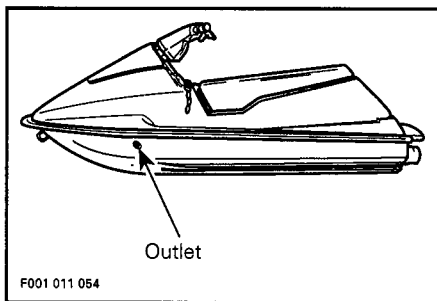

Fuse Cap

Electrical system is protected with two fuses. One fuse protects the charging circuit, the second fuse protects the accessories and controls. If starter does not operate and battery is regularly discharged, check fuse condition. The fuse caps are in the electrical box located on port side (left) and hold spare fuses.

To access fuse caps unclip electrical box from its seat.

Bring it outside watercraft and remove cover.

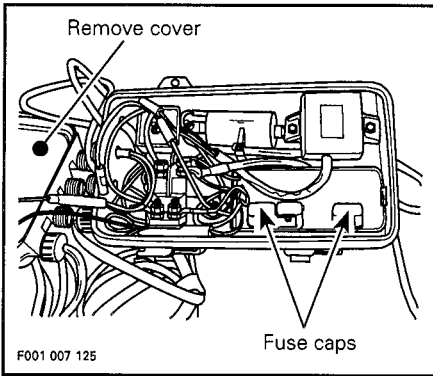

Replace the fuse by one of the same rating. Make sure to properly close the fuse cap.

CAUTION : Do not use a higher rated fuse as this can cause severe damage.

NOTE : Refer to SPECIFICATIONS section for recommended fuse rating.

Wires in electrical box cover must hang freely. Do not pack wires in cover.

WARNING : If any water is found in the electrical box, immediately refer to an authorized dealer before operating the watercraft.

Properly close electrical box cover making sure its seal is well positioned.

Battery

WARNING : For any battery maintenance, the battery must be removed from the watercraft.

Battery Removal

Proceed as follows :

1. Disconnect the **black** negative cable first.

WARNING : Always disconnect battery cables exactly in the specified order, black negative cable first. Electrolyte or fuel vapors can be present in the engine compartment and a spark might ignite them and possibly cause personal injuries.

2. Then disconnect the red cable last.

3. Remove the vent tube from the battery.

4. Remove the holding straps,

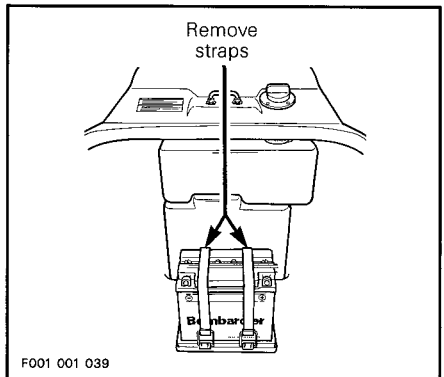

5. Remove battery from the watercraft being carefull not to tilt it so that electrolyte cannot flow out of vent fitting.

▼ **CAUTION** : Should any electrolyte spillage occur, immediately wash off with a solution of baking soda and water to prevent damage to watercraft components.

◆ **WARNING** : Electrolyte is poisonous, dangerous and explosive. It contains sulfuric acid and can cause severe burns. Avoid contact with eyes, skin and clothing. Read and observe battery instructions found in other sections of this guide.

Battery Maintenance

◆ **WARNING** : Battery must be kept in good condition. Without battery, the watercraft can not be started. Inspect battery electrolyte level regularly. Have its condition checked by an authorized dealer every 25 hours of operation.

Check electrolyte level when performing the DAILY PRE-OPERATION CHECKS. It should be maintained at the HIGHER level line of the battery casing.

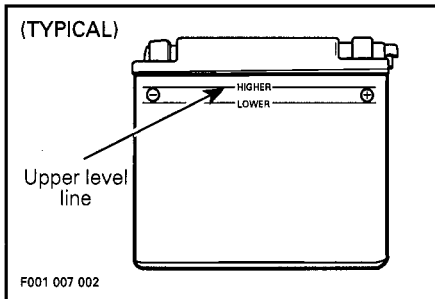

Add distilled water as necessary.

Battery posts and connections must be free of corrosion. If cleaning is necessary, remove corrosion with a stiff wire brush then clean with a solution of baking soda and water. Rinse with clear tap water and dry well.

▼ **CAUTION** : Do not allow cleaning solution to enter the battery. It will destroy the chemical properties of the electrolyte.

Fully charge the battery at a maximum rate of two amperes.

Contact your authorized dealer or refer to the appropriate *Shop manual* for charging procedure.

◆ **WARNING** : Gases given off by a battery being charged are highly explosive. Always charge in a well ventilated area. Keep battery away from sparks, cigarettes or open flames. Avoid skin contact with electrolyte.

○ **NOTE** : If the battery is not to be used for a month or more, refer to STORAGE section for proper maintenance.

Battery Installation

◆ **WARNING** : Always connect battery cables exactly in the specified order, red positive cable first black negative cable last.

Proceed as follows :

1. Install battery in its emplacement.
2. Secure vent tube to the battery. Ensure vent tube is not kinked or obstructed.

▼ **CAUTION** : Battery vent tube must be free, open and securely installed. If not, it will restrict ventilation and create gas accumulation that could result in an explosion. Avoid skin contact with electrolyte.

3. First connect red positive cable.
4. Then connect black negative cable last.
5. Apply anticorrosion product (salt water resistant) such as dielectric grease (P/N 293 550 004) or the equivalent on battery posts.
6. Verify cable routing and attachment.

General Inspection and Care

Inspection

Check engine compartment for any damage and fuel / oil injection systems for leaks. Also check battery vent tube for electrolyte leaks. Ensure all hose clamps are properly secured and no hose is cracked, kinked or presenting any other damage.

◆ **WARNING** : If any leak is found, do not start the engine. Have the watercraft serviced by an authorized dealer. Failure to correct a leak could lead to an explosion.

Inspect muffler, battery and reservoir fastening devices. Check electrical connections for corrosion and tightness.

Inspect hull, jet pump water intake grill for damage. Replace or have damaged parts repaired. It is recommended that an authorized dealer annually inspect the hull condition.

Care

Twice a year, the bilge should be cleaned with hot water and detergent or bilge cleaner to remove any possible fuel / oil / electrolyte deposits.

Occasionally, wash the body with hot water and soap (only use mild detergent). Remove any marine organisms from engine and / or hull. Apply non-abrasive wax such as silicon wax.

▼ **CAUTION** : Never clean apparent fiberglass and plastic parts with strong detergent, degreasing agent, paint thinner, acetone, etc.

TRANSPORTATION, STORAGE AND PRE-SEASON PREPARATION

◆ **WARNING:** Always turn the fuel valve to OFF when transporting or storing the watercraft.

Transportation

Tie the watercraft to both bow and stern (front / rear) eyelets so that it is firmly retained on the trailer. Use additional cables if necessary.

▼ **CAUTION:** Do not route ropes or tie-downs over the seat as they could produce permanent damage. Wrap ropes or tie-downs with rags or similar protectors where they can touch the watercraft body.

Ensure seat and storage cover are properly latched.

A SEA-DOO cover should protect the watercraft, particularly before driving on dirt roads, to prevent dirt entry through the air intake opening and clogging the water tank trap drains.

Observe trailering safety precautions.

Storage

It is during winter or when the watercraft is not to be in use for prolonged time that a proper storage is a necessity. Storage during long period of inactivity consists of checking and replacing missing, broken or worn parts and protecting cooling system against freezing and corrosion.

Proper lubrication and treatment should be performed to insure that parts do not become corroded and in general, preparing the watercraft so that when the time comes to use it again, it will be in top condition.

It is recommended that the watercraft be serviced by an authorized dealer for storage but the following operations can be performed by you with a minimum of tools.

Engine Draining

Check engine drain tube running from engine water inlet socket to exhaust outlet socket. Make sure there is no sand or other particles in it and that it is not obstructed so that water can leave the engine. Clean tube and fitting (on exhaust outlet) as necessary.

▼ **CAUTION:** Water in engine drain tube must be free to flow out, otherwise water could be trapped in engine. Should water freeze in engine, severe damage will occur. Check engine drain tube for obstructions.

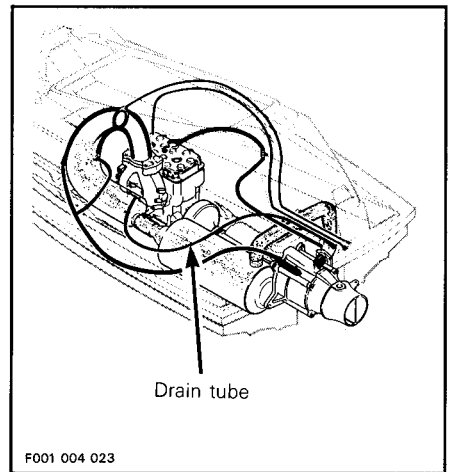

Watercraft Rinsing

Thoroughly rinse the watercraft hull, bilge, engine compartment, with fresh water.

Propulsion System

Lubricant in impeller shaft reservoir should be drained and reservoir cleaned refilled with 65 mL (2.2 U.S. oz) of SEA-DOO synthetic oil polyolester (P / N 293 600 011) 75W 90 GL5 type C gear lube. Refer to an authorized dealer for this operation.

▼ **CAUTION :** Use only SEA-DOO jet pump oil or equivalent synthetic gear oil, otherwise component service life could be reduced. Do not mix oil brands or types.

Lubricate drive shaft splines through grease fitting at PTO flywheel end with synthetic grease (P / N 293 550 010).

▼ **CAUTION :** Do not lubricate excessively. Immediately stop when a slight movement is noticed on rubber boot.

Lubricate at seal carrier grease fitting until grease is just coming out on engine side.

▼ **CAUTION :** As soon as grease comes out the seal immediately stop lubricating to prevent seal damage and overheating.

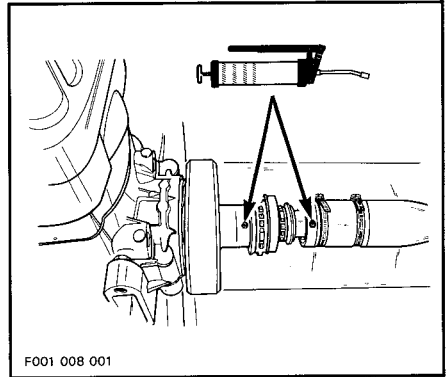

Fuel System

A fuel stabilizer, such as Sta-Bil® (or equivalent), can be added in fuel tank to prevent fuel deterioration and carburetor(s) gumming. Follow manufacturer's instructions for proper use.

▼ **CAUTION :** Fuel stabilizer should be added prior engine lubrication to ensure carburetor(s) protection against varnish deposit.

◆ **WARNING :** Fuel is flammable and explosive under certain conditions. Always work in a well ventilated area. Do not smoke or allow open flames or sparks in the vicinity. Always wipe off any fuel spillage from the watercraft.

Cooling System Flushing and Engine Internal Lubrication

Cooling system has to be flushed with **fresh water** to prevent salt, sand or dirt accumulation which might clog water passages. This will be achieved with the coupler hose (P / N 295 500 099).

Engine must be lubricated to prevent corrosion on internal parts. This will be achieved by spraying SEA-DOO LUBE (P / N 293 600 006) through air intake opening.

CAUTION : Do not use out-board type storage lubricant. Using outboard lubricant may accelerate corrosion and damage engine components.

Procedure

WARNING : Perform this operation in a well ventilated area.

1. Clean jet pump by spraying water in its inlet and outlet and then SEA-DOO LUBE.

WARNING : Always remove tether cord cap from switch to prevent accidental engine starting before cleaning the jet pump area. Engine must not be running for this operation.

2. Remove seat to allow access of cooling system.

3. Remove dust cap from tee fitting spigot and attach coupler hose. Make sure coupler hose is properly locked to tee fitting spigot.

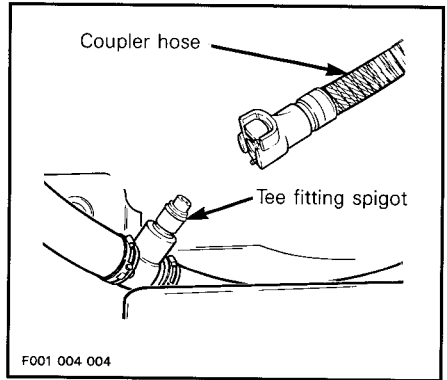

Attach other end of coupler hose to a garden hose. **Do not open water tap yet.**

NOTE : To allow a more efficient flushing on watercraft, install a hose pincher (P / N 295 000 076) between tee fitting and exhaust socket. This prevents water from exiting through exhaust socket. Remove hose pincher after flushing operation.

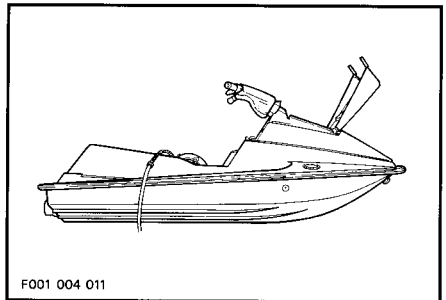

4. Start the engine then immediately open the water tap.

◆ **WARNING** : Do not touch any electrical part or jet pump area when engine is running.

▼ **CAUTION** : Never flush a hot engine. Always start the engine before opening the water tap. Otherwise, water will back flow through the tuned pipe into the engine and may cause damage to internal parts. Open water tap immediately after engine is started to prevent overheating. Follow this procedure exactly.

5. Run the engine about five minutes at a fast idle around 3500 RPM.

▼ **CAUTION** : Never run engine longer than five minutes. Drive line seal has no cooling when watercraft is out of water.

6. Remove plug from flame arrester cover.

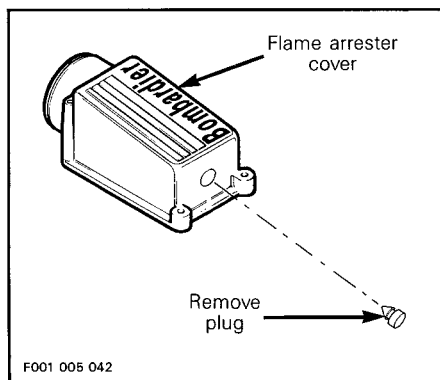

7. Spray some SEA-DOO LUBE (P / N 293 600 006) through flame arrester cover keeping engine at fast idle.

▼ **CAUTION** : Do not use out-board type storage lubricant. Using outboard lubricant may accelerate corrosion and damage engine components.

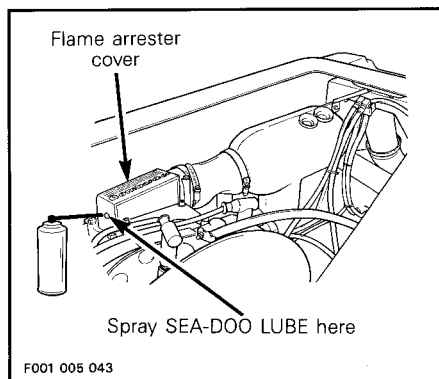

Lubrication of engine should be done at least for one minute. After approximately half a minute, close fuel tank valve to run engine out of fuel while lubricating.

▼ **CAUTION** : When engine begins to run irregularly because of fuel starvation, immediately stop water flow before engine dies. Severe engine damage could result if not done in this order.

8. Close the water tap then stop the engine.

▼ **CAUTION** : Always close the water tap before stopping the engine. Follow this procedure exactly otherwise severe engine damage could occur.

9. Press unlocking button to remove coupler hose. Reinstall dust cap over tee-fitting.
10. Wipe up any residual water on the engine.
11. Remove spark plug cables and connect them on the grounding device.

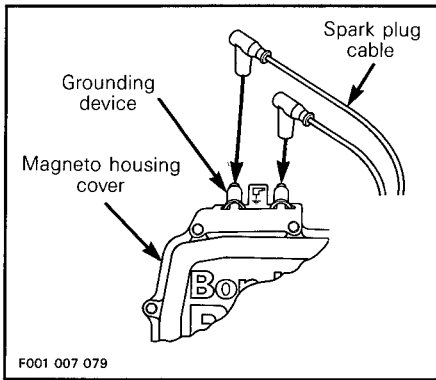

Remove both spark plugs and spray some SEA-DOO LUBE into each cylinder.

Crank the engine a few turns to distribute the oil on cylinder wall.

12. Apply anti-seize lubricant on spark plug threads then reinstall them.

13. Reinstall plug on flame arrester cover.

▼ **CAUTION** : Do not run the engine during the storage period.

Battery

Refer to the MAINTENANCE section under **Battery Removal** to remove and clean the battery. Apply some dielectric grease (P / N 293 550 004) or petroleum jelly on battery posts and all exposed cable connectors.

Add distilled water if necessary then give the battery a full charge at a maximum rate of two amperes.

Contact your authorized dealer or refer to the appropriate *Shop manual* for charging procedure.

Store the battery on a wood shelf in a warm dry place away from direct sunlight.

To prevent battery sulphating and discharging, have it charged every month.

Anticorrosion Treatment

Wipe off any residual water in the engine compartment.

Spray SEA-DOO LUBE over all metallic components in engine compartment.

Additional Recommended Protection

Cooling system may be filled with a 50 / 50 water / antifreeze solution.

▼ **CAUTION** : Always use ethylene glycol antifreeze containing corrosion inhibitors specifically recommended for aluminum engines.

NOTE : The engine will not have to run during this operation.

Three hoses have to be disconnected to allow air to escape and antifreeze solution to completely fill cooling system water jackets.

Install hose pincher on water injection hose.

Disconnect hoses where shown.

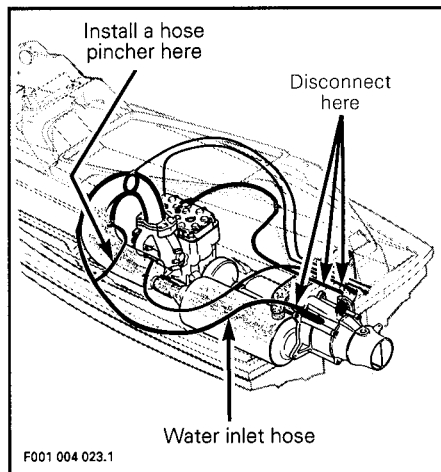

Raise all hoses above the highest point of tuned pipe and temporarily tie them together.

Insert a funnel into inlet hose going to the water inlet socket at tuned pipe. Pour about 2 liters (1/2 gal) of antifreeze solution through the funnel.

Tie up all hoses higher than tuned pipe.

NOTE : If hoses are not attached higher than tuned pipe, coolant will drain out.

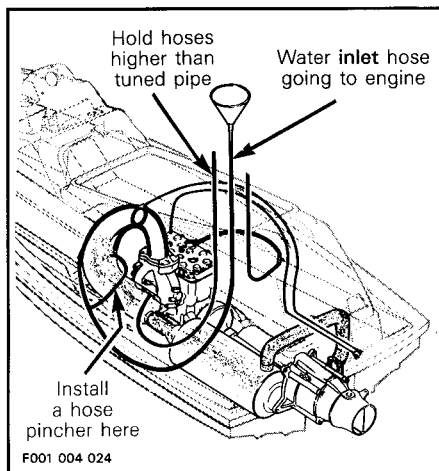

The following steps should be performed to provide the watercraft enhanced protection.

Remove muffler and drain out as much water as possible. Reinstall muffler.

OR : Disconnect one hose from muffler and pour some antifreeze liquid inside muffler. Reconnect hose.

Lubricate the throttle cable with SEA-DOO LUBE.

NOTE : A cable luber can be used on throttle cable end to inject SEA-DOO LUBE. Refer to a motorcycle parts supplier for availability.

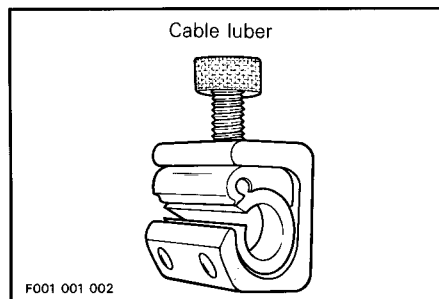

Clean the bilge with hot water and detergent or with bilge cleaner. Rinse thoroughly. Lift front end of watercraft to completely drain bilge. If any repairs are needed to body or to the hull contact your dealer. For paint touch up to mechanical parts use Bombardier spray paint. For small gelcoat repairs, a Bombardier repair kit is available. See **Accessories and Service products** section. Replace damaged labels / decals.

○ **NOTE** : Bilge cleaning should be done prior anticorrosion treatment.

Wash the body with soap and water solution (only use mild detergent). Rinse thoroughly with fresh water. Remove marine organisms from the hull. Apply a nonabrasive wax such as silicon wax.

▼ **CAUTION** : Never clean apparent fiberglass and plastic parts with strong detergent, degreasing agent, paint thinner, acetone, etc.

If the watercraft is to be stored outside, cover it with an opaque tarpaulin to prevent sun rays and grime from affecting the plastic components, watercraft finish as well as preventing dust accumulation.

▼ **CAUTION** : The watercraft must never be left in water for storage. Never leave the watercraft stored in direct sunlight. UV radiation will dull finishes.

The seat should be partially left opened during storage. This will avoid engine compartment condensation and possible corrosion.

○ **NOTE** : If the watercraft is stored outside with seat partially opened and without a tarpaulin, remove the rear drain plug in order to avoid water build up in the bilge during rainfall. Tilt the watercraft to the rear so that water can flow out of floorboard.

Pre-Season Preparation

Use the following chart.

Since technical skills and special tools are required, some operations should be performed by an authorized dealer.

◆ **WARNING** : Observe **WARNINGS** and **CAUTIONS** mentioned throughout this guide which are pertinent to the item being checked. When component conditions seem less than satisfactory, replace with genuine **BOMBARDIER** parts or approved equivalents.

Pre-Season Preparation Chart

| OPERATIONS | To be performed by |
|--------------------------------------------------------------------------------------|--------------------|
| Lubrication / corrosion protection | OPERATOR |
| Battery condition / charging and reinstallation | OPERATOR |
| Battery, starter connections and routing | DEALER |
| Spark plugs replacement (new ones) ① | OPERATOR |
| Impeller shaft reservoir oil inspection | DEALER |
| Propulsion system inspection | DEALER |
| New oil filter installation and bleeding | DEALER |
| Oil injection tank filling | OPERATOR |
| Flame arrester cleaning / inspection | DEALER |
| Fuel filter cleaning | DEALER |
| Fuel line condition | DEALER |
| Filler neck condition | DEALER |
| Throttle / choke cables inspection / adjustment | DEALER |
| Oil injection pump adjustment | DEALER |
| Engine ignition timing | DEALER |
| Carburetor(s) adjustments | DEALER |
| Steering column play / steering cable adjustment | DEALER |
| Water tank trap drains / bilge lines / pick-ups inspection (animals nest) | DEALER |
| Cooling system inlet / exhaust outlet hoses (animals nest) engine overheating beeper | DEALER |
| General inspection (hull, check valves, leaks, fasteners, attachments) | DEALER |
| Fire extinguisher condition / mounting | OPERATOR |

① Before installing new spark plugs, it is suggested to burn the excess SEA-DOO LUBE by starting the engine using the old spark plugs.

◆ **WARNING:** Only perform this operation in a well ventilated area. Coupler hose (P / N 295 500 099) must be installed or watercraft must be in water to cool engine. Running the engine without cooling water will damage exhaust hose interior and may damage engine.

TROUBLESHOOTING

The following chart is provided to help in diagnosing the probable source of simple troubles. Many problems can be quickly solved by you but other complicated ones required skilled mechanical technicians. In such cases, refer to an authorized dealer for servicing.

ENGINE WILL NOT START

| OTHER OBSERVATION | POSSIBLE CAUSE | REMEDY |
|---------------------------|--------------------------------------------------------------------------------------------------------------------------------------------------------------------------------------------------------------------------------------------------------------------------------------------------------------|--------------------------------------------------------------------------------------------------------------------------------------------------------------------|
| Engine does not turn over | <ul style="list-style-type: none"> • Tether cord removed • Fuse burnt • Discharged battery • Battery connections, corroded / loose • Water flooded engine | Install cap over switch. Check wiring then replace fuse. Charge / replace. Clean and tighten. Refer to Submerged Watercraft in SPECIAL PROCEDURES. |
| Engine slowly turns | <ul style="list-style-type: none"> • Discharged or weak battery | Charge / replace . |
| Engine turns over | <ul style="list-style-type: none"> • Fuel tank, empty or water-contaminated • Fuel filter, clogged or water-contaminated • Fuel flooded engine : <ul style="list-style-type: none"> -Fouled / defective spark plugs -Misuse of choke | Refill. Syphon and fill with fresh fuel. Clean, check fuel tank for water. Replace. Use only with cold engine. Replace spark plugs. |

ENGINE MISFIRES, RUNS IRREGULARLY

| OTHER OBSERVATION | POSSIBLE CAUSE | REMEDY |
|-------------------------------------------|--------------------------------------------------------------------------------------------------------------------------------------------------------------------|----------------------------------------------------------------------------------------------------------------|
| Weak spark | <ul style="list-style-type: none"> • Fouled / defective / worn spark plugs • Faulty RPM limiter • Too much oil supplied to engine | Replace. Refer to an authorized dealer. Improper oil pump adjustment, refer to an authorized dealer. |
| Lean fuel mixture | <ul style="list-style-type: none"> • Fuel : Level too low, stale or water-contaminated • Fuel filter, clogged or water-contaminated | Syphon and / or refill. Clean, check fuel tank for water. |
| Rich fuel mixture (high fuel consumption) | <ul style="list-style-type: none"> • Flame arrester dirty/clogged • Partially closed choke | Clean or replace. Refer to an authorized dealer. |

ENGINE OVERHEATS

| OTHER OBSERVATION | POSSIBLE CAUSE | REMEDY |
|---------------------------|--------------------------------------------------------------------------------------------------------------------------------------------------------------|-----------------------------------------------------------------------------|
| Overheating beeper sounds | <ul style="list-style-type: none"> • Clogged jet pump water intake • Incorrect type of fuel or oil • Clogged coolant system | Clean. Syphon and refill. Flush cooling system with coupler hose. |

ENGINE CONTINUALLY BACKFIRES

| OTHER OBSERVATION | POSSIBLE CAUSE | REMEDY |
|-------------------|-----------------------------------------------------------------------------------------|--------------------------------|
| | <ul style="list-style-type: none">• Faulty RPM limiter | Refer to an authorized dealer. |
| Weak spark | <ul style="list-style-type: none">• Fouled / defective / worn spark plugs | Replace. |
| Overheated engine | <ul style="list-style-type: none">• See ENGINE OVERHEATS | |

ENGINE PINGING OR KNOCKING

| OTHER OBSERVATION | POSSIBLE CAUSE | REMEDY |
|-------------------|-------------------------------------------------------------------------------------------------------------------------------|----------------------------------------------------------------------------------|
| | <ul style="list-style-type: none">• Poor quality gasoline / low octane• Spark plug heat range too high | Use well known quality and recommended gasoline. Use recommended spark plug . |

ENGINE LACKS ACCELERATION OR POWER

| OTHER OBSERVATION | POSSIBLE CAUSE | REMEDY |
|-------------------|--------------------------------------------------------------------------------------------------------------------------------|--------------------------------------------------|
| | <ul style="list-style-type: none">• Weak spark / incorrect fuel mixture• Water in fuel or injection oil | Refer to ENGINE MISFIRES. Syphon and replace. |
| Overheated engine | <ul style="list-style-type: none">• See ENGINE OVERHEATS | |

WATERCRAFT CAN NOT REACH TOP SPEED



| OTHER OBSERVATION | POSSIBLE CAUSE | REMEDY |
|-------------------|------------------------------------------------------------------------------------------------------------------------|---------------------------------------------------|
| | <ul style="list-style-type: none">• Cavitation, jet pump water intake clogged• Damaged impeller | Clean. Replace. Refer to an authorized dealer. |

ABNORMAL NOISE FROM PROPULSION SYSTEM

| OTHER OBSERVATION | POSSIBLE CAUSE | REMEDY |
|-------------------|------------------------------------------------------------------------------------------|--------------------------------|
| | <ul style="list-style-type: none">• Weeds or debris jammed around impeller | Clean and check for damage. |
| | <ul style="list-style-type: none">• Damaged impeller shaft or drive shaft | Refer to an authorized dealer. |

ACCESSORIES AND SERVICE PRODUCTS

These accessories and other fine products are available at your dealer.

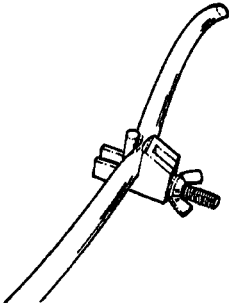
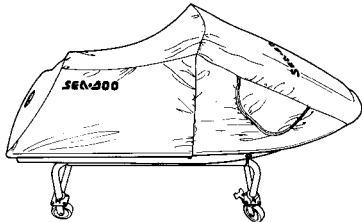
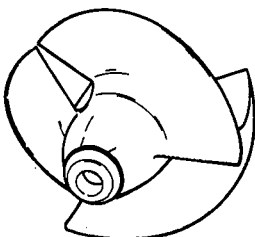
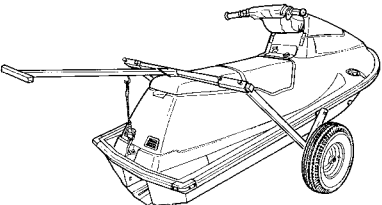
| ACCESSORIES | |
|---------------------------------------------------------------------------------------------------------------------------------------------------------------------------------------------------------------------------------------------------------|-------------------------------------------------------------------------------------------------------------------------------------------------------------------------------------------------|
| <p>Coupler Hose P / N 295 500 099</p>  <p>F001 004 035</p> | <p>Extinguisher P / N 298 770 000</p>  <p>F001 001 023</p> |
| <p>Hose Pincher P / N 295 000 076 (To be used when flushing)</p>  <p>A001 001 091</p> | <p>Sea-Doo Cover SP-SPI-SPX P / N 298 340 040</p>  <p>F001 001 024</p> |
| <p>Impeller (stainless steel)</p> <p>17.7° (polished) P / N 271 000 046 19.0° (mat) P / N 271 000 115 18.3° (mat) P / N 271 000 123</p>  <p>F001 001 022</p> | <p>Dolley</p> <p>Without wheels P / N 295 000 004 Beach wheel P / N 295 000 005</p>  <p>F001 001 008</p> |

ACCESSORIES

Fuel and Oil Gauge Kit
P / N 295 500 090

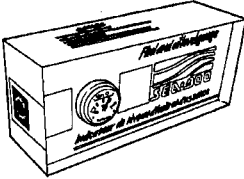

F002 001 001

Tachometer Kit
P / N 295 500 095

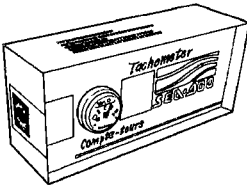

F002 001 004

Speedometer Kit
P / N 295 500 096

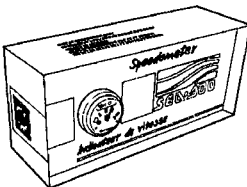

F002 001 005

First Aid Kit
P / N 298 775 000

Lift Kit
P / N 298 760 000

SP Grab Handle
Grey P / N 295 500 028
Mauve P / N 295 500 029

Tie-Down (purple)
Up to 1.50 m (5 ft) long
P / N 298 752 040
Up to 3.60 m (12 ft) long with Ratchet
P / N 298 753 040

Mirror
P / N 291 000 312

VTS Kit
P / N 295 500 091

SPI 1993 Kit
P / N 295 500 082

PRODUCTS

Synthetic Grease
P / N 293 550 010



F001 001 041

Dielectric Grease
P / N 293 550 004



F001 001 042

Jet Pump Synthetic Oil
P / N 293 600 011



F001 001 025

Anti-seize Lubricant
P / N 293 550 001



F001 001 043

Spray Paint for Metallic Parts Only

- Yellow P / N 293 500 008
- Mauve P / N 293 500 020
- Blue P / N 293 500 014
- White P / N 293 500 029
- Charcoal P / N 293 500 030



F001 001 026

Sea-Doo Lube
P / N 293 600 006



F001 001 028

PRODUCTS

Gelcote® Repair Kit
P / N 295 500 009



F001 001 027

Injection Oil
1 liter P / N 293 600 005
4 liters P / N 293 600 004

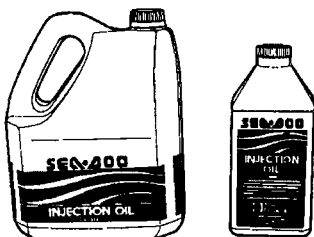

F001 001 044

Shop Manual
P / N 219 100 008

SPECIFICATIONS

| ENGINE | | SP (5806) SPI (5808) | SPX (5807) |
|---------------------------------|-------------------------|---------------------------------------------------------------------|------------------------------------------------|
| Engine type | | Rotax 2-stroke, type 587 | Rotax 2-stroke, type 587 |
| Induction type | | Rotary valve | Rotary valve |
| Exhaust system | | Water cooled / water injected | Water cooled / water injected |
| Lubrication | Type | Oil injection | Oil injection |
| | Oil type | SEA-DOO INJECTION OIL | SEA-DOO INJECTION OIL |
| Number of cylinders | | 2 | 2 |
| Bore | | 76.0 mm (2.992 in) | 76.0 mm (2.992 in) |
| Stroke | | 64.0 mm (2.520 in) | 64.0 mm (2.520 in) |
| Displacement | | 580.7 cm ³ (35.43 in ³) | 580.7 cm ³ (35.43 in ³) |
| Compression ratio | (corrected) | 5.9:1 | 5.9:1 |
| | (uncorrected) | 11.5 : 1 | 11.5 : 1 |
| Maximum torque (approximately) | | 64 N•m (47 lbf•ft) @ 5500 RPM | 65 N•m (48 lbf•ft) @ 5750 RPM |
| RPM limiter operation @ | | 6550 RPM ± 100 | 6550 RPM ± 100 |
| COOLING | | | |
| Type | | Water cooled, total loss type. Direct flow from propulsion unit. | |
| Overheating beeper, switch on @ | | 96-99°C (205-210°F) | 96-99°C (205-210°F) |
| ELECTRICAL | | | |
| Magneto generator output | | 160 W @ 6000 RPM | 160 W @ 6000 RPM. |
| Ignition system type | | Capacitor discharge ignition (breakerless) | |
| Spark plug | Make and type | NGK BR7ES | NGK BR7ES |
| | Gap | 0.5 - 0.6 mm (.020 - .024 in) | 0.5 - 0.6 mm (.020 - .024 in) |
| Starting system | | Electric starter | Electric starter |
| Ignition timing | BTDC | 2.65 mm (.104 in) (21° ± 1°) | 2.65 mm (.104 in) (21° ± 1°) |
| | Note | Checked with engine cold. Marks must align @ 6000 RPM. | |
| Battery | | 12 V, 19 A | 12 V, 19 A |
| Starting system fuse | | 5 A | 5 A |
| Charging system fuse | | 15 A | 15 A |
| CARBURETION | | | |
| Fuel type | | Regular unleaded gasoline | Regular unleaded gasoline |
| Carburetor | Type and number | Diaphragm type, quantity : 1 | Diaphragm type, quantity : 2 |
| | Low-speed mixture screw | ~1 Turn ± 1/4 | ~1-1/4 Turn ± 1/4 |
| Carburetor adjustments | Idle speed (in water) | 1400 RPM | 1400 RPM |

| PROPULSION | | SP (5806) | SPI (5808) | SPX (5807) |
|-------------------------------------------|---------------------------|-----------------------------------------------------------------|-----------------------|----------------------------|
| Propulsion system | | Bombardier Formula pump | | Bombardier Formula pump |
| Jet pump type | | Axial flow, single stage | | Axial flow, single stage |
| Impeller rotation (seen from rear) | | Counterclockwise | | Counterclockwise |
| Transmission | | Direct drive | | Direct drive |
| Coupling type | | Crown splines | | Crown splines |
| Impeller shaft reservoir, oil type | | SEA-DOO synthetic oil polyolester 75W90GL5 P / N 293 600 011 | | |
| Pivoting angle of direction (nozzle) | | ~26° | | ~26° |
| Minimum required water level for jet pump | | 60 cm | (2 ft) | 60 cm (2 ft) |
| Impeller diameter | | 139.5 cm | (5.49 in) | 139.5 cm (5.49 in) |
| Jet pump power (estimated) | | 13.28 kw (17.8 hp) | 13.65 kw (18.3 hp) | 15.14 kw (20.29 hp) |
| PERFORMANCE | | | | |
| Cruising time at full throttle | Fuel tank without reserve | ~1.45 Hour | | ~1.20 Hour |
| | Fuel tank reserve | ~20 Minutes | | ~13 Minutes |
| DIMENSIONS | | | | |
| Number of passengers ^① | | 1 operator and 1 passenger | | 1 operator and 1 passenger |
| Overall length | | 256 cm | (100.5 in) | 256 cm (100.5 in) |
| Overall width | | 105 cm | (41.5 in) | 105 cm (41.5 in) |
| Overall height | | 92 cm | (36.2 in) | 92 cm (36.2 in) |
| Mass | | 167 kg | (368 lb) | 168 kg (370 lb) |
| Load limit (passengers + luggage) | | 160 kg | (352 lb) | 160 kg (352 lb) |
| Hull Material | | Composite (Fiberglass) | | Composite (Fiberglass) |
| CAPACITIES | | | | |
| Fuel tank | | 33 L | (8.7 U.S. gal) | 33 L (8.7 U.S. gal) |
| Impeller shaft reservoir | Capacity | 65 mL | (2.2 U.S. oz) | 65 mL (2.2 U.S. oz) |
| | Oil level | Up to plug | | Up to plug |
| Injection oil reservoir | | 2.8 L | (95 U.S. fl. oz) | 2.8 L (95 U.S. fl. oz) |

① Refer to load limits.

BOMBARDIER INC. reserves the right to make changes in design and specifications and / or to make additions to, or improvements in its products without imposing any obligation upon itself to install them on its products previously manufactured.

SI* METRIC INFORMATION GUIDE

| BASE UNITS | | | |
|---------------------|--------------------|-------------------|----------|
| DESCRIPTION | UNIT | SYMBOL | |
| length | meter | m | |
| mass | kilogram | kg | |
| force | newton | N | |
| liquid | liter | L | |
| temperature | Celsius | °C | |
| pressure | kilopascal | kPa | |
| torque | newton-meter | N•m | |
| land velocity | kilometer per hour | km / h | |
| navigation velocity | knot | kn | |
| PREFIXES | | | |
| PREFIX | SYMBOL | MEANING | VALUE |
| kilo | k | one thousand | 1000 |
| centi | c | one hundredth of | 0.01 |
| milli | m | one thousandth of | 0.001 |
| micro | μ | one millionth of | 0.000001 |
| CONVERSION FACTORS | | | |
| TO CONVERT | TO ^① | MULTIPLY BY | |
| in | mm | 25.4 | |
| in | cm | 2.54 | |
| in ² | cm ² | 6.45 | |
| in ³ | cm ³ | 16.39 | |
| ft | m | 0.3 | |
| oz | g | 28.35 | |
| lb | kg | 0.45 | |
| lbf | N | 4.4 | |
| lbf•in | N•m | 0.11 | |
| lbf•ft | N•m | 1.36 | |
| lbf•ft | lbf•in | 12 | |
| PSI | kPa | 6.89 | |
| imp. oz | U.S. oz | 0.96 | |
| imp. oz | mL | 28.41 | |
| imp. gal | U.S. gal | 1.2 | |
| imp. gal | L | 4.55 | |
| U.S. oz | mL | 29.57 | |
| U.S. gal | L | 3.79 | |
| knot | MPH | 1.15 | |
| MPH | km / h | 1.61 | |
| Fahrenheit | Celsius | (°F - 32) ÷ 1.8 | |
| Celsius | Fahrenheit | (°C x 1.8) + 32 | |
| hp | kW | .75 | |

* The international system of units abbreviates SI in all languages.

① To obtain the reverse sequence, divide by the given factor. To convert "millimeters" to "inches", divide by 25.4.



NOTE: Conversion factors are rounded off to two decimals for easier use.

WATERCRAFT MODEL No. _____

HULL

IDENTIFICATION NUMBER (H.I.N.) _____

ENGINE

IDENTIFICATION NUMBER (E.I.N.) _____

Purchase Date _____ | _____ | _____ | _____ | _____
year month day

Warranty Expiry Date _____ | _____ | _____ | _____ | _____
year month day

To be completed by the dealer at the time of the sale

DEALER IMPRINT AREA

Please verify with your selling dealer to ensure your SEA-DOO watercraft has been registered with Bombardier.

NOTES _____

CHANGE OF ADDRESS

CHANGE OF OWNERSHIP

VEHICLE IDENTIFICATION NUMBER

Model Number Hull Identification Number (H.I.N.)

OLD ADDRESS
OR PREVIOUS OWNER :

NAME _____

NO _____ STREET _____ APT _____

CITY _____ STATE / PROVINCE _____ ZIP / POSTAL CODE _____

NEW ADDRESS
OR NEW OWNER :

NAME _____

NO _____ STREET _____ APT _____

CITY _____ STATE / PROVINCE _____ ZIP / POSTAL CODE _____



STAMP

BOMBARDIER INC.
SEA-DOO WARRANTY
VALCOURT, QUEBEC
CANADA J0E 2L0