

# Operator's Manual



P21900001 CA2001



219 000 001

WATERCRAFT MODEL No \_\_\_\_\_

HULL  
IDENTIFICATION NUMBER (H.I.N.) \_\_\_\_\_

ENGINE  
IDENTIFICATION NUMBER (E.I.N.) \_\_\_\_\_

Purchase Date \_\_\_\_\_  
  year        month        day

Warranty Expiry Date \_\_\_\_\_  
  year        month        day

To be completed by the dealer at the time of the sale

DEALER IMPRINT AREA

AFTER SALES SERVICE  
BOMBARDIER INC.  
VALCOURT, QUEBEC  
CANADA JOE 2LO

The following trademarks are property of  
Bombardier Inc. :

SEA-DOO\*  
ROTAX®

Armor All® is a trademark of Mc Kesson Corp. Irvine  
LPS#3® is a trademark of LPS Research Laboratories Inc.



# TABLE OF CONTENTS

---

<b>FOREWORD</b> .....	<b>3</b>
<b>THE SEA-DOO* WATERCRAFT LIMITED WARRANTY</b> .....	<b>4</b>
<b>WARRANTY QUESTIONS AND ANSWERS</b> .....	<b>6</b>
<b>SAFETY INFORMATION</b> .....	<b>8</b>
About the Navigation Laws and Regulations .....	<b>8</b>
Watercraft Operation, Safety Guidelines and Warnings .....	<b>8</b>
<b>WATERCRAFT IDENTIFICATION AND COMPONENTS</b> .....	<b>12</b>
Identification Numbers .....	<b>12</b>
Controls and Components .....	<b>13</b>
<b>FUEL/OIL AND BREAK-IN</b> .....	<b>21</b>
Recommended Fuel .....	<b>21</b>
Recommended Oil .....	<b>21</b>
Oil Injection System .....	<b>21</b>
Engine Break-in .....	<b>22</b>
10-hour Inspection .....	<b>22</b>
<b>DAILY PRE-OPERATION CHECKS</b> .....	<b>24</b>
Hull .....	<b>24</b>
Jet Pump Water Intake .....	<b>24</b>
Fuel/Oil Reservoirs and Filters .....	<b>25</b>
Fire Extinguisher .....	<b>25</b>
Engine Compartment .....	<b>25</b>
Battery .....	<b>25</b>
Bilge .....	<b>25</b>
Fasteners .....	<b>25</b>
Steering/Throttle Cables .....	<b>25</b>
Tether Cord/Engine Stop Button .....	<b>26</b>
Cloting .....	<b>26</b>
Obstacles .....	<b>26</b>
<b>OPERATING INSTRUCTIONS</b> .....	<b>27</b>
Principle of Operation .....	<b>27</b>
Starting from a Dock or in Shallow Water .....	<b>28</b>
Starting the Engine .....	<b>29</b>
Starting in Deep Water .....	<b>30</b>
Rough Water Operation .....	<b>31</b>
Docking .....	<b>31</b>
Beaching .....	<b>32</b>
Stopping the Engine .....	<b>33</b>

---

<b>POST-OPERATION CARE</b> .....	<b>34</b>
General Care .....	<b>34</b>
Additional Care for Unclean Water or Salt Water .....	<b>34</b>
<b>SPECIAL PROCEDURES</b> .....	<b>36</b>
Engine Overheat .....	<b>36</b>
Jet Pump Water Intake and Impeller Cleaning .....	<b>36</b>
Capsized Watercraft .....	<b>37</b>
Submerged Watercraft .....	<b>37</b>
Towing the Watercraft .....	<b>37</b>
Low-Charge Battery Condition .....	<b>37</b>
<b>MAINTENANCE</b> .....	<b>38</b>
Lubrication .....	<b>38</b>
Periodic Inspection .....	<b>39</b>
Periodic Inspection Chart .....	<b>40</b>
Spark Plug Cleaning and Adjustment .....	<b>41</b>
Throttle and Choke Cable Inspection .....	<b>41</b>
Carburetor Adjustment .....	<b>42</b>
Fuel and Oil Filters .....	<b>42</b>
Steering/Jet Pump Nozzle Adjustment .....	<b>45</b>
Bilge Draining Pick-Ups and Water-Trap Drains .....	<b>45</b>
Fuse Holder .....	<b>45</b>
Battery .....	<b>46</b>
General Inspection and Care .....	<b>48</b>
<b>TRANSPORTATION, STORAGE AND PRE-SEASON PREPARATION</b> .....	<b>49</b>
Transportation .....	<b>49</b>
Storage .....	<b>49</b>
Pre-season Preparation .....	<b>53</b>
<b>ACCESSORY AND SERVICE PRODUCTS</b> .....	<b>55</b>
<b>TROUBLESHOOTING</b> .....	<b>58</b>
<b>SPECIFICATION</b> .....	<b>60</b>
<b>SI METRIC INFORMATION GUIDE</b> .....	<b>62</b>

# FOREWORD

---

The operator manual has been prepared to acquaint the owner/operator or passenger of this personal watercraft with the various watercraft controls, maintenance and safe riding instructions. This manual is indispensable for the proper use of the product, and should be kept in a waterproof bag with the watercraft at all times.

For any questions pertaining to the warranty and its application, please consult the "WARRANTY QUESTIONS AND ANSWERS" section in this manual, or an authorized SEA-DOO dealer.

This manual uses the following symbols to emphasize particular information.

◆ **WARNING** : Identifies an instruction which, if not followed, might cause serious personal injuries including the possibility of death.

▼ **CAUTION** : Denotes an instruction which, if not followed, might severely damage the watercraft and/or components.

○ **NOTE** : Indicates supplementary information needed to fully complete an instruction.

Although the mere reading of such information does not eliminate the hazard, the understanding and application of the information will promote its correct use.

The information and components/system descriptions contained in this manual are correct at time of publication. Bombardier Inc. however, maintains a policy of continuous improvement of its products without imposing upon itself any obligation to install them on products previously manufactured.

Bombardier Inc. reserves the right at any time to discontinue or change specifications, designs, features, models or equipment without incurring obligation.

The illustrations show the typical construction of the different assemblies and, in all cases, may not represent the full detail or exact shape of the parts which have have the same or a similar function.

Specifications are given in the SI metric system with the SAE US equivalent in parenthesis. Where precise accuracy is not required, some conversions are rounded off for easier use.

A shop manual can be obtained for complete service, maintenance and repair information.

◆ **WARNING** : The engines and the corresponding components identified in this manual should not be utilized on product(s) other than those it is designed for. Maintenance procedures and specified tightening torques must be strictly adhered to. Never attempt repairs unless the appropriate tools are available. This watercraft is designed with parts dimensioned in the metric system. All fasteners are metric and must not be replaced by customary SAE US fasteners. Mismatched or incorrect fasteners could cause damage to the watercraft or possible personal injury.

# **THE SEA-DOO\* WATERCRAFT LIMITED WARRANTY (MODELS 5803/5810)**

---

## **1 - PERIOD**

BOMBARDIER® INC. as manufacturer, warrants FROM THE DATE OF SALE TO THE FIRST CONSUMER, every BOMBARDIER SEA-DOO Watercraft, models 5803/5810, sold as NEW AND UNUSED, and predelivered by an authorized BOMBARDIER® SEA-DOO dealer for a period of :

- 12 consecutive months for private use owners.
- 90 consecutive days for commercial use owners.

## **2 - WHAT BOMBARDIER WILL DO**

BOMBARDIER will repair and/or replace, at its option, components defective in material and/or workmanship (under normal use and service), with a genuine BOMBARDIER component without charge for parts or labour, at any authorized BOMBARDIER SEA-DOO dealer during said warranty period. All parts replaced under warranty become the property of BOMBARDIER INC.

## **3 - CONDITION TO HAVE WARRANTY WORK PERFORMED**

Present to the servicing dealer, the hard copy of the BOMBARDIER warranty registration card or proof of purchase received by the customer from the selling dealer, at time of purchase.

## **4 - EXCLUSIONS - ARE NOT WARRANTED**

- Normal wear on all items such as, but not limited to :
  - fuel filters
  - intake grates
  - impellers
  - Jets pump components worn out by cavitation
  - spark plugs
- Replacement parts and/or accessories which are not genuine BOMBARDIER parts and/or accessories.
- Damage resulting from the installation of parts other than genuine BOMBARDIER parts.
- Damage caused by failure to provide proper maintenance as detailed in the Operator's Manual. The labour, parts and lubricants costs of all maintenance services, including tune-ups and adjustments will be charged to the owner.
- Watercraft designed and/or used for racing purposes.
- All optional accessories installed on the watercraft. (The normal warranty policy for parts and accessories, if any, applies).
- Damage resulting from running the watercraft engine/impeller when the craft is out of the water.
- Damage resulting from modification to the watercraft not approved in writing by BOMBARDIER.
- Growth of marine organism on engine or hull surfaces.
- Gel coat/paint stress cracks.
- Losses incurred by the watercraft owner other than the parts and labour, such as, but not limited to, transportation, towing, telephone calls, taxis, or any other incidental or consequential damage.
- Damage resulting from accident, fire or other casualty, misuse, abuse or neglect.
- Damage/premature wear to the engine caused by water ingestion.
- Damage resulting from sand/stones infiltration in the jet pump area.

---

## **5 - BATTERY WARRANTY :**

- 12 consecutive months (pro-rated).

100% warranty coverage for the first 6 months will start on the date the watercraft was delivered. The remainder of the 12 month-period will be pro-rated as follows :

- 60% for the seventh (7) month.
- 50% for the eighth (8) month.
- 40% for the ninth (9) month.
- 30% for the tenth (10) month.
- 20% for the eleventh (11) month.
- 10% for the twelfth (12) month.

## **6 - EXPRESSED OR IMPLIED WARRANTIES**

**This warranty gives you specific rights, and you may also have other legal rights which may vary from state to state, or province to province. Where applicable this warranty is expressly in lieu of all other expressed or implied warranties of BOMBARDIER, its distributors and the selling dealer, including any warranty of merchantability or fitness for any particular purpose ; otherwise the implied warranty is limited to the duration of this warranty. However, some states or provinces do not allow limitations on how long an implied warranty lasts, so the above limitation may not apply.**

**Neither the distributor, the selling dealer, nor any other person has been authorized to make any affirmation, representation or warranty other than those contained in this warranty, and if made, such affirmation, representation or warranty shall not be enforceable against BOMBARDIER or any other person.**

**Some states or provinces do not allow the exclusion or limitation of incidental or consequential damages, so the above limitation or exclusion may not apply.**

**BOMBARDIER INC. reserves the right to modify its warranty policy at any time, being understood that such modification will not alter the warranty conditions applicable to watercraft sold while the above warranty is in effect.**

## **7 - CONSUMER ASSISTANCE PROCEDURE**

If a servicing problem or other difficulty occurs, we suggest the following :

1. Try to solve the problem at the dealership with the Service Manager or Owner.
2. If this fails, contact us as follows.

### **For Canadian customers ;**

BOMBARDIER INC.  
Marine Products Division  
Service department  
Valcourt, Québec, Canada JOE 2LO  
Tel. : (514) 532-2211

### **For American customers ;**

BOMBARDIER CORPORATION  
7575 PACKER DR.  
P.O. BOX 8035  
WAUSAU, WI.  
54402-8035  
Tel. : (715) 842-8886

August 1989

®\*Trademarks of Bombardier Inc.

# WARRANTY QUESTIONS AND ANSWERS

---

Q. Why must my watercraft be registered at the factory? After all I do have my original invoice as proof of when I purchase my watercraft.

A. *Your warranty is valid at any authorized dealer of the product. Your registration is the key element in providing the servicing dealer with the necessary data to complete warranty claim forms*

*The federal government required each manufacturer and dealer to maintain a complete up-to-date list of all first purchasers against the possibility of a safety-related defect and recall. This list is compiled from the purchase registrations sent to BOMBARDIER INC. by the selling dealer at the time of your purchase. If you have a change of address after the purchase of your new SEA-DOO, please advise us of your new address by sending a postcard listing your model number, dealer number (or dealer's name) as it is shown on your warranty card, your name and new mailing address.*

Q. What costs are my responsibility during the warranty period?

A. *The customer's responsibility includes all costs of normal maintenance services non-warranty repairs, accident and collision damages.*

Q. What is cavitation?

A. *This phenomenon is caused by a part travelling at high speed in a fluid (ex. : an impeller in water). The heat/bubbles generated in some areas are enough to draw microscopic particles from the material. Cavitation will increase if there are scratches or dents in the housing/impeller or if the wear ring worn.*

Q. Does the warranty cover the jet drive system components?

A. *Yes, if components replacement is not due to cavitation or normal wear. Ex. : The impeller has to be considered a wear item since tiny particles and sand contained in the water will eventually cause some wear. This situation occurs most often when the vehicle is driven in shallow water where rocks and debris can be drawn into the pump.*

*In order to extend the service life of the impeller housing, we have developed a replaceable wear ring around the impeller. It is made of plastic, therefore it may wear with use and should be replaced. This is a convenient feature and inexpensive to replace when compared to the impeller or pump housing. This replacement is considered normal maintenance and not covered by warranty.*

Q. What are some examples of neglect or abuse?

A. *These terms are general and overlap each other in areas. Specific examples include ; running the engine out of oil, operating the watercraft with a broken or damaged part, which causes another part to fail and so on. If you have any specific questions on operation or maintenance, please contact your SEA-DOO watercraft dealer for advice.*



---

Q. Does the warranty cover incidental costs such as transportation due to a failure ?

*A. No. The warranty is limited to repair of the SEA-DOO watercraft itself.*

Q. May I perform any or all of the recommended maintenance shown in the Operator's Manual instead of having the dealer do them ?

*A. Yes, if you are a qualified mechanic and follow the procedures specified in the Operator's and Shop Manuals. We do recommend however that the critical adjustments to timing and carburetion be done by a SEA-DOO dealer.*

Q. Will the warranty be void or cancelled if I do not operate or maintain my new SEA-DOO exactly as specified in the Operator's Manual ?

*A. No. The warranty on a new SEA-DOO cannot be "voided" or "cancelled". However, if a particular failure is caused by operation or maintenance other than as shown in the Operator's Manual, that failure may not be covered under warranty.*

Q. What responsibility does my dealer have under this warranty ?

- 1. Completely set up every new SEA-DOO watercraft before sale ;*
- 2. Explain the operation, maintenance and warranty requirements to your satisfaction at the time of sale. In addition, each SEA-DOO dealer is held responsible for set-up, service and warranty repair work.*

## **Customer Service**

If your SEA-DOO requires warranty service, you must take it to any authorized SEA-DOO dealer. Be sure to bring your warranty registration card or other valid proof of the original date of purchase. If a question or problem arises regarding warranty, first contact the owner of the SEA-DOO dealership.

Since all warranty matters are handled at the dealer level this person is in the best position to help you. If you are still not satisfied and require additional assistance, please write to :

### **For Canadian customers :**

BOMBARDIER INC.  
Marine Products Division  
Service department  
Valcourt, Quebec, Canada JOE 2L0  
Tél. : (514) 532-2211

### **For American customers :**

BOMBARDIER CORPORATION  
7575 PACKER DR.  
P.O. BOX 8035  
WAUSAU, WI  
54402-8035  
Tel. : (715) 842-8886

# SAFETY INFORMATION

---

PLEASE READ AND UNDERSTAND ALL WARNINGS AND CAUTIONS IN THIS MANUAL AND ON THE WATERCRAFT.

Prior to operating the watercraft, thoroughly read and understand the operator's manual, it will give necessary knowledge required to adequately operate this personal watercraft.

## About the Navigation Laws and Regulations

- Check local and federal boating laws and regulations in the area where the watercraft is to be used. Rules can be different pertaining to each state, province or country. It is recommended to follow a boating safety course.
- Operator and passenger must always wear a lifejacket. Its is recommended to use gloves, deck shoes/booties and a wet suit to help protect users against possible injuries.

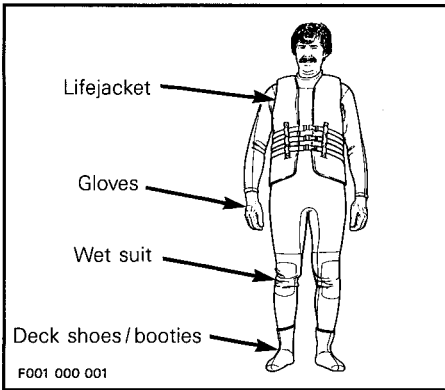

- An approved fire extinguisher must be present in the watercraft (space is provided in storage compartment).
- Operation by an unqualified minor is not recommended. A responsible adult should instruct and supervise a minor operating the watercraft.
- Operate in daytime only. This watercraft is not designed for night-time operation.
- Never operate the watercraft after consuming alcohol and/or drugs.

## Watercraft Operation, Safety Guidelines and Warnings

- For safety reasons and proper care, always perform "DAILY PRE-OPERATION CHECKS" as specified in this manual before operating the watercraft.
- After salt water use, particular care and lubrication have to be performed to neutralize salt action on watercraft and components. Refer to "POST-OPERATION CARE" under "Additional Care for Unclean Water and Salt Water" in this manual.

- 
- Operator should be sitting on the watercraft and firmly holding the handlebar before starting the engine.
  - Always securely attach the tether cord to the operator's lifejacket.
  - Throttle and steering mechanisms must be checked for free movement before starting engine.
  - Check fuel/oil levels and battery condition before operating the watercraft.
  - When starting or operating the engine, do not touch any electrical part.
  - The watercraft engine is stopped by pressing and holding the engine stop button until engine stops or by pulling the tether cord. If the engine is stopped because of an equipment malfunction, the source of this malfunction should be determined and corrected before restarting the engine.
  - When the engine is running, be careful not to have hands, feet or any part of clothing close to the jet pump water intake.
  - Never insert any object in the jet pump water intake or outlet.
  - To prevent accidental engine starting, always remove tether cord. Particularly when cleaning jet pump water intake area.
  - Remove debris from jet pump water intake only when engine is turned off and tether cord is removed.
  - An inexperienced operator should practice how to get aboard close to shore to simulate deep water boarding.
  - Watercraft should not be operated in less than 60 cm (2 ft) of water. Otherwise damage may occur to watercraft.
  - It is harmful and therefore not recommended to run the watercraft to the beach. Refer to "OPERATING INSTRUCTION" under "Beaching" in this manual.
  - Watch for dangerous near-surface or underwater obstacles/stones/weeds particularly while riding in shallow water.
  - It is not recommended to operate the watercraft within or around the surf-line.
  - Drive carefully and avoid riding close to swimmers.
  - when riding far it is recommended to be accompanied by another craft. Watch for and keep a safe distance from other craft.
  - Be careful before beginning a sharp turn, other craft operators may not expect that this watercraft can turn quickly.
  - Always keep in mind that as the throttle level is released, less directional control will be available. At idle or engine stop, there is no directional control. To turn the watercraft, steering must be turned and throttle applied.

- Since the engine cooling is in effect only when the watercraft is in the water, it is not recommended that the engine be allowed to idle for more than one minute without water supply. Prolonged such idling might cause engine damage as well as seal damage on drive shaft seal carrier.
- The operator should practice solo operation prior to giving a ride to a passenger.
- Watercraft carrying capacity is 160 kg (352 lb). Riding with a passenger makes the watercraft handle differently and requires more skill.
- Do not give a ride to someone if their feet can not reach the floorboard.
- The operator and passenger should keep their feet on the watercraft floorboard. The passenger should always hold the seat strap.
- A tow-rose should be kept at all time in the watercraft storage compartment.
- Always stop engine before refueling. Fuel may be under pressure and could spray out, remove fuel tank cap slowly. Gasoline is highly flammable and explosive under certain conditions. Refuel in a well ventilated area. Never refuel while smoking or in vicinity of open flame. If gasoline fumes are noticed, the cause should be determined and corrected without delay.
- Always check injection oil reservoir level when refueling.

- When inspecting the hull/jet pump, always rotate watercraft **counter-clockwise** (seen from the rear). Rotating watercraft clockwise could allow residual water in the tuned pipe to enter the engine and cause engine damage.

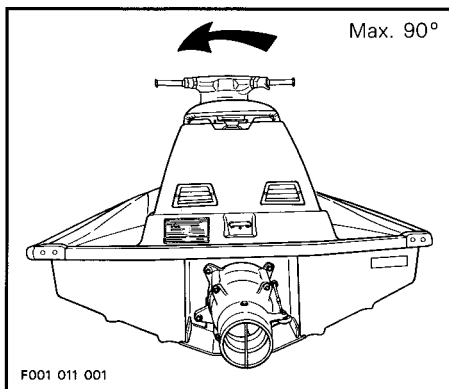

- Should water get into the engine immediately follow the procedure pertaining to "Submerged Watercraft" in the "SPECIAL PROCEDURES" section as specified in this manual. Should water be left in the engine for more than a few hours, engine internal parts will be damaged.
- Maintain the watercraft in top mechanical condition at all times.
- Installation of parts other than original equipment is not recommended. Avoid adding on accessories that alter the basic watercraft configuration including change in components location, altering vent tubes etc.

- 
- Whenever the watercraft is left outdoors for a long period, it is suggested to protect the watercraft from the weather with a SEA-DOO cover.
  - Only perform procedures as detailed in this manual. Unless otherwise specified, engine must be turned off and tether cord removed from switch for all maintenance.
  - Should removal of a locking device be required when undergoing repair/disassembly, always replace with new ones. Tighten fasteners as specified in the applicable shop manual.

**THIS MANUAL SHOULD REMAIN WITH THE WATERCRAFT AT THE TIME OF RESALE**

# WATERCRAFT IDENTIFICATION AND COMPONENTS

## Identification Numbers

The main components of the watercraft (engine and hull) are identified by different serial numbers. It may sometimes become necessary to locate these numbers for warranty purposes or to trace the watercraft in the event of theft.

The Engine Identification Number (E.I.N.) is located on the upper side of the magneto housing.

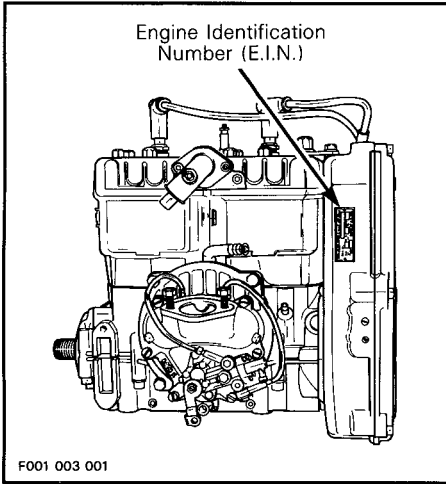

The Hull Identification Number (H.I.N.) is located at R.H. rear side of hull.

The watercraft model number can be found on U.S. Coast Guard approved label located on L.H. side of stern (rear) eyelet.

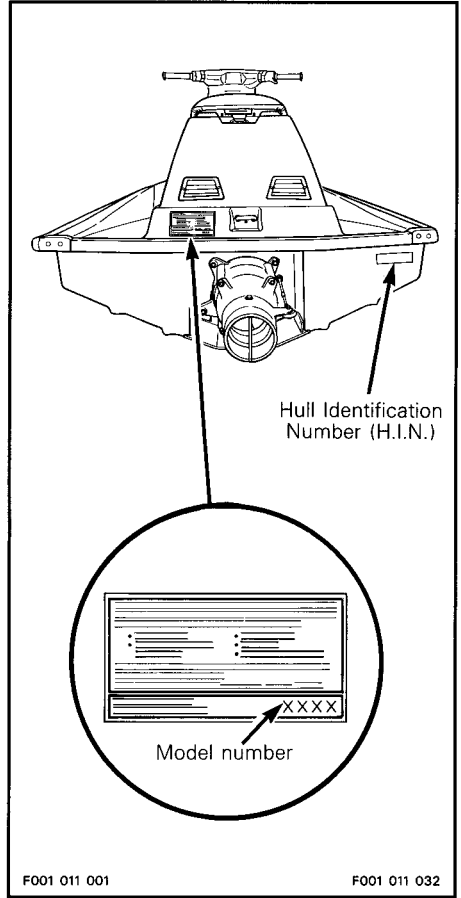

# Controls and Components

## CONTROLS AND COMPONENTS LOCATION

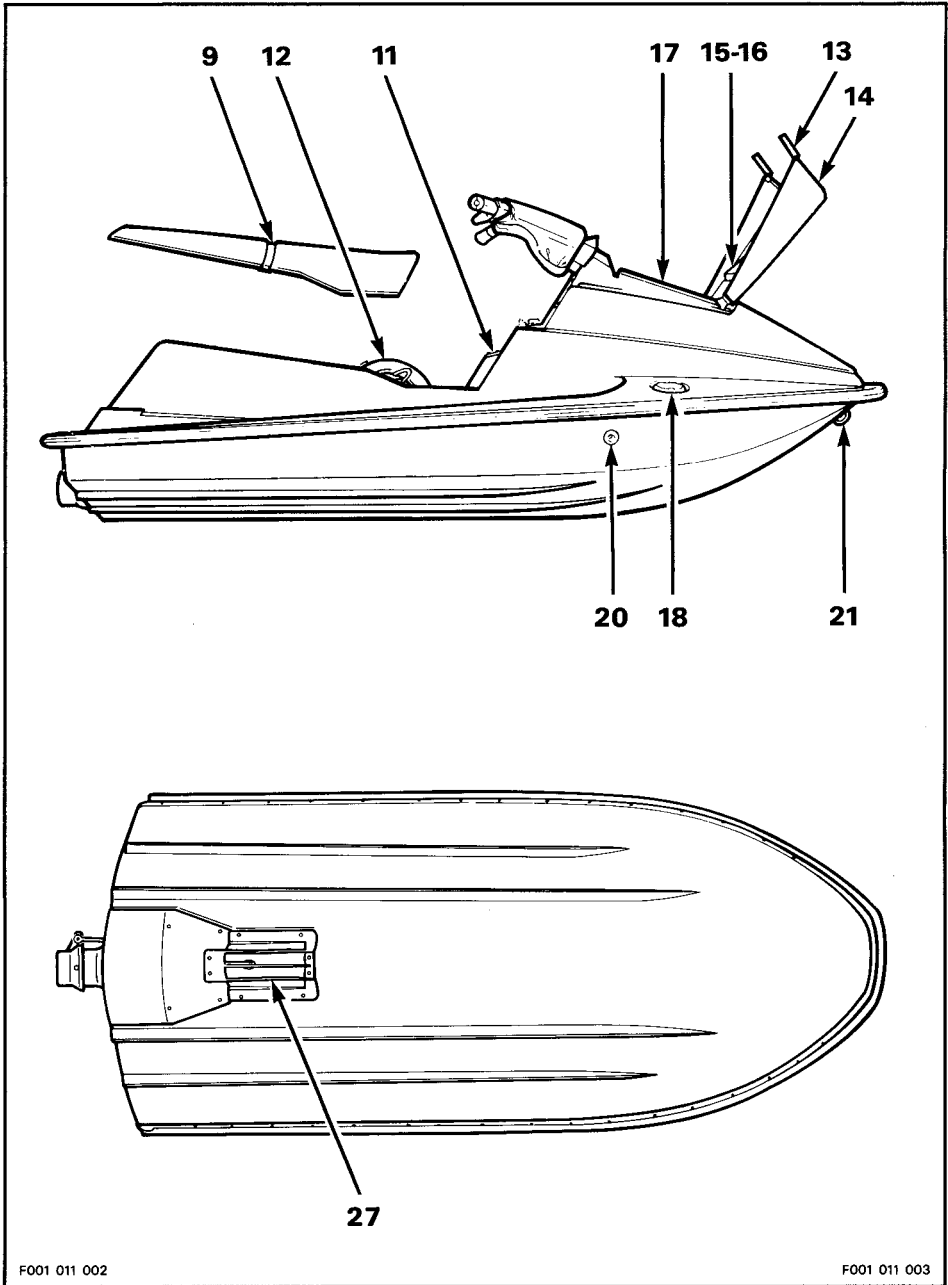

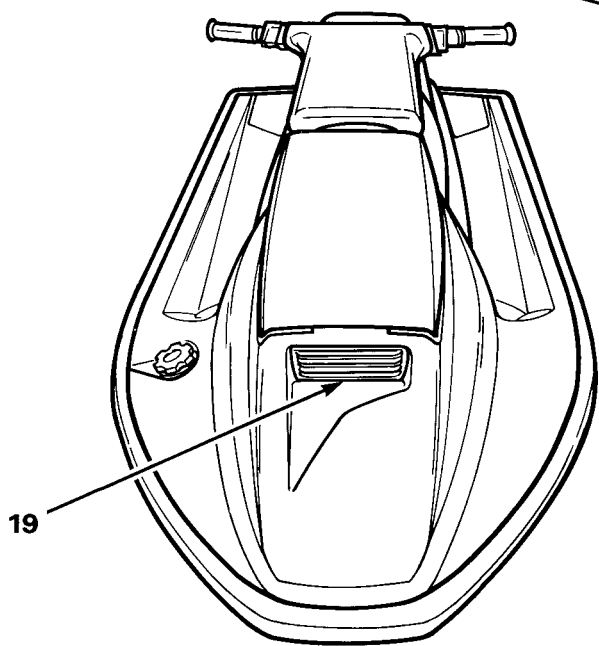
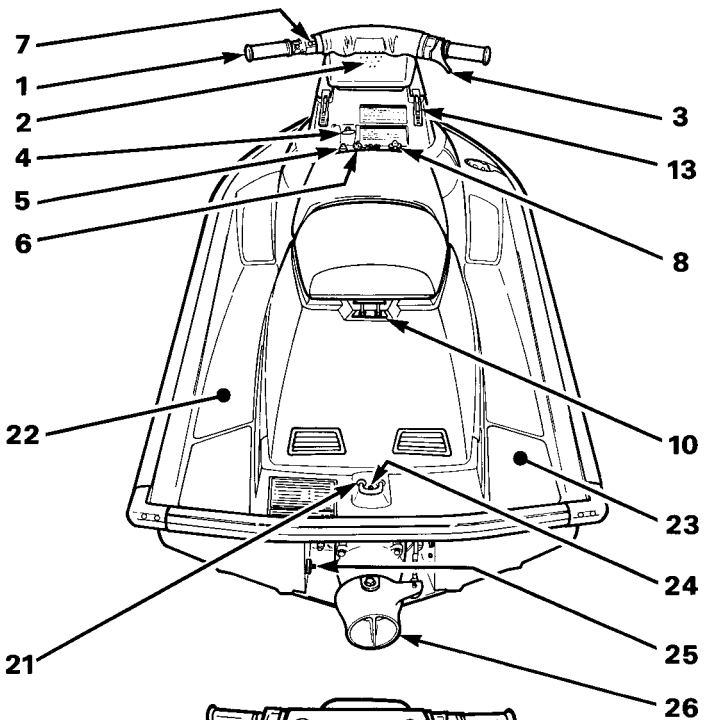



## 1) Handlebar

The handlebar controls the direction of the watercraft. Turning the handlebar to the right steers the watercraft to the right and inversely.

## 2) Overheating Beeper

In the event the engine overheats, a beeper (intermittent sound) will warn the operator.

## 3) Throttle lever

It controls the speed of the engine and therefore, the speed of the watercraft. When squeezed, engine accelerates. When fully released, engine automatically returns to idle speed and watercraft is gradually stopped by water drag.

## 4) Choke Knob

The choke is provided to supply a richer fuel/air mixture when starting a cold engine. When the knob is completely pulled, the choke is fully applied. The use of the choke is not recommended with a warm engine.

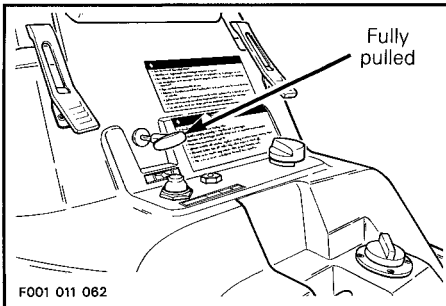

## 5) Starting Button

To start engine, depress and hold the button. Release immediately after engine is started.

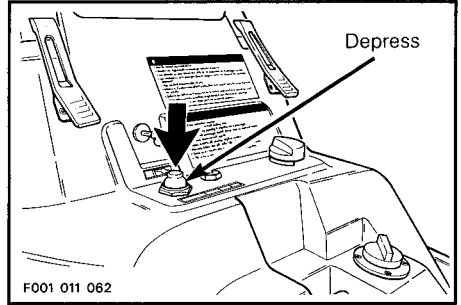

○ **NOTE :** Engine will not run if the tether cord is removed, even if the starter motor turns.

## 6) Tether Cord

Pulling the tether cord from the switch stops the engine operation. Attach the tether cord to the operator's lifejacket and snap the cap to the switch **before** starting the engine.

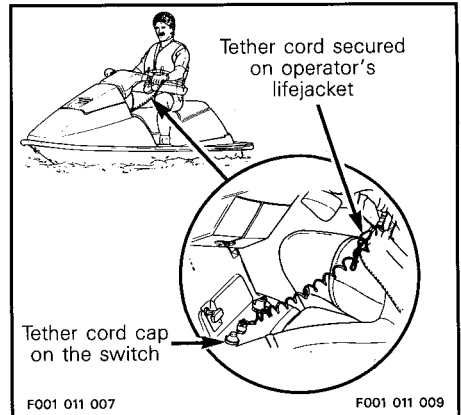

◆ **WARNING :** Should the engine be stopped, watercraft directional control will not be available. To prevent theft or unauthorized use, remove the tether cord from switch. Always reconnect tether cord as described.

## 7) Engine Stop Button

Located on left side of handlebar, this button is intended to stop engine when necessary. To use, fully release throttle lever then press the button **AND HOLD** until engine stops.

○ **NOTE** : Since it is a momentary switch, the button must be held until the engine has completely stopped.

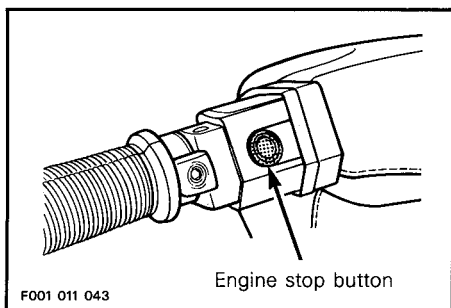

◆ **WARNING** : When the engine is stopped, watercraft directional control will not be available.

## 8) Fuel Tank Valve

A three-position rotating valve, OFF, ON, RES :

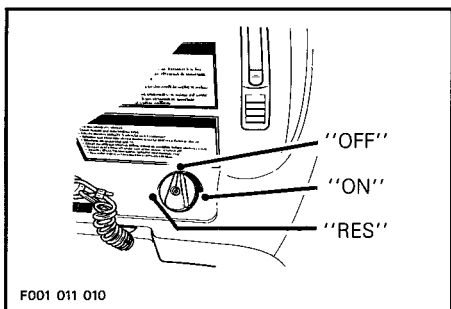

"OFF" : Stop fuel supply to carburetor.

▼ **CAUTION** : Must be used when watercraft is not operated, for transportation and storage.

"ON" : Allows fuel to flow to carburetor. This is the normal position for operation of watercraft. With a full fuel tank, the watercraft can run approximately two hours at full throttle before running out of gas (in the "ON" position).

"RES" : Use when the watercraft has run out of gas in the "ON" position. Allow approximately 1/2 hour operation at full throttle before running out of gas.

◆ **WARNING** : Always refill the fuel tank at the first opportunity. After refueling, turn the fuel valve to the "ON" position for further operation.

## 9) Seat strap

The seat strap provides a handhold when needed for boarding and a handhold for the passenger.

## 10) Seat Opening

Removing the seat allows access to the engine compartment and to oil reservoir cap and dipstick.

The seat latch is located at the rear end and underneath the seat.

To remove seat, pull the latch lever upward and hold. Lift and pull the seat rearward.

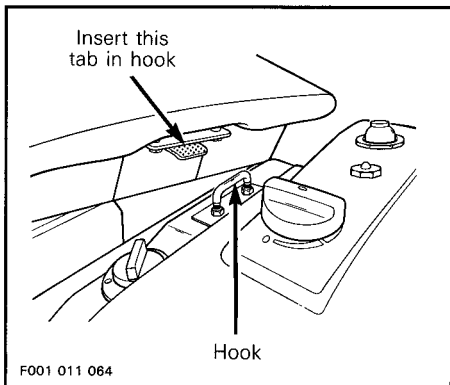

when re-installing the seat, insert seat front tab into body hook.

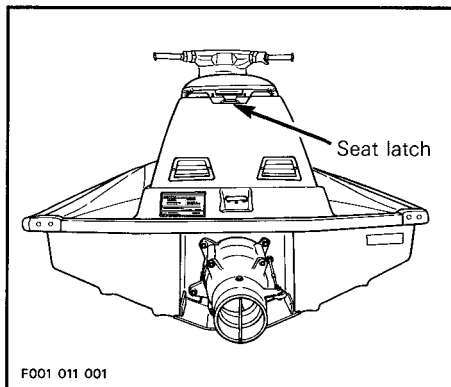

Pull latch lever to insert it over the rear hook. Release latch lever then firmly push on rear of the seat to re-latch.

NOTE : Periodically verify the seat hooks upper nuts and lock nuts, tighten if needed. Make sure seat is securely latched.

## 11) Oil injection Reservoir Gauge/Cap

NOTE : Seat has to be removed to expose oil cap.

Unscrew the cap counter-clockwise then pull to expose the dipstick.

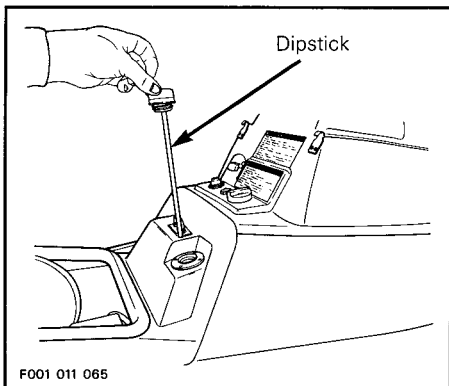

The dipstick indicates the amount of oil to be added in the reservoir. Oil level should be maintained between "FULL" and "ADD" marks. To check, have the watercraft level, wipe the dipstick then insert in the reservoir neck. Do not screw cap. Remove dipstick and read the level.

## 12) Engine Compartment

NOTE : Seat has to be removed to access engine compartment.

This is where the engine, fuel/oil filters, battery, fuse, jet pump drive shaft, bilge pick-ups etc. are located.

WARNING : When starting or operating the engine, do not touch any electrical part. Never leave any object, rags, tools etc. in the engine compartment or in the bilge.

### 13) Cover Latches

Pull down the latches in order to open the storage compartment cover. Always re-latch.

### 14) Storage Compartment Cover

Gently lift cover. Cover contains the tool kit and the operator's manual. It gives access to the storage compartment. Always secure cover latches after closing.

### 15) Tool kit

Contain tools needed to perform basic watercraft maintenance.

### 16) Operator's Manual

Should be kept in a waterproof bag and remain with the watercraft at all times. It should be given with watercraft when resold.

### 17) Storage Compartment

A convenient water-tight, removable basket to carry personal articles. Ideal location for spare sparks plugs, tow-rope, first aid kit etc. Re-install basket as shown.

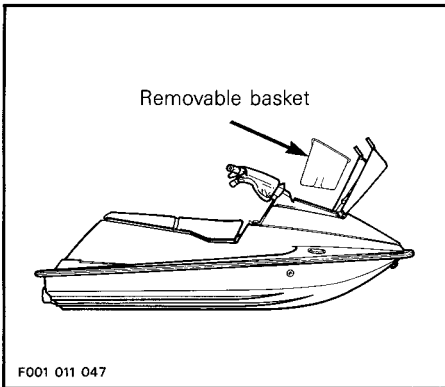

◆ **WARNING :** Never leave any heavy or breakable object in the storage basket. Never store or carry anything below basket.

This area is the preferred location to install an approved extinguisher. Follow fire extinguisher manufacturer's instructions to install the mounting bracket. The extinguisher should be located in the rear center portion of the basket. Fire extinguisher should not be left loose in the storage compartment.

### 18) Fuel Tank Cap

Unscrew the cap counter-clockwise to allow fuel tank filling. Fully tighten when finished.

◆ **WARNING :** Never use a lit match or open flame to check fuel level. Remove fuel tank cap slowly. Fuel might be under pressure and could spray out when removing cap.

### 19) Air Intake Opening

This is where air enters to supply the engine and ventilate the engine compartment.

### 20) Water-trap Drains

If water enters the air intake opening, a water-trap with a baffle separates water from the air then evacuates the water through two drain hoses, one on each side of the hull.

### 21) Bow/Stern (front/rear) Eyelets

Eyelets can be used for mooring, towing and tie-down points for transportation.

## 22) Floorboard

It is conveniently covered with anti-skid surface. Users' feet should rest on the floorboard when riding.

## 23) Boarding Pads

Provide a cushioned surface for the knees when boarding from rear of watercraft.

## 24) Cooling System Bleed Outlet

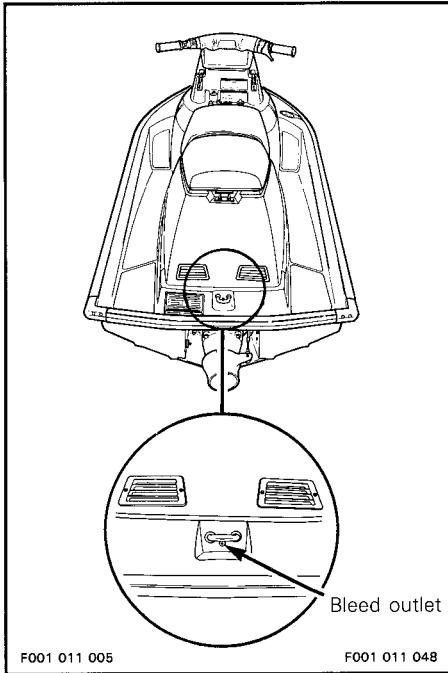

When engine is running, water must flow this hole. This allows air in tuned pipe water jacket to escape.

▼ **CAUTION:** Should water not flow from this outlet a few seconds after engine starts, immediately stop engine and refer to an authorized dealer for servicing.

## 25) Bilge Drain Plug

Should water be found in the bilge, it can be easily drained by removing this plug.

◆ **WARNING:** Remove watercraft from water prior to removing the drain plug.

Release the lever then remove plug.

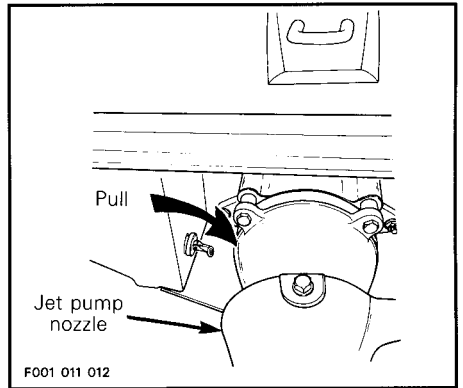

Lean the watercraft slightly to the rear so that the water can completely flow out of the bilge.

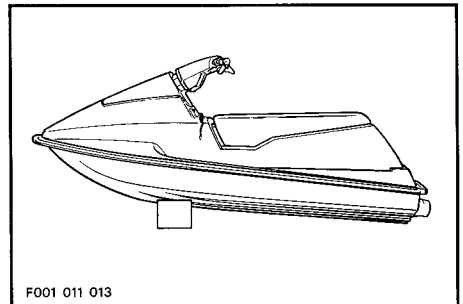

○ **NOTE :** Should the plug become too loose in its hole, hold the plug then with the level pulled, turn the lever clockwise to tighten (counter-clockwise to slacken). Adjust to have a water-tight fit.

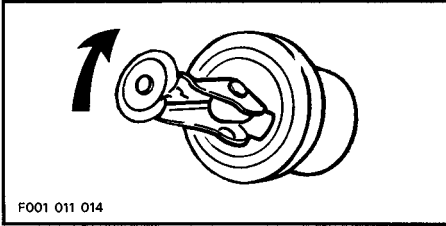

Reinstall bilge drain plug and fully push the plug lever to locked position.

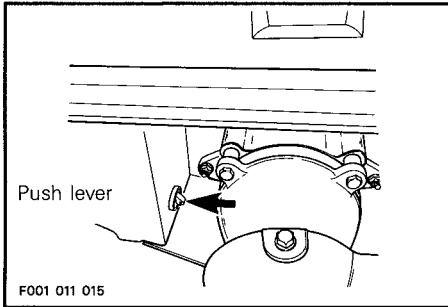

◆ **WARNING :** Always make sure bilge drain plug is properly installed in the drain hole and lever is safety locked.

## 26) Jet Pump Nozzle

It is turned from side to side via rider input at the handlebar. This provides watercraft directional control.

## 27) Jet Pump Water Intake

The water is drawn up by the impeller through this opening. The impeller and the drive shaft are protected by a grill.

# FUEL/OIL AND BREAK-IN

---

## Recommended Fuel

Use regular **unleaded** gasoline.

○ **NOTE** : No oil has to be mixed with the gasoline. Always check injection oil reservoir level when refueling.

The use of a small flexible spout or a funnel will ease the fuel tank filling. Pour gasoline slowly so that air can escape from the the reservoir and prevent gasoline flowback.

Fill fuel tank to bottom of filler neck. Do not overfill.

▼ **CAUTION** : Do not lean the watercraft to allow more fuel to fill the fuel tank. The tank design makes provision for gasoline expansion of about 5 %. If this area is filled, gasoline will expand the fuel tank. Keep watercraft horizontal while fueling.

Fully tighten fuel tank cap and wipe off any gasoline spillage.

◆ **WARNING** : Always stop the engine before refueling. Remove fuel tank cap slowly. Fuel may be under pressure and could spray out when removing cap. Gasoline is flammable and explosive under certain conditions. Always work in a well ventilated area. Do not smoke or allow open flames or sparks in the vicinity. Never experiment with other fuels or fuel ratios. The use of gasoline containing alcohol, methanol or similar products including naphta is not recommended. The use of unrecommended fuel can result in watercraft performance deterioration and damage to critical parts in the fuel system and engine components. Never top off the fuel tank and leave watercraft in the sun. As temperature increases, gasoline expands and might overflow. Always wipe off any gasoline spillage from the watercraft.

## Recommended Oil

It is highly recommended to use SEA-DOO INJECTION OIL (P/N 293 600 005 - 1L or 293 600 004 - 4L) wich is available from authorized dealers. It is a blend of specially selected base oils and additives which provides outstanding lubrication, engine cleanliness and minimum spark plug fouling.

▼ **CAUTION** : Never use stright mineral oil.

## Oil Injection System

This watercraft features an oil injection system and does not require manual gasoline/oil mixing.

Oil level should be maintained between "FULL" and "ADD" of dipstick marks. To check, remove seat to expose oil cap, unscrew cap, wipe dipstick then insert in the reservoir neck. Do not screw cap. Remove dipstick and read the level. Add oil as necessary.

Use a flexible funnel to pour oil into reservoir. Wipe off any oil spillage.

▼ **CAUTION** : Always maintain a sufficient amount of injection oil in the oil reservoir. Check and refill every time you refuel. Do not overfill. If the engine is run out of oil, severe engine damage will occur. If the oil tank is found almost empty, immediately refer to an authorized dealer to have the oil injection system inspected.

---

## Engine Break-in

With Bombardier-Rotax watercraft engines, a break-in period is required before operating the engine at full throttle. Engine manufacturer recommendation is about 10 operating hours.

During this period, maximum throttle should not exceed  $3/4$ , however, brief full acceleration and speed variations contribute to a good break-in. Continued wide open throttle accelerations, prolonged cruising speeds and overloading the engine are detrimental during the break-in period.

To assure additional protection during the initial engine break-in, 500 mL of SEA-DOO INJECTION OIL should be added in the fuel tank **for the first full fuel tank filling only.**

 **CAUTION:** Remove and clean spark plugs after engine break-in.

## 10-Hour Inspection

It is suggested that after the first ten hours of operation, the watercraft be checked by an authorized dealer. This inspection will also provide the opportunity to discuss the unanswered questions the operator may have encountered during the first hours of operation.

---

**The 10-hour inspection is at the expense of the watercraft owner. Inspection takes approximately 2.5 hours.**

---



<b>10-HOUR INSPECTION CHECK LIST</b>	<b>✓</b>
Engine ignition timing if required	
Spark plug inspection, cleaning and adjustment	
Fuel system lines and fasteners/pressurize test	
Carburetor adjustment including throttle/choke cables if required	
Oil injection system lines	
Oil injection pump adjustment if required	
Engine cradle and engine rubber mounts	
Muffler, battery and reservoirs fastening devices	
Exhaust system hose clamps	
Carburetor flange nuts & flame arrester bracket	
Handlebar clamp nuts	
Steering cable adjustment if required	
Hoses condition & fasteners	
Bilge lines and filters, check for obstructions	
Tether cord/engine stop button operation, engine overheating beeper	
Electrical connections (starter, battery, etc.)	
Impeller shaft reservoir oil replacement	
Impeller condition, impeller/wear ring clearance	
Drive shaft, lubricate grease fittings at flywheel	
Water intake grill/hull condition	
Inspection of fasteners for tightness	
Inspect/clean engine drain tube	

**We recommend that this inspection chart be signed by an authorized dealer**

\_\_\_\_\_  
Date of 10-hour inspection

\_\_\_\_\_  
Authorized dealer signature

# DAILY PRE-OPERATION CHECKS

---

Some of the following items may not have been previously covered in this manual, however they will be described in the "MAINTENANCE" or "SPECIAL PROCEDURES" section. Please refer to these portions to have more detailed information.

Every day the watercraft is to be operated, perform the following checks.

ITEM	OPERATION	✓
Hull	Inspect	
Jet pump water intake	Inspect/clean	
Bilge	Drain. Ensure plug is secured	
Battery	Inspect electrolyte level/connections	
Fasteners	Visually inspect for tightness	
Fuel/oil reservoirs and filters	Refill/visually inspect	
Engine compartment	Verify fuel/oil system components	
Fire extinguisher	Inspect condition/mounting.	
Steering/throttle cables	Check operation	
Tether cord/engine stop button	Check operation	

## Hull

Inspect hull for cracks or damage.

## Jet Pump Water Intake

**◆ WARNING :** Tether cord must always be removed from switch prior to performing the following operation.

Remove weeds, shells, debris or anything else that could restrict the flow of water and harm cooling system or propulsion unit. Clean as necessary. If any obstruction can not be removed, refer to an authorized dealer for servicing.

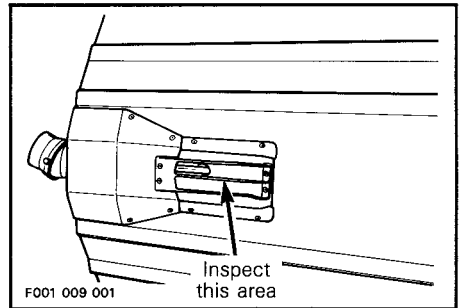

## Bilge

Should water be present in the bilge, have the watercraft leaned to the rear and remove drain plug to completely empty the bilge.

○ **NOTE** : Remove bilge draining pick-ups, clean then and reinstall.

◆ **WARNING** : Make sure to take the watercraft out of water prior to removing the drain plug.

Reinstall bilge drain plug and fully push the plug lever to lock.

## Battery

Make sure electrolyte level is at the HIGHEST level line, that battery connections are not loose and there are no leaks.

○ **NOTE** : Ensure the watercraft is level before checking battery electrolyte level.

◆ **WARNING** : Verify tightness of battery, starter cable terminals.

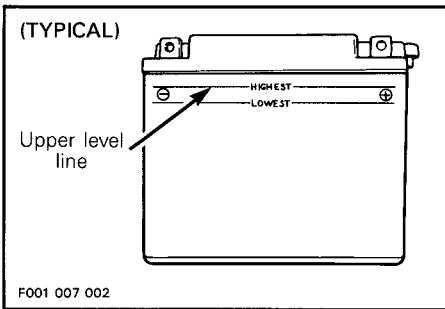

## Fasteners

Retighten fasteners as necessary. Ensure all latches are securely locked.

## Fuel/Oil Reservoirs and Filters

With the watercraft horizontal, fill the fuel tank to specified level with gas.

Clean the fuel filter as necessary to remove any possible water or foreign particles.

◆ **WARNING** : Make sure fuel filter is properly reinstalled and does not leak.

Check the oil inspection level and refill reservoir as necessary.

Visually inspect oil filter for foreign particles or water.

## Engine Compartment

Check condition of fuel/oil system components.

◆ **WARNING** : Should any leak be present, do not start the engine or operate the watercraft, immediately refer to an authorized dealer.

## Fire Extinguisher

Make sure it is full, in good condition and well secured.

## Steering/Throttle Cables

Check steering operation for free movement. When the handlebar is horizontal, the jet pump nozzle should be in the straight ahead position. Ensure the jet pump nozzle pivots easily while handlebar is turned.

Check throttle lever several times for free and smooth operation without any hesitation through all its stroke. It must return to its initial position immediately after released.

◆ **WARNING** : Perform this check before starting the engine.

## Tether Cord/Engine Stop Button

Ensure that both switches operate properly. Start engine and stop it using each switch individually.

◆ **WARNING** : If engine does not stop after one switch has been used, try the other one. If engine still run, fully pull the choke knob to flood the engine. If it does not work, turn the fuel valve to "OFF". Do not operate the watercraft, refer to an authorized dealer.

○ **NOTE** : Since the engine is started for this operation, this gives a good opportunity to have an idea of the battery charge. Pay particular attention when starting, engine should easily rotate and turn at a steady speed. Otherwise, give the battery a charge or replace it if necessary.

◆ **WARNING** : Should the engine slowly rotate when cranking, it probably indicates a poor battery. Do not operate the watercraft with a low-charge battery.

## Clothing

Always wear a Coast Guard approved lifejacket whenever operating a watercraft. It is also recommended that gloves, wet suit and deck shoes/booties be worn when operating in cooler temperatures.

## Obstacles

Verify that the path ahead of the watercraft is clear of craft or obstacles. Avoid riding close to swimmers. Always check local boating laws for legal and safe operation.

◆ **WARNING** : Only start the watercraft once all times have been checked, operate properly and are free of damage.

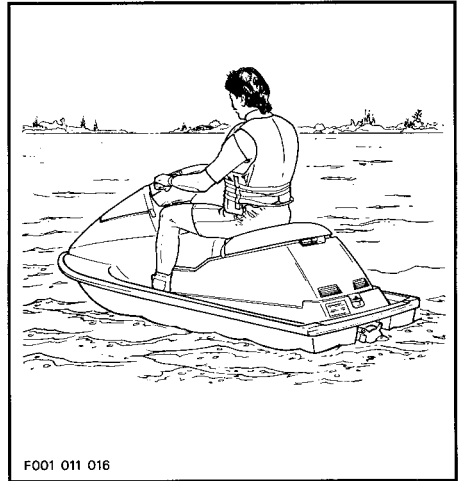

# OPERATING INSTRUCTIONS

**WARNING :** Always perform "DAILY PRE-OPERATION CHECKS" before operating the watercraft and become thoroughly familiar with all controls and the function of each. Should any control or instruction be not fully understood, refer to an authorized dealer to get complete information.

## Principle of Operation

### Propulsion

The engine is directly coupled to a drive shaft which, in turn, rotates an impeller. This impeller is accurately adjusted in a housing where the water is drawn up from underneath the watercraft. Then the water flows through the impeller to a venturi. The venturi accelerates the water and produces thrust to move the watercraft. Depressing the throttle lever increases engine speed and therefore watercraft speed.

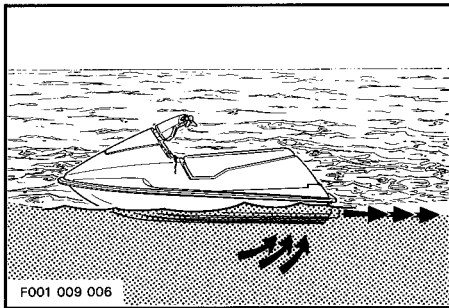

**WARNING :** It is important to keep in mind that as soon as the engine is running the jet pump is constantly producing a thrust causing the watercraft to move forward. Therefore, whenever the engine is to be started, the operator should always be sitting on the watercraft.

### Turning

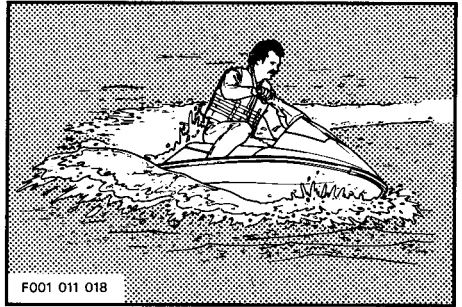

Turning the handlebar pivots the jet pump nozzle which controls the watercraft direction. Turning the handlebar to the right will turn the watercraft to the right and inversely. However, the throttle must be applied to turn the watercraft.

**WARNING :** When operating the watercraft, it is important to always keep in mind that directional control is lost when the throttle is closed. Throttle must be applied and handlebar turned to change the direction of the watercraft.

The more the throttle is applied while turning the handlebar, the sharper the turn will be.

Practice these maneuvers to have a good feel of the watercraft operation.

This watercraft is designed for one operator and one passenger. The watercraft behaves differently with a passenger and requires more skill. The passenger should always grip the seat strap. Reduce the operation speed and avoid sharp turns. Avoid choppy water conditions when carrying a passenger.

## Starting from a Dock or in Shallow Water

Perform "DAILY PRE-OPERATION CHECKS" procedures.

Launch the watercraft.

◆ **WARNING** : Since the engine is directly coupled to the jet pump, the watercraft moves forward even with the throttle closed when the engine is running.

Attach the tether cord to the operator's lifejacket and snap the cap to the switch before starting the engine.

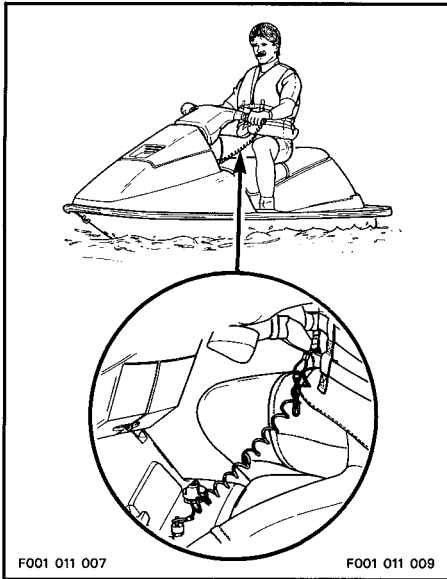

As with any craft, getting aboard should be done carefully.

When boarding from a dock, slowly place one foot on the watercraft side along the dock and, at the same time, transfer the body weight to the other side in order to balance the watercraft while holding the handlebar. Then, bring the other foot over the seat and put it on the other side of the floorboard. Push the watercraft away from the dock.

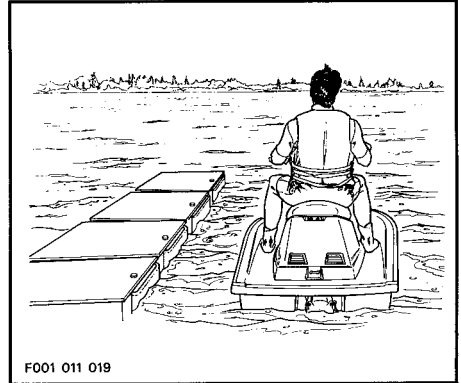

▼ **CAUTION** : The engine should be started with at least 60 cm (2 ft) of water below the hull.

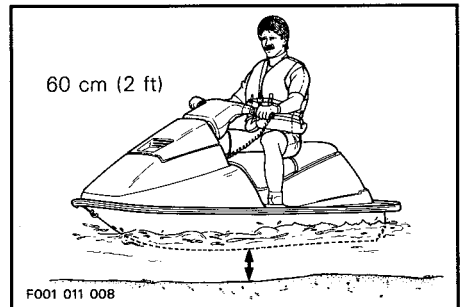

In shallow water, board the watercraft either from the side or the rear.

◆ **WARNING :** An inexperienced operator should practice how to get aboard close to the shore to simulate deep water boarding.

Slowly accelerate to reach deeper water.

▼ **CAUTION :** Do not perform a powerful acceleration when the watercraft is in shallow water. Otherwise shells, sand, pebbles or other objects could be drawn up by the jet pump and damage impeller, components or clog cooling system as well as jamming.

## Starting the Engine

▼ **CAUTION :** Engine should always be started with the watercraft in water. At least 60 cm (2 ft) of water should be present below the hull.

◆ **WARNING :** Since the engine is directly coupled to the jet pump, the watercraft moves forward even with the throttle closed when the engine is running.

### Cold engine

Operator (and passenger if applicable) should be sitting on the watercraft prior to starting the engine.

Turn the fuel valve to "ON".

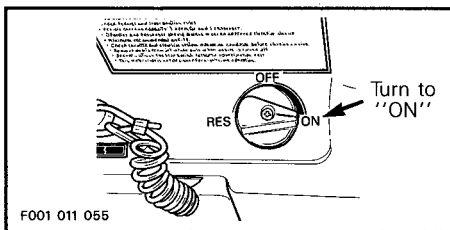

Fully pull the choke knob.

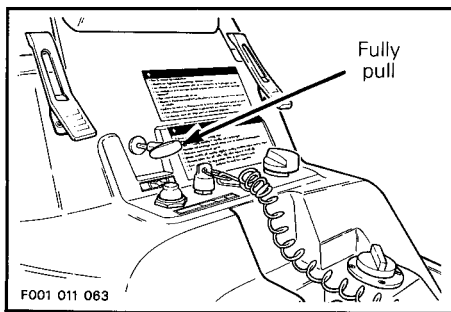

firmly grip handlebar and place both feet on the floorboard. Depress the starting button.

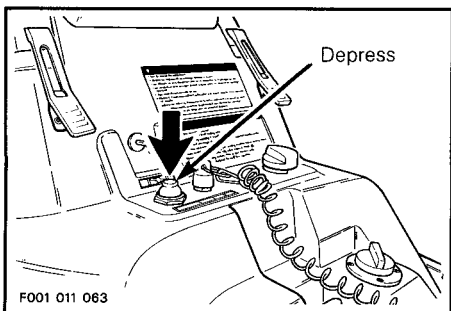

○ **NOTE :** Do not depress the throttle level while starting a cold engine.

▼ **CAUTION :** To avoid starting motor overheating, the cranking period should not exceed 5-10 seconds and a rest period should be observed between cranking cycles to let the starter coil down and its mechanism disengage. Never depress the starting button when the engine is running.

Immediately after engine is started, release starting button.

A few seconds after, push the choke knob and of necessary, slightly apply throttle to keep engine running. Do not apply full throttle until the engine is warm.

### Warm Engine

The same procedure as a cold engine applies except the choke does not need to be applied.

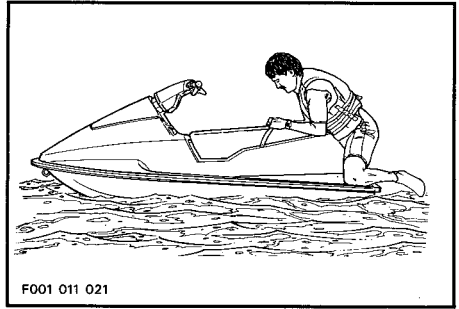

Bring your feet on the floorboard while maintaining balance using the handlebar.

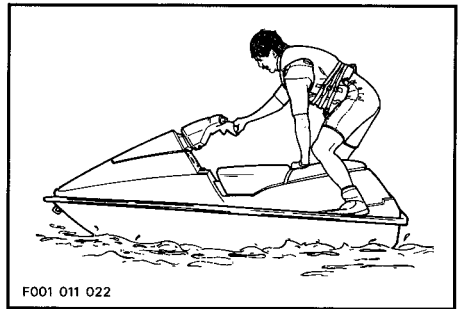
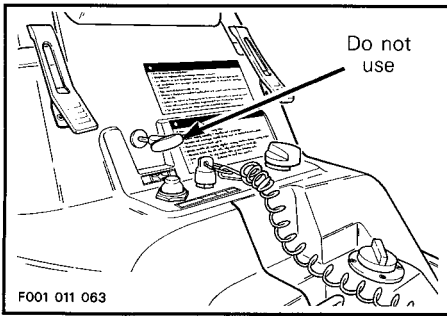

### Starting in Deep Water

#### operator Alone

Swim to the rear of the watercraft.

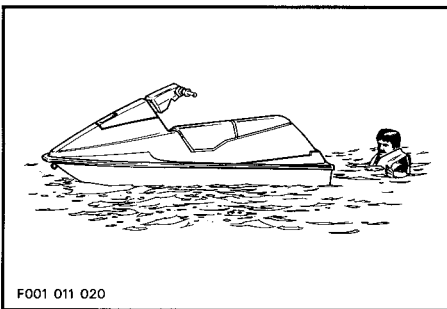

Sit astride the seat.

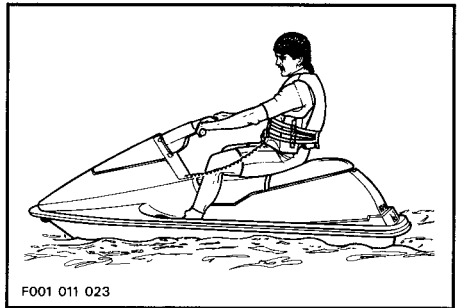

Grip the seat strap and pull yourself upward until your knee can reach the boarding pad.

Attach the tether cord to the operator's lifejacket and snap the cap to the switch before starting the engine.

Start the engine.



## Operator with a Passenger

The operator climbs on the watercraft the same way as explained previously.

In choppy water, the passenger while in the water, may maintain the watercraft's balance to help the operator while climbing aboard.

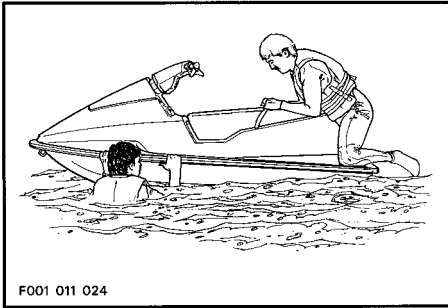

F001 011 024

Attach the tether cord to the operator's lifejacket and the snap cap to the switch before starting the engine.

The passenger then climbs on the watercraft while the operator maintains the balance.

◆ **WARNING** : Do not start engine until the passenger is properly seated.

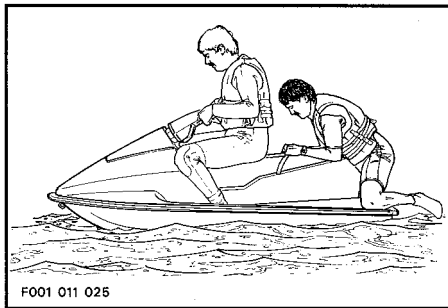

F001 011 025

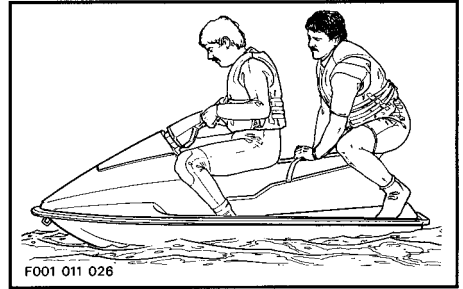

F001 011 026

## Rough Water Operation

Avoid riding in rough water and/or adverse weather conditions.

Always assist the rider(s) of a capsized boat then attempt to retrieve vessel using a tow rope.

It is not recommended to operate the watercraft within or around the surf-line.

If the watercraft is operated on rough water, the engine may have a misfiring sound. This is caused by a speed limiter which is intended to prevent the unloaded engine from exceeding a predefined RPM.

◆ **WARNING** : Wave jumping is not recommended.

## Docking

The watercraft is slowed by water drag. The stopping distance will vary depending on the watercraft mass, carrying weight, water surface condition, presence and direction of wind and current.



The operator should experiment to familiarize himself with the stopping distance under different conditions.

Ensure no craft, swimmer, underwater, near-surface obstacles are nearby.

Release the throttle a sufficient distance before the expected landing area thus having the water resistance slowing the watercraft. Remembering no directional control is available with the throttle closed.

Do not stop engine until the watercraft is completely stopped (except when beaching).

Reduce speed when approaching a dock then stop the engine just before coming alongside.

**WARNING :** No directional control is available when the throttle is closed or engine is stopped.

## Beaching

**CAUTION :** It is not recommended to run the watercraft to the beach.

Proceed the same way as for docking except for the following :

Come slowly to the beach and stop the engine when reaching about 60 cm (2 ft) of water under the hull.

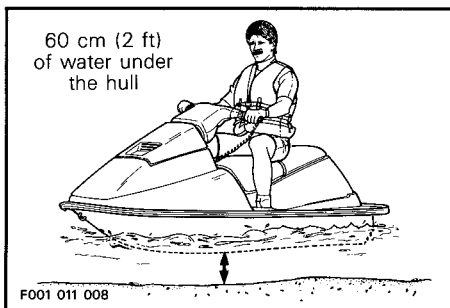

**CAUTION :** The engine must be stopped before less than 60 cm (2 ft) of water be underneath the hull. Otherwise shells, sand, pebbles or other objects could be drawn up by the jet pump and damage impeller, components or clog cooling system as well as jamming.

Get off watercraft and pull it on the beach.

As necessary, cooling system should be flushed before re-starting, to remove sand or shells accumulation which eventually might clog the water passages.

---

## Stopping the Engine

To keep watercraft directional control, the engine should be running until the watercraft is stopped assuming at least 60 cm (2 ft) of water be present underneath the hull.

To stop the engine, completely release throttle lever and press the engine stop button and **HOLD** it until engine stops.

◆ **WARNING**: Should the engine be stopped, watercraft directional control will not be available.

Remove tether cord from watercraft.

◆ **WARNING**: Never leave the tether cord on an unattended watercraft.

# POST-OPERATION CARE

---

## General Care

should any water be present in the hull, remove the drain plug and lean the watercraft to the rear in order to allow water to flow out.

Wipe up any remaining liquid in the engine compartment (bilge, engine, battery, etc) with clean dry rags (this is particularly important in salt water use).

Remove the watercraft from the water every day to prevent marine organisms from sticking to the hull.

## Additional Care for Unclean Water or Salt Water

When the watercraft is operated in unclean water and particularly in salt water, additional care must be taken to protect, the watercraft and its components.

▼ **CAUTION** : Failure to perform proper care such as : vehicle rinsing, cooling system flushing and anti-corrosion treatment, when watercraft is used in salt water, will result in damage to the watercraft and its components.

## Cooling system Flushing

Since the watercraft uses the same water where it sails, for propulsion and cooling systems, this water flows everywhere in water jackets. If the watercraft is being used in salt water and cooling system is not regularly flushed, salt will eventually corrode components.

Infiltration in cooling system of any particle present in the water is unavoidable. Deposits accumulation can clog cooling system and lead engine to severe damage.

A convenient flush kit (P/N 295 000 038) can permanently be installed on the watercraft to ease flushing. Refer to an authorized dealer for additional information concerning installation.

The flush kit must be used when the watercraft is operated in :

- salt water
- unclean water
- shallow water where underwater ground is sandy and/or shells covered.

Flushing the cooling system **with fresh water** is essential to neutralize corroding effects of salt or other chemical products present in water. It will help to evacuate sand, salt, shells or other particles in water jackets (engine, exhaust manifold, tuned pipe) and/or hoses.

Flushing should be performed when the watercraft is not expected to be used further the same day or when the watercraft is stored for any extended time.

▼ **CAUTION** : Failure to flush cooling system, when necessary, will severely damage engine and/or exhaust system.

◆ **WARNING** : Do not touch any electrical part when engine is running.

▼ **CAUTION** : Never flush a hot engine. Make sure engine operates during entire procedure.

Proceed as follows :

- 1- Remove seat to allow access of cooling system.
- 2- Connect coupler hose as explained in the flush kit instruction sheet. **Do not open the water tap yet.**

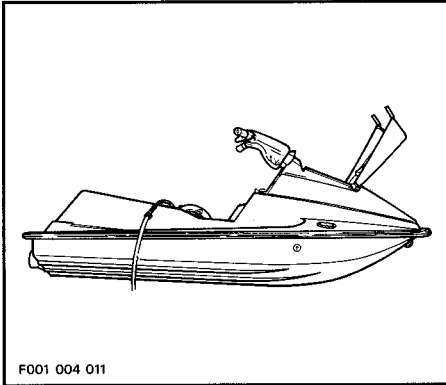

○ **NOTE :** To allow a more efficient flushing on watercraft equipped with a flush kit, install a hose pincer (P/N 295 000 076) between T-fitting and exhaust socket. This will prevent water exiting through exhaust socket.

- 3- Start the engine **then** immediately open the water tap.

▼ **CAUTION :** Always start the engine before opening the water tap. Otherwise, water will back flow through the tuned pipe into the engine and may cause damage to internal parts. Open water tap immediately after engine is started to prevent overheating. Follow this strict order.

- 4- Run the engine about 5 minutes at a fast idle.

- 5- Close the water tap **then** stop the engine.

▼ **CAUTION :** Always close the water tap before stopping the engine. Follow this strict order otherwise severe engine damage could occur.

- 6- Disconnect coupler hose from watercraft.

- 7- Wipe off any residual water on the engine.

- 8- Re-install seat and properly latch.

### **Anti-Corrosion Treatment**

To prevent corrosion, spray a corrosion inhibitor (salt water resistant) such as SEA-DOO LUBE (P/N 293 600 006) or the equivalent over all metallic components in engine compartment.

Apply a dielectric grease (P/N 293 550 004) or similar anti-corrosion product (salt water resistant) on battery posts and cable connectors.

▼ **CAUTION :** Never leave rags or tools in the engine compartment or in the bilge.

# SPECIAL PROCEDURES

## Engine Overheat

If the engine overheating beeper sounds, **stop engine immediately.**

Perform the "Jet Pump Water Intake and Impeller Cleaning" procedure.

Flush cooling system.

If engine still overheats, refer to an authorized dealer for servicing.

## Jet Pump Water Intake and Impeller Cleaning

Weeds, shells or debris can get caught on the intake grill, drive shaft and or impeller. A clogged water intake may cause troubles such as :

- 1- **Cavitation** : Engine speed is high but watercraft moves rather slowly due to reduced jet thrust, Jet pump components can be damaged.
- 2- **Overheating** : Since the jet pump operation controls the flow of water to cool the engine, a clogged intake might cause the engine to overheat and damage engine internal components.

The clogged area can be cleaned as follows :

**In-water cleaning** : Remove tether cord and rock the watercraft several times while repeatedly pressing starter button for short period. Most of the time, it gives satisfactory result letting the weeds fall from the intake area. Reinstall tether cord on switch, start engine and make sure water flows out from bleed outlet and watercraft operates properly.

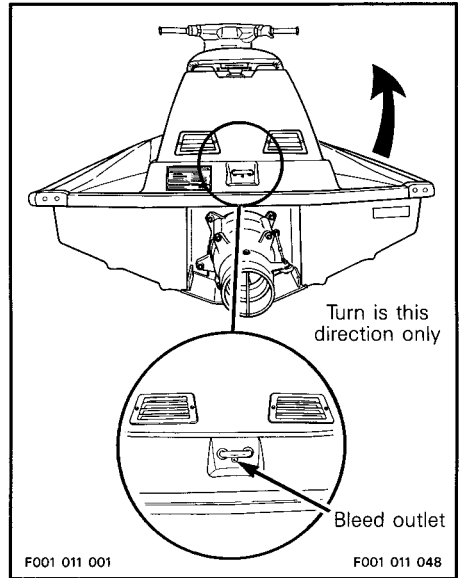

**On-beach cleaning** : Place a cardboard or a carpet beside the watercraft to prevent scratching when turning the watercraft for cleaning.

◆ **WARNING** : Always remove tether cord can from switch to prevent accidental engine starting before cleaning the jet pump area. Engine must not be running for this operation. Do not press starter button when cleaning pump intake area.

Rotate the watercraft **counter-clockwise** (seen from rear) to its left side for cleaning. Rotating watercraft clockwise could allow residual water in the tuned pipe to enter the engine and cause engine damage.

▼ **CAUTION** : Always turn the watercraft **counter-clockwise** (seen from rear). Otherwise cooling water could leak through the tuned pipe into the engine and cause engine damage.

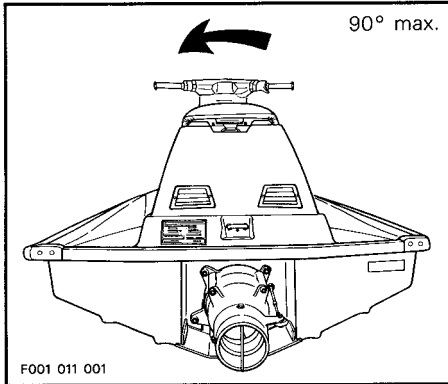

Clean the water intake area. If the system is still clogged, refer to an authorized dealer for servicing.

▼ **CAUTION** : Inspect water intake grill for damage. Refer to an authorized dealer for repair as necessary.

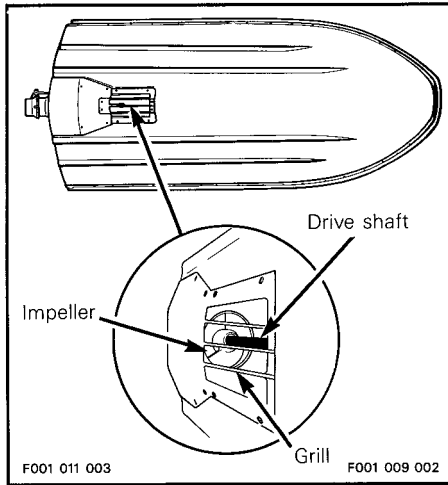

▼ **CAUTION** : Avoid watercraft operation in weeded areas. In the event it is unavoidable, vary watercraft speed. Weeds tend to entangle more at steady speed and at slow speed.

## Capsized Watercraft

The watercraft is designed so that if it is turned over, it should not remain capsized due to its self-righting capability.

▼ **CAUTION** : In the event engine is water-flooded, it must have proper treatment to prevent damage to engine internal parts. Refer to an authorized dealer immediately.

## Submerged Watercraft

This watercraft is designed so that even filled with water, it does not sink.

If the watercraft is submerged and engine is water-flooded, it is strongly recommended that the watercraft be serviced by an authorized dealer immediately.

▼ **CAUTION** : A water-flooded engine must have proper treatment to prevent damage to engine internal parts. Refer to an authorized dealer immediately.

## Towing the Watercraft

In the event the watercraft becomes inoperative, tie a tow-rope in the bow (front) eyelet and have the watercraft towed to the shore at moderate speed.

## Low-Charge Battery Condition

◆ **WARNING** : Do not boost the battery. Connecting jumping cables could produce a spark into the engine compartment and possibly cause an explosion if fuel or electrolyte vapors are present.

Following the recommended procedure in the "MAINTENANCE" section, remove the battery. Have it charged or replaced.

# MAINTENANCE

◆ **WARNING** : Only perform procedures as detailed in this manual. It is recommended that an authorized dealer assistance be periodically obtained on other components/systems not covered in this manual. Unless otherwise specified, engine must not be running and the tether cord must be removed for all maintenance procedures.

## Lubrication

### Flywheel and Seal Carrier Grease Fittings

Use SEA-DOO synthetic grease and lubricate once a month. Proceed as follows :

Remove seat to expose engine compartment.

◆ **WARNING** : Always remove tether cord cap from its receptacle to prevent accidental engine starting before removing the flywheel guard. Do not press starter button while working in this area.

Remove the retaining screws and pull flywheel guard.

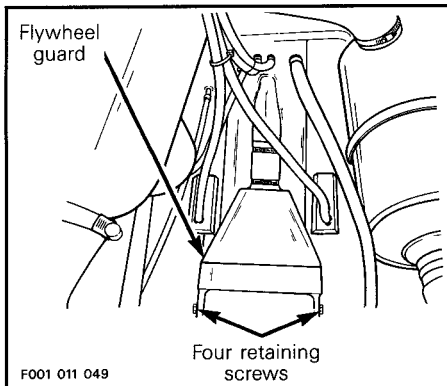

Using a grease gun, carefully lubricate at grease fitting until drive shaft boot is just beginning to expand.

▼ **CAUTION** : Immediately stop lubricating as soon as boot begins to expand to prevent boot damage or slipping.

Lubricate at seal carrier grease fitting until grease is just coming out on engine side.

▼ **CAUTION** : As soon as grease comes out the seal immediately stop lubricating to prevent seal damage and overheating

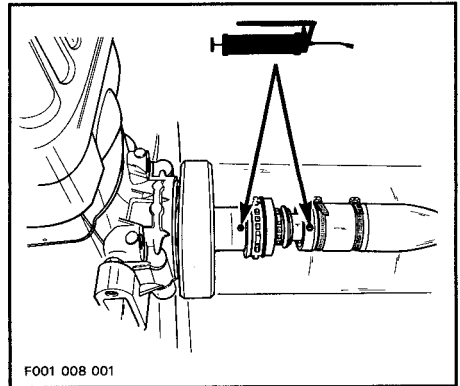

Secure flywheel guard.

## Anti-Corrosion Protection

### Throttle/Choke Cables

Lubricate the throttle and choke cables with SEA-DOO LUBE every three months.

○ **NOTE** : A cable luber can be used on cables end to power inject SEA-DOO LUBE into them. Refer to a motorcycle parts supplier for availability.

### Electrical Connections

As necessary, apply anti-corrosion product such as dielectric grease (PN 293 550 004) on battery posts and all exposed cable connectors.



## Additional lubrication

Proper lubricant such as LPS #3 or the equivalent, will help to prevent corrosion and keep proper operation of moving mechanisms.

Lubrication of the following items should be performed every six months in fresh water use but every month in salt water use.

### Choke Knob Lever

Fully pull choke knob and lubricate the metallic portion.

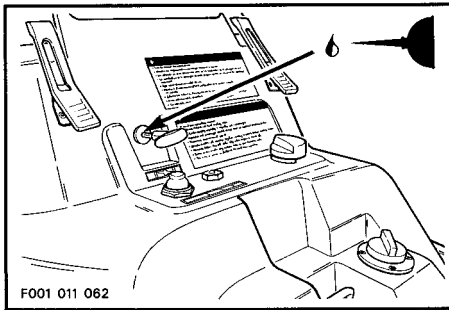

### Seat opening mechanism, tab and hooks

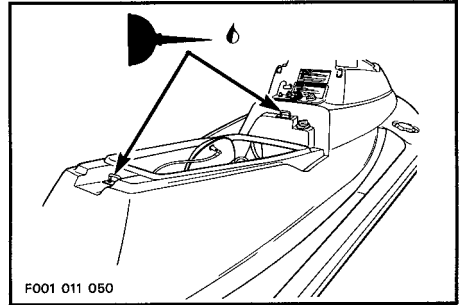
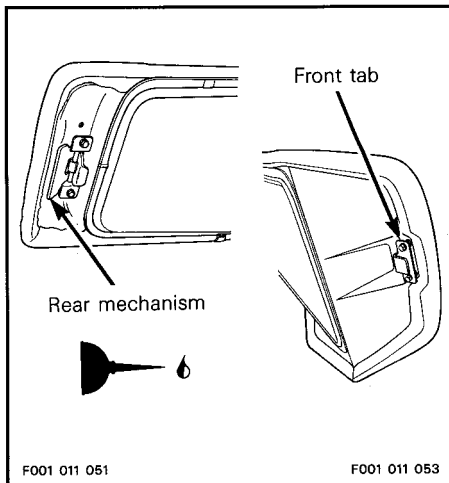

### Carburetor and Oil Injection Pump

Lubricate springs, shafts and exposed portion of cables.

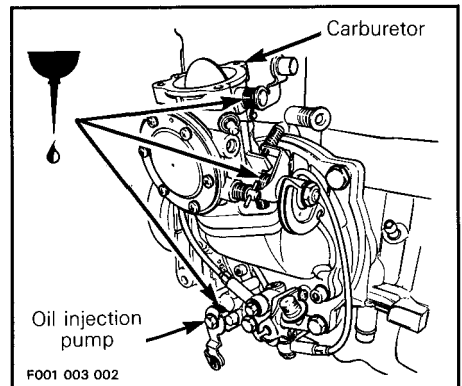

## Periodic Inspection

Routine maintenance is necessary for all mechanized products, and this watercraft is no exception. A periodic inspection contributes to the life span of the watercraft.

The following maintenance chart gives guidelines for regular servicing schedule to be performed by the operator or by an authorized dealer. The schedule can be adjusted according to operating conditions and use.

**IMPORTANT :** Schedule for watercraft rental operations may require greater frequency of inspection and maintenance.

## Periodic Inspection Chart

○ NOTE : Shaded area shows the maintenance frequency.

DESCRIPTION	FREQUENCY				To be performed by
	Monthly	3 Months	6 Months	Yearly	
Lubrication/corrosion protection	①				OPERATOR
Engine ignition timing					DEALER
Spark plugs, cleaning/adjustment					OPERATOR
Throttle/Choke cables, inspection/lubrication					OPERATOR
Flame arrester element, inspection					DEALER
Carburetor adjustment including choke/throttle cable adjustments					DEALER
Oil injection pump adjustment					DEALER
Fuel filter cleaning, oil filter inspection					OPERATOR
Oil filter, replacement					DEALER
Engine head screws, retorque					DEALER
Steering column wear/steering cable adjustment					DEALER
Fastener tightening (Flame arrester mount screws, carburetor mount nuts, engine mount screws, exhaust system, etc).					DEALER
Muffler, battery and reservoirs fastening devices					OPERATOR
Fuel/oil lines, check-valves and hoses inspection, fuel system pressurization					DEALER
Inspect/clean engine drain tube	①				DEALER
Bilge system/water-trap drains, inspection					OPERATOR
Battery condition					DEALER
Battery and starter cables					DEALER
Engine overheating beeper/electrical connections					DEALER
Impeller shaft reservoir oil level/oil condition				Replace	DEALER
Impeller condition and impeller/wear ring clearance		②			DEALER
Drive shaft boot condition (both ends)		②			DEALER
Drive shaft, lubricate grease fittings at flywheel					OPERATOR
Water intake grill condition		②			DEALER
Hull condition					DEALER
Cooling system flushing ③					OPERATOR

○ NOTE : Some items are included in the "DAILY PRE-OPERATION CHECKS" and are not necessarily repeated in this chart.

① Every month in salt water use.

② These items have to be initially checked after three months. Thereafter, servicing to be made as specified in this chart.

③ Daily flushing in salt water use.

## Spark Plug Cleaning and Adjustment

Spark plugs indicate the general engine condition and are easy to inspect. The tip condition of each spark plug should be checked for wear, cracks in porcelain, carbon or other deposits and color. A worn spark plug should be replaced by a new one. Abnormal deposits or tip color should be diagnosed by an authorized dealer.

◆ **WARNING :** High tension voltage is generated in the spark plug wires when engine is cranked or running. Never touch wires in such conditions.

Remove spark plugs and check condition.

The following gives guidelines about spark plug tip color :

- A brownish tip reflects ideal conditions.
  - Correct carburetor adjustments, spark plug heat range, etc.
- A black insulator tip indicates fouling, possibly caused by :
  - Carburetor idle speed mixture and/or high speed mixture too rich.
  - Incorrect oil pump adjustment (too rich).
  - Wrong spark plug type and/or heat range.
  - Excessive idling.
  - RPM limiter malfunction.
- A light grey insulator tip indicates a lean mixture, possibly caused by :
  - Carburetor high speed mixture too lean.
  - Wrong spark plug heat range.
  - Incorrect oil pump adjustment (too lean).
  - Leaking engine seal or gasket.

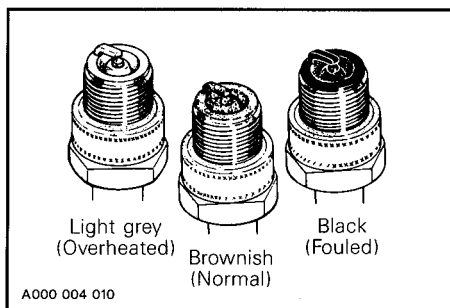

▼ **CAUTION :** If spark plug condition is not ideal, contact an authorized dealer.

○ **NOTE :** Refer to "SPECIFICATIONS" section for recommended spark plug number.

Clean spark plug and adjust gap to 0.6 mm (.024 in) using a wire feeler gauge.

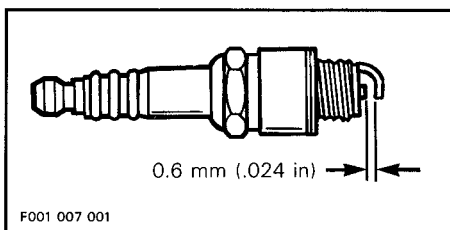

Reinstall spark plugs, properly tighten then reconnect wires.

▼ **CAUTION :** When installing or removing spark plugs, be careful not to damage the porcelain insulator.

## Throttle and Choke Cable Inspection

### Throttle Cable

Depress and release the throttle lever several times. It must operate smoothly and return to its initial position without any hesitation. Refer to an authorised dealer if necessary.

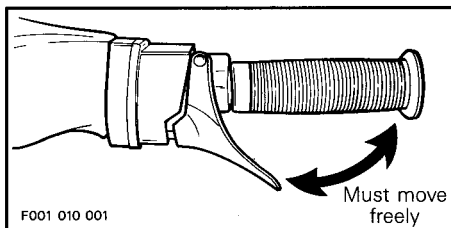

### Verification of Oil Injection Pump Alignment Marks

The throttle cable also activates the oil injection pump and therefore marks should be checked for alignment. Proper amount of oil delivered to the engine is critical. Any delay in the opening of the pump can result in serious engine damage.

Eliminate the throttle free-play by pressing the throttle lever until a slight resistance is felt then hold in place. The alignment marks on the pump body and lever must perfectly align. If not, do not attempt to adjust, contact an authorized dealer for adjustment.

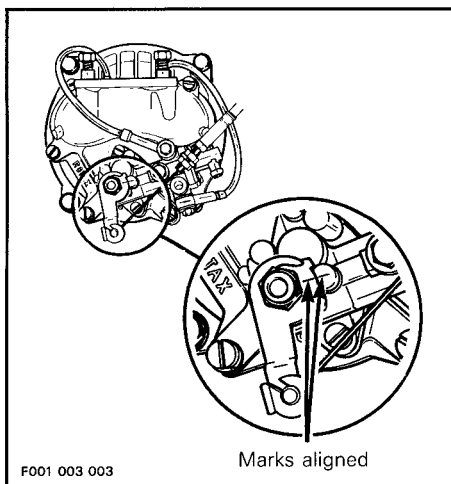

### Choke Cable Inspection

Ensure it operates smoothly and without any hesitation from fully open to fully close. When the choke knob is fully pulled, choke must be fully applied. Refer to an authorized dealer if necessary.

### Carburetor Adjustment

Carburetor adjustment is very important to allow good engine operation and therefore watercraft performance. Carburetor adjustments require technical knowledge and experience to have the correct mixture supplied to the engine. These critical adjustments must be performed by an authorized dealer once a year or more often if necessary.

▼ **CAUTION** : Serious engine damage can occur with improper carburetor adjustment.

### Fuel and Oil Filters

#### Fuel Filter

Turn the fuel valve to "OFF".

◆ **WARNING** : The engine must not be running and fuel valve must be set to "OFF". Gasoline is flammable and explosive under certain conditions. Always work in a well ventilated area. Do not smoke or allow open flames or sparks in the vicinity.

The fuel filter is located at the right hand side of the engine behind the air intake silencer. Therefore silencer has to be removed to access the fuel filter.

To remove the silencer, slacken the retaining clamp close to flame arrester cover and remove bolt from mounting bracket.

Pull silencer rearward to free from flame arrester cover then take it away.

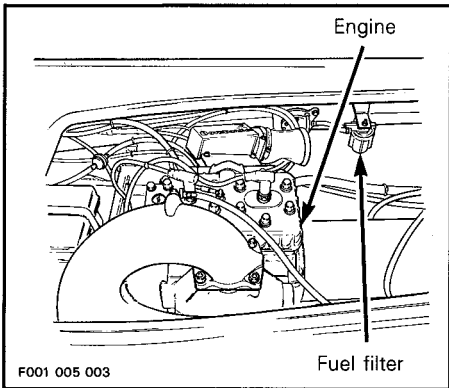
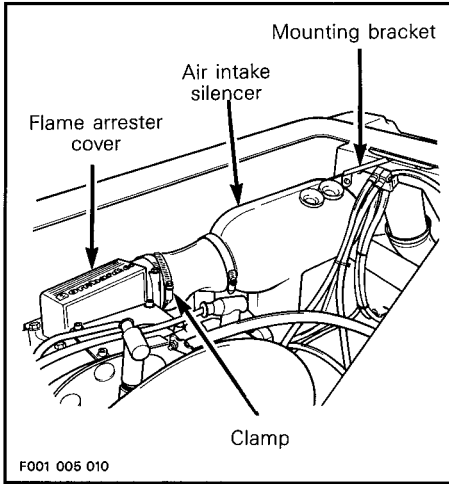

Before opening fuel filter, hold the bowl in a dry rag and proceed carefully to avoid gas spillage.

Unscrew the fuel filter bowl clockwise then pull toward the bottom.

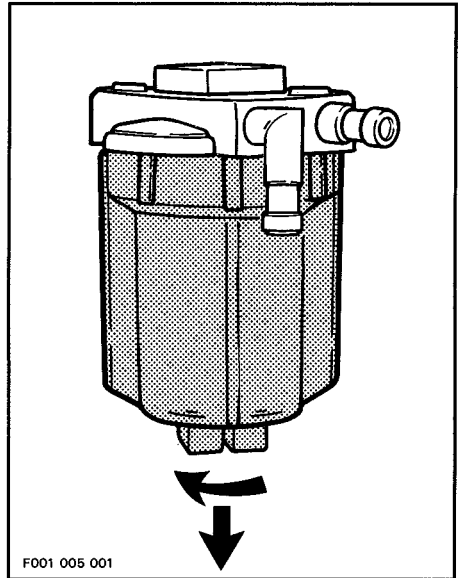

Pull the filter element toward the bottom.

Clean filter element and blow carefully with compressed air (low pressure) if available.

Be careful not to drop filter components in water or sand.

Replace filter element if permanently clogged or damaged.

Install the filter element first into the top portion.

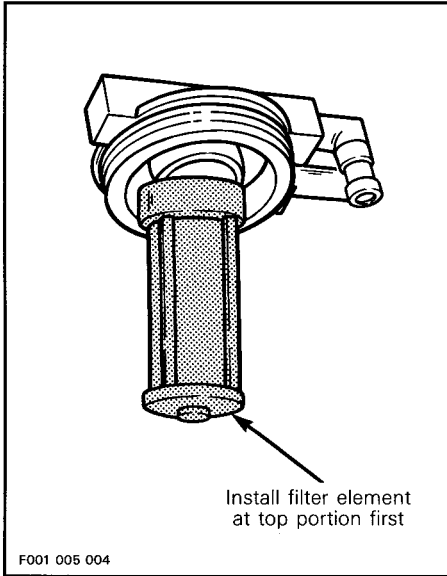

Inspect O-ring for damage, replace if necessary. Ensure the O-ring is well positioned into the filter bowl.

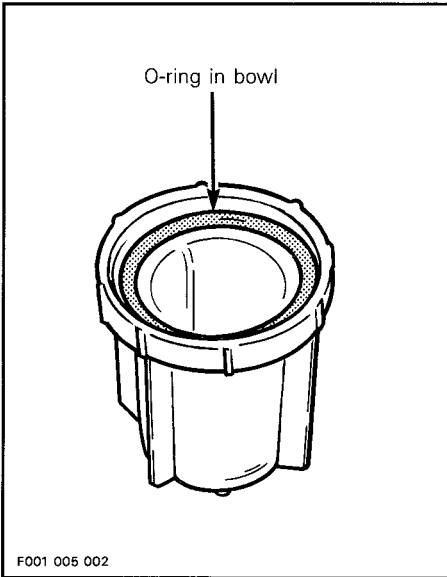

Install filter bowl and firmly hand tighten.

Temporarily turn the fuel valve to "ON" and check for leaks.

◆ **WARNING** : Ensure that there is no leakage from the fuel filter. Wipe off any spilled fuel.

○ **NOTE** : Should any water be found in the fuel tank, refer to an authorised dealer for servicing.

Return the fuel valve to "OFF".

### Oil Filter Inspection

The in-line oil filter is located close to the engine.

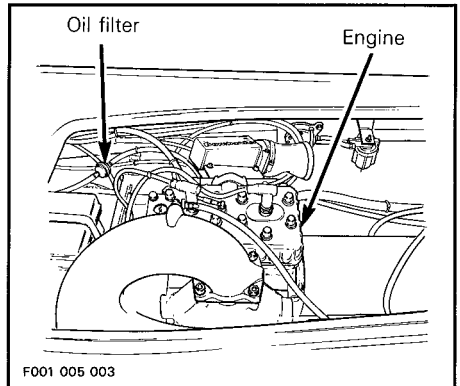

Visually inspect the oil filter at least once a month. Ensure that it is free of water, clean and no foreign particles are present, if so, refer to an authorized dealer for replacement.

▼ **CAUTION** : An obstructed injection oil filter will cause oil starvation resulting in serious engine damage.

## Steering/Jet Pump Nozzle Adjustment

When the handlebar is aimed in straight ahead position, the jet pump nozzle should be in the same direction to allow the watercraft running in straight line.

Refer to an authorized dealer if an adjustment is necessary.

◆ **WARNING:** Ensure the handlebar/jet pump nozzle operate freely from side to side and are not stressing, the steering cable.

Steering column wear should be inspected once a year by an authorised dealer.

## Bilge Draining Pick-Ups and Water-Trap Drains

### Bilge Draining Pick-Ups

They are located each side of the drive shaft tunnel.

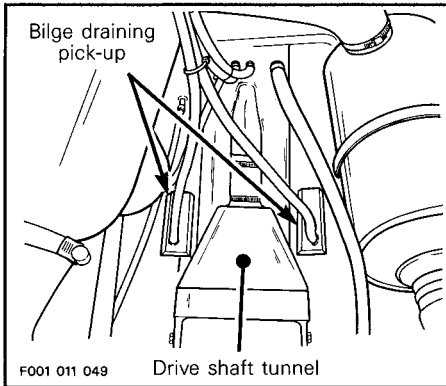

This watercraft features a vacuum activated syphon. Two pick-ups use a low pressure area in the jet pump to siphon the water out of the bilge.

Inspect each pick-up screen for obstructions, clean as necessary.

### Water-Trap Drains

Check for possible obstructions at drain outlets each side of the hull at the front.

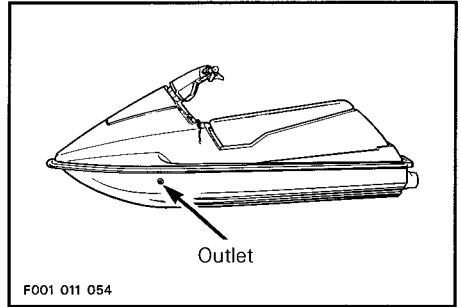

## Fuse Holder

Electrical system is protected with a fuse. If starter does not operate. Check fuse condition. The fuse holder is located in the electrical box over the battery.

To access fuse holder, remove cover retaining screws.

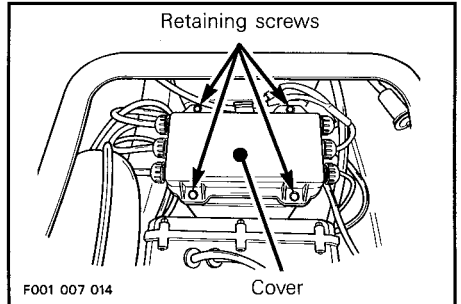

Pull cover and turn it upside down to find fuse holder.

Pull apart fuse holder to expose the fuse.

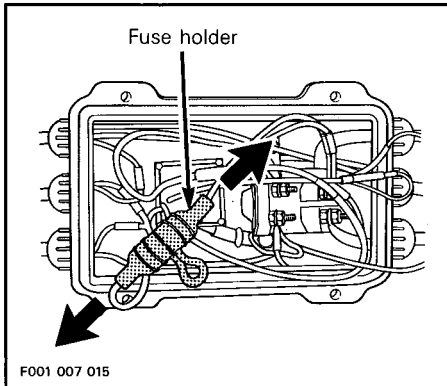

Replace the fuse by one of the same rating. Make sure to properly close the fuse holder.

○ **NOTE** : Refer to "SPECIFICATIONS" section for recommended fuse rating.

Wires in electrical box cover must hang freely. Do not pack wires in cover.

◆ **WARNING** : If any water is found in the electrical box, immediately refer to an authorized dealer before operating the watercraft.

Properly close electrical box making sure its seal is well positioned. Secure with the retaining screws. Do not over-tighten. Torque to 2 N•m (18 lbf•in).

## Battery

◆ **WARNING** : For any battery maintenance, the battery must be removed from the watercraft.

### Battery Removal

Proceed as follows :

1- Remove nuts from battery retaining studs.

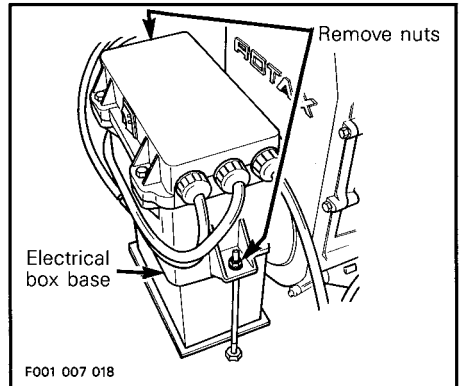

2- Remove electrical box ass'y from top of battery.

○ **NOTE** : Electrical box does not need to be opened for battery removal.

3- Disconnect the **black** negative cable **first**.

◆ **WARNING** : Always disconnect battery cables exactly in the specified order, black negative cable first. Electrolyte or fuel vapors can be present in the engine compartment and a spark might ignite them and possibly cause personal injuries.

4- Then disconnect the **red** cable last.

5- Remove the vent tube from the battery.

6- Remove battery from the watercraft being carefull not to have it leaned so that electrolyte can flow out of vent fitting.

▼ **CAUTION** : Should any electrolyte spillage occur, immediately wash off with a solution of baking soda and water to prevent damage to watercraft components.



◆ **WARNING** : Electrolyte is poisonous, dangerous and explosive. It contains sulfuric acid and can cause severe burns. Avoid contact with eyes, skin and clothing. Read and observe battery instructions found in other sections of this manual.

### Battery Maintenance

◆ **WARNING** : Battery must be kept in good condition. Without battery, the watercraft can not be started. Inspect battery electrolyte level regularly. Have its condition checked by an authorized dealer every three months.

Check electrolyte level when performing the "DAILY PRE-OPERATION CHECKS". It should be maintained at the HIGHEST level line of the battery casing.

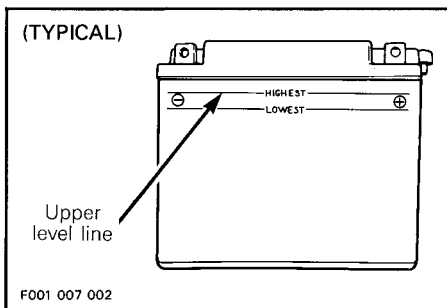

Add distilled water as necessary.

Battery posts and connections must be free of corrosion. If cleaning is necessary, remove corrosion with a stiff wire brush then clean with a solution of baking soda and water. Rinse with clear tap water and dry well.

▼ **CAUTION** : Do not allow cleaning solution to enter the battery. It will destroy the chemical properties of the electrolyte.

Fully charge the battery at a maximum rate of 2.0 Amperes.

◆ **WARNING** : Gases given off by a battery being charged are highly explosive. Always charge in a well ventilated area. Keep battery away from sparks, cigarettes or open flames. Avoid skin contact with electrolyte.

○ **NOTE** : If the battery is not to be used for a month or more, refer to "STORAGE" section for proper maintenance.

### Battery Installation

◆ **WARNING** : Always connect battery cables exactly in the specified order, red positive cable first black negative cable last.

Proceed as follows :

- 1- Install battery in its emplacement.
- 2- Secure vent tube to the battery. Ensure vent tube is not kinked or obstructed.
- ▼ **CAUTION** : Battery vent tube must be free, open and securely installed. If not, it will restrict ventilation and create gas accumulation that could result in an explosion. Avoid skin contact with electrolyte.
- 3- First connect red positive cable.
- 4- Then connect black negative cable last.
- 5- Apply anti-corrosion product (salt water resistant) such as dielectric grease (P/N 293 550 004) or the equivalent on battery posts.
- 6- Re-install the electrical box over the battery then properly tighten. Do not over tighten. Torque to 4 N•m (35 lbf•in).
- 7- Verify cables routing.

---

## General Inspection and Care

### Inspection

Check engine compartment for any damage and fuel/oil injection systems for leaks. Also check battery vent tube for electrolyte leaks. Ensure all hose clamps are properly secured and no hose is cracked, kinked or presenting any other damage.

◆ **WARNING : If any leak is found, do not start the engine and have the watercraft serviced by an authorized dealer. Failure to correct a leak could lead to an explosion.**

Inspect muffler, battery and reservoir fastening devices. Check electrical connections for corrosion and tightness.

Inspect hull and jet pump water intake grill for damage. Replace or have damaged parts repaired. It is recommended that an authorized dealer annually inspect the hull condition.

### Care

Twice a year, the bilge should be cleaned with hot water and detergent or bilge cleaner to remove any possible fuel/oil/electrolyte deposits.

Occasionally, wash the body with hot water and soap (only use mild detergent). Remove any marine organisms from engine and/or hull. Apply non-abrasive wax such as silicon wax. Protect the seat with vinyl protectant such as Armor All® or equivalent.

▼ **CAUTION : Never clean apparent fiberglass and plastic parts with strong detergent, degreasing agent, paint thinner, acetone etc.**

# TRANSPORTATION, STORAGE AND PRE-SEASON PREPARATION

◆ **WARNING :** Always turn the fuel valve to "OFF" when transporting or storing the watercraft.

## Transportation

Tie the watercraft to both bow and stern (front/rear) eyelets so that it is firmly retained on the trailer. Use additional cables if necessary.

▼ **CAUTION :** Do not route ropes or tie-downs over the seat as they could produce permanent damage. Wrap ropes or tie-downs with rags or similar protectors where they can touch the watercraft body.

Ensure seat is properly latched.

A SEA-DOO cover should protect the watercraft, particularly before driving on dirt roads, to prevent dirt entry through the air intake opening and clogging the water-trap drains.

Observe trailering safety precautions.

## Storage

It is during winter or when the watercraft is not to be in use for prolonged time that a proper storage is a necessity. Storage during long period of inactivity consists of checking and replacing missing, broken or worn parts and protecting cooling system against freezing (where applicable) and corrosion.

Proper lubrication and treatment should be performed to insure that parts do not become corroded and in general, preparing the watercraft so that when the time comes to use the watercraft again, it will be in top condition.

It is recommended that the watercraft be servicing by an authorized dealer for storage but the following operations can be performed by the operator with a minimum of tools.

## Engine Draining

Check engine drain tube running from engine water inlet socket to exhaust outlet socket. Make sure there is no sand or other particles and it is not obstructed so that water can leave the engine. Clean tube as necessary.

▼ **CAUTION :** Water in engine drain tube must be free to flow out, otherwise water could be trapped in engine. Should water freeze in engine, severe damage will occur.

▼ **CAUTION :** Check engine drain tube for obstructions.

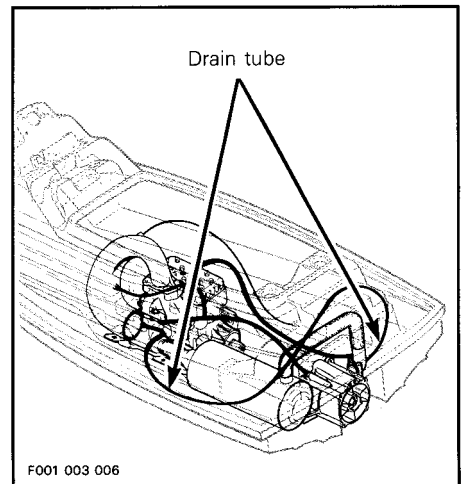

## Watercraft Rinsing

Thoroughly rinse the watercraft hull, bilge, engine compartment etc. with fresh water.

## Propulsion System

Lubricant in impeller shaft reservoir. Should be drained and reservoir cleaned refilled with (65 mL (2.2 U.S. oz) of SEA-DOO synthetic oil polyolester (P/N 293 600 011) 75W 90 GL5 type "C" gear lube. Refer to an authorized dealer for this operation.

▼ **CAUTION:** Use only SEA-DOO jet pump oil or equivalent synthetic gear oil, otherwise component service life could be reduced. Do not mix oil brands or types.

Lubricate drive shaft splines through grease fitting at flywheel end.

▼ **CAUTION:** Do not lubricate excessively. Immediately stop when a slight movement is noticed on rubber boot.

Lubricate at seal carrier grease fitting until grease is just coming out on engine side.

▼ **CAUTION:** As soon as grease comes out the seal immediately stop lubricating to prevent seal damage and overheating.

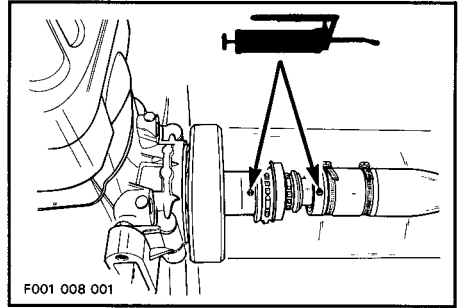

## Cooling System Flushing and Engine Internal Lubrication

Cooling system has to be flushed with fresh water to prevent salt, sand or dirt accumulation which might clog water passages. This will be achieved with the flush kit P/N 295 000 038.

Engine must be lubricated to prevent corrosion on internal parts. This will be achieved by spraying some SEA-DOO LUBE P/N 293 600 006 through air intake opening after removal of air intake silencer.

Flushing and lubrication will be done at the same time while engine is running.

### Procedure

Properly connect flush kit coupler hose to engine outlet hose.

○ **NOTE:** To allow a more efficient flushing on watercraft equipped with a flush kit, install a hose pincer (P/N 295 000 076) between T-fitting and exhaust socket. This prevent water exiting through exhaust socket.

Attach other end of flush kit coupler hose to a garden hose.

---

**▼ CAUTION :** Never flush a hot engine. Always start engine first then start water flow. Severe engine damage could result if not done in this order.

Start engine then start water flow. Make sure engine operates during entire procedure.

**◆ WARNING :** Do not touch any electrical part when engine is running.

Spray some SEA-DOO LUBE through air intake opening, keeping engine at a fast idle. Lubrication of engine should be done at least for one minute. After approximately half a minute, close fuel tank valve to run engine out of gas while lubricating.

**▼ CAUTION :** When engine begins to run irregularly because of gas starvation, immediately stop water flow before engine dies. Severe engine damage could result if not done in this order.

**◆ WARNING :** Perform this operation in a well ventilated area.

Press unlocking button to remove coupler hose. Re-install dust cap over T-fitting.

Remove both spark plugs and spray some SEA-DOO LUBE into each cylinder.

Crank the engine a few turns to distribute the oil on cylinder wall.

Apply anti-seize lubricant on spark plug threads then re-install them.

Re-install air intake silencer.

**▼ CAUTION :** Do not run the engine during the storage period.

### **Fuel System**

to prevent gum and varnish formation inside components, siphon all gas from fuel tank.

**◆ WARNING :** Remove fuel tank cap slowly. Fuel may be under pressure and might spray out when removing cap. Gasoline is flammable and explosive under certain conditions. Always work in a well ventilated area. Do not smoke or allow open flames or sparks in the vicinity. Always wipe off any fuel spillage from the watercraft.

### **Battery**

Referring to the "MAINTENANCE" section under "Battery Removal" to remove and clean the battery. Apply some dielectric grease (P/N 293 550 004) or petroleum jelly on battery posts and all exposed cable connectors.

Add distilled water if necessary then give the battery a full charge at a maximum rate of two Amperes.

Store the battery on a shelf in a warm dry place away from direct sunlight.

To prevent battery sulphating and discharging, have it charged every month.

### **Anti-Corrosion Treatment**

Wipe off any residual water in the engine compartment.

Spray some SEA-DOO LUBE over all metallic components in engine compartment.

## Additional Recommended Protection

Cooling system may be filled with a 50/50 water/antifreeze solution.

**CAUTION:** Always use ethylene-alcohol antifreeze containing corrosion inhibitors specifically recommended for aluminum engines.

**NOTE:** The engine will not have to run during this operation.

Four hoses have to be disconnected to allow air to escape and antifreeze solution to completely fill cooling system water jackets.

Disconnect the hoses where shown.

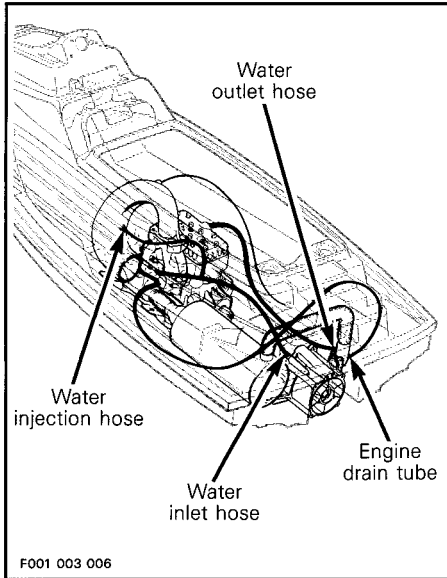

Raise all hoses above the highest point of tuned pipe and temporarily tie them together.

Insert a funnel into inlet hose going to the water inlet socket at engine. Pour about 2 liters (1/2 gal) of antifreeze solution through the funnel.

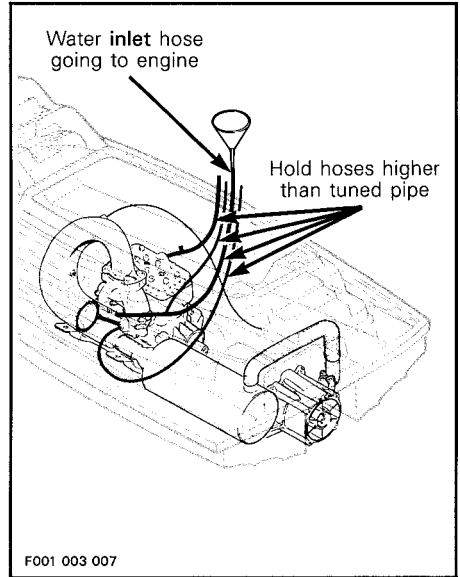

The following steps should be performed to provide the watercraft enhanced protection.

Remove muffler and drain out as much water as possible. Re-install muffler.

**OR:** Disconnect one hose from muffler and pour some antifreeze liquid inside muffler. Re-connect hose.

Lubricate the throttle cable with SEA-DOO LUBE.

**NOTE:** A cable luber can be used on throttle cable end to power inject SEA-DOO LUBE into cable. Refer to a motorcycle parts supplier for availability.

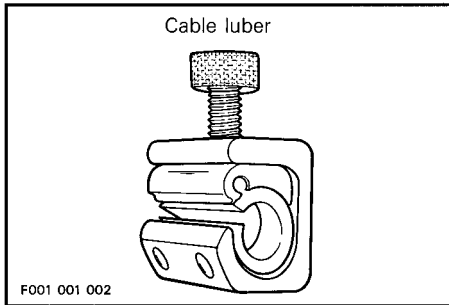

Clean the bilge with hot water and detergent or with bilge cleaner. Rinse thoroughly.

Wash the body with soap and water solution (only use mild detergent). Rinse thoroughly with fresh water. Remove marine organisms from the hull. Apply a non-abrasive wax such as silicon wax. Protect the seat with vinyl protectant such as Armor All® or the equivalent.

▼ **CAUTION** : Never clean apparent fiberglass and plastic parts with strong detergent, degreasing agent, paint thinner, acetone ect.

If the watercraft is to be stored outside, cover it with an opaque tarpaulin to prevent sun rays and grime from affecting the plastic components, watercraft finish as well as preventing dust accumulation.

▼ **CAUTION** : The watercraft must never be left in water for storage.

### **Pre-season Preparation**

Here is a suggested chart to follow. Notice that some operation should be performed by an authorized dealer as technical skills and special tools are required.

◆ **WARNING** : Observe all Warnings and Cautions mentioned throughout this manual which are pertinent to the item being checked. When component conditions seem less than satisfactory, replace with genuine BOMBARDIER parts or approved equivalents.

## Pre-Season Preparation Chart



OPERATIONS	To be performed by
Lubrication/corrosion protection	OPERATOR
Battery condition/charging and reinstallation	OPERATOR
Battery, starter connections and routing	DEALER
Spark plugs replacement (new ones) <sup>①</sup>	OPERATOR
Impeller shaft reservoir oil inspection	DEALER
Propulsion system inspection	DEALER
New oil filter installation and bleeding	DEALER
Oil injection tank filling	OPERATOR
Flame arrester cleaning/inspection	DEALER
Fuel filter cleaning	OPERATOR
Fuel line condition	DEALER
Filler neck condition	DEALER
Throttle/choke cables inspection/adjustment	DEALER
Oil injection pump adjustment	DEALER
Engine ignition timing	DEALER
Carburetor adjustment	DEALER
Steering column play/steering cable adjustment	DEALER
Water-trap drains/bilge lines/pick-ups inspection (animals nest)	CONCESSIONNAIRE
Cooling system inlet/outlet hoses (animals nest) engine overheat beeper	DEALER
General inspection (hull, check valves, leaks, fasteners, attachments)	DEALER
Fire extinguisher condition/mounting	OPERATOR

① Before installing new spark plugs, it is suggested to burn the excess SEA-DOO LUBE by starting the engine using the old spark plugs.



**◆ WARNING :** Only perform this operation in a well ventilated area. Flush kit (P/N 295 000 038) must be installed or watercraft must be in water to cool engine.

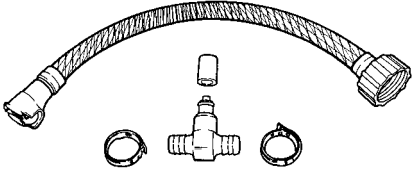
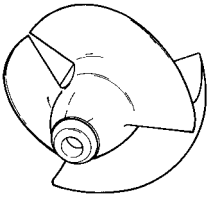

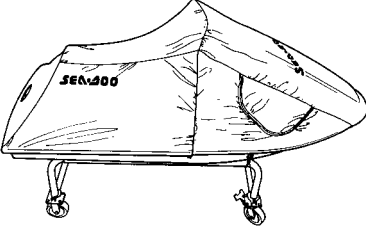
# ACCESSORY AND SERVICE PRODUCTS

ACCESSORY	PART NUMBER
<p data-bbox="88 232 194 256">Flush Kit</p>  <p data-bbox="88 492 184 508">F001 004 001</p>	<p data-bbox="668 354 891 378">P/N 295 000 038</p>
<p data-bbox="88 532 364 557">Stainless Steel Impeller</p>  <p data-bbox="88 800 184 816">F001 001 022</p>	<p data-bbox="668 654 891 678">P/N 271 000 046</p>
<p data-bbox="88 833 231 857">Extinguisher</p>  <p data-bbox="88 1101 184 1117">F001 001 023</p>	<p data-bbox="668 963 891 987">P/N 298 755 000</p>
<p data-bbox="88 1133 269 1157">Sea-Doo Cover</p>  <p data-bbox="88 1401 184 1417">F001 001 024</p>	<p data-bbox="668 1263 891 1287">P/N 298 305 080</p>

ACCESSORY	PART NUMBER
Mirror (Not Illustrated)	P/N 298 700 001
Sea-Doo Cleaner (Not Illustrated)	P/N 298 850 000
Tie-Down (Short) (Not Illustrated)	P/N 298 752 010
Tie-Down (Ratchet) (Not Illustrated)	P/N 298 753 010

SERVICE PRODUCTS	PART NUMBER
<p data-bbox="64 524 338 553">Jet Pump Synthetic Oil</p>  <p data-bbox="64 789 160 807">F001 001 025</p>	<p data-bbox="644 647 862 675">P/N 293 600 011</p>
<p data-bbox="64 828 203 857">Spray Paint</p>  <p data-bbox="64 1092 160 1110">F001 001 026</p>	<p data-bbox="602 932 910 961">Yellow P/N 293 500 008</p> <p data-bbox="626 967 910 997">Grey P/N 293 500 013</p>
<p data-bbox="64 1130 280 1159">Gelcote Repair Kit</p>  <p data-bbox="64 1391 160 1409">F001 001 027</p>	<p data-bbox="644 1252 868 1279">P/N 295 500 003</p>

SERVICE PRODUCTS	PART NUMBER
Lubricant Spray (Sea-Doo Lube) <div data-bbox="248 282 330 496" style="text-align: center;"> </div> <div data-bbox="78 493 174 509"> <p>F001 001 028</p> </div>	<p>P/N 293 600 006</p>
Injection Oil (Not Illustrated) 1 liter 4 liter	<p>P/N 293 600 005            P/N 293 600 004</p>
Grease "Dielectric" (Not Illustrated)	<p>P/N 293 550 004</p>

# TROUBLESHOOTING

The following chart is provided to help in diagnosing the probable source of simple troubles. Many problems can be quickly solved by the operator but other complicated ones required skilled mechanical technicians. In such cases, refer to an authorized dealer for servicing.

## ENGINE WILL NOT START

OTHER OBSERVATION	POSSIBLE CAUSE	REMEDY
Engine does not turn over	<ul style="list-style-type: none"> <li>• Fuse burnt out</li> <li>• Battery discharged</li> <li>• Battery connections, corroded/loose</li> </ul>	Check wiring then replace fuse. Charge / replace. Clean and tighten.
Engine slowly turns	<ul style="list-style-type: none"> <li>• Discharged or wear battery</li> </ul>	Charge / replace (have it checked).
Engine turns over	<ul style="list-style-type: none"> <li>• Tether cord removed</li> <li>• Fuel tank, empty or water-contaminated</li> <li>• Fuel filter, clogged or water-contaminated</li> <li>• Flooded engine :               <ul style="list-style-type: none"> <li>— Fouled / defective spark plugs</li> <li>— Misure of choke</li> </ul> </li> </ul>	Install cap over switch. Refill. Siphon & fill with fresh gas.  Clean, check fuel tank for water.  Replace  Use only with cold engine. Clean/replace spark plugs.

## ENGINE MISFIRES, RUNS IRREGULARLY

OTHER OBSERVATION	POSSIBLE CAUSE	REMEDY
Weak spark	<ul style="list-style-type: none"> <li>• Fouled / defective / worn spark plugs</li> <li>• Faulty RPM limiter</li> <li>• Too much oil supplied to engine</li> </ul>	Clean / verify spark plug and heat range. Replace as required. Refer to an authorized dealer. Improper oil pump adjustment, refer to an authorized dealer.
Lean fuel mixture	<ul style="list-style-type: none"> <li>• Fuel : Level too low, stale or water-contaminated</li> <li>• Fuel filter, clogged or water-contaminated</li> </ul>	Siphon and/or refill. Clean, check fuel tank for water.
Rich fuel mixture (high fuel consumption)	<ul style="list-style-type: none"> <li>• Flame arrester dirty/clogged</li> </ul>	Clean or replace.

## ENGINE OVERHEATS

OTHER OBSERVATION	POSSIBLE CAUSE	REMEDY
Overheating beeper sounds	<ul style="list-style-type: none"> <li>• Clogged jet pump water intake</li> <li>• Incorrect type of gas or oil</li> <li>• Clogged coolant system</li> </ul>	Clean. Siphon and refill. Flush cooling system with flush kit.

---

**ENGINE CONTINUALLY BACKFIRES**

OTHER OBSERVATION	POSSIBLE CAUSE	REMEDY
Weak spark	<ul style="list-style-type: none"><li>• Fouled / defective / worn spark plugs</li></ul>	Clean / verify spark plug and heat range. Replace as required.
Overheated engine	<ul style="list-style-type: none"><li>• See "ENGINE OVERHEATS"</li></ul>	

**ENGINE PINGING OR KNOCKING**

OTHER OBSERVATION	POSSIBLE CAUSE	REMEDY
	<ul style="list-style-type: none"><li>• Poor quality gasoline / low octane</li><li>• Spark plug heat range too high</li></ul>	Use well known quality and recommended gasoline. Use recommended spark plug number.

**ENGINE LACKS ACCELERATION OR POWER**

OTHER OBSERVATION	POSSIBLE CAUSE	REMEDY
	<ul style="list-style-type: none"><li>• Weak spark / incorrect fuel mixture</li><li>• Water in gas or injection oil</li></ul>	Refer to "ENGINE MISFIRES...". Siphon and replace.
Overheated engine	<ul style="list-style-type: none"><li>• See "ENGINE OVERHEATS"</li></ul>	

**ENGINE RUNS TOO FAST**

OTHER OBSERVATION	POSSIBLE CAUSE	REMEDY
Watercraft can not reach top speed	<ul style="list-style-type: none"><li>• Cavitation, jet pump water intake clogged</li></ul>	Clean.

**ABNORMAL NOISE FROM PROPULSION SYSTEM**

OTHER OBSERVATION	POSSIBLE CAUSE	REMEDY
	<ul style="list-style-type: none"><li>• Weeds or debris jammed around impeller</li></ul>	Clean and check for damage.

# SPECIFICATIONS

<b>ENGINE</b>		
Engine Type		Rotax 2-stroke, type 587
Induction Type		Rotary valve
Exhaust System		Water cooled / water injected
Lubrication	Type	Oil injection
	Oil type	SEA-DOO INJECTION OIL
Number of Cylinders		2
Bore		76.0 mm (2.992 in)
Stroke		64.0 mm (2.520 in)
Displacement		580.7 cm <sup>3</sup> (35.43 in <sup>3</sup> )
Compression Ratio (Corrected)		5.9:1
Maximum Power (approximately)		37 kW (50 HP) @ 5750 RPM
Maximum Torque (approximately)		67 N•m (49 lbf•ft) @ 5500 RPM
RPM Limiter Operation @		6500 RPM ± 200
<b>COOLING</b>		
Type		Water cooled, total loss type. Direct flow from propulsion unit.
Overheating Beeper, Switch On @		96-99°C (205-210°F)
<b>ELECTRICAL</b>		
Magneto Generator Output		160 W @ 5500 RPM
Ignition System Type		Capacitor Discharge Ignition (Breakerless)
Spark Plug	Make and Type	Champion, RN4C
	Gap	0.6 mm (.024 in)
Starting System		Electric starter
Ignition Timing	BTDC	2.18 mm (.086 in) (19° ± 2°)
	Note	Checked with engine cold. Marks must align @ 6000 RPM
Battery		12 V, 20 A
Starting System Fuse		8 A
<b>CARBURATION</b>		
Gas Type		Regular unleaded
Carburetor	Type and Number	Diaphragm type BN-38-34-45
Carburetor Adjustment	Low-speed Mixture Screw	~ 1-1/2 - 2 turns
	Idle Speed	1200 RPM

<b>PROPULSION</b>		
Système de propulsion		Turbine Formula de Bombardier
Type de turbine		Débit axial, monophasé
Sens de rotation de l'hélice (vue de l'arrière)		Anti-horaire
Transmission		Prise directe
Type d'accouplement		Cannelures en couronne
Type d'huile du réservoir de l'arbre d'hélice		Huile synthétique Sea-Doo "poly lester" pour engrenages 75W90GL5 de type "C"
Angle de pivot de direction (tuyère)		~ 28°
Niveau d'eau minimum requis pour la turbine		60 cm (2 pi)
Diamètre de la turbine		139.5 mm (5.49 po)
<b>PERFORMANCE</b>		
Autonomie de conduite avec l'accélérateur à fond	Réservoir à essence sans la réserve	~ 2 heures
	Réserve du réservoir à essence	~ 30 minutes
Vitesse maximale <sup>①</sup>		64 Km/h (40 mph) (35 noeuds)
<b>DIMENSIONS</b>		
Nombre de passagers		1 conducteur et 1 passager
Longueur hors-tout		244 cm (96 po)
Largeur hors-tout		105 cm (41.5 po)
Hauteur hors-tout		92 cm (36.2 po)
Masse		166 kg (365 lb)
Limite de charge		160 kg (352 lb)
Matériau de la coque		Composite (fibre de verre)
<b>CONTENANCES</b>		
Réservoir à essence		29.1 L (7.7 gal É.-U.)
Réservoir de l'arbre d'hélice	Capacité	65 mL (2.2 oz É.-U.)
	Niveau d'huile	Au bouchon inférieur
Réservoir d'huile à injection		2.8 L (95 oz liquides É.-U.)

① La vitesse maximale peut varier selon le poids du conducteur et du passager, des conditions de l'eau, du vent, du courant, de l'altitude, etc.

BOMBARDIER INC. se réserve le droit d'effectuer des changements dans le design et les caractéristiques de ses véhicules, et/ou d'y effectuer des apports ou des améliorations, cela sans s'engager d'aucune façon à effectuer les dites opérations sur les véhicules déjà fabriqués.

# SI\* METRIC INFORMATION GUIDE

BASE UNITS			
DESCRIPTION	UNIT	SYMBOL	
length	meter	m	
mass	kilogram	kg	
force	Newton	N	
liquid	liter	L	
temperature	Celsius	°C	
pressure	kilopascal	kPa	
torque	Newton meter	N•m	
land velocity	kilometer per hour	km/h	
navigation velocity	knot	kn	

PREFIXES			
PREFIX	SYMBOL	MEANING	VALUE
kilo	k	one thousand	1000
centi	c	one hundredth of	0.01
milli	m	one thousandth of	0.001
micro	μ	one millionth of	0.000001

CONVERSION FACTORS			
TO CONVERT	TO <sup>⊙</sup>	MULTIPLY BY	
in	mm	25.4	
in	cm	2.54	
in <sup>2</sup>	cm <sup>2</sup>	6.45	
in <sup>3</sup>	cm <sup>3</sup>	16.39	
ft	m	0.3	
oz	g	28.35	
lb	kg	0.45	
lbf	N	4.4	
<b>lbf•in</b>	<b>N•m</b>	0.11	
<b>lbf•ft</b>	<b>N•m</b>	1.36	
<b>lbf•ft</b>	<b>lbf•in</b>	12	
PSI	kPa	6.89	
imp. oz	U.S. oz	0.96	
imp. oz	mL	28.41	
imp. gal	U.S. gal	1.2	
imp. gal	L	4.55	
U.S. oz	mL	29.57	
U.S. gal	L	3.79	
knot	MPH	1.15	
MPH	km/h	1.61	
Fahrenheit	Celsius	$(^{\circ}\text{F} - 32) \div 1.8$	
Celsius	Fahrenheit	$(^{\circ}\text{C} \times 1.8) + 32$	

\*The international system of units abbreviates "SI" in all languages.

<sup>⊙</sup> To obtain the reverse sequence, divide by the given factor. To convert "millimeters" to "inches", divide by 25.4.