



# 2004 OPERATOR'S MANUAL

2101506

# OPERATOR'S MANUAL 2004

6900 FCE

GLX 5900 FCE

ST 550 F/600

Forest Fox Syncro

Rave 800 HO/RC

Racing

Ranger Mountain 800 HO

Sport Touring 800 SDI/600 HO

Ranger 600 LC/550 F

Explorer 550 F

Safari 400 F/Safartica

Ranger V-1000

59 Yeti

Enduro 600 HO/600 HO RC/500/500 RC

Enduro 550 RC/400 HO RC

# CONTENT

<b>SAFETY MEASURES .....</b>	<b>5</b>
------------------------------	----------

<b>WARRANTY .....</b>	<b>6</b>
-----------------------	----------

<b>HOW TO IDENTIFY YOUR SNOWMOBILE .....</b>	<b>9</b>
--	----------

Vehicle serial number .....	9
-----------------------------	---

Engine serial number .....	9
----------------------------	---

<b>CONTROLS/INSTRUMENTS .....</b>	<b>10</b>
-----------------------------------	-----------

1. Throttle lever .....	14
-------------------------	----

2. Brake lever .....	15
----------------------	----

3. Parking brake lever .....	15
------------------------------	----

4. Brake / parking brake / low oil level pilot lamp (Red) .....	16
---	----

5. Gear shift lever or RER button .....	16
---	----

6. Reverse indicator lamp .....	19
---------------------------------	----

7. Handle bar .....	20
---------------------	----

8. Holding strap .....	20
------------------------	----

9. Ignition switch/START/RER button .....	20
---	----

10. Tether cut-out switch .....	21
---------------------------------	----

11. DESS pilot lamp .....	23
---------------------------	----

12. Emergency cut-out switch .....	23
------------------------------------	----

13. Headlamp dimmer switch .....	24
----------------------------------	----

14. High beam pilot lamp (Blue) .....	25
---------------------------------------	----

15. Rewind starter handle .....	25
---------------------------------	----

16. Choke lever .....	26
-----------------------	----

17. Primer .....	26
------------------	----

18. Speedometer .....	26
-----------------------	----

19. Odometer .....	27
--------------------	----

20. Trip meter .....	27
----------------------	----

21. Trip meter reset button/mode button .....	27
---	----

22. Fuel tank cap/gauge .....	28
-------------------------------	----

23. Engine overheating warning lamp (Red) .....	29
---	----

24. Heated grip and throttle lever switch .....	29
---	----

25. Heated throttle lever switch .....	29
--	----

26. Hood latches .....	30
------------------------	----

27. Electric power outlet .....	30
---------------------------------	----

28. Fuse .....	30
----------------	----

29. Front bumper .....	32
------------------------	----

30. Storage compartment .....	33
-------------------------------	----

31. Rear rack .....	33
---------------------	----

32. Tool kit .....	33
--------------------	----

33. Spark plug holder .....	33
34. Seat strap .....	34
35. Hitch .....	34
36. Adjustable suspension .....	34
General .....	34
Guidelines .....	34
Suspension troubleshooting .....	42
In deep snow .....	42
<b>FUEL AND OIL .....</b>	<b>43</b>
Recommended fuel .....	43
Recommended oil .....	43
<b>COLD WEATHER CARBURATION MODIFICATIONS .....</b>	<b>44</b>
<b>BREAK-IN PERIOD .....</b>	<b>46</b>
Engine .....	46
Drive belt .....	46
10 hour inspection .....	46
<b>PRE-OPEARATION CHECK .....</b>	<b>46</b>
<b>CHECK LIST .....</b>	<b>46</b>
<b>OPERATION INSTRUCTIONS .....</b>	<b>47</b>
Operations .....	47
Starting the engine .....	47
Manual starting .....	47
Shutting off the engine .....	51
<b>VEHICLE WARM UP .....</b>	<b>52</b>
<b>POST-OPERATION CARE .....</b>	<b>52</b>
<b>SPECIAL OPERATIONS .....</b>	<b>52</b>
Riding at high altitudes .....	52
Engine overheating .....	52
Fuel flooded engine .....	53
Rear suspension slider shoe sticking .....	53

<b>FLUID LEVELS .....</b>	<b>53</b>
Brake system .....	53
Chaincase oil level/Gearbox oil level .....	54
Oil injection system .....	55
Cooling system .....	57
Battery .....	59
<b>MAINTENANCE .....</b>	<b>60</b>
Vehicle cleaning and protection .....	60
Belt guard removal and installation .....	60
Drive belt removal and installation .....	60
Drive chain tension .....	67
TRA drive pulley adjustment .....	68
Drive belt condition .....	70
Brake condition .....	70
Brake adjustment .....	70
Rear suspension condition .....	70
Suspension stopper strap condition .....	71
Track condition .....	71
Track tension and alignment .....	71
Steering and front suspension mechanism .....	73
Wear and condition of skis and runners .....	73
Exhaust system .....	73
Air filter cleaning .....	74
Headlight .....	76
<b>STORAGE AND PRE-SEASON PREPARATION .....</b>	<b>78</b>
Storage .....	78
Pre-season preparation .....	78
<b>TROUBLESHOOTING .....</b>	<b>83</b>

## SAFETY MEASURES

- \* For vehicle with a parking brake always engage brake when snowmobile is not in use.
- \* Throttle mechanism should be checked for free movement before starting engine.
- \* The snowmobile can be stopped by activating the emergency cut-out switch, pulling the tether cord or turning off the ignition key (if equipped).
- \* Engine should be running only when belt guard is secured in place. Never run the engine without drive belt installed. Running an unloaded engine can prove to be dangerous.
- \* Never run the engine when the track is raised off the ground or with the hood opened or removed.
- \* Do not stud the track. At speed it may cause the track to tear and separate from vehicle posing a risk of severe injury or death.
- \* Never start the engine in closed area or indoors.
- \* Maintain your snowmobile in top mechanical condition at all times.
- \* Snowmobile is not designed to be operated on public streets, roads or highways. In most countries it is considered an illegal operation.
- \* Never charge or boost battery while installed on snowmobile.
- \* Do not lubricate throttle and/or brake cables and housings.

# **INTERNATIONAL BOMBARDIER LIMITED WARRANTY 2004 LYNX® SNOWMOBILES**

## **1. SCOPE OF THE LIMITED WARRANTY**

BOMBARDIER-NORDTRAC OY (hereinafter "BOMBARDIER") warrants its 2004 LYNX snowmobiles from defects in material or workmanship for the period described below.

All genuine BOMBARDIER parts and accessories, installed by an authorized BOMBARDIER distributor/dealer (as hereinafter defined) at the time of delivery of the 2004 LYNX snowmobile, carry the same warranty as that of the snowmobile.

Use of the product for racing or any other competitive activity, at any point, even by a prior owner will render this warranty null and void.

## **2. WARRANTY COVERAGE PERIOD**

This warranty will be in effect FROM THE DATE OF DELIVERY TO THE FIRST RETAIL CONSUMER or the date the product is first put into use, whichever occurs first and for a period of:

- A) TWELVE (12) CONSECUTIVE MONTHS, for private use owners
- B) TWELVE (12) CONSECUTIVE MONTHS, for commercial use owners
- C) TWENTY FOUR (24) CONSECUTIVE MONTHS, for private use owners

when product was sold in a member state of the European Unit.

The repair or replacement of parts or the performance of service under this warranty does not extend the life of this warranty beyond its original expiration date.

## **3. CONDITIONS TO HAVE WARRANTY COVERAGE**

This warranty coverage is available only on 2004 LYNX snowmobile purchased as new and unused by its first owner from a BOMBARDIER distributor/dealer authorized to distribute LYNX products in the country in which the sale occurred (hereinafter "BOMBARDIER distributor/ dealer"), and then only after the BOMBARDIER specified pre-delivery inspection process is completed and documented. Moreover, this warranty coverage is only available if the LYNX snowmobile is purchased in the country in which the purchaser resides. Bombardier will not honor this limited warranty to any personal use owner or commercial use owner where the preceding conditions have not been met. Warranty coverage only becomes available upon proper registration of the product by a BOMBARDIER dealer. Such limitations are necessary in order to allow BOMBARDIER to preserve both the safety of its products, and also that of its consumers and the public. Routine maintenance outlined in the Operator's Guide must be timely performed in order to maintain warranty coverage. BOMBARDIER reserves the right to make warranty coverage contingent upon proof of proper maintenance.

## **4. WHAT TO DO TO OBTAIN WARRANTY COVERAGE**

The customer must notify a servicing BOMBARDIER distributor/dealer within two (2) months of the appearance of a defect, and provide it with reasonable access to the product and

reasonable opportunity to repair it. The customer must also present to the BOMBARDIER dealer, proof of purchase of the product and must sign the repair/work order prior to the start of the repair in order to validate the warranty repair. All parts replaced under this limited warranty become the property of BOMBARDIER.

## **5. WHAT BOMBARDIER WILL DO**

BOMBARDIER's obligations under this warranty are limited to, at its sole discretion, repairing parts found defective under normal use, maintenance and service, or replacing such parts with new genuine BOMBARDIER parts without charge for parts and labor, at any authorized BOMBARDIER distributor/dealer.

BOMBARDIER reserves the right to improve or modify products from time to time without assuming any obligation to modify products previously manufactured.

## **6. EXCLUSIONS - ARE NOT WARRANTED**

Normal wear and tear;

- Routine maintenance items, tune ups, adjustments;
- Damage caused by failure to provide proper maintenance and/or storage, as described in the *Operator's Guide*;
- Damage resulting from removal of parts, improper repairs, service, maintenance, modifications or use of parts not manufactured or approved by BOMBARDIER or resulting from repairs done by a person that is not an authorized servicing BOMBARDIER dealer;
- Damage caused by abuse, abnormal use, neglect, use of the product on surfaces other than snow, or operation of the product in a manner inconsistent with the recommended operation described in the *Operator's Guide*;
- Damage resulting from accident, submersion, fire, theft, vandalism or any act of God;
- Operation with fuels, oils or lubricants which are not suitable for use with the product (see the *Operator's Guide*);
- Snow or water ingestion;
- Incidental or consequential damages, or damages of any kind including without limitation towing, storage, telephone, rental, taxi, inconvenience, insurance coverage, loan payments, loss of time, loss of income; and
- Damage resulting from tracks which have been studded.

## **7. LIMITATIONS OF LIABILITY**

THIS WARRANTY IS EXPRESSLY GIVEN AND ACCEPTED IN LIEU OF ANY AND ALL OTHER WARRANTIES, EXPRESSED OR IMPLIED, INCLUDING WITHOUT LIMITATION ANY WARRANTY OF MERCHANTABILITY OR FITNESS FOR A PARTICULAR PURPOSE. TO THE EXTENT THAT THEY CANNOT BE DISCLAIMED, THE IMPLIED WARRANTIES ARE LIMITED IN DURATION TO THE LIFE OF THE EXPRESS WARRANTY. INCIDENTAL AND CONSEQUENTIAL DAMAGES ARE EXCLUDED FROM COVERAGE UNDER THIS WARRANTY. SOME JURISDICTIONS DO NOT ALLOW FOR THE DISCLAIMERS, LIMITATIONS AND EXCLUSIONS IDENTIFIED ABOVE, AS A RESULT, THEY MAY NOT APPLY TO YOU. THIS WARRANTY GIVES YOU SPECIFIC RIGHTS, AND YOU MAY ALSO HAVE OTHER LEGAL RIGHTS WHICH MAY VARY FROM COUNTRY TO COUNTRY.



Neither the distributor, any BOMBARDIER dealer nor any other person has been authorized to make any affirmation, representation or warranty regarding the product, other than those contained in this limited warranty, and if made, shall not be enforceable against BOMBARDIER.

BOMBARDIER reserves the right to modify this warranty at any time, being understood that such modification will not alter the warranty conditions applicable to the products sold while this warranty is in effect.

## **8. TRANSFER**

If the ownership of a product is transferred during the warranty coverage period, this warranty shall also be transferred and be valid for the remaining coverage period provided that BOMBARDIER is notified of such transfer of ownership in the following way:

BOMBARDIER or an authorized BOMBARDIER LYNX distributor/dealer receives a proof that the former owner agreed to the transfer of ownership, in addition to the co-ordinates of the new owner. The distributor will then forward this information directly to Bombardier.

## **9. CONSUMER ASSISTANCE**

- In the event of a controversy or a dispute in connection with this BOMBARDIER LIMITED WARRANTY, BOMBARDIER suggests that you try to resolve the issue at the dealership level. We recommend discussing the issue with the authorized dealer's service manager or owner.
- If further assistance is required, the distributor's service department should be contacted in order to resolve the matter.
- If the matter still remains unresolved then contact Bombardier by writing to us at the address listed below.

In Europe and Russia:

Bombardier-Nordtrac Oy  
Box 8040  
FIN-96101 ROVANIEMI  
FINLAND



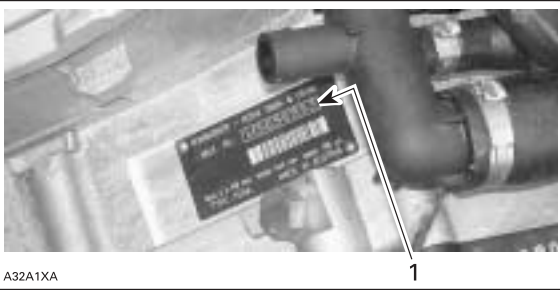

A32A1XA

4-tec models

1. Engine serial number

## CONTROLS/INSTRUMENTS

**NOTE!** Some controls/instruments do not apply to some models. In these cases their reference numbers are deliberately missing in the illustrations. Some controls/instruments are optional on some models.

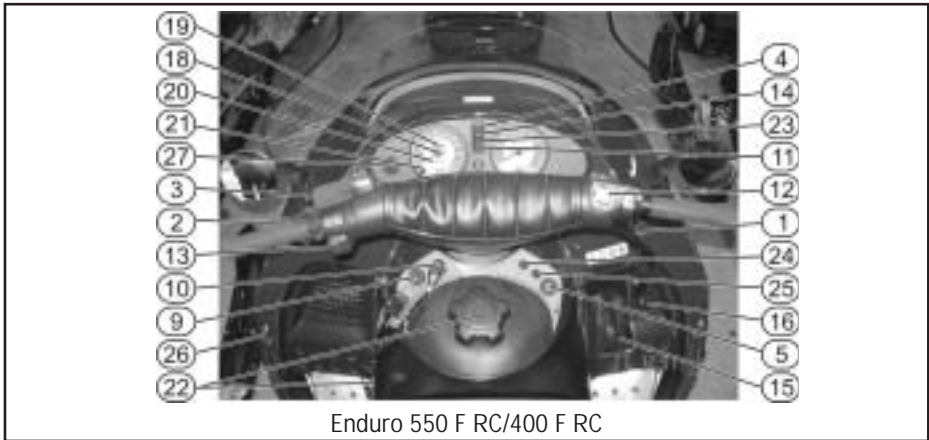

Enduro 550 F RC/400 F RC

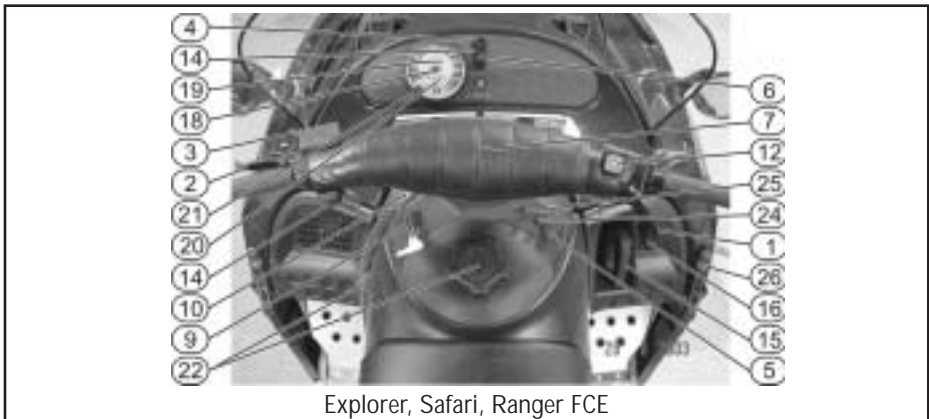

Explorer, Safari, Ranger FCE



Rave 800 HO, Enduro 600 HO/500, Sport Touring 800 SDI/600 HO, Ranger Mountain, Ranger V-1000, Ranger 600 (not instruments)



Ranger 600 LC

1. Odometer
2. Tachometer
3. Trip meter
4. Trip meter reset button
5. High beam pilot lamp
6. Oil pilot lamp
7. Coolant pilot lamp
8. Tachometer
9. DESS pilot lamp



5900 FCE/6900 FCE



ST 600



59 Yeti



Forest Fox S



ST 550 F



Racing (not instruments)



Racing model instruments

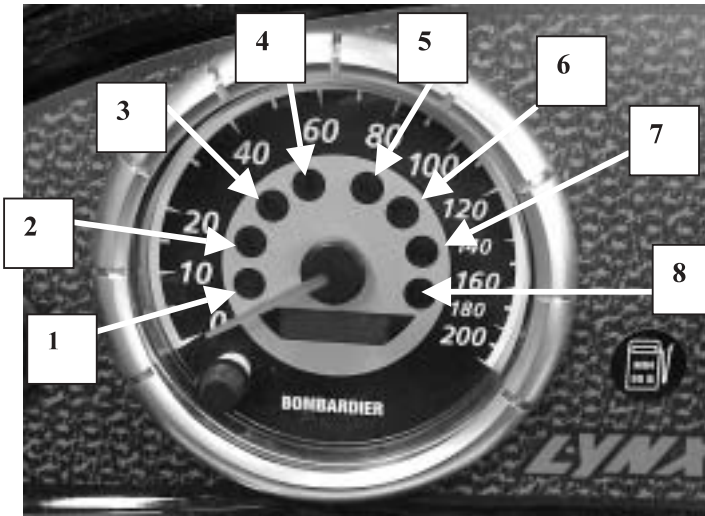

- |  |                                   |
|--|-----------------------------------|
| 1. Engine Management System (EMS) pilot lamp | 5. High beam pilot lamp           |
| 2. Air shock pilot lamp (not in use on Lynx) | 6. Low battery voltage pilot lamp |
| 3. Oil pressure pilot lamp                   | 7. DESS pilot lamp                |
| 4. Cooling liquid pilot lamp                 | 8. Brake pilot lamp               |

## 1) THROTTLE LEVER

Located on the right side of handlebar. When compressed, it controls the engine speed and the engagement of the transmission. When released, engine speed returns automatically to idle.

## 2) BRAKE LEVER

Located on the left side of handlebar. When compressed, the brake is applied. When released, it automatically returns to its original position. Braking effect is proportional to the pressure applied on the lever and to the type of terrain and its snow coverage.

## 3) PARKING BRAKE BUTTON OR LEVER

Located on left side of handlebar. Parking brake should be used whenever snowmobile is parked.

Whenever parking brake is applied and engine is running, injection oil level/parking brake pilot lamp lights up to remind you that it is engaged. Never leave your snowmobile on downhill only with parking brake engaged.

### WARNING!

Make sure parking brake is fully disengaged before operating the snowmobile.

### Mechanical brake

To engage mechanism, squeeze brake lever and maintain while pulling button with the other hand. There are 2 retaining notches on button lever; pull button its locks on a notch then release brake lever.

To release mechanism, squeeze brake lever then fully push parking brake button. Always release parking brake before riding.

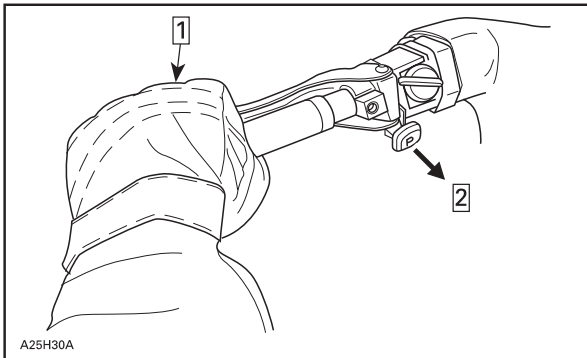

Step 1: Squeeze and hold

Step 2: Fully pull

### Hydraulic brake

To engage mechanism, squeeze brake lever and maintain while pulling locking lever with a finger. Brake lever is now compressed halfway applying brakes.



To release mechanism, squeeze brake lever. Locking lever will automatically return to its original position. Brake lever now returns to rest position. Always release parking brake before riding.

### **WARNING!**

Locking keeps brake lever engaged and keeps pressure against brake disc. Anyhow, this pressure may decrease so low, that it will not keep vehicle in place. Never leave the snowmobile on hill only with parking brake applied.

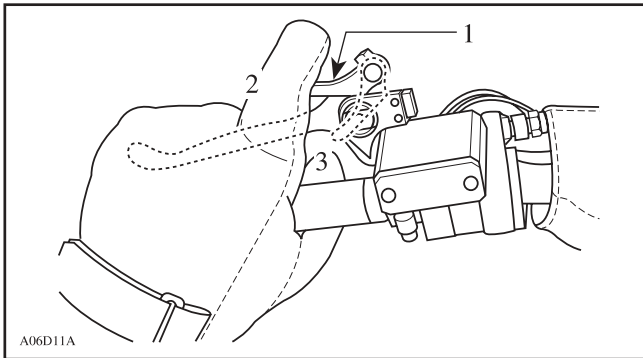

1. Locking lever
2. OFF
3. ON

## **4) BRAKE/PARKING BRAKE/LOW OIL LEVEL PILOT LAMP (Red)**

Lights when brake or parking brake is applied (with engine running). This pilot lamp also lights up when injection oil level is low (with engine running). Check oil level and replenish as soon as possible.

## **5) GEAR SHIFT LEVER OR RER BUTTON**

### **Gear box models**

These models are equipped with 4-position gear shift lever.

These models have 2 gears forward, reverse gear and free position between 1. and 2. gear.



### Shifting procedure

**NOTE!** Shift the gear only when engine is running at idle and the speed is below 20 km/h. Come to complete stop before selecting reverse gear.

Do not force lever. If unable to shift, apply throttle to move snowmobile. Stop vehicle, then try again.

### Ranger V-1000

This model is equipped with a mechanical reverse controlled by a 2-position gear shift lever.

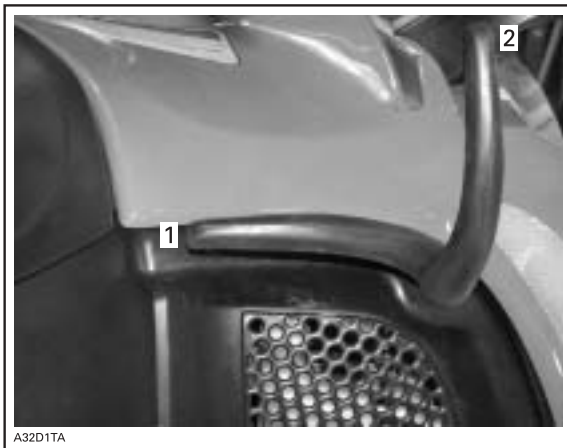

1. Forward
2. Reverse

**NOTE:** These models: Whenever shifting the gear the snowmobile has to be completely stopped, otherwise the gear system may get damaged.

## Electric reverse

### Some models

These models are equipped with an electronic reverse (RER), which is controlled by a RER button. Reverse shift can be used when the snowmobile is stopped and engine is running at idle.

Engine is running automatically forward when the snowmobile is started after stalling or stopping. Shifting procedure will take place only when the engine is running.

It is recommended to warm up the engine to its normal operating temperature before shifting.

### Shifting in reverse

With the snowmobile completely stopped and engine running at idle, press and release the RER button.

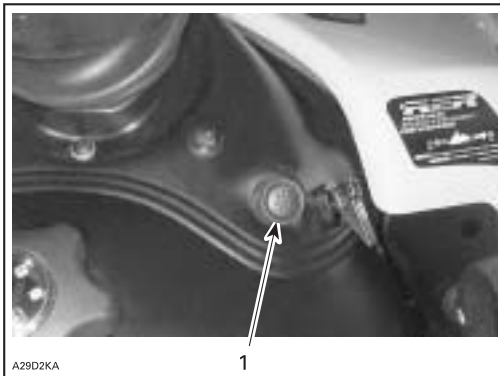

#### 1. RER button

The reverse pilot lamp blink and a reverse alarm will sound once every second with a half a second duration when the snowmobile is engaged in reverse.

Apply throttle slowly and evenly. Allow drive pulley to engage then accelerate carefully.

### Shifting in forward

With the snowmobile completely stopped and engine running at idle, press and release the RER button. Reverse pilot lamp and reverse alarm will stop.

Apply throttle slowly and evenly. Allow drive pulley to engage then accelerate carefully

### RER Modification at high altitude

At high altitude, the RER system needs a different engine timing curve to work properly.

## Non DPM™ Liquid-Cooled Models

Before using the reverse system, first select the altitude mode that changes engine timing curve.

To do so, push and hold START/RER button with engine running. After 2 seconds, one beep is heard meaning that the low altitude mode is can be selected. Releasing START/RER button just after hearing that one beep will select the low altitude mode. The reverse system is now ready to operate in high altitude regions. Shifting in reverse is achieved as described above in Shifting in Reverse.

To select high altitude mode, push and hold START/RER button until 2 beeps are heard. Release button within one second. The reverse system is now ready to operate in hig (**n**) altitudes. Shifting in reverse is achieved as described above in Shifting in Reverse.

As long as the START/RER button is pushed and held the RER system switches from one mode to the other. One beep then 2 beeps the one beep then 2 beeps and so on are heard with one second interval. The mode to be selected corresponds to the last beep code heard.

The selected altitude mode is kept in memory until a new one is chosen — whether the engine is stopped or not.

## DPM Liquid-Cooled Models

These vehicles are equipped with a Digital Performance Management (DPM) system. This system takes care of the altitude mode required by the RER.

No START/RER button operation is needed to select a mode. Just follow Shifting in Reverse above.

## 6) REVERSE PILOT LAMP

This pilot lamp will light up when reverse is selected.

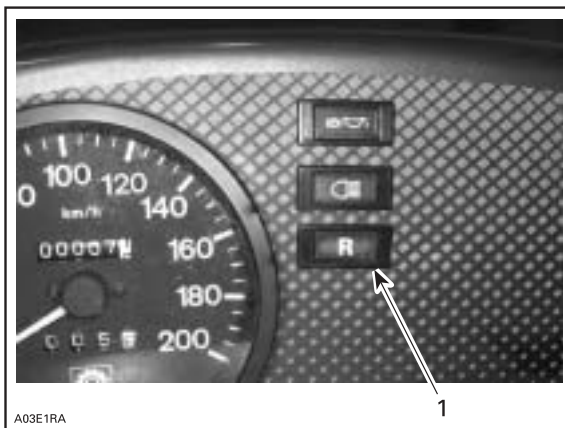

1. Reverse pilot lamp

## 7) HANDLEBAR

The handlebar controls the steering of the snowmobile. As the handlebar is rotated to right or left, the skis are turned right or left to steer the snowmobile. Handlebar height is adjustable. See an authorized Lynx dealer.

## 8) HOLDING STRAP

Holding strap provides a grip for driver when side-hilling.

## 9) IGNITION SWITCH/ START/RER BUTTON

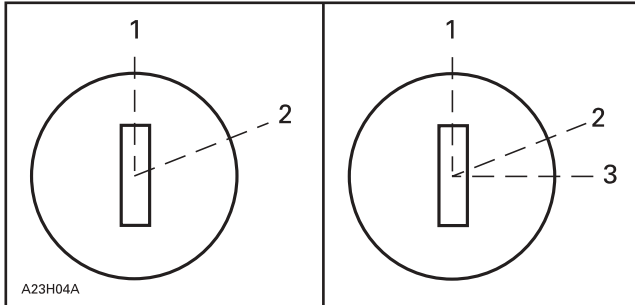

Manual start

1. OFF
2. ON

Electric start models

1. OFF
2. ON
3. START

### Manual Starting

To start the engine, turn the key to ON position, then pull rewind starter grip, To stop the engine, turn the key to OFF position.

### Electric Starting

To start engine, turn key to START position and hold until engine has started. See illustration above.

**NOTE:** Do not use electric starter for more than 15 seconds. A rest period should be observed between the cranking cycles to let electric starter cool down. If start/rer button is pressed when engine has started it could damage electric starter mechanism.

Release key as soon as the engine starts. Key returns to ON position as soon as it is released.

if engine does not start on first try, turn key back to OFF position and wait a few seconds before restarting. To stop engine, turn key to OFF position.

**NOTE:** Engine may be manually started with rewind starter if necessary.

If starter does not operate, check starting system fuse condition. refer to FUSES.

### **START/RER button**

START/RER button has two functions.

When the engine is not running, depressing the START/RER button and hold until engine has started.

When the engine is running, depressing the START/RER button will command the engine to reverse crankshaft rotation as driving the snowmobile in reverse is achieved by changing the direction of rotation of the engine, not by shifting the chaincase in reverse gear.

When depressing the START/RER button, the MPEM will practically slow down the engine RPM to a stop and advance the ignition timing to cause crankshaft rotation reversing.

Engine will automatically shift into forward when starting after stopping or stalling.

Shifting procedure will take place only when the engine is running.

If engine is running at a speed above 3800 RPM, the reverse function of the START/RER button is cancelled.

It is recommended to warm up the engine to its normal operating temperature before shifting.

### **Start Mode**

To start engine, push START/RER button and hold until engine has started.

**NOTE!** Do not hold START/RER button more than 10 seconds. A rest period should be observed between the cranking cycles to let starter cool down. Holding START/RER button when engine has started could damage starter mechanism.

## **10) TETHER CUT-OUT SWITCH**

It shuts off engine preventing snowmobile to runaway if the operator falls off the vehicle accidentally.

### **Operation**

Attach to clothing eyelet than snap tether cord cap over post before starting engine.

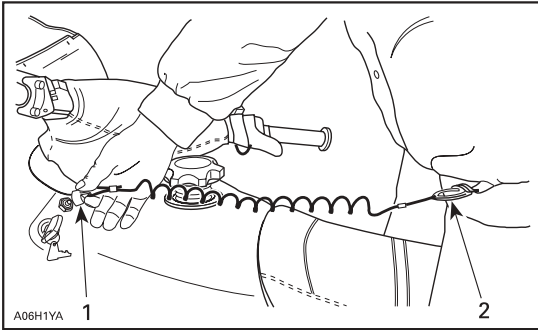

Typical

1. Snap over post
2. Attach to eyelet

If emergency engine shut off is required, completely pull tether cord cap from post.

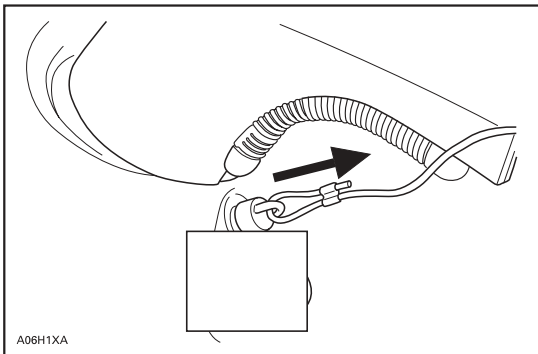

Typical

### Some Liquid-Cooled Models

On these models tether cut-out switch is part of tether cut-out system. This system serves 3 functions.

It shuts off engine preventing snowmobile to runaway if the operator falls off the vehicle accidentally.

Through the D.E.S.S.<sup>™</sup> (Digitally Encoded Security System), it acts as a lock by preventing unauthorized use of your snowmobile thus deterring theft.

Finally, it prevents unintentional electric starter operation in vehicles so equipped by disabling the electric starter and ignition circuits in the MPPEM or ECU.

### DESS (Digitally Encoded Security System) Description

This system is digitally encoded to provide you and your snowmobile with the equivalent security as a conventional lock key.

The tether cord cap provided with your snowmobile contains an electronic chip in which a unique digital code is permanently memorized. Your authorized Lynx dealer programs this key code in the MPEM or ECU of your snowmobile to allow engine operation above 3000 RPM if and only if this unique code has been read after engine starting.

If a tether cord cap with different code is installed, the engine will start but cannot reach drive pulley engagement rpm's to move vehicle.

### **Additional Tether Cord Caps**

The MPEM/ECU of your snowmobile can be programmed by your authorized Lynx dealer to accept 8 different key codes (tether cord caps).

### **DESS Pilot Lamp Codes**

DESS pilot lamp blinking slowly (one time per 1,5 second) means that a bad connection has been detected. Vehicle can not be driven.

To check for bad connection, remove tether cord cap. Make sure the tether cord cap is free of dirt or snow. Reinstall cap and restart engine. If a blink still occurs, contact an authorized dealer.

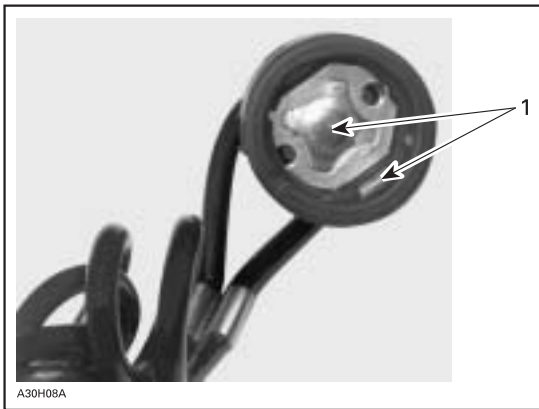

1. Free of dirt and snow

A DESS pilot lamp blinking 3 times per second means that you have installed a cap with a code that MPEM of this snowmobile was not programmed to recognize (wrong key). Vehicle can not be driven.

## **11) DESS PILOT LAMP**

This lamp will light up to confirm DESS status. Refer to previous paragraphs for description.

## **12) ENGINE CUT-OUT SWITCH**

This push-pull type or toggle type switch is located on the right side of the handlebar. To stop the engine in an emergency, select OFF position and simultaneously apply the brake. To restart, button must be at the ON position.



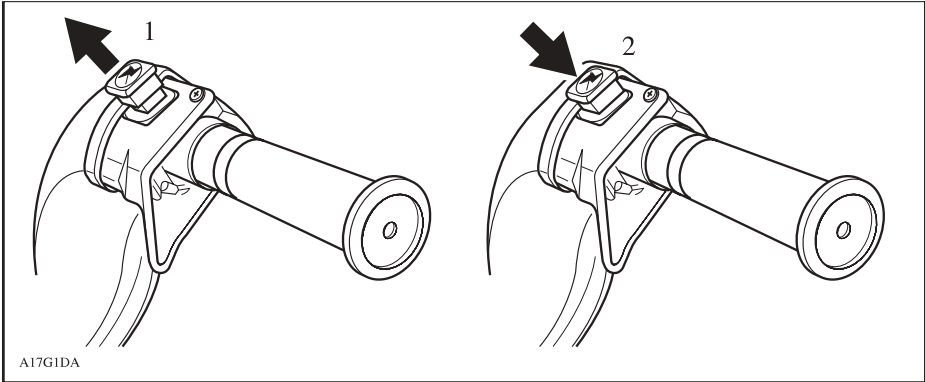

1. ON
2. OFF

All operators of the snowmobile should familiarize themselves with the function of this device by using it several times on first outing and whenever stopping the engine there-after. This engine cut-out procedure will become a reflex and will prepare operators for emergency situations requiring its use

### 13) HEADLAMP DIMMER SWITCH

Located on left hand side of handlebar, allows selection of headlamp beam. Note that lights are automatically ON whenever the engine is running.

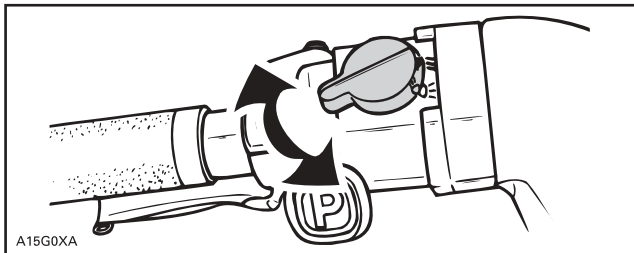

Some models

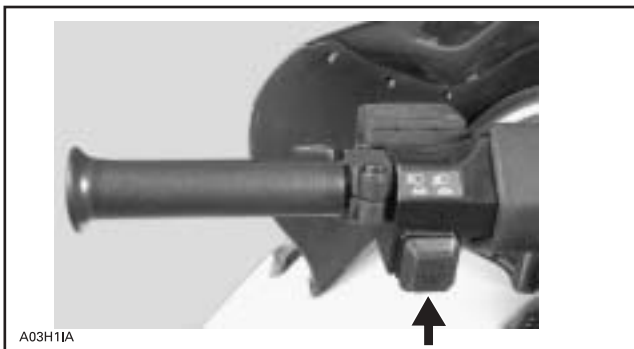

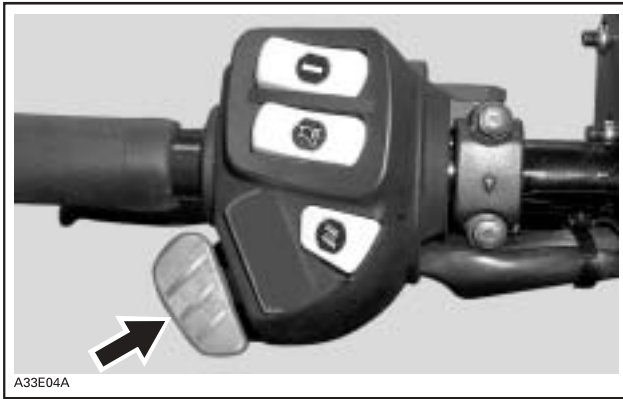

## 14) HIGH BEAM PILOT LAMP (Blue)

Lights when headlamp is on HIGH beam.

### Oil pilot lamp

#### 2-tec models

This pilot lamp will glow up when injection oil level is low. Stop vehicle in a safe place then, replenish injection oil reservoir.

#### 4-tec models

This pilot lamp will glow up when engine oil pressure is too low. Stop vehicle in a safe place then, check oil level and replenish as described in FLUID LEVEL.

Restart engine, oil pilot lamp must turn off after few seconds. If oil pilot lamp still glows up, stop engine and have lubrication system inspected by an authorized Lynx dealer.

### Low battery voltage pilot lamp

This lamp will light up to indicate a low battery voltage condition. See an authorized Lynx dealer as soon as possible.

### Engine Management System (EMS) pilot lamp

This lamp will light up to indicate a trouble. Refer to "TROUBLESHOOTING" for trouble code meaning and remedy.

## 15) REWIND STARTER HANDLE

Auto-rewind type located on right hand side of snowmobile. Pull handle slowly until a resistance is felt then pull vigorously. Slowly release handle.

## 16) CHOKE LEVER

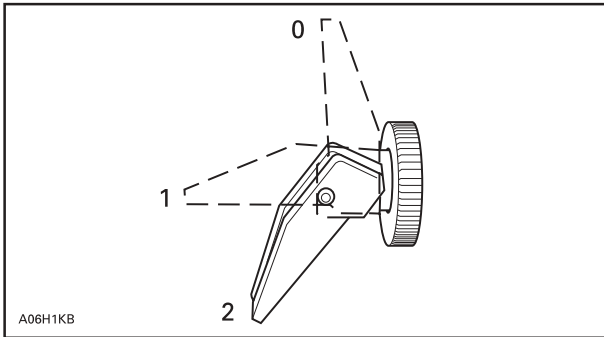

- 0. OFF
- 1. Position 1
- 2. Position 2

### Initial Cold Starting

**NOTE:** Do not operate the throttle lever with the choke lever on.

Move the choke lever to position 2 and start the engine. As soon as the engine starts move the lever to position 1. After a few seconds (10 seconds maximum) move the choke lever to position OFF.

**NOTE:** In severe cold weather, colder than  $-20^{\circ}\text{C}$  you may need to flip choke lever from OFF position to position 1 a couple of times once engine is started.

### Warm engine starting

Start the engine without any choke. If the engine will not start after two pulls of the rope or two 5 second attempts with the electric starter move choke lever to position 1. Start the engine without activating the throttle lever. As soon as the engine starts move the choke lever to OFF.

## 17) PRIMER BUTTON

Pull and push button. It is not necessary when engine is warm.

To prime, activate button until a pumping resistance is felt. From this point, pump 2 or 3 times to inject fuel in intake manifold. After priming, ensure that primer button is pushed back.

**NOTE:** In very cold temperature, it is recommended to rotate primer button 3 - 4 turns prior to pull it. This will eliminate the possibility of sticking.

## 18) SPEEDOMETER

Fan models and some liquid-cooled models:

Direct reading screen shows speed in km/h.

## 19) ODOMETER

Odometer records the total distance travelled in kilometers. It can be reset when needed.

Push and hold mode button for 2 seconds to reset the trip meter.

Using the button situated on left side you can change the display for the trip meter, hour meter or odometer.

## 20) TRIP METER

Records the distance travelled. it can be reset when needed.

Push hold mode button for 2 seconds to reset the trip meter.

## 21) TRIP METER RESET BUTTON

To reset the meter, push the button until all the numbers are zero (0).

Using the button situated on left side you can change the mode to trip meter, hourmeter or odometer.

Push and hold the button for 2 seconds to reset the hourmeter.

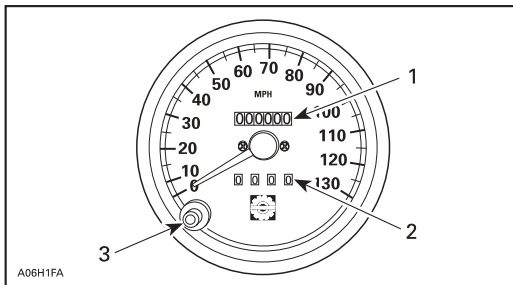

1. Odometer
2. Trip meter
3. Reset button



Electronic speedometer

### Some liquid-cooled models

These models are equipped with electronic speedometer. It shows the speed either in kilometers or miles per hour.



### Electronic speedo- and tachometer

Records total distance travelled until it is reset.

#### Mode button

Depress the mode button to change display. Each time engine is started, display shows odometer. From that point depressing mode button again to return the odometer.

Depressing mode button again will change display for the resettable hourmeter. Push mode button again to return to odometer.

Push and hold mode button for 2 seconds to reset the tripmeter or the resettable hourmeter depending on the one displayed.

**NOTE: Some models:** At vehicle speed of 90 km/h and more the mode LCD screen will show speed only instead of the selected mode.

#### Resettable hourmeter

Records engine running time in hours and minutes since it has been reset.

#### All models

Push and hold mode button for 2 seconds to reset the resettable hourmeter.

## 22) FUEL TANK CAP/GAUGE

Unscrew to fill up tank then fully tighten. Fuel tank cap features a mechanical gauge.

## WARNING!

Stop the engine before refueling. Fuel is inflammable and explosive under certain conditions. Open cap slowly. Do not smoke or allow open flames or sparks in the vicinity. Do not overfill or top off the fuel tank before placing the vehicle in a warm area. As temperature increases, fuel expands and might overflow. Wipe off any fuel spillage from the vehicle.

### 23) ENGINE OVERHEAT WARNING LIGHT (Red)

If this lamp glows; reduce snowmobile speed and run snowmobile in loose snow or stop engine immediately.

### 24) HEATING GRIP SWITCH

It is a three –position switch. Select the desired position to keep your hands at a comfortable temperature.

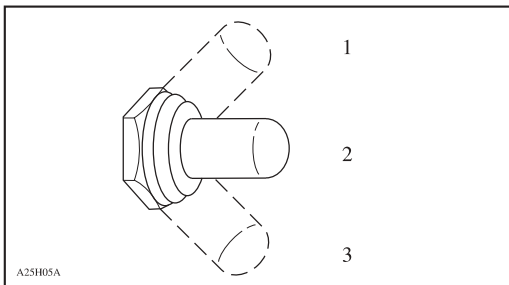

1. HOT
2. OFF
3. WARM

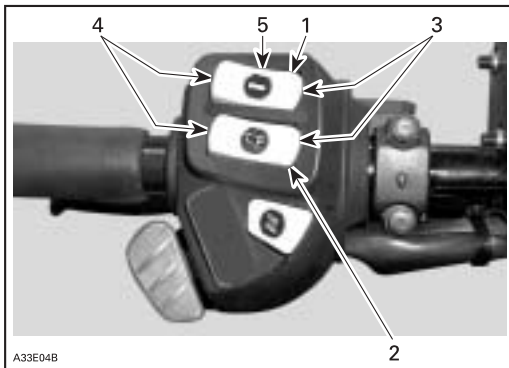

#### SOME MODELS

1. Heated grip switch
2. Heated throttle lever switch
3. Hot
4. Warm
5. OFF

### 25) HEATED THROTTLE LEVER SWITCH

Three-position switch. Select the desired position to keep your right thumb at a comfortable temperature. See illustration.

## Rear passengers heating grip switches

Three-position switch. Select the desired position to keep rear passenger's hands at comfortable temperature.

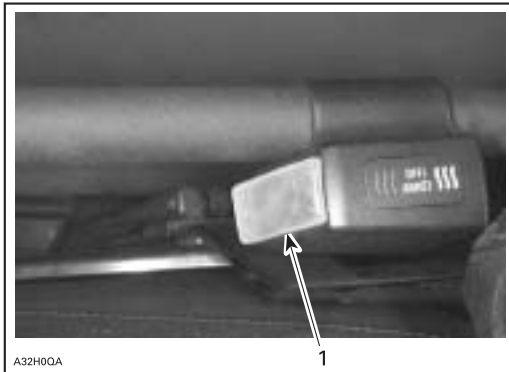

Right side of passenger grab handle

1. Heating grab handle switch

## 26) HOOD LATCHES

Stretch and unhook the latches to unlock the hood from its anchors. Lift hood gently until stopped by retaining device. Close hood slowly then hook up latches.

## 27) POWER OUTLET

A 12-volt electric appliance may be connected to that jack connector. Electric current is supplied when ever engine is running. See FUSES for electric power outlet fuse location.



## 28) FUSES

To remove fuse from holder, pull fuse out. Check if filament is melted.

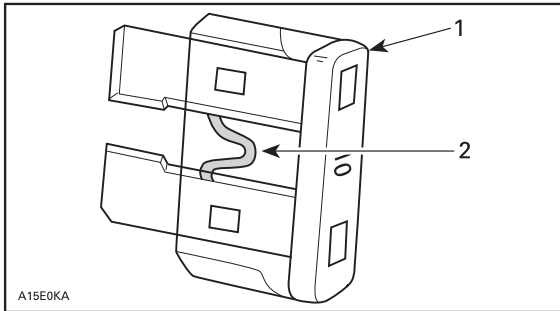

1. Fuse
2. Check if melted

### Fuse for starting system and electric power outlet

Starting system and electric power outlet is protected (if equipped) with 20 ampere fuse. If the starter and electric power outlet is out of function, check the fuse condition and replace if needed.

**NOTE:** Do not use a higher rated fuse as this can cause severe damage to electric components and/or fire.

### 4-Tec models and Sport Touring 800 SDI

To open fuse box push on cover tab and tilt cover.



1. Push tab



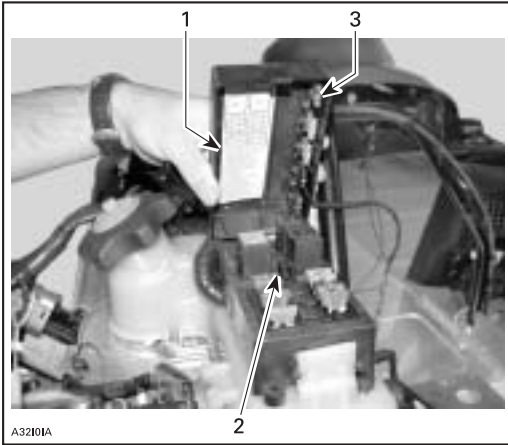

- 1. Fuse description decal
- 2. Fuse remover/installer
- 3. Spare fuses

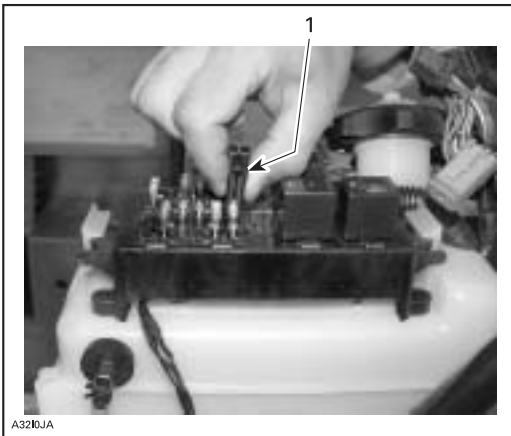

- 1. Fuse remover/installer

## 29) FRONT GRAB HANDLE / FRONT BUMPER

To be used whenever front of snowmobile requires manual lifting.

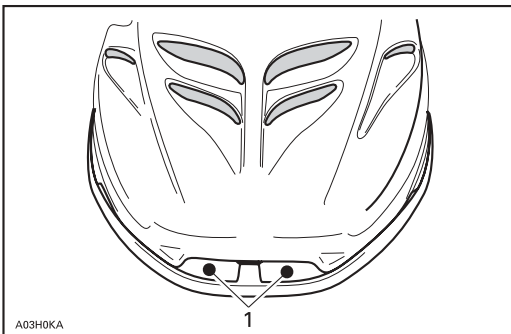

- 1. Front grab handles

**NOTE:** Do not use skis to pull or lift snowmobile.

### 30) STORAGE COMPARTMENT

Depending on model, storage compartment situates either in engine compartment, under the seat or inside of the seat.

### 31) REAR RACK

Some models

**NOTE:** Always readjust suspension according to the load. The capacity of this rack is limited. Ride at very low speed when loaded. Avoid speed over bumps.

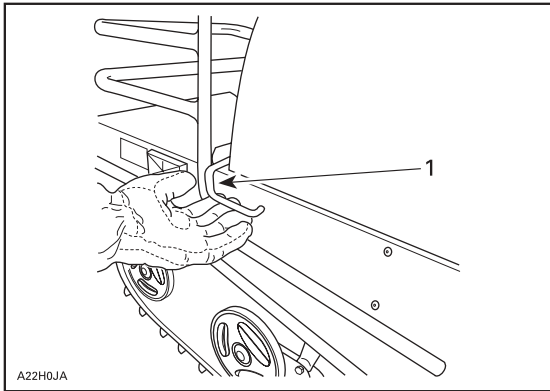

1. Opening latch

### 32) TOOL KIT

A tool kit containing tools for basic maintenance is supplied with the engine. Tool bag is located under the seat or hood.

### 33) SPARK PLUG HOLDER

Some models

To keep spare spark plugs dry and prevent shocks that might affect the adjustment or break them, a holder is provided in engine compartment.

Firmly tighten them into the holder with spark plug socket (in tool kit) to ensure that they will not be loosened by vibrations.

**NOTE:** Spare spark plugs are not supplied with a new snowmobile.

**NOTE:** Adjust spare spark plug gap according the TECHNICAL DATA before installation.

**CAUTION:** Do not attempt to adjust gap on spark plug BR9ECS; it is not adjustable.

### 34) SEAT STRAP

Seat strap provides a grip for the passenger.

### 35) HITCH

The hitch can be used to pull most equipment. Use a rigid tow bar.

**NOTE!** Remember to lock the hitch locking latch with a lock pin.

Check the decal on your own vehicle. There is a description of how much load is allowed and to transport and to pull.

### 36) ADJUSTABLE SUSPENSION

Snowmobile handling and comfort depend upon suspension adjustments.

Choice of suspension adjustments vary with carrying load, driver's weight, personal preference, riding speed and field condition.

**NOTE:** Some adjustments may not apply to your snowmobile. Use special keys in tool kit.

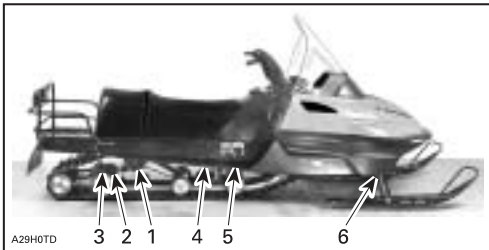

1. Rear springs - comfort and ride height
2. Suspended extension – reverse performance, load and snow conditions
3. Shackle movement – reverse performance, load and snow conditions
4. Center spring - handling
5. Stopper strap – snowmobile weight transfer
6. Front shock - handling

#### Guidelines to adjust suspension

The best way to set up suspension, is to start from factory settings then customize each adjustment one at a time. Adjustments 2 through 6 are interrelated. It may be necessary to readjust center spring after adjusting front springs for instance. Test run the snowmobile under the same conditions; trail, speed, snow, driver riding position, etc. Change one adjustment and retest. Proceed methodically until you are satisfied.

**NOTE:** Whenever adjusting rear suspension, check track tension and adjust as necessary.

Slight suspension bottoming occurring under the worst riding conditions indicates a good choice of spring preload.

## 1. Rear Springs — Comfort

**IMPORTANT:** Make sure that all objects to be transported are in place in rear rack and under the seat.

When driver and passenger (if applicable) take place, rear of snowmobile should collapse by 50 to 75 mm.



*PROPER ADJUSTMENT*  
A. 50 to 75 mm



*Too soft of adjustment*



*1. Increase spring preload*



*Too hard of adjustment*



1. From the highest position, turn adjuster to select lowest position then, turn adjuster to the desired position

## 2. Suspended Extension Adjustment

Suspended extension can be adjusted according to the load and snow conditions.

For better deep snow performance or to increase reverse performance in deep snow; first loosen lock nut then tighten nut 3/4 turn after contacting washers. Retighten lock nut. Adjust the same on both sides.

For trail riding with a load or for pulling a load, first loosen lock nut. Turn to a maximum preload of 3 turns after lock nut touching washers. Retighten lock nut. Adjust the same on both sides.

## 3. Shackle Movement Limiter

Forest Fox : Install rubber damper if you are mainly pulling a load. Rubber dampers improves the handling when pulling a load.

For deep snow riding, do not install horse shoe washers.

For trail riding with passenger and/or weight; install 1 horse shoe washer under each rubber stoppers.

For trail ride with heavy load and/or pulling a load ; install 2 horse shoe washers under each rubber stoppers.

**CAUTION:** Always install same amount of washers on both sides.

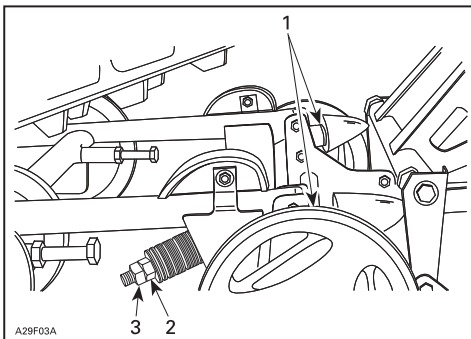

1. Horse shoe washer(s)
2. Nut
3. Lock nut

#### 4. Center Spring — Steering Behavior

Ride at moderate speed on a trail. If handlebar is felt too hard to turn, adjust centre spring accordingly.

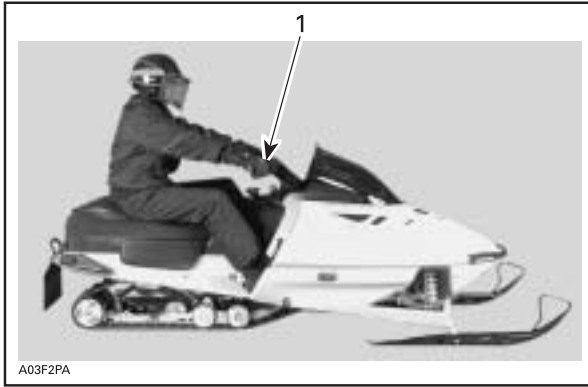

TYPICAL —GOOD ADJUSTMENT AT MODERATE SPEED  
1. Handlebar easy to turn – neutral steering attitude

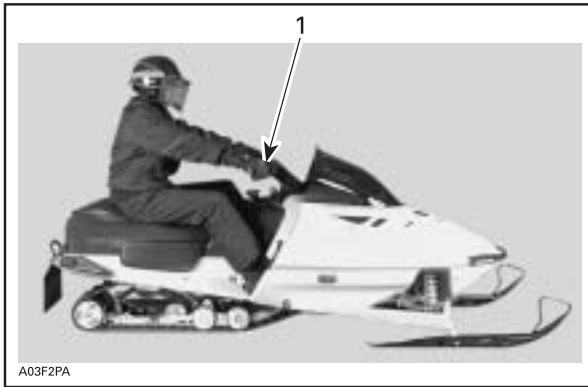

TYPICAL — TOO SOFT OF ADJUSTMENT  
1. Handlebar harder to turn — oversteering attitude

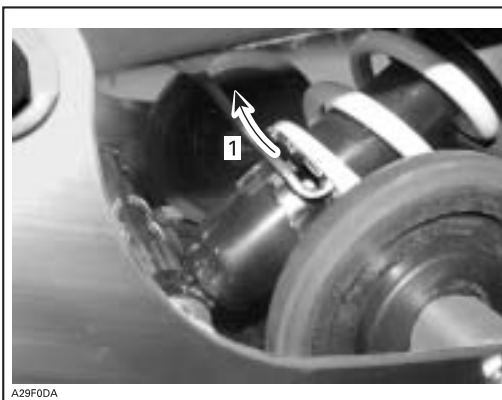

1. Use adjuster wrench provided in tool kit to increase preload

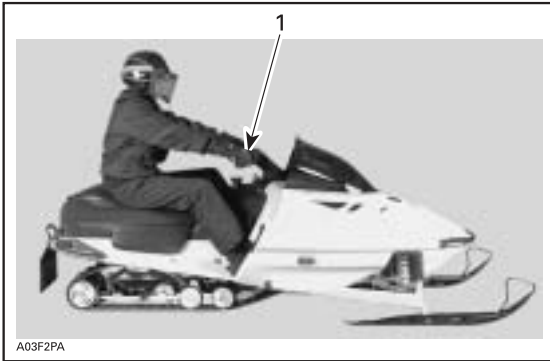

TYPICAL — TOO HARD OF ADJUSTMENT — TOO MUCH PRELOAD

1. Handlebar is very easy to turn – understeering attitude

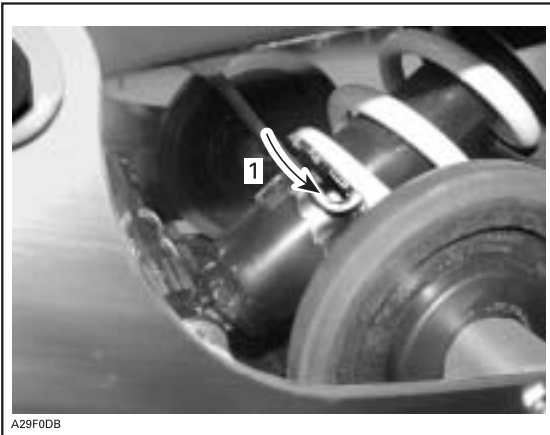

1. Use adjuster wrench provided in tool kit to decrease preload

### 5. Stopper Strap — Weight Transfer

Ride at low speed then fully accelerate. Note steering behavior. Adjust stopper strap length accordingly.

**NOTE:** Whenever stopper strap length is changed, track tension must be readjusted.

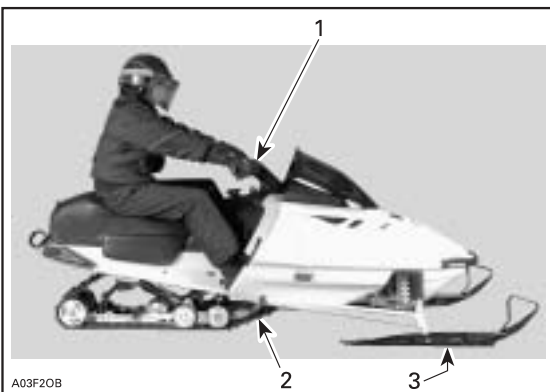

TYPICAL — GOOD ADJUSTMENT AT FULL ACCELERATION

1. Comfortable steering  
 2. Good weight transfer to the track  
 3. Light pressure of skis on the ground



TYPICAL — TOO LONG STRAP  
1. Skis lift off the ground

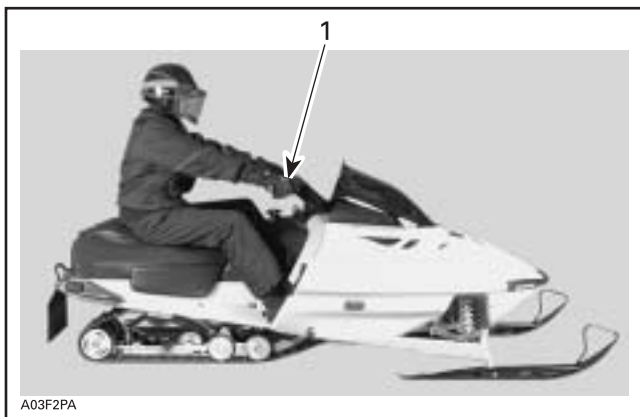

TYPICAL — TOO SHORT STRAP  
1. Heavy steering

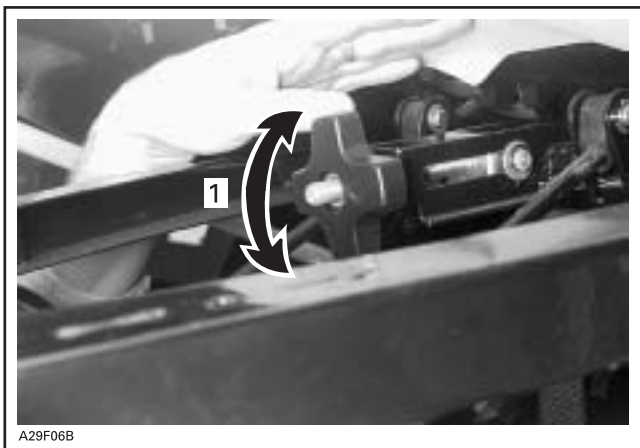

1. Screw or unscrew knob to vary strap length



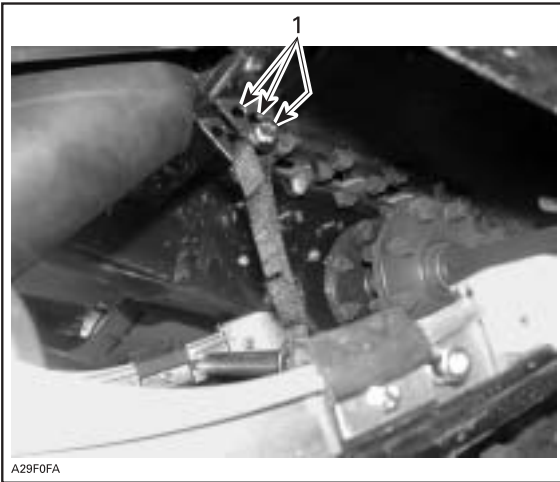

1. Bolt stopper strap to a different hole

### 6. Front Springs — Handle

Ride at moderate speed and check for proper handling. Adjust front springs accordingly.

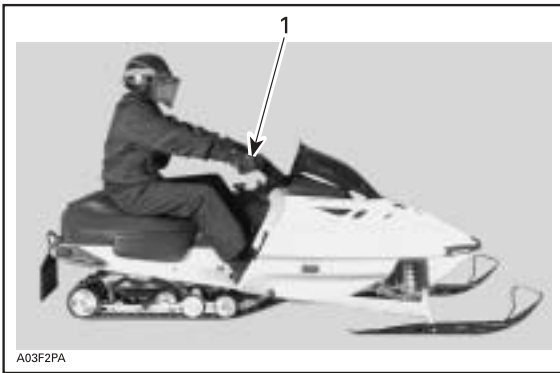

TYPICAL — PROPER ADJUSTMENT

1. Good handling and comfortable steering

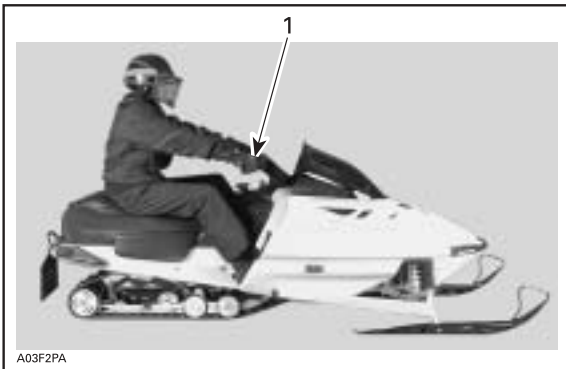

TOO SOFT OF ADJUSTMENT

1. Bad handling

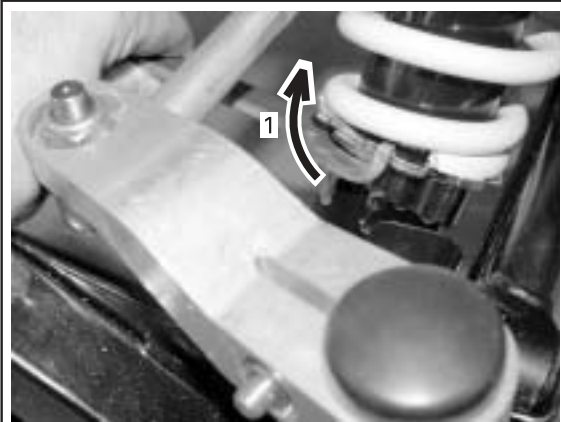

A29F0EA

1. Increase spring preload



A03F2PA

TOO HARD OF ADJUSTMENT  
1. *Steering hard to turn*

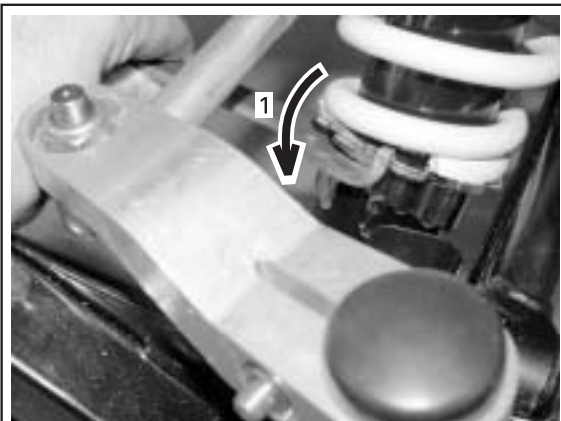

A29F0EB

1. Decrease spring preload

## SUSPENSION TROUBLESHOOT

PROBLEM	CORRECTIVE MEASURES
Front suspension wandering	-Check ski alignment and camber angle adjustment. See an authorized Lynx dealer. -Reduce ski ground pressure. Reduce front suspension spring preload. Increase center spring preload. Reduce rear spring preload.
Snowmobile seems unstable and seems to pivot around its center.	-Reduce rear suspension front arm pressure. Reduce center spring preload. Increase rear spring preload . Increase front suspension spring preload.
Steering feels too heavy.	-Reduce ski ground pressure. Reduce front suspension spring preload. Increase center spring preload.
Rear of snowmobile seems too stiff.	-Reduce rear spring preload.
Rear of snowmobile seems too soft.	-Increase rear spring preload.
Rear suspension front shock absorber is frequently bottoming.	-Lengthen stopper strap. -Increase center shock preload.
Track spins too much at start.	-Lengthen stopper strap. -Change driving position.

### In deep snow

When operating the snowmobile in deep snow, it may be necessary to vary extension adjustment, stopper strap and/or riding position, to change the angle at which the track rides on the snow. Operator's familiarity with the various adjustments as well as snow conditions will dictate the most efficient combination.

# FUEL AND OIL

## Recommended fuel

Refer to TECHNICAL DATA in the end of this manual.

**NOTE:** Never experiment with other fuels or fuel rations. The use of unrecommended fuel can result in snowmobile performance deterioration and damage to critical parts in the fuel system and engine components.

## WARNING!

Do not overfill or top off the fuel tank before placing the vehicle in a warm area. As temperature increases, fuel expands and might overflow. Fuel is inflammable and explosive under certain conditions. Wipe off any fuel spillage from the vehicle.

## Fuel System Antifreeze

When using oxygenated fuel, additional gas line antifreeze or water absorbing additives are not required and should not be used.

We highly recommend the use of isopropyl base gas line antifreeze in a proportion of 150 mL of gas line antifreeze added to 40 liters of gas.

## Recommended oil

**CAUTION:** Do not mismatch oil reservoir cap with fuel tank cap. On some models there is fuel gauge together with fuel tank cap. Oil reservoir cap is identified "OIL". Use only oil, which flows at -40°.

Oil is in injection oil reservoir.

Use Bombardier snowmobile injection oil or synthetic injection oil.

Use only 2-stroke engine oil.

### MODEL

*Sport Touring 800 SDI  
2-stroke*

### OIL TYPE

*Formula XP-S II  
XP-S II or fully synthetic equivalent oil has  
to be used on this model*

**NOTE:** Formula XP-S II is fully synthetic oil.

BOMBARDIER injection oil is a blend of basic oil and additives especially selected to ensure unequalled lubrication, engine cleanliness and minimum spark plug fouling. The BOMBARDIER FORMULA XP-S synthetic injection oil provides superior lubrication, reduced engine component wear and oil deposit, thus maintaining maximum-level performance. This synthetic injection oil meets the latest ASTM and JASO standards.

**CAUTION:** Never use four-stroke mineral or synthetic oil. Do not mix these with out-board motor oil. Do not use NMMA TC-W, TC-W2 or TC-W3 outboard oil. Avoid mixing different brands of API TC oil as resulting chemical reactions may cause severe engine damage.

Always maintain a sufficient amount of recommended oil in the injection oil reservoir.

**CAUTION:** Check level and refill every time you refuel. Do not mismatch oil reservoir cap with fuel tank cap. Install cap that is identified with OIL

#### 4-tec models

These models are equipped with 4-stroke engine. Use Bombardier 4-stroke synthetic oil 0W 40 (P/N: 293 600 054) 12x1L.

#### Gear box oil

Recommendation 75W140 (P/N 320007).

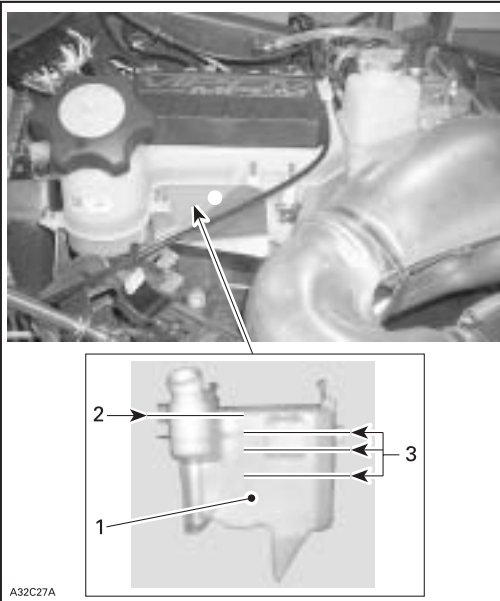

1. Injection oil reservoir
2. Max level: 13 mm from top
3. Level marks ( $\frac{1}{4}$ ,  $\frac{1}{2}$ ,  $\frac{3}{4}$ )

## COLD WEATHER CARBURETION MODIFICATIONS

All vehicles has been calibrated for - 20°C. They can be operated at warmer winter temperatures without problems.

**CAUTION:** For colder temperatures than - 20°C, carburetor(s) must be recalibrated to avoid engine damage. Refer to an authorized Lynx dealer.

If additional coolant is necessary or if entire system has to be refilled, refer to an authorized Lynx dealer.

### Heated carburetor valve

The heated carburetor valve should be closed except:

- When riding between  $-5^{\circ}\text{C}$  and  $+5^{\circ}\text{C}$  in a high relative humidity.
- When riding in deep powder snow.
- When following another snowmobile which makes dust snow.

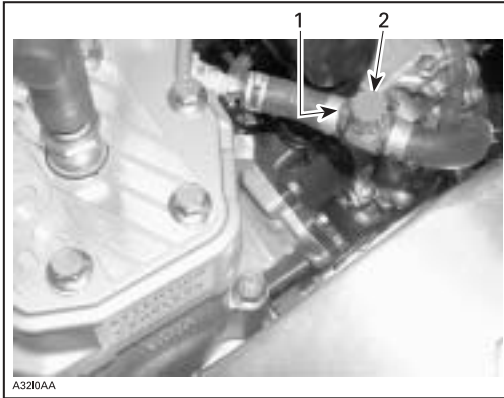

*Some liquid-cooled models*

1. ON
2. OFF

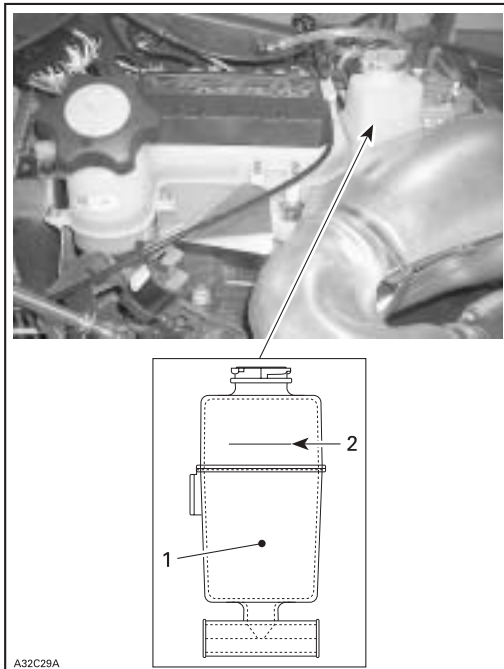

1. Coolant tank
2. COLD LEVEL (engine cold) level

## BREAK-IN PERIOD

### Engine

#### **IMPORTANT**

A break-in period of 10-15 hours ( about 500 km) is required for Rotax engines before running the snowmobile at full throttle.

During break-in period, maximum throttle should not exceed  $\frac{3}{4}$ . However, brief full acceleration and speed variations contribute to a good break-in.

#### **All models except 4-Tec models and 2-Tec SDI models:**

To assure additional protection during the initial engine break-in, 500 mL of recommended injection oil should be added to fuel for the first full filling of fuel tank. (P/N 1471599, 20x11). Have spark plugs cleaned after engine break-in.

#### **2-Tec SDI models**

To assure additional protection during the initial engine break-in, 500 ml fully synthetic XP-S II oil.

### Drive Belt

#### **All models**

A new drive belt requires a break-in period of 50 km. Avoid strong acceleration/deceleration, pulling a load or high speed cruising .

#### **10 Hour Inspection**

We suggest that after the first 10 hours of operation— 500 km — or 30 days after the purchase, whichever comes first, your snowmobile be checked by an authorized Lynx dealer.

**NOTE!** The 10 hour inspection is at expense of the snowmobile owner.

## PRE-OPERATION CHECK

- Remove snow and ice from body including seat, footrests, lights, controls and instruments.
- Verify that track and idler wheels are not frozen and free to turn.
- Activate the brake control and make sure the brake fully applies before the brake control lever touches the handlebar grip. It must fully return when released.
- Check the parking device. Apply parking brake and check if it operates easily and smoothly.
- Activate the throttle control lever several times to check that it operates easily and smoothly.
- Check operation of ignition switch, headlamp switch, taillight, brake light, pilot lamps and tether/cut-out switches.

- Verify that skis and steering operate freely. Check corresponding action of skis versus handlebar.
- Check fuel and injection oil for levels and leaks. Replenish as necessary and see an authorized Lynx dealer in case of any leaks.
- Verify that air filter(s) is free of snow, if so equipped.
- Make certain your snowmobile is pointed away from people or objects before you start it.
- Be warmly dressed with clothing designed for snowmobiling.

## **OPERATING INSTRUCTION**

### **Propulsion**

Depressing throttle lever increases engine RPM causing the drive pulley to engage. Depending on models engine RPM must be between 2500 and 4200 before drive pulley engagement will occur.

Outer sheave of drive pulley moves toward inner sheave, forcing drive belt to move upward on the drive pulley and simultaneously forcing the sheaves apart on the driven pulley.

The driven pulley senses the load on the track and limits the belt movement. The result is an optimized speed ratio between engine RPM and the speed of the vehicle at any time.

Power is transferred to the track through the chaincase or gearbox and drive axle.

### **Turning**

Handlebar controls the steering of the vehicle. As the handlebar is rotated to right or left, the skis are turned right or left to steer the snowmobile.

### **Stopping**

Before riding your snowmobile, you should understand how to stop it. This is done by releasing the throttle and gradually depressing the brake lever on the left side of the handlebar.

In an emergency, you may stop your vehicle by pressing the engine cut-out switch located near the throttle control and applying the brake.

Remember, a snowmobile cannot "stop on a dime". Braking characteristics vary with deep snow, packed snow or ice. If the track is locked during hard braking, skidding may result.

### **Starting the engine**

Check throttle lever operation.

Ensure that the engine cut-out switch is in the ON position.

Ensure that the tether cord cap is in position and that the cord is attached to your clothing eyelet.



## Primer equipped vehicles

### Starting the engine

To prime, activate button until a pumping resistance is felt.

From this point, pump 2 or 3 times to inject fuel in intake manifold.

After priming, ensure that primer button is pushed back.

**NOTE:** In very cold temperature, it is recommended to rotate primer button 3 - 4 turns prior to pull it. This will eliminate the possibility of sticking.

**NOTE:** Priming is not necessary when engine is warm.

## Choke equipped vehicles

### Initial cold starting

**NOTE:** Do not operate the throttle lever with the choke lever on.

#### When temperature is below - 10°C

Move the choke lever to position 2 and start the engine. As soon as the engine starts move the lever to position 1. After a few seconds (max.10 seconds) move the choke lever to OFF position.

**NOTE:** In severe cold weather, colder than - 20°C you may need to flip choke lever from OFF to position 1 a couple of times once engine is started.

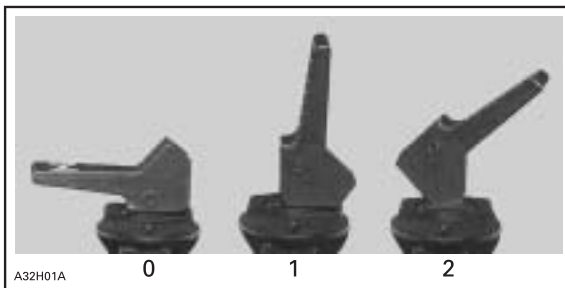

- 0. OFF
- 1. Position 1
- 2. Position 2

#### When temperature is above - 10°C

Move the choke lever to position 1.

Grab the handle firmly and start the engine or electric starter if it is equipped.

As soon as the engine starts move the choke lever to OFF.

## 2-Tec models

### Initial cold starting and warm engine starting

Grasp starter handle firmly and crank the engine or pull the tether cord or use the electric starter if it is equipped.

**CAUTION:** 2-Tec model: If the pilot lamp of the battery voltage lights on, there is not enough voltage for starting the engine. In this case, use rewind starter. If the battery is empty, engine can not be started. Charge the battery or replace it if necessary.

## 4-Tec models

### Initial cold starting and warm engine starting

Use the electric starter.

**IMPORTANT:** 4-Tec model: If the battery is empty, engine cannot be started. Charge the battery or replace it if necessary.

### Warm engine starting

Start the engine without any choke. If the engine will not start after two pulls of the rope or two 5 second attempts with the electric starter move choke lever to position 1. Start the engine without activating the throttle lever. As soon as the engine starts move the choke lever to OFF.

### Rewind starter

#### All the models except 4-Tec models

Set the key to ignition switch and turn to ON position.

Grab the handle firmly and crank the engine.

## WARNING!

Do not activate the throttle lever during starting.

**NOTE:** There is no rewind starter handle in 4-tec model.

### Electric starting

Set key to ignition switch.

Turn the key to clockwise direction until starter engages.

Release the key immediately when engine starts.

**NOTE:** Do not use electric starter longer than 10 seconds.

**NOTE:** If the vehicle cannot be started, in some reasons, with electric starter, set ignition key to ON position and start the engine using rewind starter handle.

#### All models except 4-Tec models

### Emergency starting

The engine can be started with the emergency starter rope supplied with the tool kit.

Remove belt guard.

Do not wind the starting rope around your hand. Hold rope by the handle only. Do not start the snowmobile by the drive pulley unless it is a true emergency situation. Have the snowmobile repaired as soon as possible.

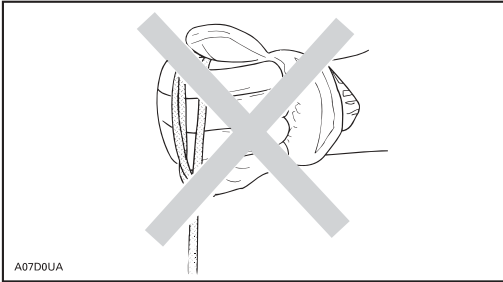

A07D0UA

Attach one end of emergency rope to rewind handle.

**NOTE:** The spark plug socket can be used as an emergency handle.

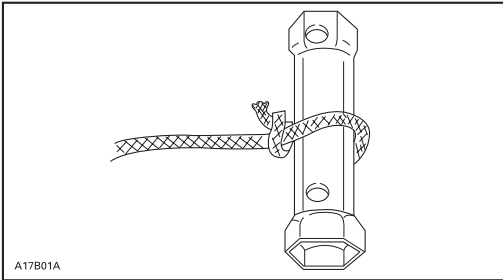

A17B01A

TYPICAL

Attach the other end of emergency rope to the starter clip supplied in the tool kit.

Hook up clip on drive pulley.

Wind the rope tightly around drive pulley. When pulled, pulley must rotate counterclockwise.

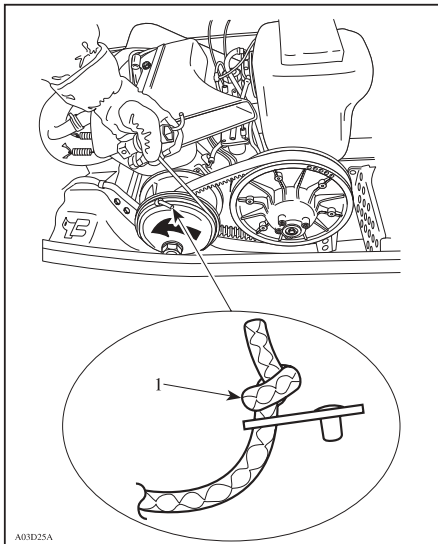

A03E25A

1. Knot on this side

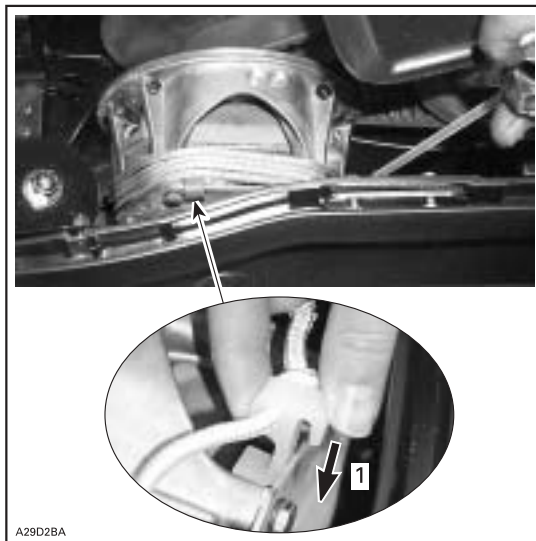

A29D2BA

1. Hook up starter clip

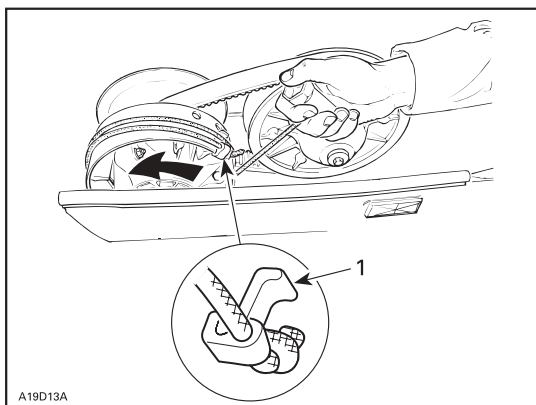

A19D13A

1. Clip

Pull the rope using a sharp, crisp pull so the rope comes free of the drive pulley . Start the engine as per usual manual starting.

When starting the snowmobile in an emergency situation, using drive pulley, do not reinstall the belt guard and return slowly to have snowmobile repaired.

### Shutting off the engine

Release throttle lever and wait until engine has returned to idle speed.

Shut off the engine using either ignition switch, engine cut-out switch or tether cut-out switch.

## WARNING!

Always remove tether cord cap and key when vehicle is not in operation in order to prevent accidental engine starting or to avoid unauthorized use by others or theft.

## Vehicle warm-up

Before every ride, vehicle has to be warmed up as follows:

Snowmobile must be securely supported by the rear bumper using a wide-base snowmobile mechanical stand. Track must be 100 mm off the ground.

Start engine and allow it to warm up two or three minutes at idle speed.

Release parking brake.

### WARNING!

Make sure wide-base snowmobile mechanical stand is stable. Stay clear of the front of vehicle and the track. Do not use too much throttle during warm-up or when track is free-hanging.

Apply throttle until drive pulley engages. Let track rotate at low speed for several turns. The lower the vehicle temperature is the longer vehicle warm-up should be.

Shut-off the engine and remove the wide base snowmobile mechanical stand.

Skis may be frozen on the ground. Grab both skis one at a time by their loops and lift their front end slightly off the ground.

After restarting engine, the vehicle can be driven at low speed for the first 2 or 3 minutes of riding. After that, it may be driven up to the legal speed limit as per normal safety practices.

## Post operation care

Shut off the engine. Install rear of vehicle on a wide-base snowmobile mechanical stand.

Remove snow and ice from rear suspension, track, front suspension, mechanism and skis.

Protect vehicle with a snowmobile cover.

## SPECIAL OPERATIONS

### Engine overheating

Fan cooled models

Shut off the engine.

Check for clogged air duct passages. Remove any foreign materials.

Check for proper fan belt condition and tension.

### Liquid cooled models

Engine overheating pilot lamp will light up if engine is too hot.

Reduce snowmobile speed and run snowmobile in loose snow or stop engine immediately.

Check for adequate coolant level. See an authorized Lynx dealer.

## Fuel flooded engine

Install new spark plugs and restart engine.

## Rear suspension slider shoe sticking

Slider shoes are cooled and lubricated by snow. When riding at moderate or high speed on a thin-snow-covered surface, slider shoes may stick on metallic track guides.

Run snowmobile on a surface covered by snow or drive snowmobile at very low speed.

Have slider shoes inspected by an authorized Lynx dealer.

**NOTE!** This situation comes up the more with high profile track. Avoid driving on hard packed snow, ice surface or other surface, that has not enough snow to ensure the lubrication.

It is noticeable that tracks with 35 mm or more high profile are not meant for the trail ride (hard surface) but only for the deep snow ride. If the vehicle which is equipped with this kind of track, is driven on hard packed snow, slider shoes may stick on track metallic parts or the track can get damaged.

## FLUID LEVELS

### WARNING!

It is recommended that the assistance of an authorized Lynx dealer be periodically obtained on other components/systems not covered in this guide. Unless otherwise specified, engine must be cold and not running. The tether cord cap must be removed for all maintenance procedures.

**CAUTION:** Vehicle must be on a level surface before checking any fluid levels.

## Brake system

Check brake fluid in reservoir for proper level. Add fluid as required.

**CAUTION:** Use only DOT 4 brake fluid from a sealed container.

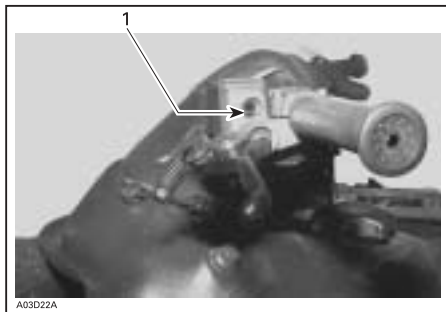

*Brake fluid reservoir  
1. Minimum*

## Chaincase models

Check the oil level by removing dipstick. Oil level must be between lower and upper marks.

**NOTE:** It is normal to find metallic particles stuck to dipstick magnet. If bigger pieces of metal are found, see an authorized Lynx dealer.

Remove metal particles from magnet.

Refill up to upper mark using recommended oil.

**NOTE:** Do not use unrecommended other types of oil when servicing. Do not mix synthetic oil with other types of oil.

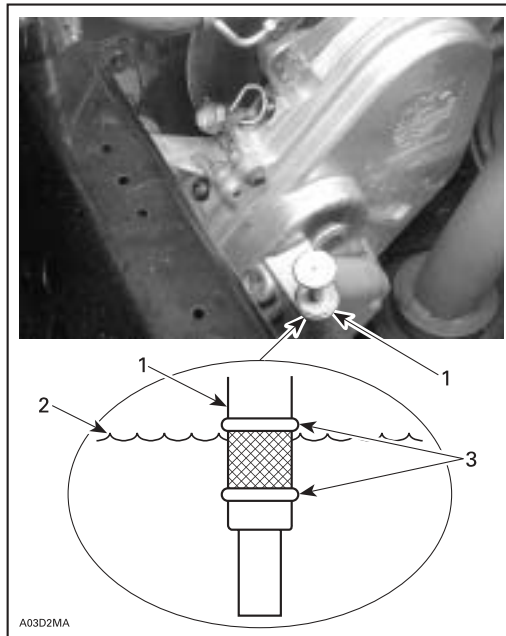

1. Dipstick
2. Oil level
3. Level between marks

## Gear box models

To check, pull dipstick. Oil should reach level mark.

**NOTE:** Before initial start-up, the oil level may be higher than the full mark. After first outing, oil level will decrease as the upper oil cavity fills with oil.

**NOTE:** Do not use unrecommended other types of oil when servicing. Do not mix this synthetic oil with other types of oil.

## Gearbox models

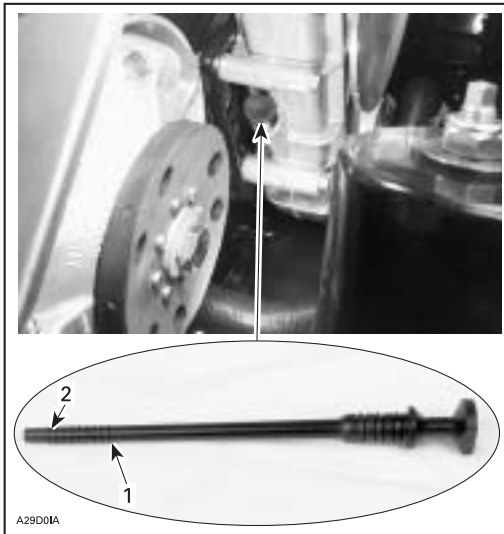

1. Full level mark
2. Lower level mark

## Engine oil level

### 4-Tec models

Make sure engine is at operating temperature. Snowmobile must be on a level surface. Leave engine running at idle for 30 seconds. Stop engine and wipe the dipstick. Dipstick must be completely screwed in before checking oil level. Oil level must be between minimum and maximum marks on dipstick.

## INJECTION OIL SYSTEM

Always maintain a sufficient amount of recommended injection oil in the injection oil reservoir.

**NOTE:** Never allow oil reservoir to be almost empty.

### **WARNING!**

Check level and refill every time you refuel. Wipe off any spillage. Oil is highly flammable when heated.



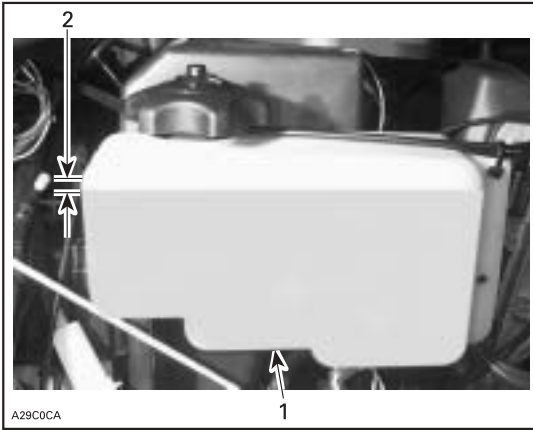

A29C0CA

1. Injection oil reservoir
2. Maximum level: 13 mm from top

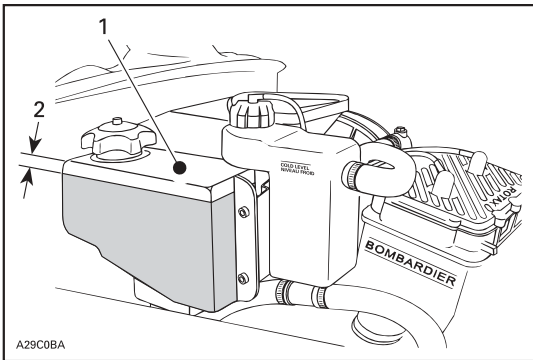

A29C0BA

1. Injection oil reservoir
2. Maximum level: 13 mm from top

#### 4-Tec engine oil

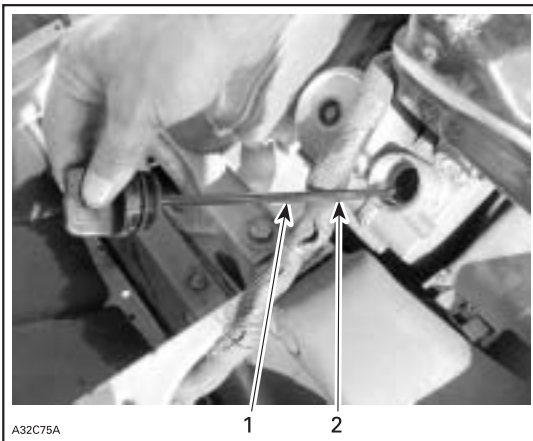

A32C75A

1. Maximum
2. Minimum

There is a capacity of 0,5 L between the two marks.

Add Bombardierin synthetic oil OW40 through dipstick hole as required.

## Cooling system

Check coolant level at room temperature. Liquid should be at COLD LEVEL line (engine cold) of coolant tank.

**NOTE:** When checking level at low temperature it may be slightly lower than mark.

If additional coolant is necessary or if entire system has to be refilled, refer to an authorized Lynx dealer.

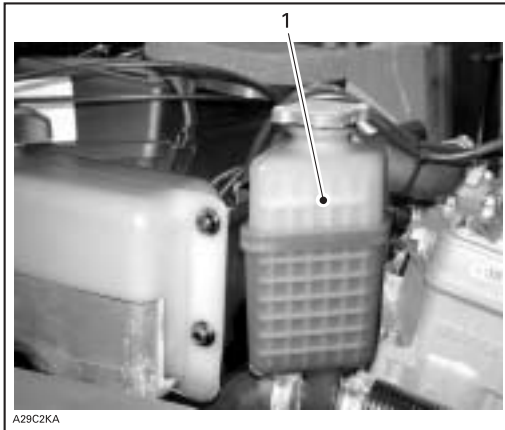

1. COLD LEVEL line

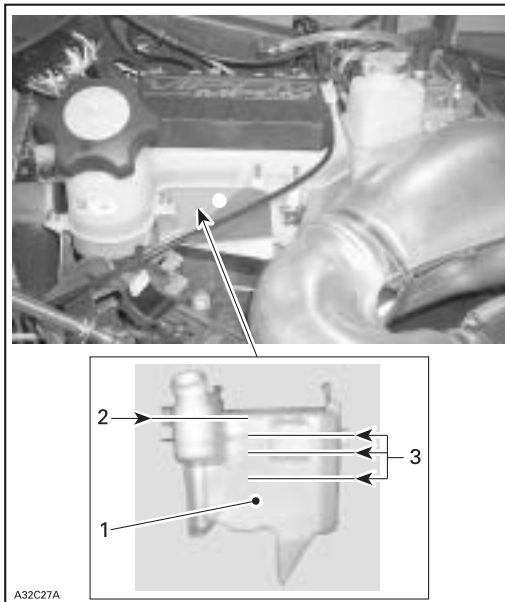

1. Injection oil reservoir
2. Maximum level indicator: 13 mm from top
3. Level marks

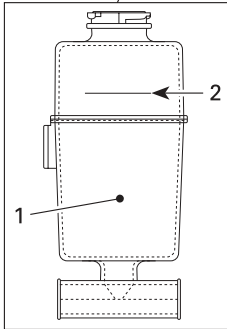
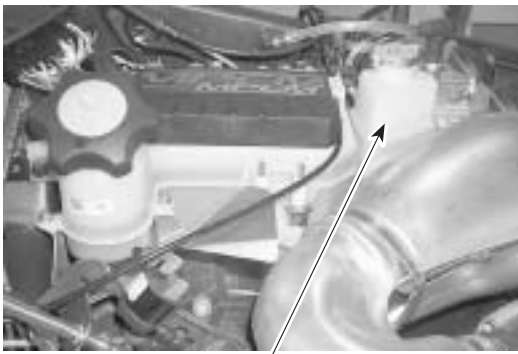

A32C29A

- 1. Coolant tank
- 2. COLD LEVEL line

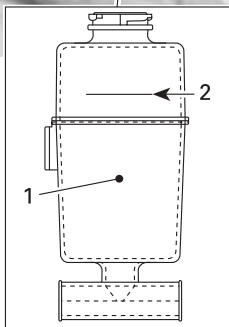
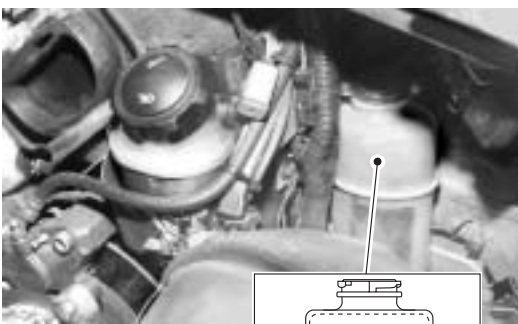

A33C03A

- 1. Coolant tank
- 2. COLD LEVEL line

# BATTERY

## Removal

### WARNING!

Battery BLACK negative cable must always be disconnected first and connected last.

### WARNING!

Never charge or boost battery while installed. Battery electrolyte contains sulfuric acid which is corrosive and poisonous. In case of contact with skin, flush with water and call a physician immediately.

### WARNING!

Should the battery casing be damaged, wear a suitable pair of non-absorbent gloves when removing the battery by hand.

### WARNING!

Battery caps have do not have vent holes. Make sure that vent tube is not obstructed.

**CAUTION:** Should any electrolyte spillage occur, immediately wash off with a solution of baking soda and water to prevent damage to vehicle components.

## Dry battery

These batteries are maintenance-free battery. Electrolyte level can not be checked.

**NOTE:** During the summer storage the battery (also dry battery) has to be charged at least once a month. Otherwise the battery does not work or cannot be recharged in the beginning of season.

## MAINTENANCE

Vehicle cleaning and protection

Remove any dirt or rust.

To clean the entire vehicle, use only flannel cloths or equivalent.

**CAUTION:** It is necessary to use flannel cloths or equivalent on windshield and hood to avoid damaging further surfaces to clean.

To clean the entire vehicle, including bottom pan and metallic parts use Bombardier Cleaner (P/N 293 110 001) spray can 400 g and (P/N 293 110 002 (4 L)).

**CAUTION:** Do not use Bombardier Cleaner on decals or vinyl.

For vinyl and plastic parts use Vinyl & Plastic Cleaner (P/N 413 711 200 (6 x 1 L)).

To remove scratches on windshield or hood use BOMBARDIER Scratch Remover Kit (P/N 861 774 800).

**CAUTION:** Never clean plastic parts or hood with strong detergent, degreasing agent, paint thinner, acetone, products containing chlorine, etc.

Clean sheaves of both pulleys using BOMBARDIER Pulley flange cleaner (P/N 413 711 809).

Inspect the hood and repair any damage.

Touch up all metal spots where paint has been scratched off. Spray all metal parts including shock chromed rods with BOMBARDIER LUBE (P/N 293 600 016).

Wax the hood and the painted portion of the frame for better protection.

**NOTE:** Apply wax on glossy finish only. Protect the vehicle with a cover to prevent dust accumulation during storage.

**CAUTION:** The snowmobile has to be stored in a cold and dry place and covered with an opaque tarpaulin. This will prevent sun rays from affecting vehicle finish.

Lift rear of vehicle until track is off the ground. Install on a mechanical stand.

**NOTE:** Do not release track tension.

### Drive belt removal and installation

#### All models

1. Remove tether cord cap. Open engine compartment.

#### 4-Tec models only

2. Remove air silencer access panel

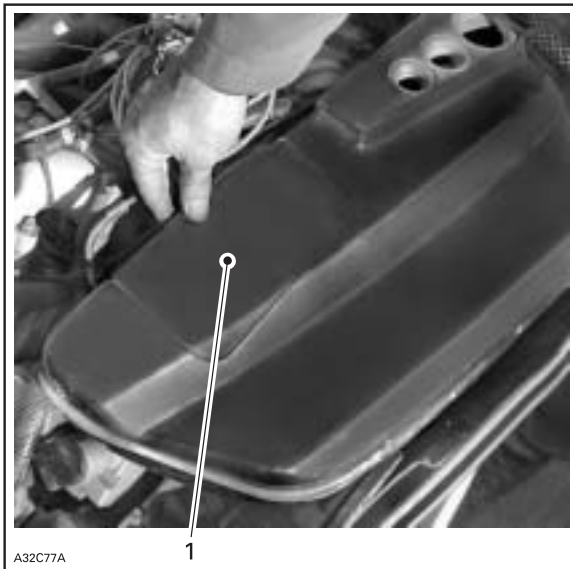

A32C77A

1

1. Access panel

3. Loosen collar screw on air silencer grommet.
4. Disconnect engine vent hose from air silencer.

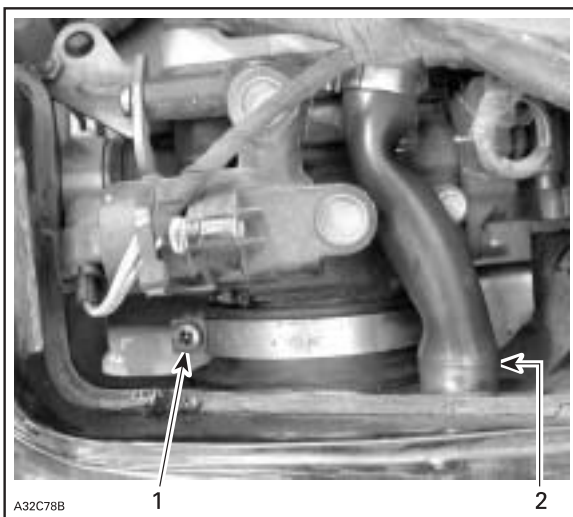

A32C78B

1

2

1. Collar screw  
2. Engine vent hose

5. Disconnect air temperature sensor at rear of air silencer.

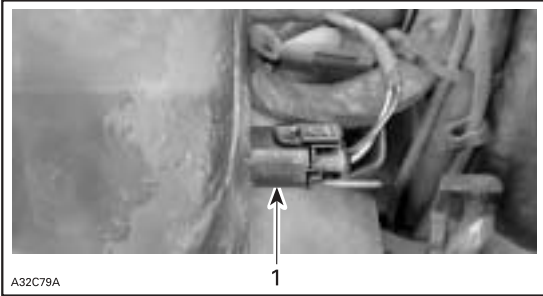

1. Air temperature sensor

### Other models

At reinstallation do not forget to connect air temperature sensor otherwise a trouble code will appear.

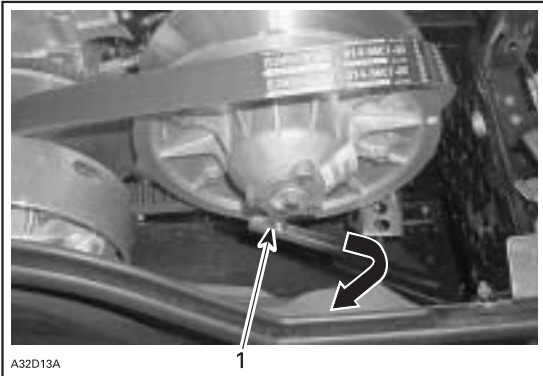

1. Tighten to open pulley

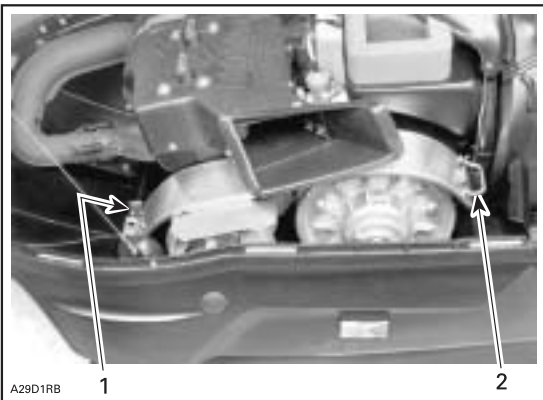

1. Guard  
2. Retaining pins

Stop engine using tether cord.

Open hood. Pull out clip then, open pin retainer. Remove belt guard.

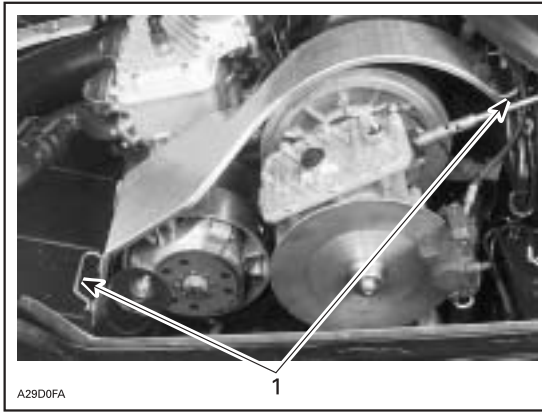

1. Pin retaining

Screw tool in the threaded hole and tighten to open the pulley. Remove belt.

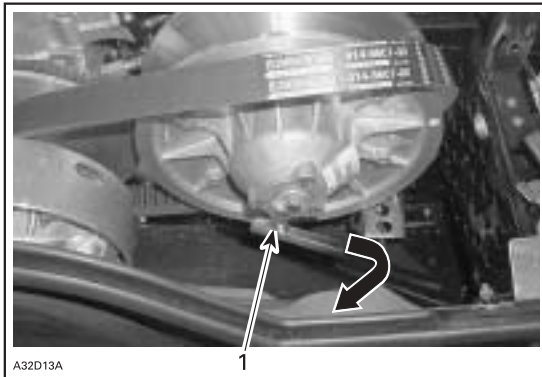

1. Tighten to open pulley

Slip the belt over the top edge of the sliding half, as shown.

### All models

When reinstalling belt guard, position its cut-away toward front of snowmobile. Refer to decal in belt guard.

**NOTE:** Belt guard is purposely made slightly oversize to maintain tension on its pins and retainers preventing undue noise and vibration. It is important that this tension be maintained when reinstalling.



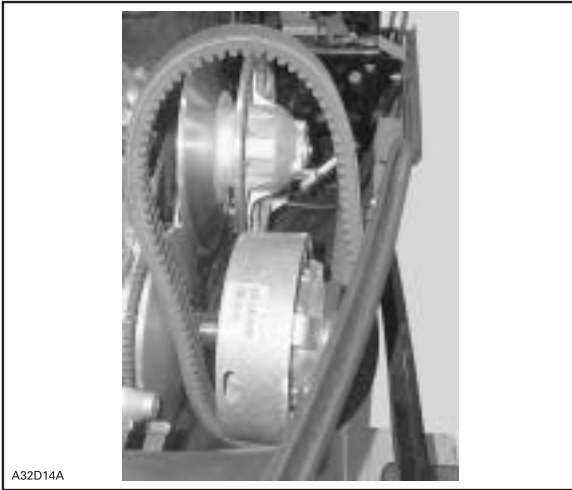

A32D14A

TYPICAL

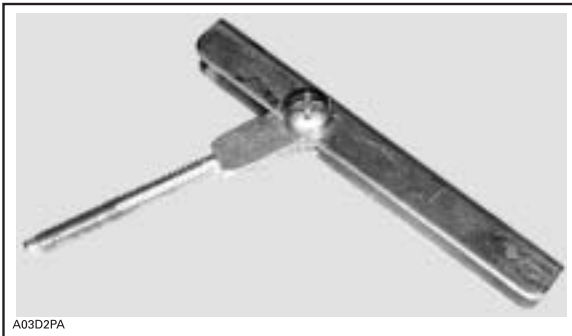

A03D2PA

DRIVE BELT INSTALLER/ REMOVER

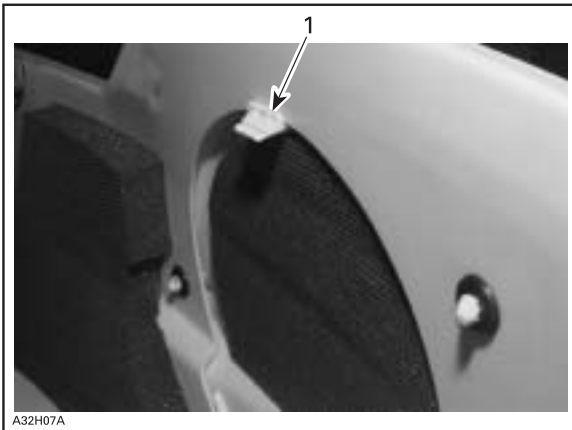

A32H07A

1. Push tab down and pull panel out of bottom pan

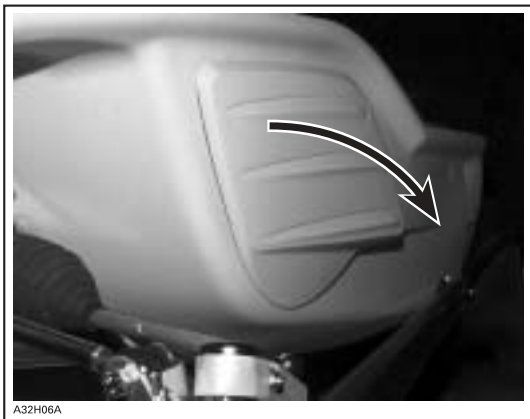

PULL PANEL OUT OF BOTTOM PAN

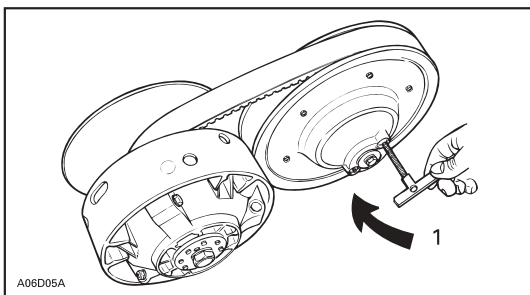

1. Tighten to open pulley

Turn sliding half clockwise then, pull on drive belt to open driven pulley. Follow instruction on decals for belt removal and installation.

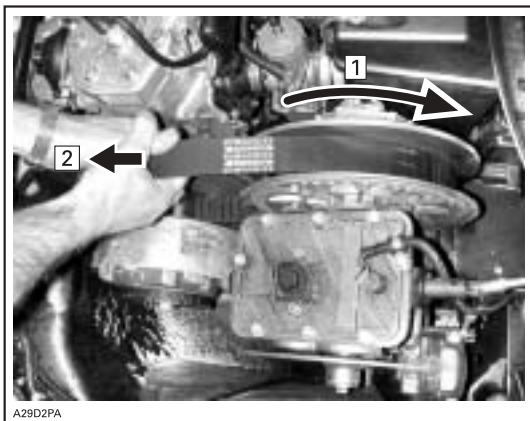

1. Turn sliding half clockwise  
2. Pull belt to open driven pulley

## All models

Slip the belt over the top edge of the sliding half, as shown.

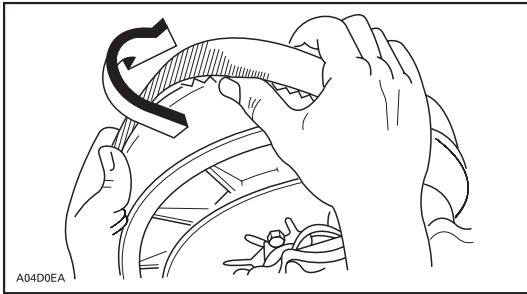

## Installation

### All models

The maximum drive belt life span is obtained when the belt has the proper rotation direction. Install it so the arrow printed on belt is pointing at front of vehicle.

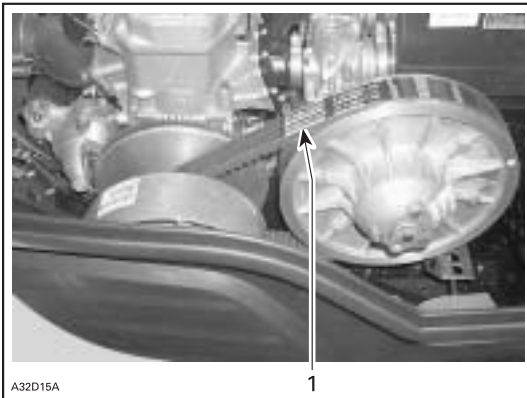

1. Arrow pointing at front of vehicle

**CAUTION:** Do not force or use tools to pry the belt into place, as this could cut or break the cords in the belt.

Clean sheaves of both pulleys using BOMBARDIER Parts Cleaner (P/N 413 711 809).

### All models

To install the drive belt, first place belt between drive pulley sheaves. Then, between driven pulley sheaves, finishing with bottom.

Follow instructions on belt guard.

Reinstall belt guard.

### Drive chain tension

**Chain case models :** Remove hair pin.

Fully tighten tensioner adjustment screw by hand, then back off only far enough for hair pin to engage in locking hole.

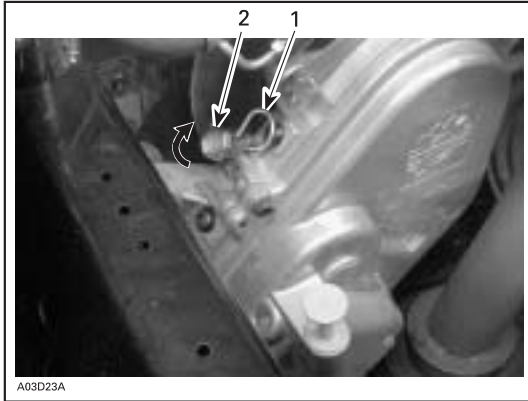

1. *Hair pin*
2. *Adjustment screw*

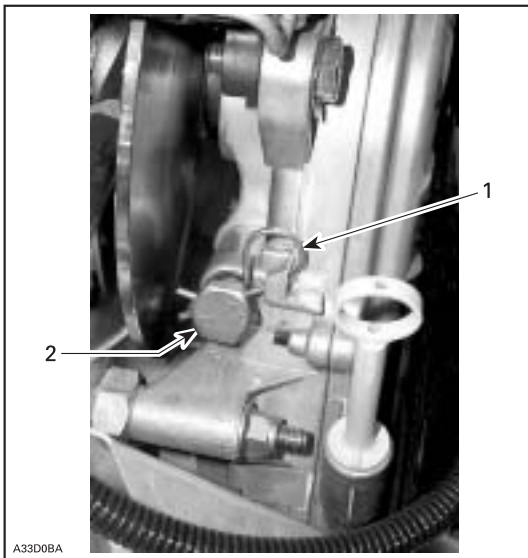

1. *Hair pin*
2. *Adjustment screw*

## TRA I Drive pulley adjustment

### All models except 4-Tec models

The drive pulley is factory calibrated to transmit maximum engine power at a predefined RPM. refer to TECHNICAL DATA at the end of this guide. Factors such as ambient temperature, altitude or surface condition may vary this critical engine RPM thus affecting snowmobile efficiency.

Calibration screws should be adjusted so that actual maximum engine RPM in vehicle matches with the maximum horsepower RPM.

**NOTE** Use precision digital tachometer for engine RPM adjustment.

**NOTE:** The adjustment has an effect on high RPM only.

To adjust, turn calibration screws.

**CAUTION!** Exceeding the engine RPM results to engine damage. Follow the adjustment sets according technical data.

Calibration screw has a notch on top of its head. There are 6 positions numbered 1 to 6.

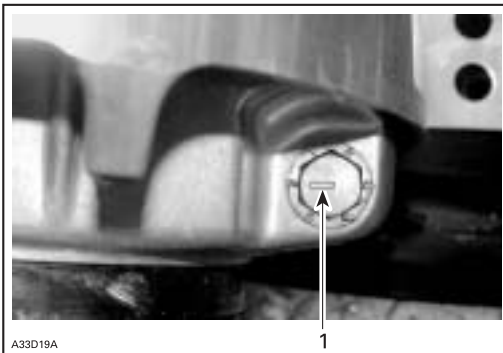

1. Notch

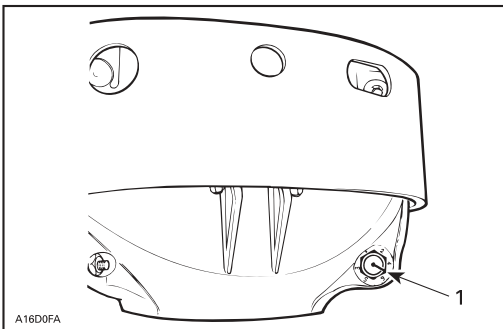

1. Notch

There are 6 positions numbered 1 to 6. Note that in position 1 the number is substituted by a dot (due to its location on casting).

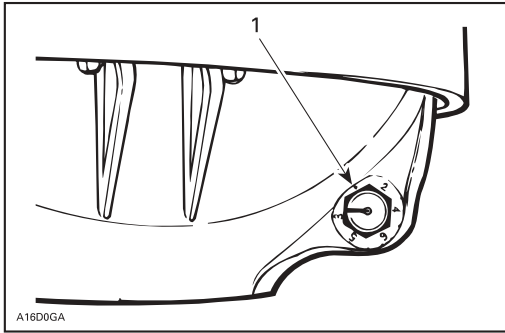

*TRA drive pulley*

*1. Position 1 (not numbered)*

Lower position numbers decrease engine RPM in steps of 200 RPM and higher position numbers increase it in steps of 200 RPM.

**EXAMPLE:** Calibration screw is set at position 4 and is changed to position 6 : So maximum engine RPM is increased by 400 RPM.

#### **4-Tec models:**

From factory TRA drive pulley adjustment screws are set to position 3. This position allows the best compromise between acceleration, top speed and fuel economy.

Position 1 or 2 would provide the best fuel economy. Top speed would be reduced.

Position 4 would give the best acceleration. Fuel economy would be reduced.

Adjust as follows: (only if calibrations are changed)

Loosen locking nut enough to pull calibration screw partially out and adjust to desired position. Do not completely remove the locking nut. Torque nut to 10 Nm.

**CAUTION:** Do not completely remove calibration screw otherwise inside washer will fall off. Always adjust all 3 calibration screws and make sure they are all set at the same number.

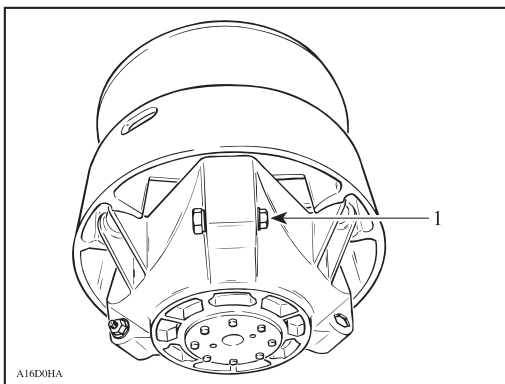

*1. Loosen just enough to permit rotating of calibrate screw*

## WARNING!

Always reinstall belt guard. Do not operate engine with hood open or belt guard removed. Improper servicing, modification or poor adjustment may affect drive pulley performance and belt life. Refer to an authorized Lynx dealer.

### Drive belt condition

Inspect belt for cracks, fraying or abnormal wear (uneven wear, wear on one side, missing cogs, cracked fabric). If abnormal wear is noted, probable cause could be pulley misalignment, excessive RPM with frozen track, fast starts without warm-up period, burred or rusty sheave, oil on belt or distorted spare belt. Contact an authorized Lynx dealer.

Check the drive belt width. Replace the drive belt if width is less than the minimum width recommended in TECHNICAL DATA.

### Brake condition

## WARNING!

The brake mechanism on your snowmobile is an essential safety device. Keep this mechanism in proper working condition. Above all, do not operate the snowmobile without an effective brake system. Periodically verify the condition/wear of the brake pads.

### Brake adjustment

#### Mechanical brake

The brake mechanism is self-adjusting type.

#### Hydraulic brake

No adjustment is provided for hydraulic brake. See an authorized Lynx dealer if any problems.

### Rear suspension condition

Visually inspect all suspension components including slider shoes, springs, wheels, etc.

**NOTE:** During normal driving, snow will act as a lubricant and coolant for the slider shoes. Extensive riding on ice or sanded snow, will create excessive heat build-up and cause premature slider shoe wear

## Suspension stopper strap condition

Inspect stopper strap for wear and cracks, bolt and nut for tightness. If loose inspect holes for deformation. Replace as required. Torque nut to 7 Nm.

## Track condition

Lift the rear of the snowmobile and support it with a wide-base snowmobile mechanical stand. Rotate the track by hand, and inspect condition. If worn or cut, or if track fibers are exposed, or if missing or defective inserts or guides are noted, contact an authorized Lynx dealer.

### WARNING!

Do not operate or rotate track if torn, damaged or excessively worn.

## Track tension and alignment

Ride the snowmobile in snow about 15 to 20 minutes prior to adjusting track tension.

Lift rear of snowmobile and support it with a wide-base snowmobile mechanical stand.

Allow the suspension to extend normally and check the gap half-way between front and rear idler wheels. Measure between slider shoe bottom and inside of track. The gap should be as given in TECHNICAL DATA.

### WARNING!

Track tension must be as describe in technical data. Too loose track may cause an accident.

**IMPORTANT:** Too much tension will result in power loss and excessive stresses on suspension components.

To adjust track tension:

Remove idler wheel cover. Loosen rear idler wheel fastening screws. Turn adjustment screws if required. If correct tension is unattainable, contact an authorized Lynx dealer.

### WARNING!

Do not try to check the tension with engine on. Turn ignition switch to OFF. Do not touch rotating track, it may cause injuries.



## Alignment

### WARNING!

Before checking track alignment, ensure that the track is free of all particles which could be thrown out while track is rotating. Keep hands, tools and clothing clear of track.

Start the engine and accelerate slightly so that track barely turns. This must be done in a short period of time (15 to 20 seconds). Check that the track is well centered.

Check that the track is well centered; equal distance on both sides between edges of track guides and slider shoes.

Stop engine prior to adjusting. Loosen rear idler wheel retaining screws. Tighten the adjustment screw on side where the slider shoe is the farthest from the track insert guides.

Tighten lock nuts and retaining screws.

### WARNING!

Tighten the nuts properly. If lock nuts or adjustment screws are not tightened properly, the track may become loose and get damaged.

Restart engine and rotate track slowly to recheck alignment.

Reposition snowmobile on ground.

**NOTE:** A belt tension tester (P/N 414 348 200) may be used to measure deflection as well as force applied.

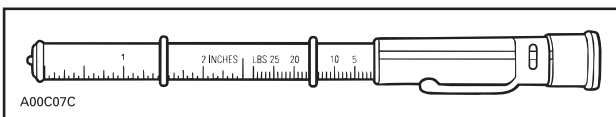

*BELT TENSION TESTER*

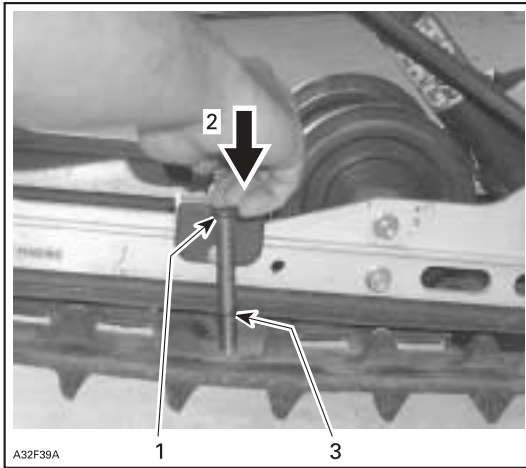

1. Top tool O-ring positioned at 7,3 kg
2. Push on top portion of tool until it contacts the top O-ring
3. Measured track deflection

## STEERING AND FRONT SUSPENSION MECHANISM

Visually inspect steering and front suspension mechanism for tightness of components (steering arms, control arms and links, tie rods, ball joints, ski coupler bolts, etc.) If necessary, contact an authorized Lynx dealer.

### Wear and condition of skis and runners

Check the condition of the skis, ski runners and ski runner carbides. If worn, contact an authorized Lynx dealer.

### **WARNING!**

Excessively worn skis and/or ski runners will affect snowmobile control.

## EXHAUST SYSTEM

The exhaust system is designed to reduce noise and to improve the total performance of the engine. If any exhaust system component is removed, modified or damaged, severe engine damage may result.

## AIR FILTER CLEANING

### Some models

While riding in deep powder snow, periodically stop then shake the snow from the filter. Check that air silencer is clean and dry and properly reinstall the filter.

Leaving the snowmobile uncovered during a snowfall or riding in deep powder snow may block air filter and choke the engine. Open the hood, remove the air filter out of air silencer, shake the snow from filter and properly reinstall the filter.



*REMOVAL OF FILTER FROM ITS GRILL*

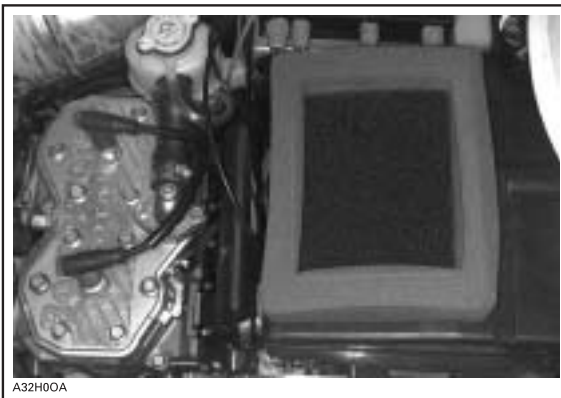

*SECONDARY FILTER INSTALLED ON AIR SILENCER*

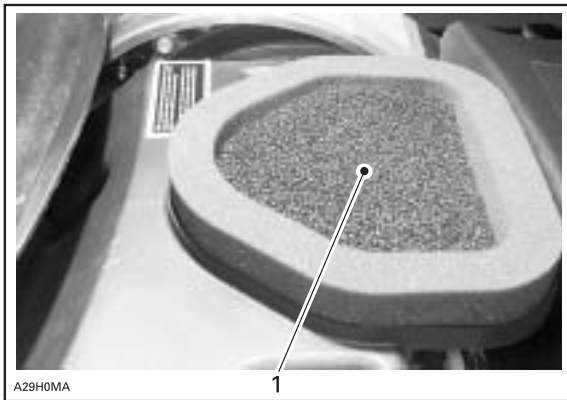

*1. Air filter installed on top of air silencer*



### *AIR FILTER POSITIONING*



### *REMOVING FILTER OF ITS GRILL*

Check that the air silencer is clean and dry and properly reinstall the filter.

**CAUTION:** Snowmobile have been calibrated with the filter installed. Operating the snowmobile without it may cause engine damage.

## BULB REPLACEMENT

Always check light operation after bulb replacement.

**CAUTION:** Never touch glass portion of an halogen bulb with bare fingers, it shortens its operating life. If glass is touched, clean it with isopropyl alcohol which will not leave a film on the bulb.

### Some models

If headlamp bulb is burnt: Remove headlight moulding and windshield, unplug the connector from the bulb, remove the protector cap and bulb retainer clips. Install new headlamp bulb.

### Some models

If the headlamp bulb is burnt: Remove windshield and headlamp moulding, unplug connector from headlamp, remove protector cap and turn bulb off, install new headlamp bulb.

## INSTRUMENTS

Bulb socket is always behind the instrument under a black rubber boot. Pull rubber boot and pull bulb out of socket.

### Headlamp beam aiming

Turn knob to adjust beam height.

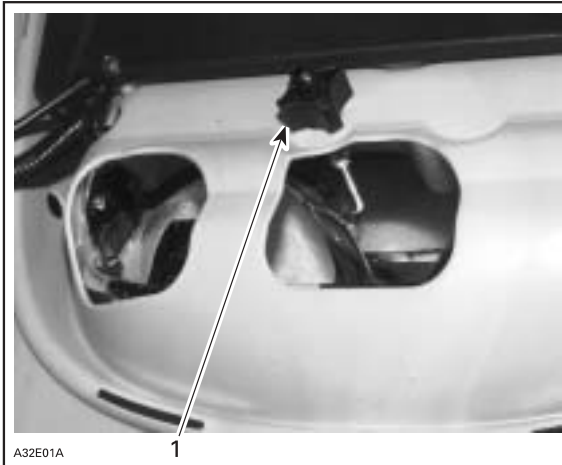

1. Knob

If any headlamp bulb is burnt, remove windshield and unplug burnt bulb connector. Remove the rubber boot.

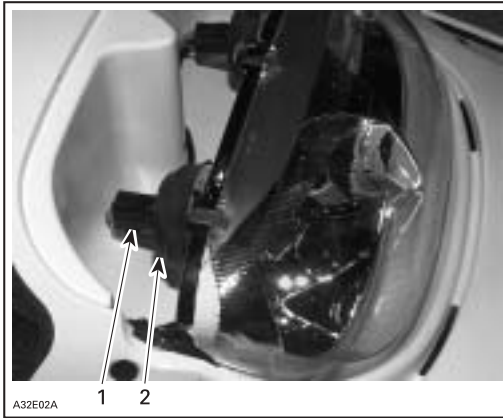

1. Bulb connector
2. Rubber boot

Turn bulb locking ring counterclockwise to remove it. Detach the bulb and replace. Properly reinstall parts.

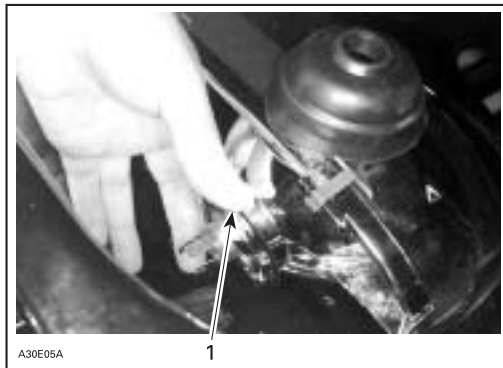

1. Locking ring

Unplug burnt bulb connector. Remove the rubber boot.

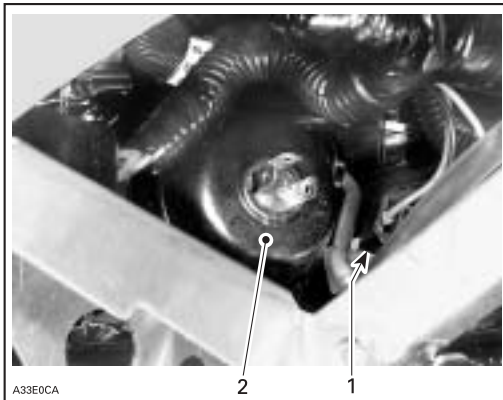

1. Bulb connector
2. Rubber boot

Turn bulb locking ring counterclockwise to remove it. Detach the bulb and replace. Properly reinstall parts.

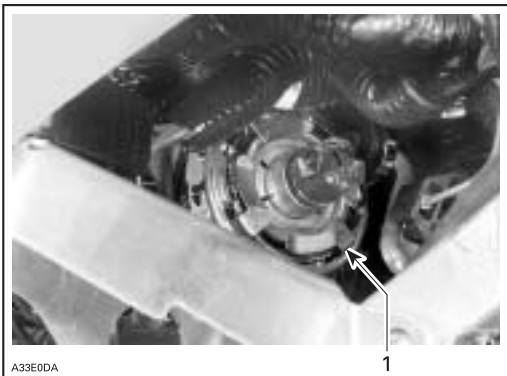

1 Locking ring

If taillight bulb is burnt, expose the bulb by removing the red plastic lens. To remove, unscrew the 2 lens screws.

## STORAGE

It is during summer, or when a snowmobile is not in use for more than one month that proper storage is a necessity.

### WARNING!

Do not storage snowmobile in open sunny place. Plastic cover is not recommended; it may get wet and causes rust.

## REAR GRAB HANDLES

### Some models

Rear grab handles provides a grip for the passenger.

Rear grab handle height can be adjusted.

Lift up adjustment lock, move rear grab handle to desired position. Fasten adjustment lock. Proceed same on opposite side.

### Adjustable backrest

### Some models

The backrest position and support angle may be adjusted to suit driver or passenger convenience.

## TROUBLESHOOTING

### Monitoring beeper coded signals:

CODED SIGNAL	POSSIBLE CAUSE	REMEDY
2 short beeps (when engine is started). DESS/RER pilot lamp also blinks.	Confirms that proper tether cord cap is installed.	Normal condition.
1 short beep every 1,5 seconds (when engine is started). DESS/RER pilot lamp also blinks. Engine cannot reach engagement speed. Vehicle cannot be driven.	Bad DESS system connection. Defective tether cord cap. Dirt or snow in tether cord cap. Defective DESS post.	Reinstall tether cord cap correctly over post. Use another programmed tether cord cap. Clean tether cord cap. Contact an authorized Lynx dealer.
1 long beep per second	Reverse is selected	Vehicle can be driven in reverse
3 short beeps per second. DESS/RER pilot lamp also blinks. Engine cannot reach pulley engagement. Vehicle cannot be driven.	Wrong tether cord cap is installed	Install proper tether cord cap.
3 short beeps per second. Engine overheating pilot lamp also blinks.	Engine is overheating	Stop engine immediately and allow to cool. If trouble persists, see an authorized Lynx dealer.
3 short beeps per second. Oil pilot lamp also lights up.	Low oil pressure on 4 –tec models.	Stop engine immediately and allow to cool. If trouble persists, see an authorized Lynx dealer.
3 short beeps per second. Battery pilot lamp also lights up.	Low battery voltage	Check battery and charging system, see an authorized Lynx dealer.
4 short beeps every 2 minutes. Oil pilot lamp also lights up.	Low oil level on 2 –tec models.	Check oil level and add oil as soon as possible.



<b>CODED SIGNAL</b>	<b>POSSIBLE CAUSE</b>	<b>REMEDY</b>
4 short beeps every 2 minutes. Engine pilot lamp also lights every 3 seconds.	Too high battery voltage. DESS system has detected a shorted key installed on DESS post.	Use another programmed tether cord cap.
4 short beeps every 2 minutes. Engine pilot lamp also lights up.	Defect in engine management system. (EMS)	See an authorized Lynx dealer.
4 short beeps every 2 minutes. Engine pilot lamp blinks every 1 second.	Defect in engine management system. (EMS)	See an authorized Lynx dealer.

<b>TROUBLESHOOTING</b>	
<b>SYMPTON: Engine turns over but fails to start</b>	
<b>POSSIBLE CAUSES</b>	<b>WHAT TO DO</b>
Ignition switch, engine cut-out switch or tether cord is OFF position.	Place all the switches to ON position.
Mixture not rich enough to start cold engine.	Check fuel tank and check starting procedure, particularly use of the choke or primer.
Flooded engine (spark plug wet when removed).	Do not choke. Remove wet spark plug, turn ignition switch to OFF and crank engine several times. Install clean, dry spark plug. Start engine following usual starting procedure. If engine continues to flood, see an authorized Lynx dealer.
No fuel to the engine (spark plug dry when removed).	Check fuel tank level; turn fuel valve on if applicable; check fuel filter; replace if clogged; check condition of fuel and impulse lines and their connections. A failure of the fuel pump or carburetor has occurred; contact an authorized Lynx dealer.
Spark plug/ignition (no spark).	Remove spark plug (s) then reconnect to spark cap. Check that engine cut-out switch is at the ON position and the tether cut-out cord cap is snapped over the receptacle. Start engine with spark plug (s) grounded to engine away from spark plug hole. If trouble persists, contact an authorized Lynx dealer.

Engine compression.	As the engine is pulled over with the rewind starter, "cycles" of resistance should be felt as piston goes past top dead center (each piston on multi-cylinder engines). If no pulsating resistance is felt, it suggests a major loss of compression. Contact an authorized Lynx dealer.
---------------------	--

<b>SYMPTON: Engine lacks acceleration or power</b>	
<b>POSSIBLE CAUSES</b>	<b>WHAT TO DO</b>
Fouled or defective spark plug	Check item "Engine turns over but fails to start"
Lack of fuel to engine	See item "Engine turns over but fails to start"
Carburetor adjustments	Contact an authorized Lynx dealer.
Drive belt worn too thin	If the drive belt has lost more than 3 mm of its original width, it will affect vehicle performance.
Drive and driven pulleys require servicing	Contact an authorized Lynx dealer.
Engine is overheating	On liquid cooled engines: Check coolant level, pressure cap, thermostat and for air locks in cooling system. On fan cooled engines: Check fan belt and its tension; clean cooling fins of engine; if overheating persists, contact an authorized Lynx dealer.

<b>SYMPTON: Engine backfires</b>	
<b>POSSIBLE CAUSES</b>	<b>WHAT TO DO</b>
Faulty spark plug	See item "Engine turns over but fails to start"
Engine is running too hot	See item "Engine lacks acceleration or power"
Ignition timing is incorrect or there is an ignition system failure	Contact an authorized Lynx dealer

SYMPTON: Engine misfires	
POSSIBLE CAUSES	WHAT TO DO
Fouled/defective/worn spark plug	Clean/verify spark plug gap and identification number. Replace as required.
Too much oil supplied in engine	Improper oil pump adjustment, refer to an authorized Lynx dealer. Too rich fuel/oil mixture (only during break-in period). Drain fuel tank and refill with appropriate mixture ratio.
Water in fuel	Drain fuel system and refill with fresh fuel. Replace fuel filter if needed.

SYMPTOM: Snowmobile cannot reach full speed	
POSSIBLE CAUSES	WHAT TO DO
Drive belt	Check item "Engine lacks acceleration or power"
Incorrect track adjustment	See MAINTENANCE or an authorized Lynx dealer for proper alignment and tension adjustments.
Pulleys misaligned	Contact an authorized Lynx dealer.
Engine	See item "Engine lacks acceleration or power".

TECHNICAL DATA 2004		6900 FCE	ST 600	GLX ST 550 F	GLX 5900 FCE	59 YETI	FOREST FOX
Engine Max.power kW	RPM	42/7000	66/8000	42/7000	37/6800	7000	23/6750
Spark plug Type Gap	NGK mm	BR9ES 0,45	BR9ECS 0,45	BR9ES 0,45	BR9ES 0,45	DCPR8E 07-08	BR9ES 0,45
Track Width x length (mm) Tension 1) (mm)	mm mm	600x3968 40-50	500x3968 40-50	500x3968 40-50	500x3968 40-50	500x3968 40-50	380x3968 40-50
Fluids Gas Oil type Oil type gearbox Liquid-water solution	RON OCT  	98E  SAE 75W-140 API	98E  GL5 Hypoid S	98E  SAE 75W-140 API	98E  SAE 75W-140 API	95E  GL5 Hypoid S	98E  -
Volumes Gas tank Oil tank Liquid volume Oil volume gearb.	     	42 2,5 - 0,4	42 2,5 4 0,4	42 2,5 - 0,4	42 2,5 - 0,4	38 - - 0,4	37 2,5 - 0,4
Thermostat Fan belt Drive belt Headlight Taillight Brakelight	°C mm mm W W W	- 10x610 35x1118 H4 60/55 5 21	42 - 38x1126 2 x H4 60/55 5 21	- 10x610 35x1118 2 x H4 60/55 5 21	- 10x610 35x1118 2 x H4 60/55 5 21	- - 38x1180 H4 60/55 5 21	- 10x610 35x1118 H4 60/55 5 21

1) Measure gap between slider shoe and bottom inside of track when exerting a downward pull of 7,3 kg to the track.

TECHNICAL DATA 2004		RAVE 800 SPECIAL	ENDURO 600 SP	ENDURO 500 SP	ENDURO 400 F	ENDURO 550 F	RACING	SPORT TOURING 800
<b>Engine</b>								
Max.power kW/RPM		101/8000	85/8100	66/8000	35,5/7300	49/7000	69/8500	95/7800
<b>Spark plug</b>								
Type	NGK	BR9ECS	BR9ECS	BR9ECS	BR9ES	BR9ES	BR9ECS	BR9ECS
Gap	mm	0,45	0,45	0,45	0,45	0,45	0,45	0,45
<b>Track</b>								
Width x length	mm	380x3070 (30)	380x3070 (30)	380x3070 (30)	380x3070	380x3070	380x3070 (38)	380x3456 (31,8)
Tension <sup>1)</sup>	mm	20-25	20-25	20-25	30-35	30-35	20-25	30-35
<b>Fluids</b>								
Gas	RON OCT	95E	95E	95E	*98E+1%	98E	98E + 4%	95E
Oil type	BOMBARDIER-ROTAX INJECTION OIL							BOMBARDIER-ROTAX / INJ.OIL
Oil type gearb.	SAE 75W-140 API GL5 Hypoid S			SAE 75W-140 API GL5 Hypoid S			SAE 75W-140 API GL5 Hypoid S	
Liquid-water solution	l	50/50	50/50	50/50	-	-	50/50	50/50
<b>Volumes</b>								
Gas tank	l	38	38	38	38	38	38	38
Oil tank	l	3,5	3,5	3,5	3,5	3,5	-	3,5
Liquid volume	l	3,9	3,9	3,9	-	-	3,9	4,2
Oil volume gearb.	l	0,25	0,25	0,25	0,25	0,25	0,25	0,25
Thermostat	°C	42	42	42	-	-	42	42
Fan belt	mm	-	-	-	10x610	10x610	-	-
Drive belt	mm	37,6x1118	36,6x 1097	35,3x1108	35,3x1108	35,3x1108	35,3x1108	37,3x1118
Headlight	W	2 x H4 60/55	2 x H4 60/55	2 x H4 60/55	2 x H4 60/55	2 x H4 60/55	2 x H4 60/55	2 x H4 60/55
Taillight	W	5	5	5	5	5	5	5
Brake light	W	21	21	21	21	21	21	21

1) Measure gap between slider shoe and bottom inside of track when exerting a downward pull of 7,3 kg to the track.

\* 1% fuel-oil mixture also in fuel tank

TECHNICAL DATA 2004	SPORT TOURING 600	RANGER FCE	RANGER LCE 600	RANGER MOUNTAIN 800	RANGER 4-tec	EXPLORER 550 F	SAFARI 400 F
<b>Engine</b>							
Max.power kW/RPM	85/8100	41/6750	76/8000	103/7950	60/7000	42/7000	27/7000
<b>Spark plug</b>							
Type	BR9ECS	BR9ES	BR9ECS	BR9ECS	DCPR8E	BR9ES	BR9ES
Gap	0,45	0,45	0,5	0,5	0,7-0,8	0,45	0,45
<b>Track</b>							
Width x length	380x3456 (31,8)	380x3968	380x3968	380x3648 (50,8)	380x3968 (25,4)	380x3456	380x3456
Tension 1)	30-35	35-40	35-40	35-40	35-40	45-50	45-50
<b>Fluids</b>							
Gas	95E	95E	95E	98E	95E	95E	95E
Oil type	J.OIL		BOMBARDIER-RO	BOMBARDIER-ROTAX	INJ.OIL		
Oil type gearb.			SAE 75W-140	SAE 75W-140	API GL5 Hypoidi S		
Liquid-water solution	50/50	-	50/50	50/50	50/50	-	-
<b>Volumes</b>							
Gas tank	38	38	38	38	38	38	38
Oil tank	3,5	3,5	3,5	3,5	3,5	3,5	3,5
Liquid volume	4,2	-	4,2	4,2	4,2	-	-
Oil volume gearb.	0,25	0,25	0,4	0,25	0,25	0,25	0,25
Thermostat	42	-	42	42	80	-	-
Fan belt	-	10x610	-	-	-	10x610	10x610
Drive belt	36,6x1097	35,3x1108	35,3x1108	35,3x1118	37,6x1101	35,3x1108	35,3x1108
Headlight	2 x H4 60/55	2 x H4 60/55	2 x H4 60/55	2 x H4 60/55	2 x H4 60/55	2 x H4 60/55	2 x H4 60/55
Taillight	5	5	5	5	5	5	5
Brake light	21	21	21	21	21	21	21

**Bombardier-Nordtrac Oy**  
*RECREATIONAL PRODUCTS*  
*www.bombardier.fi*

