

can-am



OPERATOR'S GUIDE

Includes Safety, Use and Maintenance Information

2025

WARNING

Learn how the vehicle is different.

Read this operator's guide.

Complete a training course (if available), practice and become proficient with the controls.

Consult local laws - license requirements vary by location.

Keep this operator's guide with the vehicle at all times.

ORIGIN SERIES
Original Instructions

 **WARNING**

Disregarding any of the safety precautions and instructions contained in the Operators's Guide and on product safety labels could cause injury including the possibility of death.

CALIFORNIA PROPOSITION 65 WARNING

 **WARNING**

Operating, servicing and maintaining a passenger vehicle or off-highway motor vehicle can expose you to chemicals including engine exhaust, carbon monoxide, phthalates, and lead, which are known to the State of California to cause cancer and birth defects or other reproductive harm. To minimize exposure, avoid breathing exhaust, do not idle the engine except as necessary, service your vehicle in a well-ventilated area and wear gloves or wash your hands frequently when servicing your vehicle. For more information go to www.p65warnings.ca.gov/products/passenger-vehicle.

 **WARNING**

Battery posts, terminals and related accessories contain lead and lead compounds, which are known to the State of California to cause cancer and birth defects or other reproductive harm. To minimize exposure, wear gloves or wash your hands frequently when servicing your vehicle. For more information, go to www.P65Warnings.ca.gov

Safety Messages

This operator's guide utilizes the following symbols and words to emphasize particular information:

 This is the safety alert symbol. It is used to alert you to potential physical injury hazards. Obey all safety messages that follow this symbol to avoid possible injury or death.

 **DANGER**

Indicates a potential hazard which if not avoided, will result in serious injury or death.

 **WARNING**

Indicates a potential hazard which, if not avoided, could result in serious injury or death.

 **CAUTION**

Indicates a hazard situation which, if not avoided, could result in minor or moderate injury.

NOTICE

Indicates installation, operation, or maintenance information which is important but not hazard-related. In some cases, if not followed, vehicle components or other properties could be severely damaged.

Deutsch	Dieses Handbuch ist möglicherweise in Ihrer Landessprache verfügbar. Bitte wenden Sie sich an Ihren Händler oder besuchen Sie: www.operatorsguides.brp.com
English	This guide may be available in your language. Check with your dealer or go to: www.operatorsguides.brp.com
Español	Es posible que este manual esté disponible en su idioma. Consulte a su distribuidor o visite: www.operatorsguides.brp.com
Français	Ce guide peut être disponible dans votre langue. Vérifier avec votre concessionnaire ou aller à: www.operatorsguides.brp.com
Italiano	Questa guida potrebbe essere disponibile nella propria lingua. Contattare il concessionario o consultare: www.operatorsguides.brp.com
中文	本手册可能有您的语种的翻译版本。请向经销商询问，或者登录 www.operatorsguides.brp.com 查询。
日本語	このガイドは、言語によって翻訳版が用意されています。ディーラーに問い合わせるか、次のアドレスでご確認ください： www.operatorsguides.brp.com
Nederlands	Deze handleiding kan beschikbaar zijn in uw taal. Vraag het aan uw dealer of ga naar: www.operatorsguides.brp.com
Norsk	Denne boken kan finnes tilgjengelig på ditt eget språk. Kontakt din forhandler eller gå til: www.operatorsguides.brp.com
Português	Este manual pode estar disponível em seu idioma. Fale com sua concessionária ou visite o site: www.operatorsguides.brp.com
Русский	Воспользуйтесь руководством на вашем языке. Узнайте о его наличии у дилера или на странице по адресу www.operatorsguides.brp.com
Suomi	Käyttöohjekirja voi olla saatavissa omalla kielelläsi. Tarkista jälleenmyyjältä tai käy osoitteessa: www.operatorsguides.brp.com
Svenska	Denna bok kan finnas tillgänglig på ditt språk. Kontakta din återförsäljare eller gå till: www.operatorsguides.brp.com

<i>Covered Models</i>	<i>Power</i>
Origin	11 kW (continuous, A1 license)
	35 kW (standard)
Origin '73	35 kW (standard)

TABLE OF CONTENTS

GENERAL INFORMATION	1
SAFETY INFORMATION	2
VEHICLE INFORMATION	3
MAINTENANCE	4
TECHNICAL INFORMATION	5
TECHNICAL SPECIFICATIONS	6
TROUBLESHOOTING	7
WARRANTY	8
CUSTOMER INFORMATION	9

1 GENERAL INFORMATION - TABLE OF CONTENTS

GENERAL INFORMATION	1-2
Know Before you Go	1-2
About this Operator's Guide	1-2
Acknowledgment	1-3
Be A Responsible Rider	1-3
Respect of the Environment	1-3

GENERAL INFORMATION

Congratulations on your purchase of a new Can-Am® Electric Motorcycle. It is backed by the Bombardier Recreational Products Inc. (BRP) warranty and a large network of authorized dealers ready to provide the parts, service or accessories you may require.

Your dealer is committed to your satisfaction. He has taken training to prepare, inspect and performed the final adjustment of your new vehicle before you took possession of it.

If you need more information concerning the servicing of your vehicle, please ask your dealer.

At delivery, you were informed about the warranty coverage and also, you signed the *PRE-DELIVERY CHECK LIST* to ensure your new vehicle was prepared to your entire satisfaction.

Know Before you Go

To learn how to reduce the risk for you, your passenger or bystanders being injured or killed, read the following sections before you operate the vehicle:

- *Safety Information*
- *Vehicle Information*

Also read all on-product safety labels on your vehicle, including the electronic safety messages appearing on the multifunction display at vehicle activation.

About this Operator's Guide

This operator's guide has been prepared to acquaint the owner, operator and passenger with this motorcycle and its various controls, maintenance and safe riding instructions.

Keep this Operator's Guide in the vehicle at all time as you can refer to it for operation, instructing others, maintenance and troubleshooting.

Note that this guide is available in several languages. In the event of any discrepancy, the English version shall prevail.

If you want to view and/or print an extra copy of your Operator's Guide, simply visit the following web site:

www.operatorsguides.brp.com

The informations contained in this document are correct at the time of publication. BRP, however, maintains a policy of continuous improvement of its products without imposing upon itself any obligation to install them on products previously manufactured.

Due to late changes, some differences between the manufactured product and the descriptions and/or specifications in this guide may occur. BRP reserves the right at any time to discontinue or change specifications, designs, features, models or equipment without incurring any obligation upon itself.

This operator's guide should remain with the vehicle when it's sold and transferred to the new owner at the time of sale.

Acknowledgment

BRP wishes to thank the Motorcycle Safety Foundation (MSF) for giving permission to BRP to use their material related to street motorcycle safety found in this Operator's Guide.

The MSF is an internationally recognized not for profit foundation and is supported by motorcycle manufacturers. It provides training, tools and partnerships to the motorcycle safety community. Visit its website at:

- www.msf-usa.org

Be A Responsible Rider

At BRP, we believe there's an opportunity for everyone in the powersports and marine communities to come together and rethink how we approach safety, riding etiquette, and the environment. We believe that when we empower all riders to ride responsibly—to look out for each other and safeguard our trails and playgrounds—we inspire an industry to welcome newcomers, build a more caring community and generate positive experiences.

Whether you ride on trails, roads, water or snow, BRP is committed to driving positive change. That's why we're making the Responsible Rider program a key part of our Corporate Social Responsibility initiative through action, education and community empowerment.

To learn more about Responsible Rider, including tips and tricks on safety, riding etiquette and the environment, visit can-am.brp.com/on-road/ca/en/owner-zone/responsible-rider.html#owners

Or, use the following QR code.



Respect of the Environment

The guidelines that we support are not designed to limit your fun, but to preserve the beautiful freedom that you can experience only with an off-road vehicle!

These guidelines will keep operators and passengers healthy, happy and able to introduce others to what they know and enjoy about their favorite pastime. So, the next time you hit the trails, we ask you to remember that you are paving the way for the future of our sport. Help us lead it down the right path! From all of us at BRP, thank you for doing your share.

There is nothing more exhilarating than off-road adventures. Venturing onto trails that cross wild areas is an exciting and healthy sport. However, as the number of people using these recreational parks increases, so does the potential for damage to the environment. Abuse of land, facilities and resources inevitably leads to restrictions and closures of both private and public land.

In essence, the greatest threat to our sport, is all around us. Which leaves us with one logical choice. We must always ride responsibly.

The vast majority respect the law and the environment. Each of us must set an example for those who are new to the sport, young and old alike.

It is in every one's best interest to tread lightly into our recreational areas. Because, in the long run, to protect the sport we must preserve the environment.

Recognizing the importance of this issue and the need for off-road riders to do their share in preserving areas that make it possible to enjoy our sport, BRP invite all off-road riders to remember that respecting the environment is not only critical to the future of our industry but to future generations.

You are a good ambassador for your sport when you follow the principles below.

Become informed. Obtain maps, regulations and other information from the Off-road clubs, the Forest Service or from other public land agencies. Learn the rules and follow them and that goes for speed limits, too!

Avoid running over young trees, shrubs, and grasses and don't cut wood. On flatlands or areas where trail riding is popular, it's important to ride only where authorized. Remember, there is a link between protecting your environment and your own safety.

Respect wildlife and be particularly sensitive of animals that are rearing young or suffering from food shortage. Stress can sap scarce energy reserves. Refrain from riding in areas where only animals are intended to tread!

Obey gate closures and regulatory signs and remember, light treaders don't litter!

Stay out of wilderness areas. They're closed to all vehicles. Know where the boundaries are.

Obtain permission to travel across private land. Respect the rights of landowners and other people's privacy.

Off-road riders know all too well the efforts that have been made throughout the sport's history to enjoy access to areas where people can ride safely and responsibly. This effort continues today, as strong as ever.

Respecting the areas where we ride... wherever they may be... is the principal way to ensure future enjoyment for all.

Take the opportunity to admire nature and all its wonders, is an experience cherished by off-road riders. Respect the nature and wildlife will help our sport to grow!

Finally, you don't have to leave big tracks or careen through a virgin forest to show you can ride. So whether you're driving a high performance BRP off-road vehicle or any other make or model, show you know what you're doing.

2 SAFETY INFORMATION - TABLE OF CONTENTS

BEFORE YOU GO	2-2	Emergency Response	2-19
Operator Age and Ability	2-2	TRANSPORTING THE VEHICLE	2-21
Drugs and Alcohol	2-2	SAFETY INFORMATION ON THE VEHICLE	2-25
Protective Gear	2-2	Important Pre-Ride Safety Message	2-25
Vehicle Condition	2-4	Safety Hang Tag	2-26
Hazardous Materials	2-5	Compliance Hang Tag	2-27
GET FAMILIAR WITH THE MOTORCYCLE	2-6	Safety Labels	2-28
Driving Aid Technologies	2-6	Vehicle Information Hang Tag	2-34
What's Different with a Can-Am Electric Motorcycle	2-7	Vehicle Information Labels	2-35
Carrying Loads	2-8	REPORTING SAFETY DEFECTS	2-37
Accessories and Modifications	2-9	PRE-RIDE INSPECTION	2-38
RIDE SAFELY	2-11	Pre-Ride Checklist	2-38
Plan your Trip	2-11		
Riding Alone	2-11		
Riding in Group	2-12		
Riding with a Passenger	2-12		
Riding with a Trailer	2-13		
Avoiding Collisions	2-13		
Riding Behavior	2-13		
Road Conditions and Hazards	2-13		
Know the Terrain - Off-Road Use	2-15		
Riding Uneven Surfaces	2-17		
In Case of an Accident	2-17		
Tipped Over Vehicle	2-18		
Tire Failure	2-19		

BEFORE YOU GO



Disregarding any of the safety precautions and instructions contained in this section could cause injury including the possibility of death.

Operator Age and Ability

Operators must be qualified, be at least 16 years old and have a valid motorcycle driver's license. Your state, province or country may have additional requirements.

Laws regarding the minimum age and licensing requirements vary from one jurisdiction to another. Be sure to contact the local authorities for information regarding the legal operation of a motorcycle in the intended jurisdiction of use.

BRP highly recommends that you take a motorcycle driving course. Basic training is required for the safe operation of any motorcycle, for on-road and off-road use.

Operation of this motorcycle with a disability that impairs vision, reaction time, judgment, or operation of the controls is not recommended. The safe use of your motorcycle depends on many conditions such as visibility, speed, weather, environment, traffic, vehicle condition and the condition of the operator and passenger.

Drugs and Alcohol

Never ride after consuming alcohol or drugs. Riding on a motorcycle requires the operator and passenger to be sober, attentive and alert. The use of drugs and alcohol, singly or in combination, increases reaction time, impedes judgment, impairs vision and inhibits your ability to safely ride on a motorcycle.

Protective Gear

This section is based on guidance for motorcyclists given by the Motorcycle Safety Foundation (MSF).

In the event of a crash, protective gear may prevent or reduce injuries. Protective gear also helps you stay comfortable and can help provide protection against the elements.

Recommended basic protective gear for riders and passenger includes sturdy over-the-ankle footwear with non-slip soles, long pants, a jacket, full-fingered gloves and, above all, an approved helmet with proper eye protection.

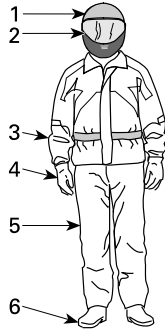

Riding Gear

1. *Approved helmet*
2. *Eye and face protection*
3. *Jacket with long sleeves*
4. *Gloves*
5. *Long pants*
6. *Over-the-ankle footwear*

Proper apparel can reduce the severity of injuries in case of a crash, either for the operator or the passenger.

Helmets

Helmets protect the head and brain from injury in case of an impact. A full-face helmet can also protect against elements such as debris, insects, stones, etc. Even the best helmet is no guarantee against injury, but statistics indicate that helmet use significantly reduces the risk of brain injury. So, be safe and always wear a helmet while riding.

Only wear a helmet that meets the appropriate standards required in your state, province or country (example of approved helmet marking: DOT or ECE 22.06). If not wearing a full-face helmet with integrated visor, always wear goggles with an open-face helmet to protect your eyes.

Note that ordinary glasses or sunglasses are not sufficient eye protection for a motorcyclist. They can shatter or fly off, and they allow wind and airborne objects to reach the eyes

Use tinted face shields, goggles or glasses in the daytime only; do not use them at night or in poor illumination. Do not use them if they impair your ability to discern color.

Other Riding Gear

Footwear

Always wear closed toe footwear. Sturdy over-the-ankle boots protect against a variety of riding hazards, such as stones that get thrown up from the roadway.

Avoid long shoelaces that can be tangled in the brake pedal or other parts. Rubber soles and low heels are a good idea to help keep feet on the footrests.

Gloves

Full-fingered gloves protect hands from the wind, sun, heat, cold and flying objects. Gloves that fit snugly will improve grip on the handlebar and help reduce hand fatigue. Sturdy, reinforced motorcycle gloves help protect hands in the event of a fall. Gloves made specifically for motorcyclists have seams on the outside to prevent irritation, and are curved to provide a natural grip when curled around the handgrips. If gloves are too bulky, it may be difficult to operate the controls. Gauntlets keep cold air from going up sleeves and protect the wrists.

Jackets, Pants and Riding Suits

Wear a jacket and long pants, or a full riding suit with padding, hard armor or airbag that may further reduce the risk of injury in a crash. Quality motorcycle-type protective gear will provide comfort, and it can help you avoid being distracted by adverse environmental elements. In case of a crash, good quality protective gear made of sturdy material like leather or abrasive-resistant fabric, may prevent or reduce injury.

Do not wear loose or long clothing or scarves that can become tangled in moving parts.

Be visible on the road. Choose riding gear with bright colors and reflective materials to increase your visibility, or simply add a reflective vest over your gear.

Hypothermia is a condition of low body temperature that can cause loss of concentration, slowed reactions and loss of smooth, precise muscle movement. In cool-weather riding, protect yourself against hypothermia by wearing insulated layers of clothing and windproof top layer gear. Dressing in layers allows you to remove clothing if you become too warm. Note that even at moderate temperatures, increased windchill while riding can cause you to feel cold.

Rain Gear

If you must ride in wet weather, a high-visibility motorcycle rain suit or a waterproof riding suit is recommended, along with waterproof gloves and footwear. On long rides, it is a good idea to carry rain gear. A dry rider will be much more comfortable and alert than a rider who is wet and cold.

Hearing Protection

Long-term exposure to wind noise when riding can cause permanent hearing loss. Properly worn hearing protective devices such as earplugs can help prevent hearing loss. Check local laws before using any hearing protective devices.

Vehicle Condition

Keep your vehicle in good operating condition. Have the vehicle undergo periodic checks and follow the maintenance schedule. See the Maintenance section for more details.

To detect any potential issue or malfunction with your motorcycle, perform a pre-ride inspection. Watch for any messages on the multifunction display when you start the vehicle. Correct any problems detected before you ride. See the [Pre-Ride Inspection, page 2-38](#) section for the complete checklist.

Have any outstanding safety recalls performed on your vehicle as soon as possible. Contact your authorized Can-Am dealer to schedule an appointment to have the necessary repairs completed free of charge.

Hazardous Materials

Lithium-ion high-voltage propulsion batteries are considered hazardous materials. Special care are required for BRP electric vehicles or high-voltage propulsion batteries disposal. Refer to local regulations regarding shipping or recycling requirement for hazardous materials. Contact an authorized BRP dealer for additional information.

GET FAMILIAR WITH THE MOTORCYCLE

WARNING

This vehicle may exceed the performance of other vehicles you may have ridden in the past. Take time to familiarize yourself with your new vehicle.

Inexperienced riders may overlook risks and be surprised by the vehicle's specific behavior and terrain conditions. Ride slowly. Excessive speed and reckless driving can kill.



Make sure you read and understand the content of this operator's guide to become completely familiar with the controls and operation of the motorcycle before embarking on your first trip or taking on a passenger (BRP passenger's seat kit required). If you have not had the opportunity to do so, practice driving solo in a suitable traffic-free area to become accustomed to the feel and response of each control.

It is very important to inform any operator, regardless of his experience, of the handling characteristics of this motorcycle. The motorcycle configuration, such as wheel stance, suspension type, weight, width and type vary from one model to another. The motorcycle handling is greatly influenced by these characteristics.

Driving Aid Technologies

This vehicle is equipped with an Antilock Braking System (ABS) and a Motorcycle Traction Control (MTC).

The ABS and MTC normally start in a not-ready state when the vehicle is turned on.

The ABS indicator  and the MTC indicator  come on when the vehicle is turned on and, will turn off when the speed threshold of 5 km/h (3.1 MPH) is reached.



If the indicators don't turn off after exceeding the speed threshold, it means the systems are not operational because of a malfunction.

The MTC indicator ! may also be visible in the multifunction display to indicate a malfunction.

If the ABS or MTC system malfunctions, see an authorized BRP dealer.

Anti-lock Braking System (ABS)

This motorcycle ABS system monitors and controls the front and rear brakes separately. The ABS response can be modified and, deactivated on the rear wheel, using different vehicle drive modes.



- When deactivated, the ABS indicator   will be visible in the multifunction display.

Refer to [Drive Modes, page 3-60](#) for more information.

Motorcycle Traction Control (MTC)

The MTC monitors and controls the propulsive wheel slip during acceleration and deceleration. It may happen that when you accelerate, the MTC prevents acceleration in order to maintain traction. Then, when the grip is restored, the motor torque will increase back to the value associated to the accelerator handle position.

The MTC can be modified and, deactivated using different vehicle drive modes.

- When active, the MTC indicator  will blink indicating that the rear wheel slip is limited to a safe value dependent on the selected Drive Mode.
- When deactivated, the MTC indicator  will be visible in the multifunction display.

Refer to [Drive Modes, page 3-60](#) for more information.

Limitations

The ABS and MTC cannot help you maintain control in all situations. The vehicle has been calibrated to perform best with the Original Equipment Manufacturer (OEM) tire assembled at the factory.

Replacing your tires with non-OEM ones can cause these systems to be less effective.

BRP recommends to only install OEM tires on your vehicle. Refer to the [Technical Specifications, page 6-2](#) for additional information or contact an authorized BRP dealer.

Proper tire inflation pressure and tread condition are important for maintaining traction, especially on loose or wet surfaces. Tire pressure that is too low may result in hydroplaning and excessive tire heat build up, while a tire pressure that is too high can reduce ABS or MTC effectiveness.

What's Different with a Can-Am Electric Motorcycle

This section will help you to understand some distinctive and operating features of this vehicle.

Noise Emission (Sound)

Under normal operating conditions, this electric motorcycle generates significantly less noise than a typical motorcycle with an internal combustion engine. After vehicle activation (start-up), the motorcycle will move upon accelerator twist grip input without emitting sound. You must be aware of bystanders accidentally touching the controls, when the motorcycle is stationary and propulsion system activated.

The operator must pay extra attention to the surroundings when driving the motorcycle. Bystanders may not hear the electric motorcycle approaching. Bystanders may not know that the electric motorcycle propulsion system is active.

WARNING

Avoid severe injury or death to you or bystanders. Be aware that this vehicle does not have engine noise when the propulsion system is enabled. The vehicle can be ready to drive without emitting sound. Learn how to recognize when the vehicle is READY to move from the multifunction display. Always check the state before reaching the accelerator grip. Turn OFF the stop switch to disable the propulsion system when not in use to prevent unintentional movement of the motorcycle from accidental twist of the accelerator grip.

 **WARNING**

Avoid severe injury or death to you or bystanders. This motorcycle emits no noise when stationary and low noise when operated. Bystanders may not be aware of your presence. Always make sure the surroundings is clear before moving.

No Parking Brake

This motorcycle does not have a parking brake nor a conventional motorcycle transmission that can use a gear to prevent the rear wheel from moving when parked. The rear wheel is mechanically connected to the electric motor at all times. When the motorcycle is powered off, the rear wheel can move in any direction.

When parking the motorcycle, make sure it is on a flat and level surface. If parking on an incline is the only option, block the rear wheel using the curb or a wheel chock. The side stand may not suffice to restrain the motorcycle from sliding down the incline. Before leaving the parked motorcycle on an incline, make sure it is immobilized adequately.

Regenerative Braking (Regen)

When the conditions allow it, the regenerative braking takes energy from the moving motorcycle through its rear wheel and stores it in the high-voltage battery for later use.

With two independent mode-controlled ways to request it, this feature can be set according to the user preferences as described in the [Regen modes, page 3-63](#) section.

The availability of regen will vary based on these settings and other parameters such as the state of charge and temperature of the high voltage battery.

The multifunction display will always display the currently available regen capability, refer to [Multifunction Display, page 3-34](#) for more information.

The regenerative braking differs from the vehicle brakes on many aspects such as:

- Only works on the rear wheel
- Does not work at very low speeds or at standstill
- Changing availability

It is therefore not a substitute for the vehicle brakes, which should be used to stop the vehicle.

 **WARNING**

Avoid being surprised and increasing the risk of crash. Regen capability will vary according to the state of the high-voltage propulsion system and could be disabled. Always be prepared to apply the brakes at all times by covering the front brake lever before requesting regen with the accelerator.

Carrying Loads

Carrying loads on the vehicle affects the vehicle handling, stability, autonomy and braking distance. Appropriate loading and weight distribution are therefore important. When carrying loads, such as cargo or a passenger, it is very important to follow the recommendations:

- Never load the vehicle above the specified weight capacity. Refer to the [Technical Specifications, page 6-2](#).
- Always adjust the suspensions according to the total load on the motorcycle. Refer to [Tune Your Ride, page 3-65](#).
- Never carry a load unless it is properly secured using a BRP LinQ certified accessory. Compatible accessories which are not BRP certified may not be considered as fit for this purpose.
- Always reduce your speed, turn gradually and allow longer braking distance when carrying loads.

**WARNING**

Failure to follow these recommendations when carrying loads could lead to a loss of control.

Accessories and Modifications

Any modifications or addition of accessories approved by BRP may affect the handling of your vehicle. It is important to take the time to get familiar with the vehicle once modifications are made to understand how to adapt your driving behavior accordingly.

Avoid installing equipment not specifically approved by BRP for the vehicle and avoid unauthorized modifications. These modifications and equipment have not been tested by BRP and may create hazards. For example, they could:

- Create a loss of control and increase risk of crash
- Cause overheating or short circuits increasing the risk of fire or burn injuries
- Affect the protection features provided by the vehicle
- Affect the behavior of the trailer when the vehicle is transported
- Cause a risk of losing objects on the road when transported.

Your vehicle may also become illegal to ride.

Ask your authorized BRP dealer for suitable available accessories for your vehicle.

For safety reasons, some BRP accessories must be installed by a BRP dealer but if you decide to install the accessory by yourself, when not required to be done by the dealer, it is important to follow all the instructions carefully and, if applicable, understand all the information on how to use the product or for servicing.

If the accessory has been installed on your vehicle by another person than you, BRP strongly recommends you to read the corresponding instruction sheet as there may be more for information on how to use it safely or for the servicing.

The instruction sheets can be found at this address:

- <https://instructions.brp.com>

Unauthorized Modifications

Any modifications or equipment installation not specifically approved by BRP performed to the low voltage electrical system of this vehicle may affect the high voltage battery management system and impact the vehicle safety, life expectancy and warranty.



Do not install equipment not specifically approved by BRP or perform unauthorized modifications of this vehicle electrical systems

RIDE SAFELY

Plan your Trip

Always check weather conditions before riding the vehicle. Take appropriate gear for any weather you might encounter.

Plan a route and ride in conditions that are appropriate for your skill level. Ride prepared for the conditions you may encounter. Carry water and snacks, tools, trail maps, a cell phone and a first-aid kit.

The vehicle has a 8.9 kWh battery capacity. When the battery state of charge indicator light flashes, recharge as soon as possible. Plan your recharging stops, particularly in unpopulated areas.

Vehicle Range

The range is defined as the distance the vehicle travels with a single full charge of the battery. A variety of factors can influence the vehicle's range and the time until charging is needed, including:

- **Weather:** In addition to temperature, slippery conditions and strong headwinds can adversely affect driving range and performance.
- **Terrain:** Rough terrain or frequent and difficult hill climbs require more power from the vehicle, thus affecting range.
- **Payload:** A passenger and cargo increase demand on the vehicle.
- **Style of Driving:** An aggressive or high-speed driving style utilizes more power than a conservative driving style. Highway vehicle usage requires significantly more power.

- **Starting and Stopping:** It takes more energy to accelerate to a cruising speed than it does to maintain the same speed. Deceleration with regen will help increase vehicle range.
- **Accessories:** Additional accessories can add weight and energy draw.

The range is calculated using two types of industry standard test procedures:

- **City:** This range test is specified to determine riding during “stop-and-go” operation typically found in urban areas.
- **Combined:** This range test is based on a calculation that assumes a duty cycle comprised of 50% city/ 50% highway.

City	145 km (90 miles)
Combined	115 km (71.5 miles)

Data from previous trips, such as performance and driving style, is used for calculating vehicle range.

Riding Alone

Venturing out alone with your electric motorcycle could also be hazardous, especially when going off-road in trails. You could run out of power, have an accident or damage your motorcycle. Remember, your motorcycle is capable of traveling further distance than you may be able to walk in a day. Ride with a friend and always tell someone where you are going and the approximate time you plan to return.

Riding in Group

Before starting out, have a rider's meeting to discuss the route, rest and charge stops, agree on hand signals and determine the pace based on each rider's skill levels. Designate a lead rider and a sweep (tail) rider. Both lead and sweep riders should be experienced riders and know about group riding procedures. When riding with others, keep the group to a manageable size or break it into smaller groups. Maintain a proper following distance of at least two (2) seconds between motorcycles to provide riders enough time and space to react in case of hazards. On the road, ride in staggered formation. Each rider should periodically check the following rider and slow down in case a rider is falling behind to allow to catch up. No rider should break the law or ride beyond their ability to catch up.

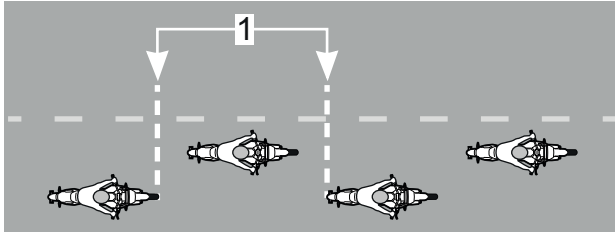

On Road Staggered Group Riding Position

1. Distance of at least 2 seconds

Riding with a Passenger

This vehicle is designed to be used by one (1) operator. When equipped with a BRP passenger's seat kit, this vehicle can carry only one (1) passenger behind the operator. Never try to carry more than one passenger.

! WARNING

Never carry a passenger if a BRP approved passenger's seat kit is not installed on vehicle.

Do not carry a passenger until you have experience riding alone in a variety of conditions and can proficiently handle the vehicle.

The passenger must always be able to firmly lay his feet on the footpegs and keep his hands on the handgrips or hold on to the operator to reduce the risk of ejection.

The operator has a responsibility to ensure the safety of the passenger and should inform the passenger about motorcycling basics. Remind your passenger to lean into the turn with you, without causing the vehicle to topple.

Before riding the vehicle, adjust suspension according to weight. Refer to [Tune Your Ride, page 3-65](#) for more details.

Be extremely careful, go more slowly and check the passenger frequently. Keep a watchful eye on your passenger while riding. Ask your passenger to inform you to slow down or stop immediately if feeling uncomfortable or insecure during the ride.

Braking ability and steering control are reduced when riding with a passenger. Decrease speed and allow extra space to maneuver.

Riding with a Trailer

This vehicle is not designed for towing loads.

Do not tow a trailer or any other type of carrier with this vehicle.

Do not modify the vehicle to tow.

Avoiding Collisions

Always keep a safe distance from other vehicles and bystanders. Tailgating another vehicle should be avoided as it does not allow sufficient reaction time. Maintain a safe stopping distance between you and the vehicle in front of you by leaving at least a two-second following distance. When conditions make braking distance longer, or visibility is limited, use a longer following distance for a greater margin of safety. Play it safe

Always be on the look-out for the unexpected. Scan for people, objects, upcoming vehicles and other potential hazards. Plan ahead and leave space and time to anticipate and avoid trouble. You need to stay alert at all times. Always be aware of your surroundings. Watch behind, by frequently checking your mirrors and your blind spots, and to the sides. When braking, be aware of vehicles behind you that may not be able to stop as quickly as you.

Be visible to others. Make sure your lights are on and working properly. Use your turn signals to inform of your intentions and make sure to cancel them after you completed your maneuver; leaving them on may confuse others. Avoid riding in blind spots.

On the trail, always stay on the appropriate side- as per country regulation- to avoid collision, especially when the field of vision is reduced (e.g., before a hilltop or curve). Never assume there are no other user on the trail. Use extra caution whenever off-trail.

Riding Behavior

Ride within your limits and level of riding ability and respect the motorcycle's intended use. Avoid aggressive operation, zig zagging between lanes or through traffic.

Jumping can be a hazardous situation. It requires practice and should be done in a known and controlled environment. Never attempt jumping on a trail. A loss of control could lead to an impact with rocks, trees or another user.

Speeding

Excessive speed and reckless driving can be fatal. Follow speed limits in effect for the road or trail you are using. Know your local rules. Always adjust your speed according to the road conditions, weather conditions and your own ability. In many cases when speeding, you cannot react or respond quickly enough to the unexpected.

Road Conditions and Hazards

Surfaces with Poor Traction

The grip of tires on the road surface limits the maximum braking and traction of the motorcycle. Even with ABS and MTC, your stopping distance will be longer:

- on surfaces with poor traction (e.g. leaves, oil, sand, mud, gravel, snow, wet pavement, etc)
- if you do not maintain recommended tire pressure, or
- if tire tread condition is degraded.

On surfaces with poor traction, like mud, sand, gravel, wet pavement or leaves, use extra caution and reduce your speed.

If your tires lose traction with the road surface, even with ABS or MTC, you may lose control of the vehicle.

If the road surface is covered or partially covered with ice, snow or slush, there is not enough traction available to maintain control of the vehicle. Do not operate on snow, ice or slush.



NOTE

The grip of the vehicle tires starts to decrease below 10 °C (50 °F).

A proper selection of the vehicle drive mode may help you adjust the vehicle's reaction for the surface condition. Refer to [Drive Modes, page 3-60](#) for additional information.

Wet Pavement

Water



WARNING

Your vehicle is designed to withstand wet conditions, including rainfall or puddles. However, long-term submersion (floods, salt-water) of the vehicle can cause damage or render the vehicle temporarily inoperable. If the vehicle is submerged, stop using the vehicle. The vehicle should be inspected by an authorized BRP dealer prior to next ride. Contact local emergency service for immediate assistance if any signs of thermal event occur.

There is normally enough traction to maintain control on pavement that is moist or wet, as long as there is not a layer of water on top of the pavement (like a puddle or flowing water on the road). This vehicle can hydroplane if you ride too fast into a layer of water that has accumulated on the road. You are more likely to hydroplane in deeper water. Watch for splashing or spraying when other vehicles go through water as an indicator of depth.

When hydroplaning occurs, one or more wheels rise up on a layer of water, losing contact with the road. Hydroplaning wheels do not have the traction necessary to control the vehicle. You can lose control and spin out, and the ABS or MTC cannot keep you in control.

Avoid large water puddles or water streams, and slow down or pull off the road during heavy rains. If you must pass through water, slow down as much as possible before you reach it.

The middle of a lane can be particularly slick in the first few minutes of rain, as oil and dirt combine with the water. After more rain, water can accumulate in ruts in worn pavement. Avoid both of these low traction areas.

After passing through water, test your brakes. Apply them several times if necessary to let friction dry the brake pads.

Properly maintained tires reduce the risk of hydroplaning. Always maintain recommended tire pressure.

Refer to [Tire Pressure, page 4-16](#) and [Technical Specifications, page 6-2](#).

Immediately replace any tire that shows the maximum tread wear indicator to minimize risk of hydroplaning.

Inclines

This electric motorcycle's e-motor is connected to the rear wheel, but the e-motor friction will not hold the vehicle in place.

When stopped, the vehicle can roll. Hold the brake lever and/or brake pedal when stopped on an incline. To start from a standstill while on an incline, hold the brake pedal and/or brake pedal as you accelerate. Release the brake(s) as you feel the accelerator handle response.

Obstacles, Holes and Bumps

Whenever possible, avoid riding over obstacles, holes and bumps. If you must ride over them, slow down as much as possible before you get there, then release the brake as you go over.

For railways crossing, always approach as perpendicular as possible to the railroads to reduce the risk of sliding.

For wide obstacles or bumps, approach straight on if possible. When going over an obstacle, bump or hole, riders should stand up slightly on the footrests and use legs to absorb the shock.

For narrower obstacles, bumps or holes, if you ride over them, maintain a firm grip on the handlebar and take care not to accidentally activate the accelerator handle. Be prepared to correct your trajectory if necessary.

If you strike a large enough obstacle, bump or hole, the impact can make the vehicle jump and strike you, eject riders, make you lose control, spin or fall.

If you can't come to a complete stop in time to avoid an obstacle, you can swerve to avoid it.

CAUTION

It is advisable to avoid steering and braking at the same time. It is preferable to brake when the vehicle has returned to the vertical position. The vehicle can easily slip or fall if the brake is applied during a steering maneuver.

If you encounter a large animal in the road, like a deer, it is best to stop before reaching it and wait until the animal leaves, or go past slowly.

Know the Terrain - Off-Road Use

This vehicle has been designed and manufactured for off-road use. Even if the vehicle can handle the rough, low-traction, uneven surfaces that you may encounter in off-road riding, you could get stuck, lose control or fall down.

Experienced users can select the **OFF-ROAD** or **OFF-ROAD +** modes when driving under these conditions. Refer to [Drive Modes, page 3-60](#) for more details.

Downhill

Downhill driving requires that you have full control of your vehicle at all times. Keep your bodyweight rearwards and both hands on the handlebar. Stay seated. Try to avoid steep inclines. Maintain steady speed and/or accelerate slightly to regain control. If a higher than safe speed is reached, slow down by braking but apply the brake with frequent light pressure. Never lock the wheels.

Uphill

There are two types of hills you can encounter — the open hill on which there are few trees, cliffs or other obstacles, and a hill that can only be climbed directly. On an open hill, the approach is to climb it by side hilling or slaloming. Approach at an angle. Adopt a standing position. Keep your weight on the uphill side at all times. Maintain a steady, safe speed. Continue as far as you can in this direction, then switch to an opposite hill angle and riding position.

A direct climb could present problems. Choose the standing position and accelerate before you start the climb.

In either case, the vehicle speed should be as fast as the incline demands. Always slow down as you reach the crest. If you cannot proceed further, change route direction. Position and stabilize the motorcycle perpendicular to the hill using the brakes, position yourself to avoid tipping over, then descend the hill.

Side Hill

When crossing a side hill or traversing up or downhill, certain procedures must be followed. All riders should lean towards the slope as required for stability. The preferred operating position is the standing position, with both feet on footrest. Be prepared to shift your weight quickly as needed. Side hills and steep slopes are not recommended for a beginner or a novice rider.

Night Rides

The amount of natural and artificial light at a given time can affect your ability to see or to be seen. Be extra cautious. Drive at speeds that will allow you to stop in time when you see an unknown or dangerous object ahead. Stay on established trails and never operate in unfamiliar territory. Be sure both headlights and taillight are working and clean.

Unfamiliar Territory

Whenever you enter an area that is new to you, drive with extreme caution. Go slow enough to recognize potential hazards such as fences or fence posts, brooks crossing your path, rocks, sudden dips, guy wires and countless other obstacles which could result in a termination of your motorcycle ride.

Driving off established trails and in the woods requires reduced speed and increased vigilance. Driving too fast in an area can make even minor obstacles very hazardous. Even hitting a small rock or stump could throw your motorcycle out of control and cause injury to its riders. Even when following existing tracks, be cautious. Travel at a speed so you can see what is around the next bend or over the top of the hill.

Hidden Wires

Always be on the lookout for hidden wires, especially in areas that may have been farmed at one time or another. Too many accidents have been caused by running into wires in the fields, guy wires next to poles and roads, and into chains and wires used as road closures. Slow speeds are a must.

Riding Uneven Surfaces

Unplanned jumps of tree roots, fallen trees, ridges, culverts, indistinguishable objects or sudden drops in the trail can be dangerous. A good way to help see these terrain variations is to wear the proper color lenses or face shields and by operating at a lower speed.

Railroad Crossing

Never ride on railroad tracks. It is dangerous and may violate applicable laws. Railroad tracks and railroad rights-of-way are private properties. A motorcycle is no match for a train. Refrain from crossing unmarked railroad tracks. If necessary to cross an unmarked railroad track, stop, listen and look both ways before crossing the tracks.

Riding Uneven Surfaces

Unplanned jumps of tree roots, fallen trees, ridges, culverts, indistinguishable objects or sudden drops in the trail can be dangerous. A good way to help see these terrain variations is to wear the proper color lenses or face shields and by operating at a lower speed.

In Case of an Accident

Depending on the severity of the situation, precautions must be taken if the high-voltage components have been damaged creating a risk of electric shock and / or fire.

BRP electric vehicles have a monitoring system which will indicate if the high-voltage system is defective, this will be visible in the multifunction display with telltale icons and warning messages.

- Stay alert to signs of a lithium battery fire, such as smoke, popping / hissing sound, or burn smell emitting from the high-voltage battery.
- Avoid unnecessary manipulation of the vehicle.

Turn the key off and let the vehicle power down (multifunction display turns off).

If necessary to stand the motorcycle, lift by the handlebar grips only.

Visually inspect visibly accessible high-voltage components, such as the high-voltage battery covers for dents or cracks, high-voltage cables for tears or cuts, etc.



Avoid contact with high-voltage that will cause severe injury or death.

If any damage is found, the high-voltage components may be compromised. Do not attempt to manipulate the vehicle. Contact local emergency services for immediate assistance. Refer to [Emergency Response, page 2-19](#).

If no external damage to the high-voltage components is found, turn the key on.

If any fault codes or messages are displayed in the multifunction display, turn the key back off and see an authorized BRP dealer. Refer to [Emergency Response, page 2-19](#).

If no codes or messages are displayed, then proceed with the following.

Refer to [Maintenance procedures](#) and inspect the following:

- Perform a full Pre-ride inspection. Refer to [Pre-Ride Checklist, page 2-38](#)
- Check coolant level and refill if necessary refer to [Coolant level verification, page 4-12](#) and [Coolant refill, page 4-13](#). Avoid riding your vehicle if a leak is present, the high voltage system requires a functional cooling system.

The vehicle should be inspected by an authorized BRP dealer as soon as possible, and repaired by an authorized BRP dealer if required. In any circumstances, the vehicle should be parked/stored outside until an inspection has been completed.

 **WARNING**

Always assume a damaged vehicle's high voltage system is charged and energized. The high-voltage components on the vehicle should only be serviced by an authorized service technician. Do not tamper with the high-voltage components in any way.

 **WARNING**

Contact local emergency services for immediate assistance if any signs of smoke or fire appear..

Tipped Over Vehicle

The motorcycle is equipped with a tip over position sensor (TOPS). This sensor allows to detect if the vehicle is laying on its side and activate the tip over function.

When the tip over function is active:

1. The propulsion system is disabled and cannot be enabled;
2. The hazard lights function is on (turn signals are flashing);
3. The "Vehicle Tipped" message is visible on the multifunction display;
4. The Propulsion system malfunction tell-tale blinks.

Visually inspect visibly accessible high-voltage components, such as the high-voltage battery covers for dents or cracks, high-voltage cables for tears or cuts, etc.

 **DANGER**

Avoid contact with high-voltage that will cause severe injury or death. If any damage is found, the high-voltage components may be compromised. Do not attempt to manipulate the vehicle. Contact local emergency service for immediate assistance. Refer to [Emergency Response, page 2-19](#).

If no damages are apparent, put the vehicle back on its wheels, deploy the side stand and disable the tip over function.

To disable the tip over function, the motorcycle must be set upright and the key switch cycled to off then on.

If any fault codes or messages are displayed in the multifunction display, turn the key back off and see an authorized BRP dealer. Refer to [Emergency Response, page 2-19](#).

If no codes or messages are displayed, then proceed with the following.

Refer to [Maintenance Procedures, page 4-8](#) and inspect the following.

- Perform a full pre-ride inspection. Refer to [Pre-Ride Checklist, page 2-38](#).
- Check coolant level and refill if necessary. Avoid riding your vehicle if a leak is present, the high voltage system requires a functional cooling system.

Whenever the vehicle is tipped over, it should be inspected by an authorized BRP dealer.

Tire Failure

If a tire failure or a blowout suddenly occurs, firmly grip the handlebar, gradually slow down and carefully steer to a safe place to stop. Avoid hard braking or sharp steering.

If control is lost and a tip over occurs, refer to the [Emergency Response, page 2-19](#) or [Tipped Over Vehicle, page 2-18](#). If it is safe to manipulate the vehicle, it should be transported to an authorized BRP dealer for inspection and tire replacement. Refer to [Transporting the Vehicle, page 2-21](#).

Emergency Response

BRP electric vehicles are equipped with safety features for your protection. In the event of an incident, accident or submersion in water additional precautions must be taken to protect yourself from the high-voltage hazards created by the external and/or internal damages to the high-voltage components.

If such an event occurs, stop using the vehicle. The vehicle should be inspected by a BRP dealer prior to next ride. Contact local emergency service for immediate assistance.

DANGER

The lithium-ion high-voltage propulsion battery or high-voltage components can cause electrical shock and/or fire when damaged.

Do not disconnect or touch any exposed connections and/or damaged components with bare fingers, non-insulated tools or other metallic objects. Contact with high-voltage current will cause severe injury or death.

A damaged lithium-ion high-voltage battery can leak electrolyte and/or generate flammable gas. Contact with electrolyte will cause severe injury, rinse the affected area with water and seek for immediate medical attention.

The vehicle high-voltage system must be disabled using the First Responder Cut Loop (FRCL) cut locations. They can be exposed by removing the driver's seat or the lower body panel on either side of the motorcycle. Refer to [Safety Labels, page 2-28](#).

The FRCL usage is reserved to the emergency personnel or first responders only. The electric motorcycle should only be lifted or manipulated by personnel properly trained, equipped and advised that the vehicle presents high-voltage hazards.

Additional information can be found in the vehicle's *Emergency Response Guide* available at this address:

- operatorsguides.brp.com

TRANSPORTING THE VEHICLE

 DANGER

Avoid contact with high-voltage that will cause severe injury or death. If the vehicle has been involved in an accident, the high-voltage components may be compromised.

Do not attempt to move the vehicle on a trailer or tow truck yet. Do not tow the vehicle at any speed to cause the rear wheel to move. Contact local emergency service for immediate assistance. Refer to [Emergency Response, page 2-19](#).

If your vehicle needs to be transported, it should be carried on a flatbed trailer of the proper size and capacity or a flatbed towing truck to prevent the rear wheel from moving.

 WARNING

Make sure all seats, accessories and cargo are properly secured, or remove it to prevent from falling on the road and creating a hazard for following vehicles.

 WARNING

Do not transport the vehicle facing backwards. If the vehicle is transported facing backwards, the wind may cause damage to the windshield or even loss of the windshield.

The vehicle's electric motor is mechanically connected to the rear wheel and can generate electricity when rotated.

NOTICE

This vehicle is equipped with an electric motor capable of generating a voltage when rotated. If the key is OFF or the high-voltage battery pack is depleted, further damage could occur to the motor or the inverter if the rear wheel is rotated.

With the vehicle powered OFF, avoid pulling, pushing or towing the vehicle to cause the rear wheel to rotate. If necessary, the vehicle may be temporarily moved at a speed no greater than 10 km/h (6 mph).

The vehicle must be secured in an upright position whenever it is being lifted or manipulated. Never use metal or conductive components to lift, manipulate, or secure the vehicle.

When contacting a towing or transporting service, be sure to ask if they have a flatbed truck, loading ramp or power ramp to safely lift the vehicle, tie-down straps and wheel chock for motorcycles. Ensure the vehicle is properly transported as specified in this section.

NOTICE

Avoid using chains to tie the vehicle — they may damage the surface finish or plastic components.

To load the vehicle for transport, proceed as follows:

1. Press the stop switch in the stop position.
2. Remove the key from the key switch.

- Put a strap around the front fork outer tubes, between the lower and upper triple clamps.

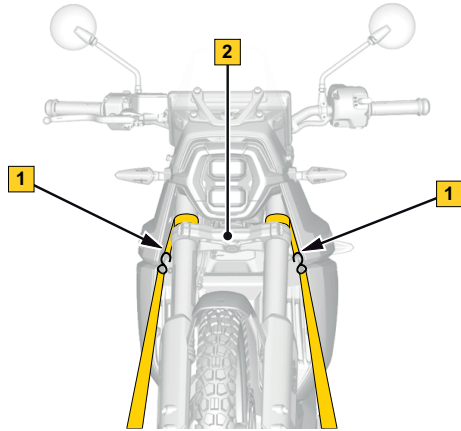

typical

- Strap
- Lower triple clamp

- Attach the straps to the winch cable. If possible, use chains or additional straps to attach the straps to the winch cable as indicated below to avoid damaging the vehicle.

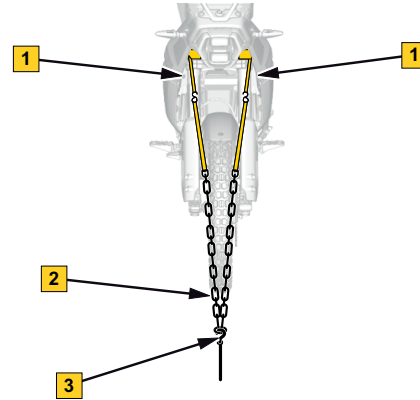

typical

- Strap around front suspension lower triple clamp
- Chains or straps
- Winch cable

- Pull the vehicle on the flatbed trailer with the winch. The front wheel should be secured in a motorcycle wheel chock.

NOTE:

If you need to push the vehicle, do it from the left-hand side to be able to access the side stand if necessary and have your right hand on the brake lever to stop the vehicle when needed.

- Attach front tie-down straps to the flatbed with ratchets straps. Ensure that the front fork is slightly compressed when tightening the straps. This will prevent the straps from loosening or unhooking during transport.

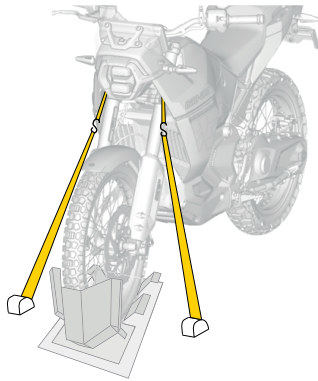

- Pass a tie-down strap inside the rear wheel rim only. Do not pass the tie-down strap above the swing arm or use wheel spokes to secure the vehicle.

NOTICE

Passing the tie-down strap above the swing arm or using wheel spokes may damage the vehicle.

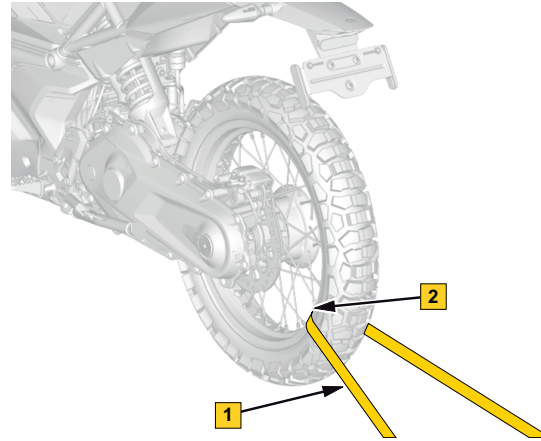

Rear wheel attachment - typical

- Tie-down strap
- Inside rear wheel rim ONLY

- Firmly attach the rear wheel tie-down strap to the rear of the flatbed with a ratchet strap.

-
9. Ensure that both straps around the fork outer tubes are firmly attached to the flatbed.

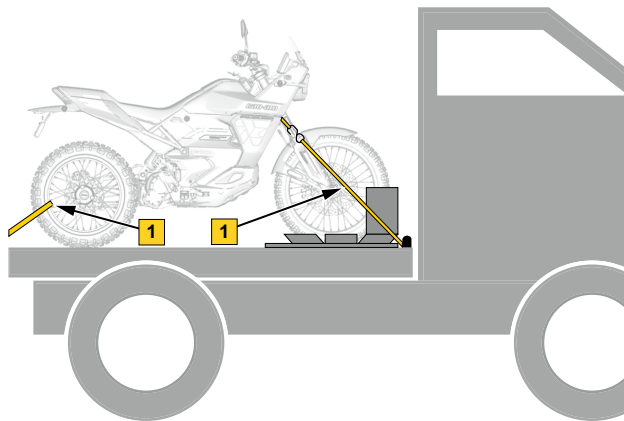

typical - vehicle facing towards front of towing

1. Front and rear wheel firmly attached to flatbed

SAFETY INFORMATION ON THE VEHICLE

This vehicle comes with hang tags and labels containing important safety information.

Any person who rides this vehicle should read and understand this information on the vehicle before riding.

In the event of any discrepancy between this guide and the vehicle, the safety labels on the vehicle have precedence over the labels in this guide.

Important Pre-Ride Safety Message

An important safety message is displayed in the multifunction display, each time the vehicle is ready to start.

Read and understand it carefully.

To see the entire message, scroll it on the screen using your finger.

WARNING

This Can-Am Electric motorcycle is different from other vehicles. It requires special skills and knowledge. Read the operator's guide. Complete a training course, practice, become proficient with the controls, and get a proper license.

Wear a helmet, eye protection and riding gear.

Know the limits for different road conditions. Do not ride on ice or snow. Avoid puddles and running water.

This type of vehicle can hydroplane on water and slip on gravel, dirt and sand covered roads. If you must go through these road conditions, slow down.

Always keep in mind: Electric vehicles generate low noise levels. Always make sure the surrounding is clear before moving. Bystanders may not be aware of your presence.

Regenerative braking will vary depending on power unit temperature and charge level. Be prepared to apply the brakes at all times. Twist the accelerator handle backward (away from you) to enable the vehicle to operate.

Safety Hang Tag

▲ WARNING

This Can-Am Electric motorcycle is different from other vehicles. It requires special skills and knowledge.

Read the operator's guide. **Complete** a training course, **practice**, become proficient with the controls, and get a proper license.

Wear a helmet, eye protection and riding gear.

Know the limits for different road conditions.

Do not ride on ice or snow. Avoid puddles and running water. This type of vehicle can hydroplane on water and slip on gravel, dirt and sand covered roads. If you must go through these road conditions, slow down.

Always keep in mind:

Electric vehicles generate low noise levels. Always make sure the surrounding is clear before moving.

Bystanders may not be aware of your presence.

Regenerative braking will vary depending on power unit temperature and charge level. Be prepared to apply the brakes at all times.

This hangtag may only be removed by the customer.

10071

▲ AVERTISSEMENT

Cette motocyclette électrique Can-Am est différente des autres véhicules. Elle exige des compétences et des connaissances particulières.

Lisez le guide du conducteur. **Suivez** une formation, **exercez vous**, apprenez à maîtriser les commandes et obtenez le permis approprié.

Portez un casque, une protection pour les yeux et des vêtements appropriés.

Apprenez à connaître les limites dans différentes conditions routières. Ne conduisez pas sur la glace ou la neige. Évitez les flaques et les ruissellements d'eau. Ce type de véhicule peut faire de l'aquaplanage sur les chaussées détrempées et déraiper sur les routes couvertes de gravier, de terre ou de sable. Si vous devez conduire dans ces conditions, ralentissez.

Gardez toujours à l'esprit:

Les véhicules électriques génèrent un faible niveau de bruit. Assurez-vous de vérifier l'environnement autour du véhicule avant de vous déplacer. Les passants pourraient ne pas être avertis de votre présence.

Le freinage régénératif variera en fonction de la température et du niveau de charge du groupe motopropulseur. Soyez prêt à utiliser les freins en tout temps.

Cette étiquette ne peut être retirée que par le client.

10071

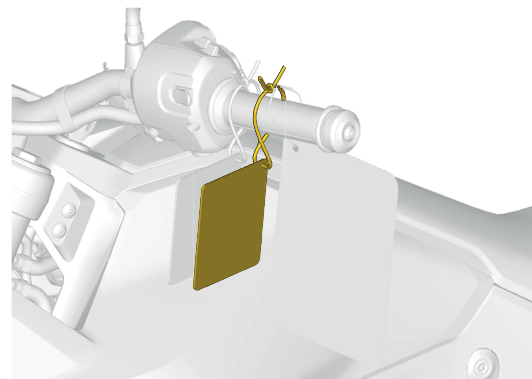

Compliance Hang Tag

California Proposition 65 Warning

⚠️WARNING: Operating, servicing and maintaining a passenger vehicle or off-highway motor vehicle can expose you to chemicals including engine exhaust, carbon monoxide, phthalates, and lead, which are known to the State of California to cause cancer and birth defects or other reproductive harm. To minimize exposure, avoid breathing exhaust, do not idle the engine except as necessary, service your vehicle in a well-ventilated area and wear gloves or wash your hands frequently when servicing your vehicle. For more information, go to www.P65Warnings.ca.gov/passenger-vehicle.

⚠️WARNING: Battery posts, terminals and related accessories contain lead and lead compounds, which are known to the State of California to cause cancer and birth defects or other reproductive harm. To minimize exposure, wear gloves or wash your hands frequently when servicing your vehicle. For more information, go to www.P65Warnings.ca.gov

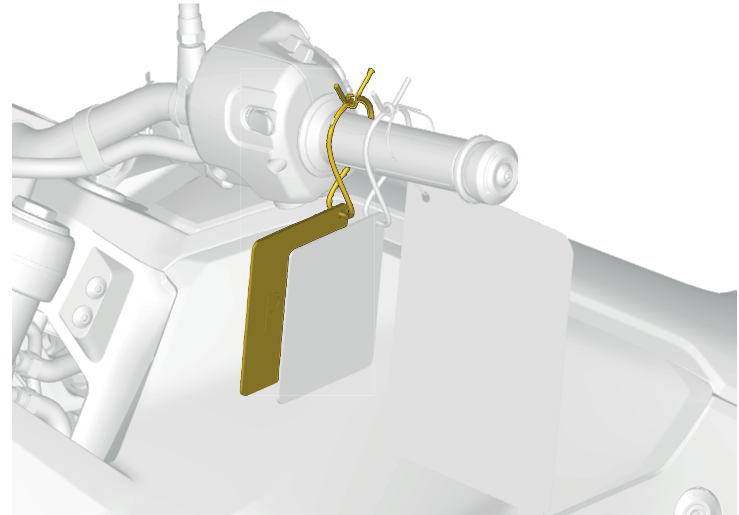

Safety Labels

The following labels are on your vehicle and they should be considered permanent parts of the vehicle. If missing or damaged, the decals can be replaced free of charge. Visit an authorized BRP dealer.



PASSENGER WARNING LABEL

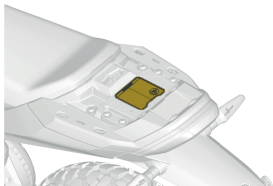

Accessory Support

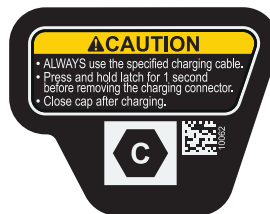

Charging Instruction Label — Canada and USA models

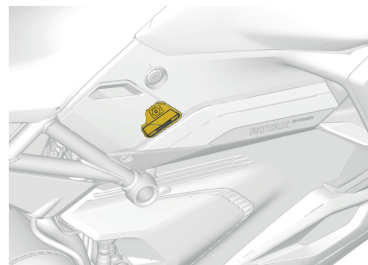

Charging Port Cover



Electric Shock Label

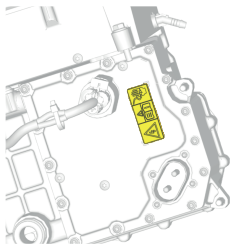

Inverter

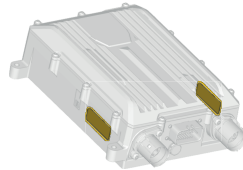

On-Board Charger



High Voltage Label

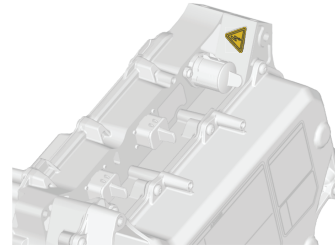

High Voltage Battery

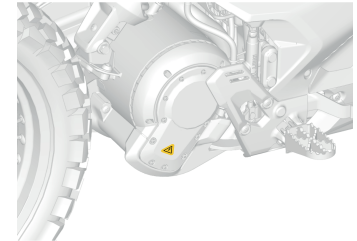

E-Motor

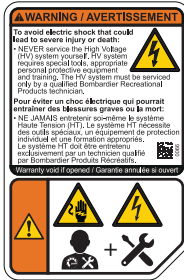

High Voltage Warning Label

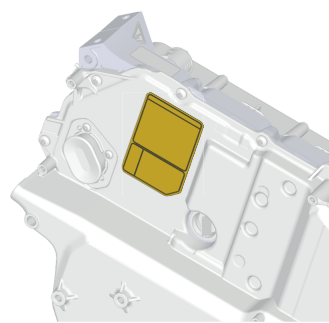

High Voltage Battery

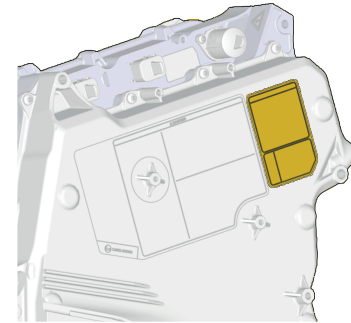

High Voltage Battery

Label Text

WARNING

To avoid electric shock that could lead to severe injury or death:

NEVER service the High Voltage (HV) system yourself. HV system requires special tools, appropriate personal protective equipment and training. The HV system must be serviced only by a qualified Bombardier Recreational Products technician.

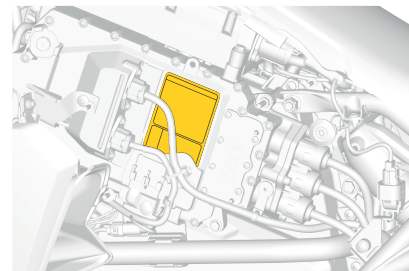

Inverter

First Responder Cut Loop (FRCL)

The label identifies the cable to cut to disable the high-voltage system during an emergency response. The FRCL usage is reserved to the emergency personnel or first responders only.



FRCL Label

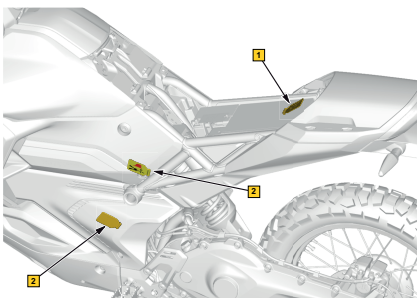

1. Driver Seat Compartment
2. High Voltage Battery sides (LH, RH)



Coolant Reservoir Cap

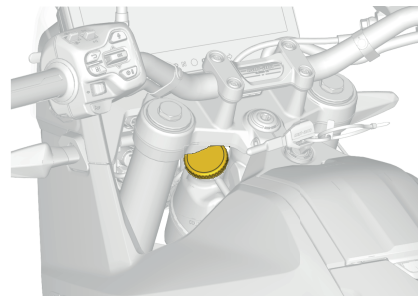

Coolant Reservoir

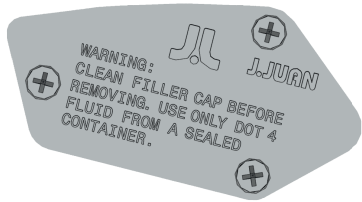

Front Brake Fluid

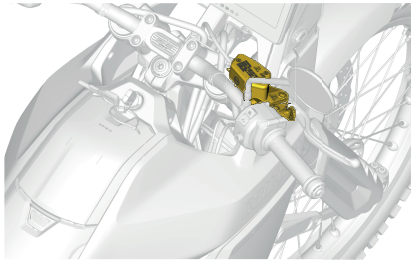

Front Brake Fluid Reservoirs



Rear Brake Fluid

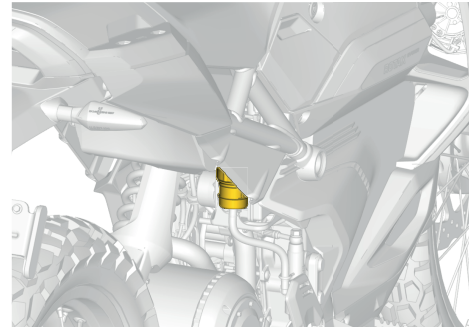

Rear Brake Fluid Reservoirs

Vehicle Information Hang Tag



STAY CONNECTED WITH YOUR CAN-AM MOTORCYCLE

Access last-known vehicle information right from your phone

BATTERY LEVEL

ESTIMATED RANGE LEFT

ESTIMATED TIME TO FULL CHARGE

VEHICLE LOCATION

FIRST RIDE





- 1 Download the BRP GO! app
- 2 Create your BRP GO! account
- 3 Allow Precise Location tracking in the app
- 4 Add your vehicle to your account
Go to My Profile > Add Vehicle
- 5 Pair your phone to your vehicle via Bluetooth



EACH RIDE

- 1 Open BRP GO! on your phone
Make sure you are logged in and your phone is paired to your vehicle
- 2 Go ride
- 3 Consult your vehicle's last-known information
Go to My Profile > My Vehicles

SCAN TO DOWNLOAD BRP GO!



MAKE THE MOST OUT OF YOUR 10.25" DISPLAY

APPLE CARPLAY

Use your favorite apps on your vehicle display

- 1 Pair your headset to your vehicle via Bluetooth
- 2 Connect your iPhone to your vehicle via USB cable
- 3 Open the Apple CarPlay applet
- 4 Enjoy your favorite apps (Google Maps, Spotify, and more)

HANDLEBAR CONTROL MODULE

Easily control the applets and ride settings on the go

APPLET SWITCHER
Cycle through your preferred applets



RIDE SETTINGS
Adjust the vehicle dynamics to fit your ride style



VOICE ASSISTANT
Get hands-free help with Siri or Google Assistant



SCAN TO LEARN MORE ABOUT THE 10.25" DISPLAY



704910482

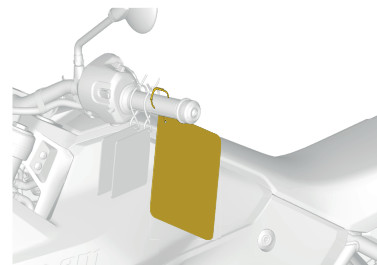

Multifunction Display Hang Tag

Vehicle Information Labels

MFD BY / FABRIQUÉ PAR: BOMBARDIER RECREATIONAL PRODUCTS Inc				COLD INFL	
GVWR / PNBV: <input type="text"/> kg (<input type="text"/> lb)				PRESSURE/	
TIRE/ PNEU	GAWR/PNBE	TIRE SIZE/ DIM. PNEU	RIM SIZE/ DIM. JANTE	PRESSION DE	
FR/AV	kg (lb)			GONFL À FROID	
RR/AR	kg (lb)			kPa (psi)	
				kPa (psi)	

Tires Information Label



Front forks

BATTERY SERIAL NUMBER

S/N:

High Voltage Battery Serial Number - Quick Reference Label

2

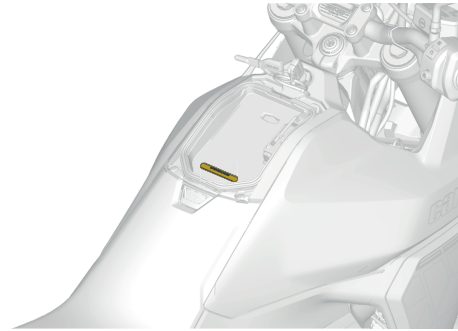

Glove Compartment

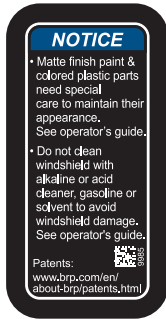

Vehicle Care Notice Label

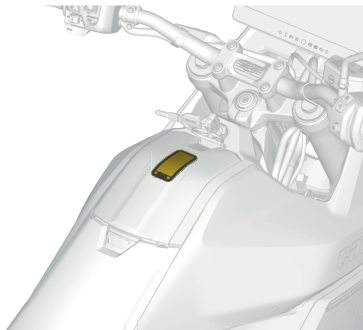

Glove Compartment

REPORTING SAFETY DEFECTS

Your safety is very important to Bombardier Recreational Products Inc. (BRP). If you have any concerns you should immediately contact BRP customer service.

If you believe that your vehicle has a defect which could cause a crash or could cause injury or death, you should immediately inform the following authorities in addition to notifying Bombardier Recreational Products Inc.:

- In the USA, the National Highway Traffic Safety Administration (NHTSA)
- In Canada, Transport Canada
- In other countries, the competent authorities.

If any of these authorities receives similar complaints, it may open an investigation, and if it finds that a safety defect exists in a group of vehicles, it may order a recall and remedy campaign.

However, these authorities cannot become involved in any individual problems between you, your dealer or Bombardier Recreational Products Inc.

To contact NHTSA:



888-327-4236



1 800-424-9153



National Highway Traffic Safety Administration
1200 New Jersey Avenue, SE
Washington, DC 20590



www.safercar.gov

To contact Transport Canada:



819-994-3328 (Gatineau-Ottawa area or internationally)
Toll free : 1 800-333-0510 (in Canada)



Transport Canada - ASFAD
330 Sparks Street
Ottawa, ON
K1A 0N5



<https://www.tc.gc.ca/recalls>

PRE-RIDE INSPECTION

Pre-Ride Checklist

We encourage you to have periodic checks and follow the maintenance schedule of your vehicle. Though not required, it is recommended that an authorized Can-Am On-Road dealer performs the preseason preparation of your vehicle. Each visit is a great opportunity for your dealer to verify if your vehicle is included in any warranty safety recall or has applicable software updates. We also urge you to visit your authorized Can-Am On-Road dealer in a timely manner if you become aware of any safety recall campaigns.

DANGER

Risk of SERIOUS INJURY or DEATH from ELECTRIC SHOCK, ARC FLASH or FIRE.

The vehicle's high-voltage propulsion system is a self contained system.

- Do not tamper with the high-voltage components in any way.
- The user safety is ensured as long as the high-voltage components are not manipulated and/or modified while the vehicle is activated.
- BRP strongly recommends tasks involving the high-voltage propulsion system to be performed by an authorized BRP dealer.

WARNING

Avoid electric shock that could lead to severe injury or death when performing inspections, maintenance works, or adjustment procedures.

- Procedures not described in the following sections require special tools and thorough knowledge of the technology involved.
- Do not perform tasks that deviates from those contained in this operator's guide.
- Always perform inspections, maintenance and/or adjustment tasks described in the following sections with the vehicle charging cable disconnected, the stop switch in the OFF position and the vehicle key removed, unless otherwise stated.
- Usage of personal protective equipment (PPE), such as safety glasses and shoes, is recommended.

**WARNING**

Perform a pre-ride inspection before each ride to detect potential problems during operation. The pre-ride inspection can help you monitor wear and deterioration before they become a problem. Correct any problems that you discover to reduce the risk of a breakdown or crash. See an authorized Can-Am On-Road dealer as necessary.

Before Activating the Vehicle, Inspect the Following:

<i>Item</i>	<i>Procedure</i>	
Weight	Ensure that total load on the vehicle (including operator, passenger, cargo and added accessories) does not exceed recommended load as indicated in the Technical Specifications, page 6-2 .	
Accessories	Ensure that the accessories are properly fastened to the motorcycle.	
Glove compartment and all service covers	Pull to check that it is properly latched. Refer to Glove Compartment, page 3-27 .	
Handlebar and brakes	Ensure vehicle is configured for the driver. Make sure all steering and brake components are properly tightened. Refer to Handlebar Adjustment, page 3-9 , Brake Lever Adjustment, page 3-4 and Brake Pedal Adjustment, page 3-6	
Brake fluid	Inspect and adjust brake fluid level. Refer to Brake Fluid Level Verification, page 4-9 .	
Brake lever	Validate that the driver is able to apply the full stroke of the brake lever. Refer to Brake Lever Adjustment, page 3-4 .	
Brake pedal	Validate that the driver is able to apply the full stroke of the brake pedal. Refer to Brake Pedal Adjustment, page 3-6 .	
Accelerator handle	Twist several times. Be sure it operates freely and returns to neutral position when released.	

<i>Item</i>	<i>Procedure</i>	
Coolant level	Inspect and adjust coolant level. Refer to Coolant Level Verification, page 4-12 .	
Leaks	Visually inspect the brakes, suspension, forks and coolant for any leaks. Refer to Maintenance Procedures, page 4-8 .	
Wheels	Ensure axle and lug nuts are properly tightened, inspect wheel spokes and look for damages. Refer to Wheels and Tires, page 4-15 .	
Tires	Look for damages. Verify tread wear. Check tire pressure. Refer to Wheels and Tires, page 4-15 .	
Suspension	Inspect shock absorber and forks for damages or leaks. Refer to Suspension Adjustment (Preload), page 3-67 .	
Mirrors	Clean and adjust. Refer to Mirrors, page 3-29 .	

Activate the Vehicle and Check the Following:

<i>Item</i>	<i>Procedure</i>	
Multifunction gauge	Check the indicators, the messages and state of charge. Refer to Multifunction Display, page 3-34 .	
Lights	Check operation of headlights, taillights, brake lights, license plate light and turn signal lights. Refer to Lights, page 4-23 .	
Horn	Check operation.	
Steering	Verify that handle bar operates freely. Refer to Handlebar, page 3-8 .	

<i>Item</i>	<i>Procedure</i>	
Stop switch	Check that the stop switch is working properly. Refer to Stop Switch Operation, page 3-17 .	
Sidestand	Check that the side stand switch is working properly, if the sidestand isn't moving smoothly, clean and grease sidestand bolt. Refer to Side Stand Operation, page 3-26 .	
Brakes	Slowly push the vehicle forward, then apply brakes with the brake lever/pedal individually to test. Refer to Brake System Inspection, page 4-11 .	
Accessories (if equipped)	Ensure that the accessories are properly latched.	
Cargo bags (if equipped)	Ensure that the cargo bags are properly latched.	
Passenger seat (if equipped)	Ensure that the passenger seat is properly latched.	
Footpegs (if equipped)	Make sure passenger's footpegs can be completely deployed.	
Handholds (if equipped)	Check solidity of the passenger handholds.	

3 VEHICLE INFORMATION - TABLE OF CONTENTS

PRIMARY CONTROLS	3-2	MULTIFUNCTION DISPLAY	3-34
Accelerator Handle	3-2	Multifunction Display Location	3-34
Brake Lever	3-3	Multifunction Display Operation	3-34
Brake Pedal	3-6	Multifunction Display Cleaning	3-49
Handlebar	3-8	ELECTRIC VEHICLE (EV) OVERVIEW	3-50
SECONDARY CONTROLS	3-10	High Voltage Components	3-50
Key Switch	3-10	Charging Port	3-51
Multifunction Switch	3-12	Lithium-Ion High-Voltage Propulsion Battery	3-52
Start Button	3-16	Vehicle Recharge	3-54
Stop Switch	3-16	OPERATING THE VEHICLE	3-58
BODY AND SEAT	3-18	Starting the vehicle	3-58
Driver Seat	3-19	Ready to Move Mode	3-59
Driver Footrests	3-21	Switching to and from Reverse	3-60
Handgrips	3-23	Drive Modes	3-60
Rear Lower Side Fairing (if equipped)	3-23	Regen modes	3-63
Rear Upper Fairing	3-25	Turning OFF the Vehicle	3-64
Side Stand	3-26	TUNE YOUR RIDE	3-65
EQUIPMENT	3-27	Suspension Adjustment Guidelines	3-66
Glove Compartment	3-27	Suspension Adjustment (Preload)	3-67
LinQ System	3-28	Damping Adjustment	3-70
Mirrors	3-29		
Operator's guide	3-30		
USB Port	3-31		
Windshield (if equipped)	3-31		

PRIMARY CONTROLS

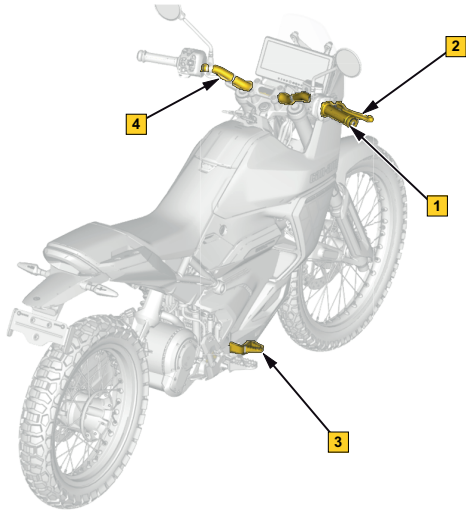

1. Accelerator Handle
2. Brake Lever
3. Brake pedal
4. Handlebar

Accelerator Handle

Accelerator Handle Location

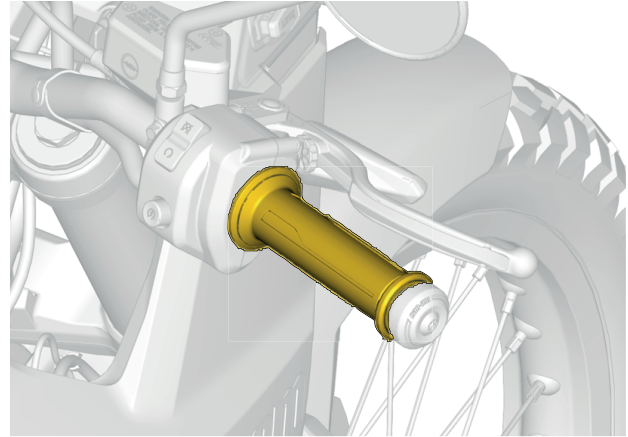

Accelerator Handle Operation

Rotate the right handgrip to operate the accelerator handle. This controls the vehicle's speed by controlling the electric motor.

To accelerate, rotate the accelerator handle towards you.

The acceleration responsiveness can be adjusted based on user preferences. Refer to [Drive Modes, page 3-60](#) for more information.

To decelerate using regen, release or rotate the accelerator handle away from you.

Always cover the front brake lever before rotating the accelerator handle away from you so as to always be able to use the brakes.

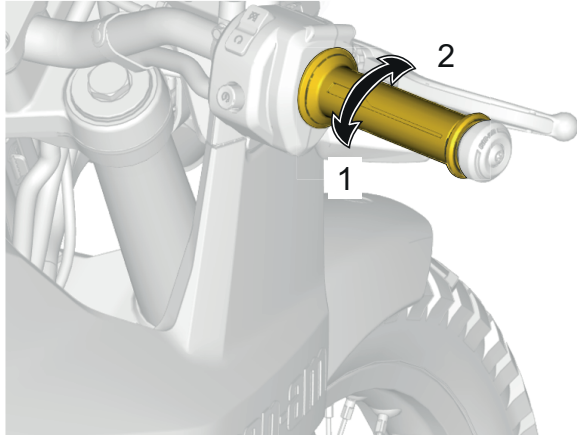

- 1. Acceleration
- 2. Regen

Regenerative braking will only work with the following conditions:

- The vehicle is in motion
- Regenerative braking is activated in the vehicle settings
- The accelerator handle is released or rotated away from you
- The high-voltage battery can store the generated energy

Regen responsiveness can be adjusted based on user preference. Refer to [Regen Modes, page 3-63](#) for more information.

Brake Lever

Brake Lever Location

The brake lever is located on the right side of handlebar. The brake lever controls the front brakes.

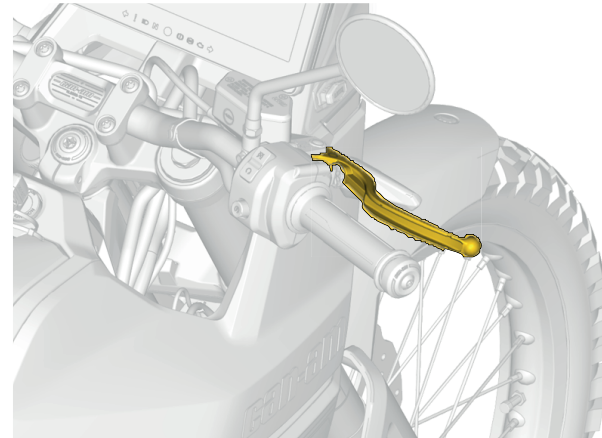

Brake Lever Operation

When brought toward the grip, the brake is applied. When released, it automatically returns to the rest position. Braking effect is proportional to the force applied on the lever up to a terrain-dependent limit.

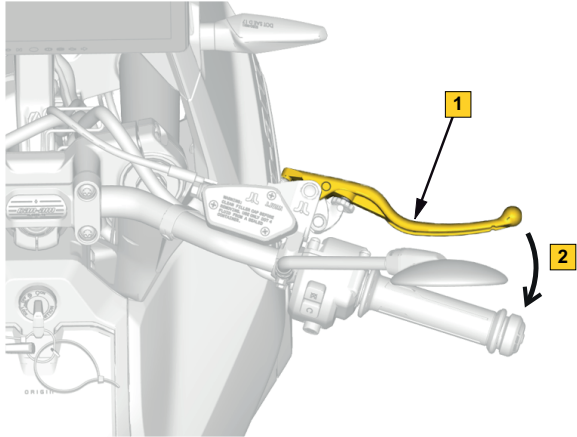

1. Brake lever
2. Brake application

Brake Lever Adjustment

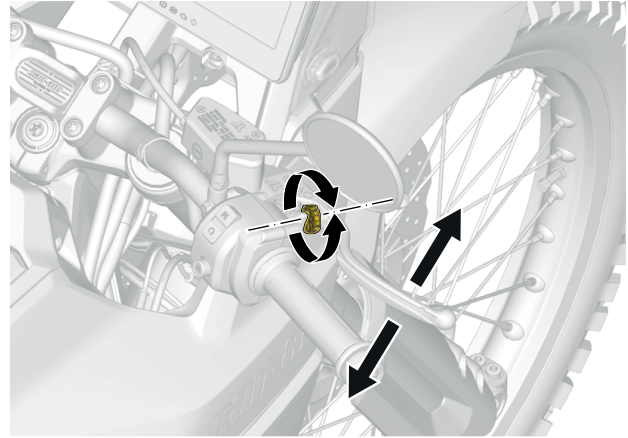

The position of the front brake lever can be adjusted by turning the adjustment wheel located at the beginning of the lever, between the lever and the accelerator handle. Turning the wheel clockwise or counter-clockwise will adjust the distance between the lever and the accelerator handle.

Front Brake Master Cylinder Reservoir Adjustment

1. Loosen the two bolts enough to easily move the brake lever/ brake master cylinder reservoir on the handlebar.

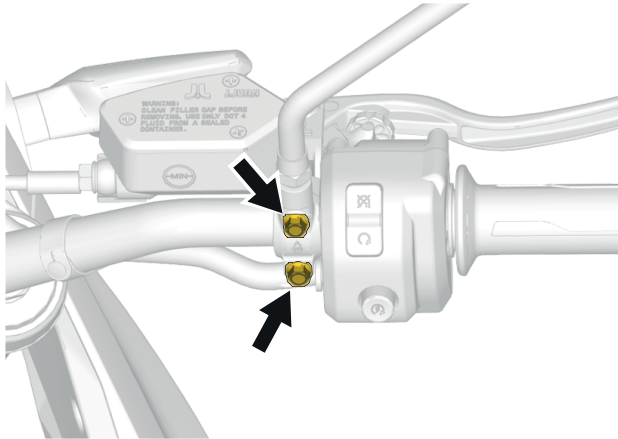

NOTE:
If the two bolts are not loosened enough, the brake lever can leave marks on the handlebar.

2. Locate the reference mark on the handlebar and respect the distance and rotation limits.

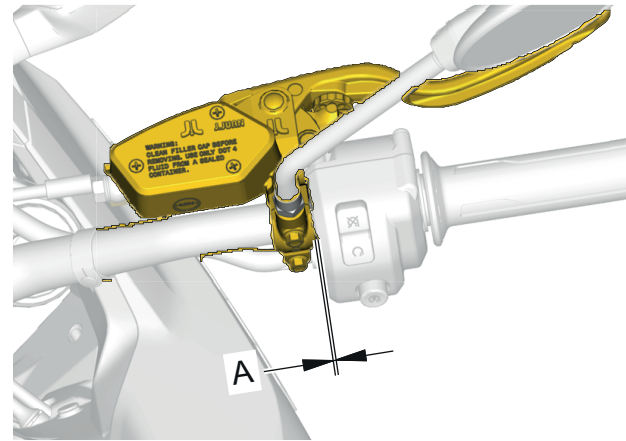

A. 0 to 5 mm (0 to 0.197 in) between the handlebar point and side of the brake lever.

3. With the operator on the driver seat, put the brake lever in the desired position. Make sure the brake reservoir or any other components do not contact any part of the vehicle at full steering lock in both directions.
4. Tighten the two bolts to specification.

TIGHTENING TORQUE	
Brake lever adjustment bolts	8.5 ± 1.5 Nm (75.23 ± 13.28 lbf-in)

Brake Pedal

Brake Pedal Location

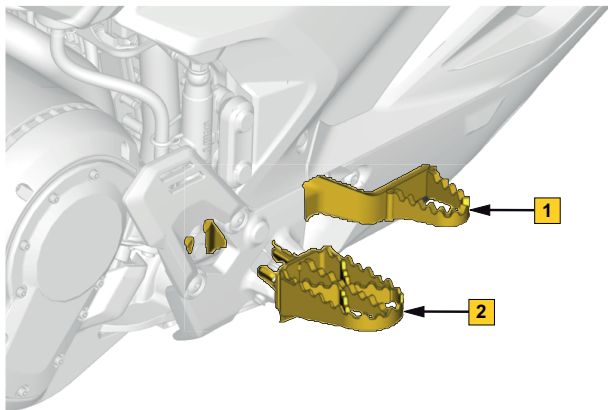

1. Brake pedal
2. Driver footrest

Brake Pedal Operation

The brake pedal is located along the right side of the driver footrest support. Press it down to operate. This pedal brakes the rear wheel.

NOTICE

When riding, make sure not to rest your foot on the brake pedal. This could cause the rear brake to overheat.

Brake Pedal Adjustment

1. Remove the RH side heel guard. Refer to [Heel Guard Removal, page 3-21](#).
2. Loosen the master cylinder fork nut.

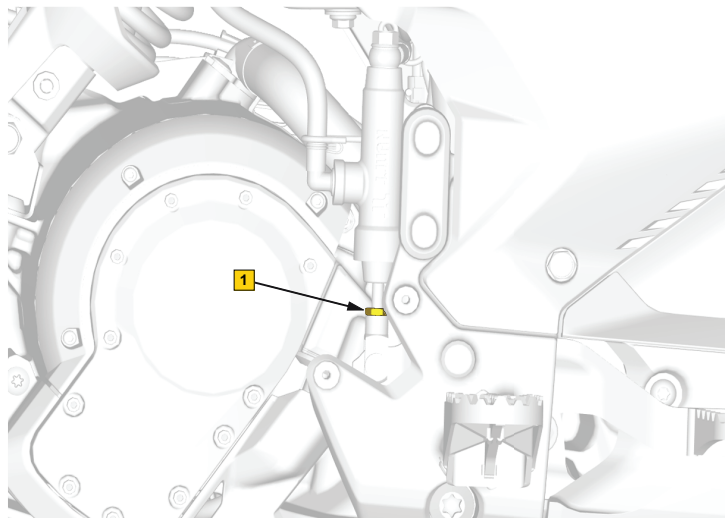

1. Master cylinder fork nut

- Remove the spring, cotter pin, washer and axle from the brake pedal.

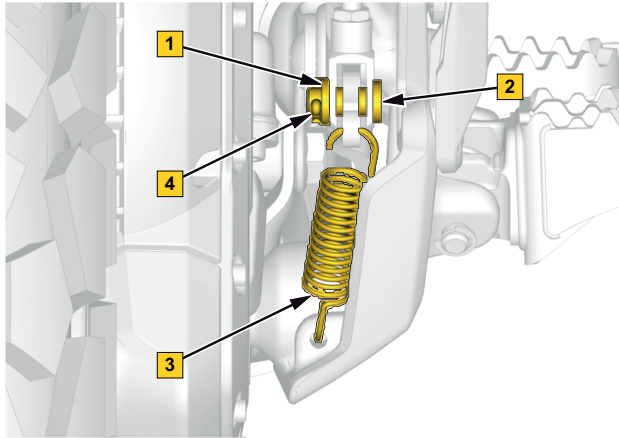

- Washer
- Axle
- Spring
- Cotter pin

- Disengage the brake pedal and rotate the master cylinder fork to adjust the length.
- Engage the brake pedal in the master cylinder fork and temporarily insert the axle and spring.

- Verify pedal adjustment is appropriate for driver's need and within tolerance, re-adjust as required.

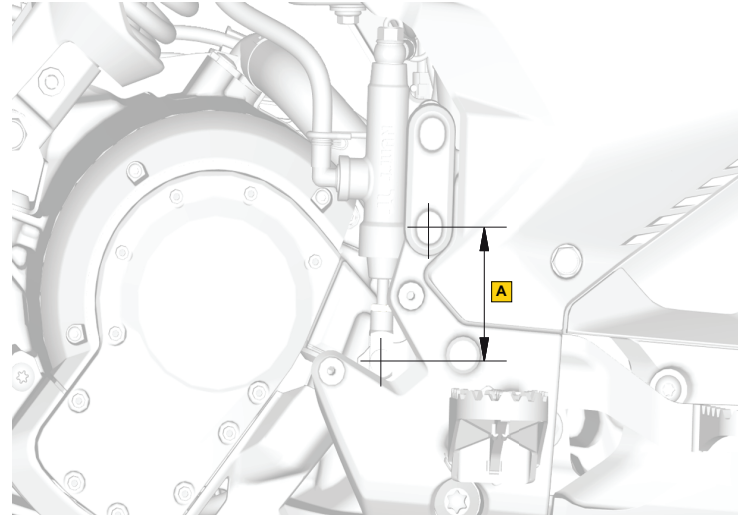

A. Adjustment tolerance $67.5 \pm 3 \text{ mm}$ ($2.56 \pm 0.12 \text{ in}$)

- Tighten the master cylinder fork nut to specification.

Tightening Torque	
Master cylinder fork nut	$5.5 \pm 1.5 \text{ Nm}$ ($4.07 \pm 1.11 \text{ lbf-ft}$)

8. Install the spring, axle, washer and cotter pin to the brake pedal.

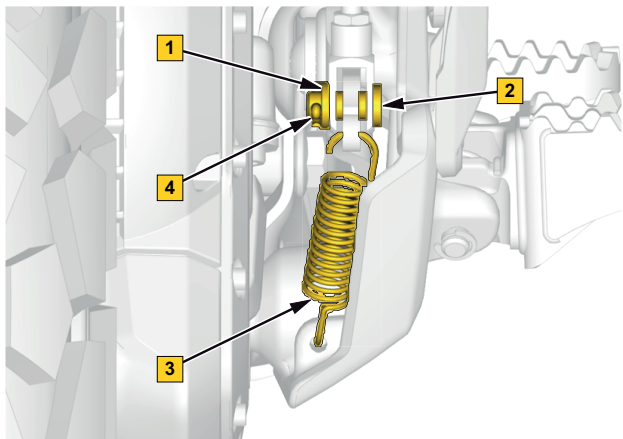

1. Washer
2. Axle
3. Spring
4. Cotter pin

9. Install the RH side heel guard. Refer to [Heel Guard Installation, page 3-22](#).

Handlebar

Grip the handlebar with both hands while riding the motorcycle. The Handlebar can be adjusted according to user preferences. Refer to [Handlebar Adjustment, page 3-9](#).

Handlebar Location

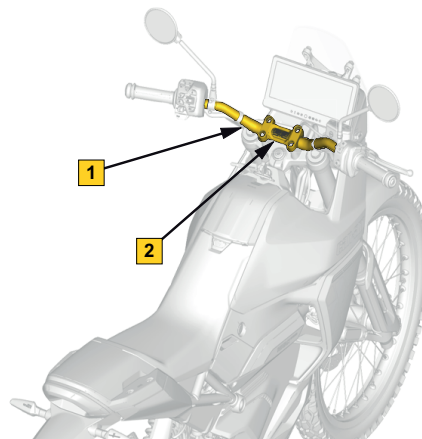

1. Handlebar
2. Handlebar support

Handlebar Adjustment

WARNING

The handlebar, the brake lever and brake pedal can be easily adjusted to meet each driver needs.

It is important that all controls must be fully accessible and easily usable by the person driving the vehicle at all times.

Take time to adjust the vehicle to the driver before riding.

Make sure the vehicle is turned off and the stop switch is on the STOP position before performing any control components adjustments.

1. Loosen the four fasteners enough to easily rotate the handlebar from the upper support.

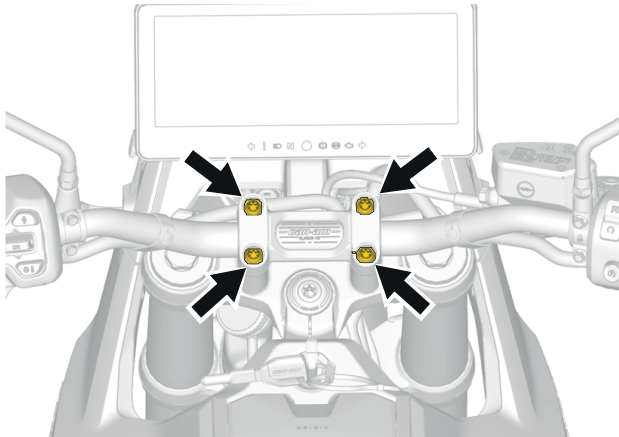

2. With the operator on the driver seat, rotate the handlebar in the desired position.
3. Before tightening the handlebar support fasteners, check that the pad printing is perfectly centered, as shown in the figure.

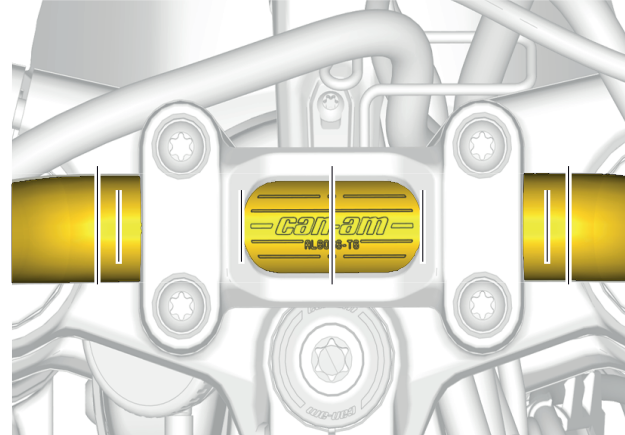

4. Tighten the four fasteners to specification.

TIGHTENING TORQUE

Handlebar upper support fasteners

24.5 ± 3.5 Nm (18.07 ± 2.58 lbf-ft)

SECONDARY CONTROLS

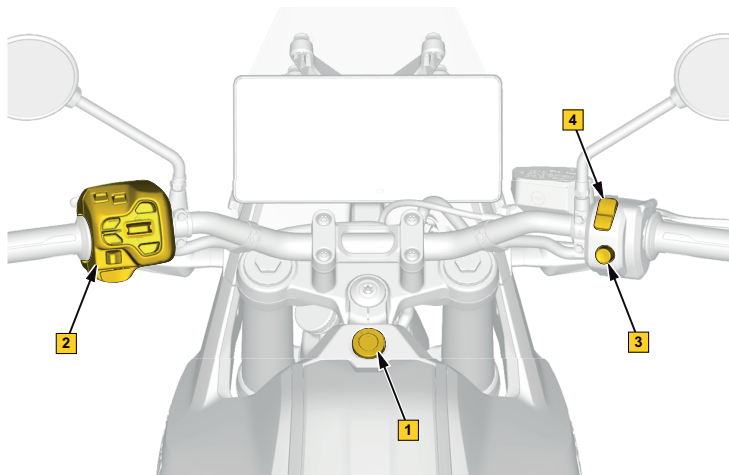

1. Key switch
2. Multifunction switch
3. Start button
4. Stop switch

Key Switch

Key Switch Operation

OFF

The key can be inserted or removed in this position.

In the OFF position, the electrical system of the vehicle is disabled.

ON

When the key is turned to this position, the electrical system of the vehicle is activated.

The multifunction display will turn on.

The vehicle lights will turned on.

The propulsion system can be enabled.

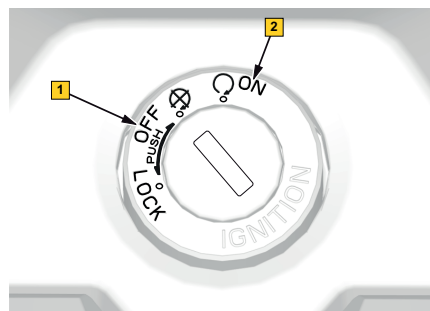

1. OFF
2. ON

NOTICE

If the key does not turn easily, do not force it. Pull it out and reinsert.

⚠ WARNING

If you turn the key switch to OFF while moving, the electrical system will still be active but the propulsion system and the horn will be disabled. The propulsion system cannot be switched to ON while moving if it was disabled by turning the key to off. In this case, the motorcycle will need to be stopped at a safe place and the sequence for starting will need to be executed in order to resume.

Two keys are provided with your vehicle. Store the spare key and the key tag in a safe place because you **must** have your spare key or your key tag to have another one made by an authorized Can-Am On-Road dealer.

Handlebar Lock Operation

To lock the steering mechanism:

1. Insert key in the key switch at the OFF position.
2. Rotate the handlebar all the way to the right or to the left.
3. Push and turn the key 1/4 turn counterclockwise to the steering lock position.



Key position to lock handlebar

4. Remove key from the key switch.

To unlock the steering mechanism:

1. Insert the key, push it and turn it clockwise to the OFF position.
2. Remove the key.

Multifunction Switch

Multifunction Switch Location

The multifunction switch is located on the left side of handlebar.

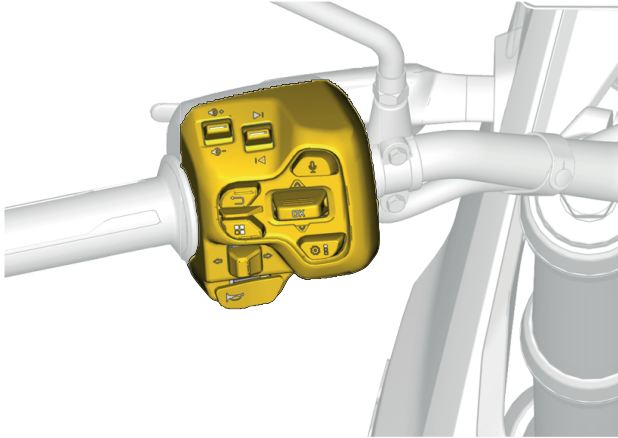

Multifunction Switch Operation

All the controls present on the multifunction switch only work when the key is in ON position.

Audio Controls

The audio controls buttons are located on the top left portion of the multifunction switch.

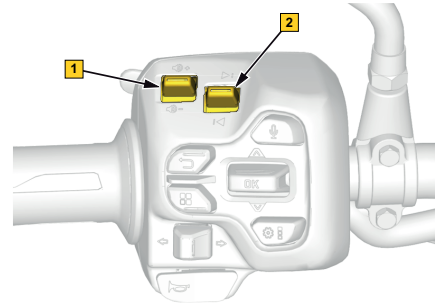

1. Volume Up / Down
2. Audio Prev / Next

Volume Up / Down

Use to adjust the volume of the vehicle audio system.



Audio Prev / Next

Use to go to the next or previous song or channel.

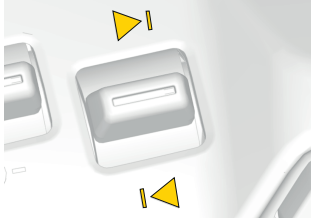

Headlight Switch

The headlight switch is located on the back of the left multifunction switch.

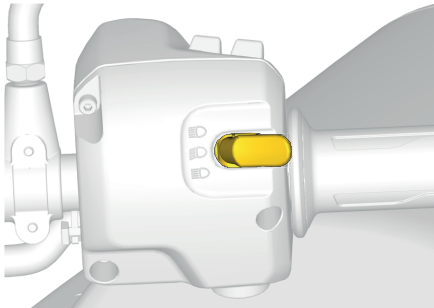

The switch is used to activate and deactivate the high beams. The low beams automatically turn on when the vehicle is activated and turn off when the vehicle is turned off.

The icon  will appear inside the multifunction display when the headlight is turned on.

To activate high beams, push the switch to the front position. To deactivate high beams, push the switch backward to the neutral position.

To flash the high beams, press the switch fully in, then release it. The high beams will stay on as long as you hold down the switch and will return to low beams once the neutral position is restored.

Horn Button

The horn button is located at the bottom of the left multifunction switch.

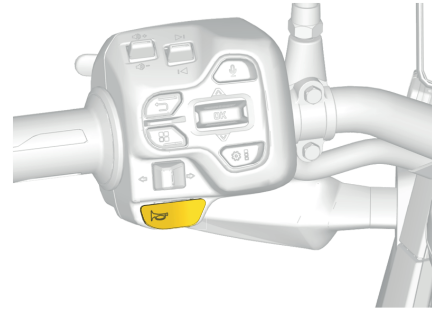

Press the button to activate the horn.

NOTE:

Horn can only work when the key switch is in the on position.

Multimedia Controls

The multimedia controls buttons are located in the center of the multifunction switch.

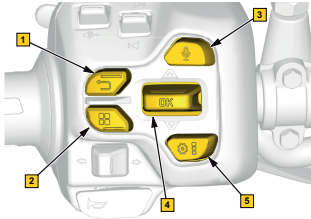

1. *Back Button*
2. *Applet Switcher Button*
3. *Voice Assistant Button*
4. *OK / Select Button*
5. *Ride Settings Button*

Back Button

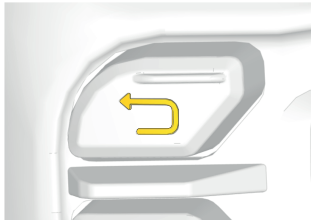

Used to return to the previous page/menu.

Applet Switcher Button

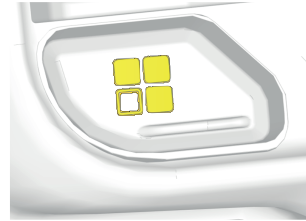

Used to change applets configured in the Applet Switcher manager menu.

- Phone
- Media
- Statistics
- Apple CarPlay
- Navigation App

Voice Assistant Button



Used to trigger the voice assistant of the phone. The operator must have a phone and a headset connected via Bluetooth to use this function.

OK / Select Button



Move the button up or down to navigate through the multifunction display options.

Press in the button to accept a choice or a command.

Ride Settings Button

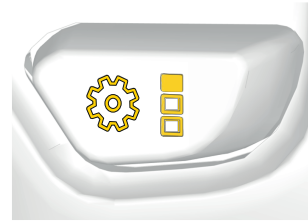

Quick access to change between ride setting menus.

Turn Signal Button

The turn signal button is located on the lower left portion of the multifunction switch.

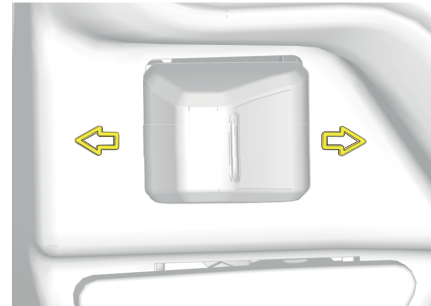

One of the following icon ( ) appears inside the multifunction display when the turn signal is activated.

The turn signal button doesn't turn off automatically, you have to turn it off manually after a normal turn, a shallow turn or lane change.

To turn the signal off, press the button in.

Start Button

Start Button Location

The start button is located at the bottom of the right side multifunction switch.

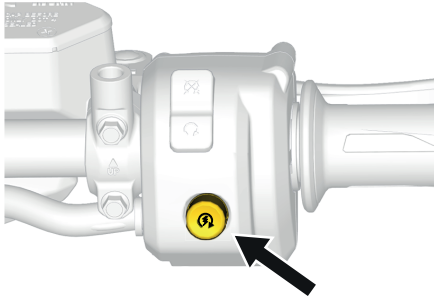

Start Button Operation

The start button is used to start the vehicle and change from Drive to Reverse mode, when depressed.

Ensure the start button operates freely and return to its neutral position after being depressed.

Refer to [Operating the Vehicle, page 3-58](#) and [Switching to and from Reverse, page 3-60](#) for additional information.

Stop Switch

Stop Switch Location

The stop switch is located at the top of the right side multifunction switch.

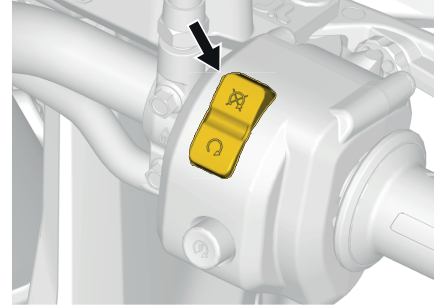

Stop Switch Operation

The stop switch is used to deactivate the vehicle propulsion system.

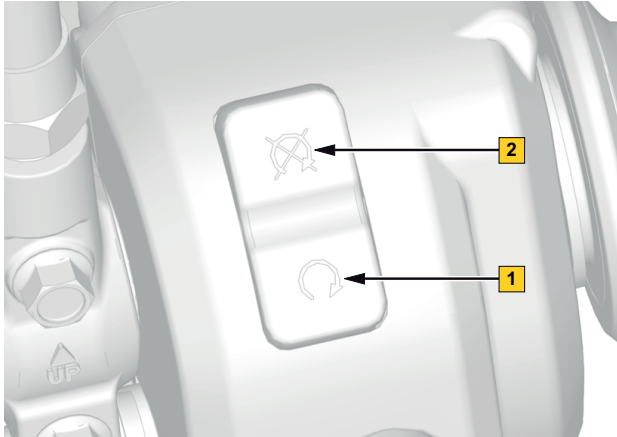

1. ON
2. OFF

The stop switch must be in ON (1) for vehicle propulsion system activation. It deactivates the propulsion system when in OFF (2).

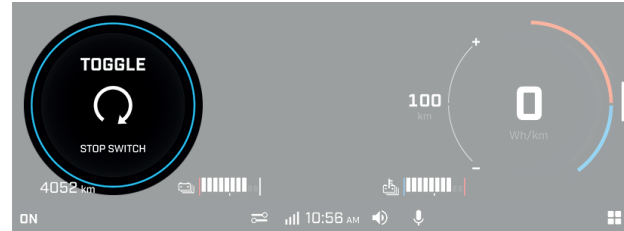

NOTICE

While the vehicle is in motion, the propulsion can be recovered if the latter has been disabled by the stop switch: the switch must set back to the ON position and the accelerator must be released.

Below a speed of 10 km/h, propulsion cannot be recovered and the operator will have to completely stop the motorcycle and do the activation sequence to resume the ride. Refer to [Operating the Vehicle, page 3-58](#).

BODY AND SEAT

Body Panels Location

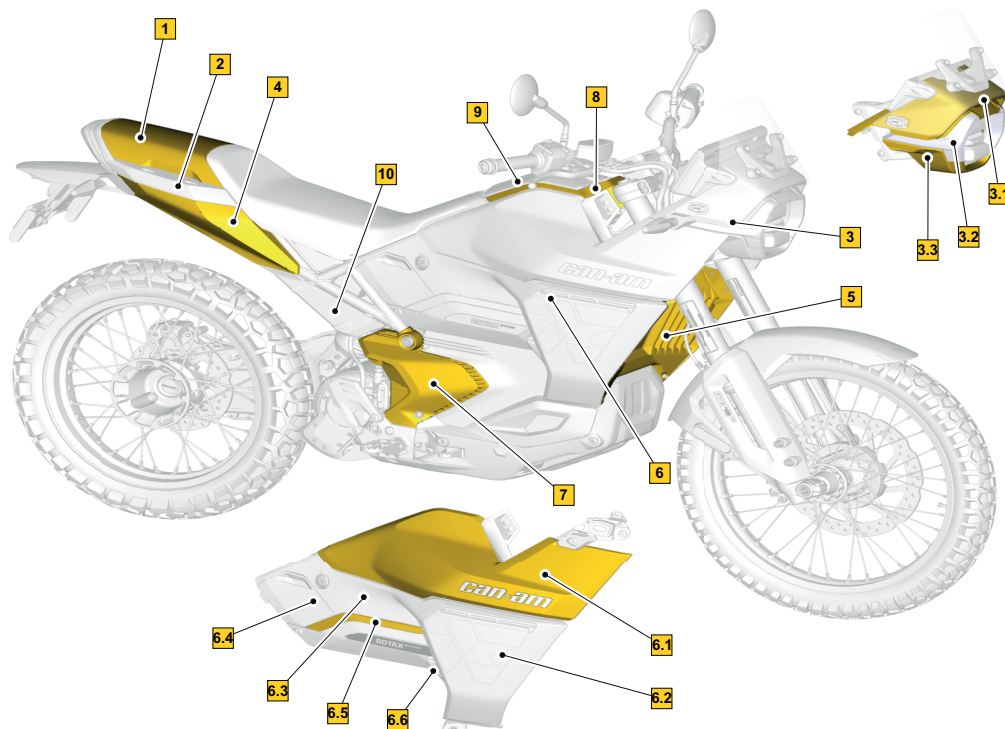

1. Rear upper fairing
2. Accessory support
3. Console
 - 3.1. Console upper fairing
 - 3.2. Signature Light (73 only) / Headlight side fairing
 - 3.3 Headlight lower fairing
4. Rear upper side fairing (73 only)
5. Grille
6. Side body panel assembly
 - 6.1. Side fairing
 - 6.2 Radiator fairing
 - 6.3 Central side fairing
 - 6.4 Charging port cover (RHS only)
 - 6.5 Side panel trim
 - 6.6 Air deflector
7. Lower body panel
8. Glove compartment (Central fairing)
9. Glove compartment cover
10. Rear lower side fairing (73 only)

Driver Seat

Driver Seat Cleaning

NOTICE

Do not use high-pressure washers (like the ones found in car washes) as they may damage certain parts of the vehicle.

To clean the driver seat:

1. Remove the driver seat from vehicle. [Driver Seat Removal, page 3-19](#).
2. Rinse the driver seat thoroughly with water to remove loose dirt.
3. Using a soft, clean cloth, wash the driver seat with water mixed with a mild detergent, such as soap specially formulated for motorcycles or automobiles.

⚠ WARNING

Do not apply a vinyl or plastic protector on the seats as the surface will become slippery and the operator or the passenger may slip off the vehicle.

4. Dry the driver seat with a chamois or a soft towel.
5. Install the driver seat on vehicle. Refer to [Driver Seat Installation, page 3-20](#).

Driver Seat Removal

1. Open the glove compartment.

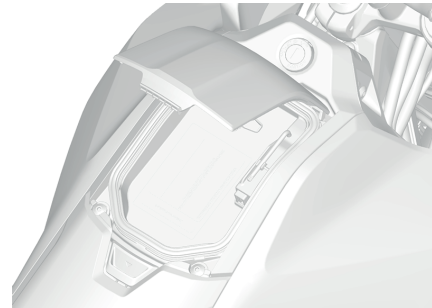

NOTICE

Pay attention to not force the glove compartment cover clips.

2. Remove the two front screws using the tool (A) located in the glove compartment.

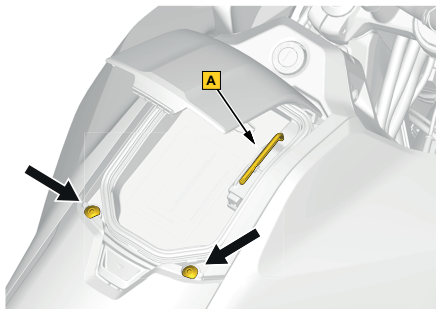

3. Lift the driver seat front end (1) and pull forward to disengage the rear hook (2).

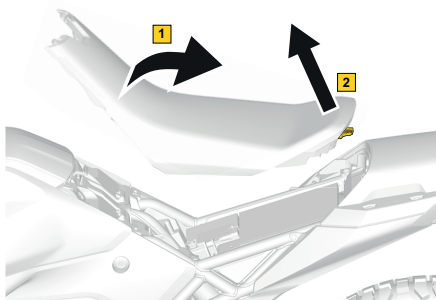

By removing the seat, the following features become accessible:

- 12V battery
- Fusebox
- BRP diagnostic connector
- OBDII diagnostic connector
- Operator's Guide
- Installation of some accessories
- First Respond Loop Connector

Driver Seat Installation

1. Engage the driver seat rear hook on the motorcycle (1) and lower the driver seat in position (2).

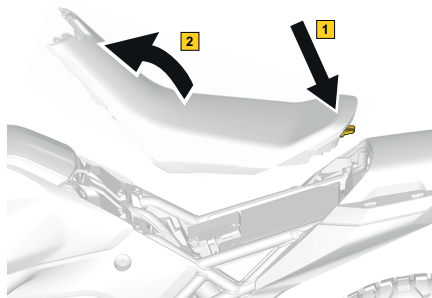

2. Install the two driver seat front screws and tighten to specification.

TIGHTENING TORQUE	
Front screws	2.5 ± 0.5 Nm (22.13 ± 4.43 lbf-in)

Driver Footrests

Driver Footrests Location

The driver footrests are installed on the footrest support.

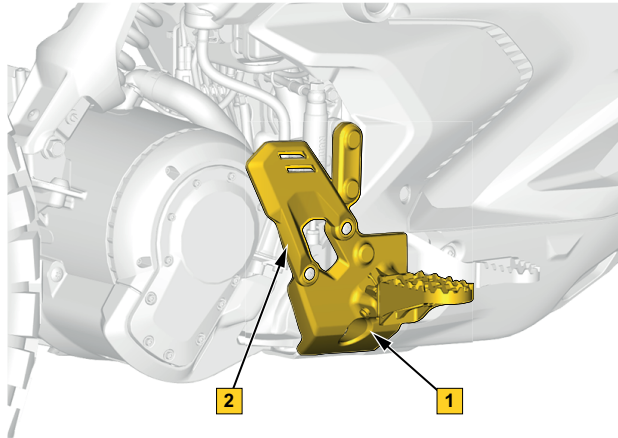

1. Right side footrest support
2. Heel guard

Driver Footrests Operation

Driver footrests are articulated and will move upward if they come in contact with the ground.

They are equipped with a spring to ensure they return to their original position after the upward movement.

⚠ WARNING

Do not alter driver footrests configuration, this can cause the driver footrests to move.

Heel Guard Removal

1. Remove the heel guard retaining screws.

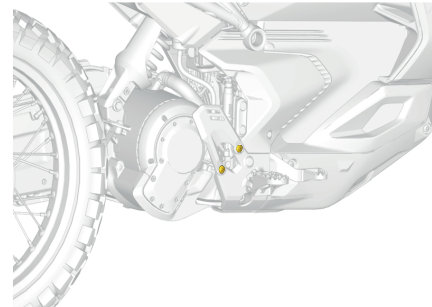

2. Remove the heel guard from the vehicle.

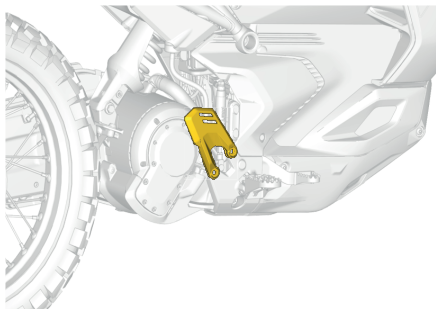

Heel Guard Installation

1. Install the heel guard on the vehicle.

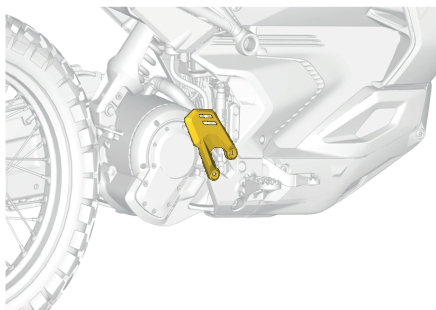

2. Install the heel guard retaining screws. Tighten to specifications.

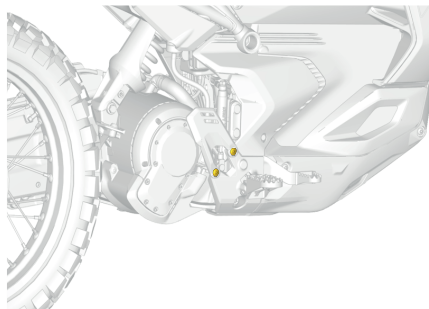

Tightening Torque	
Heel guard screws	3.25 ± 0.25 Nm (28.75 ± 2.25 lbf-in)

Handgrips

Handgrips Location

Handgrips are located on both sides of the handlebar.

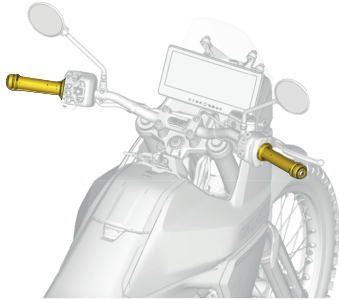

Handgrips Cleaning

NOTICE

Do not use high-pressure washers (like the ones found in car washes) as they may damage certain parts of the vehicle.

To clean the handgrips:

1. Rinse the handgrip thoroughly with water to remove loose dirt.

2. Using a soft, clean cloth, wash the handgrips with water mixed with a mild detergent, such as soap specially formulated for motorcycles or automobiles.

! WARNING

Do not apply any protectant for vinyl or plastic. These products leave the surface slippery, the driver need a firm grip when riding.

3

3. Dry the handgrips with a chamois or a soft towel.

Handgrips Inspection

1. Clean the handgrips. Refer to [Handgrips Cleaning, page 3-23](#)
2. Check handgrips for:
 - Cracks
 - Bending
 - Other damages
 - Proper operation

Replace handgrips if required.

See an authorized BRP dealer for handgrips replacement.

Rear Lower Side Fairing (if equipped)

Rear Lower Side Fairing Removal

1. For RH side: Remove the two rear lower side fairing retaining screws and remove the RH fairing from the vehicle.

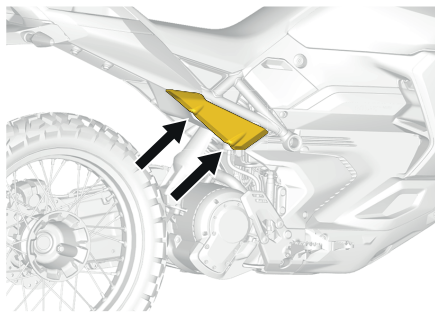

2. For LH side: Remove the two rear lower side fairing retaining screws and remove the LH fairing from the vehicle.

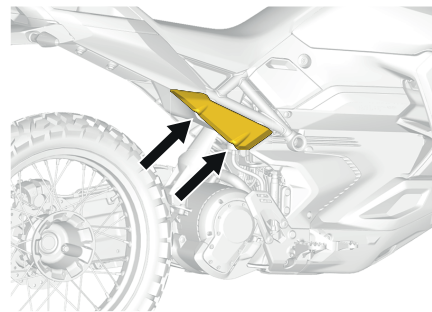

2. For LH side: Install the LH rear lower side fairings and the two rear lower side fairing retaining screws.

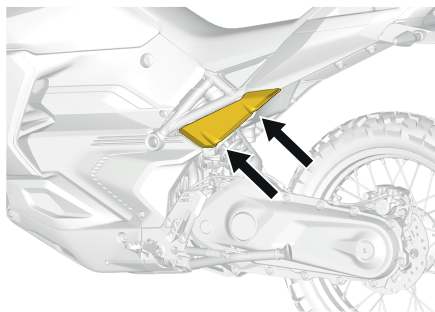

Rear Lower Side Fairing Installation

1. For RH side: Install the RH rear lower side fairings and the two rear lower side fairing retaining screws.

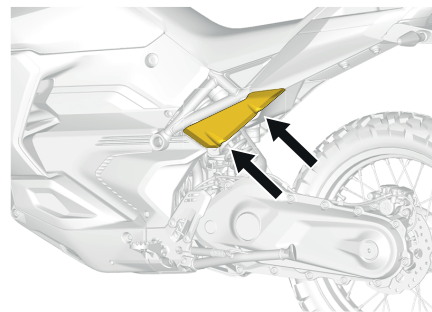

Tightening Torque	
Rear lower side fairing screws	9 ± 1 Nm (79.66 \pm 8.85 lbf-in)

Rear Upper Fairing

Rear Upper Fairing Removal

1. Open the glove compartment cover.
2. Remove the driver seat. Refer to [Driver Seat Removal, page 3-19](#).
3. To unlock the rear upper fairing, pull up the upper front center recess, and slide toward the front of the vehicle. Then pull it up to disengage the four hooks.

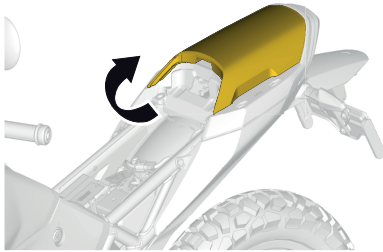

Rear Upper Fairing Installation

1. Make sure the four hooks are properly engaged. Slide the upper fairing toward the back of the vehicle until the front portion is locked in place.

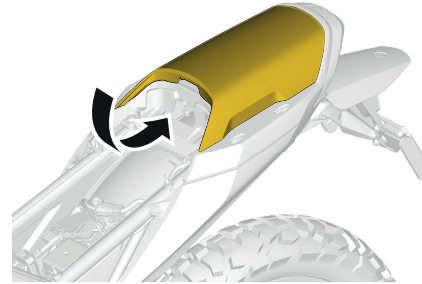

2. Install the driver seat. Refer to [Driver Seat Installation, page 3-20](#).
3. Close the glove compartment cover.

Side Stand

Side Stand Location

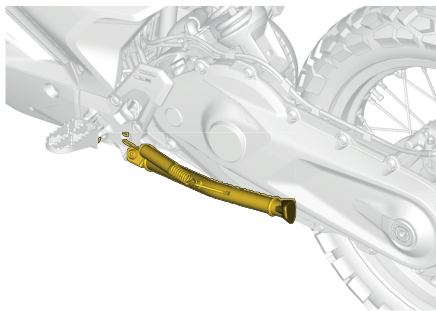

Side Stand Operation

The side stand swings out from the side and supports the motorcycle when parked. The key should be in the OFF position when parked.

The side stand is equipped with a sensor that monitors the position of the side stand and enables/disables the electric supply to the motor, based on the side stand position.

NOTICE

- When the side stand is deployed at a speed of 5 km/h and above, a notification is displayed in the multifunction display.
- When the side stand is deployed while the vehicle is moving at a speed below 10 km/h, the propulsion is deactivated.
- When the side stand is deployed while the vehicle is moving at speed of 10 km/h or above, propulsion is still active but in limited performance mode (power and speed are limited). This mode is maintained until an key cycle is performed.

EQUIPMENT

Glove Compartment

Glove Compartment Operation

The glove compartment can be used to protect a mobile device or other small belongings from the elements while riding. To open the glove compartment:

1. First ensure the handlebar is not locked to allow glove compartment opening.
2. Pull the switch toward the driver to open the glove compartment.

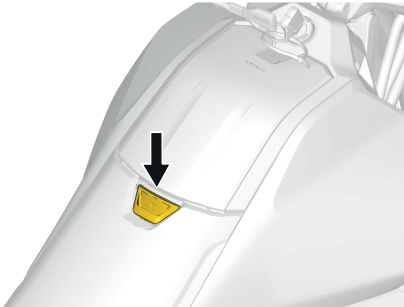

3. When done, close the cover.

NOTE:

Always latch the glove compartment after usage and do not leave personal belongings when leaving the motorcycle unattended.

Glove Compartment Cover Removal

1. Open the glove compartment.
2. Once fully open, pull the cover to release the hinges.

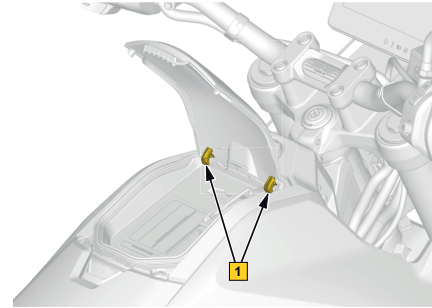

1. Hinges

3. Remove the cover.

Glove Compartment Cover Installation

1. Insert the glove compartment cover hinges.

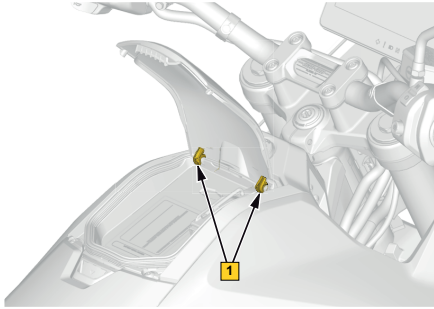

1. Hinges

2. Close the glove compartment.

LinQ System

LinQ System Location

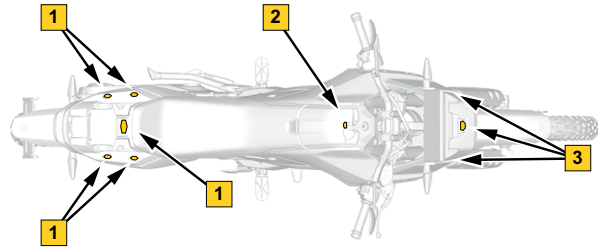

1. Accessory support LinQ System
2. Glove compartment LinQ System
3. Console LinQ System

LinQ System Operation

LinQ is a BRP-exclusive tool-free system for near-instant installation of accessories.

It allows for quick installation and removal of accessories by hand. It takes just seconds and it is completely secure.

The LinQ system holds up in every terrain and was designed to hold strong up to 4 G of force.

Refer to a Can-Am On-Road dealer to find accessories compatible with this vehicle.

Mirrors

Mirrors Adjustment

Each mirror can be adjusted to suit driver's preference by gently rotating it.

NOTICE

Do not try to turn the mirror arm. It must remain oriented vertically (upwards).

! WARNING

Do not adjust the mirrors while the vehicle is in motion.

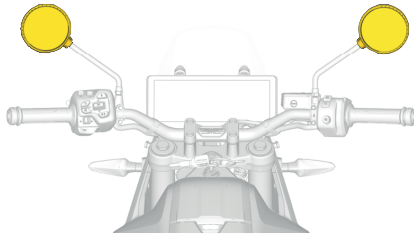

Mirrors Clamp Adjustment

1. For the RH side, loosen the two mirror clamp retaining screws.

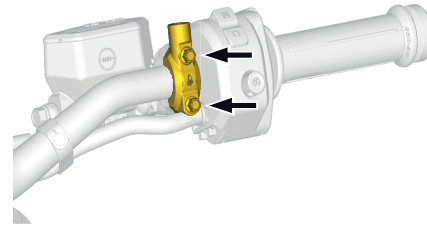

3

2. With the operator on the driver seat, rotate the mirror clamp in the desired position. The brake master cylinder is linked to the mirror clamp, rotating the mirror clamp will cause the rotation of the brake master cylinder. It is advisable to adjust both at the same time.
3. Tighten the two mirror clamp retaining screws to specification.

4. For the LH side, loosen the two mirror clamp retaining screws.

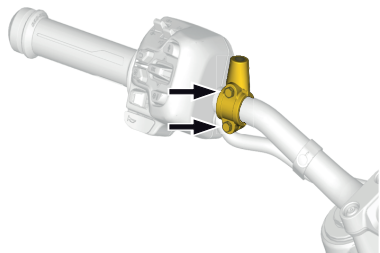

5. With the operator on the driver seat, rotate the mirror clamp in the desired position.
6. Tighten the two mirror clamp retaining screws to specification.

<i>TIGHTENING TORQUE</i>	
Mirror clamps retaining screws	2.75 ± 0.25 Nm (24.34 ± 2.21 lbf-in)

Operator's guide

Operator's Guide Location

The operator's guide is located under the driver seat.

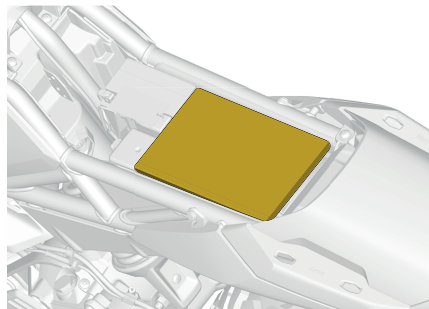

USB Port

USB Port Location

A USB port is located in the glove compartment.

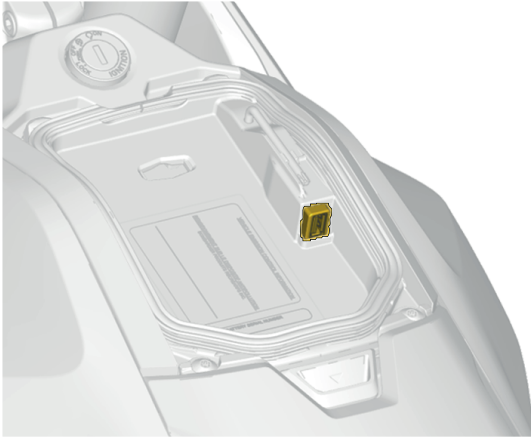

USB Port Operation

The USB port can be used for charging cellphone or any other devices (The maximum supply current is 2.1 amps).

The USB port must be used to run Apple CarPlay.

Windshield (if equipped)

Windshield Location



1. Windshield

Windshield Removal

1. Unclip both RH and LH nano linQ locks. Pull on the nano linQ center part.

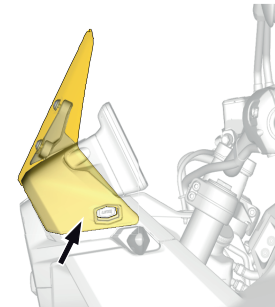

2. Place your hands on each side of the windshield.
3. Pull both sides of the windshield at nano linQ to unclip from the console.
4. Rotate the LinQ lever.

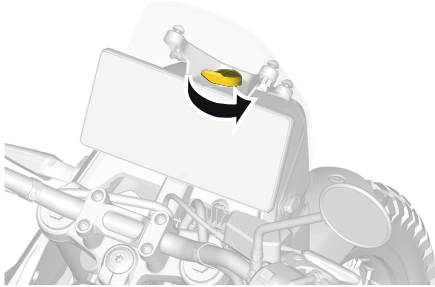

5. Remove the windshield from the console.

Windshield Inspection

⚠ WARNING

Polycarbonate windshields must never be repaired by welding or otherwise.

1. Check the windshield for:
 - Cracks
 - Proper installation
 - Fasteners torque

2. Replace the windshield and fasteners if required.

TIGHTENING TORQUE	
Windshield retaining screws	3.25 ± 0.25 Nm (28.75 ± 2.21 lbf-in)

Windshield Installation

1. Install the windshield on the console.
2. Rotate the LinQ lever.

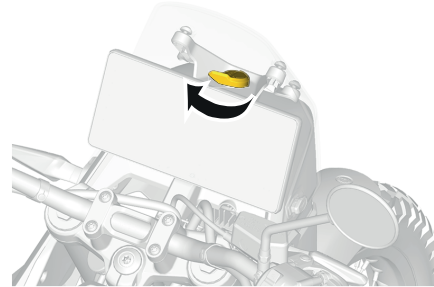

3. Place your hands on each side of the windshield.
4. Push both sides of the windshield at nano linQ to clip on the console.

5. Clip both the RH and LH nano linQ locks. Push on the nano linQ center part.

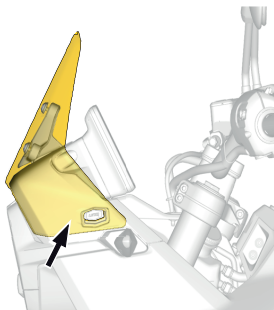

MULTIFUNCTION DISPLAY



Reading or operating the multifunction display can distract you from the operation of the vehicle, particularly from constantly scanning the environment. Always pay attention to road conditions and ensure your environment is clear and free from obstacles. Furthermore, when riding, only glance at the multifunction display briefly to maintain awareness of road conditions.

The multifunction display includes digital gauges (speedometer and performance gauge), telltales, indicators, controls and an infotainment center with a digital touchscreen.

We recommend you practice selecting some functions on the infotainment center before starting your ride. You will get used to them and they will be easier to use during the ride.

The touchscreen is deactivated as soon as the vehicle is moving.

When the vehicle is moving, only the left handlebar multifunction switch can be used to navigate through the menus and functions of the display.

Pressing the **Applet Switcher** button on the left handlebar multifunction switch will allow you to cycle through the applet in the right lateral display, in the order that can be defined in the preferences.

Multifunction Display Location

The multifunction display is located on the upper part of the console.

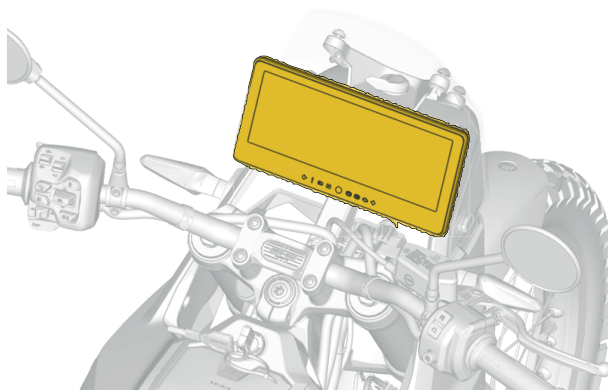

Multifunction Display Operation

Default Display

Light Mode

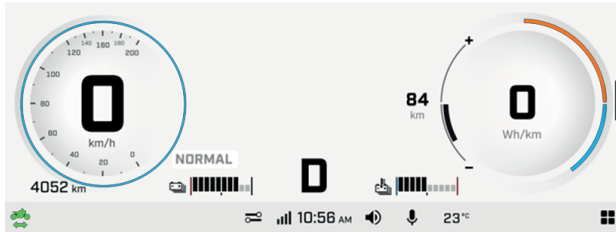

Dark Mode

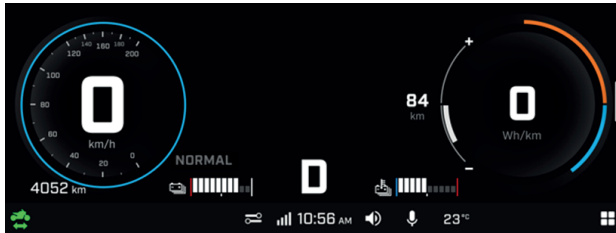

Full View Display

Left Lateral Display

In full view mode, the left lateral display includes:

- Drive Mode
- Speedometer
- Trip meter

Long press the trip meter (A) to show one of the following options. Cycle through the options with additional long presses.

- Vehicle total distance
- Trip A distance
- Trip A hours
- Trip B distance
- Trip B hours
- Vehicle total hours

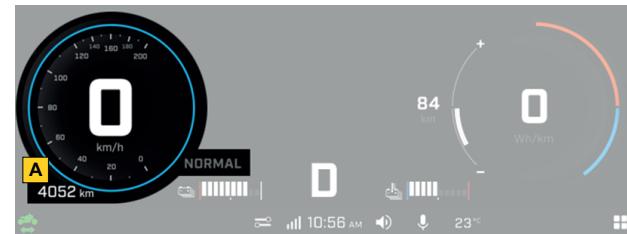

Center Display

In full view mode, the center display includes:

- High-voltage battery state of charge
- Drive selection (Drive or Reverse)
- High-voltage battery temperature

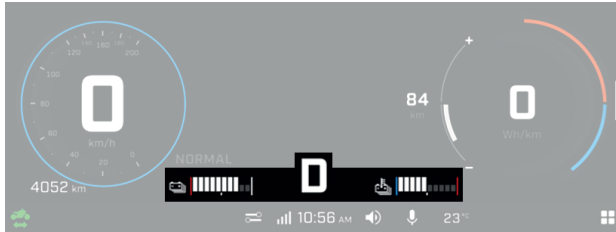

Right Lateral Display

In full view mode, the right lateral display includes the performance gauge. The performance gauge contains crucial information on the vehicle autonomy and energy consumption

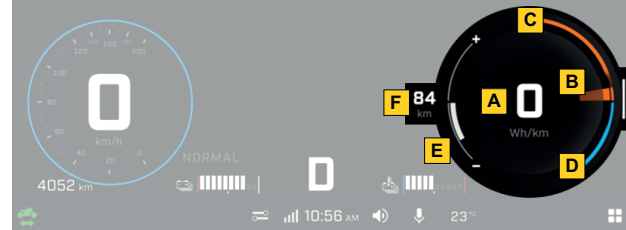

- A. Instant energy consumption*
- B. Current performance*
- C. Discharge limit*
- D. Regen limit*
- E. Range confidence level*
- F. Vehicle range*

The range can be displayed on the left or at the center of the performance gauge. To change the displayed information, long press in the center of the performance gauge. If the range is displayed on the left side, the instant energy consumption is displayed at the center of the performance gauge. The range adjusts automatically depending on usage and operating conditions.

The thick curve on the right, which varies instantaneously on both the discharge and regen portions, represents the actual usage of the vehicle power unit. The outer thin lines on the right indicate the maximum available performance, which may be influenced by factors such as the propulsion battery state of charge and the power unit temperature. Any limitation will cause them to be partially shaded.

The confidence level is displayed with a white bar on the left side of the performance gauge when the range is displayed in the center of the performance gauge and when the icon  is displayed.

Narrow View Display

To change from full view to narrow view, open an applet or slide the divider on the right side.

To change back to full view, long press on applet switcher or slide the divider back in place.



The size of the left and right lateral displays cannot be adjusted.

Left Lateral Display

In narrow view, the left lateral display includes:

- Drive selection (Drive or Reverse)
- High-voltage battery state of charge
- High-voltage battery temperature
- Vehicle range
- Speedometer and performance gauge
- Trip meter

Long press the trip meter to show one of the following options. Cycle through the options with additional long presses.

- Current ride distance
- Trip A distance
- Trip A hours
- Trip B distance
- Trip B hours
- Current ride hours

Right Lateral Display

In narrow view, the right lateral display includes various apps.

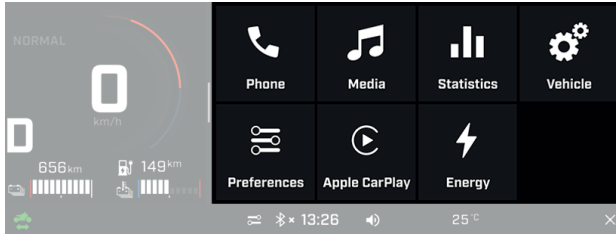

Refer to [Applet Menu, page 3-38](#) for more information.

Applet Menu

To access the applet menu, press the applet menu icon on the bottom-right corner.

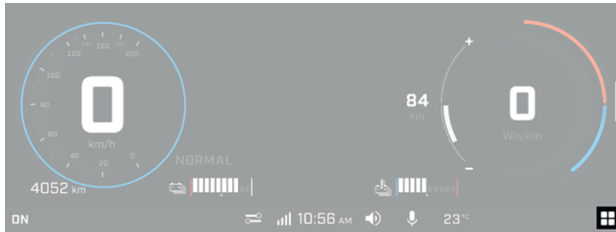

Press on an applet icon to open it.

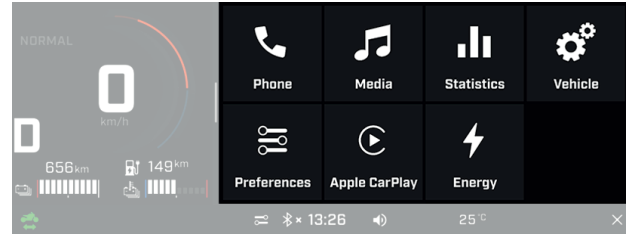

Phone

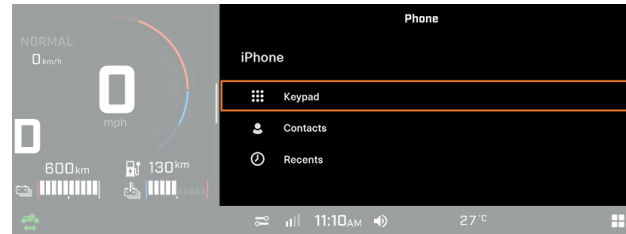

The Phone applet menu is used to access the:

- Keypad
- Phone contact list
- Phone history

NOTE:

To have access to the Phone menu, a phone and rider helmet (Headset) must be paired. Refer to [Bluetooth Connection, page 3-45](#).

Media

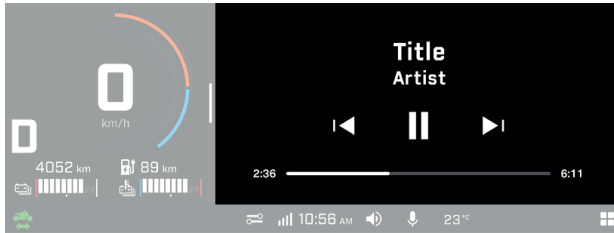

The Media applet is used to:

- Control song choice in the helmet audio system
- View song information (when available)

This vehicle is not equipped with speakers. An appropriate helmet audio system is required to listen to music.



Volume can be adjusted using the multifunction switch or the status bar volume icon on the touchscreen.

Statistics

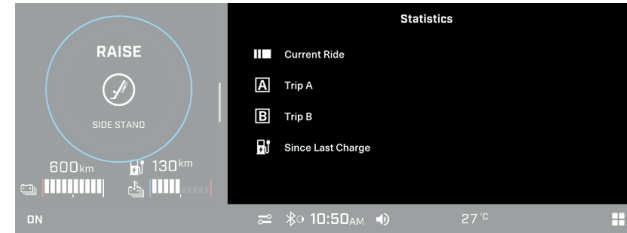

The Statistics applet is used to access:

- Trip distance information
- Trip elapsed time information
- Average speed
- Average energy consumption

Four sets of statistics are stored in memory. Trip A and Trip B can be reset independently. Current ride statistics will be reset when the vehicle is restarted. Since last charge statistics will be reset when the vehicle is recharged.

Vehicle Settings

The Vehicle applet is used to:

- Selecting drive mode:
 - Off-road+
 - Off-road
 - Sport
 - Normal
 - Rain
 - Eco

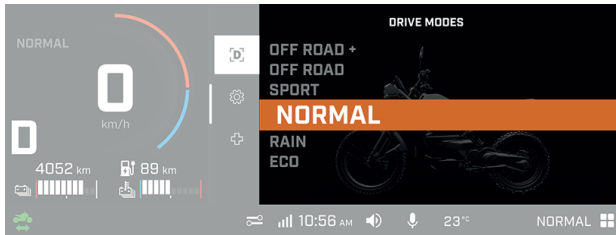

- View vehicle settings, including:
 - Traction control
 - Regen modes

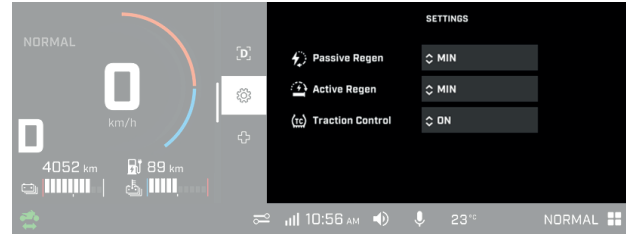

- View vehicle health, including:
 - Vehicle information
 - Faults (codes and description)

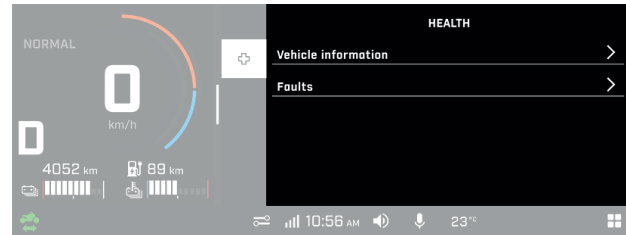

Preferences

The Preferences applet is used to:

- Adjust the display brightness and appearance (Light/Dark/Auto)
- Pair Bluetooth devices:
 - Phone
 - Driver headset
 - Passenger headset
- Connect the vehicle to a Wi-Fi network
- Access general settings:
 - Adjust the units (Imperial/Metric)
 - Set the language
 - Set the date and time
 - Perform a software update
 - Get information about manufacturer information and device regulatory compliance
 - Reset to factory settings
- Define the applets to be used with the applet switcher button while riding

It is recommended to check for software updates regularly.

Apple CarPlay

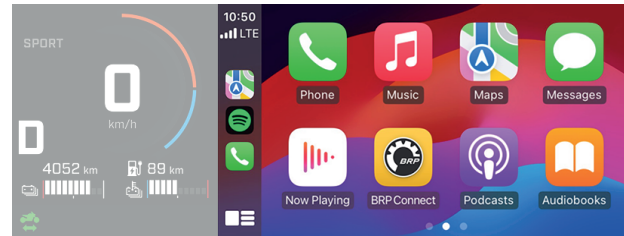

The Apple CarPlay applet is used to display the information from compatible mobile device applications such as:

- Media
- Messages
- Navigation
- Phone

This vehicle is not equipped with speakers. An appropriate helmet audio system is required to use Apple CarPlay.

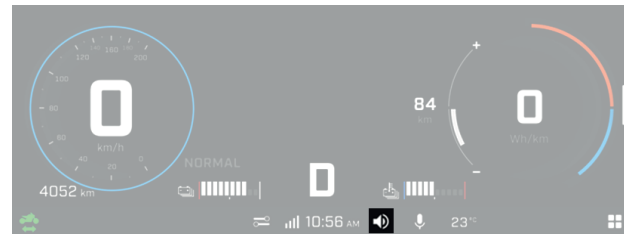

Volume can be adjusted using the multifunction switch or the status bar volume icon on the touchscreen.

Navigation App

To use the Navigation app on the display, you must connect (USB connection) a mobile device compatible with *Apple CarPlay*.

NOTICE

The smartphone must be connected with a USB cable to the USB port located in the glove compartment.

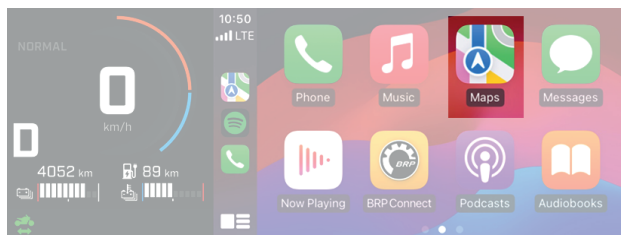

The user agrees that personal data (contact list and call history) will be transferred to the multifunction display when device is connected.

A compatible device with an active data plan is required to use *Apple CarPlay*.

Energy

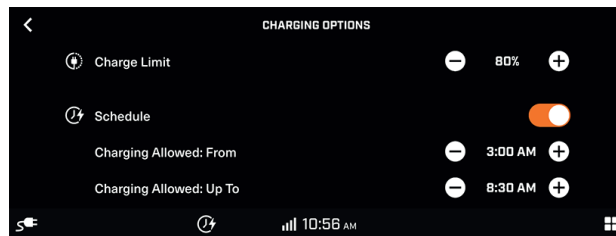

The Energy applet is used to access:

- Charging options display:
 - Charge limit
 - Schedule

It is also possible to access the charging option using the charging option icon when the vehicle is charging.

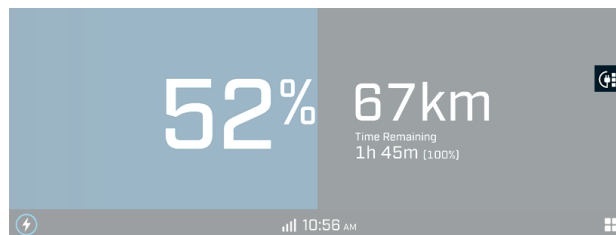

Quick Preferences

To access the Quick Preferences menu, press the following icon.

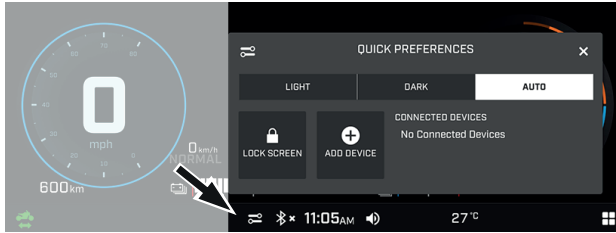

The Quick Preferences menu is used to:

- Adjust the display appearance (Light/Dark/Auto)
- Lock the screen (press and hold anywhere on the screen to unlock)
- Add a Bluetooth device
- View connected Bluetooth devices.

Warning Lamps and Indicators

The following indicator lamps will alert you to a vehicle condition that may become serious. Some lamps will illuminate when starting the vehicle to make sure they work. If any lamps remain on after starting the vehicle, refer to the respective system warning lamp for further information.



Some warning indicators appear in the display of the multifunction gauge and function the same as an indicator lamp but do not display when starting the vehicle.

Telltale

The telltales lights are found in two locations of the multifunction display:

- Physical bar
- Digital Touchscreen

Physical Bar

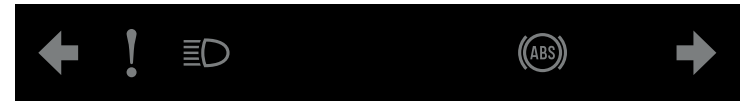





Pilot Lamps – 10.25” Color Digital Touchscreen

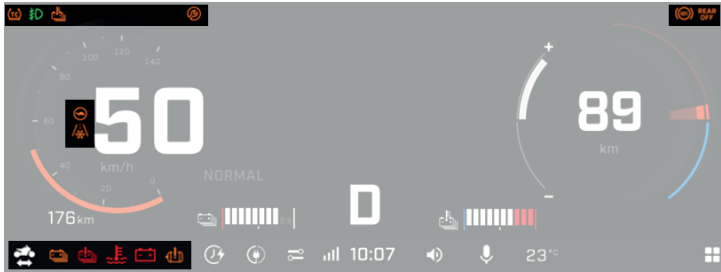









<i>Lights</i>	<i>Description</i>
	AMBER - Vehicle malfunction
	AMBER — ABS malfunction
	BLUE - High Beam activated
	GREEN — Left flasher activated
	GREEN — Right flasher activated
	GREEN — Hazard signal





Digital Touchscreen





DIGITAL PILOT LAMP - 10.25" COLOR DIGITAL TOUCHSCREEN





Lights	Description
	AMBER - Automatic power reduction due to a system malfunction
	GREEN - Fog lights are activated
	AMBER - Possible presence of ice on the roads
	AMBER - Traction control disabled by the rider (This light does not indicate a malfunction)
	AMBER - Traction control malfunction

Lights	Description
	AMBER — ON when the MTC system is not ready or malfunction.* Blinks when the MTC system is in active intervention.
	AMBER - Rear ABS is deactivated (This indicator comes on when the drive mode is set to OFF ROAD or OFF ROAD+)
	AMBER - Service is required
	AMBER — Propulsion battery overheat
	AMBER - Propulsion battery state of charge is low
	RED - Propulsion battery failure
	RED - Coolant temperature is high
	RED - 12V battery voltage is low
	AMBER - Electric motor failure
	WHITE - Vehicle connected to EVSE without charging

<i>Lights</i>	<i>Description</i>
	AMBER - Vehicle connected to EVSE and not charging due to a failure
	Vehicle actively charging
	Vehicle is energized and contactors are closed
	GREEN - Vehicle is stationary and ready to drive
	WHITE — Vehicle is moving at a speed higher than 5 km/h

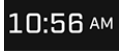
Icons and Indicators - Status Bar

<i>Icon</i>	<i>Description</i>
	Scheduled charge activated
	Charge limit activated
	Quick Preferences

<i>Icon</i>	<i>Description</i>
	Smartphone network connection
	Clock
	Audio volume
	Microphone
	Ambient temperature
	Applet menu

Bluetooth Connection

On the Vehicle

1. Open the Applet menu
2. Select "Preferences"

3. Select “Bluetooth”

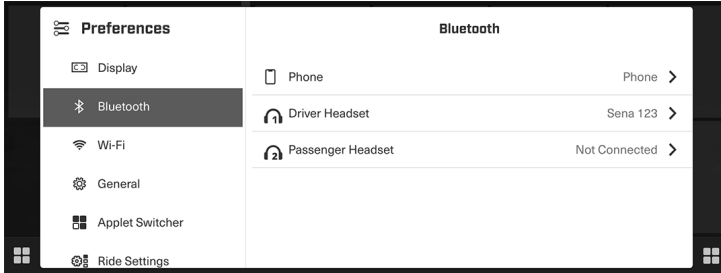

4. Select “Phone”

5. Select “Add Device”

NOTICE

More than one smartphone can be paired with the vehicle.
However, only one will connect at any given time.

On the Phone

1. Activate your phone's Bluetooth function.

Refer to your manufacturer's user guide for detailed procedure.

2. Select the name of your phone in the list of available devices.
3. A confirmation number will appear on the display and on the phone. Make sure that the numbers match.
4. Select Pair.

5. Allow Contacts and Favorite Sync.

Headset Bluetooth Connection

To pair a headset, refer to [Bluetooth Connection, page 3-45](#) and select “Driver Headset” or “Passenger Headset”.

Messages in Multifunction Display

Important information about your vehicle condition is displayed on the multifunction display. When starting the vehicle, always look at the display for any telltales and indicators or messages.

Important information messages can also be displayed temporarily to assist telltales and indicators.

Notifications will always appear at the top right corner of the screen.

There are two types of notifications:

- Vehicle notifications include warning, caution and notice messages
- Infotainment notifications include messages regarding connected devices

Vehicle notifications have priority over infotainment notifications when they are both present at the same time.

In the event that the vehicle goes into limited power mode, BRP recommends having the vehicle transported. If you operate the vehicle in limited power mode, avoid abrupt maneuvers and immediately go to the nearest authorized Can-Am On-road dealer to have your vehicle serviced before riding again. In limited power mode, power and vehicle speed are limited.

Apple CarPlay Connection

The Apple CarPlay connection is available using a USB connection (USB port is located in the glove compartment).

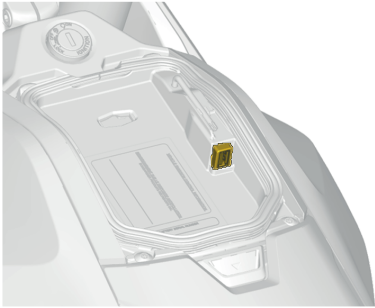

It is recommended to use an original USB charging cable from the smartphone OEM to optimize transfer between the phone and the vehicle, when using the USB port.

Make sure you accept the permissions requested on your phone. If certain permissions are not accepted, connection issues could result.

1. Unlock your phone.
2. Connect your phone using bluetooth or charging cable.
3. A checkmark will appear on your phone screen when the connection is successful.

BRP GO! App

1) Download the BRP GO! Smartphone App

Download the BRP GO! app via the App Store for Apple™ or the Google™ Play Store for Android.

2) Connect your smartphone using a USB cable

It is recommended to use an original USB charging cable from the smartphone OEM to optimize transfer between the phone and the vehicle. Use the front USB port.

Make sure you accept the permissions requested by BRP GO! on your phone. If certain permissions are not accepted, connection issues could result.

1. Unlock your phone
2. Connect your phone charging cable
3. A checkmark will appear on your phone screen when the connection is successful

3) Access your apps

Press the App Menu icon to access apps.

Select "Navigation."

Quick Tour of the BRP GO! App



1. Playground: Select your playground to see content related to your vehicle. For Can-Am vehicles, select the On-Road playground.
2. Connect to my vehicle: Easily access content on how to connect your device with to your vehicle's multifunction display.
3. Vibe: Connect your Vibe Communication system to your phone and manage many settings of your device in addition to being able to check the battery level.
4. Social: Create private communication groups (compatible only with Vibe communication systems)
5. FAQ: This link takes you to answers of common questions asked by riders like you. An internet connection is required.

Multifunction Display Cleaning

The multifunction display is a LCD display with glass finish and it is waterproof.

NOTICE

Do not use high-pressure washers (like the ones found in car washes) as they may damage certain parts of the vehicle.

To clean the multifunction display:

1. Using a soft, clean cloth, wash the multifunction display with water mixed with a mild detergent.

WARNING

Do not use abrasive cloth, they can damaged the multifunction display.

2. Dry the multifunction display with a soft towel.

ELECTRIC VEHICLE (EV) OVERVIEW

High Voltage Components

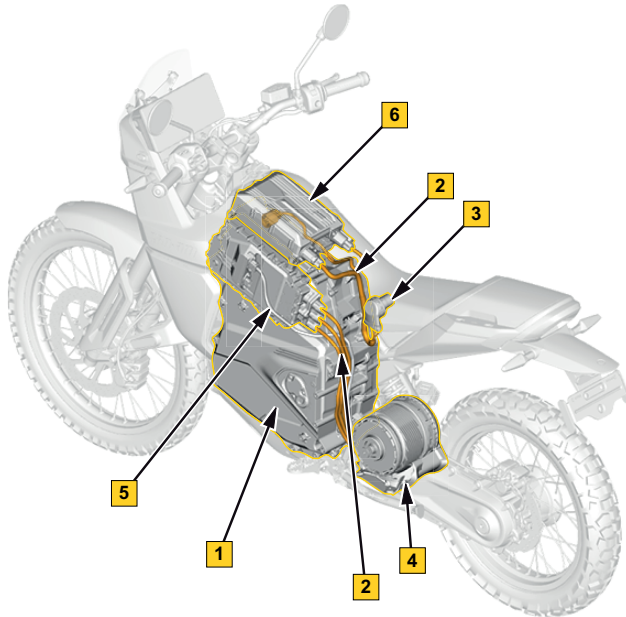

1. High-voltage battery
2. High-voltage cables
3. High-voltage charging port
4. High-voltage electric motor
5. High-voltage inverter
6. High-voltage on-board charger

High voltage cables can be identified on the vehicle by their orange color.

 **DANGER**

Do not manipulate, cut or otherwise damage the orange high-voltage cables. Always treat the orange high-voltage cables as if they were live and powered.

Typical

Charging Port

Charging Port Location

The charging port is located to the right side of the vehicle.

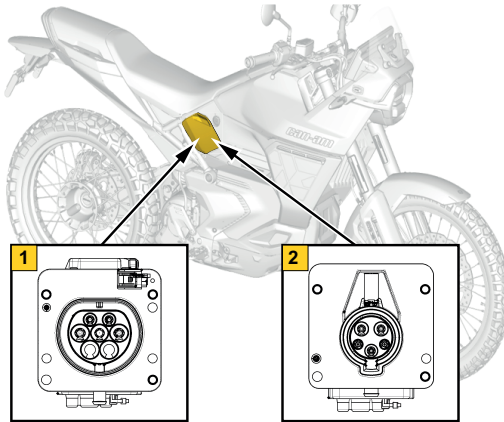

1. Charging port — Type 2 (IEC 62196)

2. Charging port — Type 1 (SAE J1772)

Charging Port Operation

The charging port can be accessed by opening the charging port cover. Depending on configuration, the vehicle may be equipped with a type 1 (SAE J1772) charging cable connector, commonly used in North America, or a type 2 (IEC 62196) charging cable connector used in Europe. A charging port adapter can be used to ensure proper communication between the vehicle charging system and the charging station (EVSE), if required.

The charging port is equipped with a draining hole to allow evacuation of water when the charging port cover is opened or being cleaned.

A current flow between the charging station (EVSE) and the vehicle can only occur if these conditions are met:

- The charging cable is connected and locked on the vehicle charging port.
- The vehicle cooling and charging systems are active.
- No electrical faults are present.

NOTICE

The vehicle charging system only accepts Level 1 (120V) or Level 2 (240V) charging. It is not compatible with Level 3 fast charging.

NOTE: If the 12V/low-voltage battery is faulty or other electrical faults are present, the vehicle charging system will not activate. The vehicle high-voltage battery state of charge (SoC) should be maintained between 20% and 80%. Refer to [Vehicle Recharge](#), page 3-54 for charging instruction.

Electric Vehicle Supply Equipment (EVSE)

The Electric Vehicle Supply Equipment (EVSE) cable used for charging the vehicle must be compatible with a type 1 (SAE J1772) or type 2 (IEC 62196) charging port connector, depending on vehicle configuration.

WARNING

Vehicles equipped with a Type 1 (J1772) charging connector shall only be charged with a CCID (Charge Current Interruption Device According to UL2231) equipped station.

WARNING

Vehicles equipped with a Type 2 (IEC 62196) charging connector shall only be charged with a RCD (Residual Current Device according to IEC61851) equipped station.

Depending on the region, charging can be done using Level 1 (120V) or Level 2 (240V) charging stations.

WARNING

Immediately disconnect the EVSE from the vehicle if plug or wall outlet is hot to the touch or emitting any unusual odors.

WARNING

Do not use extension cords or adapters with the EVSE.

WARNING

Do not use the EVSE if the plug does not have a proper connection with the wall outlet or if the wall outlet is rusted or damaged in any way.

WARNING

Do not use the EVSE if the cable or cord is frayed, has broken insulation or shows any other signs of damage.

Lithium-Ion High-Voltage Propulsion Battery

WARNING

The high-voltage battery should only be serviced by an authorized service technician. Do not open or tamper with the battery in any way. Contact an authorized BRP dealer for battery servicing.

WARNING

Do not use the high-voltage battery as a stationary power source or for other than its intended purpose in this vehicle.

NOTICE

Avoid fully discharging the high-voltage battery to 0%. The battery will engage a power/torque limiter when the state of charge is low. However, fully discharging the battery to 0% could damage the battery and render the vehicle inoperable. The battery cannot be recharged if it is highly depleted.

There are different electrical circuits in the system.

- DC high-voltage circuit: Links the battery, charger, inverter, providing energy to the vehicle propulsion system.
- 12V DC circuit: Used to power auxiliaries like control modules, lights and the infotainment.
- AC 120 V/ 240 V circuit: Used during charging.

The high-voltage and 12V circuits are linked through the DC-DC converter.

The high-voltage lithium-ion propulsion battery is comprised of multiple sealed cells that store the energy used to drive the vehicle.

During normal operating conditions, the high-voltage propulsion battery also provides charging current through the DC-DC converter to the auxiliary 12V battery. The 12V may also be charged when the vehicle is connected to an EVSE.

All batteries degrade over time. The high-voltage battery pack efficiency will vary in function of the service time and condition.

Battery Management System (BMS)

The high-voltage battery pack is equipped with a Battery Management System (BMS) that monitors the condition of the high-voltage propulsion battery. The BMS optimizes charging and under certain conditions, intervenes to prevent damage to the high-voltage propulsion battery. This intervention includes slowing or stopping the flow of charge if necessary.

The BMS also helps regulate the power flow to the high-voltage propulsion battery during operation. If required, it can limit that power as needed.

Effect of Temperature

For optimal battery life and long-term performance, whenever possible, avoid exposing the vehicle to ambient temperatures above 40° C (104° F) or below -20° C (-4° F) for extended periods.



WARNING

Do not expose the vehicle to ambient temperature above 60° C (140° F).

The vehicle cannot be charged at ambient temperature below 2.5 °C (36.5 °F). Charging in extreme temperatures can limit the rate of charge the high-voltage battery receives.

When the battery pack has an internal temperature outside of the appropriate range, the Battery Management System (BMS) intervenes and requires the cooling system to bring the temperature to the appropriate level. Charging will resume once the temperature has returned to an appropriate range.

Driving in extreme temperatures can also affect the overall performance and autonomy of the vehicle.

High-Voltage Battery State of Charge

The vehicle operates best when charged regularly. The high-voltage battery does not need to be fully depleted before charging again. Rather than waiting until the battery charge is low to recharge, take advantage of every opportunity to charge when the vehicle is not in use.

NOTICE

If the high-voltage battery charge is extremely low, it should be plugged in within 24 hours of being discharged to avoid potential damage and preserve its longevity.

State of Charge (SoC) refers to the level, in percentage, at which the HV battery is charged. Ranging from 0% to 100%, the SoC indicates how much energy the HV battery has available.

Using the vehicle with a high voltage battery SoC between 20% and 80% is optimal for its longevity.

High-Voltage Battery State of Health (SoH)

The state of health (SoH) refers to the current health condition of the high voltage (HV) battery compared to its initial state when it was new.

The HV battery life span is directly related to its SoH. When the HV battery ages, it gradually loses performance and range.

To help preserve a good SoH and minimize degradation:

- Avoid frequent hard accelerations or sustained top speeds when riding
- Use your vehicle with a SoC of 80% as much as possible.

Using a level 1 (120V or 240V / 16 amp) or slow charger does take longer but is better for your HV battery. The rate at which the electricity is pushed in the HV battery directly impacts its long-term performance.

Using a level 2 (240V / 30 Amp) is ideal for quick refills during a trip or while travelling. If you have the time to use a level 1 charger, your HV battery will benefit from less stress.

Maximize the above best practices to gain the most from your HV battery. Chemical degradation cannot be stopped but can be maintained to its lowest speed.

Vehicle Recharge

WARNING

Do not use a multi-plug adapter or extension cord.

WARNING

People with medical electric devices, such as a pacemaker or a cardiovascular defibrillator, should consult their physician for recommendations related to electric vehicles and electric vehicle supply equipment (EVSE).

NOTICE

To prevent dirt and debris from potentially damaging terminals, ensure that the charge port cover and charge compartment door are closed and secured when not charging the vehicle. If the terminals build up debris over time, do not use tools to clean the terminals. Use compressed air, a soft cloth or low-pressure water to clean.

To charge the high-voltage propulsion battery:

1. Stop the vehicle on a flat surface.

2. Deploy the side stand.
3. Ensure the stop switch is OFF.
4. Open the hinged charge port cover.

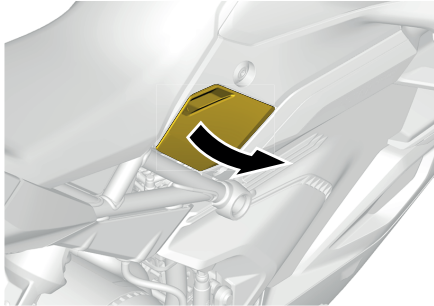

5. Ensure that the charger socket is free of dirt, debris and water.
6. Insert the EVSE charging cable connector into the vehicle charging port.

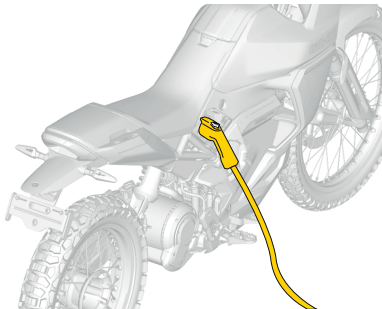

7. Ensure the EVSE charging cable is correctly locked in vehicle charging port.

NOTE

On vehicle with Type 2 charging port (IEC 62196), the charging cable will lock automatically when detected by the vehicle.

8. Select the charging option that corresponds to your need.
 1. Press the charging option button on the charging screen.

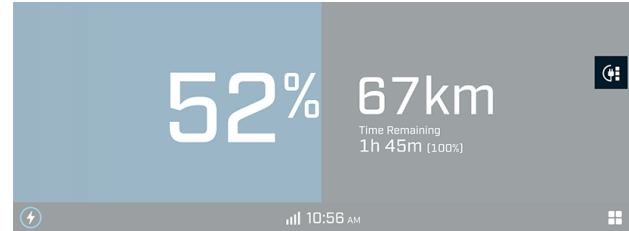

2. Select one from three charging options: 30%, 80% or 100%.

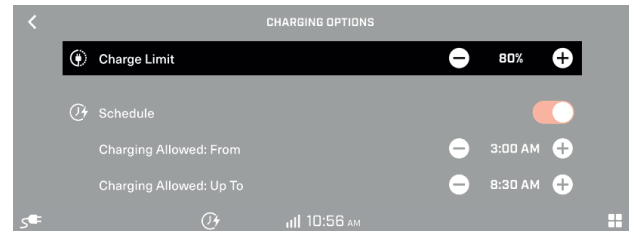

The vehicle display will switch to the charging display. Charging will continue until the battery state of charge reaches the level selected or the EVSE is disconnected.

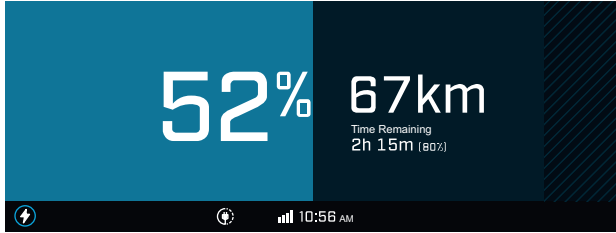

Though charging will continue until completion, based on state of charge level selection, the display will turn off after 30 seconds of inactivity. Touch the screen to resume the display if desired or insert the key to change charge level selection.

When charging is complete, the vehicle will shut down. Turning on the key will activate the multifunction display, the estimated time remaining will show “Completed”.

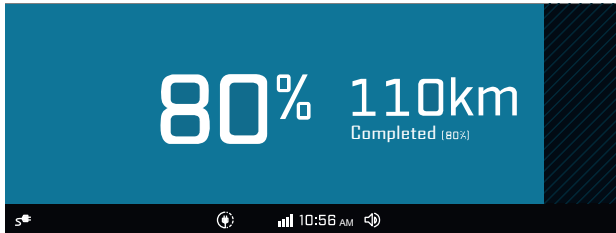

Ideal Times to Charge

It can be helpful to avoid charging during “peak hours” if possible. Peak hours are those times when electricity demand is the highest across the power grid. Typically, charging at night avoids peak hour times. Charging the vehicle at times like this can help keep charging costs low. Check with your electric company for more information.

To schedule the charging time, the schedule charge function in the Energy settings could be used. Refer to [Applet Menu, page 3-38](#) for more information.

Vehicle Charging Cable Removal

To remove the charging cable from the vehicle:

1. Type 1: Hold down the release button on the charging cable for one second and then remove it from the charging port.

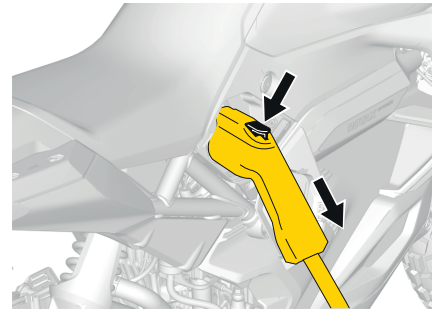

Type 1 Charging Cable Connector (SAE J1772)

2. Type 2: Turn the key to on position, press the UNLOCK button on the multifunction display and then remove the charging cable from the charging port.

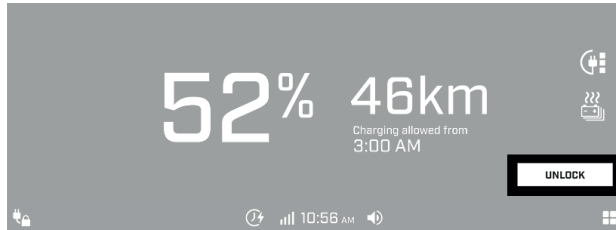

Type 2 Charging Cable Connector (IEC 62196)

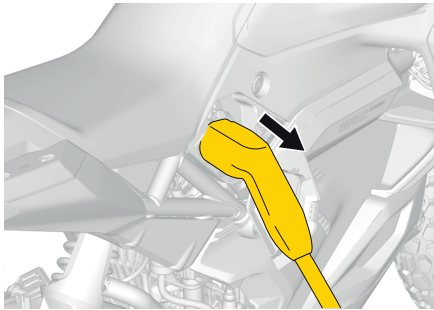

3. Close the charging port cover.

OPERATING THE VEHICLE

Starting the vehicle

To activate the vehicle:

1. Insert the key into the key switch and rotate to the ON position. The display will turn on.
2. Read and acknowledge the warning statement. The acknowledgement is done by turning the accelerator handle away from you.

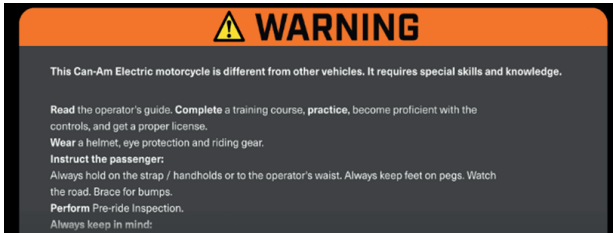

3. Retract the side stand backward.

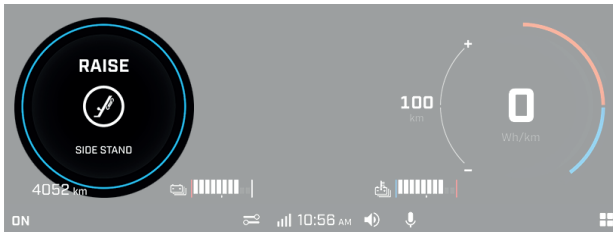

4. Push the stop switch in the ON position.

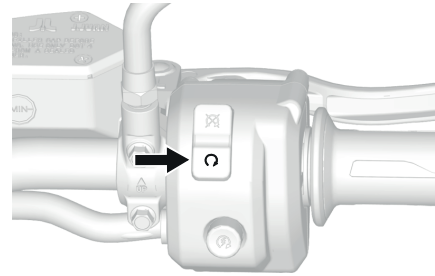

5. Rotate the accelerator handle away from you and hold it there.

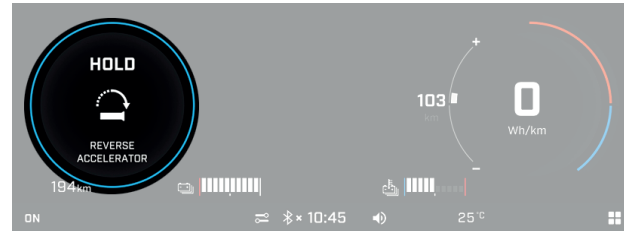

- Press the start button to activate the high-voltage propulsion system.

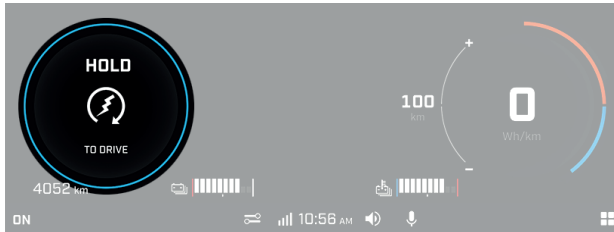

- Let go the accelerator handle back to its neutral position. The vehicle is now READY to move and  indicator appears. By default upon completing the starting sequence, the propulsion drive direction will be forward (D).

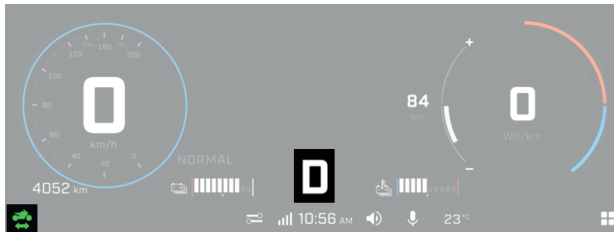

- When ready to move, the accelerator handle can be rotated toward you to accelerate in the forward direction.

WARNING

Avoid unintentional movement of the motorcycle. Accidental twist of the accelerator grip could cause severe injury or death to you or bystanders. Be aware that this vehicle does not have engine noise to indicate when the propulsion system is enabled.

When stopped, depress the brake lever to prevent accidental access to the accelerator grip or disable the READY to move mode. Always look for the READY to move icon in the multifunction display before reaching for the accelerator grip.

3

Ready to Move Mode

The READY to Move  mode is activated once the starting sequence is completed. This mode means the vehicle will move upon twisting the accelerator handle.

You can recognize the vehicle to be in the READY to Move mode when the  icon is visible on the bottom left corner of the multifunction display, and when the selected propulsion drive direction indicator is displayed, either forward (D) or reverse (R) direction.

While the vehicle is at standstill (wheels not moving) in this mode, the left circular gauge is also pulsating in light blue indicating the vehicle is ready to move. Once the vehicle has started to move the blue pulsation will stop and show the vehicle speed, but the  icon and selected propulsion drive direction indicator will remain visible.

Also, while the vehicle is at standstill in this mode, if there is no user interaction with the vehicle for five (5) minutes, a tone will sound, and the vehicle will automatically disable the READY to move mode. The propulsion system will then be disabled. Depressing the brake lever or pedal when stationary will keep the vehicle in READY to move mode. After the READY to move mode has been automatically disabled, it can be enabled with the Starting the Vehicle sequence.

To disable the READY to Move mode and only disable the propulsion system:

1. Push the Stop switch in OFF position. Refer to [Stop Switch Operation, page 3-16](#); or
2. Extend the side stand forward. Refer to [Side Stand operation, page 3-26](#).

When the propulsion system is disabled, the ON icon will appear on the bottom left corner of the multifunction display, and no drive direction icons will be visible.

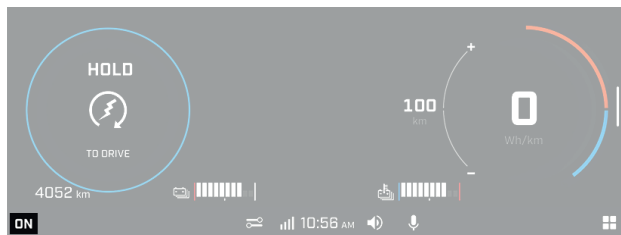

Switching to and from Reverse

When the  icon is visible, the vehicle is set to the forward drive position (D).

To switch to reverse mode, press and hold the Start button. Repeat the procedure to return to forward drive mode.

When the drive direction (R) is visible the accelerator handle can be rotated away from you to move in the backward direction.

Drive Modes

WARNING

Be aware when driving on slippery surfaces that the vehicle systems cannot compensate for all dangerous driving situations.
USE YOUR COMMON SENSE.

For optimal ABS and MTC performance, always select the appropriate drive mode and traction control setting depending on the surface condition.

OFF-ROAD modes

OFF-ROAD modes are specially designed to be used on all deformable surfaces such as gravel, dirt, sand or mud. **Experienced riders** may select and use the OFF ROAD drive modes. These modes are **not** recommended when driving on paved surfaces.

When selected, these vehicle drive modes will return to NORMAL mode after a key cycle.

OFF-ROAD+*

When the OFF-ROAD+ mode is selected, the accelerator response is higher in order to improve performance. ABS is active on front wheel only (with reduced sensitivity) and MTC provides a very permissive slip of the rear wheel during acceleration and can be deactivated. During deceleration or regen usage, the MTC will not monitor and/or control the rear wheel slip.

** The OFF-ROAD+ mode is not available on A1 License model.*

OFF-ROAD

When the OFF-ROAD is selected, acceleration is normal, ABS is active on front wheel (with reduced sensitivity), and deactivated on rear wheel. The MTC will provide a permissive slip of the rear wheel during acceleration, can be deactivated, per user preferences. During deceleration or regen usage, the MTC will not monitor and/or control the rear wheel slip.

SPORT mode*

When the SPORT mode is selected, the accelerator response is higher in order to improve performance.

ABS is active on both wheels and MTC provides a normal slip of the rear wheel and can be deactivated for vehicle acceleration.

When selected, the SPORT mode will remain active after a key cycle, and the MTC will return to on, if deactivated.

** The SPORT mode is not available on A1 License model.*

NORMAL Mode

When the NORMAL mode is selected, accelerator response is normal, ABS is active on both wheels and MTC provides a normal slip of the rear wheel and cannot be deactivated.

When selected, the NORMAL mode will remain active after a key cycle.

RAIN Mode

When the RAIN mode is selected, accelerator response is normal, ABS is active on both wheels and MTC provides a very restrictive of the rear wheel and cannot be deactivated.

When selected, the RAIN mode will remain active after a key cycle.

ECO Mode

When the ECO mode is selected, the accelerator response is lowered in order to improve vehicle range.

ABS is active on both wheels and MTC provides a normal slip of the rear wheel and cannot be deactivated.

When selected, the ECO mode will remain active after a key cycle.

Vehicle Modes Summary

The table below provides a condensed summary of the vehicle drive modes interaction with the vehicle driving aid technologies.

Drive mode	ABS	Accelerator Response	Motorcycle Traction Control (MTC)		Ability to disable MTC
			Acceleration	Deceleration	
OFF ROAD+	Front: Reduced Rear: OFF	High	Very Permissive Slip	Off	Yes
OFF ROAD		Normal	Permissive Slip		
SPORT	ON	High	Normal		Yes
NORMAL		Normal	Very Restrictive Slip		No
RAIN			Normal Slip		
ECO			Low	Normal Slip	

Vehicle Modes Display

The selected vehicle mode is visible on the multifunction display:

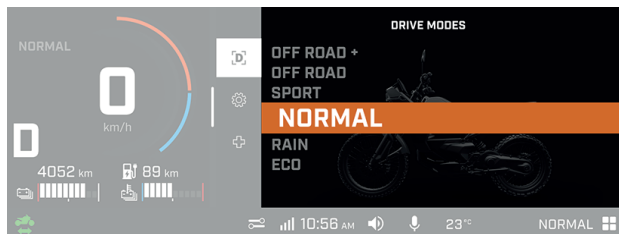

* Some vehicle drive modes may not be available depending your model selection.

NOTICE

When changing drive modes or switching MTC on or off, the accelerator grip must be at the released position.

If a drive mode or MTC mode is selected while the accelerator is not released, the mode change request will be put on hold. In this case, a notification in the multifunction display will be displayed informing that the accelerator must be released. From the moment you have selected the new drive mode or the new MTC mode, you have 5 seconds to release the accelerator, otherwise the change request will time out and the engaged mode will remain unchanged.

MTC can be turned off only when the vehicle is not moving. MTC can be turned on when the vehicle is moving or not.

NOTICE

If the drive mode or MTC mode cannot be switched even if the accelerator is released, a notification will be displayed in the multifunction display informing that the mode change is currently not possible.

If this occurs while moving, try to change the mode again without decelerating or accelerating.

If the vehicle drive modes cannot be changed or the MTC system has malfunction, see an authorized BRP dealer and have the vehicle inspected.

Regen modes

When the conditions allow it, the regenerative braking takes energy from the moving motorcycle through its rear wheel and stores it in the high-voltage battery so it can be used later.

This vehicle offers two independent ways to request regen:

- Passive
- Active

The passive regen controls the deceleration felt when the accelerator handle is released and the active regen, when the accelerator handle is twisted away from you.

Each mode can be set to OFF, MIN and MAX.

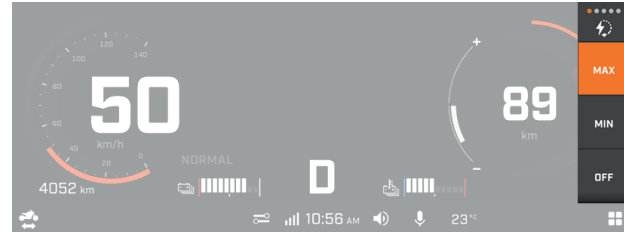

To access the vehicle setting page, press the window icon on the bottom right corner and press on the "Vehicle" title and gear icon.

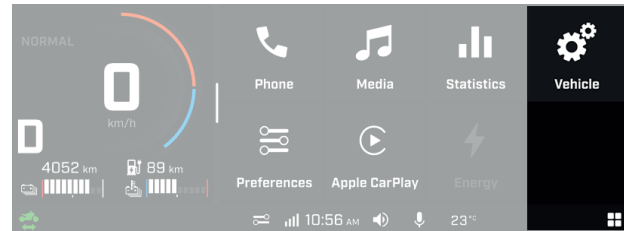

Once in the Vehicle Settings, the operator can select the gear icon and independently modify both Regen modes.

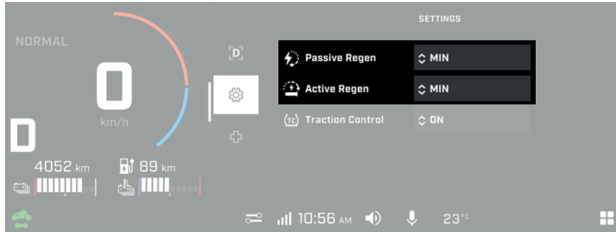

The availability of regenerative braking will vary based on these settings and other parameters such as the state of charge and temperature of the high voltage battery. The Multifunction display will always show the currently available regenerative braking capability as described in the [Multifunction Display, page 3-34](#) section.

The regenerative braking differs from the vehicle brakes on many aspects such as:

- Only works on the rear wheel
- Does not work at very low speeds or at standstill
- Changing availability.

It is therefore not a substitute for the vehicle brakes, which should be used to stop the vehicle.

Turning OFF the Vehicle

To turn off the vehicle:

1. Stop the vehicle in a safe place.

2. Push the stop switch in the OFF position.

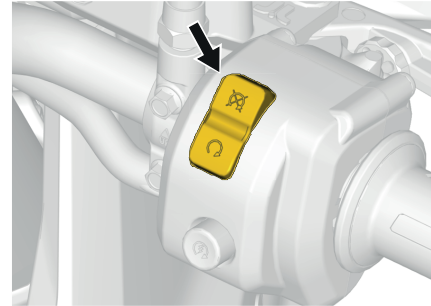

3. Turn the key to the OFF position.
4. Extend the side stand forward.

TUNE YOUR RIDE

Vehicle handling and comfort depend upon multiple adjustments.

Choice of suspension adjustments vary with carrying load, operator's weight, personal preference, riding speed and field conditions.

WARNING

Before proceeding with any suspension adjustment, remember:

- Park in a safe place.
- Use appropriate lifting device as a small scissor lift platform installed underneath the front skid plate, or have assistance to share lifting stress. If a lifting device is not used, use proper lifting techniques, including lifting with your legs.
- Do not attempt to lift the front or rear of vehicle if it is above your limits.
- Secure the front wheel in a wheel chock for motorcycle.
- Support rear of vehicle off the ground with a suitable device before adjusting suspension.
- Make sure the support device is stable and secure.

The best way to set up the suspension is to adjust the vehicle ride height before making any changes to the compression or rebound damping adjustments. It may be necessary to readjust depending on vehicle weight configuration. Test run the motorcycle under the same conditions (speed, road condition, operator riding position, etc). Proceed methodically until you are satisfied.

Following are guidelines to fine-tune the rear suspension.

Suspension Adjustment Guidelines

<i>Problem</i>	<i>Corrective Measures</i>
Rear of motorcycle seems too stiff	<ul style="list-style-type: none"> Validate Sag is within acceptable range, adjust rear suspension spring preload if required
Rear of motorcycle seems too soft	<ul style="list-style-type: none"> Validate Sag is within acceptable range, adjust rear suspension spring preload if required Adjust compression and rebound damping
Rear of motorcycle is frequently bottoming	

The vehicle payload may impact tire pressure and suspension preload adjustment.

The rear suspension stock settings (*) are appropriate for a payload range of 77.1 to 95.2 kg (170 to 210 lbs).

<i>Payload Range</i>		<i>Spring length</i>		<i>Damping adjustment</i>		<i>Front Tire pressure</i>		<i>Rear Tire Pressure</i>	
				<i>Compression firm / recommended / soft</i>	<i>Rebound recommended</i>				
<i>kg</i>	<i>lb</i>	<i>mm</i>	<i>in</i>	<i>(Clicks)</i>	<i>(Clicks)</i>	<i>kPa</i>	<i>PSI</i>	<i>kPa</i>	<i>PSI</i>
Less than 59	Less than 130	269	10.59	18 / 20 / 22	10	138	20	165	24
59 to 77.1	130 to 170	265	10.4	17 / 19 / 21	8	152	22	193	28
77.1 to 95.2*	170 to 210*	260*	10.24*	16 / 18* / 20	6*	165*	24*	207*	30*
95.2 to 113.4	210 to 250	254	10	15 / 17 / 19	6	165	24	207	30
113.4 to 131.5	250 to 290	249	9.80	14 / 15 / 18	5	165	24	207	30
131.5 to 149.7	290 to 330	243	9.57	12 / 13 / 16	4	165	24	207	30

Suspension Adjustment (Preload)

NOTE: The front suspension cannot be adjusted. The rear suspension preload, rebound and compression can be adjusted. The rear suspension preload adjustment requires special tools. Contact an authorized BRP dealer if you are not properly equipped.

IMPORTANT

The location or distribution of the payload will affect the calibration. When adjusting the rear suspension, the SAG must be measured and adjusted first with the spring preload adjustment.

Ensure the vehicle payload is reflecting a day-to-day vehicle usage configuration, including all accessories, rider and passenger weight, before measuring the SAG.

1. Measure the SAG as follows:

Motorcycle Scissor Lift

(Commercially available)



1. Install a motorcycle scissor lift below the motorcycle, under the front skid plate.
2. Secure the motorcycle to the scissor lift using straps.
3. Lift the motorcycle to fully extend the rear suspension.
4. Measure from wheel center to a fixed point on the tail directly above the wheel.

NOTE

Record the value (A).

5. Lower the vehicle.
6. Have the rider sit on the motorcycle with full riding gear, in their normal riding position.
7. Measure from wheel center to the same fixed point on the tail directly above the wheel.

NOTE

Record the value (B).

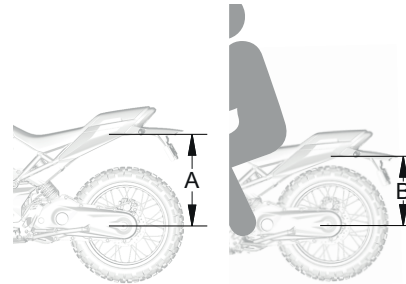

2. Calculate the measured SAG (mSag) value using the following formula:

$$mSag = A - B.$$

NOTICE

The SAG must be within the acceptable range of 76 to 92 mm (3.00 to 3.62 in). This corresponds to a wheel travel of 30 to 35 % from full drop. Adjust the spring preload as required.

3. Remove the rear suspension from the motorcycle as follows:
 1. Lift the motorcycle to obtain clearance, ensure the rear wheel is in contact with the ground.
 2. Remove the quarter turn cap from the LH side body panel to gain access to the rear suspension upper bolt.

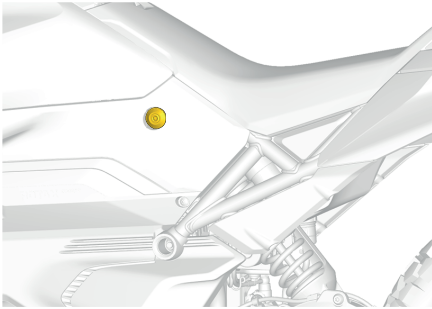

3. Remove upper suspension bolt.

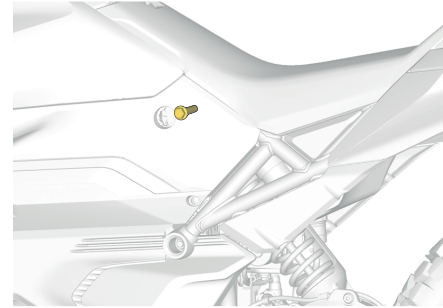

4. Remove the lower rear suspension bolt.

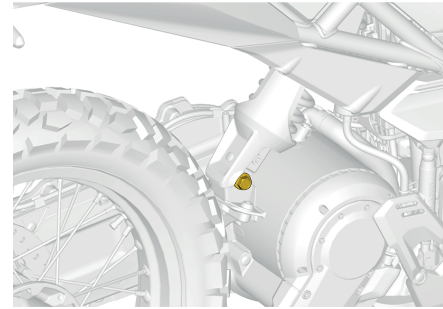

5. Remove rear suspension from the motorcycle.
6. Clean and inspect the rear suspension.
4. Adjust the spring preload as follows:

Adj. Spanner Wrench

(Commercially available)



1. Measure and note the spring preload length.

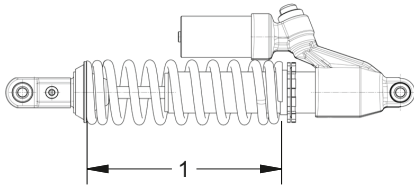

1. Spring preload length

 NOTE

The spring length should be adjusted to obtain the optimal SAG of 84 mm (3.30 in) or 33% of from full drop.

2. Calculate the **Delta spring preload** using the following formula and, refer to [Suspension Adjustment Guidelines, page 3-66](#) for rear suspension adjustment recommendations.

$$1/2 \times (tSag - mSag) = \text{Delta spring preload}$$

Where:

- $1/2$ is the motion ratio
- **tSag** is the optimal SAG (84 mm (3.30 in))
- **mSag** is the measured SAG (motorcycle payload).
- **Delta spring preload** is the spring preload length required adjustment.

Example:

A measured Sag of 114.75 mm (4.52 in) will result in a negative (-) Delta spring preload, meaning the spring preload length should be adjusted / reduced by 14.8 mm (0.58 in).

3. Unscrew the preload lock nut using a spanner wrench.
4. Rotate the preload nut using a spanner wrench to adjust the spring preload length per **Delta spring preload** value.

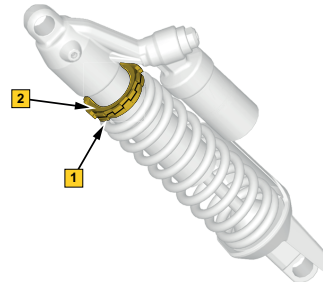

1. Preload nut
2. Preload lock nut

5. Tighten the preload lock nut (2) to secure the lower preload adjustment nut.

Tightening Torque	
Preload lock nut	27.5 ± 2.5 Nm (20.28 ± 1.84 lbf-ft)

6. Install rear suspension on the motorcycle.
7. Install upper and lower rear suspension bolts.

Tightening Torque	
Rear suspension upper bolt	61 ± 9 Nm (45 ± 6.64 lbf-ft)
Rear suspension lower bolt	61 ± 9 Nm (45 ± 6.64 lbf-ft)

8. Validate the mSag is within acceptable range with the vehicle payload.
9. Install quarter turn on the LH side body panel.
5. Adjust the rear suspension compression and rebound damping. Refer to [Damping Adjustment, page 3-70](#).

Damping Adjustment

Damping adjustment can be easily made to fine tune the rear suspension. Before making damping adjustment, ensure the rear suspension SAG is appropriate. Refer to [Suspension Adjustment \(Preload\), page 3-67](#).

NOTE:

The compression damping controls how the shock absorber reacts to compression strokes.

The rebound damping controls how the shock absorber restrains the extension stroke.

In repetitive short small bumps (ripple), it is recommended to use a lower rebound damping setting.

1. Remove the driver seat to access the compression adjustment screw. Refer to [Driver Seat Removal, page 3-19](#)

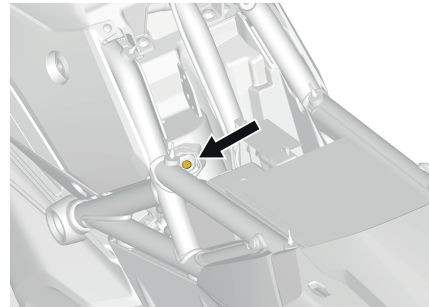

compression adjustment screw location

2. Adjust the rear suspension compression and rebound damping, as follows:

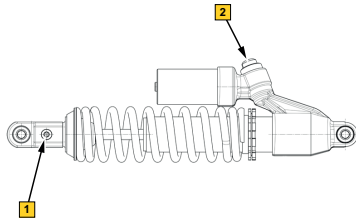

1. Rebound adjustment screw

2. Compression adjustment screw

1. Rotate the compression adjustment screw (1) and/or damping adjustment screw (2) to the maximum **clockwise** position.
2. Rotate the adjustment screws (1) or (2) **counter-clockwise** to obtain the desired set up (clicks).
The compression and rebound damping should be adjusted according to the spring length. Refer to [Suspension Adjustment Guidelines, page 3-66](#)
3. Reinstall the driver seat. Refer to [Driver Seat Installation, page 3-20](#).
4. Ride the motorcycle to validate proper damping adjustment, readjust as required to fine tune the rear suspension.

4 MAINTENANCE - TABLE OF CONTENTS

PERIODIC MAINTENANCE	4-2
Maintenance Schedule	4-4
MAINTENANCE PROCEDURES	4-8
Brakes	4-8
Chassis	4-11
Cooling System	4-12
Drive System	4-13
Low Voltage Electrical System	4-18
High-Voltage Electrical System	4-25
Vehicle Controls and Operation	4-25
STORAGE AND PRESEASON PREPARATION	4-26
Storage	4-26
Preseason Preparation	4-27
MAINTENANCE RECORDS	4-28
VEHICLE CARE	4-36
Vehicle Care General	4-36
Vehicle Cleaning	4-36
Vehicle Protection	4-37

PERIODIC MAINTENANCE

Periodic Maintenance General

Maintenance is very important to keep your vehicle in a safe operating condition. The vehicle should be serviced as per the maintenance schedule.

Proper maintenance is the owner's responsibility. A warranty claim may be denied if, among other things, the owner or operator caused the problem through improper maintenance or use.

Perform periodic checks and follow the maintenance schedule. **The maintenance schedule does not exempt the pre-ride inspection.**

 **WARNING**

Failure to properly maintain the vehicle according to the maintenance schedule and procedures can make it unsafe to operate.

Break-In Inspection

We recommend that after the first 5 000 km (3,000 mi) of operation, your motorcycle be inspected by an authorized Can-Am dealer, repair shop, or person of your own choosing. This maintenance is very important and must not be neglected.

NOTE: This inspection is at the expense of the vehicle owner.

We recommend that this inspection be signed by the authorized Can-Am On-Road dealer, repair shop, or person of your own choosing having performed the first inspection.

Date of inspection

Signature of the Authorized Can-Am On-Road dealer, repair shop, or person

Name of the Authorized Can-Am On-Road dealer, repair shop, or person

Periodic Maintenance

After the completion of the *Break-In Inspection*, make sure to perform proper maintenance at recommended intervals as indicated in the tables.

The maintenance chart indicates items needing to be addressed based on 2 criteria, whichever happens first:

- Calendar time
- Odometer reading

Whether your motorcycle is a dual-sport or street model, it requires yearly maintenance. These items are identified as A in the chart below.

If you regularly ride in **trails or explore the countryside** with your electric motorcycle, follow the A* Dual-Sport Interval and perform the tasks outlined in the chart below at half the indicated interval.

Your driving habits determine the factors you should adhere to. For example:

- Someone who uses their vehicle every other weekend trail riding with friends would most likely follow the **odometer reading** to determine the frequency of his maintenance.
- Someone who uses their vehicle seldomly over the year or only on a few occasions would follow the **calendar time** to determine the frequency of his maintenance.

NOTICE
The following tables show the appropriate maintenance application for the first 3 years. For subsequent years, repeat the same pattern alternatively.

Maintenance Overview		
Calendar Time	Odometer	Dual-Sport Interval
—	5000 km (3,000 mi)	Break-In
Every 6 Months	10000 km (6,200 mi)	A*
1 Year	15000 km (9,300 mi)	A
Every 6 Months	20000 km (12,400 mi)	A*
2 Years	25000 km (15,500 mi)	A
Every 6 Months	30000 km (18,600 mi)	A*
3 Years	35000 km (21,800 mi)	A

Maintenance Schedule

Origin Series

NOTE:

*: Inspection points applicable if the vehicle is used for more than 50% for off-road riding or more.

<i>Dual-Sport Interval</i>	<i>Break-In</i>	<i>A*</i>	<i>A</i>
<i>A = Adjust</i> <i>C = Clean</i> <i>I = Inspect</i> <i>L = Lubricate</i> <i>R = Replace</i> <i>T = Torque</i>	<i>5000 km</i> <i>(3,000 mi)</i>	<i>Every 6 month</i> <i>or</i> <i>5000 km</i> <i>(3,000 mi)</i>	<i>Every year</i> <i>or</i> <i>10000 km</i> <i>(6,200 mi)</i>
Body and Chassis			
Body panels and hardware	I, T		I, T
Skid plate condition	C, I		
Pivots, latches, hinges and key barrels	C, L		C, L
Sidestand	L, T		
Cooling			
Cooling components (coolant level, hose condition, clamps, leaks)	I, A		
Radiator	C		
Coolant ¹	R Every 5 years		
Brake			

Dual-Sport Interval	Break-In	A*	A
A = Adjust C = Clean I = Inspect L = Lubricate R = Replace T = Torque	5000 km (3,000 mi)	Every 6 month or 5000 km (3,000 mi)	Every year or 10000 km (6,200 mi)
Brake components and function	I, L		I, L
Brake fluid	R <i>Every 2 years</i>		
Controls			
Accelerator operation	I		
Drive			
Drive components and function 1	I		
Drive system fill cap / vent		R <i>First time at 25000 km (15,500 mi),</i> <i>Then every 20000 km (12,400 mi)</i>	
Drive system chain 1		I <i>First time at 25000 km (15,500 mi),</i> <i>Then every 20000 km (12,400 mi)</i>	
Drive system oil	R		R
Front wheel axle nut	T		
Tires	I, A		
Wheel bearings	I		

Dual-Sport Interval	Break-In	A*	A
A = Adjust C = Clean I = Inspect L = Lubricate R = Replace T = Torque	5000 km (3,000 mi)	Every 6 month or 5000 km (3,000 mi)	Every year or 10000 km (6,200 mi)
Wheel lug nuts (rear)		T	
Wheel spokes		I	
Low-Voltage Electrical			
12V battery connections and condition	I		I
Low voltage electrical harness routing	I		I
Operation of control switches and lighting	I		I
Modules and applicable software updates ¹	I		I
High-Voltage Electrical			
Charging Port ¹	C, I		C, I
High voltage cables ¹	I		I
High voltage components cooling ¹	I		I
Ground straps ¹	I		I
Steering			
Handlebar clamp	T		T
Steering components and function ¹		I, T	

Dual-Sport Interval	Break-In	A*	A
A = Adjust C = Clean I = Inspect L = Lubricate R = Replace T = Torque	5000 km (3,000 mi)	Every 6 month or 5000 km (3,000 mi)	Every year or 10000 km (6,200 mi)
Suspension			
Suspension components and function	C, I <i>Every ride or tire pressure check interval</i>		
Fork oil and seals ¹		R <i>Every 2 years or first time at 25000 km (15,500 mi), then every 20000 km (12,400 mi) for dual-sport usage</i>	
		R <i>Every 4 years or first time at 45000 km (28,000 mi), then every 40000 km (25,000 mi) for road usage</i>	

¹ *Maintenance tasks require special tools and/or should be performed at an authorized BRP dealer for user safety.*

MAINTENANCE PROCEDURES

This section includes instructions for basic maintenance procedures.

Due to the complexity of some maintenance procedures, good mechanical skills are required.

Several procedures must be done by an authorized Can-Am On-road dealer, repair shop, or person of your own choosing.

If you are not comfortable with the mechanics, do not hesitate to contact an authorized Can-Am On-road dealer, repair shop, or person of your own choosing.

DANGER

Risk of **SERIOUS INJURY** or **DEATH** from **ELECTRIC SHOCK**, **ARC FLASH** or **FIRE**.

The vehicle's high-voltage propulsion system is a self contained system.

- Do not tamper with the high-voltage components in any way.
- The user safety is ensured as long as the high-voltage components are not manipulated and/or modified while the vehicle is activated.
- BRP strongly recommends tasks involving the high-voltage propulsion system to be performed by an authorized BRP dealer.

WARNING

Avoid electric shock that could lead to severe injury or death when performing inspections, maintenance works, or adjustment procedures.

- Procedures not described in the following sections require special tools and thorough knowledge of the technology involved.
- Do not perform tasks that deviates from those contained in this operator's guide.
- Always perform inspections, maintenance and/or adjustment tasks described in the following sections with the vehicle charging cable disconnected, the stop switch in the OFF position and the vehicle key removed, unless otherwise stated.
- Usage of personal protective equipment (PPE), such as safety glasses and shoes, is recommended.

Brakes

WARNING

New brakes will not operate at their maximum efficiency until their break-in is completed. Braking performance may be reduced, so use extra caution. Brakes take about 300 km (200 mi) of riding with frequent braking to break-in. For riding with infrequent braking, allow extra time to break-in the brakes.

Brake Fluid Level Verification

Check the brake fluid level as follows:

1. Park the vehicle on a firm, level surface.
2. Remove the rear lower side fairing. Refer to [Rear Lower Side Fairing Removal, page 3-23](#).
3. Position the steering in the straight-ahead position to ensure reservoir is leveled
4. Verify the brake fluid level in the front reservoir. The fluid level must be above the MIN mark.

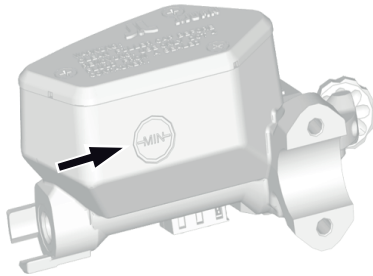

5. Verify the brake fluid level in the rear reservoir. The fluid level must be between the UPPER and LOWER mark.

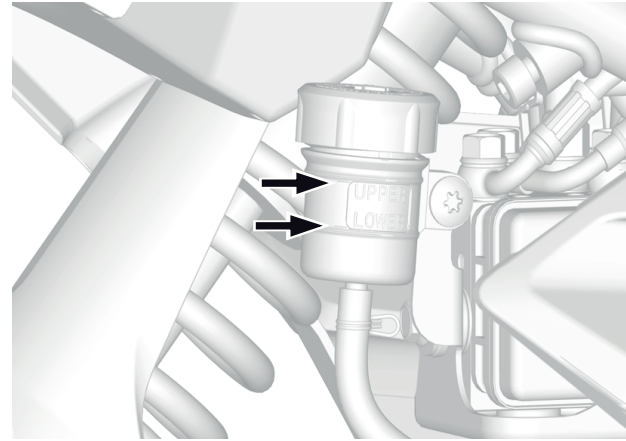

6. Add brake fluid as required. Refer to [Brake Fluid Refill, page 4-10](#).

NOTICE

Low brake fluid may indicate leaks or worn brake pads. See an authorized BRP dealer.

Brake Fluid Refill

NOTICE

Brake fluid can damage painted surfaces or plastic parts. Wipe up any spills using mild soap diluted in clean water or Isopropyl Alcohol.

NOTICE

Use only DOT 4 brake fluid from a sealed container.

1. Refill the front brake fluid reservoir as follows:
 1. Remove the front brake fluid reservoir cover.

⚠ WARNING

Clean the filler cap and its surrounding area before removing it in order to avoid brake fluid system contamination.

2. Remove the reservoir diaphragm.
3. Refill the front brake reservoir with **NEW** brake fluid. The fluid level must be above the MIN mark.

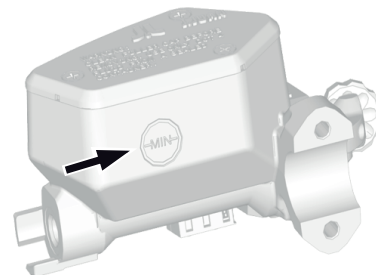

4. Reinstall the reservoir diaphragm and cover.
2. Refill the rear brake fluid reservoir as follows:
 1. Remove the rear lower side fairing, (if equipped). Refer to [Rear Lower Side Fairing Removal, page 3-23](#).
 2. Remove the reservoir cover.

⚠ WARNING

Clean the filler cap and its surrounding area before removing it in order to avoid brake fluid system contamination.

3. Remove the reservoir diaphragm
4. Refill the front brake reservoir with **NEW** brake fluid. The fluid level must be between the UPPER and LOWER mark.

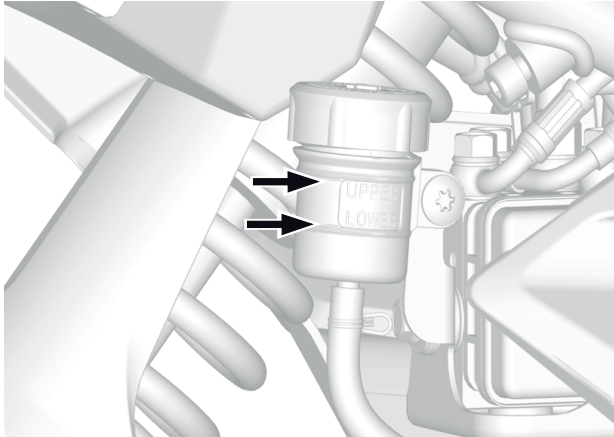

5. Reinstall the reservoir diaphragm and cover.
6. Reinstall the rear lower side fairing (if equipped). Refer to [Rear Lower Side Fairing Installation](#), page 3-24.

Brake System Inspection

The front and rear brakes are hydraulic disc types. These brakes are self-adjusting and do not require adjustment.

The front or rear brake master cylinder also requires no adjustment.

To keep brakes in good condition, perform the following tasks as per the [Maintenance Schedule](#), page 4-4:

- Check brake calipers for cracks or piston seizure
- Check brake discs thickness or warpage
- Check brake fluid level
- Check brake lines for leaks or signs of wear
- Check brake master cylinder for leaks
- Check brake pads thickness

See an authorized BRP dealer for completion of the brake system inspection.

Chassis

Chassis System Maintenance and Servicing

To keep the chassis system in good condition, the following tasks must be done as per the [Maintenance Schedule](#), page 4-4:

- Clean and lubricate pivots, latches, hinges and key barrels;
- Inspect and torque body panel fixations;
- Lubricate and torque side stand;
- Remove skid plates to remove debris;
- Inspect and clean skid plates.

See an authorized BRP dealer for completion of the chassis system maintenance and servicing.

Steering System Maintenance and Servicing

To keep steering system in good condition, the following tasks must be done as per the [Maintenance Schedule, page 4-4](#):

- Inspect steering head bearing for play or notchiness (adjust pre-load or replace bearings if necessary);
- Torque handlebar fasteners;

See an authorized BRP dealer for completion of the steering system maintenance and servicing.

Suspension Maintenance and Servicing

To keep the suspension in good condition, the following tasks must be done as per the [Maintenance Schedule, page 4-4](#):

- Inspect swing arm bearings;
- Inspect fork dust boots and seals;
- Inspect shock absorbers for leaks or other damages;
- Replace fork oil and seals.

See an authorized BRP dealer for completion of the suspension maintenance and servicing.

Cooling System

Coolant Level Verification

1. Place the motorcycle straight to check the level.

2. Check coolant level at room temperature. Liquid should be at cold level line of coolant tank.

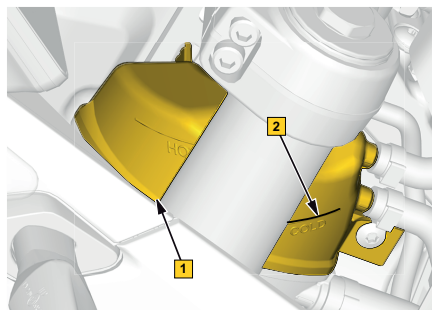

1. Coolant tank.
2. Cold level line.

3. Add coolant if required. Refer to [Coolant Refill, page 4-13](#).

NOTE

When checking level at low temperature it may be slightly lower than the mark.

Coolant Specification

RECOMMENDED COOLANT
XPS Extended life pre-mixed coolant
IF THE RECOMMENDED XPS COOLANT IS NOT AVAILABLE
Use a low silicate, extended life ethylene-glycol premixed coolant (50%-50%)

NOTICE
Always use ethylene-glycol premixed antifreeze containing corrosion inhibitors.

Coolant Refill

NOTICE
Always use ethylene-glycol premixed antifreeze containing corrosion inhibitors.

1. Remove the coolant tank cap.

2. Fill the coolant tank until the coolant level reaches the cold level line.

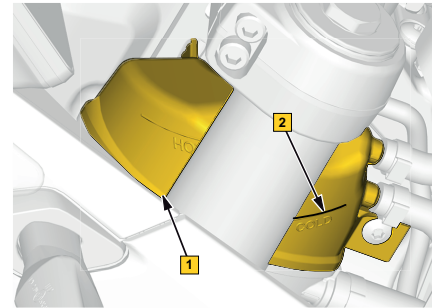

1. Coolant tank.
2. Cold level line.

3. Install the coolant tank cap.

Drive System

Drive System Maintenance and Servicing

To keep the drive system in good condition, the following tasks must be done as per the [Maintenance Schedule, page 4-4](#):

- Inspect drive system oil level and check for contamination;
- Inspect vent area, make sure it is free of dirt and breathing ports are not clogged;
- Replace drive system oil. Refer to [Drive System Oil Replacement, page 4-14](#).

For safety reasons, BRP strongly recommends maintenance tasks involving the drive system to be performed by an authorized BRP dealer. Completion of all maintenance and servicing tasks requires special tools and thorough knowledge of this vehicle drive system.

Drive System Oil Replacement

1. Place the vehicle on a level surface.
2. Place a drain pan under both chaincase plugs area.
3. Remove the fill plug.

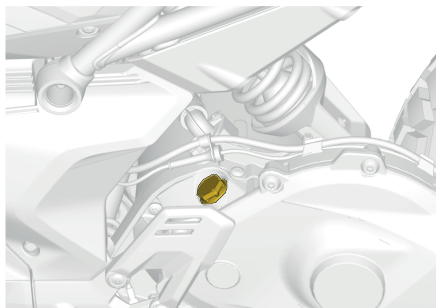

4. Remove the drain plugs located at the bottom of the chaincase and remove metal particles from drain plugs.

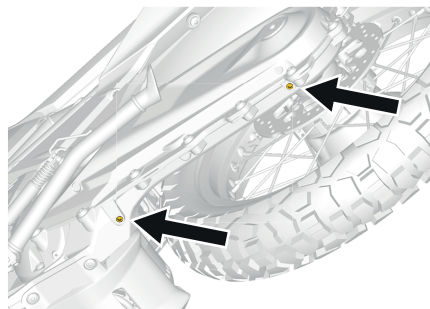

5. Allow used oil to drain out of the chaincase.
6. Apply 592 thread sealant to drain plug threads. Install drain plugs and tighten to specification.

<i>Tightening Torque</i>	
Chaincase Oil drain plug	$6 \pm 1 \text{ Nm}$ ($53 \pm 9 \text{ lbf-in}$)

7. Remove level plug.

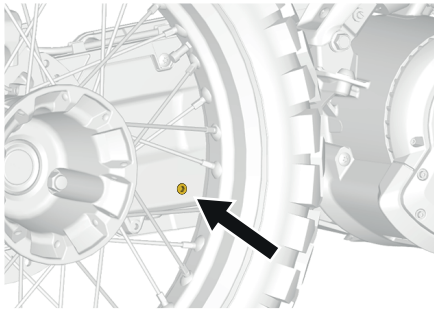

8. Fill the chaincase with **new** oil until the oil is dripping from reference level hole.

Refer to the [Technical Specifications, page 6-2](#) for oil type and quantity.

9. Re-install the level plug.

10. Install the fill plug, tighten to specification.

Tightening Torque	
Fill plug	5 ± 1 Nm (44.25 ± 8.85 lbf-in)

Wheels and Tires

WARNING

Tires that are not the recommended type, damaged, worn down below the minimum tread wear limit indicator or not properly inflated can cause loss of control.

New tires will not operate at their maximum efficiency until their break-in is completed. Braking, steering and MTC performance may be reduced, so use extra caution. Tires take about 300 km (200 mi) of riding with frequent braking and progressive leaning turns to break-in. For riding with infrequent braking and no progressive leaning turns, allow extra time to break-in the tires.

The tires have been specifically designed for this vehicle. Use only the BRP recommended tires for your vehicle, which can be ordered only from an authorized Can-Am On-Road dealer.

Wheels Maintenance and Servicing

1. Check the tire pressure. Refer to [Tire Pressure, page 4-16](#).
2. Inspect tires for wear. Refer to [Tire Tread Wear, page 4-17](#).
3. Inspect wheel spokes for damages and check wheel spoke tension.
4. Inspect rim for damages, cracks and missing balancing weights.
5. Inspect front and rear wheel bearings condition.

6. Torque front wheel axle and pinch bolts.

Tightening Torque	
Front wheel axle	36 ± 4 Nm (26.5 ± 3 lbf-ft)
Pinch bolts	22.5 ± 2.5 Nm (16.5 ± 1.88 lbf-ft)

7. Torque rear wheel lug nuts.

Tightening Torque	
Rear wheel nuts	80 ± 5 Nm (59 ± 3.69 lbf-ft)

See an authorized BRP dealer if the wheels need to be replaced.

When a tire is removed or replaced, perform the following:

- Replace the inner tube
- Inspect brake caliper, disc and pads.
- Air leaks (hissing sound) caused by an ill-fitting rim or a faulty tire valve.

When the front wheel is removed or replaced, perform the following:

- Check and clean the front wheel axle
- Inspect brake caliper, disc and pads.

When the rear wheel is removed or replaced, perform the following:

- Check and clean the rear axle flanges.
- Inspect brake caliper, disc and pads.

Tire Damage

Check all tires for:

- Cuts, slits and cracks in the tires.
- Bumps or bulges in the side of the tire or the tread.
- Nails or other foreign objects in the side of the tire or tread.

If any of the above occurs, have the tire replaced as soon as possible by an authorized Can-Am On-Road dealer.

Tire Pressure

Use the recommended cold inflation pressure for optimum tire performance and wear. Under-inflation or over-inflation may cause uneven tread wear patterns and affect vehicle handling.

Recommended tire inflation pressure is found on the Tires Information Label located on the left side of the front fork.

When temperature changes occur, tire inflation pressures also change. A drop of 6 °C (43 °F) can cause a corresponding drop of 7 kPa (1 lbf/in²) in inflation pressure. Check your tire pressures frequently and adjust them to the proper pressure.

Tire Tread Wear

Check minimum tread depth by using the tread-wear indicators on the center of the tire (hard rubber bars molded at the base of the tread; 1 in figure below).

The tread-wear indicators will appear even with the treads that have been worn down to the minimum tread depth. When at least one tread-wear indicator is even with adjacent threads, have the tire replaced as soon as possible by an authorized BRP dealer.

⚠ WARNING

It is not recommended to use the vehicle on a wet road or trail if the tread-wear indicators are reached or near to be reached. Have the tire replaced for your safety.

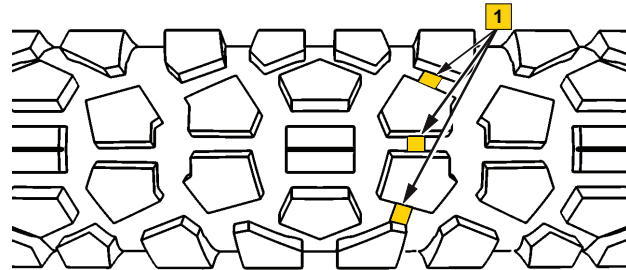

TIRE TREAD WEAR

1. Tread-wear limit indicator

It is normal to see uneven wear on tires depending on how the vehicle is driven and road conditions. The tire's external or internal treads will wear unevenly depending on if the vehicle is driven smoothly or aggressively.

Tire Registration Form

In the event of a tire recall, we can only contact you if we have your name and address. As a vehicle manufacturer, BRP keeps a record of the Tire Identification Number (TIN) associated with the Vehicle Identification Number (VIN) (see *Vehicle Identification*) and its current owner information.

If you replace any tire on your vehicle, a "Tire Registration Form" must be completed and sent to the tire manufacturer consumer service group. The "Tire Registration Form" is available at an authorized Can-Am On-Road dealer.

Low Voltage Electrical System

12V Battery

12V Battery Location

The low-voltage battery is located under the driver seat.

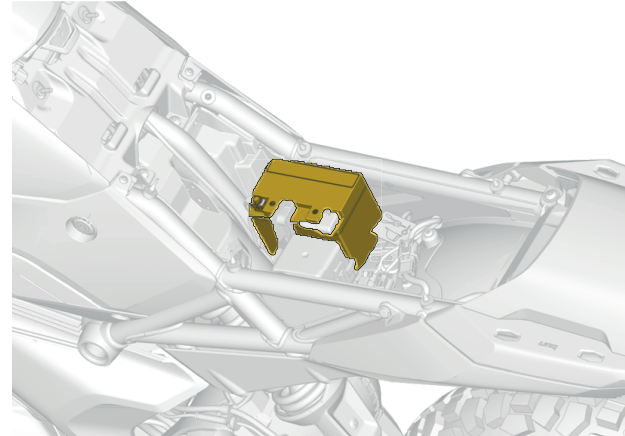

The low-voltage battery has two main purposes:

- Turning on the motorcycle
- Supplying the high current demands of the ABS system during an ABS intervention

12V Battery Removal

1. Open the glove compartment.
2. Remove the driver seat. Refer to [Driver Seat Removal, page 3-19](#).
3. Disconnect the negative terminal first.

NOTICE

Battery negative terminal must always be disconnected first and connected last.

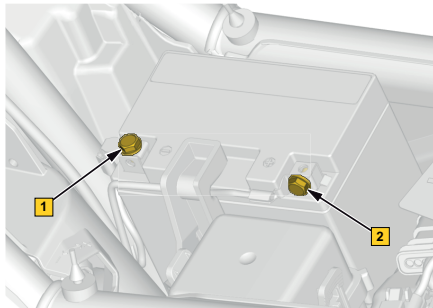

1. *Negative terminal*
2. *Positive terminal*

4. Remove the positive terminal cap.

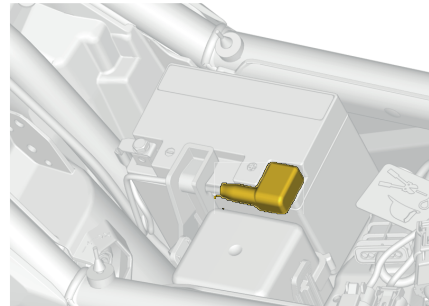

5. Disconnect the positive terminal.
6. Remove the battery bracket screw.

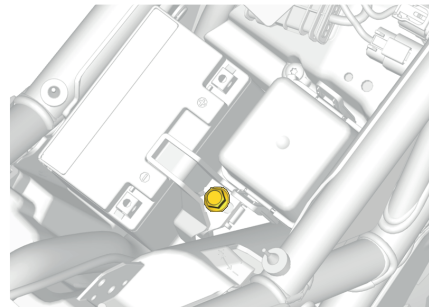

7. Remove the battery and bracket from the vehicle.

12V Battery Recharge

12V battery is recharged via the Dc-Dc converter whenever the HV battery contactors are closed.

The vehicle is equipped with a maintenance-free type battery and is completely sealed; there is no need to add water to adjust the electrolyte level. The battery may need to be charged if the vehicle has not been ridden for at least one month.

WARNING

Do not use conventional lead-acid type batteries. Acid may leak out through the battery vent of a conventional lead-acid type battery. Acid may also leak if the battery case is cracked or damaged, which can cause severe burns.

If the low voltage battery is too depleted to allow vehicle activation, it can be jump started with a car battery. Refer to [Road Side Repairs, page 7-2](#).

The 12V battery should be removed from the vehicle for recharge. A standard battery charger can be used.

For home charging, a “trickle” charger can be used to slow charge the battery. This type of charger can be left connected for a long period of time without damaging the battery. Always follow the charging time as recommended in the charger instructions.

NOTICE

Follow the instructions provided with your battery charger. Improper charging may damage the battery.

To charge the battery, proceed as follows:

1. Remove the battery. Refer to [12V Battery Removal, page 4-19](#).
2. Connect the positive terminal first, then connect the negative terminal.

NOTICE

Battery negative terminal must always be disconnected first and connected last.

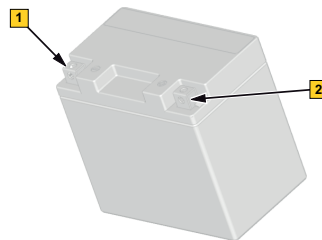

1. *Negative terminal*

2. *Positive terminal*

3. Start the battery charger. Charging time will depend on the charging rate.

When the battery is charged:

4. Disconnect the negative terminal first, then disconnect the positive terminal.
5. Install the battery. Refer to [12V Battery Installation, page 4-21](#).

If the low voltage battery charge cannot be restored, contact an authorized BRP dealer for a replacement battery.

12V Battery Installation

1. Place the battery and bracket in the vehicle.
2. Install the battery bracket screw.

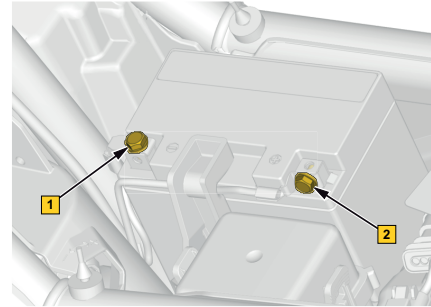
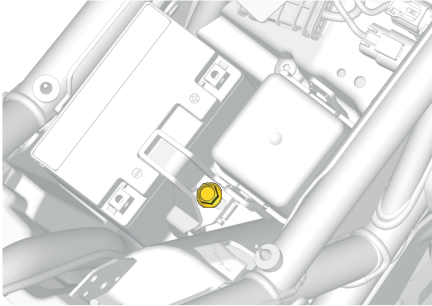

1. Negative terminal
2. Positive terminal

4. Install the positive terminal cap.

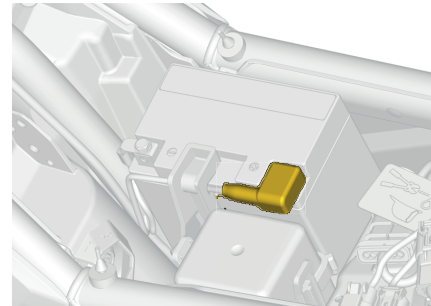

5. Install the driver seat. Refer to [Driver Seat Installation, page 3-20](#).
6. Close the glove compartment.

TIGHTENING TORQUE

Battery bracket screw	4.5 ± 0.5 Nm (39.83 ± 4.43 lbf-in)
-----------------------	---------------------------------------

3. Connect the positive terminal first, then the negative terminal.

NOTICE

Battery negative terminal must always be disconnected first and connected last.

Fuses and Fuse Box

Fuses Box Location

The fuse box is located under the driver seat.

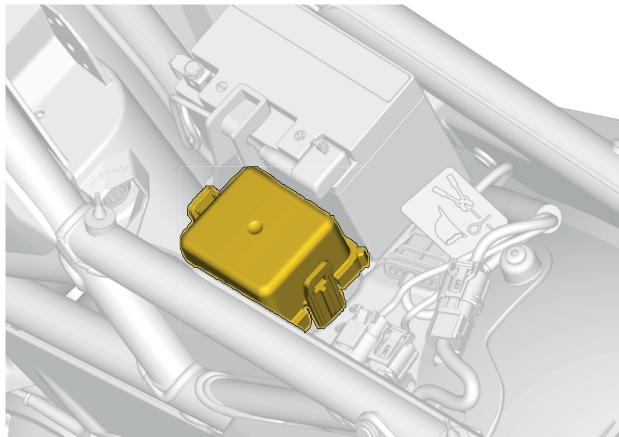

Fuses Inspection

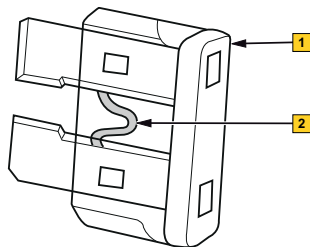

1. Fuse
2. Fuse element

1. Remove the driver seat to access the fuse box. Refer to [Driver Seat Removal, page 3-19](#).
2. Remove the fuse box cover.
3. Remove the fuse from the fuse box.
4. Check if the fuse element is melted. If a replacement is needed, refer to [Fuse Replacement, page 4-23](#).

WARNING

If a fuse has burnt out, the source of the malfunction should be determined and corrected before restarting. See an authorized BRP dealer for servicing.

Fuses Replacement

1. Remove the driver seat. Refer to [Driver Seat Removal, page 3-19](#).
2. Remove the fuse box cover.
3. Remove the defective fuse from the fuse box receptacle.
4. Install a new fuse in the same receptacle. Refer to [Technical Specification, page 6-2](#).



WARNING

Do not use a higher rated fuse.

Lights

Lights Inspection

To keep lighting system in good condition, do the following tasks as per the [Maintenance Schedule, page 4-4](#):

1. Activate the turn signals and verify if each turn signal are lit when activated.
2. Activate the headlight high and low beam. Ensure both headlights are lit when activated.
3. Verify the headlight aim. Refer to [Headlights Aiming Verification, page 4-23](#).

4. Activate the brake lights, with the brake lever and the brake pedal. Ensure the brake lights are lit when activated with the brake lever and the brake pedal.

See an authorized BRP dealer for completion of the lights inspection.

Headlights

Headlights Aiming Verification

NOTICE

Headlights aiming verification must be made without weight on the vehicle.

1. Verify tires are correctly inflated. Refer to the *Tires Information Label* located on the front fork.

- Position vehicle in front of a test surface as shown. Make sure vehicle is on leveled ground.

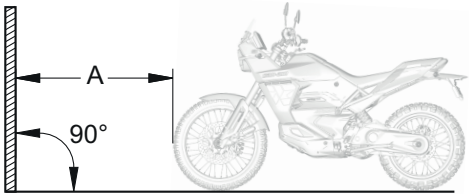

1. 10 m (33 ft)

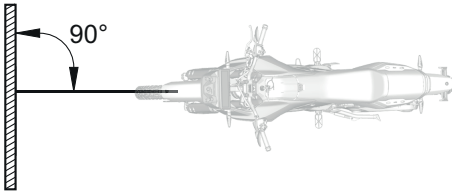

Trace 2 lines parallel to the ground on the test surface as follows:

<i>Lines on the Test Surface</i>	
Line A	For Canada/US: 1256 mm (49-1/2 in) above ground For Europe/other: 1166 mm (45-7/8 in) above ground
Line B	For Canada/US: 1216 mm (47-7/8 in) above ground For Europe/other: 966 mm (38-1/64 in) above ground

- Select **low** beam.
- Beam aiming is correct when the top line of the headlight reflection is between lines A and B.

Headlights Horizontal Aiming Adjustment

The horizontal orientation is fixed and cannot be adjusted.

Headlights Vertical Aiming Adjustment

When adjusting the headlight, low and high beam are adjusted simultaneously.

1. To adjust the headlight rotate the adjuster screw located in the lower right part of the display.

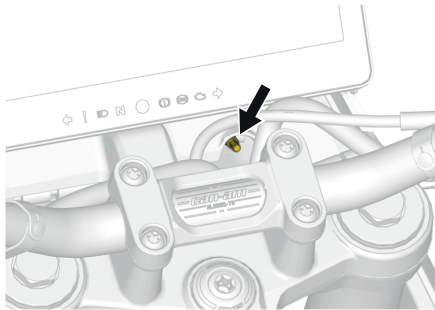

Headlight Beam Adjustment	
Raise beam	Turn adjuster screw counterclockwise
Lower beam	Turn adjuster screw clockwise

High-Voltage Electrical System

High-Voltage Electrical System Maintenance and Servicing

To keep high-voltage electrical system in good condition, do the following tasks as per the *Maintenance Schedule*:

1. Inspect charging port for signs of corrosion and clean drain path
2. Inspect ground straps integrity

3. Visually inspect high-voltage cable routing for signs of chaffing, rubbing or discoloration

4. Inspect high-voltage components for signs of coolant leaks

See an authorized BRP dealer for completion of the high-voltage electrical system maintenance and servicing.

Vehicle Controls and Operation

Vehicle Controls and Operation Maintenance and Servicing

1. Inspect horn operation
2. Check accelerator handle operation. Activate the accelerator in both direction to ensure it operates freely. It must return to closed position when released
3. Inspect proper function of the sidestand and the sidestand switch
4. Inspect proper function of the start switch
5. Inspect proper function of the stop switch

See an authorized BRP dealer for completion of vehicle controls and operation maintenance and servicing.

STORAGE AND PRESEASON PREPARATION

Storage

Proper storage is necessary when the motorcycle is not in use for more than three months.

When planning on storing the vehicle for more than 90 days, there are steps you can take to maintain the longevity of the high-voltage battery.

It is best not to begin long term storage when the high-voltage battery is at 100% state of charge. Rather, try to begin storage with the charge level at approximately 60%. Keep in mind that the battery will slowly drain while not being used. During storage, check the level monthly to ensure that it has not fallen below 20%. If this occurs, charge the battery until it reaches 30%.

NOTE:

If the ambient temperature is adjacent or below the minimum recommended storage temperature, the vehicle charge may not initiate. Have the vehicle stored in a warmer location to recharge the battery.

<i>Storage</i>
Check coolant, brake fluid and chaincase oil levels
Inflate all tires to their recommended pressure
Lubricate the brake lever and brake pedal pivot
Clean the vehicle
Charge the high-voltage propulsion battery monthly to maintain above 20% during storage
Charge the 12V battery monthly to keep it fully charged during storage (this can be done with a trickle charger if necessary)

NOTICE

The motorcycle has to be stored in a cool and dry place and covered with an opaque but ventilated tarpaulin. This will prevent sun rays and grime from affecting plastic components and vehicle finish. The recommended storage temperature is 0° C to 45° C (32° F to 113° F).

Preseason Preparation

Proper vehicle preparation is necessary when a vehicle has not been used for more than three months.

When the storage period has ended, it is best to charge the vehicle to at least 70% state of charge before the first use.

Vehicles stored during cold temperatures may require the vehicle to be connected for a longer period of time before riding.

Perform the items as directed in the Maintenance Schedule.

Visit your authorized BRP dealer for more information.

MAINTENANCE RECORDS

Send photocopies of the maintenance records to BRP if needed.

<i>Pre-delivery</i>	
Serial number: _____	Signature/Print:
Km/ Mileage: _____	
Hours: _____	
Date: _____	
Dealer no: _____	
Notes: _____	
Refer to vehicle Pre-Delivery Bulletin for detailed installation procedures	

<i>First inspection</i>	
Km/ Mileage: _____	Signature/Print:
Hours: _____	
Date: _____	
Dealer no: _____	
Notes: _____	
For maintenance schedule refer to Maintenance Information section of this operator's guide	

Service

Km/ Mileage: _____
Hours: _____
Date: _____
Dealer no: _____
Notes: _____

Signature/Print: _____

For maintenance schedule refer to Maintenance Information section of this operator's guide

Service

Km/ Mileage: _____
Hours: _____
Date: _____
Dealer no: _____
Notes: _____

Signature/Print: _____

For maintenance schedule refer to Maintenance Information section of this operator's guide

Service

Km/ Mileage:

Hours:

Date:

Dealer no:

Notes:

Signature/Print:

For maintenance schedule refer to Maintenance Information section of this operator's guide

Service

Km/ Mileage:

Hours:

Date:

Dealer no:

Notes:

Signature/Print:

For maintenance schedule refer to Maintenance Information section of this operator's guide

<i>Service</i>	
Km/ Mileage: _____	Signature/Print:
Hours: _____	
Date: _____	
Dealer no: _____	
Notes: _____	
For maintenance schedule refer to Maintenance Information section of this operator's guide	

<i>Service</i>	
Km/ Mileage: _____	Signature/Print:
Hours: _____	
Date: _____	
Dealer no: _____	
Notes: _____	
For maintenance schedule refer to Maintenance Information section of this operator's guide	

Service

Km/ Mileage:

Hours:

Date:

Dealer no:

Notes:

Signature/Print:

For maintenance schedule refer to Maintenance Information section of this operator's guide

Service

Km/ Mileage:

Hours:

Date:

Dealer no:

Notes:

Signature/Print:

For maintenance schedule refer to Maintenance Information section of this operator's guide

Service

Km/ Mileage: _____
Hours: _____
Date: _____
Dealer no: _____
Notes: _____

Signature/Print: _____

For maintenance schedule refer to Maintenance Information section of this operator's guide

Service

Km/ Mileage: _____
Hours: _____
Date: _____
Dealer no: _____
Notes: _____

Signature/Print: _____

For maintenance schedule refer to Maintenance Information section of this operator's guide

Service

Km/ Mileage:

Hours:

Date:

Dealer no:

Notes:

Signature/Print:

For maintenance schedule refer to Maintenance Information section of this operator's guide

Service

Km/ Mileage:

Hours:

Date:

Dealer no:

Notes:

Signature/Print:

For maintenance schedule refer to Maintenance Information section of this operator's guide

Service

Km/ Mileage: _____
Hours: _____
Date: _____
Dealer no: _____
Notes: _____

Signature/Print: _____

For maintenance schedule refer to Maintenance Information section of this operator's guide

Service

Km/ Mileage: _____
Hours: _____
Date: _____
Dealer no: _____
Notes: _____

Signature/Print: _____

For maintenance schedule refer to Maintenance Information section of this operator's guide

VEHICLE CARE

Vehicle Care General

Post-Operation Care

Remove dust and debris from front and rear suspension, steering mechanism, brake pedal and wheels.

Keep the motorcycle clean to improve vehicle component conditions and operations.



Make sure the key is removed before standing in front the vehicle, or getting close to the rear wheel or suspension components

Always cover your motorcycle when leaving it outside overnight or during extended periods of inactivity. This will protect it from rain, sun/UV, frost and snow as well as help retain its appearance.

Avoid leaving your motorcycle in temperatures above 40° C (104° F) or below -20° C (-4° F). Never let the vehicle fully discharge after a ride. A minimum state of charge of 30% shall be kept to avoid completely depleting the high-voltage battery energy.

Non-Compatible Cleaning Products

<i>Material Type</i>	<i>Non-Compatible Cleaning Products</i>
All plastics, vinyls, painted steel and aluminium	BRAKE AND PARTS CLEANER OR ANY PETROLEUM BASE CLEANING PRODUCTS

Compatible Cleaning Products

<i>Material Type</i>	<i>Cleaning Product</i>
All plastics, vinyls, painted steel and aluminium.	Automotive type soap with water XPS Spray Cleaner and Polish XPS All Purpose Cleaner

For more information and products, Visit the XPS Products website at www.xpslubricants.com

Vehicle Cleaning

Do not use high-pressure washers (like the ones found in car washes) as they may damage certain parts of the vehicle.

NOTICE

Do not clean the windshield with alkaline or acid cleaner, gasoline or solvent to avoid windshield damage.

NOTICE

For **matte finishes**, do not use wax, detail spray, or other products used on regular paint. Do not wash with abrasive materials. Do not use mechanical cleaners or polishers, and do not rub the surfaces vigorously.

To clean the vehicle:

1. Rinse the vehicle thoroughly with water to remove loose dirt.
2. Using a soft, clean cloth, wash the vehicle with water mixed with a mild detergent, such as soap specially formulated for motorcycles or automobiles.



NOTE

Using warm water works well to remove bugs in the windshield and front panels.

3. While washing the vehicle, check for grease or oil. You can use service product or a mild automotive degreaser. Thoroughly follow the manufacturer's instructions.

XPS Roadster wash

4. Dry the vehicle with a chamois or a soft towel.

Vehicle Protection

Apply non-abrasive wax to plastic parts.

NOTICE

Do not wax or polish matte surfaces (including matte paint finishes).

Surface	Recommendation
Glossy paint finishes	Apply only non-abrasive wax, safe for clear coat paints
Matte finishes	Do not apply wax

NOTICE

Do not polish windshield with any plastic cleaner/polisher.

WARNING

Do not apply a vinyl or plastic protector on the seat(s) or handgrips as the surfaces will become slippery and will affect the operator stability on the vehicle.

5 TECHNICAL INFORMATION - TABLE OF CONTENTS

VEHICLE IDENTIFICATION	5-2
Vehicle Identification Label	5-2
High-Voltage Battery Identification Number	5-3
COMPLIANCE LABELS	5-4
MULTIFUNCTION DISPLAY REGULATORY INFORMATION	5-5

VEHICLE IDENTIFICATION

Vehicle Identification Label

The vehicle identification label is located on the chassis, above the radiator grille.

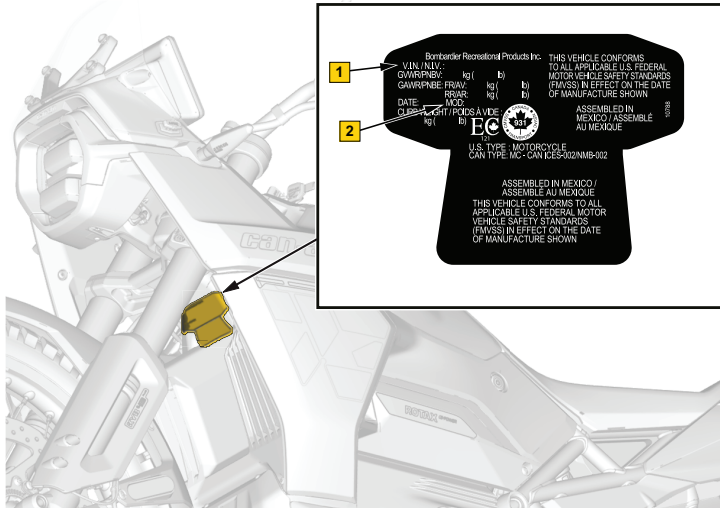

Vehicle Identification Number - Canada and USA Models

1. VIN (Vehicle Identification Number)
2. Model number

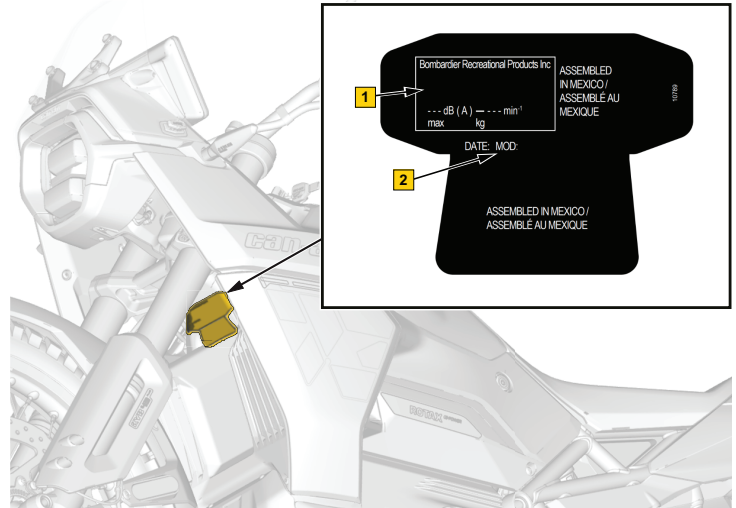

Vehicle Identification Number - All Other Models

1. VIN (Vehicle Identification Number)
2. Model number

High-Voltage Battery Identification Number

P/N:
S/N:
361VDC 8,9kWh Li-ion

Bombardier Recreational
Products Inc

Fabriqué au Canada
Made in Canada



S/N: ESSB0000PV000001



EOL test OK

5

High Voltage Battery Serial Number Label

High Voltage Battery Identification Label

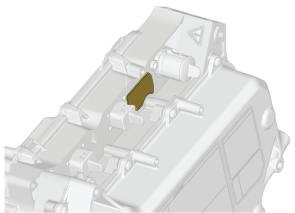

High Voltage Battery

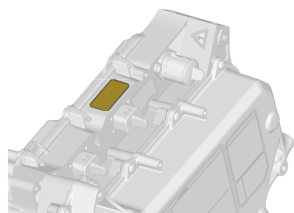





High Voltage Battery

COMPLIANCE LABELS

 **VEHICLE EMISSION CONTROL INFORMATION**
 BOMBARDIER RECREATIONAL PRODUCTS INC.
 THIS VEHICLE IS CERTIFIED TO OPERATE ON ELECTRICITY.
 THIS VEHICLE CONFORMS TO U.S. EPA AIR EMISSIONS
 REGULATIONS APPLICABLE TO MODEL YEAR
 NEW HIGHWAY MOTOCYCLES.
 NO ADJUSTMENTS NECESSARY.
 SEE OWNER'S MANUAL FOR DETAIL.
RENSEIGNEMENT SUR LE DISPOSITIF ANTIPOLLUTION
 BOMBARDIER PRODUITS RÉCRÉATIFS INC.
 CE VÉHICULE EST CERTIFIÉ POUR FONCTIONNER À
 L'ÉLECTRICITÉ. CE VÉHICULE EST CONFORME AUX
 RÉGLEMENTS SUR LES ÉMISSIONS POLLUANTES DES É.-U.
 EPA APPLICABLES AUX MOTOCYCLETTES SUR ROUTE
 NEUVES DE L'ANNÉE MODÈLE
 AUCUN AJUSTEMENT NÉCESSAIRE.
 VOIR MANUEL DU PROPRIÉTAIRE POUR PLUS DE DÉTAILS.

ENGINE FAMILY / FAMILLE DE MOTEUR:
 EXHAUST EMISSION CONTROL SYSTEM:
 BATTERY ONLY ELECTRIC VEHICLE
 SYSTÈME DE CONTRÔLE DES ÉMISSIONS D'ÉCHAPPEMENT:
 VÉHICULE ÉLECTRIQUE À BATTERIE UNIQUEMENT



 10077
 

Emission Control Label – Canada and USA Models

Emission Control Label – All Other Models

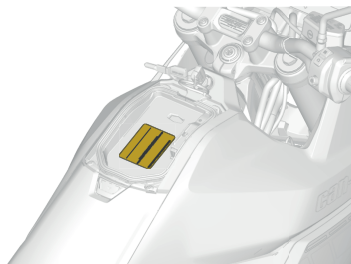

Glove Compartment

MULTIFUNCTION DISPLAY REGULATORY INFORMATION

Technical Information

Transmitter:

- BT operating frequency range: 2402 - 2480 MHz
- BT version: 5.0
- BT max transmit power: +8 dBm

Manufacturer and Address

- Enovation Controls LLC
- 5311 S 122nd E. Ave. Tulsa,
OK 74146,
USA

To display the regulatory information on the vehicle digital display: From the home screen, access the main menu and keep the joystick pressed down for more than 10 seconds.

USA and Canada

This device complies with FCC Part 15 and Industry Canada license exempt RSS standard (s). Operation is subject to the following two conditions:

- (1) this device may not cause interference, and
- (2) this device must accept any interference, including interference that may cause undesired operation of the device.

L'émetteur/récepteur exempt de licence contenu dans le présent appareil est conforme aux CNR d'Innovation, Sciences et Développement économique Canada applicables aux appareils radio exempts de licence. L'exploitation est autorisée aux deux conditions suivantes:

- (1) l'appareil ne doit pas produire de brouillage, et
- (2) l'appareil doit accepter tout brouillage radioélectrique subi, même si le brouillage est susceptible d'en compromettre le fonctionnement.

Changes or modifications not expressly approved by the party responsible for compliance could void the user's authority to operate the equipment.

IC: 28102-ECB01

FCC ID: 2A3FV-ECB01

RF exposure:

1. The equipment complies with FCC RF exposure limits set forth for an uncontrolled environment.
2. This equipment must be installed and operated with a separation distance of at least 20 cm from all persons.
3. The antenna(s) used for this transmitter must not be co-located or operating in conjunction with any other antenna or transmitter.

Mexico

IFETEL

Marca: Enovation Controls LLC

Número: RCPENOD22-2195

Modelo: OD1025-01

NOM-208-SCFI-2016 (Disposición Técnica IFT-008-2015)

La operación de este equipo está sujeta a las siguientes dos condiciones:

1. es posible que este equipo o dispositivo no cause interferencia perjudicial y
2. este equipo o dispositivo debe aceptar cualquier interferencia, incluyendo la que pueda causar su operación no deseada.

Brazil



15742-23-14024

Este equipamento não tem direito à proteção contra interferência prejudicial e não pode causar interferência em sistemas devidamente autorizados. Para maiores informações, consulte o site da ANATEL.

Japan

This device is granted pursuant to the Japanese Radio Law (電波法) and the Japanese Telecommunications Business Law (電気通信事業法). This device should not be modified (otherwise the granted designation number will become invalid).

Europe

Declaration of Conformity

Simplified EU Declaration of Conformity according Radio Equipment Directive 2014/53/EU



DE

Hiermit erklärt Enovation Controls LLC, dass der Funkanlagentyp OD1025-01 der Richtlinie 2014/53/EU entspricht.

Der vollständige Text der EU-Konformitätserklärung ist unter der folgenden Internetadresse verfügbar:

<https://www.brp.com/en/sustainability/product-responsibility.html>

FR

Le soussigné, Enovation Controls LLC, déclare que l'équipement radioélectrique du type OD1025-01 est conforme à la directive 014/53/UE.

Le texte complet de la déclaration UE de conformité est disponible à l'adresse internet suivante:

<https://www.brp.com/en/sustainability/product-responsibility.html>

BG

С настоящото Enovation Controls LLC декларира, че този тип радиосъоръжение OD1025-01 е в съответствие с Директива 2014/53/ЕС.

Цялостният текст на ЕС декларацията за съответствие може да се намери на следния интернет адрес:

<https://www.brp.com/en/sustainability/product-responsibility.html>

EL

Με την παρούσα ο/η Enovation Controls LLC, δηλώνει ότι ο ραδιοεξοπλισμός OD1025-01 πληροί την οδηγία 2014/53/ΕΕ.

Το πλήρες κείμενο της δήλωσης συμμόρφωσης ΕΕ διατίθεται στην ακόλουθη ιστοσελίδα στο διαδίκτυο:

<https://www.brp.com/en/sustainability/product-responsibility.html>

CS

Tímto Enovation Controls LLC prohlašuje, že typ rádiového zařízení OD1025-01 je v souladu se směrnicí 2014/53/EU.

Úplné znění EU prohlášení o shodě je k dispozici na této internetové adrese:

<https://www.brp.com/en/sustainability/product-responsibility.html>

DA

Hermed erklærer Enovation Controls LLC, at radioudstyrstypen OD1025-01 er i overensstemmelse med direktiv 2014/53/UE.

EU-overensstemmelseserklæringens fulde tekst kan findes på følgende internetadresse:

<https://www.brp.com/en/sustainability/product-responsibility.html>

ET

Käesolevaga deklareerib Enovation Controls LLC, et käesolev raadioseadme tüüp OD1025-01 vastab direktiivi 2014/53/EÜ nõuetele.

ELi vastavusdeklaratsiooni täielik tekst on kättesaadav järgmisel internetiaadressil: <https://www.brp.com/en/sustainability/product-responsibility.html>

ES

Por la presente, Enovation Controls LLC declara que el tipo de equipo radioeléctrico OD1025-01 es conforme con la Directiva 2014/53/UE.

El texto completo de la declaración UE de conformidad está disponible en la dirección Internet siguiente:

<https://www.brp.com/en/sustainability/product-responsibility.html>

FI

Enovation Controls LLC vakuuttaa, että radiolaitetyypin OD1025-01 on direktiivin 2014/53/EU mukainen. EU-vaatimustenmukaisuusvakuutuksen täysimittainen teksti on saatavilla seuraavassa internetosoitteessa:

<https://www.brp.com/en/sustainability/product-responsibility.html>

EN

Hereby, Enovation Controls LLC declares that the radio equipment type OD1025-01 is in compliance with Directive 2014/53/UE.

The full text of the EU declaration of conformity is available at the following internet address:

<https://www.brp.com/en/sustainability/product-responsibility.html>

HR

Enovation Controls LLC ovime izjavljuje da je radijska oprema tipa OD1025-01 u skladu s Direktivom 2014/53/EU. Cjeloviti tekst EU izjave o sukladnosti dostupan je na sljedećoj internetskoj adresi:

<https://www.brp.com/en/sustainability/product-responsibility.html>

HU

Enovation Controls LLC igazolja, hogy a OD1025-01 típusú rádióberendezés megfelel a 2014/53/EU irányelvnek. Az EU-megfelelőségi nyilatkozat teljes szövege elérhető a következő internetes címen:

<https://www.brp.com/en/sustainability/product-responsibility.html>

IT

Il fabbricante, Enovation Controls LLC, dichiara che il tipo di apparecchiatura radio OD1025-01 è conforme alla direttiva 2014/53/UE.

Il testo completo della dichiarazione di conformità UE è disponibile al seguente indirizzo Internet:

<https://www.brp.com/en/sustainability/product-responsibility.html>

LT

Aš, Enovation Controls LLC, patvirtinu, kad radijo įrenginių tipas OD1025-01 atitinka Direktyvą 2014/53/ES.

Visas ES atitikties deklaracijos tekstas prieinamas šiuo interneto adresu: <https://www.brp.com/en/sustainability/product-responsibility.html>

LV

Ar šo Enovation Controls LLC deklarē, ka radioiekārtā OD1025-01 atbilst Direktīvai 2014/53/ES. Pilns ES atbilstības deklarācijas teksts ir pieejams šādā interneta vietnē: <https://www.brp.com/en/sustainability/product-responsibility.html>

MT

B'dan, Enovation Controls LLC, niddikjara li dan it-tip ta' taghmir tar-radju OD1025-01 huwa konformi mad-Direttiva 2014/53/UE. It-test kollu tad-dikjarazjoni ta' konformita' tal-UE huwa disponibbli f'dan l-indirizz tal-Internet li ġej: <https://www.brp.com/en/sustainability/product-responsibility.html>

NL

Hierbij verklaar ik, Enovation Controls LLC, dat het type radioapparatuur OD1025-01 conform is met Richtlijn 2014/53/EU.

De volledige tekst van de EU-conformiteitsverklaring kan worden geraadpleegd op het volgende internetadres:

<https://www.brp.com/en/sustainability/product-responsibility.html>

PL

Enovation Controls LLC niniejszym oświadcza, że typ urządzenia radiowego OD1025-01 jest zgodny z dyrektywą 2014/53/UE.

Pełny tekst deklaracji zgodności UE jest dostępny pod następującym adresem internetowym:

<https://www.brp.com/en/sustainability/product-responsibility.html>

PT

O(a) abaixo assinado(a) Enovation Controls LLC declara que o presente tipo de equipamento de rádio OD1025-01 está em conformidade com a Diretiva 2014/53/UE. O texto integral da declaração de conformidade está disponível no seguinte endereço de Internet:

<https://www.brp.com/en/sustainability/product-responsibility.html>

RO

Prin prezenta, Enovation Controls LLC declară că tipul de echipamente radio OD1025-01 este în conformitate cu Directiva 2014/53/UE.

Textul integral al declarației UE de conformitate este disponibil la următoarea adresă internet:

<https://www.brp.com/en/sustainability/product-responsibility.html>

SV

Härmed försäkrar Enovation Controls LLC att denna typ av radioutrustning OD1025-01 överensstämmer med direktiv 2014/53/EU.

Den fullständiga texten till EU-försäkran om överensstämmelse finns på följande webbadress:

<https://www.brp.com/en/sustainability/product-responsibility.html>

SL

Enovation Controls LLC potrjuje, da je tip radijske opreme OD1025-01 skladen z Direktivo 2014/53/EU. Celotno besedilo izjave EU o skladnosti je na voljo na naslednjem spletnem naslovu:

<https://www.brp.com/en/sustainability/product-responsibility.html>

SK

Enovation Controls LLC týmto vyhlasuje, že rádiové zariadenie typu OD1025-01 je v súlade so smernicou 2014/53/EU.

Úplné EU vyhlásenie o zhode je k dispozícii na tejto internetovej adrese: <https://www.brp.com/en/sustainability/product-responsibility.html>

IS

Enovation Controls LLC lýsir því hér með yfir að þráðlaus fjarskiptabúnaðurinn OD1025-01 er í samræmi við tilskipun 2014/53/ESB.

Óstytta texta ESB-samræmisýrslýsingarinnar er að finna á veffanginu: <https://www.brp.com/en/sustainability/product-responsibility.html>

Liechtenstein

Hiermit erklärt Enovation Controls LLC, dass der Funkanlagentyp OD1025-01 der Richtlinie 2014/53/EU entspricht.

Der vollständige Text der EU-Konformitätserklärung ist unter der folgenden Internetadresse verfügbar:

<https://www.brp.com/en/sustainability/product-responsibility.html>

NO

Herved erklærer Enovation Controls LLC at radioutstyrstypen OD1025-01 er i samsvar med direktiv 2014/53/EU.

Hele teksten i EU-samsvarserklæringen finnes på følgende internetadresse: <https://www.brp.com/en/sustainability/product-responsibility.html>

RU

Компания Enovation Controls LLC настоящим заявляет, что радиотехническое оборудование категории OD1025-01 отвечает требованиям Директивы 2014/53/ЕU. Полный текст декларации соответствия ЕС доступен на сайте

<https://www.brp.com/en/sustainability/product-responsibility.html>

6 TECHNICAL SPECIFICATIONS - TABLE OF CONTENTS

TECHNICAL SPECIFICATIONS.....6-2

TECHNICAL SPECIFICATIONS

Because of our ongoing commitment to product quality and innovation, BRP reserves the right, at any time, to make changes in design and specifications and/or to make additions to, or improvements in its products without imposing any obligation upon itself to install them on its previously manufactured products.

HIGH-VOLTAGE POWER UNIT			
Charging Port Connector	North America		Type 1 - SAE J1772
	International		Type 2 - IEC 62196
E-Motor	Motor type		ROTAX® E-POWER
	Heat Management		Liquid Cooled
	Current		High-Voltage 3-phased AC
	Power	Standard	35 kW
		A1 License (Continuous)	11 kW
	Torque	Standard	72 Nm (53 lbs-ft) From 0 to 4600 RPM
		A1 License	48 Nm (35 lbs-ft) From 0 to 4600 RPM
Top speed		129 km/h (80 MPH)	
Inverter	Heat Management		Liquid Cooled

HIGH-VOLTAGE POWER UNIT

	Input Current - E-Motor (Regen)		High-Voltage 3-phased AC
	Input Current - High-Voltage Battery		High-Voltage DC
	Output Current - E-Motor		High-Voltage 3-phased AC
	Output Current - High-Voltage Battery (Regen)		High-Voltage DC
High-Voltage Battery	Capacity		8,9 kWh
	Estimated Range	City	145 km (90 miles)
		Combined (WMTC)	115 km (71 miles)
		Sustained 80 kmh (50 MPH)	84 km (52 miles)
On-Board Charger	Heat Management		Liquid Cooled
	Input Voltage		120 and 240 VAC

COOLING SYSTEM

Coolant type	Recommended	XPS Extended life pre-mixed coolant
	Alternative, or if not available	Ethyl glycol and distilled water (50%/50%) or coolant specifically formulated for electric vehicles
Quantity	3.4 l (3.6 qt (US))	

ELECTRICAL SYSTEM – LOW VOLTAGE

12V Battery		12 V, 6 A•h	
Headlamp		LED	
Taillight and stoplight		LED	
Fuses	F1	Ignition/ Multifunction display / Charger	10 A
	F2	Horn / High Beam	7.5 A
	F3	Low Beam / Brake / Plate	5 A
	F4	VCU / Wake-Up	10 A
	F5	Cooling fans / Cooling pump	7.5 A
	F6	Main	20 A
	F7	Accessories	10 A
	F8	Multi switches / Tail lamp	5 A
	F9	ABS pump	25 A
	F10	ABS valves	10 A
Relays	RY1	Main	-
	RY2	Lighting	-
	RY3	High Beam	-
	RY4	Horn	-

DRIVE SYSTEM — CHAINCASE			
Drive system oil	Type	Recommended	XPS 75W-140 synthetic gear oil
		Alternative, or if not available	75W140 gear oil that meets the API GL-5 specification
	Capacity	350 ml (11.8 fl oz (US))	
Chain drive ratio		First ratio gear: 23/129	
		Second ratio chain/sprocket: 21/40	

STEERING	
Steering Type	Conventional
Rake Angle	30°
Trail	118 mm (4.6 in)

FRONT SUSPENSION		
Suspension type		KYB 43 mm Inverted Fork
Suspension travel		255 mm (10 in)
Shock absorber	QTY	2
	Type	Oil damper

FRONT SUSPENSION

	Oil capacity	0.487 cm ³ (0.017 fl oz (US))
	Oil Type	5W
Adjustment type		No adjustment

REAR SUSPENSION

Suspension type		KYB HPG shocks Adj
Suspension travel		255 mm (10 in)
Shock absorber	QTY	1
	Type	Coil spring / oil damper
Adjustment type		Preload, Compression and Rebound

BRAKES

Type	Front and rear independent braking system with ABS	
Front brake	Single 320 mm (12.6 in) disc, with 2 pistons floating caliper	
Rear brake	Single 240 mm (9.5 in) disc with 1 piston floating caliper	

BRAKES		
Brake fluid	Type	DOT 4
	Capacity	200 cm ³ (6.76 fl oz (US))
Caliper		Floating
Brake pad material		Sintered SBS-SI-104HH
Minimum brake pad thickness		1 mm (.04 in)
Minimum brake disc thickness		4.5 mm (.177 in)
Maximum brake disc warpage		0.03 mm (.001 in)

TIRES		
Type (use only tires recommended by BRP)	Front	Dunlop D605 90/90-R21 (with tube)
	Rear	Dunlop D605 120/80-R18 (with tube)
Pressure	Front	165 kPa (24 PSI)
	Rear	207 kPa (30 PSI)
Minimum tire tread depth	Front and rear	As per tire tread wear indicator

WHEELS

Type		Aluminium spoked wheel	
Rim size		Front	533 mm x 47 mm (21 in x 1.85 in)
		Rear	457 mm x 64 mm (18 in x 2.5 in)
Front wheel	Torque	Wheel axle	36 ± 4 Nm (26.5 ± 3 lbf-ft)
		Axle pinch bolts	22.5 ± 2.5 Nm (16.5 ± 1.88 lbf-ft)
Rear wheel	Torque	Wheel Nuts	80 ± 5 Nm (59 ± 3.69 lbf-ft)

DIMENSIONS

Overall length	2 204 mm (86.8 in)
Overall width	861 mm (33.9 in)
Overall height	1 414 mm (55.7 in)
Seat height	865 mm (34 in)

DIMENSIONS

Wheelbase	1 503 mm (59 in)
Ground clearance	274 mm (10.8 in)

WEIGHT AND LOADING CAPACITY

Wet weight (all liquids)	187 kg (412 lb)	
Glove box	0.7 l (0.7 qt)	
Total rear cargo load (LinQ) without passenger seat	30 kg (66 lb)	
Total vehicle payload allowed (including driver, passenger*, all cargo loads and added accessories)	151 kg (333 lb)	
Gross vehicle weight rating (GVWR)	338 kg (745 lb)	
Gross axle weight rating (GAWR)	Front	149 kg (328 lb)
	Rear	189 kg (417 lb)

* BRP passenger's seat kit required

7 TROUBLESHOOTING - TABLE OF CONTENTS

ROAD SIDE REPAIRS	7-2
What to do in the following circumstances	7-2
TROUBLESHOOTING GUIDELINES – ELECTRIC MOTORCYCLES	7-4
MONITORING SYSTEM	7-6
Pilot Lamps, Messages and Beeper Codes	7-6
Fault Codes	7-9
On Board Diagnostic (OBD) Connector	7-10

ROAD SIDE REPAIRS

What to do in the following circumstances

Lost Keys

An additional uncut blank key can be order at an authorized Can-Am On-Road dealer. Use your spare key to have another one made by an authorized locksmith or where this service is available, using the uncut blank key. **If both keys are lost**, the key switch will need to be replaced at the expense of the vehicle owner.

Flat Tire

If a tire is deflated, it may have an internal tube damage with a **major** puncture or cut in the tread or a **minor** nail or stone puncture in the tire. Have the vehicle transported to the nearest Can-Am On-Road dealer for tire repair. Refer to [Transporting the Vehicle, page 2-21](#) for transporting instructions.

Discharged 12V Battery

If the low voltage battery is discharged or too low to activate the vehicle, it can be jump started as follows:

WARNING

Batteries can emit explosive gas that can ignite if jumper cables are not properly connected.
Connect the jumper cables as specified in the procedure that follows.

NOTICE

Do not disconnect the discharged battery.

1. Immobilize the motorcycle, deploy the side stand and press the stop switch in the OFF position.
2. Park the booster vehicle close to the rear of the motorcycle.
3. Open the glove compartment cover.
4. Remove the driver seat using the tool kit.

- Remove the positive terminal cover and clean corrosion from battery posts before connecting the jumper cables.

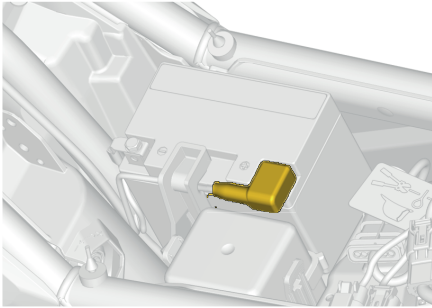

- Connect one end of the RED jump lead to the positive (+) post of the discharged battery.
- Connect the other end of the RED jump lead to the positive (+) post of the booster vehicle battery.
- Connect one end of the BLACK jump lead to the negative (-) post of the discharged battery.
- Connect the other end of the BLACK jump lead to the negative (-) post of the booster vehicle battery.
- Start the booster vehicle and let run to idle.
- Turn the motorcycle key to ON, **Do not activate the propulsion system**; If the motorcycle does not start, wait a few minutes

before repeating the attempt in order to protect the low and/or high voltage system(s).

 NOTE

If the vehicle shut down with the key to ON, there might be a problem with the low and / or the high voltage electrical system (s). Have the vehicle transported (see *Transporting the Vehicle* in this section) and repaired by an authorized Cam-Am dealer.

- Once the motorcycle is started, let run booster vehicle to idle for a few minutes before disconnecting the jumper cables.
- Remove the jumper cables in the reverse order that they were connected.
- Have the battery fully recharged with a battery charger (see *Maintenance Procedures*) or by a qualified service station as soon as possible.

After recharging battery, have the vehicle inspected by an authorized Can-Am On-Road dealer.

TROUBLESHOOTING GUIDELINES – ELECTRIC MOTORCYCLES

ELECTRIC VEHICLE DOES NOT TURN ON

- 1. 12V battery is too low.**
 - *A 12V battery charger can be used to charge the 12V battery.*
 - *A booster vehicle can be used to jump start the motorcycle.*
 - *Contact an authorized BRP dealer.*

VEHICLE LACKS ACCELERATION OR POWER

The  icon is displayed in the multifunction display due to a system malfunction.

- 1. High-voltage propulsion system error.**
 - *Plug in the vehicle.*
 - *Contact an authorized BRP dealer.*
- 2. High-voltage propulsion system is in limited performance mode.**
 - *Check coolant temperature and level. Refer to [Maintenance Procedures, page 4-8](#).*
 - *Check radiator cleanliness. Clean if necessary.*
 - *Check the coolant pump activation under normal and charging operation.*

VEHICLE HAS SHUT DOWN

- 1. The vehicle charge is completed.**
 - *Insert and turn the key ON.*
 - *Disconnect the charge cable from the vehicle charging port.*
- 2. 12V battery is too low.**
 - *A 12V battery charger can be used to charge the 12V battery.*
 - *A booster vehicle can be used to jump start the motorcycle.*
 - *Contact an authorized BRP dealer.*

VEHICLE CANNOT BE CHARGED

- 1. The ambient temperature is too low.**
 - *Wait for the ambient temperature to increase, if possible, or have the vehicle moved to a warmer location, and charge the HV battery.*
- 2. The high-voltage propulsion system temperature is too high.**
 - *Check the coolant level. Refer to [Maintenance Procedures, page 4-8](#).*
 - *If the coolant level is correct, keep the vehicle connected to the EVSE. The vehicle cooling system will cool down the HV propulsion system, allowing the charge to be restored.*
 - *If the coolant level is not correct, disconnect the vehicle from the EVSE and, contact an authorized BRP dealer.*
- 3. The vehicle charging system has a malfunction or cannot communicate with the EVSE.**
 - *Ensure the charging cable is properly connected and locked to the vehicle charging port.*
 - *Ensure the EVSE is powered and functioning correctly.*
 - *Contact an authorized BRP dealer.*

MONITORING SYSTEM

Pilot Lamps, Messages and Beeper Codes

Multifunction display pilot lamp(s), messages and Beeper Codes will inform you if an anomaly occurs or to inform you of a particular condition.

A telltale can flash alone or in combination with another lamp.

Some messages will be displayed with a beep code and telltale(s).

Beeper codes will be heard and messages will be displayed to catch your attention.

The telltales lights are found in two (2) locations of the multifunction display:

- Physical bar
- Digital Touchscreen

Physical bar

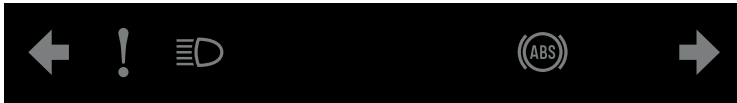











Pilot Lamps – 10.25” Color Digital Touchscreen



Digital Touchscreen



DIGITAL PILOT LAMP - 10.25" COLOR DIGITAL TOUCHSCREEN

<i>Pilot lamp ON</i>	<i>Beeper</i>	<i>Message display</i>	<i>Description</i>
	—	12V BATTERY / LOW BATTERY VOLTAGE	Low voltage system has a low voltage. If this happens while riding, vehicle may shutdown soon.
	—	12V BATTERY / HIGH BATTERY VOLTAGE	Low voltage system has a high voltage.
	1 short beep	PROPULSION BATTERY / OVERHEAT	Propulsion battery temperature is over 58 °C.
	1 short beep	ELECTRICAL FAULT / SERVICE REQUIRED	An electrical fault or high voltage interlock fault is detected.
	1 long beep	EMERGENCY SHUTDOWN / PARK IN A SAFE PLACE AND GET OFF THE VEHICLE	Critical error in the propulsion battery causing the vehicle to shutdown.
	—	—	Failure in the propulsion battery.

Pilot lamp ON	Beeper	Message display	Description
	1 short beep	PROPULSION BATTERY / LOW STATE OF CHARGE - CHARGE NOW	Propulsion battery state of charge is at 0%.
	—	CHARGING SYSTEM / SYSTEM UNABLE TO CHARGE	There is a problem with the charging system that is stopping the charge.
	slow repetitive beeps	CHARGING STATION / UNABLE TO CHARGE - CHECK CHARGE HANDLE	Vehicle cannot charge because the charge handle is not connected properly
	—	CHARGING STATION / VEHICLE IS UNABLE TO CHARGE	There is a problem with the electric vehicle supply equipment that is stopping the charge.
	—	—	The vehicle is connected to an EVSE and not charging due to a fault.
	1 short beep	PROPULSION SYSTEM / AUTOMATIC POWER REDUCTION	Limited power mode activated due to system malfunction.
	1 long beep	EMERGENCY SHUTDOWN / PARK IN A SAFE PLACE	Critical condition causing the vehicle control unit (VCU) to order an immediate shutdown or the e-motor cannot give torque.
	1 short beep	ELECTRIC MOTOR / OVERHEAT	The high voltage e-motor internal temperature is above optimal temperature range.
	—	—	Failure in the torque generator unit or high-voltage propulsion system.
	—	VEHICLE TIPPED / PLACE VEHICLE IN AN UPRIGHT POSITION AND CYCLE THE KEY FOR RESET	The motorcycle has tipped. The e-motor torque has been disabled and the hazards are automatically activated.
	—	—	The coolant temperature is high.

<i>Pilot lamp ON</i>	<i>Beeper</i>	<i>Message display</i>	<i>Description</i>
	—	ICY ROAD / POSSIBLE PRESENCE OF ICE	The ambient temperature is below 0 deg C.
	—	—	Service is required.
—	—	REAR ABS OFF / OFF-ROAD DRIVE MODES DEACTIVATE REAR ABS FUNCTIONALITY	When Offroad or Offroad + drive modes are selected, the rear ABS is deactivated.
—	—	DRIVE DEACTIVATION / PRESS BRAKE TO KEEP THE VEHICLE READY TO DRIVE	The vehicle will automatically go in neutral because there were no user interaction for more then 5 minutes.
—	—	PROPULSION BATTERY / HIGH TEMPERATURE - COOLING DOWN	The temperature is too high and full charging capacity is not available.
—	—	SIDE STAND LOWERED / RAISE SIDE STAND	The side stand is lowered while riding.
—	—	RELEASE ACCELERATOR / RELEASE ACCELERATOR TO CONFIRM DRIVE MODE CHANGE	The accelerator handle needs to be released to change the drive mode.
—	—	CHANGE NOT AVAILABLE / DRIVE MODE CHANGE NOT AVAILABLE	The conditions to change the driving mode are not met.

Fault Codes

The fault codes can be displayed on the multifunction display.

Access the Vehicle Setting Menu in the Multifunction Display and select the Health Monitoring Menu to consult code descriptions. Refer to [Multifunction display, page 3-34](#).

Contact an authorized BRP Can-Am On-Road dealer for code signification.

On Board Diagnostic (OBD) Connector

The on board diagnostic connector can be used to consult the vehicle fault codes. It is located in the driver seat compartment.

Refer to the OBD manufacturer instructions for connection and diagnostic procedures.

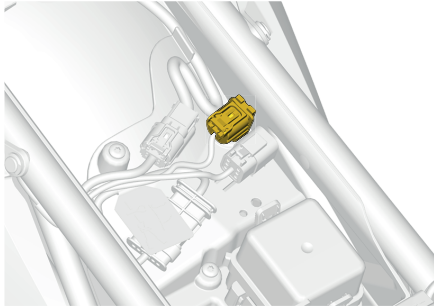

OBD connector location

8 WARRANTY - TABLE OF CONTENTS

**BRP LIMITED WARRANTY CANADA AND USA: 2025
CAN-AM® ELECTRIC MOTORCYCLE.....8-2**

**BRP INTERNATIONAL LIMITED WARRANTY: 2025 CAN-
AM® ELECTRIC MOTORCYCLES8-9**

**BRP LIMITED WARRANTY FOR THE EUROPEAN
ECONOMIC AND THE COMMONWEALTH OF THE
INDEPENDENT STATES (CIS) AREAS AND TURKEY: 2025
CAN-AM® ELECTRIC MOTORCYCLES 8-17**

BRP LIMITED WARRANTY CANADA AND USA: 2025 CAN-AM® ELECTRIC MOTORCYCLE

1) SCOPE OF THE LIMITED WARRANTY

Bombardier Recreational Products Inc. (“**BRP**”) warrants its 2025 Can-Am electric motorcycles (the “**Product**”) and its high-voltage batteries sold by authorized BRP dealers in the United States of America (“**USA**”) and in Canada (“**BRP Dealer**”) from defects in material or workmanship for the period and under the conditions described below.

This limited warranty will become null and void if:

1. The Product was used for racing or any other competitive activity, at any point, even by a previous owner;
2. The Product has been altered or modified in such a way so as to adversely affect its operation, performance or durability, or has been altered or modified to change its intended use;
3. The Product has been altered or modified in such a way so as to adversely affect the high-voltage battery operation, performance or durability;
4. The Product’s high-voltage battery has been used as a stationary power source.

The on-board charger, inverter, and e-motor are covered under the vehicle’s limited warranty period against defects in material or workmanship.

Non-factory installed parts and accessories are not covered under this limited warranty. Please refer to the applicable parts and accessories limited warranty text.

2) LIMITATIONS OF LIABILITY

TO THE EXTENT PERMITTED BY LAW, THIS WARRANTY IS EXPRESSLY GIVEN AND ACCEPTED IN LIEU OF ANY AND ALL OTHER WARRANTIES, EXPRESSED OR IMPLIED, INCLUDING WITHOUT LIMITATION ANY WARRANTY OF MERCHANTABILITY OR FITNESS FOR A PARTICULAR PURPOSE. TO THE EXTENT THAT THEY CANNOT BE DISCLAIMED, THE IMPLIED WARRANTIES ARE LIMITED IN DURATION TO THE LIFE OF THE EXPRESS WARRANTY. INCIDENTAL AND CONSEQUENTIAL DAMAGES ARE EXCLUDED FROM COVERAGE UNDER THIS WARRANTY. SOME STATES/ PROVINCES DO NOT ALLOW FOR THE DISCLAIMERS, LIMITATIONS AND EXCLUSIONS IDENTIFIED ABOVE. AS A RESULT, THEY MAY NOT APPLY TO YOU. THIS WARRANTY GIVES YOU SPECIFIC RIGHTS, AND YOU MAY ALSO HAVE OTHER LEGAL RIGHTS WHICH MAY VARY FROM STATE TO STATE, OR PROVINCE TO PROVINCE.

Neither the distributor, any BRP Dealer nor any other person has been authorized to make any affirmation, representation or warranty regarding the Product and/or its high-voltage battery, other than those contained in this limited warranty, and if made, shall not be enforceable against BRP.

BRP reserves the right to modify this limited warranty at any time, being understood that such modification will not alter the warranty conditions applicable to the products and/or its high-voltage batteries sold while this warranty is in effect.

3) EXCLUSIONS – ARE NOT WARRANTED

This warranty does not cover damage or failures resulting from or caused by:

- Attempting to modify the on-board charger, inverter and/or e-motor, to gain faster charge times or increase the original power output will void the warranty.
- Opening any of the high voltage components such as high voltage battery, on-board charger, inverter and e-motor.
- Improper towing or vehicle recovery from a depleted high voltage battery or other failure may damage the e-motor or other high voltage components. Failure to follow the recommended towing and/or recovery method prescribed in this manual will void the warranty.

The following are not warranted under any circumstances:

- Normal wear and tear;
- Routine maintenance items, tune ups, adjustments;
- Damage resulting from removal of parts, improper repairs, service, maintenance, modifications or use of parts or accessories not manufactured or approved by BRP or resulting from repairs done by a person that is not an authorized servicing BRP Distributor/Dealer;
- Damage caused by abuse, abnormal use, neglect or operation of the Product in a manner inconsistent with the recommended operation described in the Product's Operator's Guide;
- Damage resulting from accident, submersion, fire, theft, vandalism or any act of God;
- Operation with chemicals, oils or lubricants which are not suitable for use with the product (see the Operator's Guide);
- Damages from rust, corrosion or exposure to the elements;
- Damage resulting from water or snow ingestion;
- Incidental or consequential damages, or damages of any kind including without limitation towing, storage, telephone, rental, taxi, inconvenience, insurance coverage, loan payments, loss of time, loss of income;
- Damage resulting from corrosion from road salts, battery acid, environmental influences or treatment contrary to the Operator's Guide;
- Damages related to the appearance of the Product, including without limitation scratches, dents, fading, flaking, peeling and damages to seat cover material;
- Damage resulting from the installation of parts with specifications that differ from the original Product parts, such as, without limitation, different tires, wheels or brakes.
- Damage or failures due to the installation of non-BRP accessories to the electrical systems of the Can-Am motorcycle.
- Damage caused by failure to provide proper maintenance and/or storage, as described in the Operator's Guide. Ambient temperatures above 40 °C (104 °F) or below —20 °C (-4 °F) may damage the high-voltage battery and void the warranty;
- Damage caused by exposing the high voltage battery to contact with a direct flame;
- Physical damage to the high voltage battery or intentional attempt to reduce the life of the high voltage battery;

-
- Damage to internal components resulting from disassembly, opening the high-voltage battery enclosure is strictly forbidden;
 - Damage resulting from incorrect charging procedures or incompatible charging devices;
 - Damage to vehicle's components resulting from a complete discharge of the high-voltage battery;
 - Consequential damage caused by the failure to repair an existing problem;
 - Damage resulting from failure to install a software update;
 - Loss of battery capacity due to or resulting from gradual capacity loss.⁽¹⁾

⁽¹⁾Any capacity/range reduction-based claim must be confirmed by and approved by BRP to be eligible for coverage.

4) WARRANTY COVERAGE PERIOD

The vehicle limited warranty will be in effect from (1) the date of delivery to the first retail consumer, or (2) the date the Product is first put into use, whichever occurs first and for the applicable period below:

1. **TWENTY-FOUR (24) consecutive months**, for private use and **TWELVE (12) consecutive months**, for commercial use owners, except for the items covered in points (2) to (3) below.
2. For the tires, **SIX (6) CONSECUTIVE MONTHS** or until tires are worn to the last three thirty-seconds of an inch (3/32") (2.38 millimeters) for the front tires and the last five thirty-seconds of an inch (5/32") (3.97 millimeters) for the rear tire, whichever occurs first.
3. The high-voltage battery limited warranty will be in effect for **SIXTY (60) consecutive months**, or **fifty thousand kilometers (50,000 km) or (31,250 mi)**, whichever occurs first, **only** if the high-voltage battery state of health (SOH) is equal or greater than (\geq) seventy percent (70%) of initial capacity.

The repair or replacement of parts or the performance of service under this warranty does not extend the life of this warranty beyond its original expiration date. Loss of battery capacity resulting from gradual capacity loss is NOT covered under this warranty beyond the terms and limit specified above.

5) CONDITIONS REQUIRED FOR WARRANTY COVERAGE

This warranty coverage is available **only** if each of the following conditions has been fulfilled:

- The Product must be purchased as new and unused by its first owner from a BRP Dealer authorized to distribute the Product in the country in which the sale occurred;
- The BRP specified pre-delivery inspection process must be completed and documented and signed by the purchaser;
- The Product must have undergone proper registration by an authorized BRP Dealer;
- The Product must be purchased in the country in which the purchaser resides;
- Routine maintenance outlined in the Operator's Guide must be timely performed in order to maintain warranty coverage. BRP reserves the right to make warranty coverage contingent upon proof of proper maintenance.

BRP will not honor this limited warranty to any owner if one of the preceding conditions has not been met. Such limitations are necessary in order to allow BRP to preserve both the safety of its products, and also that of its consumers and the general public.

6) WHAT TO DO TO OBTAIN WARRANTY COVERAGE

The customer and/or commercial operator must cease using the Product upon the appearance of an anomaly, notify a servicing BRP Dealer or BRP directly within three (3) days of the appearance of the anomaly and provide the BRP Dealer with reasonable access to the Product and reasonable opportunity to repair it.

All parts replaced under this limited warranty become the property of BRP.

7) WHAT BRP WILL DO

BRP's obligations under this warranty are limited to, at its sole discretion, repairing parts found defective under normal use, maintenance and service, or replacing such parts without charge for parts and labor, at any authorized BRP Dealer during the warranty coverage period under the conditions described herein. No claim of breach of warranty shall be cause for cancellation or rescission of the sale of the Product to the owner.

BRP reserves the right to improve or modify products from time to time without assuming any obligation to modify products previously manufactured.

8) TRANSFER

If the ownership of a product is transferred during the warranty coverage period, this limited warranty, subject to its terms and conditions, will NOT be transferred to the new owner.

9) CONSUMER ASSISTANCE

In the event of a controversy or a dispute in connection with this limited warranty, BRP suggests that you try to resolve the issue at the dealership level. We recommend discussing the issue with the authorized BRP Dealer's service manager or owner.

If the matter still remains unresolved, contact BRP by filling out the customer contact form at www.brp.com or contact BRP by mail at one of the addresses listed under the [Contact Us](#) section of this guide.

BRP INTERNATIONAL LIMITED WARRANTY: 2025 CAN-AM® ELECTRIC MOTORCYCLES

1) SCOPE OF THE LIMITED WARRANTY

Bombardier Recreational Products Inc. (“**BRP**”) warrants its 2025 Can-Am electric motorcycles (the “**Product**”) sold by distributors or dealers authorized by BRP to distribute the Product outside of the fifty United States, Canada, members of the European Economic Area (which is comprised of the member states of the European Union plus the United Kingdom, Norway, Iceland and Liechtenstein) (“**EEA**”), members states of the Commonwealth of the Independent States (including Ukraine and Turkmenistan) (“**CIS**”) and Turkey (“**BRP Distributor/Dealer**”), from defects in material or workmanship for the period and under the conditions described below.

This limited warranty will become null and void if:

1. The Product was used for racing or any other competitive activity, at any point, even by a previous owner;
2. The Product has been altered or modified in such a way so as to adversely affect its operation, performance or durability, or has been altered or modified to change its intended use;
3. The Product has been altered or modified in such a way so as to adversely affect the high-voltage battery operation, performance or durability;
4. The Product’s high-voltage battery has been used as a stationary power source.

The on-board charger, inverter, and e-motor are covered under the vehicle’s limited warranty period against defects in material or workmanship.

Non-factory installed parts and accessories are not covered under this limited warranty. Please refer to the applicable parts and accessories limited warranty text.

2) LIMITATIONS OF LIABILITY

TO THE EXTENT PERMITTED BY LAW, THIS WARRANTY IS EXPRESSLY GIVEN AND ACCEPTED IN LIEU OF ANY AND ALL OTHER WARRANTIES, EXPRESSED OR IMPLIED, INCLUDING WITHOUT LIMITATION ANY WARRANTY OF MERCHANTABILITY OR FITNESS FOR A PARTICULAR PURPOSE. TO THE EXTENT THAT THEY CANNOT BE DISCLAIMED, THE IMPLIED WARRANTIES ARE LIMITED IN DURATION TO THE LIFE OF THE EXPRESS WARRANTY. INCIDENTAL AND CONSEQUENTIAL DAMAGES ARE EXCLUDED FROM COVERAGE UNDER THIS WARRANTY. SOME JURISDICTIONS DO NOT ALLOW FOR THE DISCLAIMERS, LIMITATIONS AND EXCLUSIONS IDENTIFIED ABOVE. AS A RESULT, THEY MAY NOT APPLY TO YOU. THIS WARRANTY GIVES YOU SPECIFIC RIGHTS, AND YOU MAY ALSO HAVE OTHER LEGAL RIGHTS WHICH MAY VARY FROM COUNTRY TO COUNTRY. BRP SHALL NOT BE HELD LIABLE IF PRODUCTS OR WARRANTY PARTS ARE NOT AVAILABLE IN YOUR COUNTRY FOR REASONS OUTSIDE OF BRP'S CONTROL. (FOR PRODUCTS PURCHASED IN AUSTRALIA REFER TO "FOR PRODUCTS SOLD IN AUSTRALIA ONLY",BELOW).

Neither the BRP Distributor/Dealer nor any other person has been authorized to make any affirmation, representation or warranty regarding the Product and/or its high-voltage battery, other than those contained in this limited warranty, and if made, shall not be enforceable against BRP.

BRP reserves the right to modify this limited warranty at any time, being understood that such modification will not alter the warranty conditions applicable to the products and/or its high-voltage batteries sold while this warranty is in effect.

3) EXCLUSIONS – ARE NOT WARRANTED

This warranty does not cover damage or failures resulting from or caused by:

- Attempting to modify the on-board charger, inverter and/or e-motor, to gain faster charge times or increase the original power output will void the warranty.
- Opening any of the high voltage components such as high voltage battery, on-board charger, inverter and e-motor.
- Improper towing or vehicle recovery from a depleted high voltage battery or other failure may damage the e-motor or other high voltage components. Failure to follow the recommended towing and/or recovery method prescribed in this manual will void the warranty.

The following are not warranted under any circumstances:

- Normal wear and tear;
- Routine maintenance items, tune ups, adjustments;
- Damage resulting from removal of parts, improper repairs, service, maintenance, modifications or use of parts or accessories not manufactured or approved by BRP or resulting from repairs done by a person that is not an authorized servicing BRP Distributor/Dealer;
- Damage caused by abuse, abnormal use, neglect or operation of the Product in a manner inconsistent with the recommended operation described in the Product's Operator's Guide;
- Damage resulting from accident, submersion, fire, theft, vandalism or any act of God;
- Operation with chemicals, oils or lubricants which are not suitable for use with the product (see the Operator's Guide);
- Damages from rust, corrosion or exposure to the elements;
- Damage resulting from water or snow ingestion;
- Incidental or consequential damages, or damages of any kind including without limitation towing, storage, telephone, rental, taxi, inconvenience, insurance coverage, loan payments, loss of time, loss of income;
- Damage resulting from corrosion from road salts, battery acid, environmental influences or treatment contrary to the Operator's Guide;
- Damages related to the appearance of the Product, including without limitation scratches, dents, fading, flaking, peeling and damages to seat cover material;
- Damage resulting from the installation of parts with specifications that differ from the original Product parts, such as, without limitation, different tires, wheels or brakes.
- Damage or failures due to the installation of non-BRP accessories to the electrical systems of the Can-Am motorcycle.
- Damage caused by failure to provide proper maintenance and/or storage, as described in the Operator's Guide. Ambient temperatures above 40 °C (104 °F) or below —20 °C (-4 °F) may damage the high-voltage battery and void the warranty;
- Damage caused by exposing the high voltage battery to contact with a direct flame;
- Physical damage to the high voltage battery or intentional attempt to reduce the life of the high voltage battery;

- Damage to internal components resulting from disassembly, opening the high-voltage battery enclosure is strictly forbidden;
- Damage resulting from incorrect charging procedures or incompatible charging devices;
- Damage to vehicle's components resulting from a complete discharge of the high-voltage battery;
- Consequential damage caused by the failure to repair an existing problem;
- Damage resulting from failure to install a software update;
- Loss of battery capacity due to or resulting from gradual capacity loss.⁽¹⁾

⁽¹⁾Any capacity/range reduction-based claim must be confirmed by and approved by BRP to be eligible for coverage.

4) WARRANTY COVERAGE PERIOD

The vehicle limited warranty will be in effect from (1) the date of delivery to the first retail consumer, or (2) the date the Product is first put into use, whichever occurs first and for the applicable period below:

1. **TWENTY-FOUR (24) consecutive months**, for private use and **TWELVE (12) consecutive months**, for commercial use owners, except for the items covered in points (2) to (3) below.
2. For the tires, **SIX (6) CONSECUTIVE MONTHS** or until tires are worn to the last three thirty-seconds of an inch (3/32") (2.38 millimeters) for the front tires and the last five thirty-seconds of an inch (5/32") (3.97 millimeters) for the rear tire, whichever occurs first.
3. The high-voltage battery limited warranty will be in effect for **SIXTY (60) consecutive months**, or **fifty thousand kilometers (50,000 km) or (31,250 mi)**, whichever occurs first, **only** if the high-voltage battery state of health (SOH) is equal or greater than (\geq) seventy percent (70%) of initial capacity.

The repair or replacement of parts or the performance of service under this warranty does not extend the life of this warranty beyond its original expiration date. Loss of battery capacity resulting from gradual capacity loss is NOT covered under this warranty beyond the terms and limit specified above.

FOR PRODUCTS SOLD IN AUSTRALIA ONLY

Nothing in these warranty terms and conditions should be taken to exclude, restrict or modify the application of any condition, warranty, guarantee, right or remedy conferred or implied under the Competition and Consumer Act 2010 (Cth), including the Australian Consumer Law or any other law, where to do so would contravene that law, or cause any part of these terms and conditions to be void. The benefits given to you under this limited warranty are in addition to other rights and remedies that you have under Australian law.

Our goods come with guarantees that cannot be excluded under the Australian Consumer Law. You are entitled to a replacement or refund for a major failure and for compensation for any other reasonably foreseeable loss or damage. You are also entitled to have the goods repaired or replaced if the goods fail to be of acceptable quality and the failure does not amount to a major failure.

5) CONDITIONS REQUIRED FOR WARRANTY COVERAGE

This warranty coverage is available **only** if each of the following conditions has been fulfilled:

- The Product must be purchased as new and unused by its first owner from a BRP Distributor/Dealer authorized to distribute the Product in the country in which the sale occurred;
- The BRP specified pre-delivery inspection process must be completed and documented and signed by the purchaser;
- The Product must have undergone proper registration by an authorized BRP Distributor/Dealer;
- The Product must be purchased in the country in which the purchaser resides;
- Routine maintenance outlined in the Operator's Guide must be timely performed in order to maintain warranty coverage. BRP reserves the right to make warranty coverage contingent upon proof of proper maintenance.

BRP will not honor this limited warranty to any use owner if one of the preceding conditions has not been met. Such limitations are necessary in order to allow BRP to preserve both the safety of its products, and also that of its consumers and the general public.

6) WHAT TO DO TO OBTAIN WARRANTY COVERAGE

The customer and/or commercial operator must cease using the Product upon the appearance of an anomaly, notify a servicing BRP Distributor/Dealer or BRP directly within three (3) days of the appearance of the anomaly and provide the BRP Distributor/Dealer with reasonable access to the Product and reasonable opportunity to repair it.

All parts replaced under this limited warranty become the property of BRP.

7) WHAT BRP WILL DO

BRP's obligations under this warranty are limited to, at its sole discretion, repairing parts found defective under normal use, maintenance and service, or replacing such parts without charge for parts and labor, at any authorized BRP Distributor/Dealer during the warranty coverage period under the conditions described herein. No claim of breach of warranty shall be cause for cancellation or rescission of the sale of the Product to the owner.

BRP reserves the right to improve or modify products from time to time without assuming any obligation to modify products previously manufactured.

8) TRANSFER

If the ownership of a product is transferred during the warranty coverage period, this limited warranty, subject to its terms and conditions, will NOT be transferred to the new owner.

9) CONSUMER ASSISTANCE

In the event of a controversy or a dispute in connection with this limited warranty, BRP suggests that you try to resolve the issue at the BRP Distributor/Dealer level. We recommend discussing the issue with the authorized BRP Distributor/Dealer's service manager or owner.

If the matter still remains unresolved, contact BRP by filling out the customer contact form at www.brp.com or contact BRP by mail at one of the addresses listed under the [Contact Us](#) section of this guide.

BRP LIMITED WARRANTY FOR THE EUROPEAN ECONOMIC AND THE COMMONWEALTH OF THE INDEPENDENT STATES (CIS) AREAS AND TURKEY: 2025 CAN-AM® ELECTRIC MOTORCYCLES

1) SCOPE OF THE LIMITED WARRANTY

Bombardier Recreational Products Inc. (“**BRP**”) warrants its 2025 Can-Am electric motorcycles (the “**Product**”) and its high-voltage batteries sold by distributors or dealers authorized by BRP to distribute the Product in member states of the European Economic Area (which is comprised of the states of the European Union plus the United Kingdom, Norway, Iceland and Liechtenstein) (“**EEA**”), member states of the Commonwealth of the Independent States (including Ukraine and Turkmenistan) (“**CIS**”) and Turkey (“**BRP Distributor/Dealer**”) from defects in material or workmanship for the period and under the conditions described below.

This limited warranty will become null and void if:

1. The Product was used for racing or any other competitive activity, at any point, even by a previous owner;
2. The Product has been altered or modified in such a way so as to adversely affect its operation, performance or durability, or has been altered or modified to change its intended use;
3. The Product has been altered or modified in such a way so as to adversely affect the high-voltage battery operation, performance or durability;
4. The Product’s high-voltage battery has been used as a stationary power source.

The on-board charger, inverter, and e-motor are covered under the vehicle’s limited warranty period against defects in material or workmanship.

Non-factory installed parts and accessories are not covered under this limited warranty. Please refer to the applicable parts and accessories limited warranty text.

2) LIMITATIONS OF LIABILITY

TO THE EXTENT PERMITTED BY LAW, THIS WARRANTY IS EXPRESSLY GIVEN AND ACCEPTED IN LIEU OF ANY AND ALL OTHER WARRANTIES, EXPRESSED OR IMPLIED, INCLUDING WITHOUT LIMITATION ANY WARRANTY OF MERCHANTABILITY OR FITNESS FOR A PARTICULAR PURPOSE. TO THE EXTENT THAT THEY CANNOT BE DISCLAIMED, THE IMPLIED WARRANTIES ARE LIMITED IN DURATION TO THE LIFE OF THE EXPRESS WARRANTY. INCIDENTAL AND CONSEQUENTIAL DAMAGES ARE EXCLUDED FROM COVERAGE UNDER THIS WARRANTY. SOME JURISDICTIONS DO NOT ALLOW FOR THE DISCLAIMERS, LIMITATIONS AND EXCLUSIONS IDENTIFIED ABOVE. AS A RESULT, THEY MAY NOT APPLY TO YOU. THIS WARRANTY GIVES YOU SPECIFIC RIGHTS, AND YOU MAY ALSO HAVE OTHER LEGAL RIGHTS WHICH MAY VARY FROM COUNTRY TO COUNTRY. BRP SHALL NOT BE HELD LIABLE IF PRODUCTS OR WARRANTY PARTS ARE NOT AVAILABLE IN YOUR COUNTRY FOR REASONS OUTSIDE OF BRP'S CONTROL.

For Products purchased in France, refer to the France specific section below.

Neither the BRP Distributor/Dealer nor any other person has been authorized to make any affirmation, representation or warranty regarding the Product and/or its high-voltage battery, other than those contained in this limited warranty, and if made, shall not be enforceable against BRP.

BRP reserves the right to modify this limited warranty at any time, being understood that such modification will not alter the warranty conditions applicable to the products and/or its high-voltage batteries sold while this warranty is in effect.

3) EXCLUSIONS – ARE NOT WARRANTED

This warranty does not cover damage or failures resulting from or caused by:

- Attempting to modify the on-board charger, inverter and/or e-motor, to gain faster charge times or increase the original power output will void the warranty.
- Opening any of the high voltage components such as high voltage battery, on-board charger, inverter and e-motor.
- Improper towing or vehicle recovery from a depleted high voltage battery or other failure may damage the e-motor or other high voltage components. Failure to follow the recommended towing and/or recovery method prescribed in this manual will void the warranty.

The following are not warranted under any circumstances:

- Normal wear and tear;
- Routine maintenance items, tune ups, adjustments;
- Damage resulting from removal of parts, improper repairs, service, maintenance, modifications or use of parts or accessories not manufactured or approved by BRP or resulting from repairs done by a person that is not an authorized servicing BRP Distributor/Dealer;
- Damage caused by abuse, abnormal use, neglect or operation of the Product in a manner inconsistent with the recommended operation described in the Product's Operator's Guide;
- Damage resulting from accident, submersion, fire, theft, vandalism or any act of God;
- Operation with chemicals, oils or lubricants which are not suitable for use with the product (see the Operator's Guide);
- Damages from rust, corrosion or exposure to the elements;
- Damage resulting from water or snow ingestion;
- Incidental or consequential damages, or damages of any kind including without limitation towing, storage, telephone, rental, taxi, inconvenience, insurance coverage, loan payments, loss of time, loss of income;
- Damage resulting from corrosion from road salts, battery acid, environmental influences or treatment contrary to the Operator's Guide;
- Damages related to the appearance of the Product, including without limitation scratches, dents, fading, flaking, peeling and damages to seat cover material;
- Damage resulting from the installation of parts with specifications that differ from the original Product parts, such as, without limitation, different tires, wheels or brakes.
- Damage or failures due to the installation of non-BRP accessories to the electrical systems of the Can-Am motorcycle.
- Damage caused by failure to provide proper maintenance and/or storage, as described in the Operator's Guide. Ambient temperatures above 40 °C (104 °F) or below —20 °C (-4 °F) may damage the high-voltage battery and void the warranty;
- Damage caused by exposing the high voltage battery to contact with a direct flame;
- Physical damage to the high voltage battery or intentional attempt to reduce the life of the high voltage battery;

- Damage to internal components resulting from disassembly, opening the high-voltage battery enclosure is strictly forbidden;
- Damage resulting from incorrect charging procedures or incompatible charging devices;
- Damage to vehicle's components resulting from a complete discharge of the high-voltage battery;
- Consequential damage caused by the failure to repair an existing problem;
- Damage resulting from failure to install a software update;
- Loss of battery capacity due to or resulting from gradual capacity loss.⁽¹⁾

⁽¹⁾Any capacity/range reduction-based claim must be confirmed by and approved by BRP to be eligible for coverage.

4) WARRANTY COVERAGE PERIOD

The vehicle limited warranty will be in effect from (1) the date of delivery to the first retail consumer, or (2) the date the Product is first put into use, whichever occurs first and for the applicable period below:

1. **TWENTY-FOUR (24) consecutive months**, for private use and **TWELVE (12) consecutive months**, for commercial use owners, except for the items covered in points (2) to (3) below.
2. For the tires, **SIX (6) CONSECUTIVE MONTHS** or until tires are worn to the last three thirty-seconds of an inch (3/32") (2.38 millimeters) for the front tires and the last five thirty-seconds of an inch (5/32") (3.97 millimeters) for the rear tire, whichever occurs first.
3. The high-voltage battery limited warranty will be in effect for **SIXTY (60) consecutive months**, or **fifty thousand kilometers (50,000 km) or (31,250 mi)**, whichever occurs first, **only** if the high-voltage battery state of health (SOH) is equal or greater than (\geq) seventy percent (70%) of initial capacity.

The repair or replacement of parts or the performance of service under this warranty does not extend the life of this warranty beyond its original expiration date. Loss of battery capacity resulting from gradual capacity loss is NOT covered under this warranty beyond the terms and limit specified above.

5) FOR PRODUCTS SOLD IN FRANCE ONLY

The seller shall deliver goods that are complying with the contract and shall be responsible for defects existing upon delivery. The seller shall also be responsible for defects resulting from packaging, assembling instructions or the installation when it is its responsibility per the contract or if accomplished under its responsibility. To be compliant with the contract, the good shall:

1. Be fit for normal use for goods similar thereto and, if applicable:
 - Correspond to the description provided by the seller and have the qualities presented to the buyer though sample or model;
 - Have the qualities that a buyer may legitimately expect considering the public declarations of the seller, the manufacturer of its representative, including in advertising or labeling; or
2. Have the characteristics mutually agreed upon as between the parties or be fit for the specific use intended by the buyer and brought to the attention of the seller and which were accepted by the seller.

The action for failure to comply is prescribed after two years after delivery of the goods. The seller is responsible for the warranty for hidden defects of the good sold if such hidden defects are rendering the good unfit for the intended use, or if they diminish its use in such a way that the buyer would not have acquired the good or would have given a lesser price, had he known. The action for such hidden defects shall be taken by the buyer within 2 years of the discovery of the defect.

6) CONDITIONS REQUIRED FOR WARRANTY COVERAGE

This warranty coverage is available **only** if each of the following conditions has been fulfilled:

- The Product must be purchased as new and unused by its first owner from a BRP Distributor/Dealer authorized to distribute the Product in the country, or in the case of the EEA union of countries, in which the sale occurred ;
- The BRP specified pre-delivery inspection process must be completed and documented by the purchaser and the authorized BRP Distributor/Dealer and signed by the purchaser;
- The Product must have undergone proper registration by an authorized BRP Distributor/Dealer;
- The Product must be purchased in the country in which the purchaser resides; and
- Routine maintenance outlined in the Operator's Guide must be timely performed in order to maintain warranty coverage. BRP reserves the right to make warranty coverage contingent upon proof of proper maintenance.

BRP will not honor this limited warranty to any use owner if one of the preceding conditions has not been met. Such limitations are necessary in order to allow BRP to preserve both the safety of its products, and also that of its consumers and the general public.

7) WHAT TO DO TO OBTAIN WARRANTY COVERAGE

The customer and/or commercial operator must cease using the Product upon the appearance of an anomaly, notify a servicing BRP Distributor/Dealer or BRP directly within three (3) days of the appearance of the anomaly and provide the Dealer with reasonable access to the Product and reasonable opportunity to repair it.

All parts replaced under this limited warranty become the property of BRP.

8) WHAT BRP WILL DO

BRP's obligations under this warranty are limited to, at its sole discretion, repairing parts found defective under normal use, maintenance and service, or replacing such parts without charge for parts and labor, at any authorized BRP dealer during the warranty coverage period under the conditions described herein. No claim of breach of warranty shall be cause for cancellation or rescission of the sale of the Product to the owner.

BRP reserves the right to improve or modify products from time to time without assuming any obligation to modify products previously manufactured.

9) TRANSFER

If the ownership of a product is transferred during the warranty coverage period, this limited warranty, subject to its terms and conditions, will NOT be transferred to the new owner.

10) CONSUMER ASSISTANCE

In the event of a controversy or a dispute in connection with this limited warranty, BRP suggests that you try to resolve the issue at the BRP Distributor/Dealer level. We recommend discussing the issue with the authorized BRP Distributor/Dealer's service manager or owner.

If the matter still remains unresolved, contact BRP by filling out the customer contact form at www.brp.com or contact BRP by mail at one of the addresses listed under the [Contact Us](#) section of this guide.

9 CUSTOMER INFORMATION - TABLE OF CONTENTS

DATA PRIVACY INFORMATION	9-2
CONTACT US.....	9-5
CHANGE OF ADDRESS/OWNERSHIP	9-6

DATA PRIVACY INFORMATION

Bombardier Recreational Products Inc., its affiliates and subsidiaries (“BRP”) are committed to protecting your privacy and support a general policy of openness about how we collect, use and disclose your personal information in the course of managing our relationship with you.

More details can be found by visiting BRP’s Privacy Policy at:

<https://brp.com/en/privacy-policy.html> or by scanning the QR Code below.

Please be assured that we have appropriate security measures in place to ensure that your personal information is protected against loss and unauthorized access.

Your personal information that may be collected by BRP, directly from you or from authorized dealers or authorized third parties, includes:

- **Contact, Demographic & Registration Information** (e.g., name, full address, phone number, email, gender, ownership history, language of communication)
- **Vehicle Information** (e.g., serial number, purchase and delivery date, unit usage, vehicle location and movements)
- **Third Party Information** (e.g., information received from BRP partners, joint-marketing activities information, social media)
- **Technological Information** (e.g., IP address, type of device, operating system, browser type, webpages you view, cookies and similar technologies when you use BRP or dealers’ websites or mobile application)
- **Interaction with BRP Information** (e.g., information collected when you call BRP’s in-house sales representatives, buy items on a BRP website, sign up for BRP emails, participate in BRP-sponsored contests and sweepstakes or attend BRP-sponsored events)
- **Transactional Information** (e.g., information necessary to handle returns, payment information when you purchase our products or services through our websites or mobile applications and other issues related to your purchase of BRP products)

This information may be used and processed for the following purposes:

- Safety & Security
- Customer Support for Sales & After Sales (e.g., complete or follow up with you about your purchase or maintenance)
- Registration & Warranty
- Communication (e.g., sending you a BRP satisfaction survey)
- Online Behavioural Advertising, Profiling and Location-Based Services (e.g., offer customized experience)
- Compliance & Dispute Resolution
- Marketing & Advertising
- Assistance (e.g., help with any delivery issues, handle returns, and other issues related to your purchase of BRP products).

We also may use personal information to generate aggregated or statistical data that no longer identifies you personally.

Your personal information may be disclosed to the following: BRP, BRP's authorized dealerships, distributors, service providers, advertising & market research partners and other authorized third parties.

We may receive information about you from diverse sources, including third parties, such as BRP's authorized dealerships and partners, with whom we offer services or engage in joint-marketing activities. We may also receive information about you from social media platforms such as Facebook and Twitter when you interact with us on those platforms.

Depending on the circumstances, your personal information may be communicated outside the region where you reside. Your personal information is retained only for as long as necessary for the purpose for which we obtained it and according to our retention policies.

To exercise your data privacy rights (e.g. right of access, right of rectification), to withdraw your consent in order to be removed from the address list for marketing purposes or for the satisfaction survey or for general data privacy questions, please contact BRP's Data Protection Officer at **privacyofficer@brp.com** or by mail at:
BRP Legal Service, 726 St-Joseph, Valcourt, Quebec, Canada, J0E 2L0.

When BRP processes your personal information, they do so in compliance with its Privacy Policy available at: <https://www.brp.com/en/privacy-policy.html> or by using the following QR Code.



CONTACT US

www.brp.com

Asia Pacific

BRP Asia

107D and 107E, 17/F, Tower 1,
Grand Century Place, Mongkok,
Kowloon, Hong Kong

Australia

Level 26
477 Pitt Street
Sydney, NSW 2020

China

上海市徐汇区衡山路10号6号楼301
Rm 301, Building 6,
No.10 Heng Shan Rd,
Shanghai, China

Japan

21F Shinagawa East One Tower
2-16-1 Konan, Minato-ku-ku,
Tokyo 108-0075

New Zealand

Suite 1.6, 2-8 Osborne Street,
Newmarket, Auckland 2013

Latin America

Brazil

Av. James Clerck Maxwell, 230
Campinas, Sao Paulo
CEP 13069-380

Mexico

Av. Ferrocarril 202
Parque Industrial Querétaro
Santo Rosa Jauregui, Querétaro
C.P. 76220

Europe, Middle East and Africa

Belgium

Oktrooiplein 1
9000 Gent

Czech Republic

Stefanikova 43a
Prague 5
150 00

Germany

Alte Papierfabrik 16
D-40699 Erkrath

Finland

Isoaavantie 7
PL 8040
96101 Rovaniemi

France

Arteparc Bâtiment B
Route de la côte d'Azur,
13 590 Meyreuil

Norway

Ingvald Ystgaardsvei 15
N-7484 Trondheim
Salg, marketing, ettermarked

Sweden

Spinnvägen 15
903 61 Umeå
Sweden 90821

Switzerland

Avenue d'Ouchy 4-6
1006 Lausanne

North America

Canada

3200A, rue King Ouest,
Suite 300
Sherbrooke (Québec) J1L 1C9

United States of America

10101 Science Drive
Sturtevant, Wisconsin
53177

CHANGE OF ADDRESS/OWNERSHIP

If your address has changed or if you are the new owner of the motorcycle, be sure to notify BRP by either:

- Notifying an authorized BRP Can Am dealer or distributor.
- **North America only:** calling 1-888-272-9222.
- Mailing one of the change of address cards on the following pages to one of the BRP addresses indicated in the [Contact Us, page 9-5](#) section of this guide.

In case of change of ownership, please include a proof that the former owner agreed to the transfer.

Notifying BRP, even after the expiration of the limited warranty, is very important as it enables BRP to reach the motorcycle owner if necessary, like when safety recalls are initiated. It is the owner's responsibility to notify BRP.

STOLEN UNITS: If your personal motorcycle is stolen, you should notify BRP or an authorized BRP Can Am dealer. We will ask you to provide your name, address, phone number, the vehicle identification number and the date it was stolen.

This page is
intentionally blank

CHANGE OF ADDRESS CHANGE OF OWNERSHIP 

VEHICLE IDENTIFICATION NUMBER

Model Number	Vehicle Identification Number (V.I.N.)
--------------	--

OLD ADDRESS OR PREVIOUS OWNER: _____

NAME _____

NO. _____ STREET _____ APT _____

CITY _____ STATE/PROVINCE _____ ZIP/POSTAL CODE _____

COUNTRY _____ TELEPHONE _____

NEW ADDRESS OR NEW OWNER: _____

NAME _____

NO. _____ STREET _____ APT _____

CITY _____ STATE/PROVINCE _____ ZIP/POSTAL CODE _____

COUNTRY _____ TELEPHONE _____

E-MAIL ADDRESS _____

CHANGE OF ADDRESS CHANGE OF OWNERSHIP 

VEHICLE IDENTIFICATION NUMBER

Model Number	Vehicle Identification Number (V.I.N.)
--------------	--

OLD ADDRESS OR PREVIOUS OWNER: _____

NAME _____

NO. _____ STREET _____ APT _____

CITY _____ STATE/PROVINCE _____ ZIP/POSTAL CODE _____

COUNTRY _____ TELEPHONE _____

NEW ADDRESS OR NEW OWNER: _____

NAME _____

NO. _____ STREET _____ APT _____

CITY _____ STATE/PROVINCE _____ ZIP/POSTAL CODE _____

COUNTRY _____ TELEPHONE _____

E-MAIL ADDRESS _____

This page is
intentionally blank

CHANGE OF ADDRESS CHANGE OF OWNERSHIP 

VEHICLE IDENTIFICATION NUMBER

Model Number	Vehicle Identification Number (V.I.N.)
--------------	--

OLD ADDRESS OR PREVIOUS OWNER: _____

NAME _____

NO. _____ STREET _____ APT _____

CITY _____ STATE/PROVINCE _____ ZIP/POSTAL CODE _____

COUNTRY _____ TELEPHONE _____

NEW ADDRESS OR NEW OWNER: _____

NAME _____

NO. _____ STREET _____ APT _____

CITY _____ STATE/PROVINCE _____ ZIP/POSTAL CODE _____

COUNTRY _____ TELEPHONE _____

E-MAIL ADDRESS _____

CHANGE OF ADDRESS CHANGE OF OWNERSHIP 

VEHICLE IDENTIFICATION NUMBER

Model Number	Vehicle Identification Number (V.I.N.)
--------------	--

OLD ADDRESS OR PREVIOUS OWNER: _____

NAME _____

NO. _____ STREET _____ APT _____

CITY _____ STATE/PROVINCE _____ ZIP/POSTAL CODE _____

COUNTRY _____ TELEPHONE _____

NEW ADDRESS OR NEW OWNER: _____

NAME _____

NO. _____ STREET _____ APT _____

CITY _____ STATE/PROVINCE _____ ZIP/POSTAL CODE _____

COUNTRY _____ TELEPHONE _____

E-MAIL ADDRESS _____

This page is
intentionally blank

CHANGE OF ADDRESS CHANGE OF OWNERSHIP 

VEHICLE IDENTIFICATION NUMBER

Model Number	Vehicle Identification Number (V.I.N.)
--------------	--

OLD ADDRESS OR PREVIOUS OWNER: _____

NAME _____

NO. _____ STREET _____ APT _____

CITY _____ STATE/PROVINCE _____ ZIP/POSTAL CODE _____

COUNTRY _____ TELEPHONE _____

NEW ADDRESS OR NEW OWNER: _____

NAME _____

NO. _____ STREET _____ APT _____

CITY _____ STATE/PROVINCE _____ ZIP/POSTAL CODE _____

COUNTRY _____ TELEPHONE _____

E-MAIL ADDRESS _____

CHANGE OF ADDRESS CHANGE OF OWNERSHIP 

VEHICLE IDENTIFICATION NUMBER

Model Number	Vehicle Identification Number (V.I.N.)
--------------	--

OLD ADDRESS OR PREVIOUS OWNER: _____

NAME _____

NO. _____ STREET _____ APT _____

CITY _____ STATE/PROVINCE _____ ZIP/POSTAL CODE _____

COUNTRY _____ TELEPHONE _____

NEW ADDRESS OR NEW OWNER: _____

NAME _____

NO. _____ STREET _____ APT _____

CITY _____ STATE/PROVINCE _____ ZIP/POSTAL CODE _____

COUNTRY _____ TELEPHONE _____

E-MAIL ADDRESS _____

This page is
intentionally blank

Model No. _____
VEHICLE
IDENTIFICATION NUMBER (V.I.N.) _____
HIGH-VOLTAGE BATTERY
SERIAL NUMBER _____

Owner: _____
NAME

No. STREET APT

CITY STATE/PROVINCE ZIP/POSTAL CODE

Purchase Date _____
YEAR MONTH DAY

Warranty Expiry Date _____
YEAR MONTH DAY

To be completed by the dealer at the time of the sale.

DEALER IMPRINT AREA

In Canada, products are distributed and serviced by Bombardier Recreational Products Inc. (BRP).

In the USA, products are distributed and serviced by BRP US Inc.

In the European Economic Area (which is comprised of the member states of the European Union plus the United Kingdom, Norway, Iceland and Liechtenstein), the Commonwealth of the Independent States (including Ukraine and Turkmenistan) and Turkey, products are distributed and serviced by BRP European Distribution S.A. and other affiliates or subsidiaries of BRP.

For all other countries, products are distributed and serviced by Bombardier Recreational Products Inc. (BRP) or its affiliates.

™® Trademarks of BRP or its affiliates.

This is a non-exhaustive list of trademarks that are the property of Bombardier Recreational Products Inc. or its affiliates.

Trademarks may not be registered in every jurisdictions.

Can-Am®
ROTAX E-POWER™

LinQ®
XPS®

Origin®

All rights reserved. No parts of this Manual may be reproduced in any form without the prior written permission of Bombardier Recreational Products Inc.

©2024 BOMBARDIER RECREATIONAL PRODUCTS INC.

www.brp.com



 **WARNING**

Disregarding any of the safety precautions and instructions contained in the operators's guide and on product safety labels could cause injury including the possibility of death.

219002337

