

ski-doo®



MXZ 600RS

OPERATOR'S GUIDE

Includes Safety, Use and Maintenance
Information

2007

⚠ WARNING

Read this guide thoroughly. It contains important safety information.
Minimum recommended operators age: 16 years old.
Keep this operator's guide with the vehicle at all times.

520003294

**Original
Instructions**

 **WARNING**

This vehicle may exceed the performance of other vehicles you may have ridden in the past. Take time to familiarize yourself with your new vehicle.

CALIFORNIA PROPOSITION 65 WARNING

 **WARNING**

Operating, servicing and maintaining an off-road vehicle can expose you to chemicals including engine exhaust, carbon monoxide, phthalates, and lead, which are known to the State of California to cause cancer and birth defects or other reproductive harm. To minimize exposure, avoid breathing exhaust, do not idle the engine except as necessary, service your vehicle in a well-ventilated area and wear gloves or wash your hands frequently when servicing your vehicle. For more information go to www.p65warnings.ca.gov/products/passenger-vehicle.

™® Trademarks of BRP or its affiliates.

This is a non-exhaustive list of trademarks that are the property of Bombardier Recreational Products Inc. or its affiliates trademarks may not be registered in every jurisdictions :

D.E.S.S.™

E-TEC®

HPG™

MXZ®

RAVE®

RER™

ROTAX®

SKI-DOO®

XPS®

LinQ®

The KYB Pro series is a registered mark of KYB America LLC.

All rights reserved. No parts of this Manual may be reproduced in any form without the prior written permission of Bombardier Recreational Products Inc.

©Bombardier Recreational Products Inc. (BRP) 2024

Deutsch	Dieses Handbuch ist möglicherweise in Ihrer Landessprache verfügbar. Bitte wenden Sie sich an Ihren Händler oder besuchen Sie: www.operatorsguides.brp.com
English	This guide may be available in your language. Check with your dealer or go to: www.operatorsguides.brp.com
Español	Es posible que este manual esté disponible en su idioma. Consulte a su distribuidor o visite: www.operatorsguides.brp.com
Français	Ce guide peut être disponible dans votre langue. Vérifier avec votre concessionnaire ou aller à: www.operatorsguides.brp.com
Italiano	Questa guida potrebbe essere disponibile nella propria lingua. Contattare il concessionario o consultare: www.operatorsguides.brp.com
中文	本手册可能有您的语种的翻译版本。请向经销商询问，或者登录 www.operatorsguides.brp.com 查询。
日本語	このガイドは、言語によって翻訳版が用意されています。ディーラーに問い合わせるか、次のアドレスでご確認ください： www.operatorsguides.brp.com
Nederlands	Deze handleiding kan beschikbaar zijn in uw taal. Vraag het aan uw dealer of ga naar: www.operatorsguides.brp.com
Norsk	Denne boken kan finnes tilgjengelig på ditt eget språk. Kontakt din forhandler eller gå til: www.operatorsguides.brp.com
Português	Este manual pode estar disponível em seu idioma. Fale com sua concessionária ou visite o site: www.operatorsguides.brp.com
Русский	Воспользуйтесь руководством на вашем языке. Узнайте о его наличии у дилера или на странице по адресу www.operatorsguides.brp.com
Suomi	Käyttöohjekirja voi olla saatavissa omalla kielelläsi. Tarkista jälleenmyyjältä tai käy osoitteessa: www.operatorsguides.brp.com
Svenska	Denna bok kan finnas tillgänglig på ditt språk. Kontakta din återförsäljare eller gå till: www.operatorsguides.brp.com

Model	Package	Engine
MXZ	600RS	600RS E-TEC

In Canada, products are distributed and serviced by Bombardier Recreational Products Inc. (BRP).

In the USA, products are distributed and serviced by BRP US Inc.

In the European Economic Area (which is comprised of the member states of the European Union plus the United Kingdom, Norway, Iceland and Liechtenstein), the Commonwealth of the Independent States (including Ukraine and Turkmenistan) and Turkey, products

are distributed and serviced by BRP European Distribution S.A. and other affiliates or subsidiaries of BRP.

For all other countries, products are distributed and serviced by Bombardier Recreational Products Inc. (BRP) or its affiliates.

TABLE OF CONTENTS

GENERAL INFORMATION

GENERAL INFORMATION	8
Know Before you Go	8
Safety Messages	8
About this Operator's Guide	9

SAFETY INFORMATION

BEFORE YOU GO	12
Operating Age and Ability	12
Drugs and Alcohol	12
Avalanche Safety Training Courses	12
Protective Gear	13
Required Equipment	13
GET FAMILIAR WITH THE SNOWMOBILE	15
Track Propulsion System	15
Steering	15
Tether Cord	16
Braking	16
Parking Brake	16
Towing Another Snowmobile	16
Accessories and Modifications	17
Traction Enhancing Products	18
RIDE SAFELY	22
Rider Position (Forward Operation)	22
Rider Position (Reverse Operation)	24
Riding with Passenger(s)	24
Riding Alone	25
Riding in a Group	25
Avoiding Collisions	26
Riding Behaviors	26
Speeding	27
Moving Parts	27
Know Terrain and Riding Variations	27
Respect of the Wildlife	31
Carbon Monoxide (CO) Poisoning	31
Gasoline Fires and Other Hazards	32
Burns from Hot Parts	32
PRACTICE EXERCISES	33
Where to Practice Exercises	33
Exercises to Practice	33
FUELING	36
Fueling Procedure	36
VEHICLE TRANSPORTATION	37
IMPORTANT ON-PRODUCT LABELS (CANADA/UNITED STATES)	38
Vehicle Safety Labels	38

TABLE OF CONTENTS

Technical Information Labels	52
IMPORTANT ON-PRODUCT LABELS (ALL COUNTRIES EXCEPT CANADA/UNITED STATES)	57
Vehicle Safety Labels	57
Technical Information Labels	73
PRE-RIDE INSPECTION	78
Before Starting the Engine	78
After Engine is Started	78
Pre-Ride Check List	79
REPORTING SAFETY DEFECTS	81

VEHICLE INFORMATION

PRIMARY CONTROLS	84
Handlebar	84
Throttle Lever	84
Emergency Engine Stop Switch	85
Brake Lever	86
Parking Brake Lever	87
Engine Cut-off Switch	89
SECONDARY CONTROLS	91
Rewind Starter Handle	91
Exhaust Tuned Pipe Preheat Button	92
Headlights Dimmer Button	92
Heated Grips and Heated Throttle Lever Switch	93
BODY	95
Front and Rear Bumpers	95
Upper Body Module	96
Side Panels	99
EQUIPMENT	102
Drive Belt Guard	102
COMPACT DIGITAL DISPLAY	105
Display Features	106
FUEL AND OIL	115
Fuel Requirements	115
Pre-Mix Oil	116
Fueling Procedure	117
BREAK-IN PERIOD	119
Operation During Break-In	119
BASIC PROCEDURES	121
Engine Starting Procedure	121
Vehicle Warm-Up	121
Shutting Off the Engine	122
RIDING CONDITIONS AND YOUR SNOWMOBILE	124
Altitude	124
Temperature	124
Hard Packed Snow	124

TUNE YOUR RIDE 126
 Front Suspension Adjustments 126
 Rear Suspension Adjustments 130
 Adjustment Tips According to Vehicle Behavior 146

MAINTENANCE

MAINTENANCE SCHEDULE 150
MAINTENANCE PROCEDURES 152
 Engine Coolant 152
 Exhaust System 153
 Spark Plugs 154
 Brake Fluid 159
 Chaincase Oil 164
 Drive Chain 168
 Drive Belt 169
 Drive Pulley 173
 Track 177
 Suspension 185
 Skis 187
 Fuses 187
 Headlights 188
VEHICLE CARE 191
 Post-Operation Care 191
 Vehicle Cleaning and Protection 191
STORAGE 192
MAINTENANCE RECORDS 193

TECHNICAL INFORMATION

VEHICLE IDENTIFICATION 202
 Vehicle Description Decal 202
 Identification Numbers 202
COMPLIANCE LABELS 204
 EPA Exemption Label 204
 SSCC Label 205
 Regulation (EU) 2016/1628 applicable for Non-Road Mobile
 Machineries 205
EU DECLARATION OF CONFORMITY 207
UK DECLARATION OF CONFORMITY 208
EAC DECLARATION OF CONFORMITY 209
BRP RF DESS POST GEN2 (MOWP) 210
 USA and Canada 210
 Mexico 211
 Brazil 211
 Japan 211
 Europe 211

RADIO FREQUENCY DIGITALLY ENCODED SECURITY SYSTEM (RF D.E.S.S. KEY).....216

TECHNICAL SPECIFICATIONS

ENGINE218
VEHICLE220

TROUBLESHOOTING

TROUBLESHOOTING GUIDELINES.....226
 Troubleshooting.....226
MONITORING SYSTEM229
 Icons, Messages and Beeper Codes229
 Fault Codes232

CUSTOMER INFORMATION

DATA PRIVACY INFORMATION.....238
CONTACT US.....240
 Asia Pacific240
 Europe, Middle East and Africa240
 Latin America.....241
 North America.....241
CHANGE OF ADDRESS/OWNERSHIP.....242

GENERAL INFORMATION

GENERAL INFORMATION

Know Before you Go

To learn how to reduce the risk for you, your passenger or bystanders being injured or killed, read the following sections before you operate the vehicle:

- *Safety Information*
- *Vehicle Information.*

Also read all safety labels on your snowmobile and watch attentively the safety video located at:

Or, use the following QR code.



Safety Messages

This operator's guide utilizes the following symbols and words to emphasize particular information:

The safety alert symbol  indicates a potential injury hazard.

WARNING

Indicates a potential hazard which, if not avoided, could result in serious injury or death.

CAUTION

Indicates a hazard situation which, if not avoided, could result in minor or moderate injury.

NOTICE

Indicates an instruction which, if not followed, could severely damage vehicle components or other property.

About this Operator's Guide

This operator's guide has been prepared to acquaint the owner, operator and passenger with this snowmobile and its various controls, maintenance and safe riding instructions.

The following terminology in regards to operator, passenger and vehicle configuration is used as follows throughout this guide:

- **Operator:** refers to the person being behind the controls and driving the snowmobile.
- **Passenger:** refers to a person sitting behind the operator.
- **1-UP:** refers to a model designed for an operator only.
- **2-UP:** refers to a model designed to accommodate **one** passenger.

Keep this operator's guide in the vehicle as you can refer to it for the operation, instructing others, maintenance and troubleshooting.

Note that this guide is available in several languages. In the event of any discrepancy, the English version shall prevail.

If you want to view and/or print an extra copy of your operator's guide, simply visit the following website:

www.operatorsguides.brp.com

The information contained in this document is correct at the time of publication. BRP, however, maintains a policy of continuous improvement of its products without imposing upon itself any obligation to install them on products previously manufactured. Due to late changes, some differences between the manufactured product and the descriptions and/or specifications in this guide may occur. BRP reserves the right at any time to discontinue or change specifications, designs, features, models or equipment without incurring any obligation upon itself.

This operator's guide should remain with the vehicle when it's sold.

This page is intentionally blank

SAFETY INFORMATION

BEFORE YOU GO

WARNING

Disregarding any of the safety precautions and instructions contained in this section could cause injury including the possibility of death.

Operating Age and Ability

Operators must be qualified. Make sure the operator is 16 or older. Your state (or province) may have additional requirements. Laws regarding the minimum age and licensing requirements vary from one jurisdiction to another. Be sure to contact the local authorities for information regarding the legal operation of a snowmobile in the intended jurisdiction of use. BRP highly recommends that you take a safety riding course. Basic training is required for the safe operation of any snowmobile.

Operation of this snowmobile with a disability that impairs vision, reaction time, judgment, or operation of the controls is not recommended. The safe use of your snowmobile depends on many conditions such as visibility, speed, weather, environment, traffic, vehicle condition and the condition of the operator. The performance of some snowmobiles may significantly exceed that of other snowmobiles you have operated. Therefore, use by novice or inexperienced operators is not recommended.

Each passenger must be able to simultaneously place both feet firmly flat against each footboard when properly seated.

Drugs and Alcohol

Never ride after consuming alcohol or drugs. Riding on a snowmobile requires the operator and passenger (s) to be sober, attentive and alert. The use of drugs and alcohol, singly or in combination, decreases reaction time, impedes judgment, impairs vision, and inhibits your ability to safely ride on a snowmobile.

Avalanche Safety Training Courses

We recommend that all mountain riders take a local avalanche safety training course to become more familiar with snow conditions and learn how to properly use their equipment. Here are some web sites that can help you finding important information:

- - US: www.avalanche.org
- - Europe: www.avalanches.org
- - Canada: www.avalanche.ca

Protective Gear

Proper snowmobile clothing should be worn by all riders. It should be comfortable and not too tight. Always check the weather forecast before going on a ride. Dress for the coldest weather expected. Thermal underwear next to the skin also provides a good insulation.

Always wear an approved helmet at all times for safety and comfort. They provide both warmth and reduce injury. A stocking type cap, balaclava and face mask should always be carried or worn. Goggles or a face shield that attach to the helmet are indispensable.

Hands should be protected by a pair of snowmobile gloves or mitts which have sufficient insulation and allow use of thumbs and fingers for operation of controls.

Rubber bottom boots with either a nylon or a leather top, with removable felt liners are best suited for snowmobiling.

You should keep yourself as dry as possible when snowmobiling. When you come indoors, take your snowmobile suit and boots off and make certain they dry properly.

Do not wear a long scarf or loose apparels that could get caught in moving parts.

Carry colored lens goggles.

Required Equipment

As the owner of the snowmobile, you are responsible for ensuring that all required safety equipment is aboard. Check your local regulations about requirements.

First aid kit	Provided tool kit
Mobile phone	Knife
Spare spark plugs	Flashlight
Adhesive tape (duct tape)	Trail map
Spare drive belt	Snack
Probe*	Shovel*

Avalanche beacon*	-
*When riding in an area with avalanche risk	

GET FAMILIAR WITH THE SNOWMOBILE

This vehicle may exceed the performance of other vehicles you may have ridden. Take time to familiarize yourself with your new vehicle.

Inexperienced riders may overlook risks and be surprised by vehicle's specific behavior and terrain conditions. Ride slowly. Excessive speed and reckless driving can kill.

Make sure you read and understand the content of this operator's guide to become completely familiar with the controls and operation of the snowmobile before embarking on your first trip or taking on a passenger(s). If you have not had the opportunity to do so, practice driving solo in a suitable traffic-free area to become accustomed to the feel and response of each control.

It is very important to inform any operator, regardless of his experience, of the handling characteristics of this snowmobile. The snowmobile configuration, such as ski stance, ski type, suspension type, track length, width and type vary from a model to another. The snowmobile handling is greatly influenced by these characteristics.

Track Propulsion System

Your snowmobile features a track propulsion system. The track grips on the snow-covered surface and pushes the snowmobile in the opposite direction of the force applied on the surface. Stay away from the track. Personal injury will result if contact is made with the revolving track.

 **WARNING**

Never stand behind or near a rotating track. Debris could be projected causing severe injuries.

The grip of the track will vary depending on the surface conditions. The grip may be reduced on hard-pack snow or ice. Reduce your speed and allow more space to turn. Refer to the *TRACTION ENHANCING PRODUCTS* subsection of this guide to learn how to balance the grip of the ski vs the grip of the track. If the front and rear of the snowmobile are out of balance due to an incorrect combination of traction enhancing products, the snowmobile may tend to oversteer or understeer, which could lead to a loss of control.

Steering

Skis are used to steer the snowmobile through the handlebar. The performance to steer will vary depending of the grip of the skis on the surface. Steering control ability may be reduced on hard-pack snow, ice or roads. Reduce speed and allow more space to turn. Refer to the *TRACTION ENHANCING PRODUCTS* subsection of this guide to learn how to balance the grip of the ski versus the grip of the track. If

the front and rear of the snowmobile are out of balance due to an incorrect combination of traction enhancing products, the snowmobile may tend to oversteer or understeer, which could lead to a loss of control.

Riding with a passenger or when carrying loads, the steering control will also be reduced. Reduce speed and allow more space to turn.

Tether Cord

Always attach tether cord eyelet to clothing before starting the engine to help ensure the engine stops should the operator fall off.

After riding, always remove the tether cord from the engine cut-off switch to avoid unauthorized use by children or others and to prevent starting in a closed environment (ex: garage).

Braking

Braking performances may vary suddenly under certain conditions. Always remember that the snowmobile braking distance may be affected when riding with a passenger and when loaded with cargo at the rear. Never jam the brake and lock the track. Be sure to use restraint in braking to keep from blocking the track in order to avoid surprises that could lead to a loss of control.

Using studs on the track will give you better braking capacity on packed snow or ice but will have no noticeable effect on soft snow. Refer to *Enhancing Traction Control Products* subsection for track studding application.

Parking Brake

Always engage parking brake before starting the engine. Parking brake should be used whenever snowmobile is parked.

Make sure parking brake is fully disengaged before operating the snowmobile. When you ride the vehicle, brake pads that are caused to drag by a continuous pressure on the lever may cause damage to the brake system and cause loss of braking capacity or fire.

Towing Another Snowmobile

If a snowmobile is disabled and must be towed, in an emergency situation only, a rope can be used

- Remove the drive belt. Refer to *Maintenance Procedures* for more details.
- Attach the rope to the ski legs (spindles), **not** to the skis. If the ski legs are not accessible, attach the rope to the bumper.

- Have someone sit on the towed snowmobile to steer and activate the brake if needed.
- Tow at low speed with extra caution.

NOTICE

Always remove the drive belt of the snowmobile that is to be towed to prevent damage to its belt and drive system.

In some areas, it may be illegal to do so. Check with state or local authorities.

Accessories and Modifications

Any modifications or addition of accessories approved by BRP may affect the handling of your vehicle. It is important to take the time to get familiar with the vehicle once modifications are made to understand how to adapt your driving behavior accordingly.

Avoid installing equipment not specifically approved by BRP for the vehicle and avoid unauthorized modifications. These modifications and equipment have not been tested by BRP and may create hazards. For example, they could:

- Create a loss of control and increase risk of crash
- Cause overheating or short circuits increasing the risk of fire or burn injuries
- Affect the protection features provided by the vehicle
- Affect the behavior of the trailer when the vehicle is transported
- Cause a risk of losing objects on the road when transported.

Your vehicle may also become illegal to ride.

Ask your authorized BRP dealer for suitable available accessories for your vehicle.

For safety reasons, some BRP accessories must be installed by a BRP dealer but if you decide to install the accessory by yourself, when not required to be done by the dealer, it is important to follow all the instructions carefully and, if applicable, understand all the information on how to use the product or for servicing.

If the accessory has been installed on your vehicle by another person than you, BRP strongly recommends you to read the corresponding instruction sheet as there may be more for information on how to use it safely or for the servicing.

The instruction sheets can be found at this address:

- [HTTPS://INSTRUCTIONS.BRP.COM](https://instructions.brp.com)

Traction Enhancing Products

NOTE:

This section is applicable to all snowmobile models that are either equipped with a:

- Factory installed track approved by BRP for special studs installation.
- Factory pre-studded track.

or that can received one of these tracks.

Always refer to your authorized BRP snowmobile dealer to learn more on traction enhancing products and applicability on your snowmobile.

Using traction enhancing products such as, adjustable or more aggressive ski carbide runners and / or track studs on your snowmobile will change its behavior, particularly in terms of maneuverability, acceleration, and braking.

Using traction enhancing products gives a better grip on hard packed snow and ice, but has no noticeable effect in deep snow. For this reason, driving a snowmobile equipped with traction enhancing products requires a certain adaptation period. If your snowmobile is equipped with traction enhancing products, be sure to take plenty of time to get used to the way it handles when turning, accelerating, and braking.

The use of track studs can increase the load and the stress on certain snowmobile components, as well as the vibration level. This can cause premature wear on parts such as belt, brake linings, bearings, chain, chain sprockets, and shorten track life.

Track studs can also cause serious damage to your snowmobile if it is not equipped with the appropriate tunnel protectors.

Check local regulations concerning the use of traction enhancing products on snowmobiles.

Studding an unapproved track or using unapproved studs increase the risk of the track tearing or severing

Installing track studs and tunnel protector(s) requires technical knowledge. To ensure safe and proper installation, BRP recommends to have the studs installed by your dealer.

For maintenance and replacement refer to *Track* in *Maintenance Procedures*.

Maneuverability

Using traction enhancing products such as, more aggressive ski carbide runners and/or studs makes the snowmobile grip the ground better at both the front and at the rear. The use of carbide runners is

therefore required to give the skis a better grip, so that the front and rear of the snowmobile are in balance. While off-the-shelf carbide ski runners are adequate, they don't necessarily give you optimal control, since that depends on your personal preferences, your riding style, and how your suspension is adjusted.

! WARNING

If the front and rear of the snowmobile are out of balance due to an incorrect combination of traction enhancing products, the snowmobile may tend to oversteer or understeer, which could lead to a loss of control.

Oversteering

In certain conditions, using more aggressive ski carbide runners without studs on the rear track could make the snowmobile prone to oversteering, see illustration.

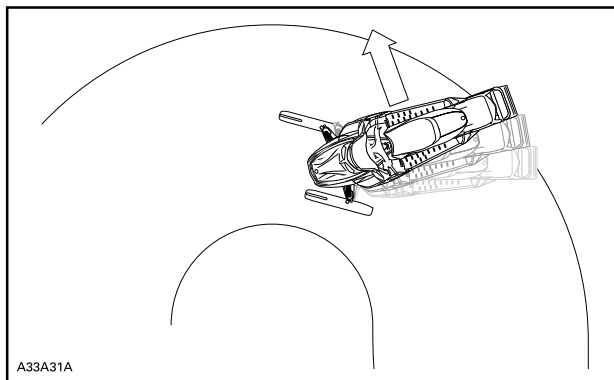

OVERSTEERING

Understeering

In certain conditions, the use of studs on the track could make the snowmobile prone to understeering if the skis are not equipped with more aggressive ski carbide runners, see illustration.

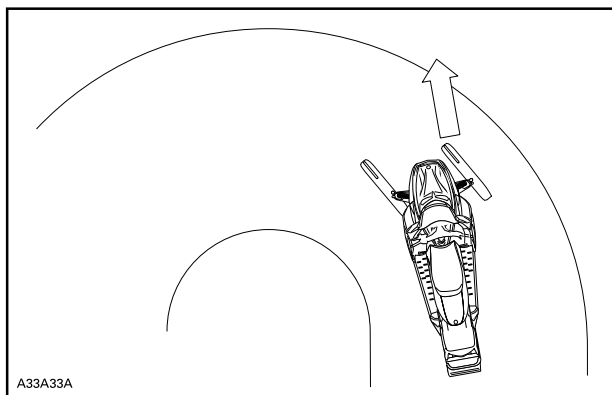

UNDERSTEERING

Controlled Driving

A balanced combination of carbide ski runners and studs on the track ensures adequate control and better handling, see illustration.

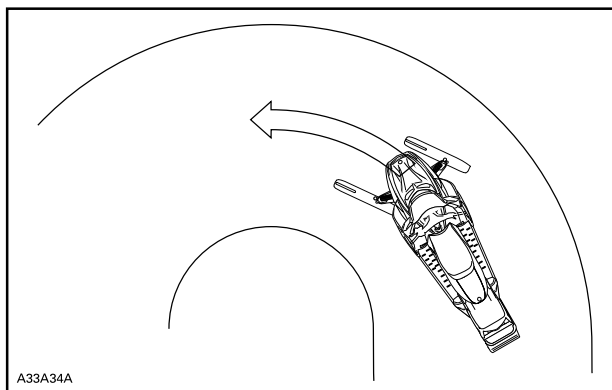

CONTROLLED DRIVING

Acceleration

Using studs on the track will allow your sled to accelerate better on packed snow and ice but will have no noticeable effect on soft snow. This can cause sudden variations in traction under certain conditions.

Always go easy on the throttle and never try to spin the track to make the rear of the snowmobile skid. This could cause debris or ice to be thrown violently backwards, possibly injuring others nearby or on snowmobiles behind you.

Braking

As in the case of acceleration, using studs on the track will give you better braking capacity on packed snow or ice but will have no noticeable effect on soft snow. Braking may thus vary suddenly under certain conditions. Be sure to use restraint in braking to keep from blocking the track in order to avoid surprises that could lead to a loss of control.

RIDE SAFELY

Rider Position (Forward Operation)

Your riding position and balance are the two basic principles of making your snowmobile go where you want it to. When turning on the side of a hill, you and your passenger must be ready to shift body weight to help it turn in the desired direction. Operator and passenger must never attempt this maneuvering by placing feet outside of the vehicle. Experience will teach you how much lean to put into turns at different speeds and how much you will have to lean into a slope to maintain proper balance.

Generally, the riding position for best balance and control is sitting. However, the posting, kneeling or standing positions are also used under certain conditions.



Do not attempt any maneuvers if they are beyond your abilities.

Sitting

Feet on the running boards, body midway back on seat is an ideal position when operating the snowmobile over familiar, smooth terrain. Knees and hips should remain flexible to absorb shocks.



Posting

A semi-sitting position with the body off the seat and the feet under the body in a sort of squatting posture, thus allowing the legs to absorb the shocks when traveling over uneven terrain. Avoid abrupt stops.



Kneeling

This position is achieved by placing one foot firmly on the running board and the opposite knee on the seat. Avoid abrupt stops.



Standing

Place both feet on the running boards. Knees should be flexed to absorb the shock from surface bumps. This is an effective position to see better and to shift weight as conditions dictate. Avoid abrupt stop.



Rider Position (Reverse Operation)

When operating in reverse:

- Ensure the path behind is clear of obstacles or bystanders before proceeding in reverse.
- BRP recommends sitting on your snowmobile when operating in reverse.
- Avoid standing up. Your weight could shift forward against throttle lever while operating in reverse, causing an unexpected acceleration. Unexpected acceleration when snowmobile operates in reverse can cause a loss of control.

Fast reverse while turning, could result in loss of stability and control.

Riding with Passenger(s)

This vehicle is designed for one (1) operator and as many passengers as there are seats with straps or handholds installed on the vehicle conforming to SSCC standards. Passenger must only sit on designated passenger seat.

WARNING

- **Never carry a passenger on a seat not approved by BRP.**
- **Never allow anyone to sit between the handlebar and the operator.**

Even when a passenger is allowed, this person must be physically fit for snowmobiling.

Any passenger must always be able to firmly lay his feet on the footrests and keep his hands on the handholds or seat strap when seated. Respecting those physical criteria is important to ensure that the passenger is stable and to reduce the risks of ejection. Falls can result in severe injury or death.

The operator has a responsibility to ensure the safety of his passenger and should inform the passenger about snowmobiling basics.

Before riding the vehicle, adjust suspension according to weight. Refer to *Tune Your Ride* subsection for more details.

Ask your passenger to inform you to slowdown or stop immediately if he feels uncomfortable or insecure during the ride.

When going over bumps, riders(s) may raise their body slightly off the seat to absorb the shocks with their legs.

An unforeseen bump can leave you passenger-less. Remind your passenger to lean into the turn with you, without causing the vehicle to topple. Be extremely careful, go more slowly and check the passenger frequently. Keep a watchful eye on your passenger while riding.

Braking ability and steering control are reduced when riding with a passenger. Decrease speed and allow extra space to maneuver.

Riding Alone

Venturing out alone with your snowmobile could also be hazardous. You could run out of fuel, have an accident, or damage your snowmobile. Remember, your snowmobile is capable of traveling further in half an hour than you may be able to walk in a day. Use the "buddy system". Always ride with a friend or member of your snowmobile club. Even then, tell someone where you are going and the approximate time you plan to return.

Riding in a Group

Before starting out, designate a "trail boss" to lead the party and another person to follow-up at the end of the party. Ensure that all members of the party are aware of the proposed route and destination. When riding with others, limit your abilities to the experience of others. Never overtake the trail boss or, for that matter, any other snowmobile. Use down-the-line hand signals to indicate hazards or intent of direction change. It's important to keep a safe distance between each snowmobile but each one behind the leader should know the position of the machine ahead.

Avoiding Collisions

Wherever riding your vehicle always be on the look-out for the unexpected. Operate defensively. Scan constantly for people, objects, conditions and upcoming vehicles. In the trail, always stay on the appropriate side - as per country regulation - to avoid collision, especially when the field of vision is reduced. E.g.: Before a hilltop and a curve. Use extra caution whenever off-trail.

Always keep a safe distance from other snowmobiles and bystanders. Tailgating another snowmobile should be avoided. If the snowmobile in front of you slows for any reason, its operator and passenger could be harmed through your neglect. Maintain a safe stopping distance between you and the snowmobile in front of you. Depending on the terrain condition, stopping may require a little more space than you think. Play it safe. Be prepared to use evasive driving.

On land or water, fog or visibility-limiting snow can form. If you must proceed into the fog or heavy snow, do so slowly with your lights on and watch intently for hazards. If you are not sure of your way, do not proceed. Keep a safe distance behind other snowmobilers to improve visibility and reaction time.

Riding Behaviors

Injury or death may result to the snowmobile operator, passenger or bystander if the snowmobile is used in risky conditions which are beyond the operator's, passenger's or snowmobile's capabilities or intended use.

Remember, promotional material may show risky maneuvers performed by professional riders under ideal and controlled conditions. You should never attempt any such risky maneuvers if they are beyond your level of riding ability.

Jumping can be a hazardous situation. It requires practice and should be done in a known and controlled environment. Never attempt jumping in a trail. A loss of control could lead to an impact with different elements like rock or tree, or with another snowmobile. When jumping be prepared for landing to absorb the shock. Brace yourself for the impact and your knees must be flexed to act as shock absorbers.

Also, an uneven or mined surface in the trail could be enough to kick upward the snowmobile and generate an impact or a loss of control. When "gunning" the throttle, the vehicle digs into and leaves an irregular snow surface for others. So protect the other users by not spinning the track in the middle of the trail.

Speeding

Excessive speed and reckless driving can be fatal. Always adjust your speed according to snow conditions and circumstances. In many cases, you cannot react or respond quickly enough to the unexpected. Always ride at a speed which is suitable to the trail, weather conditions and your own ability. Know your local rules. Speed limit may be in effect and meant to be observed.

Moving Parts

Stay away from the track. Personal injury will result if contact is made with the rotating track.

To prevent serious injury to individuals near the snowmobile:

- Never stand behind or near a moving track
- Always use a wide-base snowmobile stand with a rear deflector panel if it is necessary to rotate track
- When the track is raised off the ground, only run it at the lowest possible speed. Centrifugal force could cause debris, damaged or loose studs, pieces of torn track, or an entire severed track to be violently thrown backwards out of the tunnel with tremendous force
- Never operate the engine without the belt guard securely installed
- Never operate the vehicle without the brake disk guard securely installed
- Never operate the vehicle with the side panels opened, or the hood removed

Know Terrain and Riding Variations

Groomed Trail

On a maintained trail, sitting is the most preferred riding position. Do not race and, above all, keep to the right hand side of the trail. Be prepared for the unexpected. Observe all trail signs. Do not zigzag from one side of the trail to the other.

Ungroomed Trail

Unless there has been a fresh snowfall you can expect “washboard” and snowdrift conditions. Taken at excessive speeds, such conditions can be physically harmful. Slow down. Hold on the handlebar and assume a posting position. Feet should be under the body assuming a crouched position to absorb any jarring effect. On longer stretches of “washboard” trails, the kneeling position of one knee on the seat can be adopted. This provides a certain amount of comfort, while at the same time keeps the body loose and capable of vehicle control. Beware of hidden rocks or tree stumps partially hidden by a recent snowfall.

Deep Snow

In deep “powder” snow, your vehicle could begin to “bog” down. If this occurs, turn in as wide an arc as possible and look for a firmer base. If you do get “bogged”, and it happens to everyone, do not spin your track as this makes the vehicle sink deeper. Instead, turn the engine off, get off and move the back of the vehicle onto new snow. Then tramp a clear path ahead of the vehicle. A few feet will generally suffice. Restart the engine. Assume the standing position and rock the vehicle gently as you steadily and slowly apply the throttle. Depending on whether the front or rear end of the vehicle is sinking, your feet should be placed on the opposing end of the running boards. Never place foreign material beneath the track for support. Do not allow anyone to stand in front of, or to the rear of, the snowmobile with the engine running. Stay away from the track. Personal injury will result if contact is made with the revolving track.

Frozen Water

Traveling frozen lakes and rivers can be fatal. Avoid waterways. If you are in an unfamiliar area, ask the local authorities or residents about the ice condition, inlets, outlets, springs, fast moving currents or other hazards. Never attempt to operate your snowmobile on ice that may be too weak to support you and the vehicle. Operating a snowmobile on ice or icy surfaces can be very dangerous if you do not observe certain precautions. The very nature of ice is foreign to good control of a snowmobile or any vehicle. Traction for starting, turning or stopping is much less than that on snow. Thus, these distances can be multiplied manyfold. Steering is minimal, and uncontrolled spins are an ever present danger. When operating on ice, drive slowly with caution. Allow yourself plenty of room for stopping and turning.

Slush

Slush should be avoided at all times. Always check for slush before starting across any lake or river. If dark spots appear in your tracks, get off the ice immediately. Ice and water can be thrown rearward into the path of a following snowmobile. Getting a vehicle out of a slush area is strenuous and in some cases, impossible.

Uphill

There are two types of hills you can encounter — the open hill on which there are few trees, cliffs or other obstacles, and a hill that can only be climbed directly. On an open hill, the approach is to climb it by side hilling or slaloming. Approach at an angle. Adopt a standing position with both feet on the same running board. Keep your weight on the uphill side at all times. Maintain a steady, safe speed. Continue as far as you can in this direction, then switch to an opposite hill angle and riding position.

A direct climb could present problems. Choose the standing position, accelerate before you start the climb and then reduce throttle pressure to prevent track slippage.

In either case, vehicle speed should be as fast as the incline demands. Always slow down as you reach the crest. If you cannot proceed further, don't spin your track. Apply the parking brake, turn the engine off, free the skis by pulling them out and downhill, place the rear of the snowmobile uphill, restart the engine, release the parking brake and ease it out with slow even throttle pressure. Position yourself to avoid tipping over, then descend.

Downhill

Downhill driving requires that you have full control of your vehicle at all times. On steeper hills, keep your center of gravity low and both hands on the handlebar. Maintain slight throttle pressure and allow the machine to run downhill with the engine operating. If a higher than safe speed is reached, slow down by braking but apply the brake with frequent light pressure. Never jam the brake and lock the track.

Side Hill

When crossing a side hill or traversing up or downhill, certain procedures must be followed. All riders should lean towards the slope as required for stability. The preferred operating positions are the standing position, with both feet on the running board that is facing uphill. Be prepared to shift your weight quickly as needed. Side hills and steep slopes are not recommended for a beginner or a novice snowmobiler.

Avalanche Hazard

When riding on mountainous terrain, you should be aware of the risk of avalanches. Avalanches vary in size and shapes and generally occur in steep terrain and on unstable snow.

New snow, animals, people, wind and snowmobiles can all trigger an avalanche. Avoid high marking or traversing steep terrain when avalanche conditions are possible. When in unstable snow conditions, travel should be restricted to lower angle slopes. Wind formed cornices should be avoided. Staying off unstable conditions is the key to safe mountain riding. Probably most important is to be aware of the conditions and dangers on a daily basis when in the mountains. Check local avalanche forecasts and threats each day before heading out to ride and heed forecasters advice.

You should always carry a snow shovel, probe and avalanche beacon while riding on mountains.

Bright Sunshine

Bright sunny days can considerably reduce your vision. The glare from sun and snow may blind you to the extent that you cannot easily distinguish ravines, ditches or other obstacles. Goggles with colored lenses should always be worn under these conditions.

Night Rides

The amount of natural and artificial light at a given time can affect your ability to see or to be seen. Be extra cautious. Drive at speeds that will allow you to stop in time when you see an unknown or dangerous object ahead. Stay on established trails and never operate in unfamiliar territory. Be sure both headlights and taillight are working and clean.

Unfamiliar Territory

Whenever you enter an area that is new to you, drive with extreme caution. There may be obstructions hidden beneath the snow. Go slow enough to recognize potential hazards such as fences or fence posts, brooks crossing your path, rocks, sudden dips, guy wires and countless other obstacles which could result in a termination of your snowmobile ride.

Driving off established trails and in the woods requires reduced speed and increased vigilance. Driving too fast in an area can make even minor obstacles very hazardous. Even hitting a small rock or stump could throw your snowmobile out of control and cause injury to its riders. Even when following existing tracks, be cautious. Travel at a speed so you can see what is around the next bend or over the top of the hill.

Hidden Wires

Always be on the lookout for hidden wires, especially in areas that may have been farmed at one time or another. Too many accidents have been caused by running into wires in the fields, guy wires next to poles and roads, and into chains and wires used as road closures. Slow speeds are a must.

Riding Uneven Surfaces

Unplanned jumps of snowdrifts, snowplow ridges, culverts, indistinguishable objects or sudden drop in the trail can be dangerous. You can avoid them by wearing the proper color lenses or face shields and by operating at a lower speed.

A good way to help seeing these terrain variations is to wear the proper color lenses or face shields and by operating at a lower speed. Crouch (stand) towards the rear of the vehicle and keep the skis up and straight ahead. Apply partial throttle and brace yourself for the impact. Knees must be flexed to act as shock absorbers.

Road Crossing

Your snowmobile is not designed to operate or turn on pavement of public streets, roads or highways. Avoid road traveling. If you must do so, and it is permitted, reduce speed and stay on the edge of the way where you can find snow to help providing capabilities to maintain directional control.

As snowmobile trails often cross roadways it is important for riders to know the proper crossing procedures. When approaching a roadway, signal to others that you are stopping at the intersection and slowly come to a complete stop back from the road's edge. In some cases, you will be approaching the road from a ditch or snowbank. Choose a place where you know you can climb without difficulty. Stop completely at the top of the bank and wait for all traffic to clear. Then, look carefully in both directions before crossing at a 90° angle. If needed, assume a standing position to look both ways. Be wary of parked vehicles. When you are certain that the road is clear proceed straight across the intersection without hesitation. Each rider needs to come to a complete stop, look both ways and then proceed when the roadway is clear of oncoming traffic.

Railroad Crossing

Never ride on railroad tracks. It is illegal. Railroad tracks and railroad rights-of-way are private property. A snowmobile is no match for a train. Before crossing a railroad track, stop, look and listen.

Respect of the Wildlife

Wildlife compliments your snowmobiling day. Snowmobile tracks provide firm ground over which animals can travel from area to area. Do not violate this privilege by chasing or harassing wildlife. Fatigue and exhaustion can lead to animal's death. Avoid areas posted for the protection or feeding of wildlife. If you happen to be fortunate enough to see an animal, stop your snowmobile and observe quietly.

Carbon Monoxide (CO) Poisoning

All engine exhaust contains carbon monoxide (CO), a deadly gas. Breathing carbon monoxide can cause headaches, dizziness, drowsiness, nausea, confusion and eventually death.

Carbon monoxide is a colorless, odorless, tasteless gas that may be present even if you do not see or smell any engine exhaust. Deadly levels of carbon monoxide can collect rapidly, and you can quickly be overcome and unable to save yourself. Also, deadly levels of carbon monoxide can linger for hours or days in enclosed or poorly ventilated areas.

If you experience any symptoms of carbon monoxide poisoning, leave the area immediately, get fresh air and seek medical treatment.

To prevent serious injury or death from carbon monoxide:

- Never run the vehicle in poorly ventilated or partially enclosed areas such as garages, carports or barns. Even if you try to ventilate engine exhaust with fans or open windows and doors, carbon monoxide can rapidly reach dangerous levels.
- Never run the vehicle outdoors where engine exhaust can be drawn into a building through openings such as windows and doors.
- Never stand next to the vehicle while the engine is running. A person standing next to the vehicle when the engine is running may inhale high concentrations of exhaust fumes.

After riding, always remove the tether cord from the engine cut-off switch to avoid unauthorized use by children or others and to prevent starting in a closed environment (ex: garage).

Gasoline Fires and Other Hazards

Gasoline is extremely flammable and highly explosive. Fuel vapors can spread and be ignited by a spark or flame many feet away from the engine. To reduce the risk of fire or explosion, follow these instructions:

- Use only an approved gasoline container to store fuel.
- Strictly adhere to instructions in *Vehicle Fueling Procedure*.
- Never start or operate the engine if the fuel cap is not properly installed.
- Use only a BRP approved LinQ fuel caddy to carry extra fuel on the vehicle. It should be properly installed and secured.

Gasoline is poisonous and can cause injury or death.

- Never siphon gasoline by mouth.
- If you swallow gasoline, get any in your eye or inhale gasoline vapor, visit your doctor immediately.
- If gasoline spills on you, wash with soap and water and change your clothes.

Burns from Hot Parts

Certain components may become hot during operation. Avoid contact during and shortly after operation to avoid burns.

PRACTICE EXERCISES

Practice alone the following exercises after having done the entire Pre-ride inspection. Always start and stop the engine according to the instructions in *ENGINE STARTING PROCEDURE* and *SHUTTING OFF THE ENGINE* in *BASIC PROCEDURES*. Don't forget to attach the tether cord to your jacket.

Where to Practice Exercises

Find a suitable area to practice the exercises. Ensure the area meet the following requirements:

- No traffic
- No obstacles
- Hard packed snow
- Ample space to maneuver.

Exercises to Practice

Practice alone the following exercises after having done the entire Pre-ride inspection. Always start and stop the engine according to the instructions in *ENGINE STARTING PROCEDURE* and *SHUTTING OFF THE ENGINE* in *BASIC PROCEDURES*. Don't forget to attach the tether cord to your jacket.

Using the Emergency Engine Stop Switch

Purpose: Become familiar with the operation of throttle lever and to become familiar with using the engine stop switch.

Directions:

- With the parking brake engaged, start the engine and let idle until it reaches the operation temperature.
- Use the engine stop switch to shut the engine off. Turn the switch with your right thumb while keeping your hand on the handgrip.
- Restart the engine and repeat the exercise. No idle time is required.

Tips for additional practice:

- Turn the emergency engine stop switch without looking at it.

Starting, Stopping and Basic Handling

Purpose:

- Learn throttle control and how to get the vehicle moving.
- Become familiar with low speed deceleration and braking.

If you feel like you are losing control while doing this exercise, release the throttle to stop accelerating and apply the brake as needed to slow down. You can also use the engine stop switch to cut power entirely.

Directions: At first, you will only use the throttle for a moment at a time, then release it and coast.

- Start the engine and release the parking brake lever.
- Slowly apply throttle until the vehicle starts to creep forward. As soon as you start moving release the throttle and coast, then press the brake lever to stop.
- Continue with this part of the exercise until you are comfortable with applying and releasing the throttle.

Engine Stop While in Motion

Purpose: Become familiar with using the emergency engine stop switch when in motion so you know how the vehicle will react if you need to use it later.

Directions:

- Partway down the straightaway, while operating at 8 km/h (5MPH), toggle the engine stop switch to OFF position and coast to a stop.
- Restart the engine and repeat the exercise. Try increasing your speed (to a maximum of 20 km/h (12MPH) before using the engine stop switch.

In an emergency, the snowmobile engine can be stopped by turning the emergency engine stop switch or by pulling the tether cord cap from the engine cut-off switch, while applying brake.

Basic Turns

Purpose: Get comfortable turning in a controlled manner on both sides.

Directions:

- Roll in a straight line at low speed and make a wide arcing turn. Make sure there is enough space to perform the entire turn.
- Repeat right and left turns and maintain a steady speed below 8km/h (5MPH). Hold the throttle to maintain your low speed.
- Leaning forward and into the curve may help you to turn the handlebar more easily.

Quick Stops

Purpose:

- Become familiar with the vehicle braking ability.
- Learn to apply brakes with maximum efficiency.

This exercise is like what you did before, except you'll be applying the brake more firmly, working up to braking at the maximum without locking the track rotation. Always release the throttle completely for quick stops. If you apply throttle and brake at the same time, your stopping distance will be longer.

Directions:

- Start at one end of the straightaway and accelerate to 8 km/h (5MPH). Partway down the straightaway, release the throttle completely and brake quickly.
- Keep head and eyes up, keep handlebar straight, and do not release the brake until fully stopped.
- Repeat, increasing your speed and braking harder. When you feel that the rotation of the track will be stopped you need to release the pressure on the break lever. To maintain control, you need to keep the track in rotation.

FUELING

Fuel is flammable and explosive under certain conditions.

- Never use an open flame to check fuel level.
- Never smoke or allow flame or spark in vicinity.
- Always proceed in a well-ventilated area.

Fueling Procedure

1. Stop engine and engage the parking brake.
2. Have operator and passenger get off the vehicle. Do not sit or lean on seat when fuel tank cap is not properly installed.
3. Unscrew slowly the fuel reservoir cap counterclockwise to stabilize pressure before removing it.

NOTE:

A short whistling sound is normal.

4. Insert the spout into the filler neck.
5. Pour fuel slowly so that air can escape from the tank and prevent fuel flow back. Be careful not to spill fuel.
6. Stop filling after the release of the gas pump nozzle handle and wait a moment before removing the spout. Do not retract the gas pump nozzle to put more fuel into the fuel tank. **Do not overfill.**
7. Reinstall the fuel cap and fully tighten clockwise.
8. Always wipe off any small fuel spillage from the vehicle. If a major spillage occurs, remove side panels to remove fuel vapors from engine compartment before starting.
9. Before getting on the way don't forget to disengage the parking brake.
10. Never top up the fuel tank before placing the vehicle in a warm area. As temperature increases, fuel expands and may overflow.

VEHICLE TRANSPORTATION

Make sure that oil reservoir and fuel tank caps are properly installed.

Tilt bed trailers can easily be equipped with a winch mechanism to afford maximum safety in loading. Many serious accidents have resulted from driving up and over a trailer.

Anchor your vehicle securely, front and rear, even on short hauls. Make sure all equipment is securely fastened. Cover your snowmobile when trailering to prevent road grime from causing damage.

Be certain your trailer meets state or provincial requirements. Ensure the hitch and safety chains are secure, and the brake, turn indicators and clearance lights all function.

 **WARNING**

Make sure all seats, accessories and cargo are properly secured, or remove it to prevent from falling on the road and creating a hazard for following vehicles.

IMPORTANT ON-PRODUCT LABELS (CANADA/UNITED STATES)

Vehicle Safety Labels

These labels are affixed to the vehicle for the safety of the operator, passenger or bystanders.

The following labels are on your vehicle and they should be considered permanent parts of the vehicle. If missing or damaged, the decals can be replaced free of charge. Visit an authorized BRP snowmobile dealer.

NOTE:

In the event of any discrepancy between this guide and the vehicle, the safety labels on the vehicle have precedence over the labels in this guide.

Shock Absorber - Warning Label



WARNING

- This shock absorber is pressurized.
- An explosion may occur if heated or punctured.
- Do not disassemble.

SHOCK ABSORBERS - WARNING LABEL

Disconnect Fuel Injectors - Warning Label

<p>AVERTISSEMENT</p> <p>Toujours débrancher les connecteurs électriques des deux injecteurs d'essence avant de vérifier la production d'étincelles. Autrement, une étincelle pourrait allumer des vapeurs d'essence, ce qui représenterait un risque de feu.</p>	<p>⚠</p> <p>AVERTISSEMENT</p>	<p>⚠</p> <p>WARNING</p>	<p>Always electrically disconnect both fuel injectors prior to testing for ignition spark. Otherwise, fuel vapors may ignite in presence of a spark creating a fire hazard.</p>	<p>516007661</p>
---	---	---------------------------------------	---	------------------

DISCONNECT FUEL INJECTORS - WARNING LABEL

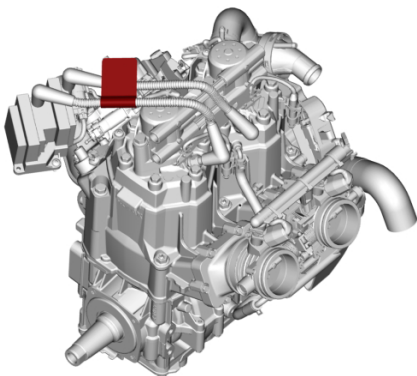

Pulley Guard and Drive Pulley Tightening Torque - Warning and Notice Label

⚠ WARNING / AVERTISSEMENT

This guard must ALWAYS be in place when the engine is running. Beware of rotating parts, they could cause injuries or catch your clothing.

Ce protecteur doit TOUJOURS être en place lorsque le moteur tourne, les pièces en rotation peuvent provoquer des blessures ou prendre dans vos vêtements.

NOTICE

Drive pulley bolt recommended torque:
115-125 Nm (85-92 lbf-ft)

Not applying the recommended torque may result in a major failure of the drive pulley and the engine. Refer to the shop manual for the complete assembly procedure.

108998

PULLEY GUARD AND DRIVE PULLEY TIGHTENING TORQUE – WARNING AND NOTICE LABEL

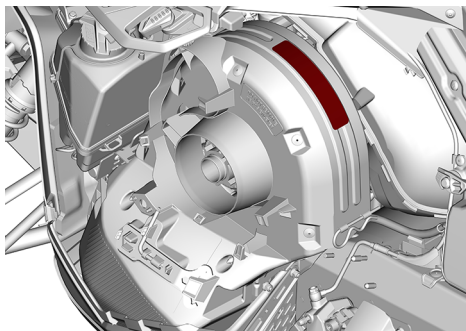

Do Not Open When Hot - Warning Label

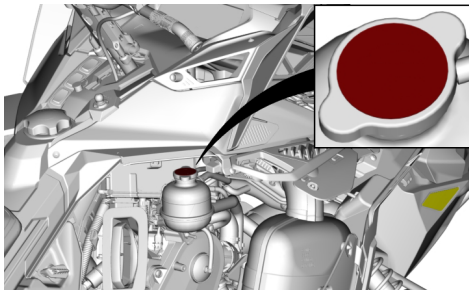

Do Not Open When Hot - Warning Label

 **WARNING**

Do not open when hot.

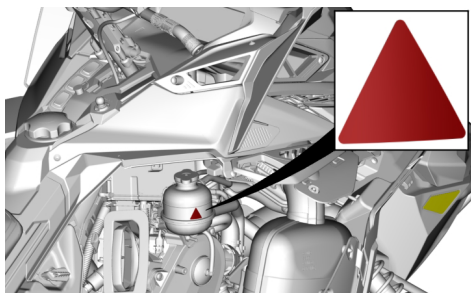

Beware of Hot Parts - Caution Label

 **CAUTION**

Beware of hot parts.

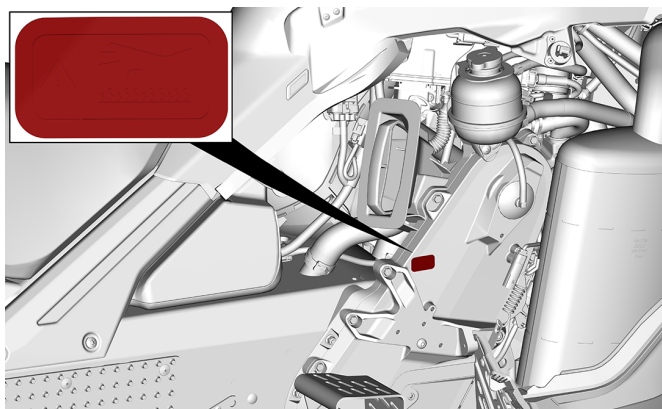

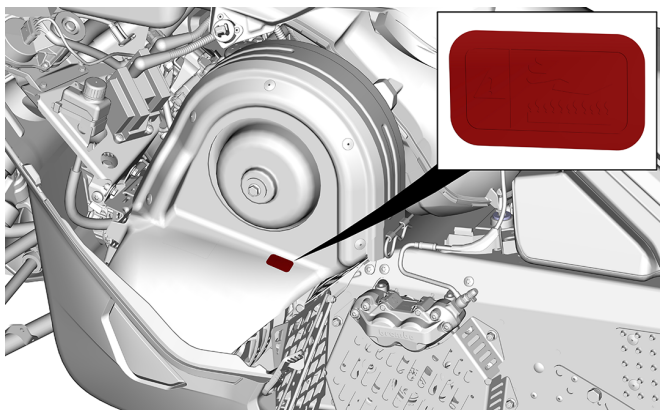

Disk Guard - Warning Label



DISK GUARD - WARNING LABEL

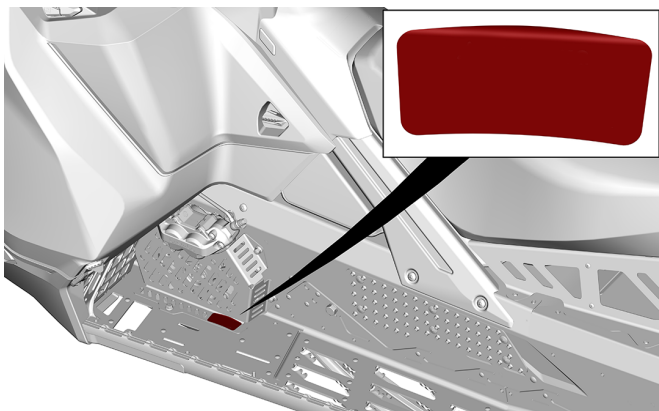

Starting Procedure - Warning Label

⚠ WARNING



- Read and understand all safety labels, locate and read operator's guide and watch the safety video (using the QR code link or visit Ski-Doo web site) before operation. 
- Get familiar with your vehicle. Inexperienced riders may overlook risks and be surprised by vehicle's specific behavior and terrain conditions. Ride slowly.
- Excessive speed and reckless driving can kill.
- ALWAYS adjust your speed according to snow conditions and circumstances.
- Steering control and braking ability may be reduced on hard-pack snow, ice or roads. Reduce speed & allow more space to stop or turn.
- Respect laws on minimum operator age. Manufacturer recommends a minimum operating age of 16 years old.
- Never open side panels or hood while engine is running or if vehicle is in motion. Ensure to remove tether cord from post before opening those.

BEFORE STARTING :

1. Attach tether cord to your clothing.
2. Check proper operation of the throttle and brake levers each time before starting. They must return to their initial position when released.
3. Apply parking brake.
4. Turn handlebars all the way in both directions to check for interference and insure free operation.

AFTER STARTING :

1. Pull-out tether cord to check if engine shuts off.
2. Re-start and push in the emergency engine stop switch to check if engine shuts off.
3. Disengage parking brake before riding to avoid brake fading.



516010681

STARTING PROCEDURE – WARNING LABEL

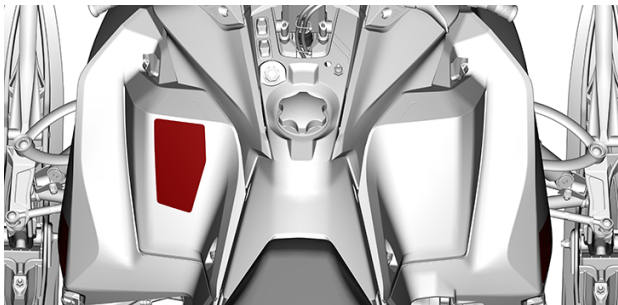

Passenger Safety - Warning Label

▲ WARNING

When riding with a passenger:

- Braking ability and steering control are reduced.
- Decrease speed and allow extra space to manoeuvre.
- Adjust suspension according to weight.

Remember: you are responsible for the safety of your passenger. All drivers and passengers must read the following:

- Avoid surprises, be on the look out for the unexpected.
- Operate defensively, scan constantly for people, objects, conditions and upcoming vehicles.
- Avoid thin ice / open water.
- Use extra caution whenever off-trail.



- Always wear an approved helmet and clothing appropriate for snowmobiling.



- Never ride under the influence of alcohol or drugs, even as a passenger.



Patent: www.brazos.com/usa/our-brp/patent.html

▲ WARNING / AVERTISSEMENT

This vehicle is designed for one (1) operator and as many passengers as there are seats with straps or handgrips installed on the vehicle conforming to SSCC standards.

Ce véhicule a été conçu pour un (1) conducteur et autant de passagers qu'il y a de sièges avec courroies ou poignées installées sur le véhicule et rencontrant la norme SSCC.

11023

PASSENGER SAFETY - WARNING LABEL

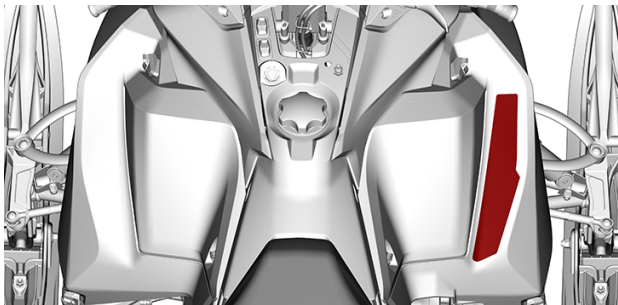

Maximum Cargo Load and Towing Capacity – Warning Label

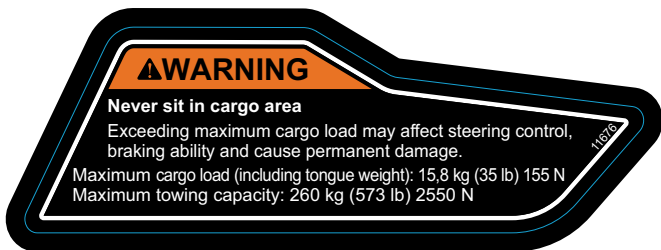

CARGO AREA – WARNING LABEL

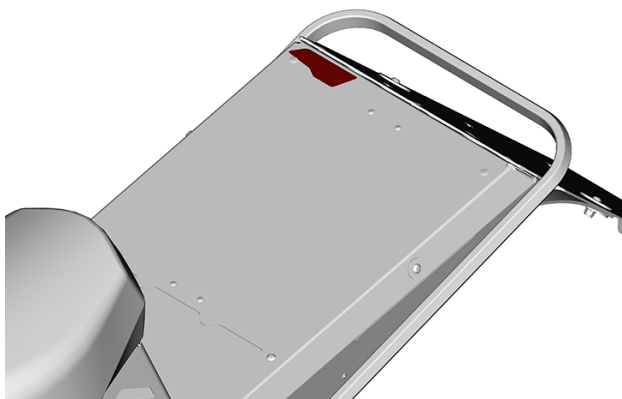

LABEL LOCATION

Rotating Track - Warning Label

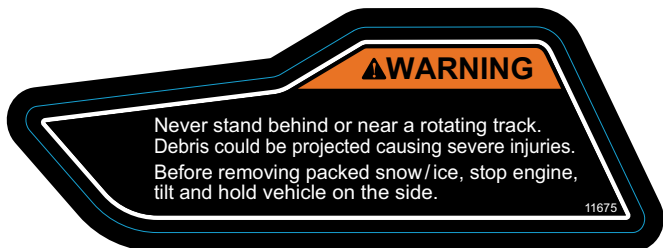

ROTATING TRACK – WARNING LABEL



LABEL LOCATION

Technical Information Labels

Recommended Fuel — Notice Label

Refer to the *Technical Specifications* for appropriate fuel type for your vehicle engine.

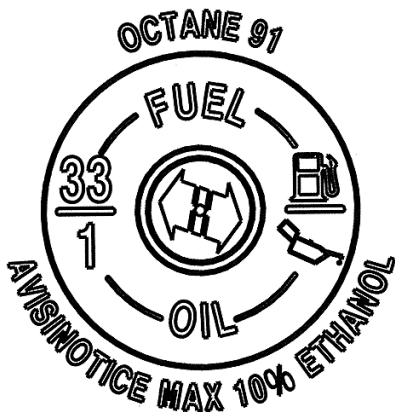

ON FUEL CAP - IN COUNTRIES USING PUMP POSTED AKI
(RON+MON)/2 OCTANE RATINGS

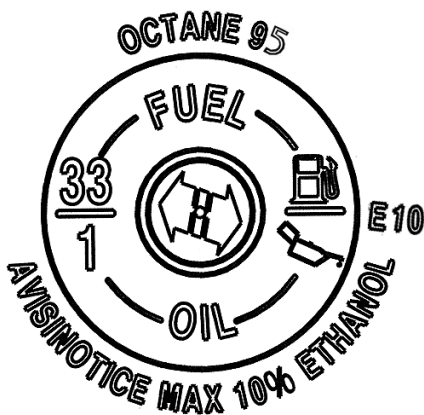

ON FUEL CAP - IN COUNTRIES USING RON OCTANE RATINGS

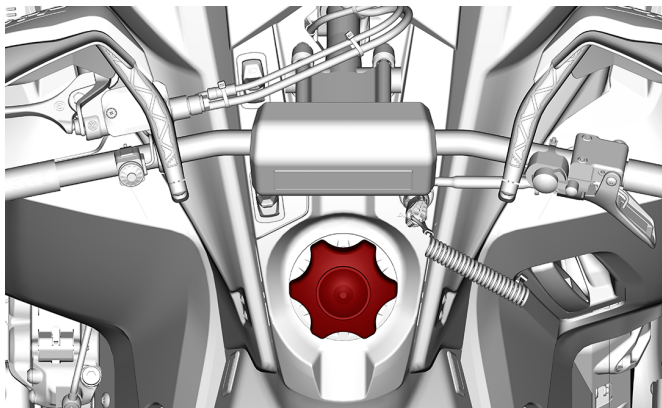

Clicker Adjustment Label

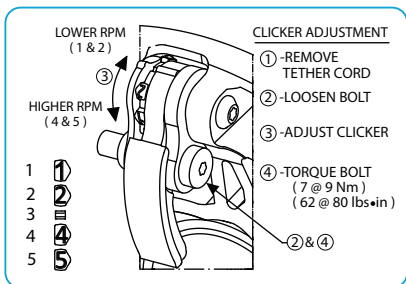

CLICKER ADJUSTMENT - NOTICE LABEL

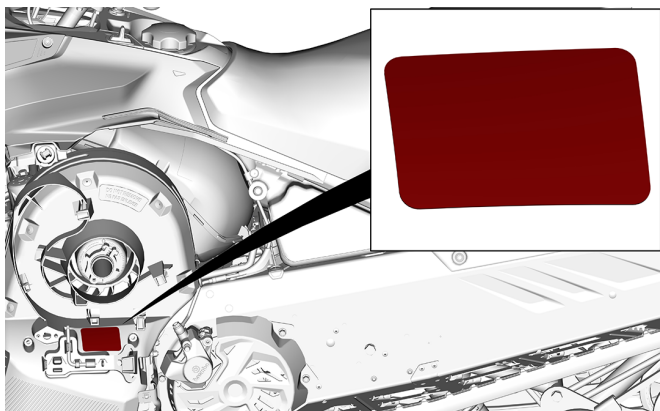

TYPICAL

Competition Usage Only – Notice Label

NOTICE

This snowmobile is a competition model only and is not manufactured for, nor should it be used for general off-road recreational riding. Using this snowmobile in any manner other than competition may be a violation of FEDERAL LAW subject to civil penalty

BOMBARDIER RECREATIONAL PRODUCTS INC.

7769

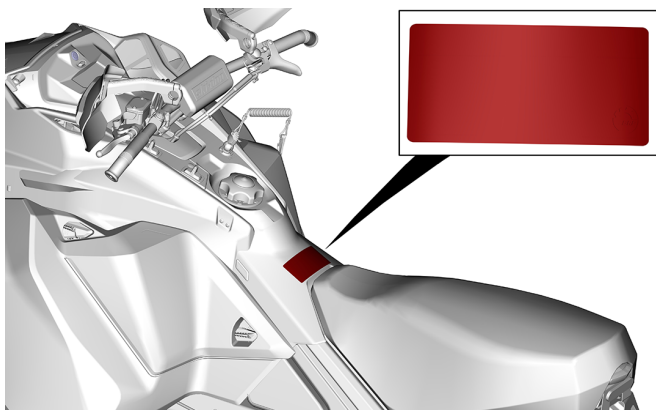

Shock Position – Notice Label

NOTICE

Place reservoir facing downwards
when installing shock.

5609A

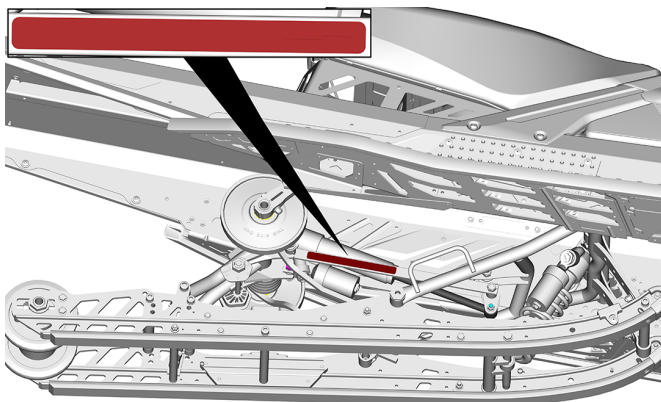
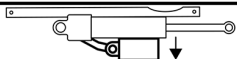

IMPORTANT ON-PRODUCT LABELS (ALL COUNTRIES EXCEPT CANADA/UNITED STATES)

This vehicle comes with a hang tag and labels containing important safety information.

Any person who rides this vehicle should read and understand this information before riding.

Vehicle Safety Labels

These labels are affixed to the vehicle for the safety of the operator, passenger or bystanders.

The following labels are on your vehicle and they should be considered permanent parts of the vehicle. If missing or damaged, the decals can be replaced free of charge. Visit an authorized BRP snowmobile dealer.

NOTE:

In the event of any discrepancy between this guide and the vehicle, the safety labels on the vehicle have precedence over the labels in this guide.

Shock Absorber - Warning Label

 WARNING
<ul style="list-style-type: none">• This shock absorber is pressurized.• An explosion may occur if heated or punctured.• Do not disassemble.

SHOCK ABSORBERS - WARNING LABEL

Disconnect Fuel Injectors - Warning Label

⚠ WARNING

- Always electronically disconnect both fuel injectors prior to testing for ignition spark.
- Otherwise fuel vapors may ignite in presence of a spark creating a fire hazard.

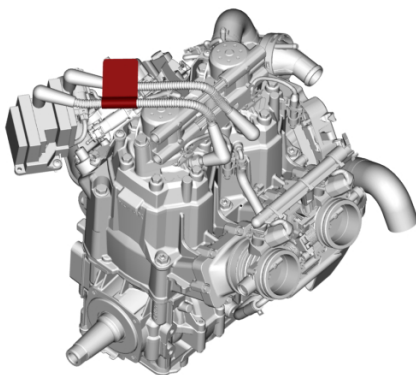
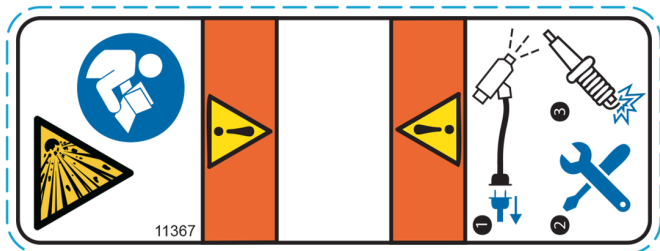

Pulley Guard and Drive Pulley Tightening Torque - Warning and Notice Label

WARNING

This guard must ALWAYS be in place when engine is running. Beware of rotating parts, they could cause injuries or catch your clothing.

NOTICE

- Drive pulley bolt recommended torque is 115 to 125 Nm (85 to 92 lbf-ft).
- Not applying the recommended torque may result in a major failure of the drive pulley and the engine.
- Refer to the service manual for the complete assembly procedure.

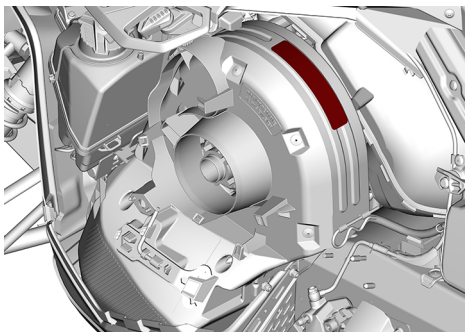
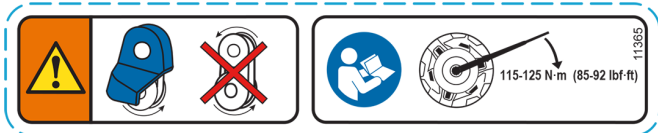

**IMPORTANT ON-PRODUCT LABELS (ALL COUNTRIES EXCEPT CANADA/
UNITED STATES)**

Do Not Open When Hot - Warning Label

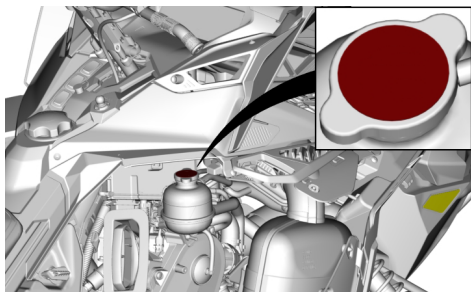

Do Not Open When Hot - Warning Label

 **WARNING**

Do not open when hot.

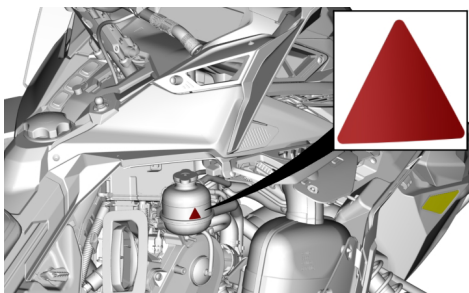

IMPORTANT ON-PRODUCT LABELS (ALL COUNTRIES EXCEPT CANADA/
UNITED STATES)

Beware of Hot Parts - Caution Label

 CAUTION

Beware of hot parts.

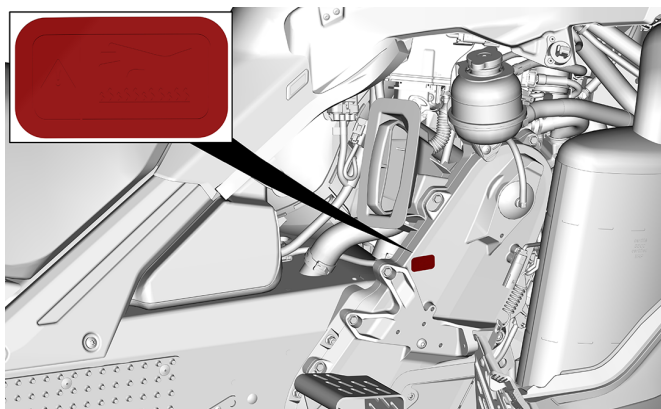

**IMPORTANT ON-PRODUCT LABELS (ALL COUNTRIES EXCEPT CANADA/
UNITED STATES)**

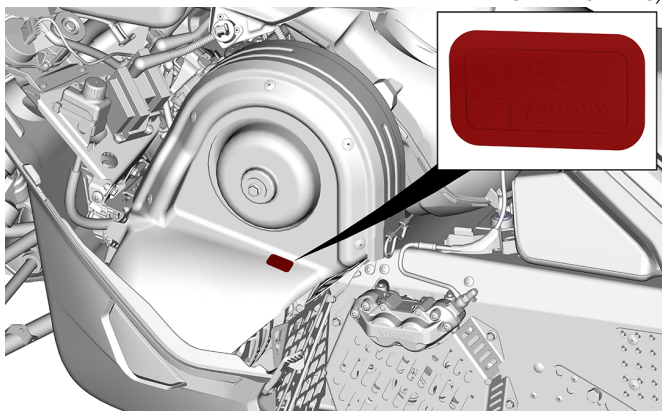

IMPORTANT ON-PRODUCT LABELS (ALL COUNTRIES EXCEPT CANADA/
UNITED STATES)

Disk Guard - Warning Label

! WARNING

This guard must ALWAYS be in place when engine is running.



DISK GUARD – WARNING LABEL

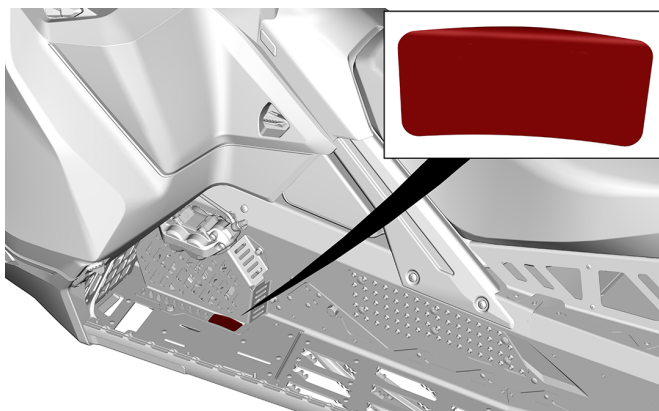

Starting Procedure - Warning Label

WARNING

- Read and understand all safety labels, locate and read the operator's guide and watch the safety video (using the QR code link or visit Ski-Doo web site) before operation.
 - Respect laws on minimum operator age. Manufacturer recommends a minimum operating age of 16 years old.
 - ALWAYS wear ear protection.
 - Get familiar with your vehicle. Inexperienced riders may overlook risks and be surprised by vehicle's specific behavior and terrain conditions. Ride slowly.
 - Excessive speed and reckless driving can kill.
 - ALWAYS adjust your speed according to snow conditions and circumstances.
 - Steering control and braking ability may be reduced on hard-pack snow, ice or roads. Reduce speed & allow more space to stop or turn.
 - Never open side panels or hood while engine is running or if vehicle is in motion. Ensure to remove tether cord from post before opening those.
1. Attach tether cord to your clothing.
 2. Check proper operation of the throttle and brake levers each time before starting. They must return to their initial position when released.
 3. Apply parking brake.
 4. Start engine.
 5. Push in the emergency engine stop switch to check if engine shuts off.
 6. Re-start engine.
 7. Pull-out tether cord to check if engine shuts off.
 8. Re-start engine.
 9. Disengage parking brake before riding to avoid brake fading.

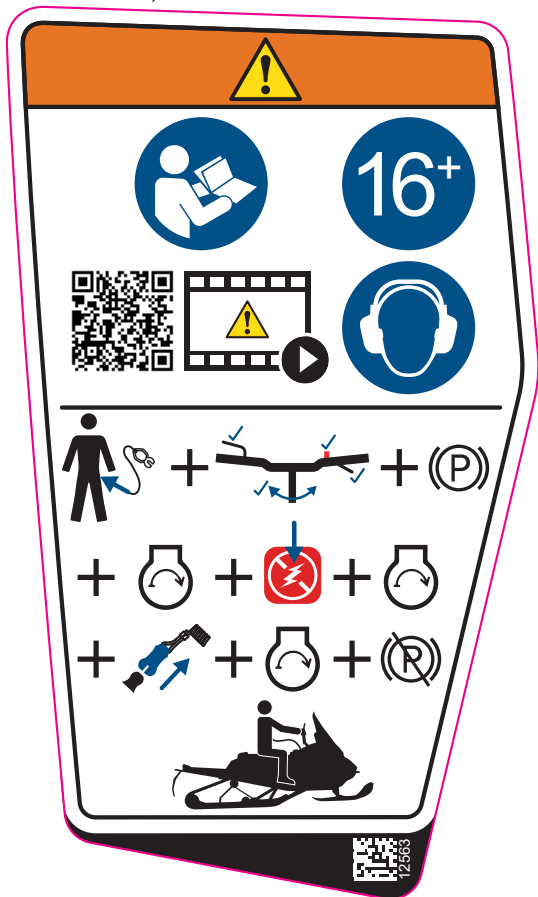

STARTING PROCEDURE - WARNING LABEL

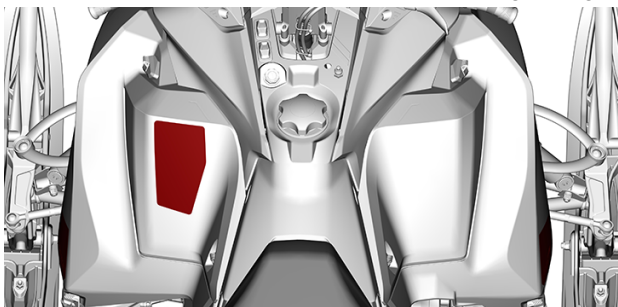

Passenger Safety - Warning Label

 **WARNING**

Remember: you are responsible of the safety of your passenger.

All drivers and passengers must read the following:

- Always wear an approved helmet and clothing appropriate for snowmobiling.
- Operate defensively, scan constantly for people, objects, conditions and upcoming vehicles.
- Avoid surprise, be on the look out for the unexpected.
- Use extra caution whenever off-trail.
- Avoid thin ice/ open water.
- Never ride under the influence of alcohol or drugs, even as passenger.
-

This vehicle is design for one (1) operator and as many passengers as there are seats with straps or handgrips installed on the vehicle conforming to SSCC standards.

When riding with a passenger:

- Braking ability and steering control are reduced.
- Decrease speed and allow extra space to maneuver.
- Adjust suspension according to weight.



PASSENGER SAFETY - WARNING LABEL

**IMPORTANT ON-PRODUCT LABELS (ALL COUNTRIES EXCEPT CANADA/
UNITED STATES)**

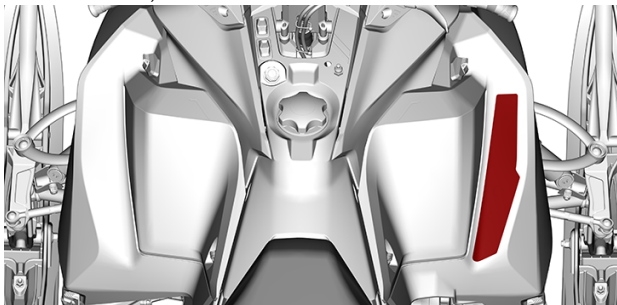

Maximum Cargo Load and Towing Capacity — Warning Label

WARNING

- Never sit in the cargo area.
- Always use a securely fastened rigid tow bar to tow.
- Refer to the operator's guide for more details.
- Exceeding maximum cargo may affect steering control, braking ability and cause permanent damage.
- **MAXIMUM** cargo load (including tongue weight): 15.8 kg (155 N)
- **MAXIMUM** towing capacity: 260 kg (2550 N)



MAXIMUM CARGO LOAD AND TOWING CAPACITY — WARNING LABEL

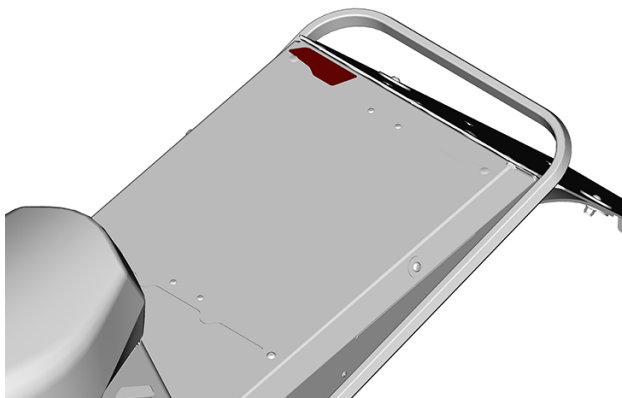

LABEL LOCATION

Rotating Track — Warning Label

⚠ WARNING

- NEVER stand behind or near a rotating track. Debris could be projected causing severe injuries.
- To remove packed snow/ ice, stop engine, tilt and hold vehicle on the side and use wrench tool on the belt guard.

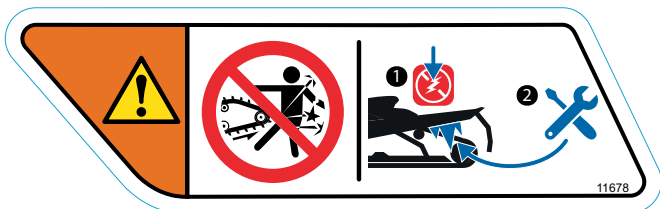

ROTATING TRACK — WARNING LABEL



LABEL LOCATION

Technical Information Labels

Recommended Fuel — Notice Label

Refer to the *Technical Specifications* for appropriate fuel type for your vehicle engine.

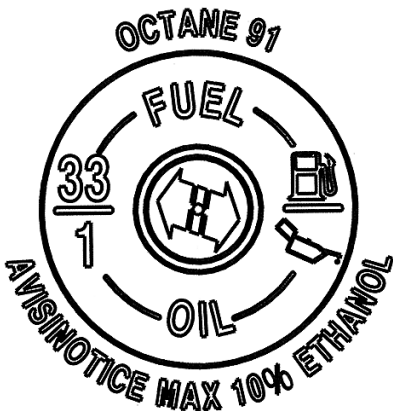

ON FUEL CAP - IN COUNTRIES USING PUMP POSTED AKI
(RON+MON)/2 OCTANE RATINGS

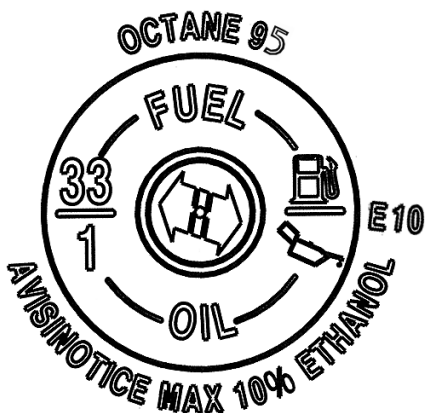

ON FUEL CAP - IN COUNTRIES USING RON OCTANE RATINGS

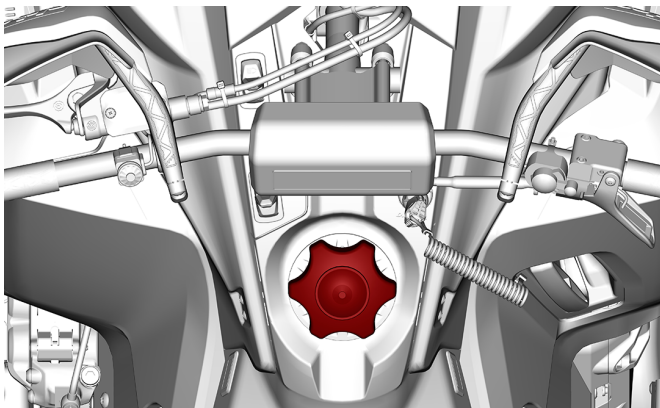

Clicker Adjustment Label

1. Remove tether cord.
2. Remove pulley expander from pulley guard.
3. Loosen bolt.
4. Adjust clicker.

5. Torque bolt.

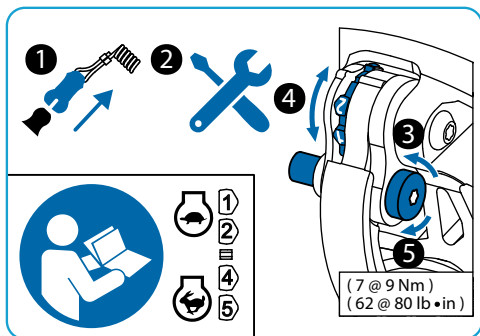

CLICKER ADJUSTMENT LABEL

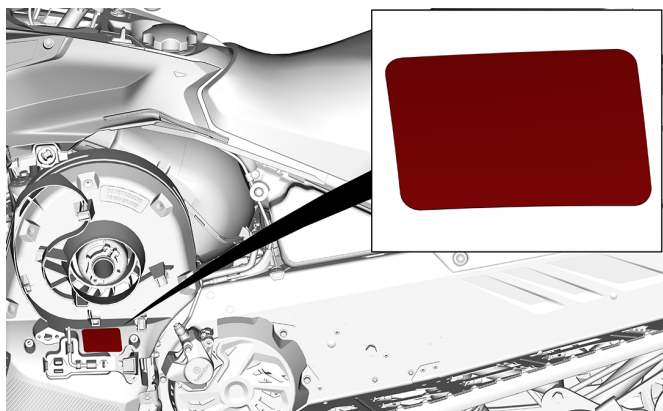

TYPICAL

Competition Usage Only – Notice Label

NOTICE

This snowmobile is a competition model only and is not manufactured for, nor should it be used for general off-road recreational riding. Using this snowmobile in any manner other than competition may be a violation of FEDERAL LAW subject to civil penalty

BOMBARDIER RECREATIONAL PRODUCTS INC.



7769

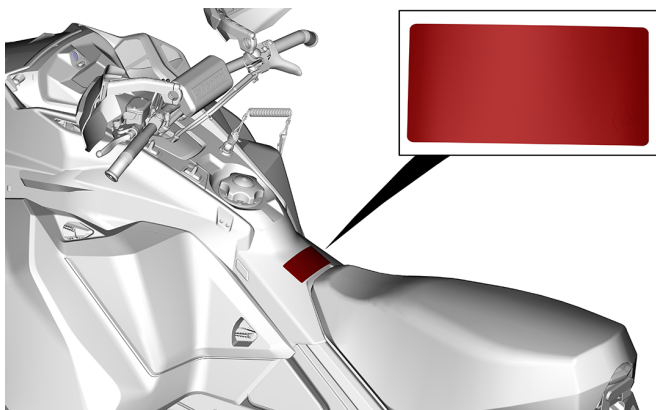

Shock Position – Notice Label

NOTICE

Place reservoir facing downwards
when installing shock.

5609A

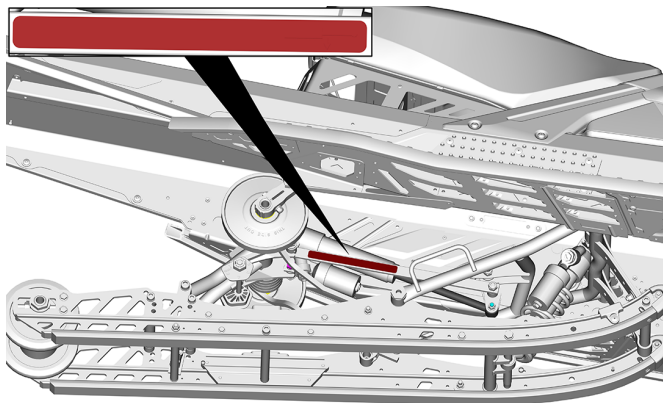

PRE-RIDE INSPECTION

Perform a pre-ride inspection before each ride to detect potential problems during operation. The pre-ride inspection can help you monitor wear and deterioration before they become a problem. Correct any problems that you discover to reduce the risk of an accident or a malfunction.

Before Starting the Engine

1. Remove snow and ice from body including lights, seat, footrests, controls and instruments.
2. Remove packed snow and ice from the rear suspension using the wrench tool stored on the drive belt guard.
3. Verify that air silencer prefilter is free of snow.
4. Verify that skis and steering operate freely. Check corresponding action of skis versus handlebar.
5. Check fuel for level and leaks. Replenish if necessary and in case of any leaks; you should seek service from an authorized BRP snowmobile dealer, repair shop, or person of your own choosing for maintenance, repair, or replacement.
6. All storage compartments must be properly latched and they must not contain any heavy or breakable objects. Hood and side panels must be also properly latched.
7. Activate the throttle control lever several times to check that it operates easily and smoothly. It must return to idle position when released.
8. Activate the brake lever and make sure the brake fully applies before the brake control lever touches the handlebar grip. It must fully return when released.
9. Apply parking brake and check if it operates properly. Leave parking brake applied.
10. Inspect drive belt condition and height. Refer to *Drive Belt* in *Maintenance Procedures*.

After Engine is Started

For proper engine starting procedure, refer to the appropriate *Engine Starting Procedure*.

1. Check headlights high beam and low beam, taillight, stop light and pilot lamps operation.

NOTE:

You may need to detach tether cord from your clothes to check lights. In such a case, attach cord as soon as you get back at the controls of the snowmobile.

2. Check the engine cut-off switch (by pulling tether cord cap) and emergency engine stop switch operation.
3. Release parking brake.
4. Refer to *Vehicle warm up* and follow instructions.

Pre-Ride Check List

ITEM	OPERATION	✓
BODY INCLUDING SEAT, FOOTRESTS, LIGHTS, AIR FILTER, CONTROLS AND INSTRUMENTS	Check condition and remove snow or ice.	
SKIS AND STEERING ACTION	Check for free movement and proper operation.	
SKI RUNNERS	Check for abnormal wear.	
FUEL	Check for proper level and no leaks.	
INJECTION OIL (IF APPLICABLE)	Check for proper level and no leaks.	
COOLANT	Check for proper level and no leaks.	
DRIVE BELT	Check for cracks, fraying or abnormal wear and proper height.	
THROTTLE LEVER	Check for proper operation.	
BRAKE LEVER	Check for proper operation.	
PARKING BRAKE, BRAKE	Check for proper operation.	
BRAKE FLUID	Check for proper level and no leaks.	
STORAGE COMPARTMENT	Check for proper latching and no heavy or breakable objects.	
TRACK	Check condition and remove snow or ice. For studded tracks, refer to <i>Traction Enhancing Products</i> .	
SLIDER SHOES	Check for abnormal wear.	
EMERGENCY ENGINE STOP SWITCH AND ENGINE CUT-OFF	Check for proper operation. Tether cord must be attached to operator clothing eyelet.	

PRE-RIDE INSPECTION

SWITCH (TETHER CORD CAP)		
LIGHTS	Check for proper operation.	
HORN BUTTON (IF EQUIPPED)	Check for proper operation.	

REPORTING SAFETY DEFECTS

In Canada, if you believe that your vehicle has a defect which could cause a crash or could cause injury or death, you should immediately inform Transport Canada in addition to notifying Bombardier Recreational Products Inc.

If Transport Canada receives similar complaints, it may open an investigation, and if it finds that a safety defect exists in a group of vehicles, it may order a recall and remedy campaign. However, Transport Canada cannot become involved in any individual problems between you, your dealer or Bombardier Recreational Products Inc.

To contact Transport Canada:



819-994-3328 (Gatineau-Ottawa area or internationally)
Toll free : 1 800-333-0510 (in Canada)



Transport Canada - ASFAD
330 Sparks Street
Ottawa, ON
K1A 0N5



<https://www.tc.gc.ca/recalls>

This page is intentionally blank

VEHICLE INFORMATION

PRIMARY CONTROLS

Handlebar

The handlebar controls the steering of the snowmobile. As the handlebar is rotated to right or left, the skis are turned right or left to steer the snowmobile.

WARNING

Fast reverse while turning, could result in loss of stability and control.

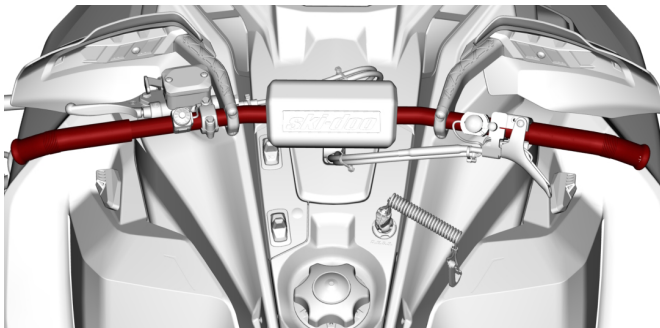

Throttle Lever

Throttle lever is located on the RH side of handlebar.

When squeezed, it increases the engine speed. When released, engine speed returns automatically to idle.

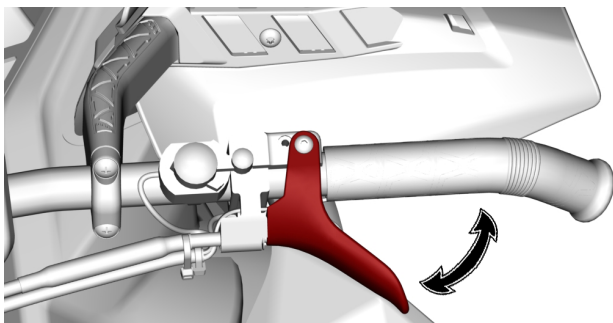

⚠ WARNING

Test the throttle lever operation each time before starting the engine. The lever must return to the rest position once released. Otherwise, do not start engine.

Emergency Engine Stop Switch

The emergency engine stop switch is located on the RH side of handlebar.

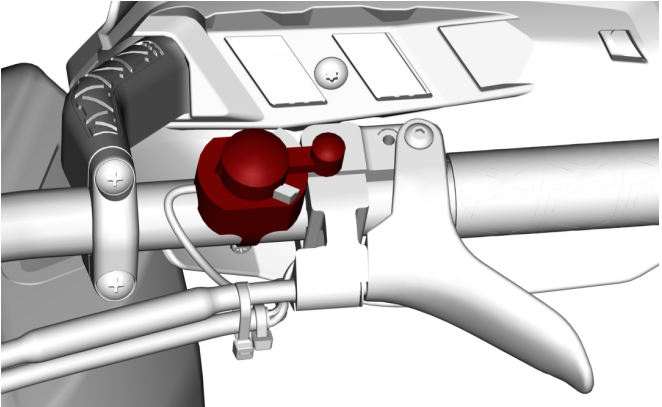

To stop the engine in an emergency, select OFF position and simultaneously apply the brake. To restart, button must be at the ON position.

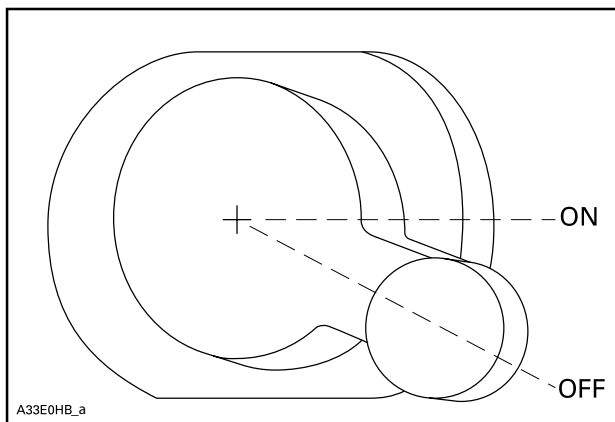

All operators of the snowmobile should familiarize themselves with the function of the emergency engine stop switch by using it several times on first outing and whenever stopping the engine thereafter. This engine stopping procedure will become a reflex and will prepare operators for emergency situations requiring its use.

⚠ WARNING

If the switch has been used in an emergency caused by a suspected malfunction, the source of the malfunction should be determined and corrected before restarting engine. Visit an authorized BRP snowmobile dealer for servicing.

Brake Lever

Brake lever is located on the LH side of handlebar.

When squeezed, brake is applied. When released, it automatically returns to the rest. Braking effect is proportional to the pressure applied on the lever and to the type of terrain and its snow coverage.

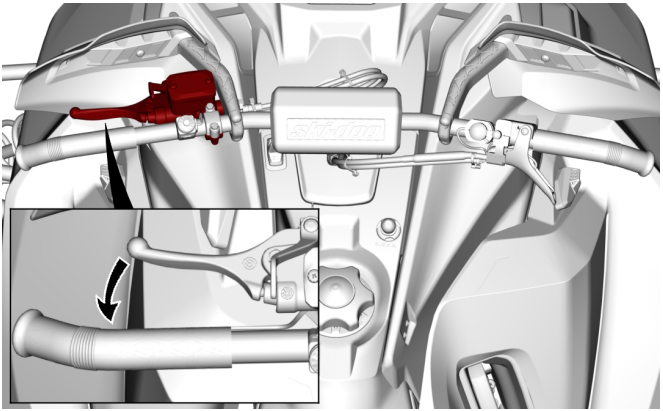

Parking Brake Lever

Parking brake lever is located on the LH side of handlebar.

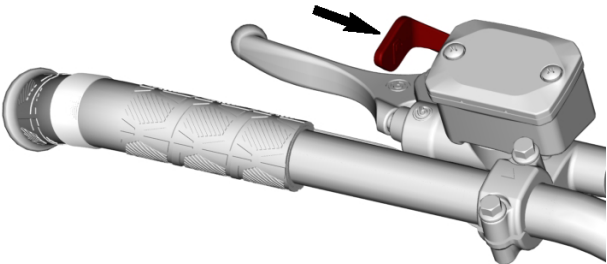

TYPICAL

Parking brake should be used whenever snowmobile is parked.

⚠ WARNING

Make sure parking brake is fully disengaged before operating the snowmobile. When you ride the vehicle, brake pads that are caused to drag by a continuous pressure on the lever may cause damage to the brake system and cause loss of braking capacity and/or fire.

To Engage Parking Brake

Apply and hold brake, then lock brake lever using the parking brake lever as shown.

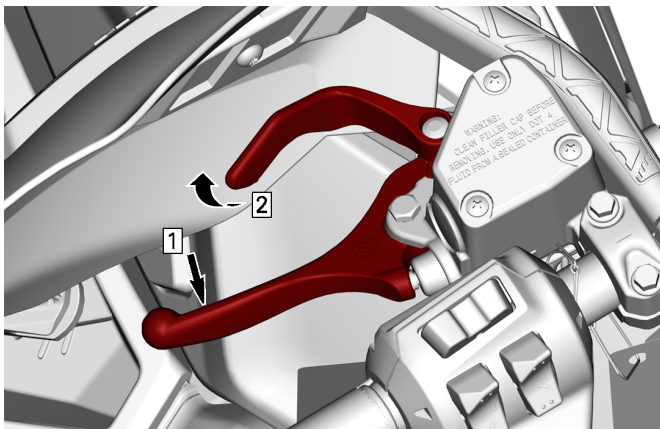

TYPICAL — ENGAGE MECHANISM

1. Apply and hold brake
2. Lock brake lever using parking brake lever

To Release Parking Brake

Squeeze brake lever. Parking brake lever will automatically return to its original position. Always release parking brake before riding.

Engine Cut-off Switch

The engine cut-off switch (tether cord) is located on the console.

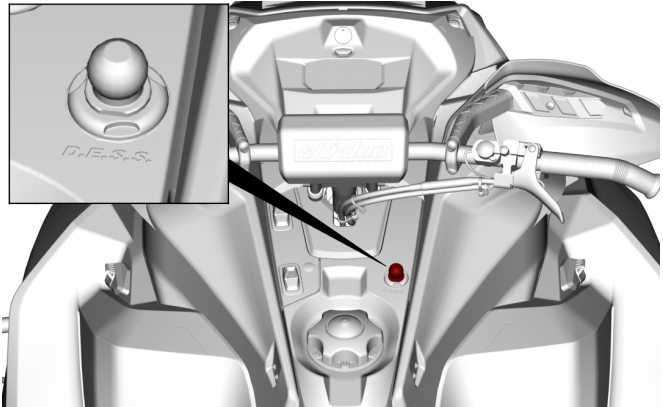

The tether cord cap must be securely snapped on the engine cut-off switch to allow vehicle operation.

Pulling the tether cord cap from the switch shuts the engine off.

WARNING

Always attach the tether cord eyelet to clothing before starting the engine.

NOTE:

The D.E.S.S. (Digitally Encoded Security System) can be enabled if desired. Contact an authorized Ski-Doo dealer.

D.E.S.S. (Digitally Encoded Security System)

The tether cord cap has an integrated D.E.S.S. key to provide you and your snowmobile with the equivalent security of a conventional lock key.

The D.E.S.S. key contains an electronic chip which features a unique permanently memorized digital code.

Your authorized BRP snowmobile dealer has programmed the D.E.S.S. of your snowmobile to recognize the D.E.S.S. key in the tether cord cap to allow vehicle operation.

If another tether cord is used without programming the D.E.S.S., the engine will start but will not reach drive pulley engagement speed to move vehicle.

Make sure the tether cord cap is free of dirt or snow.

D.E.S.S. Flexibility

The D.E.S.S. of your snowmobile can be programmed by your authorized BRP snowmobile dealer to accept up to 8 different keys.

We recommend the purchase of additional tether cords from your authorized BRP snowmobile dealer. If you have more than one D.E.S.S. equipped BRP snowmobile, each can be programmed by your authorized BRP snowmobile dealer to accept the other vehicles D.E.S.S. keys.

SECONDARY CONTROLS

Some features may not apply to your model or could be optional.

Vehicle safety labels are not shown on illustrations. For information on vehicle safety labels, refer to *Vehicle Safety Labels*.

Rewind Starter Handle

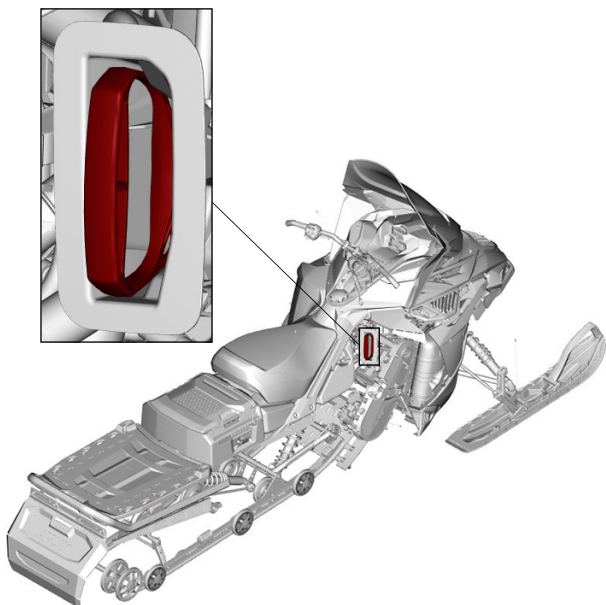

Auto-rewind type located on right hand side of snowmobile under the side panel. Open right hand side panel to access the rewind starter handle. Refer to *Removing the Side Panels* in this subsection. To engage mechanism pull handle slowly until a resistance is felt then pull vigorously. Slowly release handle.

NOTE:

The maximum torque that can be transmitted to the engine by the rewind starter is 80 Nm (59 lbf-ft). The maximum force that can be exerted on the on the rope is 2 200 N (494.6 lbf).

Exhaust Tuned Pipe Preheat Button

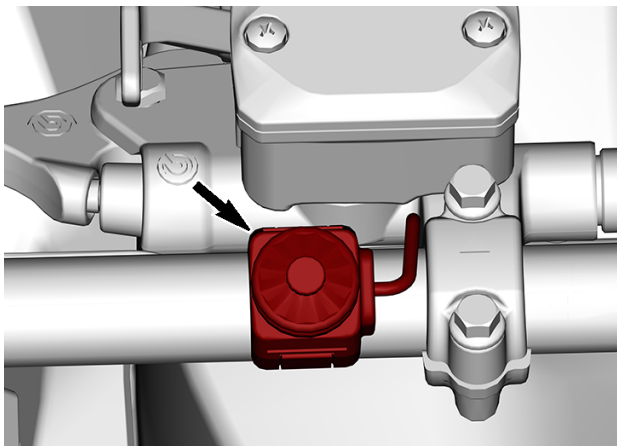

1. Preheat button

To preheat the exhaust tuned pipe:

1. Apply the parking brake.
2. Start the engine.
3. Completely release the throttle
4. Push and hold the preheat button and slowly start to press on the throttle lever.

The engine sound will change. Stuttering and backfire will then start.

5. Find the throttle position where there is a minimum of backfire.

The engine will cycle between stuttering and the rev limiter once the optimal temperature is reached.

6. Release the preheat button.

Headlights Dimmer Button

Press to select HI or LOW beam. Lights are automatically ON when the engine is running.

Heated Grips and Heated Throttle Lever Switch

NOTE:

- Under 2000 RPM, heated grips will be limited at 50%.
- Battery level will limit heated grips. Under 13 V the heated grips will be turned off.

NOTE:

Battery level will limit heated grips. Under 13 V the heated grips will be turned off.

The switch on the console controls simultaneously the handlebar grips and the throttle lever heat intensity.

The balance between the temperature of the throttle lever and the grips can be adjusted.

Depress switch as required to select heating intensity to keep your hands at a comfortable temperature.

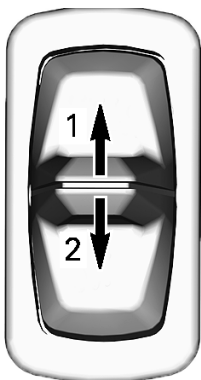

SWITCH ON CONSOLE

1. *Increase heat*
2. *Decrease heat*

The heating intensity is displayed via the digital display.



HEATED GRIPS DISPLAY

1. LH bar gauge



HEATED THROTTLE LEVER DISPLAY

1. RH bar gauge

Heated grips and throttle lever will be OFF when there are no bars displayed on the gauge.

When the switch is released, display will return to fuel level and engine temperature.

BODY

Front and Rear Bumpers

To be used whenever snowmobile requires manual lifting.

CAUTION

Beware of injuries by using proper lifting techniques, notably by using the force of your legs. Do not attempt to lift the rear of vehicle if it is above your limits. Use appropriate lifting device or have assistance to share lifting stress if possible.

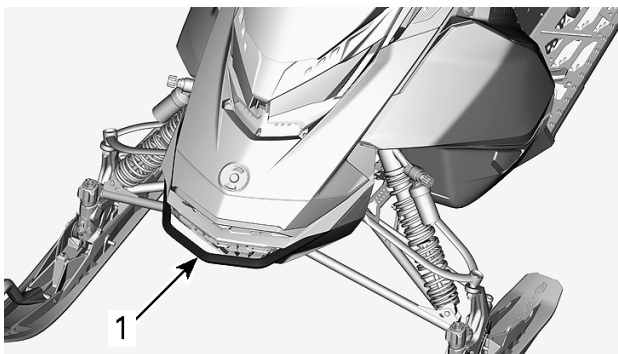

TYPICAL

1. Front bumper

NOTICE

Do not use skis to pull or lift snowmobile.

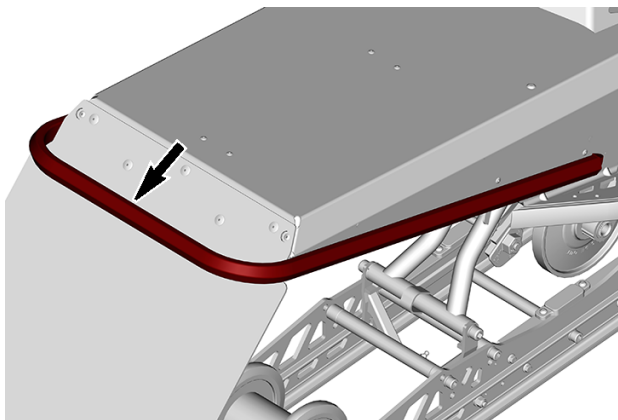

REAR BUMPER

Upper Body Module

Removing the Upper Body Module

1. Remove the gauge support screws.

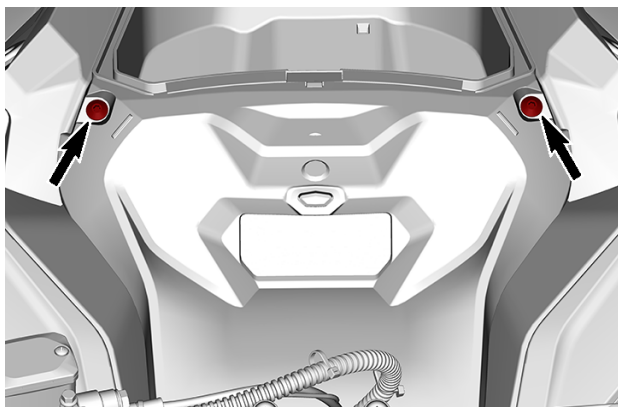

2. Lift the front of the gauge support, then slide it forward to remove it.

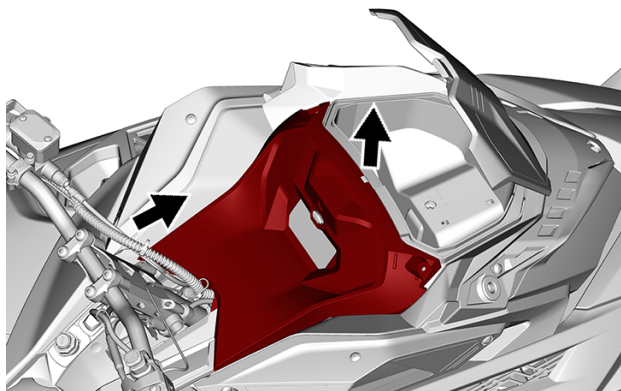
**TYPICAL**

3. Disconnect the gauge connector and remove the support.
4. Disconnect the headlight and the MAPTS connectors.

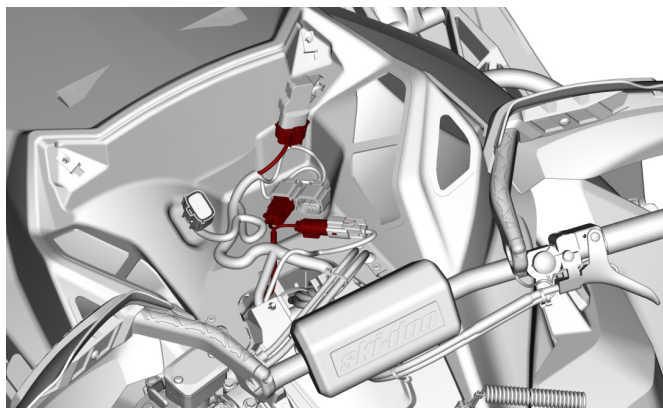

5. Remove both side panels. Refer to *Side Panels* in this section.
6. Loosen the air intake duct clamp.

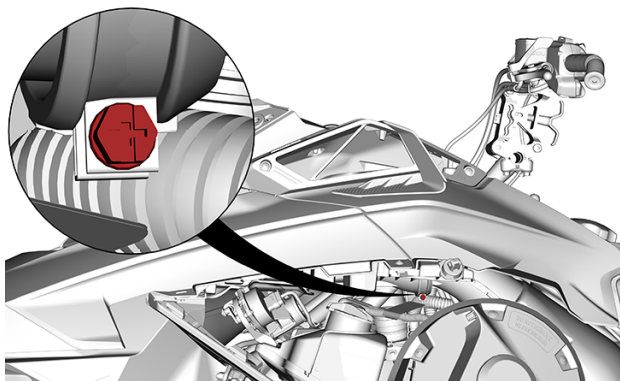

7. Remove the upper body module retaining screws on both sides.

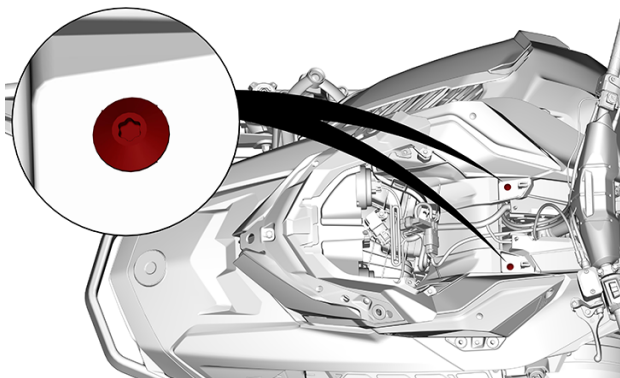

8. Remove the upper body module.

1. Grab the upper body module in the gauge support section.
2. Pull the module forward.
3. Remove the module from the vehicle.

Installing the Upper Body Module

1. Lower the upper body module on the vehicle.

NOTE:

Make sure the air intake duct is positioned properly connected.

2. Tighten air intake duct clamp.

TIGHTENING TORQUE	
Intake duct clamp	1.0 ± 0.2 Nm (9 ± 2 lbf-in)

3. Install and tighten the upper body module retaining screws.

TIGHTENING TORQUE	
Center upper body screws	1.8 ± 0.2 Nm (16 ± 2 lbf-in)

TIGHTENING TORQUE	
Front and rear upper body screws	1.3 ± 0.2 Nm (12 ± 2 lbf-in)

4. Connect the manifold air pressure and temperature sensor (MAPTS) connector.
5. Connect the headlight connectors.
6. Install gauge, secure with the screws.

TIGHTENING TORQUE	
Gauge support screws	2.3 ± 0.2 Nm (20 ± 2 lbf-in)

Side Panels

WARNING

Never operate engine with side panels opened or removed from vehicle.

Removing the Side Panels

1. Unlock all latches, then open panel.

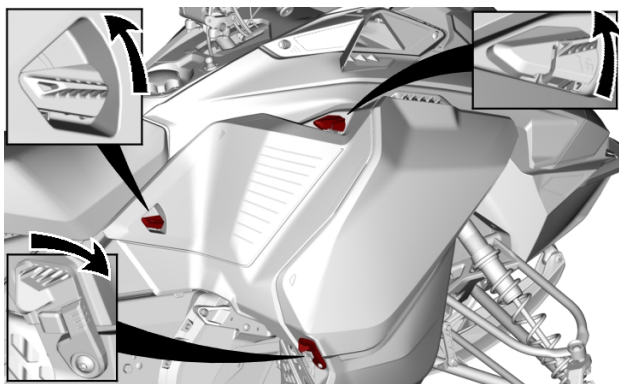

TYPICAL — 3 LATCHES

2. Pivot side panel around lower edge.

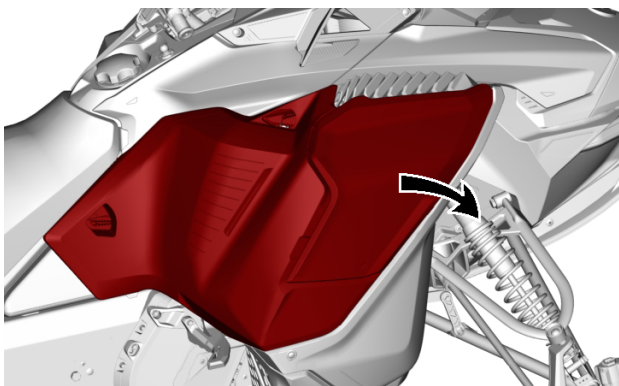

3. Slide the panel hinge off the bottom pan.

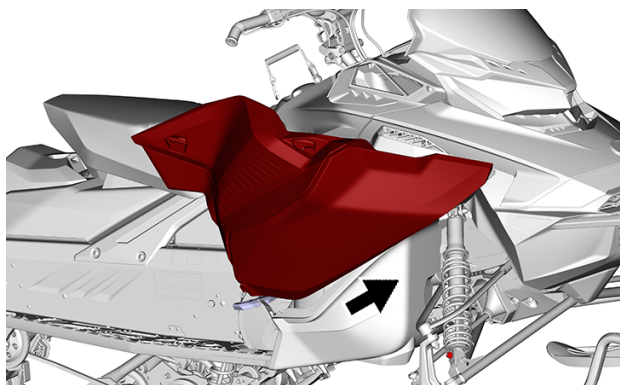

NOTICE

Make sure to place panel in a safe place to avoid scratching.

Installing the Side Panels

The installation is the reverse of the removal procedure. Make sure the bottom panel tab is inserted in the side bottom pan during installation. If not, side bottom pan will be scratched and panel tab can get damaged

EQUIPMENT

Some features may not apply to your model or could be optional.

Drive Belt Guard

Removing the Drive Belt Guard

⚠ WARNING

NEVER operate engine:

- Without shields and belt guard securely installed.
- With hood and/or side panels opened or removed.

NEVER attempt to make adjustments to moving parts while engine is running.

NOTE:

Belt guard is purposely made slightly oversize to maintain tension on its pins and retainers preventing undue noise and vibration. It is important that this tension be maintained when reinstalling.

Remove tether cord cap from engine cut-off switch.

Open the LH side panel. See procedure in this section.

Remove retaining pin.

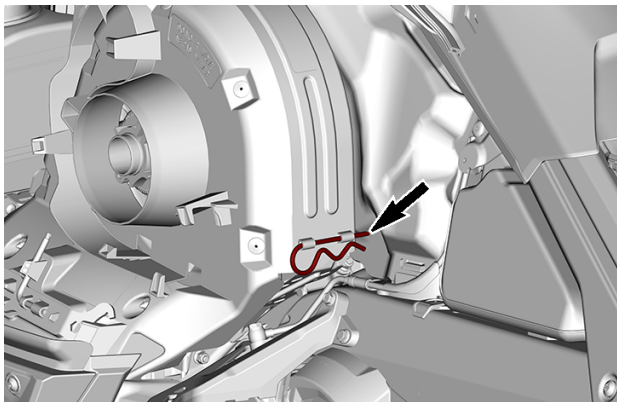

TYPICAL

Lift rear portion of guard then release from front tab.

Installing the Drive Belt Guard

Insert belt guard tab in front support slot.

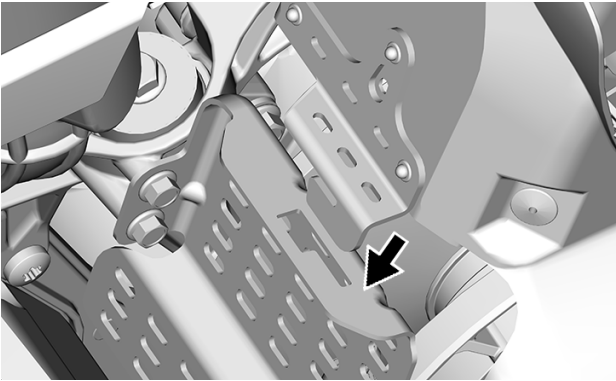

Push drive belt guard toward engine then toward front of vehicle.

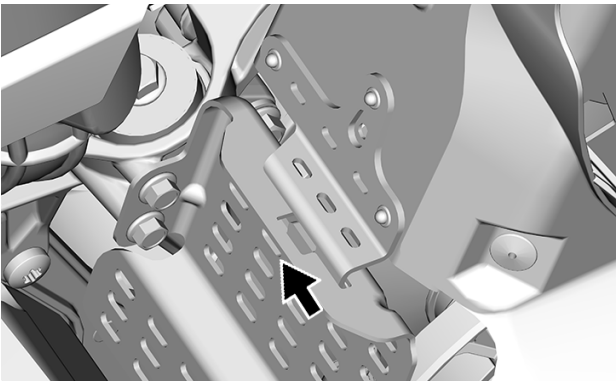

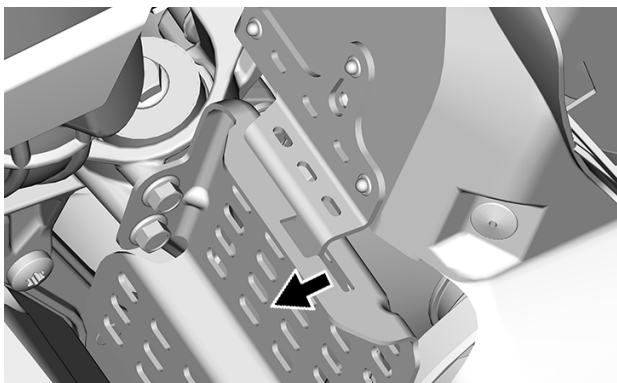

Position the rear portion of the belt guard over the retainer and secure it using the retaining pin.

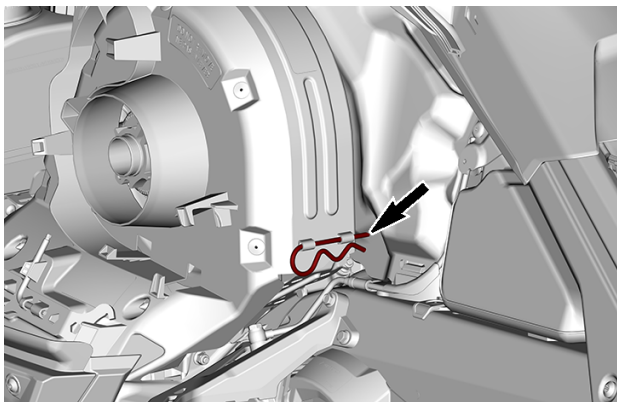

COMPACT DIGITAL DISPLAY



COMPACT DIGITAL DISPLAY

 **WARNING**

Reading the digital display can distract from the operation of the vehicle, particularly from constantly scanning the environment.

NOTE:

The digital display is factory preset in Imperial units and in English. To change units or language, contact an authorized BRP snowmobile dealer.

Display Features



COMPACT DIGITAL DISPLAY

1. Mode button
2. Digits
3. Icons
4. Bar gauges

The digital display also has a built-in beeper.

Digital Display

! WARNING

Never adjust or set functions on the digital display while riding the vehicle.

To set the displays to your preference, refer to *Display Combination Selection*.

Upper Display

The upper display is used to display:

- Vehicle speed.
- Engine speed (RPM).



1. Upper Display

Lower Display

The lower display is used to display

- Various information (in combination with the upper display)
- Messages, refer to *Icons and Messages and Monitoring System* for details.
- Fault codes, refer to *Monitoring System* for details.

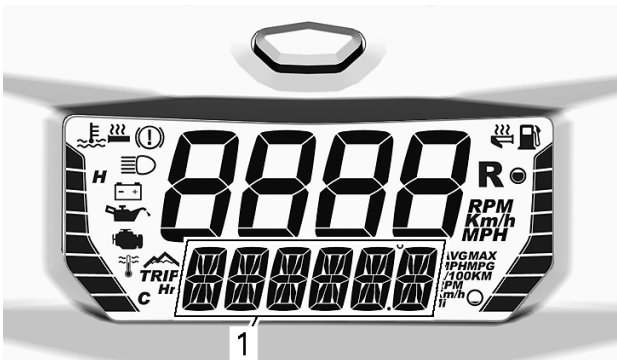

1. Lower display

LH side Bar Gauge



1. LH bar gauge

LH Bar Gauge Information

Engine coolant temperature

Heated grips level

The LH side bar gauge displays the engine coolant temperature except while adjusting the heating elements.

NOTICE

If engine overheats, stop vehicle in a safe place. Refer to TROUBLESHOOTING.

For details on heated grips operation, refer to *Heated Grips and Throttle Lever Switch* in *Secondary Controls*.

RH Side Bar Gauge



1. RH bar gauge

RH Bar Gauge Information

Fuel level

Heated throttle lever level

The RH side bar gauge displays the fuel level except while adjusting the heated throttle lever.

For details on heated throttle lever operation, refer to *Heated Grips and Throttle Lever Switch* in *Secondary Controls*.

Display Combination Selection

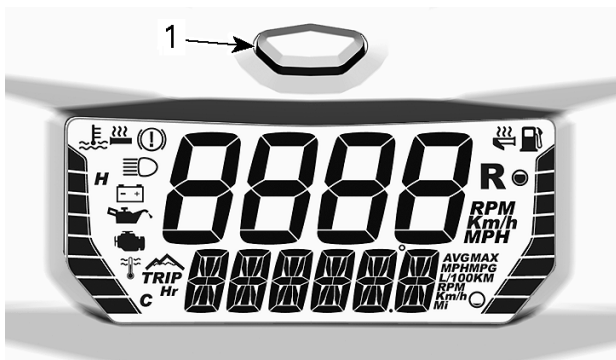

The upper and lower displays can be set as combination only. They cannot be set separately.

To scroll through the information options, press and release the mode button repeatedly until the desired information is displayed.



1. Gauge mode button

refer to the following table for available combinations.

Available Display Combinations				
	Upper Display	Icon/ Specific information	Lower Display	Icon/ Specific information
1	Vehicle speed OR Engine RPM	Km/h or MPH OR RPM	Vehicle speed OR Engine speed	Km/h or MPH OR RPM
	Engine RPM	RPM	Altitude	 M or F
2	Vehicle speed	Km/h or MPH	Altitude	 M or F
3			Odometer	Km or MI
			Trip odometer A(1)	TRIP Km or MI
4			Trip odometer B (1) (2)	TRIP Km or MI
5				
6			Trip hour (1)	TRIP Hr
	Top speed (1)	MAX		

7				Km/h or MPH
8			Average speed (1)	AVG Km/h or MPH
9			Top RPM (1)	MAX RPM
10	Vehicle speed	Km/h or MPH	Average fuel consumption	AVG L/100Km or MPG
11				
12			Engine coolant temperature	E and C or F
(1) Press and hold the mode button to reset (2) Resetting the trip odometer B also resets the average fuel consumption				



NOTE:

Make sure to display the vehicle speed whenever this information is necessary.

Icons and Messages

See table below for usual icons and messages.

For details on malfunction pilot lamps and messages, refer to *Monitoring System*.

Icon	Beeper	Message Lower Display	Description
—	2 short beeps	GOOD KEY	At power up, with a good key. Vehicle ready for use.
—	—	BREAK-IN	Displayed during break-in period. Refer to <i>Break-in Period</i>
	4 short beeps every 5 minutes	LOW OIL	Injection oil level is low. Stop vehicle in a safe place then, replenish injection oil reservoir.
 (blinking)	—	—	Low fuel level. No bar left in fuel level display. Replenish fuel tank as soon as possible.
	Long beeps repeating slowly	REVERSE	Reverse is selected.
	3 short beeps	REV. FAIL	Reverse did not engage, try again.

Icon	Beeper	Message Lower Display	Description
	—	—	High beam headlights are selected.
—	—	WARM UP	Engine and/or injection oil need to warm-up before normal operation. The engine's RPM is limited until desired temperature is reached (up to 10 minutes when driving). Warm-up period may occur after a restart in very cold weather.

FUEL AND OIL

Fuel Requirements

NOTICE

Always use fresh gasoline/oil mix. Gasoline will oxidize; the result is loss of octane, volatile compounds, and the production of gum and varnish deposits which can damage the fuel system. Mix the appropriate oil with the gasoline in the recommended ratio.

Alcohol fuel blending varies by country and region. Your vehicle has been designed to operate using the recommended fuels, however, be aware of the following:

- Use of fuel containing alcohol above the percentage specified by government regulations is not recommended and can result in the following problems in the fuel system components:
 - Starting and operating difficulties.
 - Deterioration of rubber or plastic parts.
 - Corrosion of metal parts.
 - Damage to internal engine parts.
- Inspect frequently for the presence of fuel leaks or other fuel system abnormalities if you suspect the presence of alcohol in gasoline exceeds the current government regulations.
- Alcohol blended fuels attract and hold moisture which may lead to fuel phase separation and can result in engine performance problems or engine damage.

Recommended Fuel

The gasoline must have the following minimum octane requirements.

Use unleaded gasoline containing **MAXIMUM 10% ethanol.**

Fuel type	Min. octane rating
Fuel with NO ethanol	91 AKI (RON+MON)/2 95 RON
Fuel which may contain up to 10% MAX ethanol	91 AKI (RON+MON)/2 95 RON 

NOTICE

Never experiment with other fuels. Engine or fuel system damages may occur with the use of an inadequate fuel.

NOTICE

Do NOT use fuel from fuel pumps labeled E85.

Use of fuel labeled E15 is prohibited by U.S. EPA Regulations.

Pre-Mix Oil

This vehicle has no injection oil pump.

The oil must be thoroughly mixed with gasoline in an approved fuel container first, then be poured in the vehicle fuel tank.

Pre-mix Fuel/Oil Ratio

Proper ratio of 33:1

16.5L of fuel + 500ml of oil

5 U.S. gallon of fuel + 19.4 U.S. ounce of oil

5 imperial gallon of fuel + 24.2 imperial ounce of oil

Recommended Pre-mix Oil

Recommended Premix Oil

XPS 2T X2-RS racing synthetic oil

NOTICE

The engine was developed and validated using the 2T X2-RS Synthetic Racing Engine Oil. BRP strongly recommends the use of this oil at all times. Never experiment other fuel/oil ratios. Damages caused by using oil not suitable for the engine or incorrect fuel/oil ratio will not be covered by the BRP limited warranty.

Fueling Procedure

 **WARNING**

Always stop engine before refueling.

 **WARNING**

Fuel is flammable and explosive under certain conditions.
Never use an open flame to check fuel level.
Never smoke or allow flame or spark in vicinity.
Always work in a well-ventilated area.

NOTE:

Do not sit or lean on seat when fuel tank cap is not properly installed.

1. Stop engine.
2. Have operator and passenger get off vehicle.

 **WARNING**

Do not allow anyone seated on the vehicle while fueling.

3. Unscrew slowly the fuel reservoir cap counterclockwise to stabilize pressure before removing it.

NOTE:

A short whistling sound is normal.

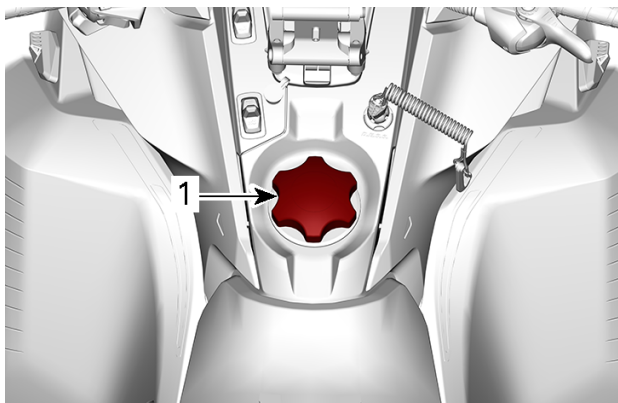

TYPICAL

1. Fuel tank cap

4. Insert the spout into the filler neck.
5. Pour fuel slowly so that air can escape from the tank and prevent fuel flow back. Be careful not to spill fuel.
6. Stop filling when the fuel reaches the bottom of filler neck. **Do not overfill.**

! WARNING

Never top up the fuel tank before placing the vehicle in a warm area. As temperature increases, fuel expands and may overflow.

7. Fully tighten fuel reservoir cap clockwise.

! WARNING

Always wipe off any small fuel spillage from the vehicle. If a major spillage occurs, remove side panels to remove fuel vapors from engine compartment before starting.

NOTE:

Do not sit or lean on seat when fuel tank cap is not properly installed.

BREAK-IN PERIOD

Operation During Break-In

Engine

During the break-in period:

- Avoid prolonged full throttle operation.
- Avoid sustained accelerations.
- Avoid prolonged cruising speeds.
- Avoid engine overheating.

However, brief accelerations and speed variations contribute to a good break-in.

During a predetermined period, the engine management system controls some engine parameters.

The duration is based on fuel volume. It will take approximately two fuel tanks to complete the break-in.

During this period:

- The engine performance and behavior will not be optimal.
- The fuel and oil consumption will be higher.

Also, during the first hours of operation, monitor the level in the water pump shaft oil reservoir. It is normal that it lowers a little. However, it should stabilize after a moment, and then remain stable over time.

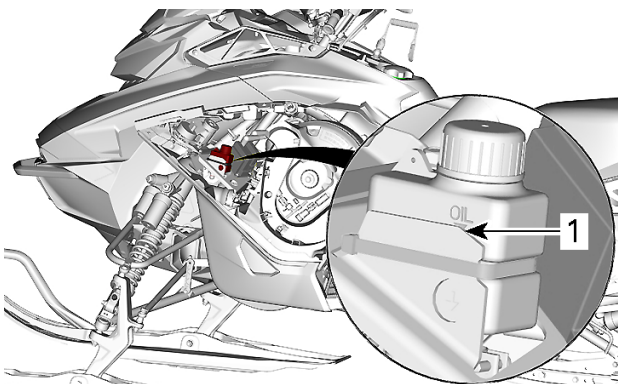

1. Normal oil level

Drive Belt

A new drive belt requires a break in period of 50 km (30 mi).

BREAK-IN PERIOD

During the break-in period:

- Avoid strong acceleration and deceleration.
- Avoid pulling a load.
- Avoid high speed cruising.

If the vehicle creeps, lower the drive belt height from the preliminary setting. Refer to *Drive Belt* in *maintenance procedure*.

BASIC PROCEDURES

Engine Starting Procedure

Procedure

1. Apply parking brake.
2. Recheck throttle control lever operation.
3. Put your helmet on.
4. Ensure that the tether cord cap is installed on the engine cut-off switch and that the cord is attached to your clothing eyelet.
5. Ensure that the emergency engine stop switch is in the ON position (up).



WARNING

Never depress throttle while starting engine.

6. Release parking brake.

NOTE:

For an initial cold start, do not release parking brake. Perform the *vehicle warm-up* procedure as explained below.

7. Grab rewind starter handle, pull handle slowly until a resistance is felt, then hold handle firmly and pull vigorously to start engine.

NOTE:

The maximum torque that can be transmitted to the engine by the rewind starter is 80 Nm (59 lbf-ft). The maximum force that can be exerted on the rope is 2 200 N (494.6 lbf).

Vehicle Warm-Up

Before every ride, vehicle has to be warmed up as follows.

1. Start engine as explained in *Engine Starting Procedure* above.
2. Allow engine to warm up one or two minutes at idle speed.

NOTE:

Engine will shut down after approximately 12 minutes of idling.

3. Disengage parking brake.
4. Apply throttle until drive pulley engages. Drive at low speed the first two or three minutes.

NOTICE

If vehicle does not move when throttle is applied, stop engine, remove tether cord cap from the engine cut-off switch, then do the following.

- Check if skis are stuck on the ground. Lift one ski at a time by the handle, then put it down.
- Check if track is stuck on the ground. Lift rear of snowmobile enough to clear track from the ground, then drop.
- Check rear suspension for hard snow or ice accumulation that could interfere with track rotation. Clean the area.

CAUTION

Beware of injuries by using proper lifting techniques, notably using your legs force. Do not attempt to lift the rear of vehicle if it is above your limits.

WARNING

Make sure tether cord cap is removed before standing in front the vehicle, getting close to the track or rear suspension components.

NOTE:

Warm-up is electronically controlled. During this period (up to 10 minutes depending on ambient temperature), engine RPM is limited.

Shutting Off the Engine

Release throttle lever and wait until engine has returned to idle speed.

Shut off the engine using either the emergency engine stop switch or by pulling off the tether cord cap from the engine cut-off switch.

WARNING

Always remove the tether cord cap from engine cut-off switch when vehicle is not in operation in order to prevent accidental engine starting or to avoid unauthorized use by children or others or theft.

After engine shutdown:

The fan may remain active between 1 and 4 minutes after the shut-down depending on the exhaust temperature.

RIDING CONDITIONS AND YOUR SNOWMOBILE

Altitude

At factory, your snowmobile was calibrated to be used within an altitude range (relative to sea level).

A new snowmobile has a tag attached to the handlebar indicating its calibration. Refer to *Safety Information on Vehicle*.

If for any reason you don't know your snowmobile calibration, contact an authorized BRP snowmobile dealer.

If your snowmobile is to be used at an altitude outside the specified range, have it calibrated accordingly by an authorized BRP snowmobile dealer.

NOTICE

An inappropriate altitude calibration would decrease performance and may cause serious damage to the snowmobile.

Temperature

The engine management of these engines provides the optimum air/fuel ratio for all temperatures.

Hard Packed Snow

All models covered in this guide which are equipped with a minimum track profile of 44 mm (1.75 in) are built for deep snow conditions and should never be used during a prolonged period of time in marginal or hard packed snow conditions.

In the event you have to ride in these types of conditions:

- Avoid exceeding a speed of 70 km/h (45 mph) in all conditions
- Avoid hard acceleration (over 75% of throttle)
- Ice scratchers should be applied
- Engine temperature should not exceed 75% on the temperature gauge.

NOTICE

Running these types of tracks at high speed on a trail, on hard packed surfaces or on ice puts more stress on the lugs, which tends to heat up as a result. It also could drastically reduce the life of specific wear parts. To avoid potential degradation, delamination or damages to the track and wear parts, reduce your speed and minimize the distance that is being ridden on these types of surfaces.

Vehicles Equipped with Ice Scratchers

Ice scratchers are equipped on the vehicle to increase engine cooling efficiency, to lubricate and to cool track clips and sliders. They must be used whenever on ice, hard packed snow, or any conditions that do not lift enough snow particles into the rear suspension and the tunnel.

NOTICE

Although it is not recommended to ride a snowmobile equipped with a high lug profile track on trails or hard packed snow conditions, it is highly suggested to combine idler wheels and ice scratchers on a vehicle used in these conditions.

IMPORTANT

Ridding in these trail conditions puts the reliability of the track and its warranty at risk

If equipped with the following track profile heights, never exceed the recommended sustained vehicle speeds listed.

Track Profile Height	Maximum Sustained Speed
57 mm (2.25 in) 60 mm (2.36 in)	110 km/h (70 MPH)
64 mm (2.52 in) 75 mm (3 in)	95 km/h (60 MPH)

TUNE YOUR RIDE

Snowmobile handling and comfort depend upon multiple adjustments.

WARNING

Suspension adjustment could affect vehicle handling. Always take time to familiarize yourself with the vehicle's behavior after any suspension adjustment have been made. Always adjust LH and RH suspension components to the same setting.

Choice of suspension adjustments vary with carrying load, operator's weight, personal preference, riding speed and field condition.

NOTE:

Some adjustments may not apply to your snowmobile.

WARNING

Before proceeding with any suspension adjustment, remember:

- Park in a safe place.
- Remove the tether cord cap from the engine cut-off switch.
- Use appropriate lifting device or have assistance to share lifting stress. If a lifting device is not used, use proper lifting techniques, notably using your legs force.
- Do not attempt to lift the front or rear of vehicle if it is above your limits.
- Support front of vehicle off the ground with a suitable device before adjusting suspension.
- Support rear of vehicle off the ground with a wide-base snowmobile stand with a rear deflector panel.
- Make sure support device is stable and secure.

The best way to set up the suspension is to customize each adjustment one at a time. Various adjustments are interrelated. It may be necessary to readjust center spring after adjusting front springs for instance. Test run the snowmobile under the same conditions; trail, speed, snow, operator riding position, etc. Proceed methodically until you are satisfied.

Following are guidelines to fine-tune suspension. Use suspension adjustment tool provided in the tool kit.

Front Suspension Adjustments

Front Springs

Front spring preload has an effect on front suspension firmness.

Front spring preload also has an effect on the steering behavior.

Action	Result
Increasing preload	Firmer front suspension
	Higher front end
	More precise steering
	More bump absorption capability
Decreasing preload	Softer front suspension
	Lower front end
	Lighter steering
	Less bump absorption capability

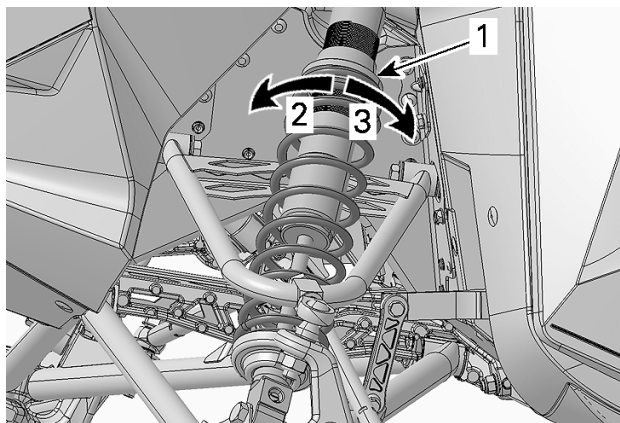
**TYPICAL**

1. Spring preload adjustment ring
2. Increase preload
3. Decrease preload

NOTICE

Make sure that both front springs are still pre-loaded when front of vehicle is off the ground.

Shock Absorber Damping**ADJUSTMENT SCREWS**

1. High speed rebound - Red screw
2. High speed compression - Blue screw
3. Low speed compression - Grey screw
4. Bypass screw

Low Speed Compression Damping (Grey Screw)

Low speed compression damping controls how the shock absorber reacts to a low suspension velocity (slow compression strokes, in most cases when riding at lower speeds).

Action	Result
Increasing low speed compression damping force	Firmer compression damping (slow compression)
Decreasing low speed compression damping force	Softer compression damping (slow compression)

To adjust, turn clockwise to increase damping force and counterclockwise to decrease damping force.

High Speed Compression Damping

High speed compression damping controls how the shock absorber reacts to a high suspension velocity (quick compression strokes, in most cases when riding at higher speeds).

Action	Result
Increasing high speed compression damping force	Firmer compression damping (fast compression)
Decreasing high speed compression damping force	Softer compression damping (fast compression)

To adjust, turn clockwise to increase damping force and counterclockwise to decrease damping force.

High Speed Rebound Damping (Red screw)

High speed rebound damping controls how the shock absorber reacts when moving in extension. The effect will be felt mostly on how reactive the suspension is to bumps and quick changes in forces. This will also affect how fast the shock extends.

Action	Result
Increasing high speed rebound damping force	Reduce the speed in extension of the suspension. The suspension will react slower thus comply with less of the bumps on the ground.
Decreasing high speed rebound damping force	Let the suspension move quicker in extension helping it to follow most of the ground bumps.

To adjust, turn clockwise to increase damping force and counterclockwise to decrease damping force.

Bypass Adjustment

The bypass controls how much oil can go around the valving of the shock absorber. This reduces the damping force and softens the ride.

Action	Result
Increasing bypass	Reduce the damping force both in compression and rebound, giving a smoother ride.
Decreasing bypass	Raise the damping force in both compression and rebound. The suspension can absorb bigger impacts.

To adjust, turn clockwise to decrease bypass and counterclockwise to increase bypass.

Rear Suspension Adjustments

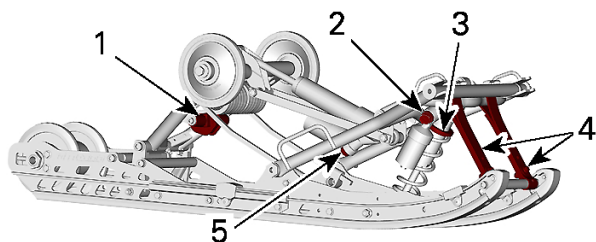

ADJUSTABLE COMPONENTS

1. *Rear spring preload*
2. *Center shock absorber damping*
3. *Center spring preload*
4. *Stopper straps*
5. *Rear shock absorber damping*

NOTICE

Whenever adjusting rear suspension, check track tension and adjust if necessary.

Stopper Strap

Stopper strap length has an effect on the amount of weight the center spring has to carry especially during acceleration, therefore on the front end uplift.

Stopper straps length also has an effect on center spring travel.

NOTICE

Whenever stopper strap length is changed, track tension must be checked.

Action	Result
Increasing stopper strap length	Lighter ski pressure under acceleration
	More center spring travel
	More bump absorption capability
Decreasing stopper strap length	Heavier ski pressure under acceleration
	Less center spring travel
	Less bump absorption capability

NOTE:

Stopper strap could be set to position 1, 2, 3, 4 and 5. Below are illustrations for position 1 and 3. Smaller numbers correspond to a longer strap setting.

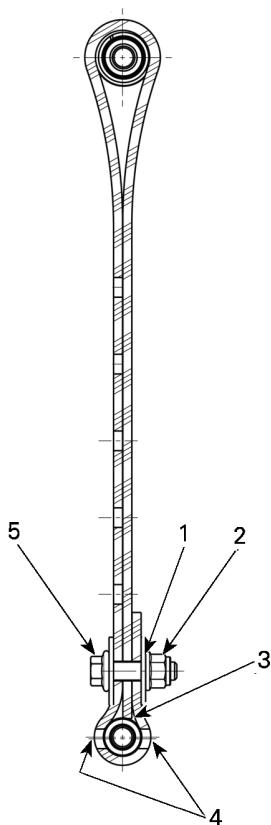

STOPPER STRAP POSITION 1 (1ST HOLE, LONGEST) – FACTORY SETTING

1. 1st hole from end
2. Towards rear
3. Tip of strap touching strap axis
4. Two holes left open between screw head and nut
5. Towards front

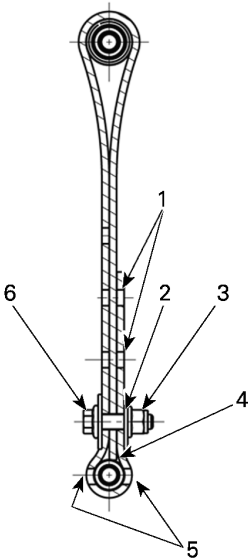

STOPPER STRAP POSITION 3 (3RD HOLE)

1. Free holes
2. 3rd hole from end
3. Towards rear
4. Tip of strap touching strap axis
5. Two holes left open between screw head and nut
6. Towards front

NOTE:

Decreasing the stopper strap length may reduce comfort. If too much weight transfer is felt, try to correct it by adjusting the coupling shaft first. Always install stopper strap bolt as close as possible to the lower shaft.

When operating the snowmobile in deep snow, it may be necessary to vary stopper strap length and/or riding position, to change the angle at which the track rides on the snow. Operator's familiarity with the various adjustments as well as snow conditions will dictate the most efficient combination.

Generally, a longer stopper strap setting gives better performance in deep snow on a flat landscape.

Adjusting the Stopper Strap using the Eccentric Limit Axle

The stopper straps are mounted on an eccentric type limit axle that allow precise adjustment of up to 10 mm (3/8 in).

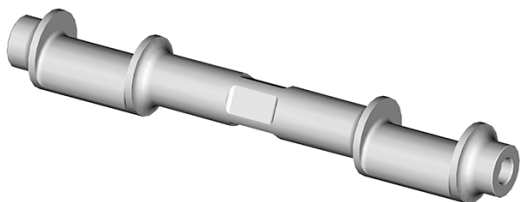

1. Slightly loosen the screws on each side.

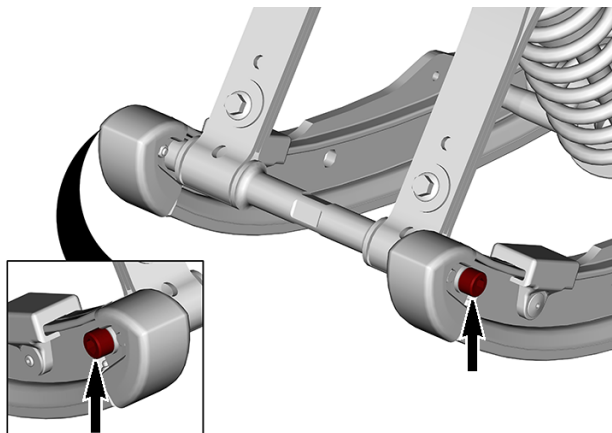

2. Rotate the axle to the desired position.

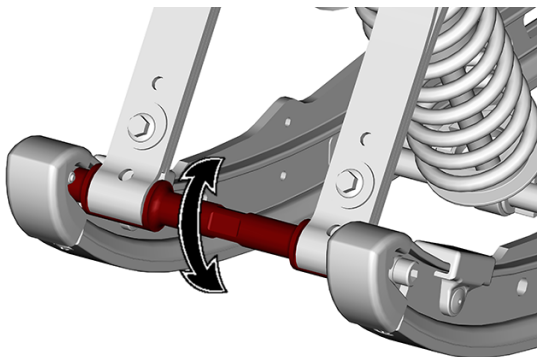

3. Tighten the axle screws to specification.

Tightening Torque	
Axle screw	48 ± 6 Nm (35 ± 4 lbf-ft)

Center Spring

Center spring preload has an effect on steering effort, handling and bump absorption.

Also, since center spring preload adjustment puts more or less pressure on the front of the track, it has an effect on the performance in deep snow.

Action	Result
Increasing preload	Lighter steering
	More bump absorption capability
	Better deep snow starts
	Better deep snow performance and handling

Action	Result
Decreasing preload	Heavier steering
	Less bump absorption capability
	Better trail handling

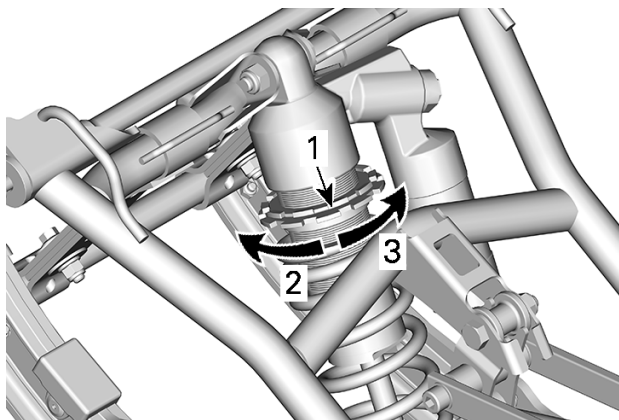

TYPICAL

1. Spring preload adjustment ring
2. Increase preload
3. Decrease preload

NOTE:

Use the suspension adjustment tool provided in the tool kit.

Rear Spring

Rear spring preload has an effect on comfort, ride height and load compensation.

Also, adjusting rear spring preload shifts more or less weight to the snowmobile front end. As a result, more or less weight is applied to the skis. This has an effect on performance in deep snow, steering effort and handling.

Slight suspension bottoming occurring under the worst riding conditions indicates a good choice of spring preload.

Action	Result
Increasing preload	Firmer rear suspension
	Higher rear end
	More bump absorption capability
	Heavier steering
Decreasing preload	Softer rear suspension
	Lower rear end
	Less bump absorption capability
	Lighter steering
	Better performance and handling in deep snow

NOTE:

If the specification is unattainable with the original springs, see an authorized Ski-Doo dealer for other available springs.

rMotion - without Quick Adjust

To increase spring preload using tool, always turn the left side adjustment cam in a clockwise direction, and the right side cam in a counter-clockwise direction.

**CAUTION**

Never set preload cams directly from position 5 to 1 or directly from position 1 to 5.

⚠ WARNING

Both rear spring preload must be set at the same position. Otherwise vehicle behavior may be unpredictable, and suspension may become warped.

The adjustment cams have 5 different settings, 1 being the softest.

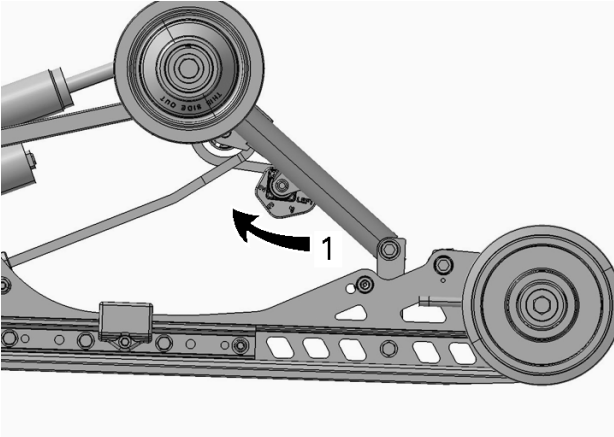

TYPICAL - LH SIDE

1. Adjust spring preload

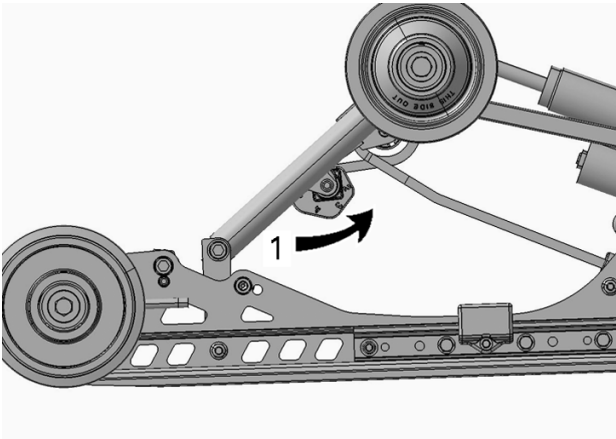

TYPICAL - RH SIDE

1. Adjust spring preload

Shock Absorber Damping



ADJUSTMENT SCREWS

1. High speed rebound - Red screw
2. High speed compression - Blue screw
3. Low speed compression - Grey screw
4. Bypass screw - Rear shock only

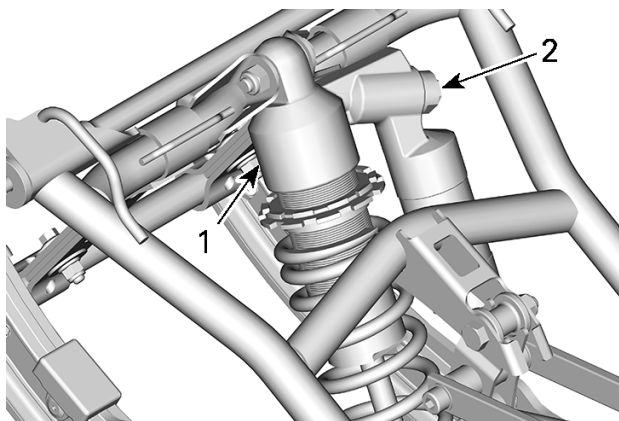

TYPICAL FRONT SHOCK ABSORBER

1. Front shock absorber
2. Adjustment screws

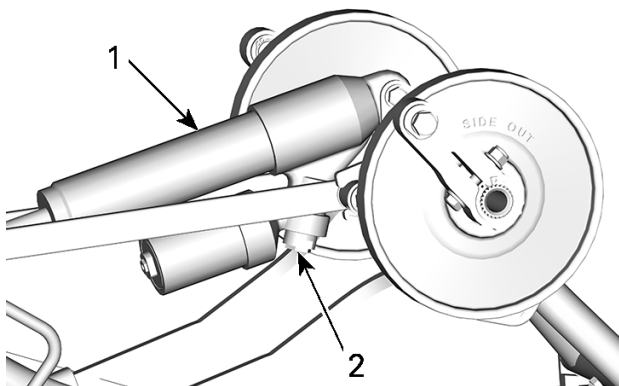

TYPICAL REAR SHOCK ABSORBER

1. Rear shock absorber
2. Adjustment screws

Low Speed Compression Damping (Grey screw)

Low speed compression damping controls how the shock absorber reacts to a low suspension velocity (slow compression strokes, in most cases when riding at lower speeds).

Action	Result on big bumps
Increasing low speed compression damping force	Firmer compression damping (slow compression)
Decreasing low speed compression damping force	Softer compression damping (slow compression)

To adjust, turn clockwise to increase damping force and counterclockwise to decrease damping force.

High Speed Compression Damping (Blue screw)

High speed compression damping controls how the shock absorber reacts to a high suspension velocity (quick compression strokes, in most cases when riding at higher speeds).

Action	Result on small bumps
Increasing high speed compression damping force	Firmer compression damping (fast compression)
Decreasing high speed compression damping force	Softer compression damping (fast compression)

To adjust, turn clockwise to increase damping force and counterclockwise to decrease damping force.

High Speed Rebound Damping (Red screw)

High speed rebound damping controls how the shock absorber reacts when moving in extension. The effect will be felt mostly on how reactive the suspension is to bumps and quick changes in forces. This will also affect how fast the shock extends.

Action	Result
Increasing high speed rebound damping force	Reduce the speed in extension of the suspension. The suspension will react slower thus comply with less of the bumps on the ground.
Decreasing high speed rebound damping force	Let the suspension move quicker in extension helping it to follow most of the ground bumps.

To adjust, turn clockwise to increase damping force and counterclockwise to decrease damping force.

Bypass Adjustment (Rear Shock)

The bypass controls how much oil can go around the valving of the shock absorber. This reduces the damping force and softens the ride.

Action	Result
Increasing bypass	Reduce the damping force both in compression and rebound, giving a smoother ride.
Decreasing bypass	Raise the damping force in both compression and rebound. The suspension can absorb bigger impacts.

To adjust, turn clockwise to decrease bypass and counterclockwise to increase bypass.

Holeshot Device

The holeshot device is a suspension pre-loading device designed to provide a faster and more effective way to transfer power to the ground.

The red button is mounted on right side of the rear suspension.

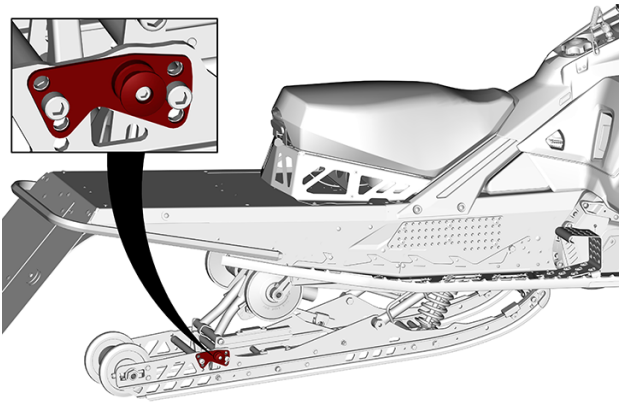

By compressing the suspension, more force is needed to initiate its movement. This results in a faster weight transfer, which helps putting the power to the ground quicker.

Activating the Holseshot Device

1. Position the vehicle on the starting line, aligned and ready to go. Jumping on the footboard or bouncing on the seat to settle the track, if performed, should be done now.

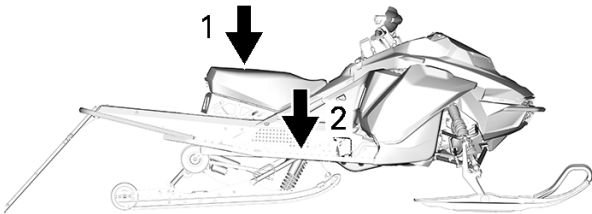

1. *Bounce on the seat*
2. *Jump on the footboard*

2. Lower the tunnel by compressing the suspension enough that the holeshot button can FULLY be pushed in.

NOTE: Having a helper to activate the holeshot device is strongly suggested.

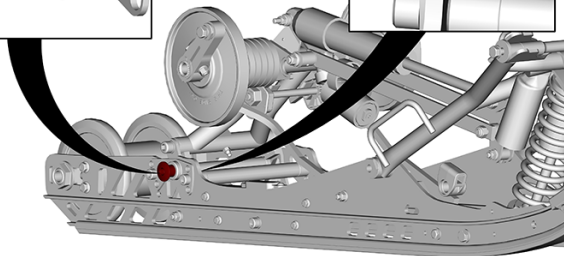
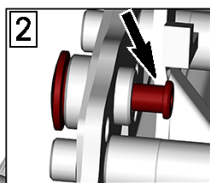
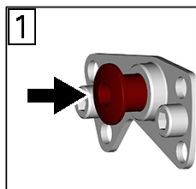
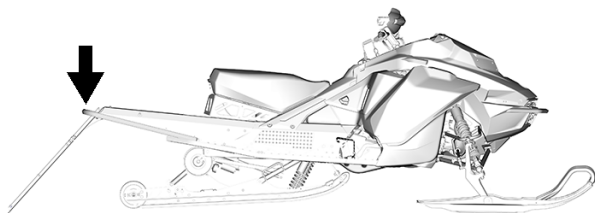

Step 1. Push the button

Step 2. Ensure the button is fully pushed in

3. While holding the button in, slowly let the chassis rise by removing the weight from the chassis. Once the tunnel stops moving up, the button should stay fully pushed in and the suspension will stay partially compressed. The holeshot device is now active.

NOTE: In this state, any sudden pressure on the footboard or movement of the sled will result in the holeshot device to deactivate.

4. Once the holeshot device is active, you can use the pipe warmer and get ready for the start. It is not recommend to jump on the footboard or bounce on the seat to settle the track once the holeshot device has been activated.

Adjustment Tips According to Vehicle Behavior

Problem	Corrective Measures
Front suspension darting	Check ski alignment. – Reduce front suspension spring preload. – Increase center spring preload. – Reduce rear spring preload.
Steering feels too heavy at steady speeds	– Reduce front suspension spring preload. – Increase center spring preload.
Steering feels too heavy during acceleration	– Reduce rear spring preload. – Lengthen limiter strap.
Too much ski lift during cornering or acceleration	– Shorten limiter strap. – Increase rear spring preload.
Rear of snowmobile seems too stiff	– Reduce rear spring preload. – Reduce compression damping adjustment if equipped.
Rear of snowmobile seems too soft	– Increase rear spring preload.
Rear suspension is frequently bottoming	– Increase compression damping adjustment if equipped. – Increase rear spring preload. – Increase center spring preload. – Lengthen limiter strap. – Increase compression damping adjustment if equipped.

Problem	Corrective Measures
Snowmobile seems to pivot around its center	<ul style="list-style-type: none">- Reduce center spring preload.- Increase rear spring preload.- Increase front suspension spring preload.- Shorten limiter strap.
Track spins too much at start	<ul style="list-style-type: none">- Lengthen limiter strap.

This page is intentionally blank

MAINTENANCE

MAINTENANCE SCHEDULE

Maintenance is very important for keeping your vehicle in safe operating condition.

This unit is produced for racing purpose only. Below are schedules for trail use but the snowcross use need maintenance and inspection after every training or race.

WARNING

Failure to properly maintain the vehicle according to the maintenance schedule and procedures can make it unsafe to operate.

Every Year at preseason or 3 000 km (2,000 mi) (Whichever Comes First)

Check fault codes

Adjust drive chain

Adjust and align track

Inspect brake hose, pads and disk

Check coolant density

Inspect drive belt

Visually inspect and clean drive pulley

Inspect and clean driven pulley

Lubricate rear suspension. Lubricate whenever the vehicle is used in wet conditions (rain, puddles)

Inspect exhaust system and check for leaks

Tighten exhaust manifold screws to specified torque

Inspect fuel lines, oil lines and connections

Inspect front suspension

Inspect rear suspension (including stopper straps and slider shoes)

Inspect tie-rod ends and ski alignment

**Every Year at preseason or 3 000 km (2,000 mi)
(Whichever Comes First)**

Adjust headlight beam aiming

Inspect engine rubber mounts

Lubricate front suspension shocks upper spherical bearings

**Every 2 Years or 6 000 km (4,000 mi) (Whichever Comes
First)**

Replace brake fluid

Inspect throttle cable

Clean and lubricate rewind starter

Replace chaincase oil

Inspect engine rubber mounts

**Every 3 Years Or 10 000 km (6,000 mi) (Whichever Comes
First)**

Replace spark plugs

Clean and inspect 3D RAVE valves. If oil is present in valve base,
replace seal

Every 5 Years

Replace engine coolant

Replace in-line fuel filter

MAINTENANCE PROCEDURES

This section includes instructions for basic maintenance procedures.

WARNING

Turn off the engine, remove tether cord cap and follow these maintenance procedures when performing maintenance. If you do not follow proper maintenance procedures you can be injured by hot parts, moving parts, electricity, chemicals or other hazards.

WARNING

Should removal of a locking device be required (e.g. lock tabs, self-locking fasteners, etc.) when undergoing disassembly/assembly, always replace with a new one.

Engine Coolant

WARNING

Never open coolant tank cap when engine is hot.

Engine Coolant Level Verification

Open the RH side panel, see *Body and Seat*.

Check coolant level at room temperature. Liquid should be at cold level line of coolant tank.

NOTE:

When checking level at low temperature it may be slightly lower than the mark.

If additional coolant is necessary or if entire system has to be refilled, refer to an authorized BRP snowmobile dealer, repair shop or person of your own choosing.

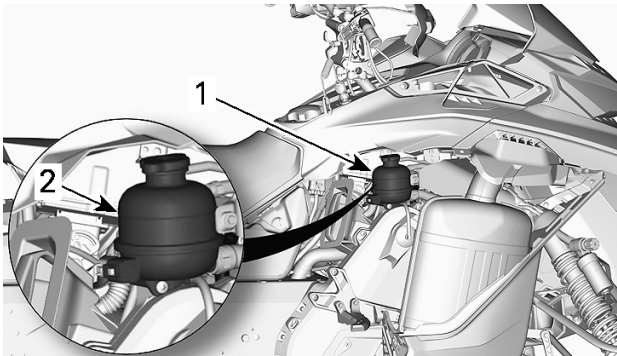
**TYPICAL**

1. Coolant reservoir
2. COLD line

Recommended Engine Coolant**RECOMMENDED COOLANT**

XPS Extended life pre-mixed coolant

IF THE RECOMMENDED XPS COOLANT IS NOT AVAILABLE

Distilled water and antifreeze solution (50% distilled water, 50% antifreeze)

NOTICE

Always use ethylene-glycol antifreeze containing corrosion inhibitors specifically for internal combustion aluminum engines.

Exhaust System**Exhaust System Verification**

The muffler tail pipe should be centered with the exit hole in the bottom pan. Exhaust system must be free of rust or leaks. Make sure that all parts are securely in place.

Check retaining springs and heat shields condition and replace if necessary.

The exhaust system is designed to reduce noise and to improve the total performance of the engine. Modification may be in violation of local laws.

NOTICE

If any exhaust system component is removed, modified or damaged, severe engine damage may result.

Spark Plugs

For spark plug type, refer to *Technical Specifications* subsection.

Replacing the Spark Plug

Use only an appropriate spark plug socket for removal and installation. Extra care should be taken to avoid side stresses which could result in a broken spark plug.

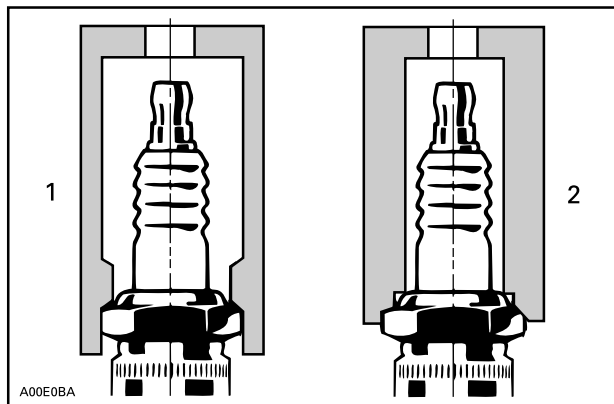

TYPICAL

1. Appropriate Spark plug socket
2. Inappropriate socket

Removing the Spark Plugs

1. Remove the upper body module. Refer to *Body* subsection.

2. Disconnect the stator connector. Refer to *Stator Connector Access* in the *Magneto and Starter* subsection.
3. Clean the spark plug and cylinder head with pressurized air.
4. Remove lock securing spark plug wire to spark plug.

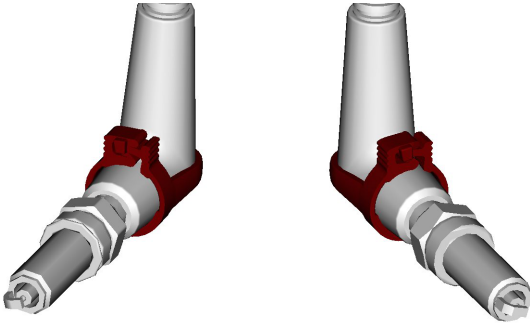

5. Remove spark plug cables by gently rotating the cap and pulling it off the plug.

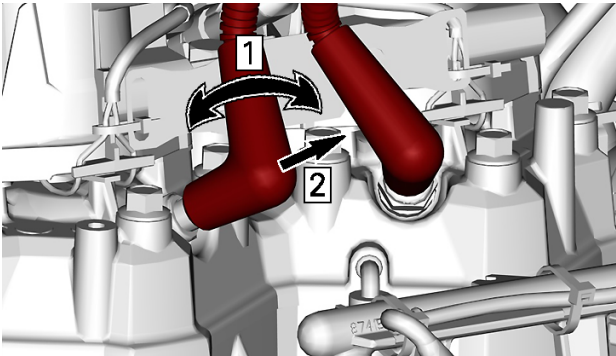

TYPICAL

- Step 1. Gently rotate
Step 2. Pull off

6. Unscrew the spark plug sufficiently to break the applied torque using the appropriate tools.



7. Remove spark plugs by hand.

Installing the Spark Plugs (OEM)

1. Prior to installation, ensure the contact surfaces of the cylinder head and spark plug are free of grime.
2. Lubricate contact surface of spark plug at the cylinder head.

Injection oil

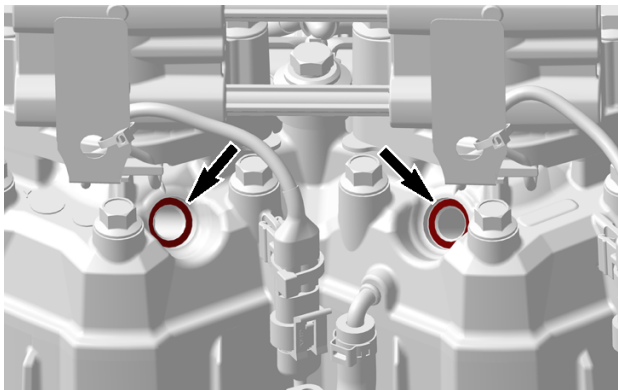

- Using a wire gauge, confirm electrode gap is as specified. Refer to *Technical Specifications*.

NOTE:

If spark plug gap is incorrect, use another spark plug.

- Hand screw spark plug into cylinder head until it bottoms out.
- Apply specific torque using a torque wrench and approved spark plug socket.

NOTE:

Spark plug tightening torque is particularly important on this engine as it contributes to the proper positioning of the negative electrode.

Tightening Torque	
Spark plug	23 ± 1 Nm

Installing the Spark Plugs (Non-OEM)

When using a non-OEM spark plug, it must be correctly indexed or engine may experience rough idling and higher emissions.

- Using a marker, mark the open end of the negative electrode on the plug shell (above threads).
- Prior to installation, ensure the contact surfaces of the cylinder head and spark plug are free of grime.
- Lubricate contact surface of spark plug at the cylinder head.

Injection oil

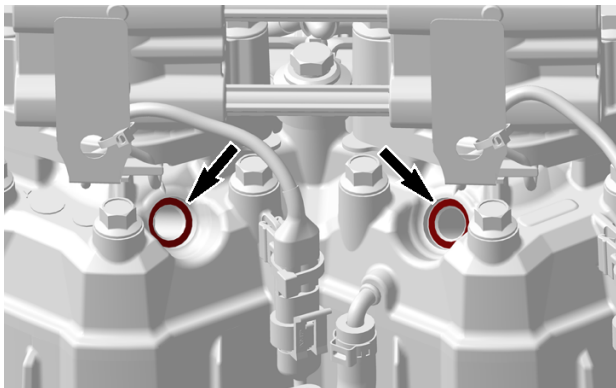

- Using a wire gauge, confirm electrode gap is as per manufacturer specification.

NOTE:

If spark plug gap is incorrect, use another spark plug.

- Hand screw spark plug into cylinder head until it bottoms out.
- Apply specific torque using a torque wrench and an appropriate spark plug socket.

Tightening Torque	
Spark plug	23 ± 1 Nm

- Visually check to ensure the open end of the negative electrode is facing the injector nozzle within 90° each side of nozzle.

The following illustration uses the point of attachment of the negative electrode to depict the angle. The injector is illustrated above the spark plug.

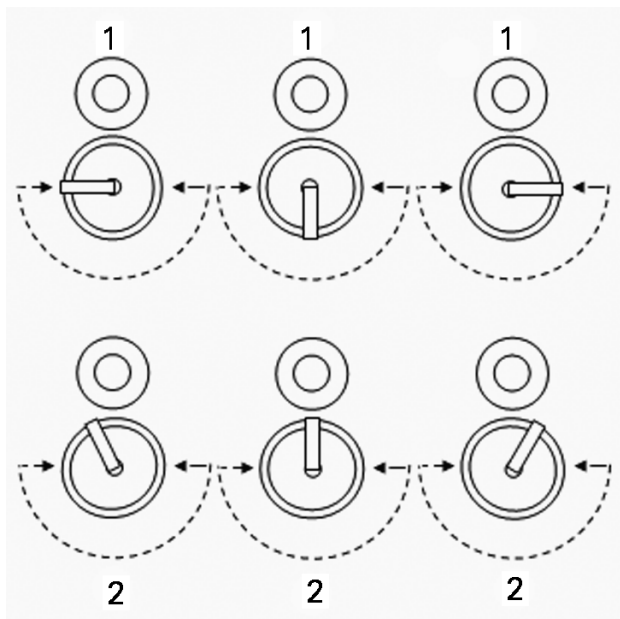

SPARK PLUG INDEXING

1. *Acceptable installation*
2. *Unacceptable installation*

If the plug indexing angle is not within specification, repeat procedure with another spark plug until correct indexing is achieved.

Brake Fluid

Recommended Brake Fluid

Recommended Brake Fluid
XPS DOT 4 Brake Fluid
Alternative or if not available
DOT 4 Brake Fluid

Use only DOT 4 brake fluid from a sealed container. An opened container may be contaminated or may have absorbed moisture from the air.

! WARNING

Use only DOT 4 brake fluid from a sealed container. To avoid serious damage to the braking system, do not use fluids other than the recommended one, nor mix different fluids for topping up.

Verifying the Brake Fluid Level - Model with Aluminum Reservoir

NOTICE

Vehicle must be on a level surface before checking any fluid levels.

1. Position the handlebar in the straight-ahead position to ensure the reservoir is level.
2. Check brake fluid in the reservoir for proper level.

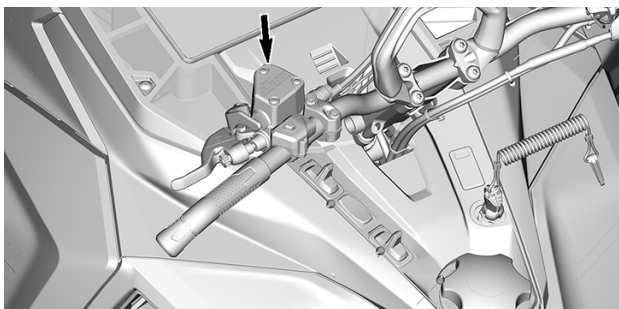

TYPICAL

Brake fluid must always be above the MIN. line when brake lever is squeezed.

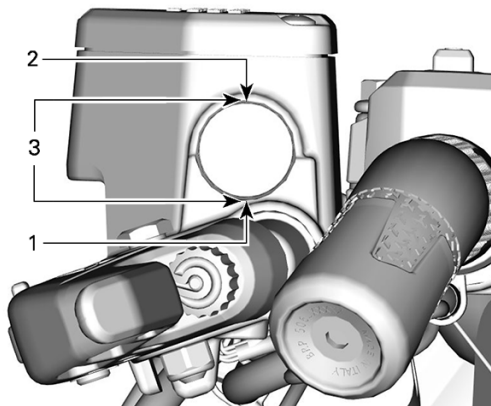
**TYPICAL**

1. Minimum
2. Maximum
3. Operating range

Adding Brake Fluid**NOTICE**

Vehicle must be on a level surface before checking any fluid levels.

1. Clean the reservoir cap area.

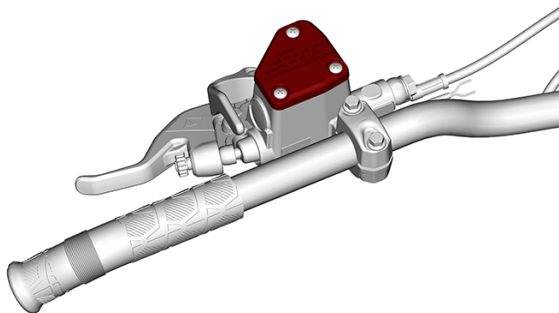

2. Remove the screws retaining the reservoir cap.

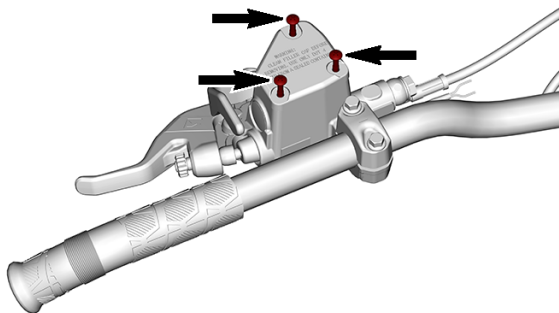

3. Remove the reservoir cap.

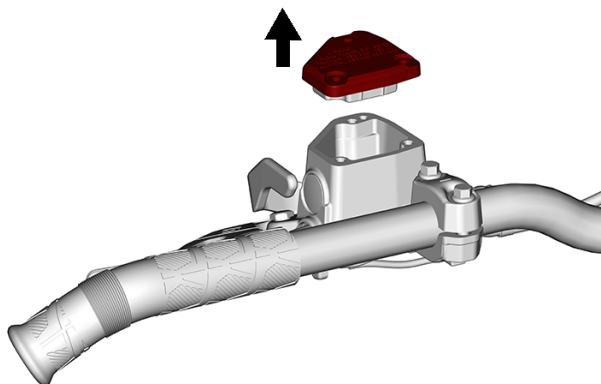

4. Add fluid as required. Do not overfill. Use only the recommended brake fluid.

! CAUTION

Avoid getting brake fluid on skin or eyes - it may cause severe burns. In case of contact with the skin, wash thoroughly. In case of contact with the eyes, immediately rinse with plenty of water for at least 10 minutes and then consult a doctor immediately.

NOTICE

- Brake fluid can damage paint, rubber and plastic parts
- Protect these nearby parts with a rag when servicing the brake system
- Rinse thoroughly in case of spillage.

5. Ensure the diaphragm is pushed in the reservoir cap before installing the cap on the reservoir.

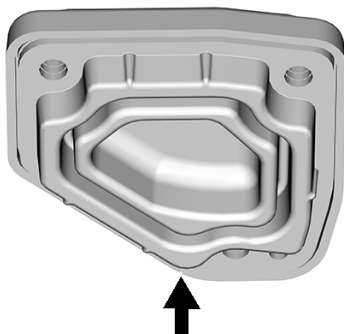

6. Reinstall reservoir cap and screws. Tighten to specification.

Tightening Torque	
Reservoir cap screws	0.7 ± 0.1 Nm (6 ± 1 lbf-in)

Chaincase Oil

Recommended Chaincase Oil

Recommended Chaincase Oil
XPS Synthetic chaincase oil
Alternative or if not available
75W140 gear oil that meets the API GL-5 specification

NOTICE

If the recommended XPS chaincase oil is not available, use a 75W140 gear oil that meets the API GL-5 specification. The chaincase of this snowmobile has been developed and validated using the XPS™ Synthetic chaincase oil. BRP strongly recommends the use of its XPS Synthetic chaincase oil at all times. Damages caused by oil which is not suitable for the chaincase will not be covered by the BRP limited warranty.

Verifying the Chaincase Oil Level

With the vehicle on a level surface, check the oil level by removing the check plug.

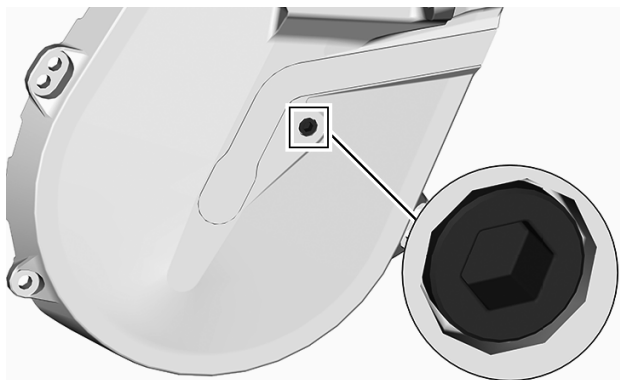
**CHECK PLUG**

Oil level must reach the threaded hole.

If level is correct, reinstall check plug and tighten to the specified torque.

Tightening Torque	
Check plug	6 ± 1 Nm (53 ± 9 lbf-in)

If level is insufficient, refer to *Chaincase Filling Procedure*.

Replacing the Chaincase Oil

Draining the Chaincase Oil

1. Place the vehicle on a level surface.
2. Place a drain pan under the chaincase drain plug area.
3. Remove filler cap.
4. Remove the drain plug located at the bottom of the chaincase.

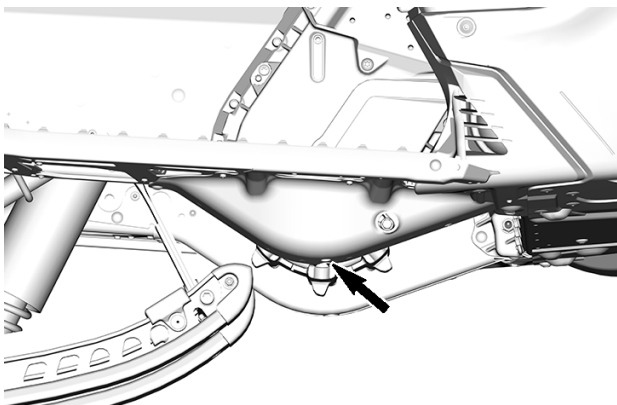

TYPICAL

5. Wait a while to allow all oil to drain out of the chaincase.
6. Install drain plug and tighten to specification.

Tightening Torque	
Chaincase drain plug	6 ± 1 Nm (53 ± 9 lbf-in)

Filling the Chaincase

1. Open the RH side panel. Refer to *Equipment*.
2. Remove the check plug.

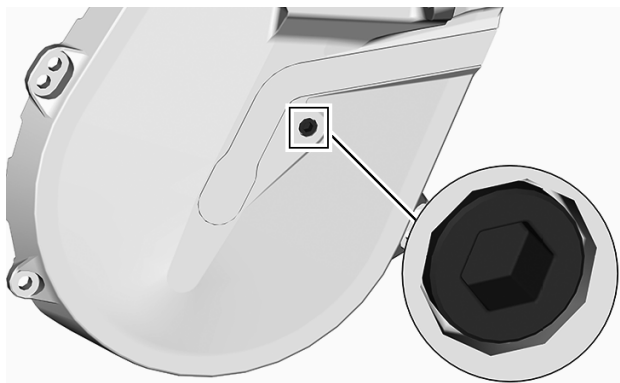

CHECK PLUG

3. Remove the filler cap.

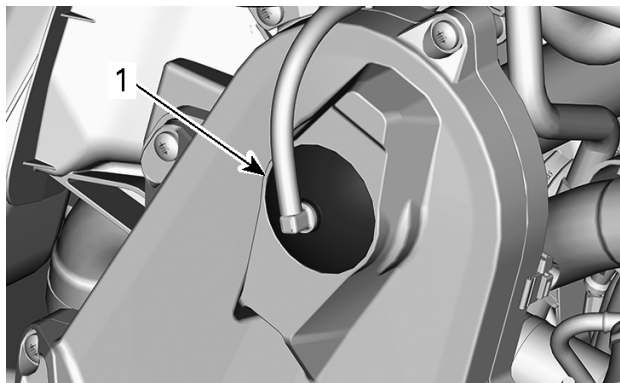

TYPICAL - TOP OF CHAINCASE

1. Filler cap

4. Pour recommended oil in the filler hole until oil comes out by the check plug hole.
5. Reinstall check plug and tighten to specification.

Tightening Torque	
Check plug	6 ± 1 Nm (53 ± 9 lbf-in)

Reinstall the filler cap.

Drive Chain

Access to Chaincase

Open RH side panel, refer to *Equipment*.

Drive Chain Adjustment

Using the Torx end of the driven pulley expander, GENTLY turn tensioner clockwise to eliminate the play.

NOTE: Make sure the play is completely eliminated by trying to turn back and forth the driven pulley.

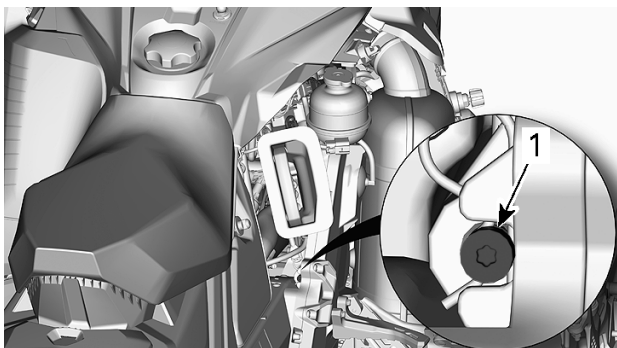

TYPICAL

Do not force the tensioner in.

NOTE:

Do not remove the hair cotter pin.

NOTICE

Overtightening the drive chain could result in severe damage to the chaincase components.

Drive Belt

Drive Belt Inspection

Remove the drive belt guard. Refer to the procedure in *Equipment*.

Inspect belt for cracks, fraying or abnormal wear (uneven wear, wear on one side, missing cogs, cracked fabric). If abnormal wear is noted, probable cause could be pulley misalignment, excessive RPM with frozen track, fast starts without warm-up period, burred or rusty sheave, oil on belt or distorted spare belt. Contact an authorized BRP snowmobile dealer.

Replacing the Drive Belt

Drive Belt Removal

1. Remove tether cord cap from engine cut-off switch.
2. Remove drive belt guard. Refer to *Equipment*.
3. Insert the driven pulley expander provided in the threaded hole on the adjuster hub as shown.



4. Open the driven pulley by screwing the tool in.
5. Remove the drive belt by slipping it over the top of the driven pulley, then over the drive pulley.

Installing the Drive Belt

The driven pulley must be expanded. Refer to *Removing the Drive Belt*.

1. Slip the belt over the drive pulley, then over the driven pulley.

NOTICE

Do not force or use tools to pry the belt into place, as this could cut or break the cords in the belt.

NOTE:

The maximum drive belt life span is obtained when belt is installed with arrows in the direction of rotation.

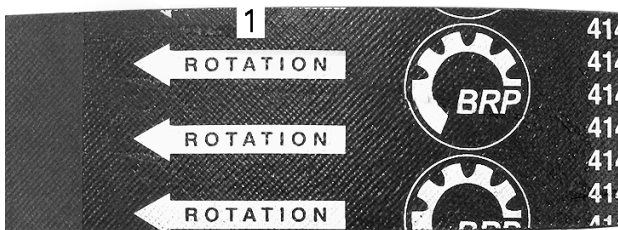

1. To be pointed in the direction of rotation
2. Unscrew and remove the driven pulley expander from the pulley.
3. Rotate the driven pulley several times to properly set the belt between the sheaves.
4. If a new belt was installed, an adjustment will be required for the proper belt height. Refer to *Adjusting the Drive Belt Height*.
5. Install belt guard.
6. Close side panel.

Drive Belt Adjustment

Drive belt adjustment must be performed every time a new belt is installed and as part of the pre-ride inspection.

To adjust the drive belt, proceed as follows:

1. Remove the tether cord cap.
2. Open the LH side panel. Refer to *Body and Seat*.
3. Remove the belt guard. Refer to *Equipment*.
4. Keep the set screw from turning using a 1/8 inch Allen wrench and loosen the lock nut using a 7/16 in open wrench.
5. Turn the set screw 1/4 turn at a time then rotate the driven pulley to properly set the belt between the pulley sheaves. Measure belt deflection using a straight edge and a tensiometer as explained below.

Required tool	
Tensiometer 414 348 200	



- Repeat until the right belt deflection is reached.

NOTE:

Turn the set screw clockwise to increase the distance between the sheaves and counterclockwise to decrease the distance.

- Tighten the lock nut after the belt adjustment has been made.

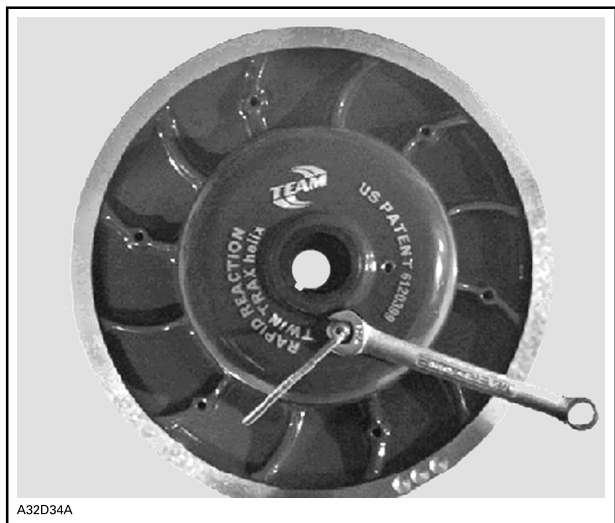
**Belt Deflection Measurement**

- Set deflection between 27 mm (1.06 in) and 37 mm (1.46 in) using bottom O-ring.



DEFLECTION SETTING

1. Bottom O-ring set to specification
2. Place upper O-ring to 0 kgf (0 lbf).
3. Position a straight edge ruler on the drive belt.
4. Position the tensiometer on drive belt, halfway between pulleys.
5. Push the tensiometer downwards until bottom O-ring (deflection) be aligned with the inner edge of the straight ruler.
6. Read load recorded by the upper O-ring on the tensiometer.

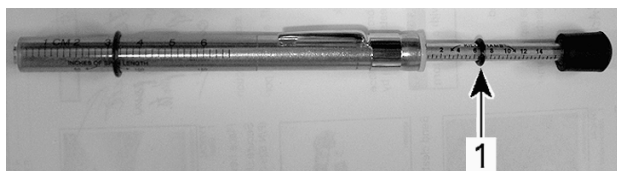

LOAD READING

1. Upper O-ring
7. Load reading must be as per the following table.

Drive belt Adjustment specification	
Belt deflection setting	27 to 37 mm (1.06 to 1.46 in)
Belt load reading	11.3 kg (25 lb)

8. Adjust as required.

Drive Pulley

Drive Pulley Adjustment (if equipped)

 **WARNING**

Remove tether cord cap from engine cut-off switch before performing any adjustment. Vehicle must be parked in a safe place, away from the trail.

 **WARNING**

NEVER disassemble or modify the drive pulley. Improper assembly or modifications could cause the pulley to explode violently under the stress generated by the high rotational speed. Visit your BRP snowmobile dealer to maintain or service the drive pulley. Improper servicing or maintenance may affect performance and reduce belt life. Always respect maintenance schedules.

The drive pulley is factory calibrated to transmit maximum engine power at a predefined RPM. Factors such as ambient temperature, altitude or surface condition may vary this critical engine RPM thus affecting snowmobile efficiency.

This adjustable drive pulley allows setting maximum engine RPM to maintain maximum power.

Ramp cams should be adjusted so that actual maximum engine RPM matches the maximum horsepower RPM. Refer to *Technical Specifications (Engine)*.

NOTE:

Use a precision digital tachometer for engine RPM adjustment.

There are 5 positions in which the ramp cam can be set.

Each position modifies the maximum engine RPM by about 200 RPM.

Lower position numbers decrease engine RPM in steps of 200 RPM and higher position numbers increase it in steps of 200 RPM.

Procedure

1. Refer to *Body and Seat in Vehicle Information* and remove:
 - LH side panel
 - Drive pulley guard

2. Locate the cam and the pivot screw on the drive pulley.

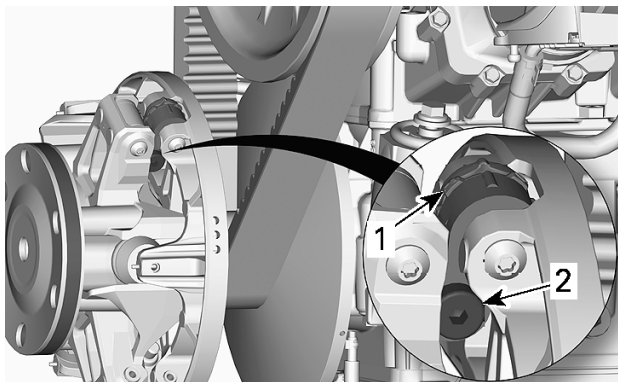

TYPICAL

1. Cam
2. Pivot screw

The cam position is identified as follows:

- Positions 1, 2, 4 and 5 are numbered.
- Position 3 (middle) is identified by a notch.
- There are notches on each side of the cam used as pointers.

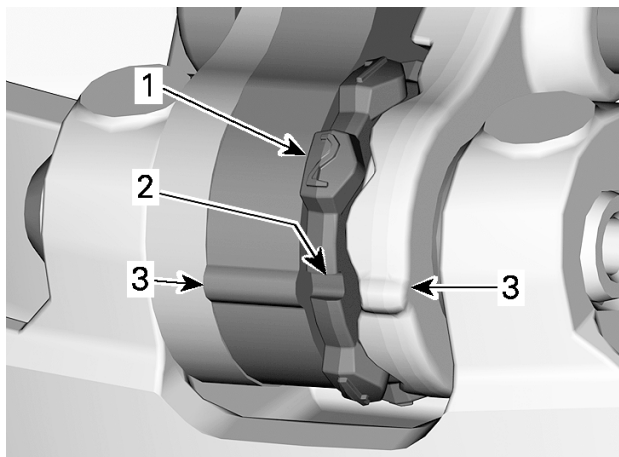

1. *Numbered position*
2. *Position 3 - Notch*
3. *Pointers*

To adjust, proceed as follows for all 3 cams:

3. Using the Allen end of the driven pulley expander, loosen the pivot screw.

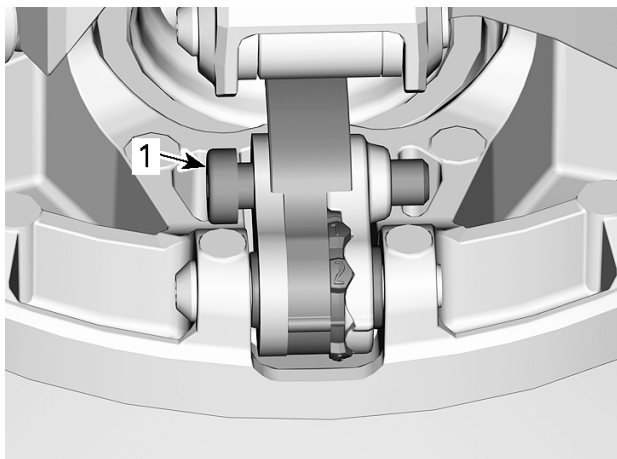

1. *Pivot screw*

4. Move the right lever aside to be able to turn the cam.
5. Turn cam to the desired position.

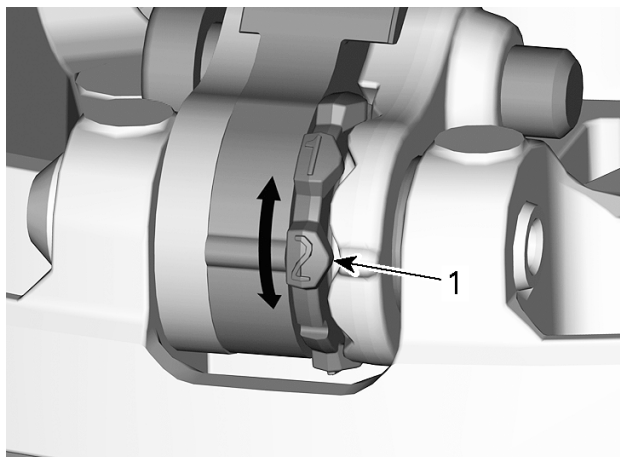

1. Desired cam position (here #2)

6. Tighten the pivot screw.

TIGHTENING TORQUE	
Pivot	$8 \pm 1 \text{ Nm}$ ($71 \pm 9 \text{ lbf-in}$)

NOTICE

Always adjust all 3 cams to the same setting.

Track

Track Condition

WARNING

Remove tether cord cap from engine cut-off switch before performing any maintenance or adjustment, unless otherwise specified. Vehicle must be parked in a safe place, away from the trail.

Remove tether cord cap from engine cut-off switch.

Lift the rear of the snowmobile and support it with a wide-base snowmobile mechanical stand with a rear deflector panel. With the engine off, rotate the track by hand, and inspect condition. If worn or cut, or if track fibers are exposed, or if missing or defective inserts or guides are noted; contact an authorized BRP snowmobile dealer.

Snowmobiles Equipped with Traction Enhancing Products

If your snowmobile is equipped with a BRP approved studded track, **PROCEED WITH A VISUAL INSPECTION OF YOUR TRACK BEFORE EACH USE.**

Look for any defects, such as:

- Perforations in the track
- Tears in the track (particularly around traction holes on studded tracks)
- Lugs that are broken or torn off, exposing portions of rods
- Delamination of the rubber
- Broken rods
- Broken studs (studded tracks)
- Bent studs (studded tracks)
- Missing studs
- Studs that are torn off the track
- Missing track guide(s)
- Also, ensure that studs nut are tighten to the recommended torque.

On approved studded tracks, replace broken or damaged studs immediately. If your track shows signs of deterioration, it must be replaced immediately. When in doubt, ask your dealer.

 **WARNING**

Riding with a damaged track or studs could lead to a loss of control.

For complete information on traction enhancing products, refer to *TRACTION ENHANCING PRODUCTS* in *SAFETY INFORMATION* at the beginning of this Operator's Guide.

Track Tension and Alignment

NOTE:

Track tension and alignment are interrelated. Do not adjust one without the other.

⚠ WARNING

To prevent serious injury to individuals near the snowmobile:

- NEVER stand behind or near a moving track.
- Always use a wide-base snowmobile stand with a rear deflector panel if it is necessary to rotate track.
- When the track is raised off the ground, only run it at the lowest possible speed.

Centrifugal force could cause debris, damaged or loose studs, pieces of torn track, or an entire severed track to be violently thrown backwards out of the tunnel with tremendous force, possibly resulting in the loss of a leg or other serious injury.

Verifying the Track Tension

NOTE:

Ride the snowmobile in snow about 15 to 20 minutes prior to adjusting track tension.

1. Remove tether cord cap from engine cut-off switch.
2. Lift rear of vehicle and support it off the ground.

⚠ CAUTION

Use proper lifting techniques, notably using your legs force. Do not attempt to lift the rear of vehicle if it is above your limits.

3. Allow rear suspension to fully extend.
4. Prepare the tensiometer.

Service tool	
Tensiometer (P/N 414348200)	

1. Set the bottom O-ring as per the *Track Deflection* from the applicable vehicle in the *Technical Specifications* table.



1. Bottom O-ring

2. Place the upper O-ring to 0 kgf (0 lbf).

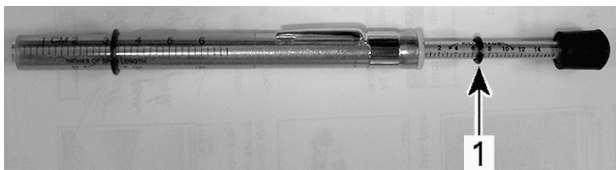

1. Upper O-ring

5. Position the tensiometer on track, halfway between front and rear idler wheels.
6. Push the tensiometer downwards until bottom O-ring (deflection set earlier) be aligned with the bottom of slider shoe.

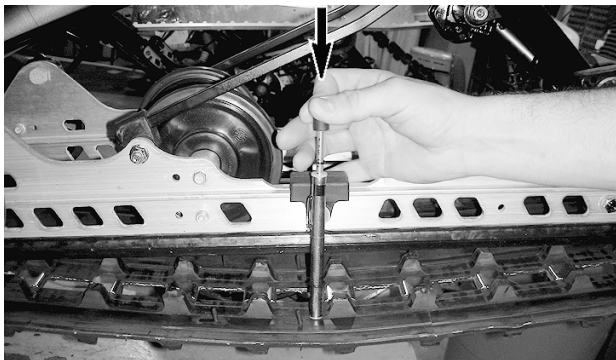

TYPICAL

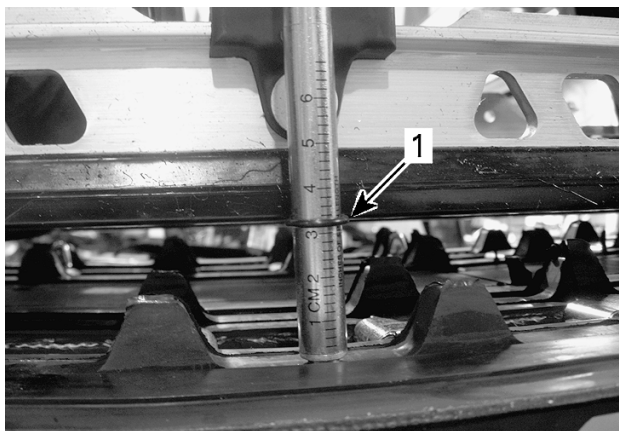

TYPICAL

1. Deflection O-ring aligned with slider shoe

7. Read load recorded by the upper O-ring on the tensiometer.



TYPICAL - LOAD READING

1. Upper O-ring

8. Load reading must be as per the track deflection in the *Technical Specifications*.
9. If load reading is not in accordance with the specification, adjust track tension. Refer to *Track Tension Adjustment*.

Adjusting the Track Tension

1. Remove the tether cord cap from engine cut-off switch.
2. Lift and support the rear of vehicle.

⚠ CAUTION

Use proper lifting techniques, notably using your legs force. Do not attempt to lift the rear of vehicle if it is above your limits.

3. Loosen the RH side rear idler wheel retaining nut half a turn while holding the LH side nut.

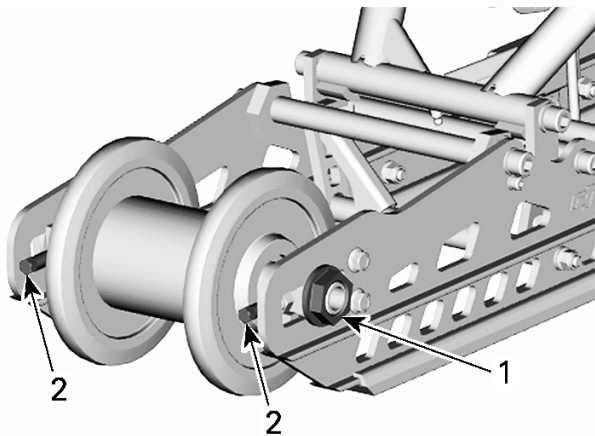

TRACK REMOVED FOR CLARITY

1. *RH rear idler wheel nut*
2. *Adjustment screws*

4. Through the track holes, tighten or loosen both adjustment screws to increase or decrease track tension.

NOTE:

You may need to position the track to access the adjustment screws.

5. If correct tension is unattainable, contact an authorized Ski-Doo dealer.
6. Retighten the retaining nut to specifications while holding axle.

Tightening Torque	
Rear axle nut	48 ± 6 Nm (35 ± 4 lbf-ft)

7. Check track alignment as described below.

Aligning the Track

WARNING

Before checking track alignment, ensure that the track is free of all particles which could be thrown out while track is rotating. Keep hands, tools, feet and clothing clear of track. Always lift the snowmobile on a wide-base stand with a rear deflector panel. Ensure no one is standing in close proximity to the snowmobile, especially at the rear of the track. Never rotate track at high speed.

Centrifugal force could cause debris, damaged or loose studs, pieces of torn track, or an entire severed track to be violently thrown backwards out of the tunnel with tremendous force.

1. Lift rear of vehicle and support it off the ground.

CAUTION

Use proper lifting techniques, notably by using the force of your legs. Do not attempt to lift the rear of vehicle if it is above your limits.

2. Start engine and accelerate slightly so that track slowly turns. This must be done in a short period of time (15 to 20 seconds).
3. Check that the track is well centered; equal distance on both sides between edges of track guides and slider shoes.

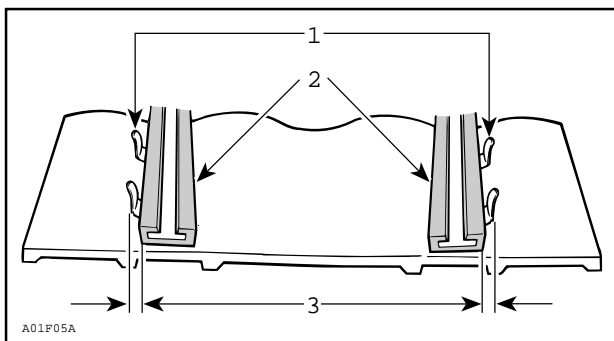

1. Guides
2. Slider shoes
3. Equal distance

4. To correct track alignment:

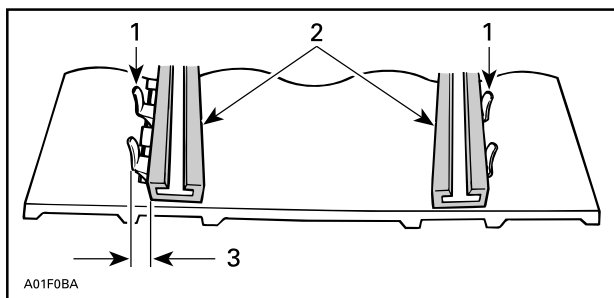

1. Guides
2. Slider shoes
3. Tighten on this side

1. Stop engine.
2. Remove tether cord cap from engine cut-off switch.

⚠ WARNING

Remove tether cord cap from engine cut-off switch before performing any maintenance or adjustment, unless otherwise specified. Vehicle must be parked in a safe place, away from the trail.

3. Loosen the rear axle nut.
4. Tighten adjustment screw on side where the slider shoe is the farthest from the track insert guides.
5. Tighten the rear axle nut.

⚠ WARNING

Properly tighten wheel retaining bolt, otherwise wheel may come off and cause track to "lock".

6. Restart engine and rotate track slowly to recheck alignment.
7. Tighten the rear axle nut to specified torque.

Tightening Torque	
Rear axle screw	48 ± 6 Nm (35 ± 4 lbf-ft)

8. Reposition snowmobile on the ground.

Suspension

Rear Suspension Condition

Visually inspect all suspension components including slider shoes, springs, wheels, etc.

NOTE:

During normal driving, snow will act as a lubricant and coolant for the slider shoes. Extensive riding on ice or sanded snow, will create excessive heat build-up and cause premature slider shoe wear.

Suspension Stopper Strap Condition

Inspect stopper straps for wear and cracks, bolt and nut for tightness. If loose inspect holes for deformation. Replace as required. Tighten nut to specification.

Tightening Torque	
Stopper strap nut	7 ± 1 Nm (62 ± 9 lbf-in)

Suspension Lubrication

Lubricate the following suspension pivots at grease fittings. Refer to *Maintenance Schedule* for maintenance frequency.

Suspension grease
Synthetic suspension grease

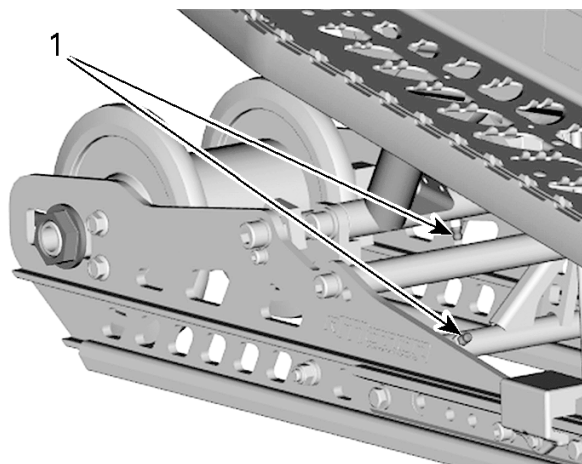

1. Grease fittings

Steering and Front Suspension Condition

Visually inspect steering and front suspension for tightness of components (steering arms, control arms and links, tie rods, ball joints, ski bolts, ski legs, etc.). If necessary, contact an authorized BRP snowmobile dealer.

Skis

Wear and Condition of Skis and Runners

Check the condition of the skis and ski runner carbides. If worn, contact an authorized BRP snowmobile dealer.

! WARNING

Excessively worn skis and/or ski runners will adversely affect snowmobile control.

Fuses

Access to Fuse Block

Open RH side panel, refer to *Body and Seat*.

Fuses Location

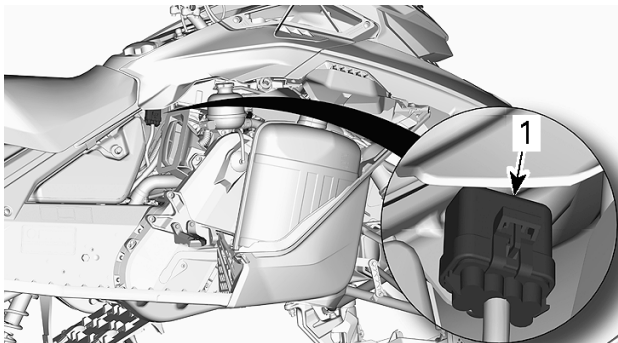

TYPICAL

1. Fuse block

Unlock fuse block from its cover.

Refer to *Technical Specifications* for fuse rate and configuration.

Fuse Inspection

Check fuse condition and replace it if necessary.

To remove fuse from holder, pull fuse out. Check if filament is melted.

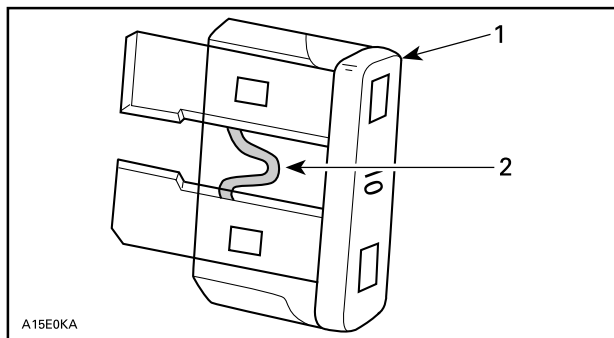

1. Fuse
2. Check if melted

⚠ WARNING

Do not use a higher rated fuse.

⚠ WARNING

If fuse has burnt out, source of malfunction should be determined and corrected before restarting. See an authorized BRP snowmobile dealer for servicing.

Headlights

Headlights Replacement

The headlights bulbs are not replaceable. Replace as an assembly.

Remove the upper body module. Refer to *Body and Seat*.

Remove the screws holding the light assembly.

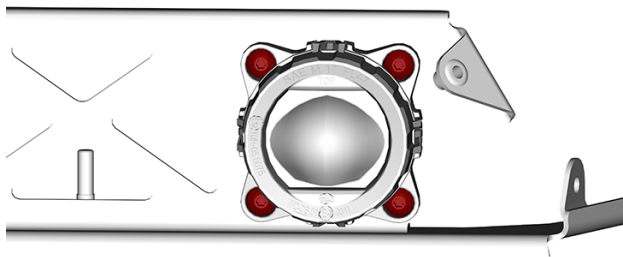

Disconnect the and remove the light assembly.

Install the new assembly and tighten the mounting screws to specification.

Tightening Torque	
Headlight screw	2.5 ± 0.5 Nm (22 ± 4 lbf-in)

Headlights Beam Aiming

Remove RH side panel. Refer to *Body and Seat*.

Turn the adjustment screw to reach desired beam height and direction.

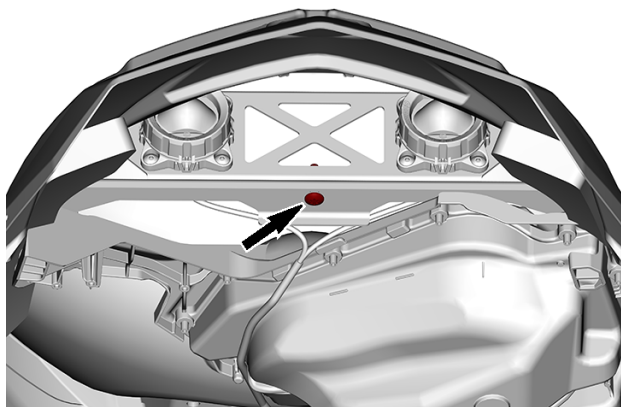

VEHICLE CARE

Post-Operation Care

Remove snow and ice from rear suspension, track, front suspension, steering mechanism and skis.

 **WARNING**

Make sure D.E.S.S. key is removed from D.E.S.S. post before standing in front the vehicle, getting close to the track or rear suspension components.

Always cover your snowmobile when leaving it outside overnight or during extended periods of inactivity. This will protect it from frost and snow as well as help retain its appearance.

Vehicle Cleaning and Protection

Wash snowmobile using water mixed with a mild detergent.

Use only microfiber cloths or an equivalent.

NOTICE

Never use a high pressure washer to clean the vehicle. Use low pressure only, like a garden hose.

Non Compatible Cleaning Products

Material Type	Non-Compatible Cleaning Products
All plastics, vinyls, painted steel and aluminium	BRAKE AND PARTS CLEANER OR ANY PETROLEUM BASE CLEANING PRODUCTS

Compatible Cleaning Products

Material Type	Cleaning Product
All plastics, vinyls, painted steel and aluminium.	Automotive type soap with water XPS Spray Cleaner and Polish XPS All Purpose Cleaner

For more information and products, Visit the XPS Products website at www.xpslubricants.com

STORAGE

During summer, or when a snowmobile is not in use for more than three months, proper storage is necessary.

Storage
Clean the vehicle
Add fuel stabilizer to fuel following the product manufacturer recommendations. Run the engine after adding the product to the fuel. Run the engine until there is no fuel left.
Lubricate the engine.
Lubricate brake lever pivot
Lubricate rear suspension
Block muffler outlet with rags
Lift rear of vehicle until track is clear of the ground. Do not release track tension

CAUTION

Use appropriate lifting device or have assistance to share lifting stress. If a lifting device is not used, use proper lifting techniques, notably using your legs force. Do not attempt to lift the rear of vehicle if it is above your limits.

NOTICE

The snowmobile has to be stored in a cool and dry place and covered with an opaque but ventilated tarpaulin. This will prevent sun rays and grime from affecting plastic components and vehicle finish.

NOTICE

Fuel stabilizer should be added prior to engine lubrication to prevent the loss of the chemical properties of fuel and protect the fuel system against varnish deposits.

MAINTENANCE RECORDS

Send photocopy of maintenance record to BRP if needed.

Pre-delivery	
Serial number: _____	Signature/Print:
Mileage / km: _____	
Hours: _____	
Date: _____	
Dealer no: _____	
Notes: _____	

Refer to vehicle Pre-Delivery Bulletin for detailed installation procedures	

First inspection	
Mileage / km: _____	Signature/Print:
Hours: _____	
Date: _____	
Dealer no: _____	
Notes: _____ _____	
For maintenance schedule refer to Maintenance Information section of this operator's guide	

Service	
Mileage / km: _____	Signature/Print:
Hours: _____	
Date: _____	
Dealer no: _____	
Notes: _____ _____	
For maintenance schedule refer to Maintenance Information section of this operator's guide	

Service	
Mileage / km: _____ Hours: _____ Date: _____ Dealer no: _____ Notes: _____ _____ _____	Signature/Print:
For maintenance schedule refer to Maintenance Information section of this operator's guide	

Service	
Mileage / km: _____ Hours: _____ Date: _____ Dealer no: _____ Notes: _____ _____ _____	Signature/Print:
For maintenance schedule refer to Maintenance Information section of this operator's guide	

Service	
Mileage / km:	Signature/Print:
Hours:	
Date:	
Dealer no:	
Notes:	
For maintenance schedule refer to Maintenance Information section of this operator's guide	

Service	
Mileage / km:	Signature/Print:
Hours:	
Date:	
Dealer no:	
Notes:	
For maintenance schedule refer to Maintenance Information section of this operator's guide	

Service	
Mileage / km: _____ Hours: _____ Date: _____ Dealer no: _____ Notes: _____ _____ _____	Signature/Print:
For maintenance schedule refer to Maintenance Information section of this operator's guide	

Service	
Mileage / km: _____ Hours: _____ Date: _____ Dealer no: _____ Notes: _____ _____ _____	Signature/Print:
For maintenance schedule refer to Maintenance Information section of this operator's guide	

Service	
Mileage / km:	Signature/Print:
Hours:	
Date:	
Dealer no:	
Notes:	
For maintenance schedule refer to Maintenance Information section of this operator's guide	

Service	
Mileage / km:	Signature/Print:
Hours:	
Date:	
Dealer no:	
Notes:	
For maintenance schedule refer to Maintenance Information section of this operator's guide	

Service	
Mileage / km: _____ Hours: _____ Date: _____ Dealer no: _____ Notes: _____ _____ _____	Signature/Print:
For maintenance schedule refer to Maintenance Information section of this operator's guide	

Service	
Mileage / km: _____ Hours: _____ Date: _____ Dealer no: _____ Notes: _____ _____ _____	Signature/Print:
For maintenance schedule refer to Maintenance Information section of this operator's guide	

Service	
Mileage / km: _____	Signature/Print:
Hours: _____	
Date: _____	
Dealer no: _____	
Notes: _____	

For maintenance schedule refer to Maintenance Information section of this operator's guide	

Service	
Mileage / km: _____	Signature/Print:
Hours: _____	
Date: _____	
Dealer no: _____	
Notes: _____	

For maintenance schedule refer to Maintenance Information section of this operator's guide	

TECHNICAL INFORMATION

VEHICLE IDENTIFICATION

Vehicle Description Decal

Vehicle description decal is located on right hand side of tunnel.

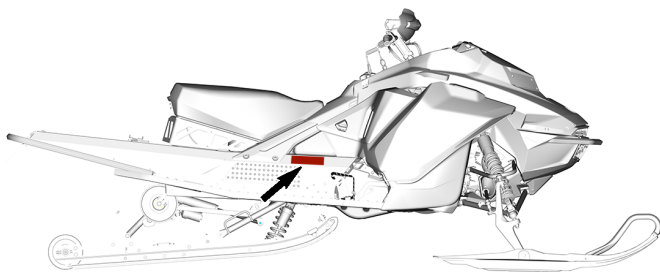

BOMBARDIER RECREATIONAL PRODUCTS Inc. Date <input type="text"/>	
VIN. / NIV.	<input type="text"/>
Description	Type: SNO/MNG
<input type="text"/>	
ASSEMBLED IN CANADA / ASSEMBLÉ AU CANADA	

51609002

VEHICLE ASSEMBLED IN CANADA

Identification Numbers

The main components of your snowmobile (engine and frame) are identified by different identification numbers. It may sometimes become necessary to locate these numbers for warranty purposes or to trace your snowmobile in the event of loss. These numbers are required by the authorized BRP snowmobile dealer to complete warranty claims properly. We strongly recommend that you take note of all the identification numbers on your snowmobile and supply them to your insurance company.

Vehicle Identification Number (VIN)

VIN is scribed on vehicle description decal. See above. It is also engraved on tunnel near vehicle description decal.

Model number and model year are part of the information found in the VIN. See illustration.

2BP	S	LSAB	9	A	V	000001
2BP = Canada YH2 = Finland	S = Ski-Doo L = Lynx	Model number	Numeric or Alphabetic		Factory V = Valcourt R = Rovaniemi	Serial number
						Model year: P = 2023 R = 2024

Engine Identification Number Location

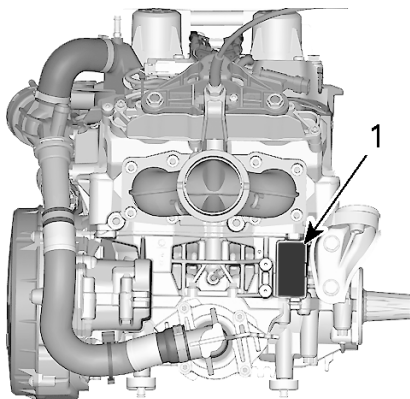

1. Engine identification number

COMPLIANCE LABELS

EPA Exemption Label



EMISSION CONTROL INFORMATION

THIS SNOWMOBILE IS DESIGNED EXCLUSIVELY FOR COMPETITION
AND IS EXEMPT FROM EMISSION STANDARDS AND RELATED
REQUIREMENTS UNDER 40 CFR 1051.620 AND SOR/2011-10 5.(4).

RENSEIGNEMENTS SUR LE DISPOSITIF ANTIPOLLUTION

CETTE MOTONEIGE EST CONÇUE EXCLUSIVEMENT POUR
LA COMPÉTITION ET EST EXCLUE DES NORMES D'ÉMISSIONS
ET DE LEURS REQUIS SELON 40 CFR 1051.620 ET DORS/2011-10 5.(4).

11423

EPA EXEMPTION LABEL

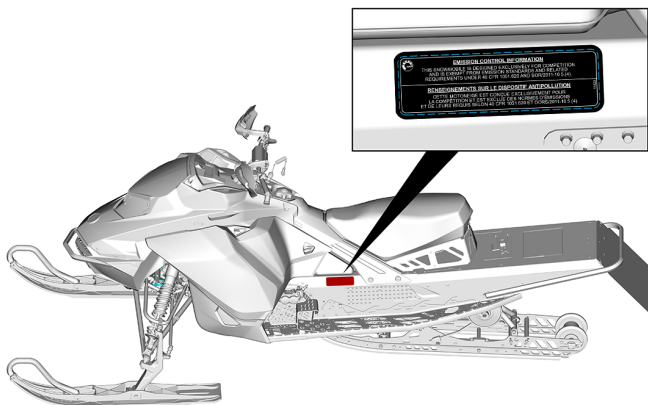

SSCC Label

Safety standards for snowmobiles have been adopted by the Snowmobile Safety and Certification Committee (SSCC) of which BRP is a proud participating member. Assurance that your snowmobile meets these standards is easily checked by locating the Certification Label on a right vertical portion of the vehicle.

The following label shows that an independent testing laboratory has verified compliance with the SSCC safety standards.

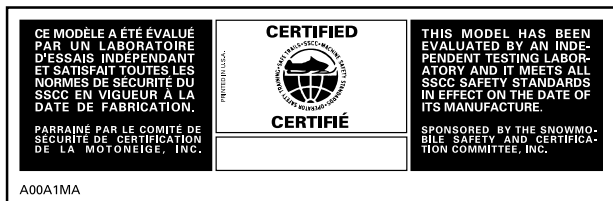

SSCC LABEL

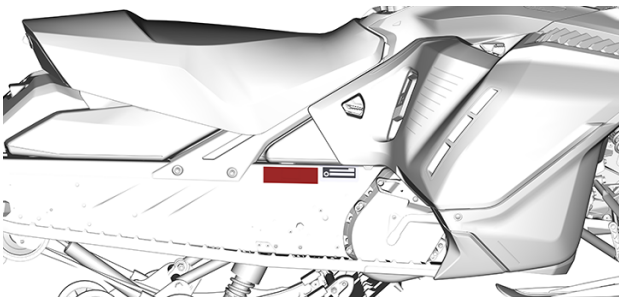

TYPICAL

Regulation (EU) 2016/1628 applicable for Non-Road Mobile Machineries

Depending on your particular vehicle configuration, an additional NRMM identification label may be installed on the tunnel, near the chaincase.

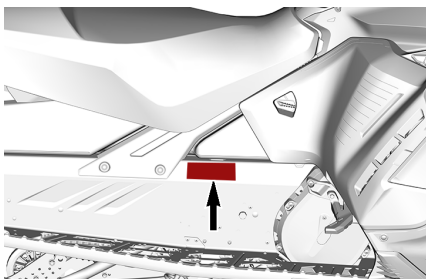

TYPICAL - ON RH SIDE OF TUNNEL

	Bombardier Recreational Products Inc.	
	565 de la Montagne, Valcourt, QC, Canada J0E 2L0	
	BRP-Rotax GmbH Co. KG, Rotaxstrasse 1, Gunskirchen, A-4623 Austria	12024

NRMM IDENTIFICATION ON VEHICLE

EU DECLARATION OF CONFORMITY



565 de la Montagne Street
Valcourt (Quebec) J0E 2L0
Canada
www.brp.com

EU Declaration of Conformity

Authorized Representative: BRP-Rotax GmbH Co. KG, Rotaxstrasse 1, Guns kirchen, A-4623, Austria

This declaration of conformity is issued under the sole responsibility of the manufacturer.

The undersigned, representing the manufacturer, hereby declares that model year **2025 Snowmobiles** marked with the **CE** mark and a 17-character vehicle identification number (VIN) structured as **2BPSxxxxxSVxxxxxx** or **YH2SxxxxxSRxxxxxx** under commercial name **Ski-Doo** comply with all the relevant provisions of the following Directives and Regulations:

Machinery Directive 2006/42/EC as amended up to and including Reg. 2019/1243/EU	ISO 12100:2010
Non-Road Mobile Machinery (NRMM) Regulation (EU) 2016/1628 on gaseous pollutants	Category SMB, Stage V emissions limits
Electromagnetic Compatibility (EMC) Directive 2014/30/EU as amended up to and including Reg. (EU) 2018/1139	CISPR 12:2007/A1:2009 & IEC 61000-6-1:2005 or UN R10.04 or later version
Battery Directive 2006/66/EC as amended up to and including Dir. (EU) 2018/849	EN 50342-7:2015
Radio Equipment (RED) Directive 2014/53/EU as amended up to and including Reg. 2018/1139 (If fitted with radio frequency (RF) D.E.S.S. key)	IEC 62368-1:2014 CISPR 25:2016 ISO 11452-2:2004 ETSI EN 300 330 V2.1.1:2017

Dominic Tessier

Dominic Tessier (Nov 27, 2023 20:30 EST)

Dominic Tessier, Eng.
Director, Vehicle Engineering, Ski-Doo
Bombardier Recreational Products Inc.

Valcourt, QC, Canada
Nov 27, 2023

SKI-DOO LYNX SEAWOOD EVIRIDE ROTAX CAN-AM

UK DECLARATION OF CONFORMITY



565 de la Montagne Street
Valcourt (Québec) J0E 2L0
Canada
www.brp.com

UK Declaration of Conformity

Authorized Representative: BRP UK Ltd., (BWM Accountants Limited), Suite 5.1, 12
Tithebarn Street, Liverpool, L2 2DT

This declaration of conformity is issued under the sole responsibility of the manufacturer.

The undersigned, representing the manufacturer, hereby declares that model year **2025** **Snowmobile** marked with the ^{UK} mark and a 17-character vehicle identification number (VIN) structured as **2BPSxxxxxSVxxxxxx** or **YH2SxxxxxSRxxxxxx** under commercial name **Ski-Doo** comply with all the relevant provisions of the following UK Statutory instrument and Regulations:

The Supply of Machinery (Safety) Regulations 2008, UK Statutory Instrument 2008/1597 as amended up to and including SI 2020/1112	ISO 12100:2010
Non-Road Mobile Machinery (Type-Approval and Emission of Gaseous and Particulate Pollutants) Regulation 2018, UK SI 2018/764 as amended up to and including SI 2020/1393	Category SMB, Stage V emissions limits
Electromagnetic Compatibility Regulations 2016, UK SI 2016/1091 as amended up to and including SI 2020/1112	CISPR 12:2007/A1:2009 & IEC 61000-6-1:2005 or UN R10.04 or later version
Batteries and Accumulators (Placing on the Market) Regulations 2008, UK SI 2008/2164 as amended up to and including UK SI 2020/904	EN 50342-7:2015
Radio Equipment Regulations 2017, UK SI 2017/1206 as amended up to and including SI 2020/1112	IEC 62368-1:2014 CISPR 25:2016 ISO 11452-2:2004 ETSI EN 300 330 V2.1.1:2017

Dominic Tessier

Dominic Tessier (Nov 27, 2023 20:31 EST)

Dominic Tessier, Eng.
Director, Vehicle Engineering, Ski-Doo
Bombardier Recreational Products Inc.

Valcourt, QC, Canada
Nov 27, 2023

ski-doo LYNX SEADOO EVINRUDE ROTAX CAN-AM

**Left blank for Eurasian Conformity
mark where applicable**

BRP RF DESS POST GEN2 (MOWP)

USA and Canada

This device complies with FCC Part 15 and Industry Canada license exempt RSS standard(s). Operation is subject to the following two conditions:

1. this device may not cause interference, and
2. this device must accept any interference, including interference that may cause undesired operation of the device.

This equipment has been tested and found to comply with the limits for a Class B digital device, pursuant to part 15 of the FCC Rules. These limits are designed to provide reasonable protection against harmful interference in a residential installation. This equipment generates, uses and can radiate radio frequency energy and, if not installed and used in accordance with the instructions, may cause harmful interference to radio communications. However, there is no guarantee that interference will not occur in a particular installation. If this equipment does cause harmful interference to radio or television reception, which can be determined by turning the equipment off and on, the user is encouraged to try to correct the interference by one or more of the following measures:

- Reorient or relocate the receiving antenna.
- Increase the separation between the equipment and receiver.
- Connect the equipment into an outlet on a circuit different from that to which the receiver is connected.

- Consult the dealer or an experienced radio/TV technician for help.

The device has been evaluated to meet general RF exposure requirement. The device can be used in portable exposure condition without restriction.

Le dispositif a été évalué à satisfaire l'exigence générale de l'exposition aux rf. L'appareil peut être utilisé dans des conditions d'exposition portatif sans restriction.

L'émetteur/récepteur exempt de licence contenu dans le présent appareil est conforme aux CNR d'Innovation, Sciences et Développement économique Canada applicables aux appareils radio exempts de licence.

1. l'appareil ne doit pas produire de brouillage, et
2. l'appareil doit accepter tout brouillage radioélectrique subi, même si le brouillage est susceptible d'en compromettre le fonctionnement.

Changes or modifications not expressly approved by the party responsible for compliance could void the user's authority to operate the equipment.

IC: 12006A-1001301698 For variant 1001298626

FCC ID: 2ACER1001301698 For variant 1001298626

Mexico

IFETEL



Marca: BRP Megatech

Número: BRME1023-28175

BRP Megatech Certificate number : 1451074

Modelo: 1001298626

NOM-208-SCFI-2016 (Disposición Técnica IFT-008-2015)

La operación de este equipo está sujeta a las siguientes dos condiciones:

1. Es posible que este equipo o dispositivo no cause interferencia perjudicial y
2. Este equipo o dispositivo debe aceptar cualquier interferencia, incluyendo la que pueda causar su operación no deseada.

Brazil



Número: 05248-23-15603

BRP Megatech Certificate number: 1451077

Modelo: 1001298626

Este equipamento não tem direito à proteção contra interferência prejudicial e não pode causar interferência em sistemas devidamente autorizados. Para maiores informações, consulte o site da ANATEL.

Japan

This device is granted pursuant to the Japanese Radio Law (電波法) and the Japanese Telecommunications Business Law (電気通信事業法). This device should not be modified (otherwise the granted designation number will become invalid).

Europe

Declaration of Conformity

Simplified EU Declaration of Conformity according Radio Equipment Directive 2014/ 53/ EU



DE

Hiermit erklärt BRP Megatech, dass der Funkanlagentyp 1001316154 der Richtlinie 2014/ 53/EU entspricht. Der vollständige Text der EU-Konformitätserklärung ist unter der folgenden Internetadresse verfügbar: <https://www.brp.com/en/corporate-social-responsibility/product-safety.html>

FR

Le soussigné, BRP Megatech, déclare que l'équipement radio-électrique du type 1001316154 est conforme à la directive 2014/53/UE. Le texte complet de la déclaration UE de conformité est disponible à l'adresse internet suivante: <https://www.brp.com/en/corporate-social-responsibility/product-safety.html>

BG

С настоящото BRP Megatech декларира, че този тип радиосъоръжение 1001316154 е в съответствие с Директива 2014/53/ЕС.

Цялостният текст на ЕС декларацията за съответствие може да се намери на следния интернет адрес: <https://www.brp.com/en/corporate-social-responsibility/product-safety.html>

EL

Με την παρούσα ο/η BRP Megatech, δηλώνει ότι ο ραδιοεξοπλισμός 1001316154 πληροί την οδηγία 2014/53/ΕΕ. Το πλήρες κείμενο της δήλωσης συμμόρφωσης ΕΕ διατίθεται στην ακόλουθη ιστοσελίδα στο διαδίκτυο: <https://www.brp.com/en/corporate-social-responsibility/product-safety.html>

CS

Tímto BRP Megatech prohlašuje, že typ rádiového zařízení 1001316154 je v souladu se směrnicí 2014/53/EU. Úplné znění EU prohlášení o shodě je k dispozici na této internetové adrese: <https://www.brp.com/en/>

[corporate-social-responsibility/product-safety.html](https://www.brp.com/en/corporate-social-responsibility/product-safety.html)

DA

Hermed erklærer BRP Megatech, at radioudstyrstypen 1001316154 er i overensstemmelse med direktiv 2014/53/EU.

EU-overensstemmelseserklæringens fulde tekst kan findes på følgende internetadresse: <https://www.brp.com/en/corporate-social-responsibility/product-safety.html>

ET

Käesolevaga deklareerib BRP Megatech, et käesolev raadioseadme tüüp 1001316154 vastab direktiivi 2014/53/EL nõuetele.

ELi vastavusdeklaratsiooni täielik tekst on kättesaadav järgmisel internetiaadressil: <https://www.brp.com/en/corporate-social-responsibility/product-safety.html>

ES

Por la presente, BRP Megatech declara que el tipo de equipo radioeléctrico 1001316154 es conforme con la Directiva 2014/53/UE.

El texto completo de la declaración UE de conformidad está disponible en la dirección Internet siguiente: <https://www.brp.com/en/corporate-social-responsibility/product-safety.html>

FI

BRP Megatech vakuuttaa, että radiolaitetyypin 1001316154 on direktiivin 2014/53/EU

mukainen. EU-vaatimustenmukaisuusvakuutuksen täysimittainen teksti on saatavilla seuraavassa internetosoitteessa: <https://www.brp.com/en/corporate-social-responsibility/product-safety.html>

EN

Hereby, BRP Megatech declares that the radio equipment type 1001316154 is in compliance with Directive 2014/53/EU. The full text of the EU declaration of conformity is available at the following internet address: <https://www.brp.com/en/corporate-social-responsibility/product-safety.html>

HR

BRP Megatech ovime izjavljuje da je radijska oprema tipa 1001316154 u skladu s Direktivom 2014/53/EU. Cjeloviti tekst EU izjave o sukladnosti dostupan je na sljedećoj internetskoj adresi: <https://www.brp.com/en/corporate-social-responsibility/product-safety.html>

HU

BRP Megatech igazolja, hogy a 1001316154 típusú rádióberendezés megfelel a 2014/53/EU irányelvnek. Az EU-megfelelőségi nyilatkozat teljes szövege elérhető a következő internetes címen: <https://www.brp.com/en/corporate-social-responsibility/product-safety.html>

IT

Il fabbricante, BRP Megatech, dichiara che il tipo di apparecchiatura radio 1001316154 è

conforme alla direttiva 2014/53/UE.

Il testo completo della dichiarazione di conformità UE è disponibile al seguente indirizzo Internet: <https://www.brp.com/en/corporate-social-responsibility/product-safety.html>

LT

Aš, BRP Megatech, patvirtinu, kad radijo įrenginių tipas 1001316154 atitinka Direktyvą 2014/53/ES. Visas ES atitikties deklaracijos tekstas prieinamas šiuo interneto adresu: <https://www.brp.com/en/corporate-social-responsibility/product-safety.html>

LV

Ar šo BRP Megatech deklarē, ka radioiekārta 1001316154 atbilst Direktīvai 2014/53/ES. Pilns ES atbilstības deklarācijas teksts ir pieejams šādā interneta vietnē: <https://www.brp.com/en/corporate-social-responsibility/product-safety.html>

MT

B'dan, BRP Megatech, niddikjara li dan it-tip ta' tagħmir tar-radjju 1001316154 huwa konformi mad-Direttiva 2014/53/UE. It-test kollu tad-dikjarazzjoni ta' konformità tal-UE huwa disponibbli f'dan l-indirizz tal-Internet li ġej: <https://www.brp.com/en/corporate-social-responsibility/product-safety.html>

NL

Hierbij verklaar ik, BRP Megatech, dat het type radioapparatuur 1001316154 conform is met Richtlijn 2014/53/EU.

De volledige tekst van de EU--conformiteitsverklaring kan worden geraadpleegd op het volgende internetadres: <https://www.brp.com/en/corporate-social-responsibility/product-safety.html>

PL

BRP Megatech niniejszym oświadcza, że typ urządzenia radiowego 1001316154 jest zgodny z dyrektywą 2014/53/UE. Pełny tekst deklaracji zgodności UE jest dostępny pod następującym adresem internetowym: <https://www.brp.com/en/corporate-social-responsibility/product-safety.html>

PT

O (a) abaixo assinado (a) BRP Megatech declara que o presente tipo de equipamento de rádio 1001316154 está em conformidade com a Diretiva 2014/53/UE.

O texto integral da declaração de conformidade está disponível no seguinte endereço de Internet: <https://www.brp.com/en/corporate-social-responsibility/product-safety.html>

RO

Prin prezenta, BRP Megatech declară că tipul de echipamente radio 1001316154 este în conformitate cu Directiva 2014/53/UE. Textul integral al declarației UE de conformitate este disponibil la următoarea adresă internet: <https://www.brp.com/en/corporate-social-responsibility/product-safety.html>

SV

Härmed försäkras BRP Megatech att denna typ av radioutrustning 1001316154 överensstämmer med direktiv 2014/53/EU. Den fullständiga texten till EU-försäkran om överensstämmelse finns på följande webbadress: <https://www.brp.com/en/corporate-social-responsibility/product-safety.html>

SL

BRP Megatech potrjuje, da je tip radijske opreme 1001316154 skladen z Direktivo 2014/53/EU. Celotno besedilo izjave EU o skladnosti je na voljo na naslednjem spletnem naslovu: <https://www.brp.com/en/corporate-social-responsibility/product-safety.html>

SK

BRP Megatech týmto vyhlasuje, že rádiové zariadenie typu 1001316154 je v súlade so smernicou 2014/53/EÚ. Úplné EÚ vyhlásenie o zhode je k dispozícii na tejto internetovej adrese: <https://www.brp.com/en/corporate-social-responsibility/product-safety.html>

IS

BRP Megatech lýsir því hér með yfir að þráðlausí fjarskiptabúnaðurinn 1001316154 er í samræmi við tilskipun 2014/53/ESB. Óstytta texta ESB-samræmisýfirlýsingarinnar er að finna á veffanginu: <https://www.brp.com/en/corporate-social-responsibility/product-safety.html>

Liechtenstein

Hiermit erklärt BRP Megatech, dass der Funkanlagentyp

1001316154 der Richtlinie 2014/53/EU entspricht. Der vollständige Text der EU-Konformitätserklärung ist unter der folgenden Internetadresse verfügbar: <https://www.brp.com/en/corporate-social-responsibility/product-safety.html>

NO

Hermed erklærer BRP Megatech at radioutstyrstypen 1001316154 er i samsvar med direktiv 2014/53/EU. Hele teksten i EU-samsvarserklæringen finnes på følgende internetadresse: <https://www.brp.com/en/corporate-social-responsibility/product-safety.html>

RU

Компания BRP Megatech настоящим заявляет, что радиотехническое оборудование категории 1001316154 отвечает требованиям Директивы 2014/53/EU.

Полный текст декларации соответствия ЕС доступен на сайте <https://www.brp.com/en/corporate-social-responsibility/product-safety.html>

RADIO FREQUENCY DIGITALLY ENCODED SECURITY SYSTEM (RF D.E.S.S. KEY)

This device complies with FCC Part 15 and Industry Canada license exempt RSS standard(s).

Operation is subject to the following two conditions: (1) this device may not cause interference, and (2) this device must accept any interference, including interference that may cause undesired operation of the device.

Changes or modifications not expressly approved by the party responsible for compliance could void the user's authority to operate the equipment.

IC Registration Number: 12006A-1001317030

FCC ID: 2ACER-1001317030

We, the party responsible for compliance, declare under our sole responsibility that the device is in conformity with the provisions of the following Council Directive: 2014/53/EU. To which this declaration relates is in conformity with the essential requirements and other relevant requirements. The product is in conformity with the following directives, harmonized standards and regulations:

Radio Equipment Directive (RED) 2014/53/EU and Harmonized Standards:

IEC 62368-1:2014, CISPR 25:2016, ISO 11452-2:2004, ETSI EN 300 330 V2.1.1:2017

Radio Equipment Statutory Instrument 2017/1206 and Designated Standards:

IEC 62368-1:2014, CISPR 25:2016, ISO 11452-2:2004, ETSI EN 300 330 V2.1.1:2017

TECHNICAL SPECIFICATIONS

ENGINE

ENGINE	
Engine type	Rotax 600 E-TEC® RS Liquid cooled with reed valves and electronic RAVE
Number of cylinder	2
Bore	72.3 mm (2.846 in)
Stroke	73.0 mm (2.874 in)
Displacement	599.4 cm ³ (36.58 in ³)
Maximum power engine speed	8500 ± 100 RPM

FUEL/ LUBRICATION SYSTEM	
Fuel delivery	E-TEC direct injection with integrated auxiliary injection system
Idle speed (not adjustable)	1600 ± 200 RPM
Gasoline/oil ratio	33:1
Pre-mix oil	Recommended XPS 2T X2-RS racing synthetic oil
Water pump shaft oil	
Water pump shaft oil reservoir capacity	50 ml (1.7 fl oz(US))

ELECTRICAL SYSTEM	
Lighting system output	30 A @ 14.5 V 1340 W @ 6000 RPM
Spark plug	Type NGK ILKR9Q7 (engine and spark plug threads are indexed)

ELECTRICAL SYSTEM		
	Gap	Not adjustable 0.6 to 0.7 mm (.024 to .028 in)

VEHICLE

COOLING SYSTEM			
Coolant	Type	Recommended	XPS Extended life pre-mixed coolant
		Alternative, or if not available	Distilled water and antifreeze solution (50% distilled water, 50% antifreeze)

FUEL SYSTEM			
Fuel pump		In-tank electrical fuel pump	
Fuel	Type	Premium unleaded gasoline (fuel which may contain up to 10% MAX ethanol)	
	Octane rating	91 Pump Posted AKI (R+M)/2 95 (RON)	
Fuel tank capacity		19 l (5 gal(liq.,US))	

ELECTRICAL SYSTEM			
Headlamp		15 W Projector LED	
Taillight and stoplight		2.6 W / 139 m W LED	
Fuses	F1	Start/RER/ Clock	5 A
	F2	Loads	25 A
	F4	Accessory	15 A

DRIVE SYSTEM - CHAINCASE		
Chaincase oil	Type	XPS Synthetic chaincase oil

DRIVE SYSTEM – CHAINCASE		
	Capacity	350 ml (12 fl oz(US))
Chaincase ratio		22/51

DRIVE SYSTEM – PULLEYS		
Drive pulley	Type	Racing pDrive
	Engagement RPM	5300 ± 100 RPM
Driven pulley	Type	Team Rapid Reaction
Drive belt adjustment	Deflection	27 to 37 mm (1.06 to 1.46 in)
	Force	11.3 kg (25 lb)

DRIVE SYSTEM – TRACK		
Drive sprocket number of teeth		8
Track	Width	38 cm (15 in)
	Length	348 cm (137 in)
	Profile height	44.5 mm (1.75 in)
Track adjustment	Deflection	3.7 cm (1.46 in)
	Force	6.0 to 8.5 kgf (13 to 19 lbf)

BRAKE SYSTEM		
Brake	Type	Single 220 mm stainless floating disc with 4 pistons caliper
Brake fluid	Type	DOT 4
	Quantity	50 ml (1.69 fl oz(US))
Caliper		Fixed 4 pistons (4 x 30 mm)
Brake pad material		Metallic
Minimum brake pad thickness		0.5 mm (.02 in)
Minimum brake disc thickness		5.4 mm (.213 in)
Maximum brake disc warpage		0.2 mm (.01 in)

FRONT SUSPENSION	
Suspension type	RAS 3 RS
Suspension maximum travel	234 mm (9.2 in)
Shock absorber type	KYB PRO 46 INT R

REAR SUSPENSION		
Suspension type		rMotion Racing
Suspension maximum travel Measured at rear arm		272 mm (10.7 in)
Shock absorber type	Center	KYB PRO 46 INT
	Rear	KYB PRO 46 INT R

WEIGHT AND DIMENSIONS		
Mass (dry)	Inside North America	213.6 kg (470.9 lb)
	Outside North America	218.1 kg (480.8 lb)
Overall length		3 038 mm (119.6 in)
Overall width		1 275 mm (50.2 in)
Overall height		1 200 mm (47.2 in)
Ski stance		1 094 mm (43.1 in)

This page is intentionally blank

TROUBLESHOOT- ING

TROUBLESHOOTING GUIDELINES

Troubleshooting

1. ENGINE IS CRANKED BUT FAILS TO START

No fuel to the engine.

- *Check fuel tank level, add fuel if necessary.*

System voltage too low.

- *Contact an authorized Ski-Doo dealer.*

2. ENGINE LACKS ACCELERATION OR POWER

Engine warm-up in progress.

- *Drive vehicle at low speeds for a few minutes.*

Engine break-in period not completed.

- *Complete break-in period.*

Drive and driven pulleys require servicing.

- *Contact an authorized SKI-DOO dealer.*

Engine overheats.

- *Check coolant level, see MAINTENANCE PROCEDURES (PAGE 152) MAINTENANCE PROCEDURES.*
- *Check heat exchangers cleanliness. Clean if necessary.*

Drive belt worn too thin.

- *If the drive belt has lost more than 3 mm (1/8 in) of its original width, it will affect vehicle performance.*
- *Replace drive belt.*

Incorrect track adjustment.

- *See MAINTENANCE PROCEDURES (PAGE 152) MAINTENANCE PROCEDURES and/or an authorized SKI-DOO dealer for proper alignment and tension adjustments.*

R.A.V.E. valves problem.

- *Seek service from an authorized Ski-Doo dealer, repair shop, or person of your own choosing for maintenance, repair, or replacement.*

Fuel pressure too low.

- *Seek service from an authorized Ski-Doo dealer, repair shop, or person of your own choosing for maintenance, repair, or replacement.*

3. ENGINE BACKFIRES

Engine is running too hot.

- *See item 4 of ENGINE LACKS POWER.*

Ignition timing is incorrect or there is an ignition system failure.

- *Seek service from an authorized Ski-Doo dealer, repair shop, or person of your own choosing for maintenance, repair, or replacement.*

Exhaust system leak.

- *Seek service from an authorized Ski-Doo dealer, repair shop, or person of your own choosing for maintenance, repair, or replacement.*

Fuel pressure too low.

- *Seek service from an authorized Ski-Doo dealer, repair shop, or person of your own choosing for maintenance, repair, or replacement.*

4. ENGINE MISFIRES

Water in fuel.

- *Drain fuel system and refill with fresh fuel.*

RAVE valves malfunction.

- *Have RAVE valves system inspected. Seek service from an authorized Ski-Doo dealer, repair shop, or person of your own choosing for maintenance, repair, or replacement.*

5. HEATED GRIPS/THUMB WARMERS ARE NOT WORKING

Engine RPM is too low.

- *Make sure engine RPM is above 2000.*

6. ENGINE HAS SHUT DOWN

The engine shuts down after long periods of idling.

- *Do not let engine idle too long. Refer to VEHICLE WARM-UP in operating instruction.*

7. WATER PUMP SHAFT OIL LEVEL LOWERS

External leak.

- *Replace leaking part.*

Engine internal leak.

- *Have the engine bottom end repaired .*

MONITORING SYSTEM

Icons, Messages and Beeper Codes

The gauge icons inform you of an anomaly or a particular condition.

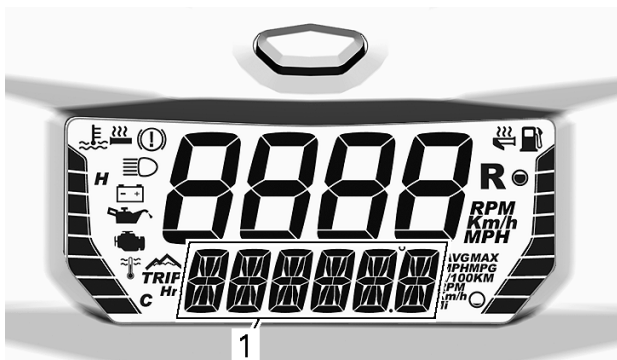

Icons can come on or blink alone or in combination with others.





1. Lower display

In addition to the icons, messages are displayed along with a beep code.

See following table for details.

Icon ON	Beeper	Message	Description
	4 short beeps every 30 seconds	ENGINE OVERHEAT	Engine is overheating, reduce snowmobile speed and run in loose snow or stop engine immediately and let engine cool down. Check coolant level, refer to <i>Maintenance</i> . If coolant level is correct and overheating persists, contact an authorized Ski-Doo dealer. Do not run the engine if condition persists.
		MUFFLER	Reduce speed or stop engine. Let engine cool down and restart. If overheating persists, contact an authorized Ski-Doo dealer. Do not run the engine if condition persists.
		ECM	
	Short beeps repeating rapidly	OVERHEAT In combination with "ENGINE OVER HEAT" above	Critical overheating. Stop engine immediately and let engine cool down. Check coolant level, refer to <i>Maintenance</i> . If coolant level is correct and overheating persists, contact an authorized Ski-Doo dealer. Do not run the engine if condition persists.
		OVERHEAT In combination with "MUFFLER" OR "ECM"	Critical overheating. Stop engine immediately and let engine cool down. If overheating persists, contact an authorized Ski-Doo dealer. Do not run the engine if condition persists.

Icon ON	Beeper	Message	Description
	4 short beeps	CHECK ENGINE	Engine fault, see an authorized Ski-Doo dealer, repair shop or person of your own choosing as soon as possible.
 (blinking)	4 short beeps	—	Displayed when brake is applied for more than 15 seconds while throttle lever is squeezed and vehicle is moving at more than 5 km/h (3 MPH).
—	4 short beeps every 8 seconds	KNOCK	Engine detonation (RPM is limited when this condition occurs). <ul style="list-style-type: none"> – Ensure recommended fuel is used. – Check fuel quality, replace if necessary. – If fault still occurs, contact an authorized Ski-Doo dealer, repair shop, or person of your own choosing.
—	4 short beeps every 5 minutes	REV LIMIT	Engine RPM limited for protection when certain faults occur.
—	—	OVER REV	Indicates that maximum engine RPM is reached. Check clutch calibration.

Icon ON	Beeper	Message	Description
—	Short beeps repeating rapidly	SHUT DOWN	Shutdown procedure in force due to engine overheating or fuel pump problem.
—	—	COMMUNICATION	Communication problem between ECM and gauge. Stop engine, remove tether cord cap. Wait a few minutes, then start engine. If problem persists, contact an authorized Ski-Doo dealer.

Fault Codes

If the check engine icon is ON, it is possible to read fault code(s) on the gauge.

To read active fault code(s), select the vehicle speed and engine RPM display combination, see *Compact Digital Display*.

NOTE:

Make sure to select actual vehicle speed and actual engine RPM (not "top" or "average" values).

Press and hold the gauge mode button and simultaneously switch from HIGH to LOW beam repeatedly several times until a code is displayed.

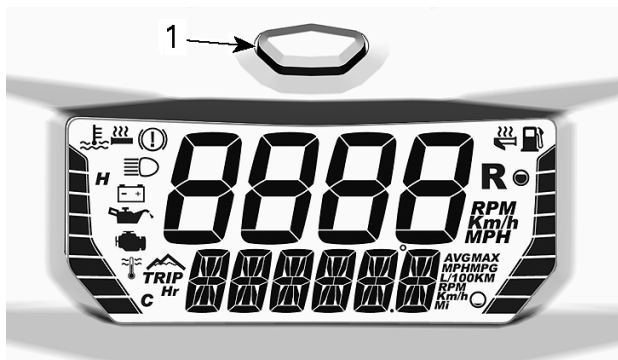

1. Gauge mode button

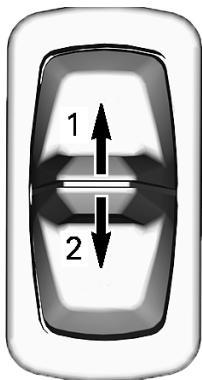

1. High beam
2. Low beam

If two or more codes are registered, use the gauge mode button to scroll.

To exit the fault codes mode, press and hold the gauge mode button.

Contact an authorized Ski-Doo dealer for code signification.

BRP LIMITED WARRANTY USA AND CANADA: 2025 SKI-DOO® SNOWMOBILES

THE PRODUCT IS DESIGNED FOR SPECIFIC RACING FUNCTIONALITIES AND IS NOT DESIGNED OR CERTIFIED TO BE OPERATED ON SNOWMOBILE TRAILS. TO THE EXTENT PERMITTED BY LAW, NO WARRANTY, EXPRESSED OR IMPLIED, INCLUDING WITHOUT LIMITATION ANY WARRANTY OF MERCHANTABILITY OR FITNESS FOR A PARTICULAR PURPOSE IS HEREBY GIVEN BY BRP. TO THE EXTENT THAT THEY CANNOT BE DISCLAIMED, THE IMPLIED WARRANTIES ARE LIMITED TO THE MINIMUM TERM PROVIDED AT LAW. SOME JURISDICTIONS DO NOT ALLOW FOR THE DISCLAIMED, LIMITATIONS AND EXCLUSIONS IDENTIFIED ABOVE. AS A RESULT, THEY MAY NOT APPLY TO YOU. THIS WARRANTY GIVES YOU SPECIFIC RIGHTS, AND YOU MAY ALSO HAVE OTHER LEGAL RIGHTS WHICH MAY VARY FROM JURISDICTION TO JURISDICTION.

BRP INTERNATIONAL LIMITED WARRANTY: 2025 SKI-DOO® SNOWMOBILES

THE PRODUCT IS DESIGNED FOR SPECIFIC RACING FUNCTIONALITIES AND IS NOT DESIGNED OR CERTIFIED TO BE OPERATED ON SNOWMOBILE TRAILS. TO THE EXTENT PERMITTED BY LAW, NO WARRANTY, EXPRESSED OR IMPLIED, INCLUDING WITHOUT LIMITATION ANY WARRANTY OF MERCHANTABILITY OR FITNESS FOR A PARTICULAR PURPOSE IS HEREBY GIVEN BY BRP. TO THE EXTENT THAT THEY CANNOT BE DISCLAIMED, THE IMPLIED WARRANTIES ARE LIMITED TO THE MINIMUM TERM PROVIDED AT LAW. SOME JURISDICTIONS DO NOT ALLOW FOR THE DISCLAIMED, LIMITATIONS AND EXCLUSIONS IDENTIFIED ABOVE. AS A RESULT, THEY MAY NOT APPLY TO YOU. THIS WARRANTY GIVES YOU SPECIFIC RIGHTS, AND YOU MAY ALSO HAVE OTHER LEGAL RIGHTS WHICH MAY VARY FROM JURISDICTION TO JURISDICTION.

BRP LIMITED WARRANTY FOR THE EUROPEAN ECONOMIC AND THE COMMONWEALTH OF THE INDEPENDENT STATES (CIS) AREAS AND TURKEY: 2025 SKI-DOO® SNOWMOBILES

THE PRODUCT IS DESIGNED FOR SPECIFIC RACING FUNCTIONALITIES AND IS NOT DESIGNED OR CERTIFIED TO BE OPERATED ON SNOWMOBILE TRAILS. TO THE EXTENT PERMITTED BY LAW, NO WARRANTY, EXPRESSED OR IMPLIED, INCLUDING WITHOUT LIMITATION ANY WARRANTY OF MERCHANTABILITY OR FITNESS FOR A PARTICULAR PURPOSE IS HEREBY GIVEN BY BRP. TO THE EXTENT THAT THEY CANNOT BE DISCLAIMED, THE IMPLIED WARRANTIES ARE LIMITED TO THE MINIMUM TERM PROVIDED AT LAW. SOME JURISDICTIONS DO NOT ALLOW FOR THE DISCLAIMED, LIMITATIONS AND EXCLUSIONS IDENTIFIED ABOVE. AS A RESULT, THEY MAY NOT APPLY TO YOU. THIS WARRANTY GIVES YOU SPECIFIC RIGHTS, AND YOU MAY ALSO HAVE OTHER LEGAL RIGHTS WHICH MAY VARY FROM JURISDICTION TO JURISDICTION.

This page is intentionally blank

CUSTOMER INFORMATION

DATA PRIVACY INFORMATION

Bombardier Recreational Products Inc., its affiliates and subsidiaries (“BRP”) is committed to protecting your privacy and support a general policy of openness about how we collect, use and disclose your personal information in the course of managing our relationship with you. **More details can be found by visiting BRP’s Privacy Policy at: <https://brp.com/en/privacy-policy.html> or by scanning the QR Code below.**

Please be assured that we have appropriate security measures in place to ensure that your personal information is protected against loss and unauthorized access.

Your personal information that may be collected by BRP, directly from you or from authorized dealers or authorized third parties, includes:

- **Contact, Demographic & Registration Information** (e.g., name, full address, phone number, email, gender, ownership history, language of communication)
- **Vehicle Information** (e.g., serial number, purchase and delivery date, unit usage, vehicle location and movements)
- **Third Party Information** (e.g., information received from BRP partners, joint marketing activities information, social media)
- **Technological Information** (e.g., IP address, type of device, operating system, browser type, webpages you view, cookies and similar technologies when you use BRP or dealers’ websites or mobile application)
- **Interaction with BRP Information** (e.g., information collected when you call BRP’s in-house sales representatives, buy items on a BRP website, sign up for BRP emails, participate in BRP-sponsored contests and sweepstakes or attend BRP-sponsored events)
- **Transactional Information** (e.g., information necessary to handle returns, payment information when you purchase our products or services through our websites or mobile applications and other issues related to your purchase of BRP products)

This information may be used and processed for the following purposes:

- Safety & Security
- Customer Support for Sales and After Sales (e.g., complete or follow up with you about your purchase or maintenance)
- Registration & Warranty
- Communication (e.g., sending you a BRP satisfaction survey)
- Online Behavioural Advertising, Profiling and Location-Based Services (e.g., offer customized experience)
- Compliance & Dispute Resolution
- Marketing & Advertising
- Assistance (e.g., help with any delivery issues, handle returns, and other issues related to your purchase of BRP products).

We also may use personal information to generate aggregated or statistical data that no longer identifies you personally.

Your personal information may be disclosed to the following: BRP, BRP's authorized dealerships, distributors, service providers, advertising and market research partners and other authorized third parties.

We may receive information about you from diverse sources, including third parties, such as BRP's authorized dealerships and partners, with whom we offer services or engage in joint-marketing activities. We may also receive information about you from social media platforms when you interact with us on those platforms.

Depending on the circumstances, your personal information may be communicated outside the region where you reside. Your personal information is retained only for as long as necessary for the purpose for which we obtained it and according to our retention policies.

To exercise your data privacy rights (e.g. right of access, right of rectification), to withdraw your consent in order to be removed from the address list for marketing purposes or for the satisfaction survey or for general data privacy questions, please contact BRP's Data Protection Officer at or by mail at privacyofficer@brp.com or by mail at: BRP Legal Service, 726 St-Joseph, Valcourt, Quebec, Canada, J0E 2L0.

When BRP processes your personal information, they do so in compliance with its Privacy Policy available at: <https://www.brp.com/en/privacy-policy.html> or by using the following QR Code.



CONTACT US

www.brp.com

Asia Pacific

BRP Asia

107D and 107E, 17/F, Tower 1,
Grand Century Place, Mongkok,
Kowloon, Hong Kong

Australia

Level 26
477 Pitt Street
Sydney, NSW 2020

China

上海市徐汇区衡山路10号6号楼301
Rm 301, Building 6,
No.10 Heng Shan Rd,
Shanghai, China

Japan

21F Shinagawa East One Tower
2-16-1 Konan, Minato-ku-ku,
Tokyo 108-0075

New Zealand

Suite 1.6, 2-8 Osborne Street,
Newmarket, Auckland 2013

Europe, Middle East and Africa

Belgium

Oktrooiplein 1
9000 Gent

Czech Republic

Stefanikova 43a
Prague 5
150 00

Germany

Alte Papierfabrik 16
D-40699 Erkrath

Finland

Isoaavantie 7
PL 8040
96101 Rovaniemi

France

Arteparc Bâtiment B
Route de la côte d'Azur,
13 590 Meyreuil

Norway

Ingvald Ystgaardsvei 15
N-7484 Trondheim
Salg, marketing, ettermarked

Sweden

Spinnvägen 15
903 61 Umeå
Sweden 90821

Switzerland

Avenue d'Ouchy 4-6
1006 Lausanne

Latin America

Brazil

Av. James Clerck Maxwell, 230
Campinas, Sao Paulo
CEP 13069-380

Mexico

Av. Ferrocarril 202
Parque Industrial Querétaro
Santo Rosa Jauregui, Querétaro
C.P. 76220

North America

Canada

3200A, rue King Ouest,
Suite 300
Sherbrooke (Québec) J1L 1C9

United States of America

10101 Science Drive
Sturtevant, Wisconsin
53177

CHANGE OF ADDRESS/OWNERSHIP

If your address has changed or if you are the new owner of the snowmobile, be sure to notify BRP by either:

- Notifying an authorized BRP snowmobile dealer or distributor.
- **North America Only:** calling at 1 888 272-9222.
- Mailing one of the change of address cards on the following pages at one of the BRP addresses indicated in the *Contact Us* section of this guide.

In case of change of ownership, please join a proof that the former owner agreed to the transfer.

Notifying BRP, even after the expiration of the limited warranty, is very important as it enables BRP to reach the snowmobile owner if necessary, like when safety recalls are initiated. It is the owner's responsibility to notify BRP.

STOLEN UNITS: If your personal snowmobile is stolen, you should notify BRP or an authorized BRP snowmobile dealer. We will ask you to provide your name, address, phone number, the vehicle identification number and the date it was stolen.

This page is
intentionally blank

This page is
intentionally blank



CHANGE OF ADDRESS CHANGE OF OWNERSHIP

VEHICLE IDENTIFICATION NUMBER

Model Number Vehicle Identification Number (V.I.N.)

OLD ADDRESS
OR PREVIOUS OWNER:

NAME

NO. STREET APT

CITY STATE/PROVINCE ZIP/POSTAL CODE

COUNTRY TELEPHONE

NEW ADDRESS
OR NEW OWNER:

NAME

NO. STREET APT

CITY STATE/PROVINCE ZIP/POSTAL CODE

COUNTRY TELEPHONE

E-MAIL ADDRESS

This page is
intentionally blank

This page is
intentionally blank

Model No. _____

VEHICLE

IDENTIFICATION NUMBER (V.I.N.) _____

ENGINE

IDENTIFICATION NUMBER (E.I.N.) _____

Owner: _____

NAME

No. _____ STREET _____ APT _____

CITY _____ STATE/PROVINCE _____ ZIP/POSTAL CODE _____

Purchase Date _____
YEAR MONTH DAY**Warranty Expiry Date** _____
YEAR MONTH DAY

To be completed by the dealer at the time of the sale.

DEALER IMPRINT AREA

This page is intentionally blank

⚠ WARNING

Disregarding any of the safety precautions and instructions contained in the Operators's Guide, SAFETY VIDEO and on product safety labels could cause injury including the possibility of death.



®TM and the BRP logo are trademarks of BOMBARDIER RECREATIONAL PRODUCTS INC. or its affiliates.

©2024 BOMBARDIER RECREATIONAL PRODUCTS INC. ALL RIGHTS RESERVED.

www.brp.com

ALUMACRAFT®

CAN-AM®

LYNX®

MANITOU®

QUINTREX®

ROTAX®

SEA-DOO®

SKI-DOO®