

**can-am**



Renegade™ 70

Renegade 110 / Renegade 110 X xc

# OPERATOR'S GUIDE

Includes Safety, Use and Maintenance  
Information

**REN  
E  
G  
A  
D  
E**

## **⚠ WARNING**

Category Y ATV, always follow this age recommendation under adult supervision

– Age 6 or older for Renegade 70

– Age 10 or older for Renegade 110 and Renegade 110 Xxc

Read this operator's guide thoroughly. It contains important safety information.

Adult supervision is required for the proper understanding of the risks involved with the usage of these vehicles.

Review and explain the content of this operator's guide with the young operator and make sure that the young operator understands the proper safe operation of the vehicle.

The removal or modification of evaporative emission-related parts on this OHRV is illegal.

Violators may be subject to civil and/or criminal penalties under California and federal law.

Keep this operator's guide with the vehicle at all times.

**219002438**

**Original Instructions**

 **WARNING**

**YOUR VEHICLE CAN BE HAZARDOUS TO OPERATE.** A collision or rollover can occur quickly, if you fail to take proper precautions, even during routine maneuvers such as turning and driving on hills or over obstacles.

For your safety, understand and follow all the warnings contained in this operator's guide and on the labels on your vehicle. Failure to follow these warnings can result in **SEVERE INJURY OR DEATH.**

Keep this operator's guide with the vehicle at all times.

 **WARNING**

Disregarding any of the safety precautions and instructions contained in this Operators's Guide, safety video and on product safety labels could cause injury including the possibility of death.

## **CALIFORNIA PROPOSITION 65 WARNING**

 **WARNING**

Operating, servicing and maintaining an off-road vehicle can expose you to chemicals including engine exhaust, carbon monoxide, phthalates, and lead, which are known to the State of California to cause cancer and birth defects or other reproductive harm. To minimize exposure, avoid breathing exhaust, do not idle the engine except as necessary, service your vehicle in a well-ventilated area and wear gloves or wash your hands frequently when servicing your vehicle. For more information go to [www.p65warnings.ca.gov/products/passenger-vehicle](http://www.p65warnings.ca.gov/products/passenger-vehicle).

TM® Trademarks of BRP or its affiliates.

This is a non-exhaustive list of trademarks that are the property of Bombardier Recreational Products Inc. or its affiliates.

Trademarks may not be registered in every jurisdictions.

Can-Am®

Renegade™

XPS®

All rights reserved. No parts of this Operator's Guide may be reproduced in any form without the prior written permission of Bombardier Recreational Products Inc.

©Bombardier Recreational Products Inc. (BRP) 2024

Deutsch	Dieses Handbuch ist möglicherweise in Ihrer Landessprache verfügbar. Bitte wenden Sie sich an Ihren Händler oder besuchen Sie: <a href="http://www.operatorsguides.brp.com">www.operatorsguides.brp.com</a>
English	This guide may be available in your language. Check with your dealer or go to: <a href="http://www.operatorsguides.brp.com">www.operatorsguides.brp.com</a>
Español	Es posible que este manual esté disponible en su idioma. Consulte a su distribuidor o visite: <a href="http://www.operatorsguides.brp.com">www.operatorsguides.brp.com</a>
Français	Ce guide peut être disponible dans votre langue. Vérifier avec votre concessionnaire ou aller à: <a href="http://www.operatorsguides.brp.com">www.operatorsguides.brp.com</a>
Italiano	Questa guida potrebbe essere disponibile nella propria lingua. Contattare il concessionario o consultare: <a href="http://www.operatorsguides.brp.com">www.operatorsguides.brp.com</a>
中文	本手册可能有您的语种的翻译版本。请向经销商询问，或者登录 <a href="http://www.operatorsguides.brp.com">www.operatorsguides.brp.com</a> 查询。
日本語	このガイドは、言語によって翻訳版が用意されています。ディーラーに問い合わせるか、次のアドレスでご確認ください： <a href="http://www.operatorsguides.brp.com">www.operatorsguides.brp.com</a>
Nederlands	Deze handleiding kan beschikbaar zijn in uw taal. Vraag het aan uw dealer of ga naar: <a href="http://www.operatorsguides.brp.com">www.operatorsguides.brp.com</a>
Norsk	Denne boken kan finnes tilgjengelig på ditt eget språk. Kontakt din forhandler eller gå til: <a href="http://www.operatorsguides.brp.com">www.operatorsguides.brp.com</a>
Português	Este manual pode estar disponível em seu idioma. Fale com sua concessionária ou visite o site: <a href="http://www.operatorsguides.brp.com">www.operatorsguides.brp.com</a>
Русский	Воспользуйтесь руководством на вашем языке. Узнайте о его наличии у дилера или на странице по адресу <a href="http://www.operatorsguides.brp.com">www.operatorsguides.brp.com</a>
Suomi	Käyttöohjekirja voi olla saatavissa omalla kielelläsi. Tarkista jälleenmyyjältä tai käy osoitteessa: <a href="http://www.operatorsguides.brp.com">www.operatorsguides.brp.com</a>
Svenska	Denna bok kan finnas tillgänglig på ditt språk. Kontakta din återförsäljare eller gå till: <a href="http://www.operatorsguides.brp.com">www.operatorsguides.brp.com</a>

Covered Models
Renegade 70 Renegade 110 Renegade 110 Xxc

In Canada, products are distributed and serviced by Bombardier Recreational Products Inc. (BRP).

In the USA, products are distributed and serviced by BRP US Inc.

In the European Economic Area (which is comprised of the member states of the European Union plus the United Kingdom, Norway, Iceland and Liechtenstein), the Commonwealth of the Independent States (including Ukraine and Turkmenistan) and Turkey, products are distributed and serviced by BRP European Distribution S.A. and other affiliates or subsidiaries of BRP.

For all other countries, products are distributed and serviced by Bombardier Recreational Products Inc. (BRP) or its affiliates.

While reading this Operator's Guide, remember that:

 **WARNING**

**Indicates a potential hazard which, if not avoided, could result in serious injury or death.**

---

# TABLE OF CONTENTS

## GENERAL INFORMATION

<b>GENERAL INFORMATION</b> .....	<b>8</b>
Know Before you Go .....	8
Safety Messages .....	9
Notice to Parents .....	9
About this Operator's Guide .....	10

## SAFETY INFORMATION

<b>GENERAL PRECAUTIONS</b> .....	<b>14</b>
Avoid Carbon Monoxide Poisoning .....	14
Avoid Gasoline Fires and Other Hazards .....	14
Avoid Burns from Hot Parts .....	14
Accessories and Modifications .....	15
<b>SPECIAL SAFETY MESSAGES</b> .....	<b>16</b>
<b>OPERATION WARNINGS</b> .....	<b>19</b>
Age Recommendations .....	20
Carrying a Passenger .....	21
Riding Without Protective Gear .....	24
Drugs or Alcohol .....	25
Excessive Speeds .....	26
Proper Position on the Vehicle .....	29
Unfamiliar Terrain .....	30
Operating on Excessively Rough, Slippery or Loose Terrain .....	31
Turning Improperly .....	32
Excessively Steep Hills .....	33
Climbing Hills .....	34
Down a Hill .....	35
Crossing or Turning on Hills .....	36
Stalling, Rolling Backwards or Dismounting While Climbing a Hill .....	37
Operating Over Obstacles .....	38
Skidding or Sliding .....	39
Operating in Reverse .....	42
Improper Modifications .....	45
Loading, Carrying or Towing Cargo .....	46
<b>PRE-RIDE INSPECTION</b> .....	<b>50</b>
Pre-Ride Inspection Check List .....	50
<b>RIDING THE VEHICLE</b> .....	<b>53</b>
Riding Gear .....	54
Carrying a Passenger is Prohibited .....	55
Carrying Loads .....	56
Recreational Riding .....	56
Environment .....	57
Design Limitation .....	57
Off-Road Operation .....	57
Riding Techniques .....	58

---

TABLE OF CONTENTS

<b>IMPORTANT ON-PRODUCT LABELS (CANADA/UNITED STATES)</b> .....	<b>68</b>
Safety Hang Tag .....	68
Safety Labels .....	69
Molded Pictogram .....	76
Compliance Hang Tag .....	77
<b>IMPORTANT ON-PRODUCT LABELS (ALL COUNTRIES OUTSIDE CANADA/UNITED STATES)</b> .....	<b>78</b>
Hang Tag .....	78
Safety Pictogram .....	80
Molded Pictogram .....	86
<b>REPORTING SAFETY DEFECTS</b> .....	<b>87</b>

**VEHICLE INFORMATION**

<b>PRIMARY CONTROLS</b> .....	<b>90</b>
Throttle Lever .....	90
RH Brake Lever .....	93
LH Brake Lever .....	94
Parking Brake .....	95
<b>SECONDARY CONTROLS</b> .....	<b>98</b>
Transmission Lever .....	98
Multifunction Switch .....	99
Indicator Lamps .....	102
Ignition Switch .....	103
<b>EQUIPMENT</b> .....	<b>105</b>
Seat .....	105
<b>FUEL</b> .....	<b>107</b>
Fuel Requirements .....	107
Fueling Procedure .....	108
<b>BREAK-IN PERIOD</b> .....	<b>110</b>
Operating During Break-In .....	110
<b>OPERATING INSTRUCTIONS</b> .....	<b>111</b>
Starting the Engine .....	111
Stopping the Engine .....	113
Shifting the Transmission .....	114
<b>TUNE YOUR RIDE</b> .....	<b>115</b>
Adjusting the Suspension .....	115
<b>VEHICLE TRANSPORTATION</b> .....	<b>118</b>

**MAINTENANCE**

<b>MAINTENANCE SCHEDULE</b> .....	<b>122</b>
EPA Regulation - Canadian and USA Vehicles .....	122
Severe Dusty Conditions .....	122
Maintenance Schedule .....	123

**MAINTENANCE PROCEDURES** ..... 127

- Engine Oil..... 127
- AIR FILTER ..... 132
- AIR FILTER HOUSING ..... 135
- Spark Arrester..... 136
- Exhaust System..... 137
- CVT Cover..... 138
- Gearbox Oil..... 139
- Throttle Cable ..... 141
- Spark Plug..... 144
- Battery ..... 146
- Fuse ..... 148
- Lights..... 149
- Drive Chain, Roller and Sprockets ..... 151
- WHEEL BEARING..... 156
- Tires and Wheels ..... 157
- Steering System ..... 160
- Suspension..... 161
- Brakes ..... 162

**TECHNICAL INFORMATION**

**VEHICLE IDENTIFICATION** ..... 168

- Vehicle Identification Number (VIN) Location..... 169
- Engine Identification Number (EIN) Location ..... 170

**COMPLIANCE HANG TAG** ..... 171

- Compliance Hang Tag ..... 171

**COMPLIANCE LABELS** ..... 172

- ANSI/SVIA Conformity ..... 172
- Emission Control Information..... 173
- US CPSC Conformity ..... 174
- Percentage of Ethanol..... 175

**EVAPORATIVE EMISSION CONTROL SYSTEM**..... 176

- California Models with Evaporative Emission Control System. 176

NOISE EMISSION CONTROL SYSTEM REGULATION (CANADA/UNITED STATES) .....	177
EC DECLARATION OF CONFORMITY .....	178
UK DECLARATION OF CONFORMITY .....	179

### **TECHNICAL SPECIFICATIONS**

TECHNICAL SPECIFICATIONS .....	182
--------------------------------	-----

### **TROUBLESHOOTING**

TROUBLESHOOTING GUIDELINES .....	190
Troubleshooting .....	190

### **WARRANTY**

BRP LIMITED WARRANTY CANADA AND USA: 2025 CAN-AM® YOUTH ATV .....	196
US EPA EMISSION – RELATED WARRANTY .....	200
CALIFORNIA EVAPORATIVE EMISSIONS CONTROL WARRANTY STATEMENT .....	203
BRP INTERNATIONAL LIMITED WARRANTY: 2025 CAN-AM® YOUTH ATV .....	207
BRP LIMITED WARRANTY FOR THE EUROPEAN ECONOMIC AREAS, THE COMMONWEALTH OF THE INDEPENDENT STATES, RUSSIA AND TURKEY: 2025 CAN-AM® YOUTH ATV .....	212

### **CUSTOMER INFORMATION**

DATA PRIVACY INFORMATION .....	218
CONTACT US .....	220
Asia Pacific .....	220
Europe, Middle East and Africa .....	220
Latin America .....	221
North America .....	221
CHANGE OF ADDRESS AND OWNERSHIP .....	222



# **GENERAL INFORMATION**

---

## GENERAL INFORMATION

Congratulations on your purchase of a new Can-Am® Youth ATV vehicle. Your new vehicle is backed by the BRP limited warranty and a network of authorized Can-Am Off-road dealers ready to provide the parts, accessories or service you may require.

At delivery, you were informed of the warranty coverage and signed the Pre-delivery Check List to ensure that your vehicle was prepared to your entire satisfaction.

Your dealer is committed to your satisfaction. If you need more information, please ask your dealer.

### Know Before you Go

To learn how to reduce the risk of accident for you or bystanders, read this Operator's Guide before you operate the vehicle.

Also, read all safety labels on your vehicle and watch the *Safety Video* located at:

<https://can-am.brp.com/off-road/safety>

Or use the following QR code.



This vehicle is for off-road use only. It is mainly for general recreational use but it may also be used for utility purposes.

Failure to follow the warnings contained in this Operator's Guide can result in SERIOUS INJURY or DEATH.

### Age Recommendation

These vehicles are a category Y (Youth model), always follow these age recommendations:

- The Renegade 70 vehicle is a category Y-6+ and should be used by children age 6 or older under adult supervision, or operator age 16 or older.
- The Renegade 110 and Renegade 110 Xxc vehicles are a category Y-10+ and should be used by children age 10 or older under adult supervision, or operator age 16 or older.
- Also, never allow continued use of an ATV by a child if the child does not have the abilities to operate it safely, regardless of age.

## Training Course

Never operate this vehicle without proper instruction. **Take a training course.** All operators should receive training from a certified instructor.

For more information about ATV safety, contact an authorized Can--Am Off-road dealer to find out about available training courses nearest you.

In the United States, call the Specialty Vehicle Institute of America (SVIA) at 1 800 887-2887 or in Canada, the Canada Safety Council (CSC) at 1 613 739-1535.

## Safety Messages

The types of safety messages, what they look like and how they are used in this guide are explained as follows:

The safety alert symbol  indicates a potential injury hazard.

### WARNING

Indicates a potential hazard which, if not avoided, could result in serious injury or death.

### CAUTION

Indicates a hazardous situation which, if not avoided, could result in minor or moderate injury.

### NOTICE

Indicates an instruction which, if not followed, could result in severely damaged vehicle components or other property.

## Notice to Parents

Review this Operator's Guide with any user of the vehicle.

Please take time with the children to review the instructions on its safe and proper use, and pay particular attention to the on-product safety labels, before allowing them to ride the vehicle.

Understand the controls and operation of the vehicle and carefully read the Operator's Guide.

Always remember that your approach to safety influences the child.

 **WARNING**

**This ATV is not a toy.**

- **Children differ in skills, physical abilities, and judgement. Some children may not be able to operate an ATV safely.**
- **No one under age 16 should operate an ATV without adult supervision at all times.**
- **Never allow continued use of the vehicle by a child if he does not have the abilities, the strength or the judgement to operate it safely.**

## About this Operator's Guide

This Operator's Guide has been prepared to acquaint the owner/operator of a new vehicle with the various vehicle controls, maintenance and safe operating instructions. It is indispensable for the proper use of the product.

Keep this Operator's Guide in the vehicle as you can refer to it for things such as maintenance, troubleshooting and instructing others.

Note that this guide is available in several languages. In the event of any discrepancy, the English version shall prevail.

If you want to view and/or print an extra copy of your Operator's Guide, simply visit the following website:

**[www.operatorsguides.brp.com](http://www.operatorsguides.brp.com)**

The information contained in this document is correct at the time of publication. BRP, however, maintains a policy of continuous improvement of its products without imposing upon itself any obligation to install them on products previously manufactured. Due to late changes, some differences between the manufactured product and the descriptions and/or specifications in this guide may occur. BRP reserves the right at any time to discontinue or change specifications, designs, features, models or equipment without incurring any obligation upon itself.

This Operator's Guide should remain with the vehicle when it is sold.

While reading this Operator's Guide, remember that:



**WARNING**

Indicates a potential hazard which, if not avoided, could result in serious injury or death.

This page is intentionally blank

# **SAFETY INFORMATION**

---

## GENERAL PRECAUTIONS

### Avoid Carbon Monoxide Poisoning

All engine exhaust contains carbon monoxide, a deadly gas. Breathing carbon monoxide can cause headaches, dizziness, drowsiness, nausea, confusion and eventually death.

Carbon monoxide is a colorless, odorless, tasteless gas that may be present even if you do not see or smell any engine exhaust. Deadly levels of carbon monoxide can collect rapidly, and you can quickly be overcome and unable to save yourself. Also, deadly levels of carbon monoxide can linger for hours or days in enclosed or poorly ventilated areas. If you experience any symptoms of carbon monoxide poisoning, leave the area immediately, get fresh air and seek medical treatment.

To prevent serious injury or death from carbon monoxide:

- Never run the vehicle in poorly ventilated or partially enclosed areas such as garages, carports or barns. Even if you try to ventilate engine exhaust with fans or open windows and doors, carbon monoxide can rapidly reach dangerous levels.
- Never run the vehicle outdoors where engine exhaust can be drawn into a building through openings such as windows and doors.

### Avoid Gasoline Fires and Other Hazards

Gasoline is extremely flammable and highly explosive. Fuel vapors can spread and be ignited by a spark or flame many feet away from the engine. To reduce the risk of fire or explosion, follow these instructions:

- Use only an approved red gasoline container to store fuel.
- Never fill a gasoline container on the vehicle. An electrical static discharge may ignite the fuel.
- For refueling, strictly adhere to instructions in *Fuel*.
- Never start or operate the engine if the fuel cap is not properly installed.

Gasoline is poisonous and can cause injury or death.

- Never siphon gasoline by mouth.
- If you swallow gasoline, get any in your eye(s), or inhale gasoline vapor, see your doctor immediately.

If gasoline spills on you, wash with soap and water and change your clothes.

### Avoid Burns from Hot Parts

Certain components like brake rotors and exhaust components become hot during operation. Avoid contact with those parts during and shortly after operation to avoid burn wounds.



## Accessories and Modifications

Any modifications or addition of accessories approved by BRP may affect the handling of your vehicle. It is important to take the time to get familiar with the vehicle once modifications are made to understand how to adapt your driving behavior accordingly.

Avoid installing equipment not specifically approved by BRP for the vehicle and avoid unauthorized modifications. These modifications and equipment have not been tested by BRP and may create hazards. For example, they could:

- Create a loss of control and increase risk of crash
- Cause overheating or short circuits increasing the risk of fire or burn injuries
- Affect the protection features provided by the vehicle.
- Affect the behavior of the trailer when the vehicle is transported
- Cause a risk of losing objects on the road when transported.

Your vehicle may also become illegal to ride.

**Ask your authorized BRP dealer for suitable available accessories for your vehicle.**

---

## SPECIAL SAFETY MESSAGES

### THIS VEHICLE IS NOT A TOY AND CAN BE HAZARDOUS TO OPERATE.

- This vehicle handles differently from other vehicles. A collision or rollover can occur quickly if you fail to take proper precautions, even during routine maneuvers such as turning and driving on hills or over obstacles.

**SEVERE INJURY OR DEATH** can result if you do not follow these instructions:

- Read this Operator's Guide and all on-product safety labels carefully and follow the operating procedures described. Watch and pay attention to the safety video before operating the vehicle.
- Always follow this age recommendation: Renegade 70 vehicle should be used by children age 6 or older under adult supervision, or by an operator age 16 or older.
- Always follow this age recommendation: Renegade 110 and Renegade 110 Xxc vehicles should be used by children age 10 or older under adult supervision, or by an operator age 16 or older.
- Also, never allow continued use of an ATV by a child if he does not have the abilities to operate it safely, regardless of age.
- Never carry a passenger on this vehicle. Passenger(s) affect balance and steering and increase risk of losing control.
- Never operate this vehicle on any paved surfaces, including sidewalks, driveways, parking lots and streets.
- Never operate this vehicle on any public street, road or highway, even a dirt or gravel one.
- Never take place on this vehicle without wearing an approved helmet that fits properly. You should also wear eye protection (goggles or visor), gloves, boots, long sleeved shirt or jacket, and long pants.
- Never use this vehicle if you are tired, ill, or with drugs or alcohol. Your reaction time and judgement is greatly affected under these conditions.
- Never operate at excessive speeds. Always go at a speed that is proper for the terrain, visibility, and operating conditions, and your experience.
- Never attempt wheelies, jumps, or other stunts.
- Always inspect your vehicle prior to each time you use it to make sure it is in a safe operating condition. Always follow the inspection and maintenance procedures and schedules described in this Operator's Guide.
- Always keep both hands on the handlebars and both feet on the footpegs of the vehicle during operation.
- Always go slowly and be extra careful when operating on unfamiliar terrain. Always be alert to changing terrain conditions when operating this vehicle.
- Never operate on excessively rough, slippery, or loose terrain until you have learned and practiced the skills necessary to control this vehicle on such terrain. Always be especially cautious on these kinds of terrain.

- Always follow proper procedures for turning as described further in this Operator's Guide. Practice turning at low speeds before attempting to turn at faster speeds. Do not turn at excessive speed.
- Never operate this vehicle on hills too steep for the vehicle or for your abilities. Practice on smaller hills before attempting larger hills.
- Always follow proper procedures for climbing hills as described further in this Operator's Guide. Check the terrain carefully before you start up any hill. Never climb hills with excessively slippery or loose surfaces. Shift your weight forward. Never open the throttle suddenly or make sudden gear changes. Never go over the top of any hill at high speed.
- Always follow proper procedures for going down hills and for braking on hills as described further in this Operator's Guide. Check the terrain carefully before you start down any hill. Shift your weight backward. Never go down a hill at high speed. Avoid going down a hill at an angle that would cause the vehicle to lean sharply to one side. Go straight down the hill where possible.
- Always follow proper procedures for crossing the side of a hill as described further in this Operator's Guide. Avoid hills with excessively slippery or loose surfaces. Shift your weight to the uphill side of the vehicle. Never attempt to turn the vehicle around on any hill until you have mastered the turning technique described in this Operator's Guide on level ground. Avoid crossing the side of a steep hill if possible.
- Always use proper procedures if you stall or roll backwards when climbing a hill. To avoid stalling, use proper gear and maintain a steady speed when climbing a hill. If you stall or roll backwards, follow the special procedure for braking described in this Operator's Guide. Dismount on the uphill side or to a side if pointed straight uphill. Turn the vehicle around and remount, following the procedure described further in this Operator's Guide.
- Always check for obstacles before operating in a new area. Never attempt to operate over large obstacles, such as large rocks or fallen trees. Always follow proper procedures when operating over obstacles as described further in this Operator's Guide.
- Always be careful when skidding or sliding. Learn to safely control skidding or sliding by practicing at low speeds and on level smooth terrain. On extremely slippery surfaces, such as ice, go slowly and be very cautious in order to reduce the chance of skidding out of control.
- Never operate this vehicle in fast flowing water or in water deeper than that specified in this Operator's Guide. Remember that wet brakes may have reduced stopping ability. Test your brakes after leaving water, mud or snow. If necessary, apply them several times to let friction dry out the pads.
- Always keep in mind that braking distance is readily affected by but not limited to; weather and terrain conditions, braking system and

- tire conditions, vehicle speed and attitude. Remember to adjust your driving accordingly.
- BRP recommends sitting on your ATV when operating in reverse. Avoid standing up. Your weight could shift forward against the throttle lever causing an unexpected acceleration and loss of control.
  - Always use the size and type tires specified further in this Operator's Guide. Always maintain proper tire pressure as described further in this Operator's Guide.
  - Never load a youth model vehicle.
  - Never operate this vehicle without proper instruction. **Take a training course.** All operators should receive training from a certified instructor.

## OPERATION WARNINGS

### Operating Vehicle Without Proper Instruction

 **WARNING**



#### **POTENTIAL HAZARD**

Operating this vehicle without proper instruction.

#### **WHAT CAN HAPPEN**

The risk of an accident is greatly increased if the operator does not know how to operate this vehicle properly in different situations and on different types of terrain.

#### **HOW TO AVOID THE HAZARD**

Beginners and inexperienced operators should complete a training course. They should then regularly practice the skills learned during the course as well as the operating techniques described in this Operator's Guide.

For more information about a training course, contact an authorized Can-Am dealer.

## Age Recommendations

 **WARNING**

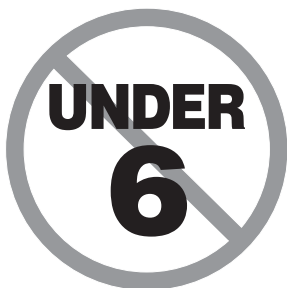

### **POTENTIAL HAZARD**

Failure to follow the age recommendations for this vehicle.

### **WHAT CAN HAPPEN**

Use by children of ATVs that are not recommended for their age can lead to severe injury or death of the child.

Even though a child may be within the age group for which this vehicle is recommended, he may not have the skills, abilities, or judgment needed to operate this vehicle safely and may be involved in a serious accident.

### **HOW TO AVOID THE HAZARD**

Renegade 70 vehicle should be used by children age 6 or older under adult supervision, or by an operator age 16 or older.

Renegade 110 and Renegade 110 Xxc vehicles should be used by children age 10 or older under adult supervision, or by an operator age 16 or older.

Also, never allow continued use of an ATV by a child if he does not have the abilities to operate it safely, regardless of age.

## Carrying a Passenger

 **WARNING**



V00A020

### **POTENTIAL HAZARD**

**Carrying a passenger on this vehicle.**

### **WHAT CAN HAPPEN**

**Greatly reduces your ability to balance and control this vehicle. Could cause an accident, resulting in harm to you and/or your passenger.**

### **HOW TO AVOID THE HAZARD**

**Never carry passenger. Even with a long seat that provides unrestricted operator movement, it is not designed nor intended to carry passenger(s).**

## Vehicle on Public Streets, Roads or Highways

 **WARNING**



### **POTENTIAL HAZARD**

Operating this vehicle on public streets, roads or highways.

### **WHAT CAN HAPPEN**

You can collide with another vehicle.

### **HOW TO AVOID THE HAZARD**

Never operate this vehicle on any public street, road or highway, even a dirt or gravel one. In many states it is illegal to operate this vehicle on public streets, roads and highways.



**⚠ WARNING****POTENTIAL HAZARD**

Operating this vehicle on public streets, roads or highways.

**WHAT CAN HAPPEN**

You can collide with another vehicle.

**HOW TO AVOID THE HAZARD**

Never operate this vehicle on any public street, road or highway, even a dirt or gravel one. In many states it is illegal to operate this vehicle on public streets, roads and highways.

## Riding Without Protective Gear

 **WARNING**



### POTENTIAL HAZARD

Riding this vehicle without wearing an approved helmet, eye protection and protective gear.

### WHAT CAN HAPPEN

- Riding without an approved helmet increases the chances of a severe head injury or death in the event of an accident.
- Riding without eye protection can result in an accident and increases the chances of a severe injury in the event of an accident.
- Riding without protective gear increases the chances of severe injury in the event of an accident.

### HOW TO AVOID THE HAZARD

Always wear an approved helmet that fits properly. You should also wear:

- Eye protection (goggles or face shield)
- Rigid chin guard
- Gloves and boots
- Long sleeved shirt or jacket
- Long pants.

## Drugs or Alcohol

 **WARNING**



V00A07Q

### **POTENTIAL HAZARD**

**Using this vehicle with drugs or alcohol.**

### **WHAT CAN HAPPEN**

**Could seriously affect your judgment.**

**Could cause you to react more slowly.**

**Could affect your balance and perception.**

**Could result in an accident or death.**

### **HOW TO AVOID THE HAZARD**

**Never use this vehicle with drugs or alcohol.**

## Excessive Speeds

 **WARNING**

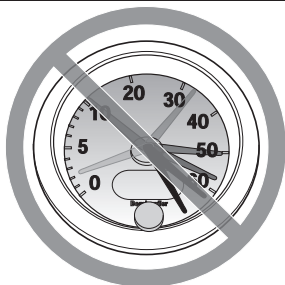

V00A08Q

### **POTENTIAL HAZARD**

Operating this vehicle at excessive speeds.

### **WHAT CAN HAPPEN**

Increases your chances of losing control of the vehicle, which can result in an accident.

### **HOW TO AVOID THE HAZARD**

Always travel at a speed which is appropriate for the terrain, visibility and operating conditions, and your experience.

## Wheelies, Jumps and Other Stunts

**! WARNING**



**POTENTIAL HAZARD**

Attempting wheelies, jumps and other stunts.

**WHAT CAN HAPPEN**

Increases the chance of an accident, including an overturn.

**HOW TO AVOID THE HAZARD**

Never attempt stunts, such as wheelies or jumps. Do not try to show off.

**! WARNING**



**POTENTIAL HAZARD**

Attempting wheelies, jumps and other stunts.

**WHAT CAN HAPPEN**

Increases the chance of an accident, including an overturn.

**HOW TO AVOID THE HAZARD**

Never attempt stunts, such as wheelies or jumps. Do not try to show off.

## Vehicle Inspection

 **WARNING**

**POTENTIAL HAZARD**

Failure to inspect the vehicle before operating.  
Failure to properly maintain the vehicle.

**WHAT CAN HAPPEN**

Increases the possibility of an accident or equipment damage.

**HOW TO AVOID THE HAZARD**

Always inspect your vehicle prior to ride to make sure the vehicle is in safe operating condition.

Always follow the maintenance schedule described in this Operator's Guide.

## Frozen Waterways

 **WARNING**

**POTENTIAL HAZARD**

Riding on frozen waterways.

**WHAT CAN HAPPEN**

Breaking through the ice can lead to severe injury or death.

**HOW TO AVOID THE HAZARD**

Never ride this vehicle on a frozen surface before you are sure the ice is thick enough and sound enough to support the vehicle and its load, as well as the force that is created by a moving vehicle.

## Proper Position on the Vehicle

 **WARNING**



### **POTENTIAL HAZARD**

Removing hands from handlebars or feet from the footrests during operation.

### **WHAT CAN HAPPEN**

Removing even one hand or foot can reduce your ability to control the vehicle or could cause you to lose your balance and fall off the vehicle. If you remove a foot from the footrests, your foot or leg may come into contact with the rear wheels, which could injure you or cause an accident.

### **HOW TO AVOID THE HAZARD**

Operator must always keep both hands on the handlebars and both feet on the footrests during vehicle operation.

## Unfamiliar Terrain

 **WARNING**



### **POTENTIAL HAZARD**

Failure to use extra care when operating this vehicle on unfamiliar terrain.

### **WHAT CAN HAPPEN**

You can come upon hidden rocks, bumps, or holes, without enough time to react.

Could result in the vehicle overturning or loss of control.

### **HOW TO AVOID THE HAZARD**

Go slowly and be extra careful when operating on unfamiliar terrain.

Always be alert to changing terrain conditions when operating the vehicle.



## Operating on Excessively Rough, Slippery or Loose Terrain

### WARNING



#### **POTENTIAL HAZARD**

Failure to use extra care when operating on excessively rough, slippery or loose terrain.

#### **WHAT CAN HAPPEN**

Could cause loss of traction or vehicle control, which could result in an accident, including an overturn.

#### **HOW TO AVOID THE HAZARD**

Do not operate on excessively rough, slippery or loose terrain until you have learned and practiced the skills necessary to control this vehicle on such terrain.

Always be especially cautious on these kinds of terrain.

## Turning Improperly

 **WARNING**



### **POTENTIAL HAZARD**

Turning improperly.

### **WHAT CAN HAPPEN**

Vehicle could go out of control, causing a collision or an overturn.

### **HOW TO AVOID THE HAZARD**

Always follow proper procedures for turning as described in this Operator's Guide. Practice turning at low speeds before attempting to turn at faster speeds.

Do not turn at excessive speed.

## Excessively Steep Hills

 **WARNING**



### **POTENTIAL HAZARD**

Operating on excessively steep hills.

### **WHAT CAN HAPPEN**

The vehicle can overturn more easily on extremely steep hills than on level surfaces or small hills.

### **HOW TO AVOID THE HAZARD**

Never operate this vehicle on hills too steep for the vehicle or for your abilities.

Practice on smaller hills before attempting larger hills.

## Climbing Hills

 **WARNING**



### **POTENTIAL HAZARD**

Climbing hills improperly.

### **WHAT CAN HAPPEN**

Could cause loss of control or cause vehicle to overturn.

### **HOW TO AVOID THE HAZARD**

Always follow proper procedures for climbing hills as described in this Operator's Guide.

Always check the terrain carefully before you start up any hill.

Never climb hills with excessively slippery or loose surfaces.

Shift your weight forward.

Never open the throttle suddenly or make sudden gear changes. The vehicle could flip over backwards.

Never go over the top of any hill at high speed. An obstacle, a sharp drop, or another vehicle or person could be on the other side of the hill.

## Down a Hill

### WARNING



#### **POTENTIAL HAZARD**

Going down a hill improperly.

#### **WHAT CAN HAPPEN**

Could cause loss of control or cause vehicle to overturn.

#### **HOW TO AVOID THE HAZARD**

Always follow proper procedures for going down hills as described in this Operator's Guide.

#### **NOTE:**

A special technique is required when braking as you go down a hill.

Always check the terrain carefully before you start down any hill.

Shift your weight backward.

Never go down a hill at high speed.

Avoid going down a hill at an angle which would cause the vehicle to lean sharply to one side. Go straight down the hill where possible.

## Crossing or Turning on Hills

**! WARNING**



**POTENTIAL HAZARD**

Improperly crossing hills or turning on hills.

**WHAT CAN HAPPEN**

Could cause loss of control or cause vehicle to overturn.

**HOW TO AVOID THE HAZARD**

Never attempt to turn the vehicle around on any hill until you have mastered the turning technique as described in this Operator's Guide on level ground. Be very careful when turning on any hill.

Avoid crossing the side of a steep hill if possible.

When crossing the side of a hill:

Always follow proper procedures as described further in this Operator's Guide.

Avoid hills with excessively slippery or loose surfaces.

Operator must shift weight to the uphill side of the vehicle.

## Stalling, Rolling Backwards or Dismounting While Climbing a Hill

### WARNING

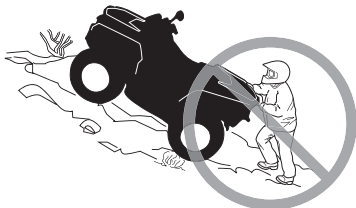

#### POTENTIAL HAZARD

Stalling, rolling backwards or improperly dismounting while climbing a hill.

#### WHAT CAN HAPPEN

Could result in vehicle overturning.

#### HOW TO AVOID THE HAZARD

Use low gear and maintain steady speed when climbing a hill.

If you lose all forward speed:

Operator must keep their weight uphill. Never open the throttle suddenly or make sudden gear changes. The vehicle could flip over backwards.

Apply the brakes.

Lock parking brake after you have stopped.

Disembark on uphill side, or to a side if pointed straight uphill.

If you begin rolling backwards:

Operator must keep their weight uphill. Never open the throttle suddenly or make sudden gear changes. The vehicle could flip over backwards.

Never apply the rear brake while rolling backwards.

Apply the front brake gradually.

When fully stopped, apply rear brake as well and lock parking brake.

Disembark on uphill side, or to a side if pointed straight uphill.

Turn the vehicle around and remount, following the procedure described further in this Operator's Guide.

## Operating Over Obstacles

 **WARNING**



### **POTENTIAL HAZARD**

Improperly operating over obstacles.

### **WHAT CAN HAPPEN**

Could cause loss of control or a collision.

Could cause the vehicle to overturn.

### **HOW TO AVOID THE HAZARD**

Before operating in a new area, check for obstacles.

Never attempt to ride over large obstacles, such as large rocks or fallen trees.

When you go over obstacles, always follow proper procedures as described in this Operator's Guide.



## Skidding or Sliding

### WARNING



#### **POTENTIAL HAZARD**

Skidding or sliding improperly.

#### **WHAT CAN HAPPEN**

You may lose control of this vehicle.

You may also regain traction unexpectedly, which may cause the vehicle to overturn.

#### **HOW TO AVOID THE HAZARD**

Learn to safely control skidding or sliding by practicing at low speeds and on level smooth terrain.

On extremely slippery surfaces, such as ice, go slowly and be very cautious in order to reduce the chance of skidding or sliding out of control.

## Deep or Fast Flowing Water

**! WARNING**



### **POTENTIAL HAZARD**

Operating this vehicle through deep or fast flowing water.

### **WHAT CAN HAPPEN**

Tires may float, causing loss of traction and loss of control, which could lead to an accident.

### **HOW TO AVOID THE HAZARD**

Never operate this vehicle in fast flowing water or in deep water.

Check water depth and current before you attempt to cross any water. Water should not go above the center of the wheels.

Remember that wet brakes may have reduced stopping ability.

Test your brakes after leaving water. If necessary, apply them several times to let friction dry out the pads.

**! WARNING****POTENTIAL HAZARD**

Operating this vehicle through deep or fast flowing water.

**WHAT CAN HAPPEN**

Tires may float, causing loss of traction and loss of control, which could lead to an accident.

**HOW TO AVOID THE HAZARD**

Never operate this vehicle in fast flowing water or in deep water.

Check water depth and current before you attempt to cross any water. Water should not go above the top of the wheels.

Remember that wet brakes may have reduced stopping ability.

Test your brakes after leaving water. If necessary, apply them several times to let friction dry out the pads.

## Operating in Reverse

**! WARNING**



**POTENTIAL HAZARD**

Improperly operating in reverse.

**WHAT CAN HAPPEN**

You could hit an obstacle or person behind the vehicle, resulting in serious injury.

**HOW TO AVOID THE HAZARD**

When you select reverse gear, make sure there are no obstacles or people behind the vehicle. When it is safe to proceed, go slowly.

## Tire Pressure

 **WARNING**



### **POTENTIAL HAZARD**

Operating this vehicle with improper tires, or with improper or uneven tire pressure.

### **WHAT CAN HAPPEN**

Use of improper tires on this vehicle, or operation of this vehicle with improper or uneven tire pressure, may cause loss of control, tire blow outs, tire to move around on its rim, and increases the risk of an accident.

### **HOW TO AVOID THE HAZARD**

Always use the size and type of tires specified in this Operator's Guide for this vehicle.

Always maintain proper tire pressure as described in this Operator's Guide.

Always replace wheels or tires that are damaged.

 **WARNING**



**POTENTIAL HAZARD**

Operating this vehicle with improper tires, or with improper or uneven tire pressure.

**WHAT CAN HAPPEN**

Use of improper tires on this vehicle, or operation of this vehicle with improper or uneven tire pressure, may cause loss of control, tire blow outs, tire to move around on its rim, and increases the risk of an accident.

**HOW TO AVOID THE HAZARD**

Always use the size and type of tires specified in this Operator's Guide for this vehicle.

Always maintain proper tire pressure as described in this Operator's Guide.

Always replace wheels or tires that are damaged.

## Improper Modifications

 **WARNING**



### **POTENTIAL HAZARD**

Operating this vehicle with improper modifications.

### **WHAT CAN HAPPEN**

Improper installation of accessories or modification of this vehicle may cause changes in handling which in some situations could lead to an accident.

### **HOW TO AVOID THE HAZARD**

Never modify this vehicle through improper installation or use of accessories. All parts and accessories added to this vehicle should be approved by BRP and should be installed and used according to instructions. If you have questions, consult an authorized Can-Am Off-road dealer.

**NEVER** install a passenger seat or use the racks to carry a passenger.

Modification of the vehicle to increase speed and performance may violate the terms and conditions of your vehicle limited warranty. In addition, certain modifications including the removal of engine or exhaust components are illegal under most laws.

## Loading, Carrying or Towing Cargo

 **WARNING**



**POTENTIAL HAZARD**

Overloading this vehicle, carrying or towing cargo improperly.

**WHAT CAN HAPPEN**

Could cause changes in vehicle handling which could lead to an accident.

**HOW TO AVOID THE HAZARD**

Never load cargo on this vehicle.

Never tow cargo or another vehicle with this vehicle.



## Transporting Flammable or Dangerous Material

 **WARNING**



V03M01Q

### **POTENTIAL HAZARD**

Transporting flammable or dangerous material can lead to explosions.

### **WHAT CAN HAPPEN**

This can cause serious injury or death.

### **HOW TO AVOID THE HAZARD**

Never transport flammable or dangerous material.

 **WARNING**



V03M01Q

**POTENTIAL HAZARD**

Transporting flammable or dangerous material can lead to explosions.

**WHAT CAN HAPPEN**

This can cause serious injury or death.

**HOW TO AVOID THE HAZARD**

Never transport flammable or dangerous material.

Always use a BRP LinQ fuel container to transport fuel on vehicle. Only the approved BRP LinQ fuel container can be attached securely in the front storage compartment of the vehicle.

 **WARNING**

V03M010

**POTENTIAL HAZARD**

Transporting flammable or dangerous material can lead to explosions.

**WHAT CAN HAPPEN**

This can cause serious injury or death.

**HOW TO AVOID THE HAZARD**

Never transport flammable or dangerous material.

This vehicle is not designed to receive securely no fuel containers available in the market.

# PRE-RIDE INSPECTION

## WARNING

Perform a pre-ride inspection before each ride to detect any potential problem that could occur during operation. The pre-ride inspection can help you monitor wear and deterioration before they become a problem. Correct any problem that you discover to reduce the risk of a breakdown or crash.

Before using this vehicle, the operator and/or an adult should always perform the following pre-ride inspection check list.

## Pre-Ride Inspection Check List

### *What to Do Before Starting the Engine (Key OFF)*

Items To Be Inspected	Inspection to Perform	✓
Fluids	Check the fuel level and the engine oil level.	
Leaks	Check for any leaks under the vehicle.	
Steering	Check that the steering operates freely by turning it completely from side to side.	
Throttle lever	Activate the throttle lever several times to ensure that it operates freely. It must return to the idle position when released.	
	Ensure that the speed limiter screw is properly adjusted according to the rider's ability.	
Brakes	Squeeze the brake levers several times to ensure that they operate freely. They must immediately return to their original positions when released.	
Parking brake	Apply the parking brake and ensure that it operates properly.	
Tires	Check the tire pressure and the tire condition.	
Wheels	Check the wheels for damage or abnormal play, and that the bolts are tight.	

Items To Be Inspected	Inspection to Perform	✓
Drive chain and sprockets	Inspect the sprockets for wear or damage.	
	Check the drive chain, slider, and drive chain tensioner for proper adjustment and lubrication (as applicable).	
Seat	Ensure operator's seat is properly locked in position by pulling back and up several time. Even if a distinctive snap is heard during the installation, always pull it back and up to confirm proper latching.	
Exhaust	If not already done, clean the area surrounding the exhaust system, especially if during the last ride, the vehicle was used in a swamp, bog, hay or dead leaves.	
Chassis and suspension	Check underneath the vehicle for any debris on the chassis or suspension. If necessary, clean the chassis and suspension.	

### ***What to Do Before Starting the Engine (Key ON)***

Items To Be Inspected	Inspection to Perform	✓
Indicator lamps	Check the operation of the check engine indicator lamp (during the first few seconds of key ON).	
	Ensure that the N (neutral) and R (reverse) indicator lamps come ON according to the transmission lever selection.	
Lights	Check the operation and cleanliness of the daytime running lights and taillight.	
	Check the operation of the brake light.	

**What to Do After the Engine is Started**

<b>Items To Be Inspected</b>	<b>Inspection to Perform</b>	✓
Indicator lamps	Ensure that the check engine indicator lamp is off (if the light stays on, shut the engine off).	
Transmission lever	Check the operation of the transmission lever (F, N, and R).	
Brakes	Slowly drive forward over a very short distance. Apply both brake levers individually. The brakes must fully apply. The levers must return to their rest positions when released.	
Emergency engine stop switch	Check that the emergency engine stop switch is working properly.	
Ignition switch	Check that the ignition switch is working properly by stopping and restarting the engine.	

---

## RIDING THE VEHICLE

To fully appreciate the pleasures and excitement of riding this vehicle, there are some basic rules and tips that you **MUST** follow. Some may be new to you while others may be common sense or obvious.

Please take the time to study this Operator's Guide and all on-product safety labels as well as the safety video mentioned in *General Information*. They more completely describe what you should know about this vehicle before riding it.

For the child's safety, we strongly recommend you also follow and enforce this recommendation. You are the sole judge of a rider's capability to understand the risks and operate a vehicle safely.

Individuals with cognitive or physical impairments or who are high risk takers have an increased exposure to overturns or collisions which may result in injury including death.

Not all vehicles are the same. Each has its own unique performance characteristics, controls and features. Each will ride and handle differently.

Become completely familiar with the operational controls and the general operation of the vehicle before venturing into off road conditions. Practice driving in a suitable area free of hazards and feel the response of each control. Drive at low speeds. Higher speeds require greater experience, knowledge and suitable riding conditions.

Riding conditions vary from place to place. Each is subject to weather conditions which may radically change from time to time and from season to season.

Riding on sand is different than riding on snow or through forests or marshes. Each location may require a greater degree of awareness and skills. Show good judgement. Always proceed with caution. Please do not take any unnecessary risks that could leave you stranded or possibly injured.

Never assume that the vehicle will go everywhere safely. Sudden changes in terrain caused by holes, depressions, banks, softer or harder "ground" or other irregularities may cause the vehicle to topple or become unstable. To avoid this, slow down and always observe the terrain ahead. If the vehicle does begin to topple or tip over, the best advice is to immediately get off... **AWAY** from the direction of the tip over!

We encourage you to have an Annual Safety Inspection of your vehicle. Please contact an authorized Can-Am Off-road dealer for further details. Though not required, it is recommended that an authorized Can-Am Off-road dealer performs the preseason preparation of your vehicle. Each visit to your authorized Can-Am Off-road dealer is a great opportunity for your dealer to verify if your vehicle is included in any safety campaign. We also urge you to visit your authorized

Can-Am Off-road dealer in a timely manner if you become aware of any safety related campaigns.

See an authorized Can-Am Off-road dealer for available accessories you may require.

## **Riding Gear**

Actual weather conditions should help you decide how to dress. Dress for the coldest weather expected. Thermal underwear next to the skin also provides a good insulation. It is important that the operator always wears the appropriate protective riding gear and apparel, including an approved helmet, eye protection, boots, gloves, a long sleeved shirt and pants. This type of clothing will provide you protection from some of the minor hazards you may encounter en route. The operator must never wear loose clothing such as a scarf that may get entangled in the vehicle or on tree branches and shrubs. Depending on conditions, anti-fogging goggles or sunglasses may be required. Different colored lenses available for goggles or sunglasses help you distinguish terrain variations. Sunglasses should only be worn during the daytime.





## Carrying a Passenger is Prohibited

This vehicle is designed specifically to carry an operator only. Even with a long seat, this vehicle is not designed nor intended to carry passenger(s). NEVER install passenger seat or use the cargo area to carry passenger(s). Carrying passenger(s) may affect the stability and your control of the vehicle.

## Carrying Loads

Never load cargo on this vehicle.

## Recreational Riding

Respect the rights and limitations of others. Stay away from areas designated for other types of off road use. This includes snowmobile trails, equestrian trails, cross country ski trails, mountain bike trails, etc. Never assume there are no other users on the trail. Always stay to the complete right of the trail and do not zigzag to one side of the trail then the other. Be prepared to stop or pull off to the side if another trail user appears in front of you.

Join a local ATV club. It will provide you with a map and advice or inform you where you can ride. If a club does not exist in your area, help to start one. Group riding and club activities provide a pleasurable, social experience.

Always keep a safe distance from other riders. Your judgment of speed, terrain conditions, weather, mechanical condition of your vehicle and the "trust in judgment" you have in others around you will help you make a better choice of appropriate safe distance. This vehicle, like any other motorized vehicle, cannot stop "on a dime". Allow greater distance for braking.

Before you ride, tell someone where you are planning to travel and your expected time of return.

Depending on the length of your ride, carry additional tools, drinking water, food and emergency equipment. Find out where you can get additional gasoline and oil. Be prepared for the possible conditions you may encounter.

First aid kit	Adjustable wrench
Mobile phone	Knife
Friction tape	Flashlight
A rope	Colored lens goggles
Spare light bulbs	Trail map
Provided tool kit	Snack

## Environment

One of the benefits of this vehicle is that it can take you off the beaten path away from most communities. However, you should always respect nature and the rights of others to enjoy it. Do not ride in environmentally sensitive areas. Do not drive over forest crops or shrubs, nor cut down trees or take down fencing, nor spin your wheels and destroy the terrain. "Tread Lightly".

This vehicle can cause OHV wildfires if debris builds up near the exhaust or other engine hot spots and ignites then falls off into dry grass. Avoid riding in wet areas, through muskeg or tall grass, where debris can build up. Should you ride in those areas, inspect and remove all debris from your engine and hot spots. Refer to *Vehicle Care* for details.

Chasing wildlife is in many areas illegal. Wildlife can die of exhaustion after being chased by a motorized vehicle. If you encounter animals on the trail, stop and observe quietly and with caution. It will be one of the better memories of your life.

Observe the rule "what you take in, carry out". Do not litter. Do not start campfires unless you have permission to do so, and then only away from dry areas. The hazards you may create on the trail may cause injury to others or yourself, even at a later date.

Respect farm lands. Always obtain the permission of the landowner before riding on private land. Respect crops, farm animals and property lines.

Finally, do not pollute streams, lakes or rivers and do not modify the engine or exhaust system, or remove any of its components as it will alter the vehicle emissions.

## Design Limitation

Although the vehicle is exceptionally rugged for its class, it is still a light vehicle by definition and its operation must be restricted to its proper purpose.

The addition of weight to any part of the vehicle changes its gravitational stability and modifies its performance.

## Off-Road Operation

The very nature of off-road operation is dangerous. Any terrain, which has not been specially prepared to carry vehicles, presents an inherent danger where terrain substance, shape and steepness are unpredictable. The terrain itself presents a continual element of danger, which must be knowingly accepted by anyone venturing over it.

An operator who takes a vehicle off-road should always exercise the utmost care in selecting the safest path and keeping close watch on the terrain ahead of him. The vehicle should never be operated by anyone who is not completely familiar with the driving instructions applicable to the vehicle, nor should it be operated on steep or treacherous terrain.

## **Riding Techniques**

Information in this guide is limited. Increase your knowledge and improve your skills by following a certified training course.

Care, caution, experience and driving skill are the best precautions against the hazards of vehicle operation.

Respect and follow all posted trail signs. They are there to help you and others.

In off-road operation, power and traction, not speed, are important. Never drive faster than visibility and your own ability to select a safe route permits.

Constantly watch the terrain ahead for sudden changes in slopes or obstacles, such as rocks or stumps, that may cause loss of stability, resulting in tip over or rollover.

It is also wise to know the terrain condition on the other side of a hill or bank. All too often there exists a sharp drop-off that is impossible to negotiate or descend.

Whenever there is the slightest doubt that the vehicle can safely negotiate an obstacle or a particular piece of terrain, always choose an alternate route.

Always use proper riding techniques to avoid vehicle overturns on hills and rough terrain and in turns.

### ***Body Position***

To maintain proper control, it is strongly advised that you keep your hands on the handlebar and within easy reach of all controls. The same holds true for your feet on the foot pegs. To minimize the possibility of a leg or foot injury, keep your feet on the foot pegs at all times. Do not direct your toes outwards nor extend your feet out to assist in turning as they can be hit or be snagged on passing obstacles, or may come into contact with the wheels.

Even though there is a suspension on this vehicle, there are "washboard" or rough terrain conditions that will make you feel uncomfortable and can even cause a back injury. "Posting" or riding in a crouched position will often be required. Slow down and allow your flexed legs to absorb part of the impact energy.

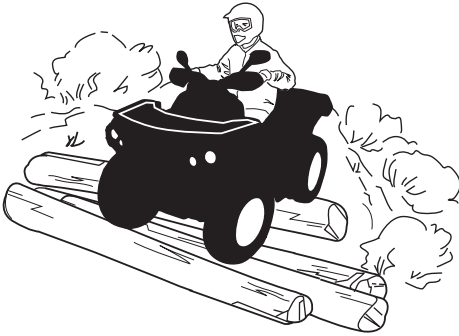

### ***Crossing Roads***

If you have to cross a road, ensure to have complete visibility on both sides for incoming traffic and decide on exit point on other side of road. Drive in a straight line toward that point. Do not make sharp direction changes or abrupt accelerations as it may result in a rollover situation. Do not travel on sidewalks or bicycle trails as they are designated specifically for those uses.

### ***Turning***

Practice turning at low speeds before attempting to turn at faster speeds.

Keep both hands on handlebars and feet on footpegs.

Maintain a constant speed or a slight acceleration during turn.

To reduce the risk of rollovers:

- Use care when turning.
  - Do not turn the handlebar too far or too fast for your speed and environment. Adjust steering inputs accordingly.
  - Slow down before entering a turn. Avoid hard braking during a turn.
  - Avoid sudden or hard acceleration when turning, even from a stop or low speed.
- Never attempt donuts, skids, slides, fishtails, jumps, or other stunts. If vehicle starts to skid or slide, steer in the direction of the skid or slide. Never slam the brakes and lock the wheels.
- Avoid paved surfaces. This vehicle is not designed to operate on paved surfaces and is more likely to roll over. If you must drive on pavement, turn gradually, go slowly, and avoid abrupt acceleration and braking.

Avoid sudden inputs to steering, throttle or brakes while turning.

**⚠ WARNING**

**Do not attempt turns at excessive speed.**

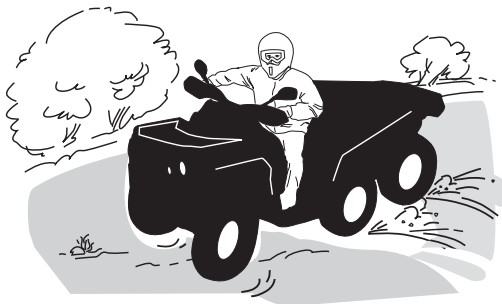
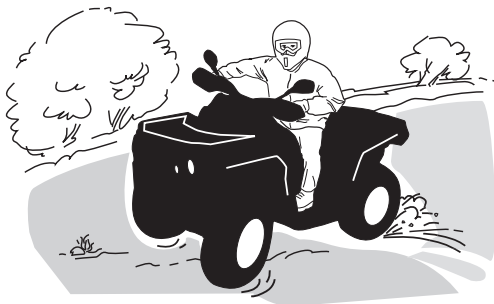

If you do get into a slide or skid, it may help to turn the handlebar in the direction of the skid until you regain control. Never jam the brakes and lock the wheels.

**⚠ WARNING**

**The tires of this vehicle are not suited for paved road use. Also this vehicle is not equipped with a rear differential (rear wheels are always turning at the same speed). For these reasons, pavement may seriously affect the handling and control of the vehicle.**

## **Braking**

Always keep both hands on handlebars and feet on footpegs when braking.

Practice braking to get familiar with the brake response.

- Do it at low speed first, then increase the speed.
- Practice braking in straight line at different speeds and different braking force.
- Practice emergency braking; optimal braking is obtained in straight line, with high force applied, without locking the wheels.

Remember, braking distance depends on vehicle speed, load and the type of surface. Also, the tires and brakes conditions play a major role.

### **NOTE:**

If going forward the vehicle weight is transferred to the front wheels when braking. To obtain greater stopping efficiency, the brake system distributes more braking force to the front wheels. This will affect vehicle handling and steering control when braking vigorously. Take it into account when braking.

**Brake lever:** Each time the brake lever is used, the front and rear brakes are activated, whether in 4x6 or 6x6 mode.

### **Brake pedal:**

- In 4x6 mode, the brake pedal activates ONLY the rear brakes.
- In 6x6 mode, the brake pedal activates ALL brakes (front and rear).

## **Reverse Operation**

When operating in reverse, check that the path behind the vehicle is free of people or obstacles. Proceed slowly and avoid sharp turns.

We recommend sitting on your ATV when operating in reverse. Avoid standing up. Your weight could shift forward against throttle lever, causing an unexpected acceleration.



### **WARNING**

**Unexpected acceleration when the ATV is operated in reverse can cause a loss of control.**

## **Obstacles**

Obstacles in the "trail" should be traversed with caution. This includes loose rocks, fallen trees, slippery surfaces, fences, posts, and embankments and depressions. You should avoid them whenever possible. Remember that some obstacles are too large or dangerous to

cross and should be avoided. Small rocks or fallen trees may be safely crossed approach at a 90° angle. Stand on the footrests while keeping your knees flexed. Adjust speed without losing momentum and do not “gun” the throttle. Hold handlebar firmly. Place body weight rearwards and proceed. Do not try to lift the vehicle front wheels off the ground. Be aware that the object may be slippery or may move while crossing.

### ***Uphill Driving***

Before trying to climb a hill, keep these things in mind. Hill Climbing should only be attempted by experienced operators. Start on shallow slopes. Always drive straight uphill and keep your body weight forward towards the top of the hill. Keep your feet on the footrests, shift your ATV into a lower gear and accelerate before you start to climb. Try to keep a steady speed and go easy on the throttle to avoid acceleration. Abrupt slope or terrain variation or rolling one wheel over an obstacle could have a big impact on the stability as it will lift the front of the vehicle increasing the risk of tipping over. Some hills are too steep to safely stop or recover from after an unsuccessful climbing attempt. Try to avoid steep inclines. If you're not careful, you could tip over when going up hills. If the hill is too steep and you cannot proceed or the vehicle begins to roll backwards, apply the brake, being careful not to slide, put the parking brake. Dismount on the left side then use the “K” turn (while walking back, next to the vehicle on the up hill side and with a hand on the brake lever, slowly back the rear of the vehicle toward the top of the hill then drive downhill). Always walk or dismount on the upside of the slope while keeping clear of the vehicle and its rotating wheels. Do not try to hold on to the vehicle if it begins to topple. Stay clear. Do not ride over the crest of the hill at high speed. Obstacles, including sharp drop-offs, may exist.



### **Vehicle Behaviors**

Due to configuration, this vehicle has excellent climbing ability, so much so that it is possible to tip over before traction is lost. For example, it is common to encounter terrain situations where the top of the hill has eroded to a point that the hill peak rises very sharply. The



vehicle can readily negotiate such a condition, however, in doing so, when the front of the vehicle is driven to a point that the vehicle's balance moves rearward, a tip over can occur.

The same situation may apply if an embedded object causes the front of the vehicle to climb more than desired. If such a situation occurs take an alternate route. Be aware of side hilling dangers when doing so. Refer to *SIDE HILLING* below.

### ***Downhill Driving***

Keep your body weight rearwards. Stay seated. Apply the brake gradually to prevent skidding. Do not "coast" down the slope using solely engine compression or in neutral gear.

Decelerating while negotiating a slippery downhill slope could "toboggan" the vehicle. Maintain steady speed and/or accelerate slightly to regain control. Try to avoid steep inclines. If you're not careful, you could tip over when going down hills.

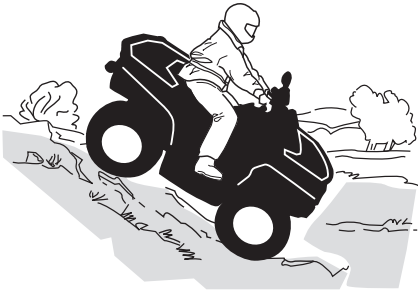

## **Vehicle Behaviors**

This vehicle can climb slopes that are steeper than it can safely descend. Therefore, it is essential to ensure that a safe route exists to descend a slope before you climb it.

### ***Side Hilling***

This is one of the **most risky** types of riding since it may drastically change the balance of the vehicle. It should be avoided whenever possible. However, if it is necessary to do so, it is important that you **ALWAYS** keep your body weight on the upside of the slope and be prepared to dismount on that side should the vehicle begin to topple.

Avoid all objects or depressions that will intensify the raising of one side of the vehicle higher than the other, thus causing rollover.

**! WARNING**

**Do not try to stop or save the vehicle from damage.**

**! WARNING**

**Be careful when loading and transporting liquid reservoirs. They can affect vehicle stability when side hilling by pulling downhill and increasing the risk of a rollover.**



***Drop-Offs***

This vehicle will “bottom out” and usually stop if either the front or rear wheels are driven over a drop-off. If the drop is sharp or deep, the vehicle will nose dive and tip over.

**! WARNING**

**Avoid negotiating drop-offs. Reverse and select an alternate route.**

***Crossing Water***

Water can be a unique hazard. If it is too deep the vehicle may “float” and topple. Check the water depth and current before you attempt to cross any water.

Water should not go above the footrest.

Water should not go above the tires.

Be wary of slippery surfaces such as rocks, grass and logs, both in the water and on its banks. A loss of traction may occur. Do not attempt to enter the water at high speed. The water will act as a brake and could throw you off the vehicle, on the ground.



Wet brakes will affect the braking ability of your vehicle. Make sure you dry the brakes by applying them several times after the vehicle leaves the water, mud or snow. Allow greater distance for braking.

Mud or marsh lands may be encountered near water. Be prepared for sudden “holes” or changes in depth. Similarly, be watchful of hazards such as rocks and logs that are partially covered by vegetation.

### ***Riding on Ice***

If your route crosses frozen waterways, make sure the ice is thick enough and sound enough to support the total weight of yourself, the vehicle and its load. Be ever watchful of open water it is a sure indication that the ice thickness will vary.

Ice will also affect the control of the vehicle. Slow down and do not "gun" the throttle. This will only result in spinning of the tires and possible tip over of the vehicle. Avoid rapid braking. This again will possibly result in an uncontrolled slide and tip over of the vehicle. Slush should be avoided at all times since it could block the operation or controls of the vehicle.

### ***Riding on Snow Covered Surfaces***

When performing the pre-ride inspection, pay special attention to locations on the vehicle where snow and/or ice accumulations may obstruct visibility of the taillight and reflectors, clog ventilation openings, and interfere with the movement of control levers, switches and brake pedal. Before starting with your ATV check the steering, throttle and brake lever and pedal controls for interference free operation.

Whenever an ATV is ridden on a snow covered drive path the tire grip is generally reduced causing the vehicle to react differently to control inputs from the operator. On low grip surfaces, the steering responses are not as crisp and precise, stopping distances are lengthened and acceleration becomes sluggish. Slow down and do not "gun" the throttle. This will only result in spinning of the tires and possibly in an over steering slide of the vehicle. Avoid hard braking. This will possibly result in a straight line slide of the vehicle. Again, the best advice is to safely reduce speed in anticipation of a maneuver so to give yourself time and distance to regain total vehicle control before it spins out of your control.

As you drive your ATV over a loose snow covered surface, snow dust will be picked up in the wake turbulence of the moving vehicle and transported to contact and accumulate or melt on some exposed components including rotating parts like brake discs. Water, snow or ice may affect the response time of the brake system of your ATV. Even when not required to reduce vehicle speed apply brakes frequently to prevent ice or snow accumulation and to dry brake pads and discs. While doing so in low risk driving situations you will test for grip level and keep yourself alerted to how the vehicle reacts to your control inputs. Always keep brake pedal, footrests, floor boards, brake and throttle levers free of snow and ice. Frequently wipe snow off seat, hand grips, headlights, taillights and reflectors.

The depth of the snow cover may hide rocks, tree stumps or other objects and if it is wet may totally impede the driveability as the vehicle becomes bogged down or completely loses traction in slushy snow. Look far ahead and always be watchful of any visible clues that might indicate the presence of such obstacles. In doubt steer clear. Avoid driving on any frozen body of water before checking that the ice will safely support the ATV, its riders and its load of cargo. Remember that a given thickness of ice may be sufficient to support a snowmobile but not an ATV of an identical weight because of the smaller load bearing

surface of the four tire contact patches as compared to that of a snowmobile track and skis.

To maximize comfort and avoid frostbite, always wear clothing and ATV protective equipment appropriate for the weather conditions you will be exposed to during your ride.

At the end of each ride it is a good practice to clean the vehicle body and all moving components (e.g., brakes, steering components, drive-lines and controls) from any snow or ice accumulations. Wet snow will turn to ice during the shut down period and become more difficult to remove at the next pre-ride inspection.

Riding in snow may reduce the brakes stopping capability. Safely reduce speed and allow greater distance for braking. Snow projection may cause ice build up or snow accumulation on brake components and controls. Apply brakes frequently to prevent ice or snow accumulation.

### ***Riding on Sand***

Riding on sand or sand dunes is another unique experience, but there are some basic precautions that should be observed. Wet, deep or fine sand may create a loss of traction and cause the vehicle to slide, drop off or become “bogged” down. If this occurs look for a firmer base. Again, the best advice is to slow down and be watchful of the conditions.

When riding in sand dunes it is advisable to equip the vehicle with an antenna-type safety flag. This will help make your location more visible to others over the next sand dune. Proceed carefully should you see another safety flag ahead. Since the antenna type safety flag can snag and rebound on your body if caught, do not use it in areas where there are low hanging branches or obstacles.

### ***Riding on Loose Stones***

Riding on loose stones or gravel is very similar to riding on ice. They will affect the steering of vehicle possibly causing it to slide or tip over, especially at high speeds (resulting in operator ejection).

Again, the best advice is to slow down and be watchful of the conditions.

In addition, braking distance may be affected. Remember that “gunning” the throttle or sliding may cause loose stones to be ejected rearwards into the path of another rider. Never do it deliberately.

# IMPORTANT ON-PRODUCT LABELS (CANADA/UNITED STATES)

## Safety Hang Tag

This vehicle comes with a hang tag, which contains important information.

Any person who rides this vehicle should read and understand this information before riding.

**Y**  
**YOUTH MODEL**

THIS ATV IS FOR RECREATIONAL USE BY YOUNG OPERATORS UNDER ADULT SUPERVISION

OPERATOR ONLY - NO PASSENGERS

THIS CATEGORY ATV HAS BEEN DESIGNED TO BE USED UNDER LIMITED/RESTRICTED MAXIMUM SPEED

---

RENEGADE 70  
**(NO OPERATOR UNDER AGE 6)**  
RESTRICTED MAXIMUM SPEED:  
16 Km/h (10MPH) (FACTORY SET-UP)  
\*UNRESTRICTED MAXIMUM SPEED: 24 Km/h (15MPH)  
(SET UNDER CLOSE PARENT SUPERVISION/JUDGMENT)  
A CATEGORY Y-6+ ATV IS A YOUTH MODEL

---

RENEGADE 110  
**(NO OPERATOR UNDER AGE 10)**  
RESTRICTED MAXIMUM SPEED:  
24 Km/h (15MPH) (FACTORY SET-UP)  
\*UNRESTRICTED MAXIMUM SPEED: 48 Km/h (30MPH)  
(SET UNDER CLOSE PARENT SUPERVISION/JUDGMENT)  
A CATEGORY Y-10+ IS A YOUTH MODEL

---

TRAINING COURSE TO TEACH ATV RIDING SKILLS ARE AVAILABLE, FOR INFORMATION CONTACT YOUR DEALER.

CHECK WITH YOUR DEALER TO FIND OUT ABOUT STATE OR LOCAL LAWS REGARDING ATV OPERATION.

\*See operator's guide for the procedure  
THIS HANGTAG IS NOT TO BE REMOVED BEFORE SALE.

**WARNING**

Improper ATV use can result in SEVERE INJURY or DEATH.



ALWAYS USE AN APPROVED HELMET AND PROTECTIVE GEAR.

NEVER USE ON PUBLIC ROADS

NEVER CARRY PASSENGERS.

NEVER USE UNDER THE INFLUENCE OF DRUGS OR ALCOHOL.

**NEVER** operate:

- without proper training or instructions.
- at speed too fast for your skills or the conditions.
- on public roads - a collision can occur with another vehicle
- with a passenger - passenger affect balance and steering and increase risk of losing control.

ALWAYS:

- use proper riding techniques to avoid vehicle overturns on hills and rough terrain and in turns.
- avoid paved surfaces - pavement may seriously affect handling and control.

LOCATE AND READ OPERATOR'S GUIDE,  
FOLLOW ALL INSTRUCTIONS & WARNINGS

70K0048

## Safety Labels

Read and understand all the safety labels on your vehicle.

These labels are affixed to the vehicle for the safety of the operator or bystanders.

The safety labels on your vehicle should be considered permanent parts of the vehicle.

If missing or damaged, they can be replaced free of charge. Contact an authorized Can-Am Off-road dealer.

### **NOTE:**

In the event of any discrepancy between this operator guide and the vehicle, the safety labels on the vehicle have precedence over the labels in this document.

## General Warning Label

**⚠ WARNING**

Improper ATV use can result in SEVERE INJURY or DEATH.

			
ALWAYS USE AN APPROVED HELMET AND PROTECTIVE GEAR	NEVER USE ON PUBLIC ROADS	NEVER CARRY PASSENGERS	NEVER USE WITH DRUGS OR ALCOHOL

**NEVER operate:**

- without proper training or instructions.
- at speeds too fast for your skills or conditions.
- on public roads, a collision can occur with another vehicle.
- with a passenger, passengers affect balance and steering and increase risk of losing control.

**ALWAYS:**

- use proper riding techniques to avoid vehicle overturns on hills and rough terrain and in turns.
- avoid paved surfaces, pavement may seriously affect handling and control.

Read and understand all safety labels, locate and read operator's guide and watch the safety video using the QR code link or visit Can-am web site before operation.

Patent : [www.brp.com/en/about-brp/patents.html](http://www.brp.com/en/about-brp/patents.html)

704930416

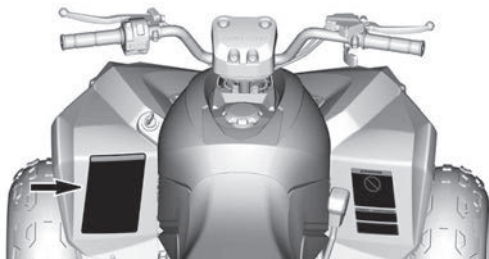



## Passenger Warning Label



## Tire Pressure and Maximum Load - Warning Label

### **⚠ WARNING**

Improper tire pressure or overloading can cause loss of control.

Loss of control can result in **SEVERE INJURY OR DEATH.**

#### **TIRE PRESSURE**

- Set with tires cold:

- Minimum	FRONT: 25 kpa	4 psi
	REAR: 25 kpa	4 psi
- Maximum	FRONT: 35 kpa	5 psi
	REAR: 35 kpa	5 psi

- Never set tire pressure below minimum. It could cause the tire to dislodge from the rim.
- Maximum Weight Capacity : 180 lbs. (82 kg). Includes weight of operator and accessories.

704909424

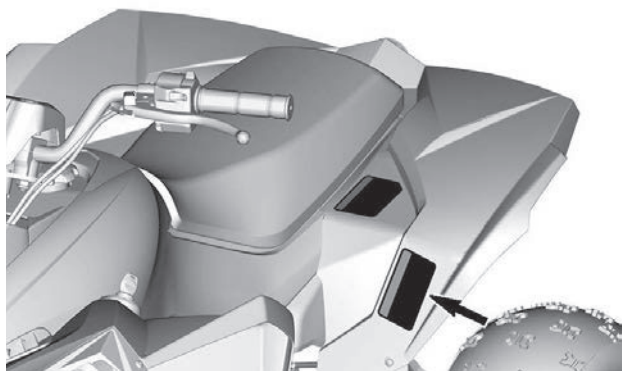

## Recommended Age/Off-Road Vehicle/ANSI / SVIA- Warning Label

Renegade 70



Renegade 110  
Renegade 110 X xc

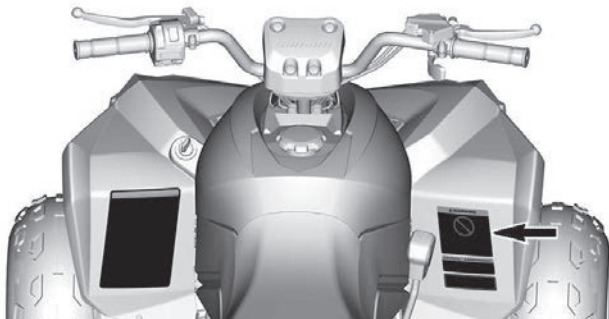
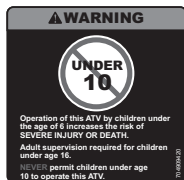

## No On-Road Use – Warning Label

**▲ WARNING / ▲ AVERTISSEMENT**

This vehicle is an off road vehicle not intended for use on public roads.

Ce véhicule est conçu pour un usage hors route et n'est pas destiné aux voies publiques.

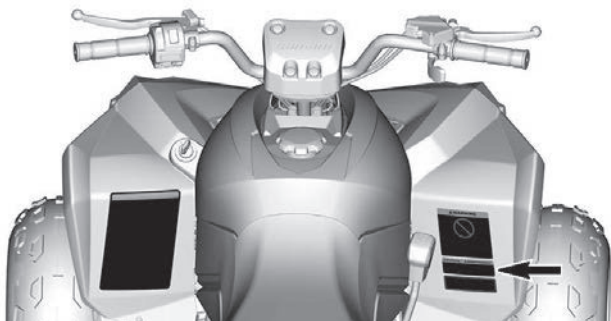

## Pulling a Load Using the Rear Bumper— Warning Label

### **⚠ WARNING**

**NEVER** attach here to pull a load.  
This can cause the vehicle to tip over.

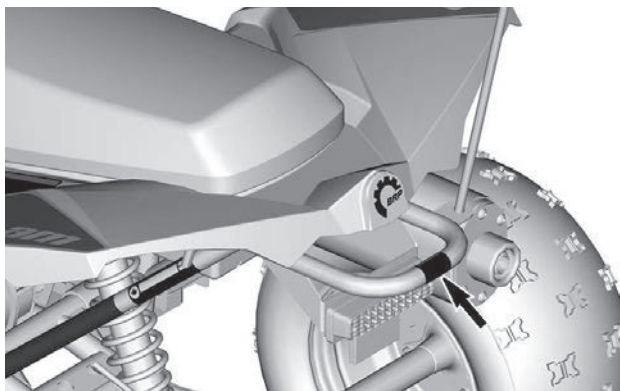

## Molded Pictogram

### Seat Pictogram

 **WARNING**

**No passenger allowed on this vehicle.**

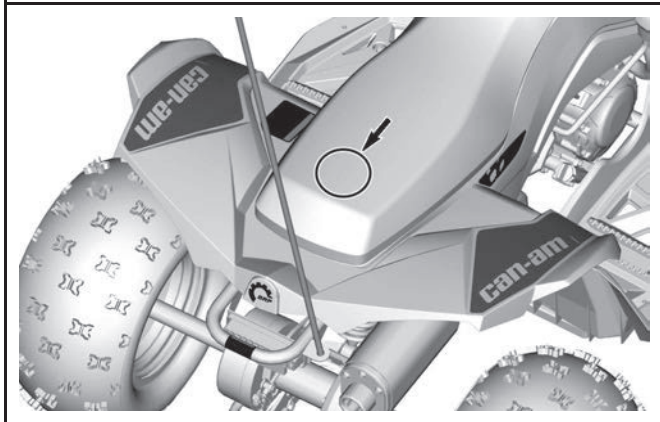

## Compliance Hang Tag

### California Proposition 65 Warning - Hang Tag

 **WARNING.** Operating, servicing and maintaining an off-road vehicle can expose you to chemicals including engine exhaust, carbon monoxide, phthalates, and lead, which are known to the State of California to cause cancer and birth defects or other reproductive harm.

To minimize exposure, avoid breathing exhaust, do not idle the engine except as necessary, service your vehicle in a well-ventilated area and wear gloves or wash your hands frequently when servicing your vehicle.

For more information go to  
[www.P65Warnings.ca.gov/products/  
passenger-vehicle](http://www.P65Warnings.ca.gov/products/passenger-vehicle)



704906872

---

## **IMPORTANT ON-PRODUCT LABELS (ALL COUNTRIES OUTSIDE CANADA/UNITED STATES)**

### **Hang Tag**

This vehicle comes with a hang tag that contains important information.

Any person who rides this vehicle should read and understand this information before riding.



## Safety Hang Tag

This vehicle comes with a hang tag and labels that contain important safety information.

Any person who rides this vehicle should read and understand this information before riding.

### WARNING

- Locate and read operator's guide. Improper ATV use can result in SEVERE INJURY or DEATH. Follow all instructions and warnings.
- Always wear ear protection.
- Always use an approved helmet and protective gear.
- Never use on public roads.
- Never carry passengers.
- Never use with drugs or alcohol.

**Y**  
**YOUTH MODEL**

THIS ATV IS FOR RECREATIONAL USE BY YOUNG OPERATORS UNDER ADULT SUPERVISION

OPERATOR ONLY - NO PASSENGERS

THIS CATEGORY ATV HAS BEEN DESIGNED TO BE USED UNDER LIMITED/RESTRICTED MAXIMUM SPEED

---

RENEGADE 110  
**(NO OPERATOR UNDER AGE 10)**  
RESTRICTED MAXIMUM SPEED:  
24 Km/h (15MPH) (FACTORY SET-UP)  
\*UNRESTRICTED MAXIMUM SPEED: 48 Km/h (30MPH)  
(SET UNDER CLOSE PARENT SUPERVISION/JUDGMENT)  
A CATEGORY Y-10+ IS A YOUTH MODEL

---

TRAINING COURSE TO TEACH ATV RIDING SKILLS ARE AVAILABLE. FOR INFORMATION CONTACT YOUR DEALER.

CHECK WITH YOUR DEALER TO FIND OUT ABOUT STATE OR LOCAL LAWS REGARDING ATV OPERATION.

\*See operator's guide for the procedure

THIS HANGTAG IS NOT TO BE REMOVED BEFORE SALE.



TOMCOMET

## **Safety Pictogram**

Read and understand all the safety labels on your vehicle.

These labels are affixed to the vehicle for the safety of the operator or bystanders.

The safety labels on your vehicle should be considered permanent parts of the vehicle.

If missing or damaged, they can be replaced free of charge. Contact an authorized Can-Am Off-road dealer.

### **NOTE:**

In the event of any discrepancy between this operator guide and the vehicle, the safety labels on the vehicle have precedence over the labels in this document.

## General Warning Label

### WARNING

- Always use an approved helmet and protective gear.
- Locate and read operator's guide. Improper ATV use can result in SEVERE INJURY or DEATH. Follow all instructions and warnings.
- Always wear ear protection.
- Never use on public roads.
- Never carry a passenger.
- Never use with drugs or alcohol.













Safety Video

  
[https://  
can-am.brp.com  
/off-road/safety](https://can-am.brp.com/off-road/safety)







Patent : [www.brp.com/en/about-brp/patents.html](http://www.brp.com/en/about-brp/patents.html)

8185

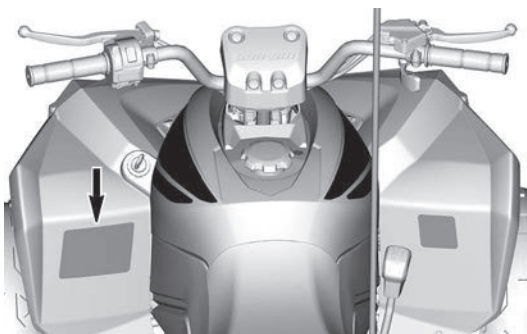

## Passenger Warning Label

 **WARNING**

- Read the entire operator's guide and watch the safety video.
- **NEVER** carry a passenger.

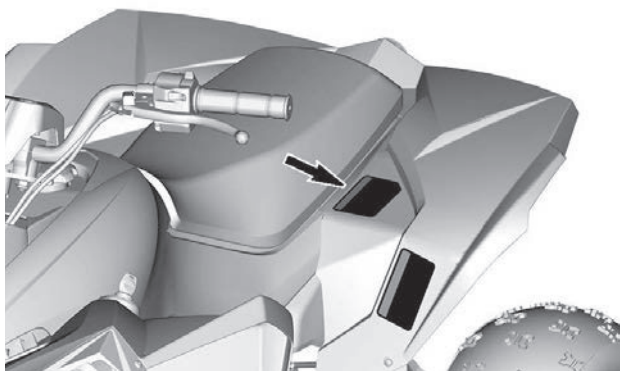

## Tire Pressure and Maximum Load - Warning Label

### WARNING

- Locate and read the operator's guide. Improper tire pressure and overloading can cause loss of control, resulting in SEVERE INJURY or DEATH.
- ALWAYS maintain proper tire pressure as shown.
- NEVER exceed the load capacity of 82 kg (180 lb) including the weight of operator, cargo, and accessories (and including trailer tongue weight if applicable).

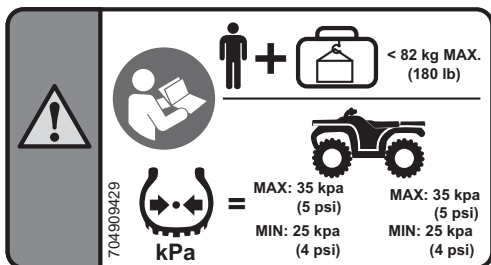

704909429

**kPa**

MAX: 35 kPa  
(5 psi)

MIN: 25 kPa  
(4 psi)

MAX: 35 kPa  
(5 psi)

MIN: 25 kPa  
(4 psi)

< 82 kg MAX.  
(180 lb)

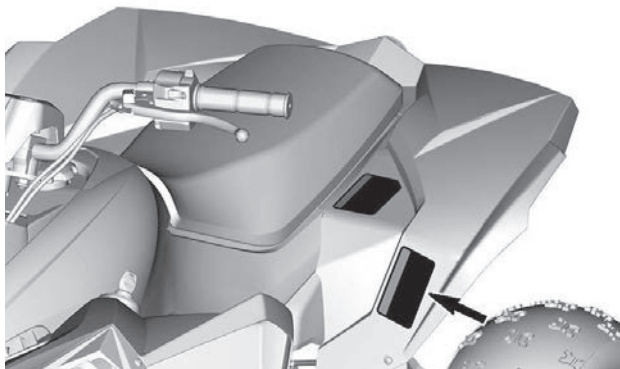

## Recommended Age – Warning Label

 **WARNING**

Operating of this ATV if you are under the age of 10 increases your chance of **SEVERE INJURY OR DEATH**.  
**NEVER** operate this ATV if you are under age 10.

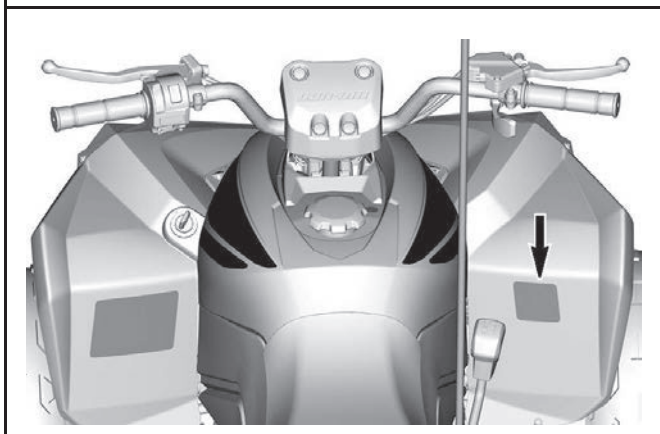
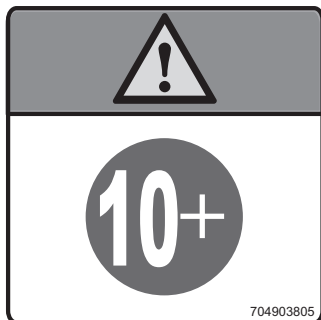

## Pulling a Load Using the Rear Bumper — Warning Label

 **WARNING**

**NEVER** attach to the bumper to pull a load. This can cause the vehicle to tip over.

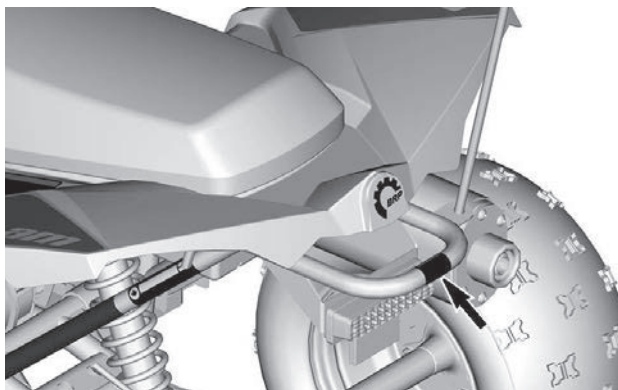
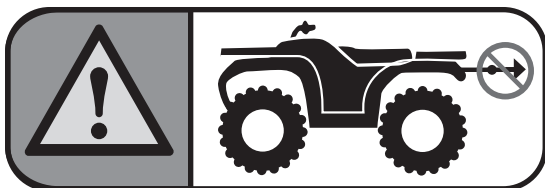

## Molded Pictogram

### Seat Pictogram

 **WARNING**

**No passenger allowed on this vehicle.**

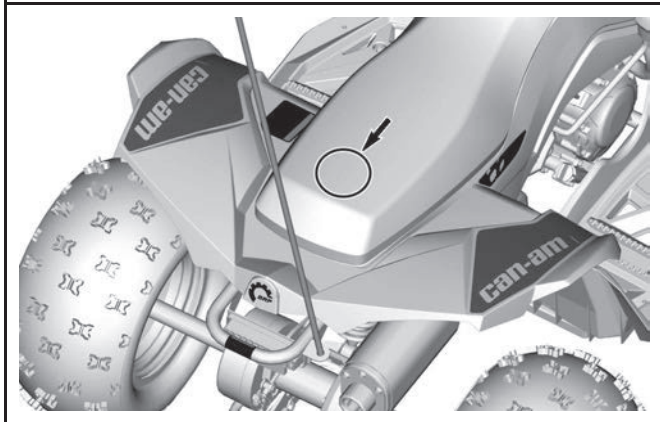



---

## REPORTING SAFETY DEFECTS

In Canada, if you believe that your vehicle has a defect which could cause a crash or could cause injury or death, you should immediately inform Transport Canada in addition to notifying Bombardier Recreational Products Inc.

If Transport Canada receives similar complaints, it may open an investigation, and if it finds that a safety defect exists in a group of vehicles, it may order a recall and remedy campaign. However, Transport Canada cannot become involved in any individual problems between you, your dealer or Bombardier Recreational Products Inc.

### To contact Transport Canada:



819-994-3328 (Gatineau-Ottawa area or internationally)  
Toll free : 1 800-333-0510 (in Canada)



Transport Canada - ASFAD  
330 Sparks Street  
Ottawa, ON  
K1A 0N5



<https://www.tc.gc.ca/recalls>

This page is intentionally blank

# VEHICLE INFORMATION

---

## PRIMARY CONTROLS

This section provides basic information on the functions of the various controls of your vehicle. For more details on how to operate a control in conjunction with others, refer to *Operating Instructions*.

### Throttle Lever

The throttle lever is located on the RH side of the handlebar.

When pushed forward, it increases engine speed and allows engagement of the transmission.

When it is released, the engine speed should automatically return to idle and the vehicle should gradually slow down.

#### NOTE:

The engine idle speed is preset at the factory. If the idle speed is not satisfactory, consult an authorized Can-Am Off-road dealer for adjustment.

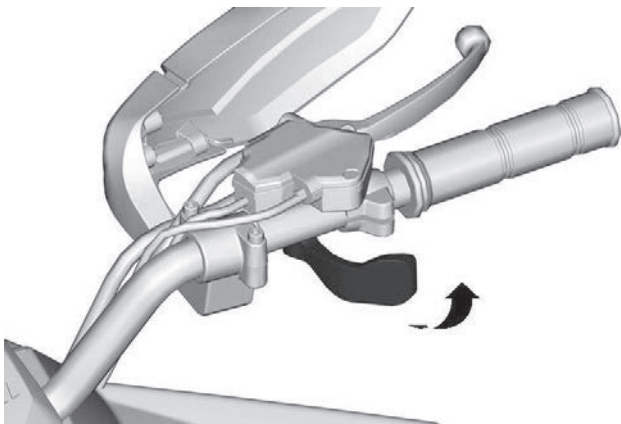

#### **RH HANDLEBAR**

The vehicle is also equipped with a throttle release switch. If the throttle should freeze or stick in the open position when released, the throttle release switch will limit the engine speed to idle speed.

**⚠ WARNING**

Check throttle lever operation before you start the engine. If the throttle lever does not function smoothly, check for the cause. Correct the problem before riding the vehicle. Consult an authorized Can-Am Off-road dealer if you cannot find or solve the problem yourself.

**Speed Limiter**

This vehicle is equipped with an adjustable speed limiter screw on the throttle lever housing. The speed limiter prevents the throttle from being fully opened, even when the throttle lever is pushed fully forward. This limits the available engine power and, therefore, vehicle speed.

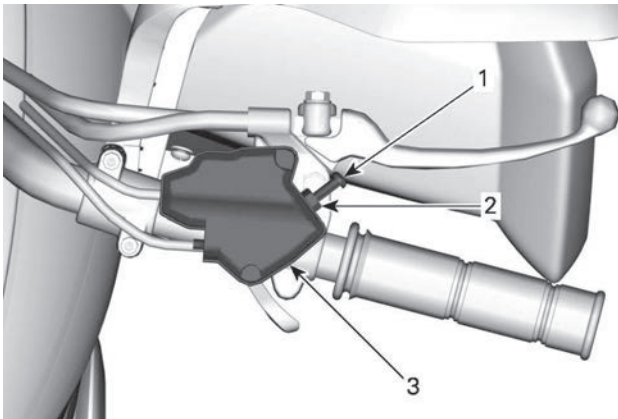
**RH HANDLEBAR**

1. Speed limiter screw
2. Locknut
3. Throttle lever cable housing

**⚠ WARNING**

Adults should always limit the maximum restricted speed within the ability and capacity of the child to operate the vehicle safely. Never allow the child to adjust the speed limiter screw.

BRP recommends that all beginners start off with the speed limiter screw turned in while they learn.

Adults can gradually adjust the speed limiter screw to increase the maximum speed as the beginner becomes more familiar with the operation of the vehicle. Refer to the following table.

Speed Setting	Renegade 70	Renegade 110 Renegade 110 Xxc
Factory limited speed	16 km/h (10 MPH)	24 km/h (15 MPH)
Maximum unrestricted speed	24 km/h (15 MPH)	48 km/h (30 MPH)

 **WARNING**

**When traveling downhill, gravity can increase the vehicle speed above the desired maximum speed set using the speed limiter screw.**

 **WARNING**

**Improper adjustment of the speed limiter screw could damage the throttle cable and impair throttle lever operation. Failure to follow the adjustment recommendations could lead to an accident.**

To adjust the speed limiter screw, loosen the locknut and then turn the speed limiter screw accordingly. Turning the screw clockwise reduces throttle lever travel; turning the screw counterclockwise increases throttle lever travel.

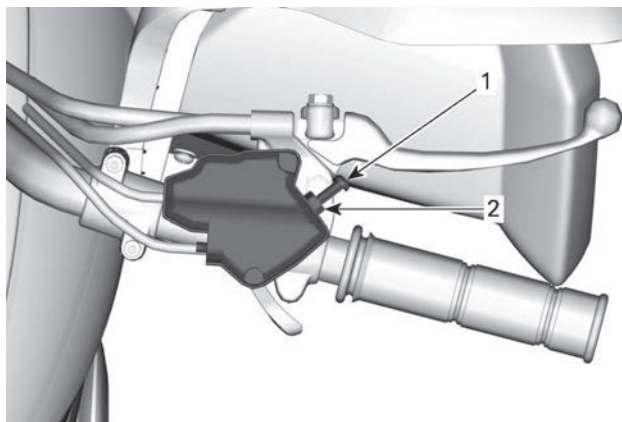

1. Locknut
2. Speed limiter screw

Tighten the locknut after adjustment.

## RH Brake Lever

The RH brake lever is located on the RH side of the handlebar.

When the lever is pulled toward the handlebar, the front brake is applied. When released, it should automatically return to its original position. Braking effect is proportional to the force applied on the lever.

### WARNING

**Always apply both brakes (RH and LH brake levers) at the same time while releasing the throttle. Otherwise, you could lose control of the vehicle, resulting in serious injury.**

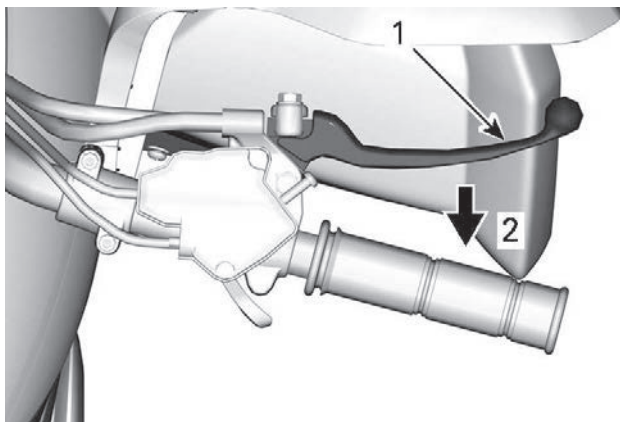

### **RH HANDLEBAR**

1. Brake lever
2. To apply brake

### **LH Brake Lever**

The LH brake lever is located on the LH side of the handlebar.

When the lever is pulled toward the handlebar, the rear brake is applied. When released, it should automatically return to its original position. Braking effect is proportional to the force applied on the lever.

#### **! WARNING**

**Always apply both brakes (RH and LH brake levers) at the same time while releasing the throttle. Otherwise, you could lose control of the vehicle, resulting in serious injury.**

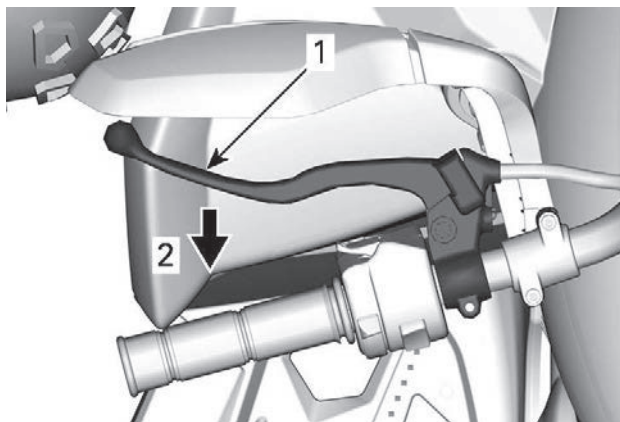

**LH HANDLEBAR**

1. Brake lever
2. To apply brake

**Parking Brake**

When applied, the parking brake prevents the vehicle from moving. This is useful during transportation or when the vehicle is not in operation.

**⚠ WARNING**

Always use the parking brake when the vehicle is not in operation.

**⚠ WARNING**

Make sure the parking brake is fully disengaged before operating the vehicle. Riding the vehicle with a continuous pressure on the brakes may cause damage to the brake system and a loss of braking capacity and/or fire.

**Renegade 70**

The parking brake lock button is located on the RH brake lever.

**To engage the parking brake mechanism:** Squeeze the RH brake lever and press the parking brake lock button down, then release the brake lever. The brake lever is now held in applying the front brake(s).

**To release the parking brake mechanism:** Squeeze the brake lever. The parking brake lock button should automatically return to its original position. The brake lever should return to its resting position.

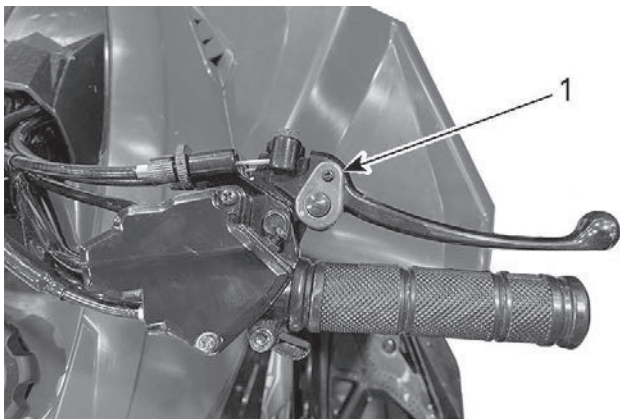

**RH BRAKE LEVER – RENEGADE 70**

1. Parking brake lock button

**Renegade 110 and Renegade 110 X xc**

The parking brake lock lever is located on the LH brake lever.

**To engage the parking brake mechanism:** Squeeze the LH brake lever and hold it as you engage the lever lock, then release the lever against the lock. The brake lever is now held in applying the rear brake(s).

**To release the parking brake mechanism:** Squeeze the brake lever. The lever lock should automatically return to its original position. The brake lever should return to its resting position.

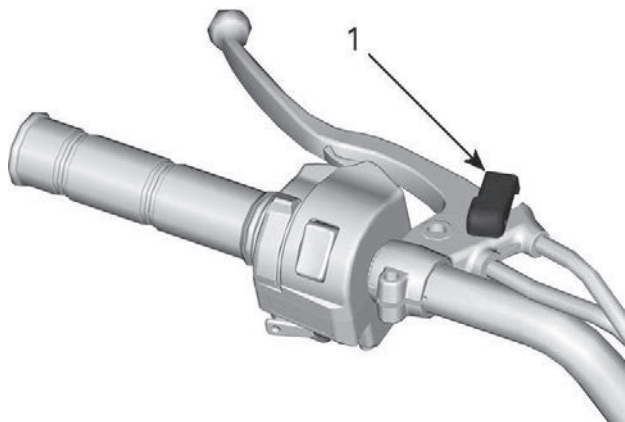

**LH BRAKE LEVER — RENEGADE 110**

1. *Lever lock*

## SECONDARY CONTROLS

### Transmission Lever

A three-position transmission lever is located on the RH side of the vehicle, near the engine.

#### NOTICE

Always stop the vehicle completely and apply the brakes prior to moving the transmission lever. Make sure the engine is at idle.

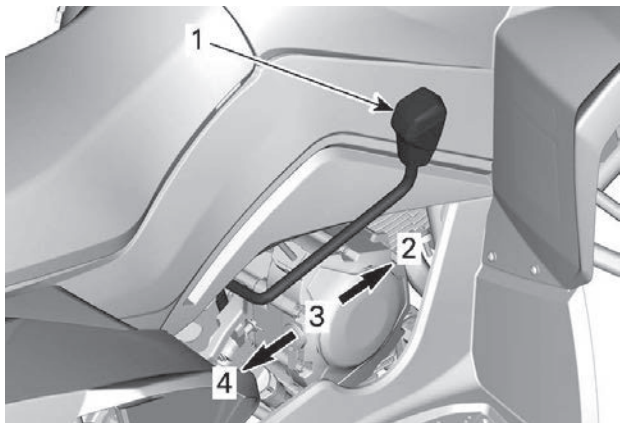

#### TRANSMISSION LEVER PATTERN

1. Transmission lever
2. Forward (F)
3. Neutral (N)
4. Reverse (R)

To change the transmission position, completely stop the vehicle, apply the brakes, then move the lever to the desired position. Do not force the lever.

#### ⚠ WARNING

Before moving the vehicle in reverse, ensure that the path behind it is clear of obstacles or bystanders. Remain seated.

If you experience shifting problems, consult an authorized Can-Am Off-road dealer or other qualified person for adjustment of the shift linkage.

***F: Forward***

This is the normal driving gear. It allows the vehicle to reach its maximum speed.

***N: Neutral***

This position disengages the transmission to allow manual vehicle movement or towing.

***R: Reverse***

This allows the vehicle to go backwards.

 **WARNING**

Before operating the vehicle in reverse, ensure the path behind is clear of obstacles or bystanders. BRP recommends that you remain seated. Avoid standing up. Your weight could shift forward against the throttle lever causing an unexpected acceleration and loss of control.

## Multifunction Switch

The multifunction switch is located on the LH side of the handlebar.

The controls located on the multifunction switch are the following:

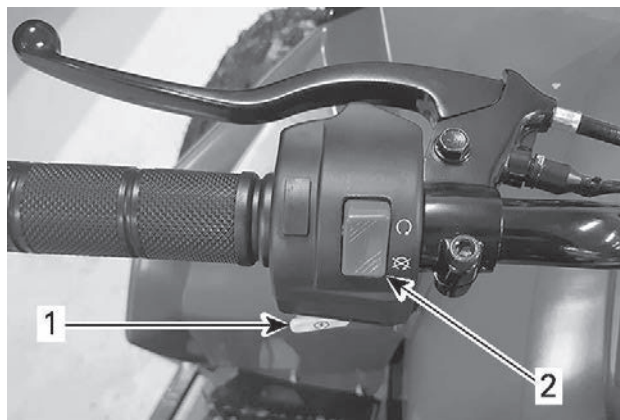

**MULTIFUNCTION SWITCH**

1. Engine start button
2. Emergency engine stop switch

**Emergency Engine Stop Switch**

The emergency engine stop switch can be used to stop the engine quickly, or as an emergency control. When this switch is in the STOP position, there is no electrical power to the vehicle and the engine cannot run.

To stop the engine, fully release the throttle lever then set the emergency engine stop switch to the STOP position. Then turn the ignition to the OFF position

**NOTE:**

Although the engine can be stopped by turning the ignition key to the OFF position, we recommend that the engine be stopped by setting the emergency engine stop switch to the STOP position.

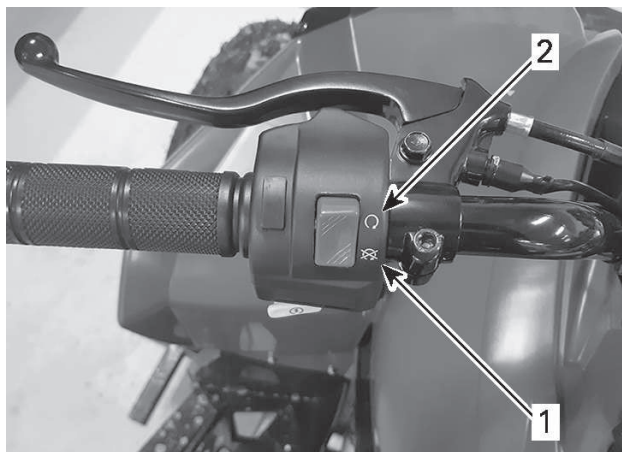

### **EMERGENCY ENGINE STOP SWITCH**

1. *STOP* position
2. *RUN* position

### **Engine Start Button**

The engine start button is located to the bottom of the multifunction switch.

This button is used to start the engine. Refer to *Starting the Engine* for complete procedure.



1. Engine start button



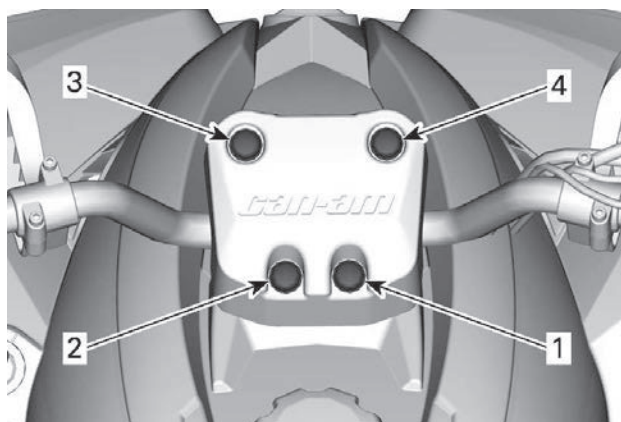

## Indicator Lamps

The indicator lamps are located near the middle of the handlebar.



## INDICATOR LAMPS



1	Neutral (N)		Transmission lever is in the neutral position.
2	Reverse (R)		Transmission lever is in the reverse position.
3	Low Fuel		Low fuel. The vehicle can continue to operate for another 11 - 16 km (7 - 10 mi).
4	Check Engine		Flashing: Overheated engine. Engine power is automatically reduced. Continuous: An EFI fault has occurred. To avoid serious engine damage, do not operate the vehicle. Consult an authorized Can-Am Off-road dealer.

## Ignition Switch

The ignition switch is located just above the left-front fender.

It is a key-operated switch with two positions: OFF and ON.

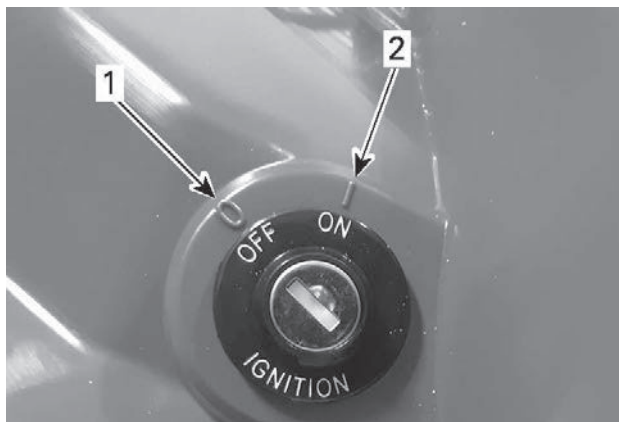

**IGNITION SWITCH**

1. OFF position
2. ON position

Before starting the engine, insert the key into the switch and turn it clockwise to the ON position. To remove the key, turn it to the OFF position and then pull it out. Always remove the key when the vehicle is not in use or when transporting the vehicle.

Even if the engine can be stopped by turning the ignition key to the OFF position, it is greatly recommended to use the emergency engine stop switch. However, do not forget to turn the ignition key to the OFF position after stopping the engine with the emergency engine stop switch to avoid draining the battery.

---

## EQUIPMENT

### Seat

#### *Removing the Seat*

The seat latch is located under the left-rear fender. Pull the latch rearward while gently lifting the rear of the seat. Then pull the seat rearward to remove it.

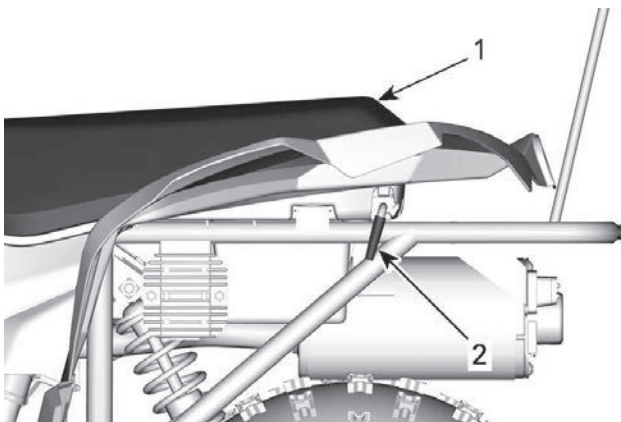

**LH SIDE OF VEHICLE**

- 1. Seat
- 2. Seat latch

#### *Installing the Seat*

Insert the front tab of the seat into the frame hook. When the seat rests in its position, firmly push the seat down to latch it.

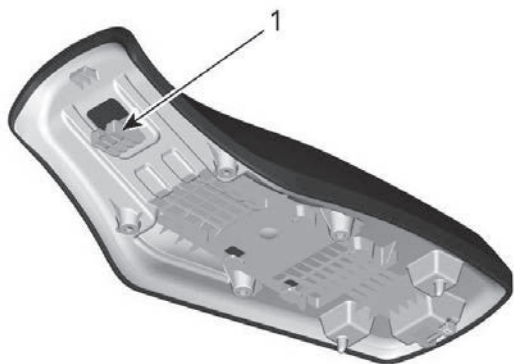

**UNDERSIDE OF SEAT**

1. Seat tab

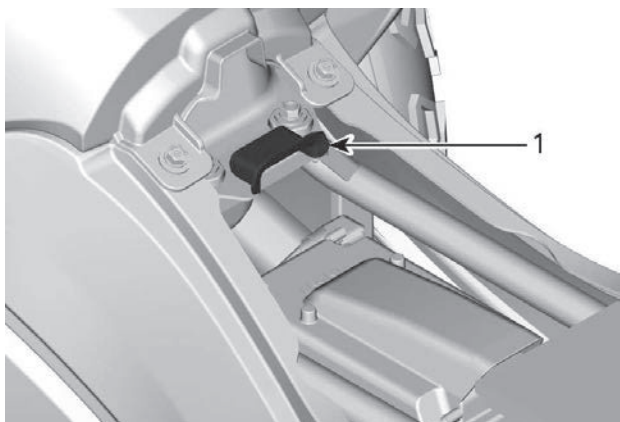

1. Frame hook

**⚠ WARNING**

**Make sure the seat is securely latched before riding the vehicle.**

---

# FUEL

## Fuel Requirements

### NOTICE

**Always use fresh gasoline. Gasoline will oxidize; the result is a loss of octane, volatile compounds, and the production of gum and varnish deposits which can damage the fuel system.**

Alcohol fuel blending varies by country and region. This engine was designed to operate using the recommended fuels. However, be aware of the following:

- Use of fuel containing alcohol above the percentage specified by government regulations is not recommended and can result in the following problems in the fuel system components:
  - Starting and operating difficulties.
  - Deterioration of rubber or plastic parts.
  - Corrosion of metal parts.
  - Damage to internal engine parts.
- Inspect frequently for the presence of fuel leaks or other fuel system abnormalities if you suspect the presence of alcohol in gasoline exceeds the current government regulations.
- Alcohol-blended fuels attract and hold moisture, which may lead to fuel phase separation and can result in engine performance problems or engine damage.

### **Recommended Fuel**

Use regular unleaded gasoline with a minimum AKI (RON+MON)/2 octane rating of 87, or a RON octane rating of 92.

Use unleaded gasoline containing a MAXIMUM of 10% ethanol.



### NOTICE

**Never experiment with other fuels. Engine or fuel system damage may occur with the use of an inadequate fuel.**

**NOTICE**

Do NOT use fuel from fuel pumps labeled E85.

**United States of America**

Use of fuel labeled E15 is prohibited by U.S. EPA regulations.

**Fueling Procedure**** WARNING**

- Do not allow children to refuel the vehicle.
- Always use extreme caution when handling fuel.
- Always stop the engine before refueling. Open the cap slowly.
- If a differential pressure condition is noticed (whistling sound heard when loosening the fuel tank cap) have the vehicle inspected and/or repaired before further operation.
- Fuel vapors are flammable and explosive under certain conditions.
- Never use an open flame to check the fuel level.
- Never smoke or allow a flame or spark in the vicinity.
- Always work in a well-ventilated area.
- Never top off the fuel tank before placing the vehicle in a warm area. As the temperature increases, fuel expands and may overflow.
- Always wipe off any fuel or oil spillage from the vehicle.
- If fuel spills on your skin or clothing, immediately wash it off with soap and water and change your clothing.

1. Stop the engine.
2. Do not allow anyone to remain seated on the vehicle while fueling.
3. Unscrew the fuel tank cap counterclockwise to remove it.

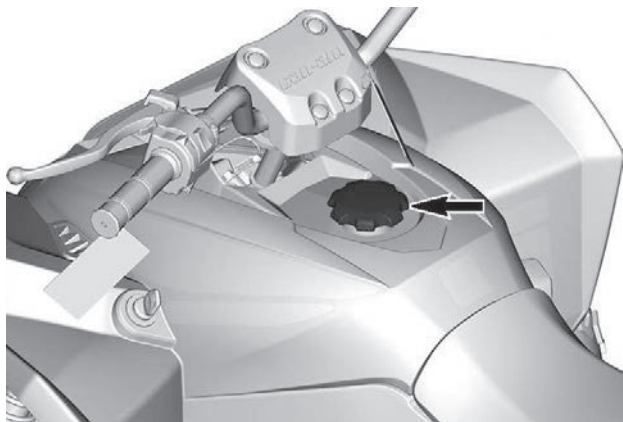
**FUEL TANK CAP**

4. Insert the spout into the filler neck.
5. Pour the fuel slowly, allowing time for the air in the tank to escape and preventing back flow. Be careful not to spill fuel.
6. Stop pouring when the fuel level reaches the bottom of the filler neck. **Do not overfill. Do not fill the tank neck.**
7. Fully tighten the fuel tank cap (clockwise).

---

## BREAK-IN PERIOD

### Operating During Break-In

A break-in period of 10 operating hours is required before running the vehicle at sustained full throttle.

After the break-in period, the vehicle should be inspected by an authorized Can-Am Off-road dealer, repair shop or person of your own choosing. Refer to *Maintenance*.

#### **Engine**

During the break-in period:

- Avoid full throttle operation.
- Maximum throttle should not exceed 3/4.
- Avoid sustained accelerations.
- Avoid prolonged cruising speeds.
- Avoid engine overheating.

However, brief accelerations and speed variations contribute to a good break-in.

#### **Brakes**

 **WARNING**

**The new brakes will not perform to their maximum efficiency until their burnishing is completed. To achieve a good burnishing, bring the vehicle to a complete stop for a minimum of 50 times using brakes. Readjust brakes if needed, refer to *Mechanical Brakes*.**

#### **Drive Belt**

A new belt requires a break-in period of 50 km (30 mi).

During the break-in period:

- Avoid strong accelerations and decelerations
- Avoid pulling a load
- Avoid high speed cruising.



# OPERATING INSTRUCTIONS

## Starting the Engine

### WARNING

Always proceed with the pre-ride inspection prior to operating the vehicle. Always check for proper operation of critical controls, safety features and mechanical components before starting.

### NOTICE

Do not operate the vehicle immediately after starting. Allow the engine to run for several minutes before operating. This will avoid damage to the engine.

1. Set the transmission lever to the neutral (N) position.
2. Apply the parking brake.
3. Sit on the vehicle.
4. Set the emergency engine stop switch to the RUN position.

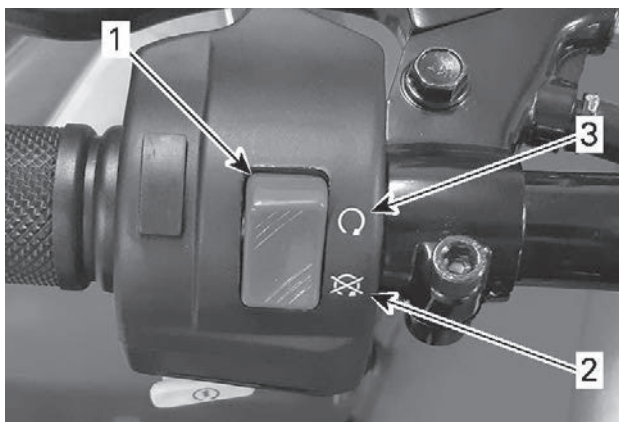

### MULTIFUNCTION SWITCH — LH HANDLEBAR

1. *Emergency engine stop switch*
2. *STOP position*
3. *RUN position*
5. Insert the key into the ignition switch and turn it clockwise to the ON position.

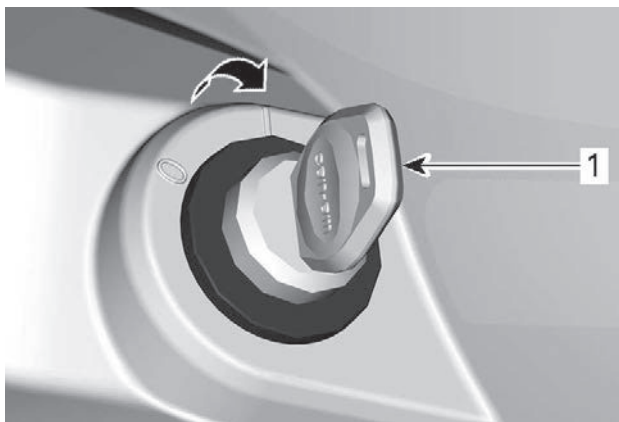

1. *Ignition key*

6. Pull and hold the LH brake lever. If the brake is not applied, the engine will not start.
7. Press and hold the engine start button until the engine starts. Do not push the throttle lever while starting.

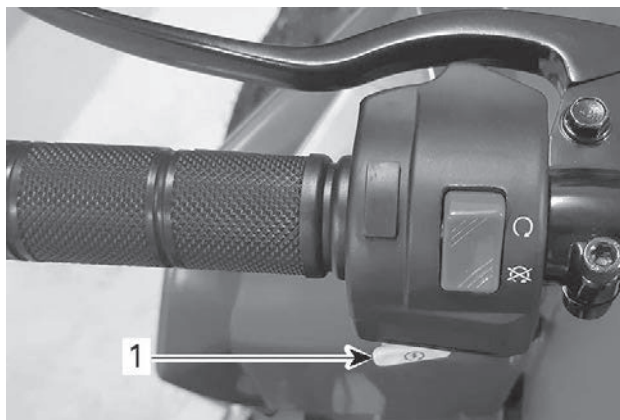

### MULTIFUNCTION SWITCH

1. Engine start button

### NOTICE

Do not hold the start button for more than five seconds. Wait five seconds between starting attempts, to allow the starter cool. Be careful not to drain the battery.

8. Release the engine start button immediately after the engine has started and then release the brake.

## Stopping the Engine

### ⚠ WARNING

Avoid parking on a slope.

1. Release the throttle and completely stop the vehicle.
2. Apply the parking brake.
3. Set the transmission lever to the forward (F) position.
4. Set the emergency engine stop switch to the STOP position.
5. Turn the ignition key to the OFF position.
6. Remove the key from the ignition switch.

## Shifting the Transmission

1. Let engine idle to warm up.
2. Apply brakes and set the transmission selector lever to "F" (forward), or "R" (reverse).
3. Release brakes.

 **WARNING**

**Make sure the parking brake is fully disengaged before operating the vehicle.**

**NOTICE**

**When changing from forward to reverse, or vice-versa, always completely stop the vehicle and apply the brake prior to moving the transmission lever.**

**NOTE:**

The engine will stop if any shifting is done at high RPM.

## TUNE YOUR RIDE

### Adjusting the Suspension

**⚠ WARNING**

Suspension adjustment could affect vehicle handling. Always take time to familiarize yourself with the vehicle's behavior after any suspension adjustment has been made.

**⚠ WARNING**

Left and right front shock adjustment must always be set to the same position. Never adjust one shock only. Uneven adjustment can cause poor handling and loss of stability, which could lead to an accident. Follow the adjustment procedure carefully, or consult your Can-Am Off-road dealer for service.

#### *Spring Preload Adjustment*

1. Shorten the springs for a firmer ride and rough road conditions.
2. Lengthen the springs for a softer ride and smooth road conditions.
3. Adjust the spring preload by turning the adjustment cam or ring accordingly.

#### *Renegade 70 / Renegade 110*

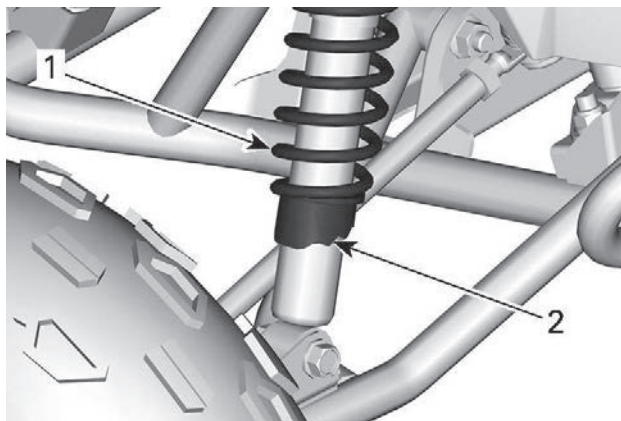

#### **FRONT SUSPENSION**

1. *Front spring*
2. *Turn adjustment cam*

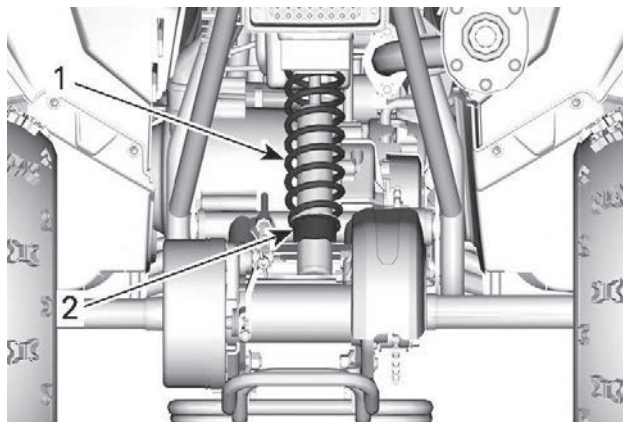

**REAR SUSPENSION**

1. Rear spring
2. Turn adjustment cam

**Renegade 110 Xxc**

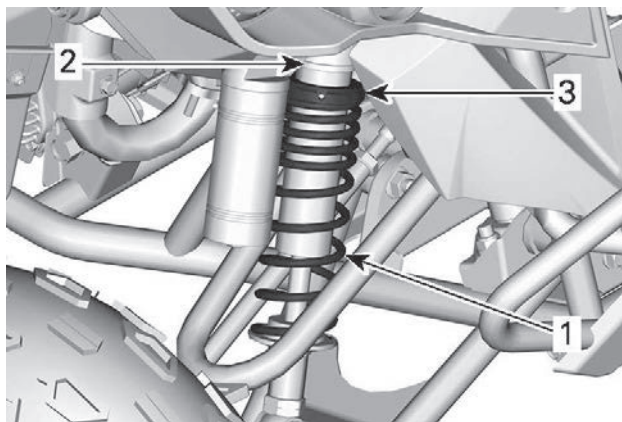
**FRONT SUSPENSION**

1. Front spring
2. Loosen locking ring
3. Turn adjustment ring

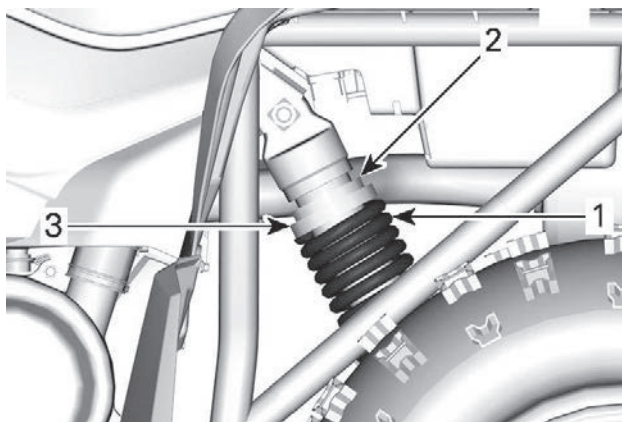
**REAR SUSPENSION — LH SIDE OF VEHICLE**

1. Rear spring
2. Loosen locking ring
3. Turn adjustment ring

## VEHICLE TRANSPORTATION

When transporting this vehicle, secure it to a trailer using suitable tie-down straps. The use of ordinary ropes is not recommended.

### WARNING

**Do not tow this vehicle behind a car or other vehicle. Always use a trailer. Never tip this vehicle on end for transporting. The vehicle must be in its normal operating position (on all four wheels), facing toward the front of the transporting vehicle.**



Remember to:

- Stop the engine and apply the parking brake.
- Put the transmission in gear.
- Secure the fuel cap and oil cap. Make sure the seat is latched.
- Remove the safety flag.

### NOTICE

**Do not attempt to secure the vehicle by its rack, bumper or handlebars. Instead, use the tie-down points identified below.**

In the front of the vehicle, secure the tie-down straps to the suspension or frame tubes, not the bumper.

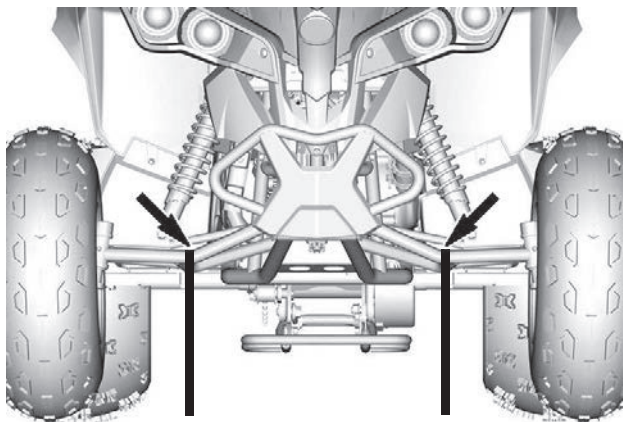

**ALL MODELS — FRONT TIE-DOWN POINT LOCATIONS**

In the rear of the vehicle, tie the strap around the grab bar.

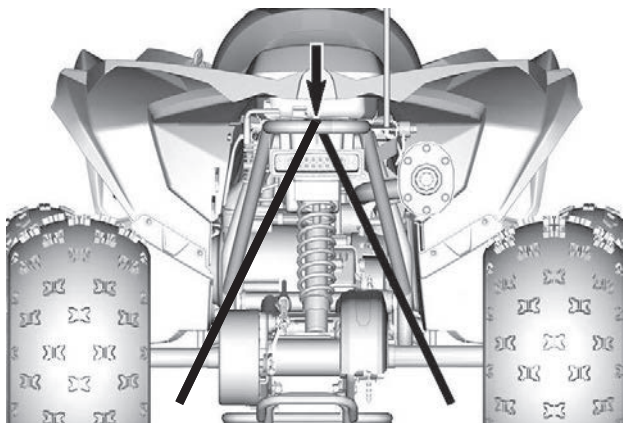
**ALL MODELS — REAR TIE-DOWN POINT LOCATION****NOTICE**

Securing the vehicle at other locations may damage the vehicle.

This page is intentionally blank

# MAINTENANCE

---

## MAINTENANCE SCHEDULE

Maintenance is very important for keeping your vehicle in safe operating condition. The vehicle should be serviced as per maintenance schedule.

The maintenance schedule does not exempt the pre-ride inspection.



**Failure to properly maintain the vehicle according to the maintenance schedule and procedures can make it unsafe to operate.**

### EPA Regulation - Canadian and USA Vehicles

**A repair shop or person of the owner's choosing may maintain, replace, or repair** emission control devices and systems. These instructions do not require components or service by BRP or authorized Can-Am Off-road dealers.

Although an authorized Can-Am Off-road dealer has an in-depth technical knowledge and tools to service your vehicle, the emission-related warranty is not conditioned on the use of an authorized Can-Am Off-road dealer or any other establishment with which BRP has a commercial relationship.

Proper maintenance is the owner's responsibility. A warranty claim may be denied if, among other things, the owner or operator caused the problem through improper maintenance or use.

For emission-related warranty claims, BRP is limiting the diagnosis and repair of emission-related parts to the authorized Can-Am Off-road dealers. For more information, please refer to the *US EPA Emission-Related Warranty* contained in the *Warranty* section.

You must follow the instructions for fuel requirements in the fueling section of this manual. Even if gasoline containing greater than ten volume percent ethanol is readily available, the US EPA issued a prohibition against the use of gasoline containing greater than 10 vol% ethanol that applies to this vehicle. The use of gasoline containing greater than 10 vol% ethanol with this engine may harm the emission control system.

### Severe Dusty Conditions

If your vehicle is used in the following conditions, refer to the **SEVERE DUTY** table of the maintenance chart:

- Repeated hauling loads at more than 75% the maximum capacity.
  - The increased workload applied to the drive system accelerates the differential, gearbox / transmission, and engine oil life. This

reduces internal component longevity if not replaced more frequently.

- Driving at excessive speeds for a prolonged amount of time.

Higher than average utility / commercial use requires more frequent fluid / wear component replacement than regular trail, recreational, or occasional utility purposes.

### **Air Filter Maintenance Guideline**

Air filter maintenance should be adjusted according to riding conditions.

Air filter maintenance must be increased in frequency in the following dusty conditions:

- Riding on dry sand
- Riding on dry dirt covered surfaces
- Riding on snow covered surfaces
- Riding on dry gravel roads or similar conditions.

Riding in a group under these conditions increases the frequency of the air filter maintenance.

## **Maintenance Schedule**

Ensure that proper maintenance is performed at the recommended intervals, as indicated in the table. Individual maintenance tasks are identified as follows:

**NOTE:** Maintenance schedule is based on an average speed usage of 16 km/h (10 MPH).

<b>A = Adjust      L = Lubricate</b> <b>C = Clean        R = Replace</b> <b>I = Inspect      T = Torque</b>		<b>At Break-In (5 Hours or 1 Month*)</b>	<b>Every 30 Hours, 1 Year or 500 km (300 mi)*</b>	<b>Every 60 Hours, 2 Years or 1,000 km (600 mi)*</b>
<b>Engine</b>				
Engine oil		R	R	
Engine oil strainer		C	C	
Valve clearance				I, A

MAINTENANCE SCHEDULE

<b>A = Adjust</b> <b>C = Clean</b> <b>I = Inspect</b>	<b>L = Lubricate</b> <b>R = Replace</b> <b>T = Torque</b>	<b>At Break-In (5 Hours or 1 Month*)</b>	<b>Every 30 Hours, 1 Year or 500 km (300 mi)*</b>	<b>Every 60 Hours, 2 Years or 1,000 km (600 mi)*</b>
Spark plug				R Every 60 Hours or 1,000 km (600 mi)
<b>Air and Fuel Delivery</b>				
Engine air filter**			C, L	
Air delivery components and function (ducts, hoses, clamps)			I	
Fuel components and function (fuel cap, hoses, clamps, tank fixation)		I	I	
<b>Exhaust</b>				
Muffler spark arrester			C	
Debris around exhaust pipe and muffler area		C	C	
Exhaust components (gaskets, pipes, muffler condition)			I, T	
<b>Electrical</b>				
Battery connections and condition		I	I	
Operation of control switches and lighting		I		
Electrical harness routing			I	

<b>A = Adjust      L = Lubricate</b> <b>C = Clean        R = Replace</b> <b>I = Inspect      T = Torque</b>		<b>At Break-In (5 Hours or 1 Month*)</b>	<b>Every 30 Hours, 1 Year or 500 km (300 mi)*</b>	<b>Every 60 Hours, 2 Years or 1,000 km (600 mi)*</b>
<b>Drive</b>				
CVT components and function				I, C, L
Gearbox position lever operation			I, A	
Gearbox oil	I		I, R	
Tires (pressure and wear)			I, A	
Wheel bolts	T		T	
Wheel bearing				I
Drive components and function (Drive Chain, Roller and Sprockets)	I, A, L		I, A, L	
<b>Steering</b>				
Steering components and function	T		I, T	
Steering alignment			I, A	
Throttle operation	I		I	
Throttle cable	A		I, L, A	
<b>Brake</b>				
Brake components and function	I, A		I, A	

MAINTENANCE SCHEDULE

<b>A = Adjust</b> <b>L = Lubricate</b> <b>C = Clean</b> <b>R = Replace</b> <b>I = Inspect</b> <b>T = Torque</b>	<b>At Break-In (5 Hours or 1 Month*)</b>	<b>Every 30 Hours, 1 Year or 500 km (300 mi)*</b>	<b>Every 60 Hours, 2 Years or 1,000 km (600 mi)*</b>
Brake cables	A, L	A, L	
<b>Suspension</b>			
Suspension components and function		I, L, T	
<b>Body</b>			
Body panels and components hardware	I, T	I, T	

\*Whichever comes first

\*\*Increase frequency in severe dusty conditions



---

## MAINTENANCE PROCEDURES

This section includes instructions for basic maintenance procedures.

 **WARNING**

Turn off the engine and follow these maintenance procedures when performing maintenance. If you do not follow proper maintenance procedures you can be injured by hot parts, moving parts, electricity, chemicals or other hazards.

 **WARNING**

Should removal of a locking device be required (e.g. lock tab, self-locking fastener, etc.), always replace it with a new one.

### Engine Oil

#### *Engine Oil Level*

**NOTICE**

Check the oil level frequently and adjust as necessary. Do not overfill. Operating the vehicle with an improper oil level may severely damage engine. Wipe off any spillage.

**NOTE:**

While checking the oil level, visually inspect the engine area for leaks.

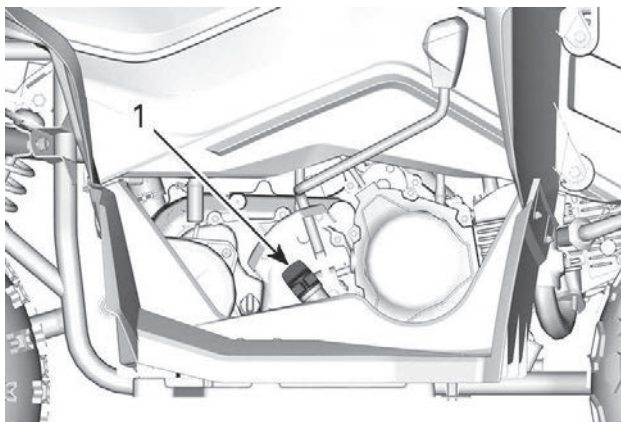

**RH SIDE OF ENGINE**

1. Dipstick

1. Place the vehicle on a level surface.
2. Unscrew the dipstick, remove it and wipe it clean.
3. Reinstall the dipstick and **screw it in completely**.
4. Remove the dipstick and check the oil level. It should be at or near the upper mark.

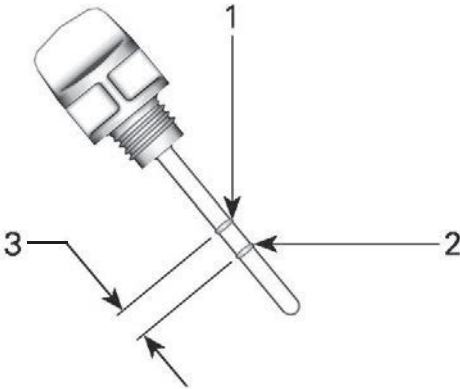

### **DIPSTICK**

1. Full
2. Add
3. Operating range

5. To add oil, remove the dipstick. Place a funnel in the dipstick hole to avoid spillage.
6. Add a small amount of oil and recheck the oil level.
7. Repeat until the oil level reaches the dipstick's upper mark. **Do not overfill.**
8. Completely tighten the dipstick.

### **Recommended Engine Oil**

Your ATV's engine was validated using XPS™ oil.

BRP recommends the use of its XPS engine oil or an equivalent at all times.

Damage caused by the use of an oil not suitable for the engine may not be covered by the BRP Limited Warranty.

### XPS Recommended Engine Oil

General purpose: XPS 10W50 synthetic oil  
Cold temperature: XPS 0W40 Synthetic oil

### If the Recommended XPS Engine Oil Is Not Available

Use a 4-stroke SAE 10W50 engine oil that meets or exceeds the following lubricant industry specifications.

Always check the API service label certification on the oil container. It must contain the indicated standards.

- API service classification SN and JASO MA2

### *Changing the Engine Oil*

The oil change should be carried out on a warm engine.

#### CAUTION

**Engine oil can be very hot. In order to avoid potential burns, do not remove the engine drain plug if the engine is hot. Wait until the engine oil is warm.**

1. Place the vehicle on a level surface. Apply the parking brake.
2. Clean the engine drain plug area.
3. Start the engine and let it idle for 2–3 minutes. Stop the engine.
4. Place a drain pan under the drain plug area.
5. Unscrew the drain plug.

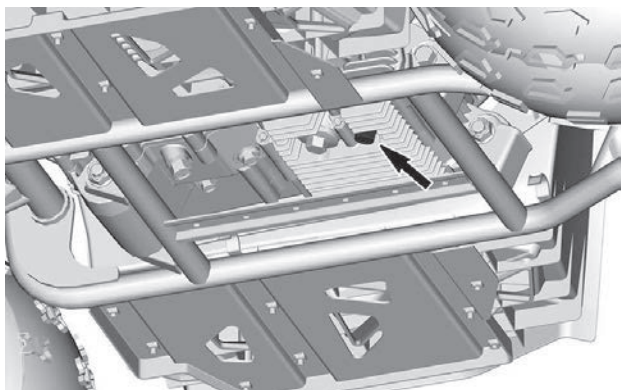
**UNDERNEATH THE ENGINE**

6. Allow sufficient time for all of the oil to flow out of the engine.
7. Clean the oil strainer screen with solvent and then allow it to dry.
8. Clean the drain plug.
9. Install a new sealing washer on the drain plug.
10. Reassemble the oil strainer screen and spring onto the drain plug.
11. Clean the sealing surface on the engine. Make sure it is free from burrs.
12. Reinstall the drain plug.
13. Tighten to specification.

<b>Tightening Torque</b>	
Drain plug	15 ± 1 Nm (133 ± 9 lbf-in)

14. Remove the dipstick.

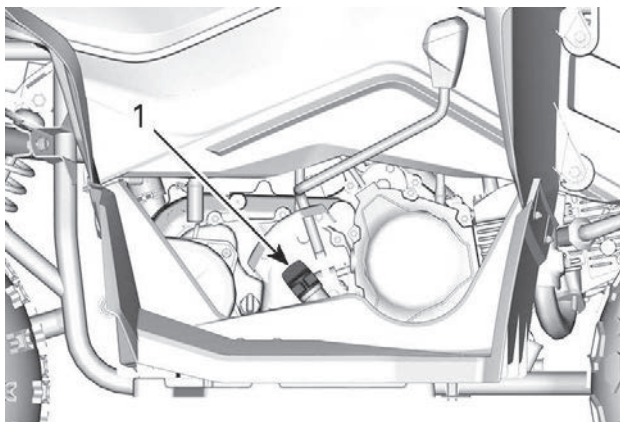

**RH SIDE OF ENGINE**

1. Dipstick

15. Refill the engine with recommended engine oil. Do not overfill. Refer to *Technical Specifications* for the capacity.
16. Reinstall the dipstick.
17. Start the engine and let it idle for a few minutes. Ensure that the drain plug area is not leaking.
18. Stop the engine. Wait a few minutes to allow the oil to flow down into the crankcase, then recheck the oil level. Adjust if necessary.
19. Dispose of used oil according to local environmental regulations.

**AIR FILTER**

***Air Filter Location***

The air filter housing is located under the seat.

***Removing the Air Filter***

1. Remove the seat.
2. Release the spring clips securing the cover of the air filter housing.

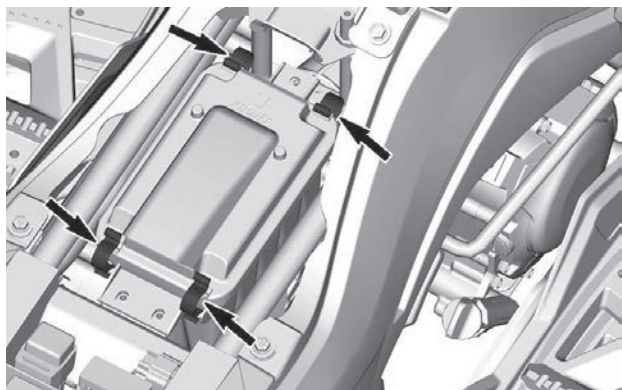
**AIR FILTER HOUSING COVER CLIPS**

3. Remove the cover.
4. Remove the air filter and support screen from the air filter housing.

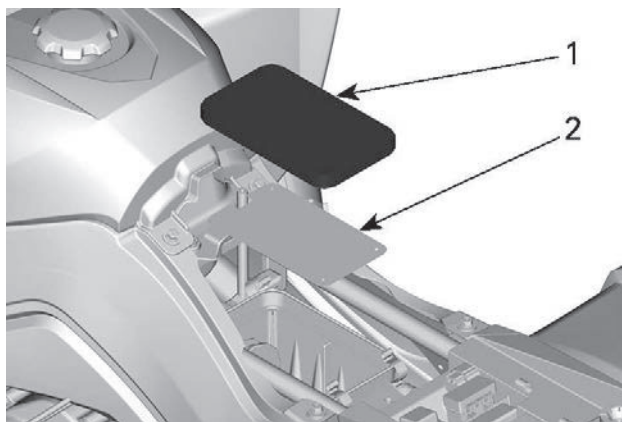
**INSIDE AIR FILTER HOUSING**

1. Air filter
2. Support screen

### **Cleaning and Lubricating the Air Filter**

1. Wash the filter with warm soapy water. Rinse and allow to dry. Replace if damaged.

## **NOTICE**

**Engine performance degradation or severe damage can occur if the air filter is not properly maintained and/or replaced.**

2. Apply a commercially available lubricant to the filter.
3. Remove any oil or debris from the air filter housing and the sediment drain.

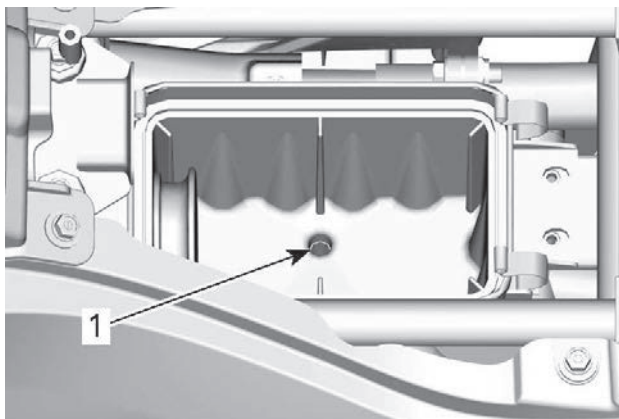

### **AIR FILTER HOUSING**

1. Sediment drain

### **Installing the Air Filter**

The installation is the reverse of the removal procedure.

1. Reinstall the support screen and air filter.
2. Position the cover on the air filter housing and lock the spring clips.
3. Reinstall the seat. Refer to *Installing the Seat*.



## AIR FILTER HOUSING

### *Draining the Air Filter Housing*

1. Periodically inspect the air filter housing drain tube for liquids or deposits.

### NOTICE

If the vehicle is operated in wet conditions or for extended periods at high throttle settings, inspect the drain tube more frequently than is specified in *Maintenance Schedule*.

2. If liquids or deposits are found, squeeze and remove the hose clamp. Remove the drain tube plug and empty it.

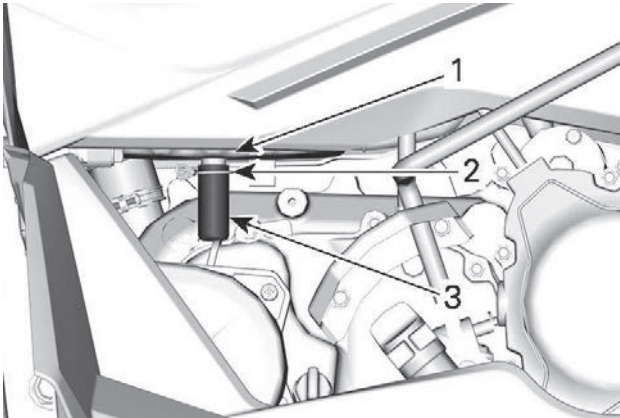

#### **RH SIDE OF VEHICLE**

1. Air filter housing
2. Hose clamp
3. Drain tube

### NOTICE

Do not start the engine if liquids/deposits are found in the drain tube.

3. Reinstall the drain tube on the housing. Secure it using the hose clamp.

- When liquids or deposits are found, the air filter and housing must be inspected, cleaned and dried. Replace the filter if necessary.

## Spark Arrester

### *Cleaning the Spark Arrester*

The muffler must be periodically purged of accumulated carbon.

**⚠ WARNING**

**Never perform this operation immediately after the engine has been run because exhaust system is very hot. Wear eye protection and gloves. Do not run the engine in an enclosed area. Respect all applicable laws and regulations.**

- Remove the spark arrester retaining screws.

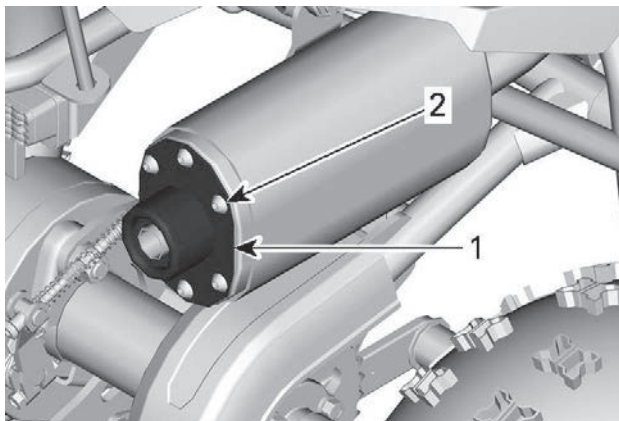

- Spark arrester*
- Retaining screws*

- Remove the spark arrester from the muffler.

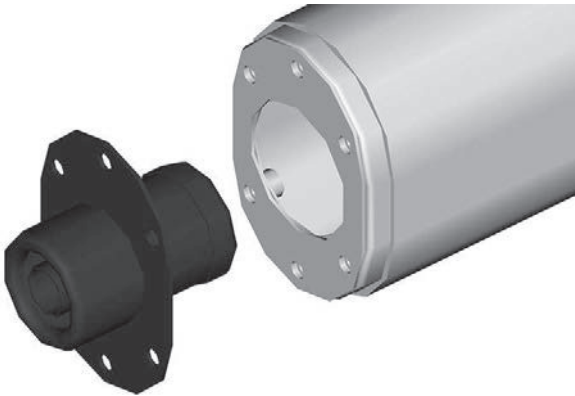
**SPARK ARRESTER**

3. Remove any carbon deposits from the spark arrester screen.

**NOTICE**

Use a soft (non-synthetic) brush and be careful to avoid damaging the spark arrester.

4. Inspect the screen for damage. Replace as necessary.
5. Reinstall the spark arrester in the muffler.
6. Tighten the screws to specification.

**Tightening Torque**

Spark arrester screws	10 ± 1 Nm (89 ± 9 lbf-in)
-----------------------	------------------------------

**Exhaust System**

1. Remove the RH side panel.
2. Inspect the exhaust system (muffler, exhaust pipe) for cracks, leaks or other damages.
3. Tighten the exhaust pipes screws attaching the pipe to the muffler to specifications.
4. Through the right front wheel arch, tighten the header nuts.

Tightening Torque	
Exhaust pipe screws	10 ± 1 Nm (89 ± 9 lbf-in)
Header nuts	

## CVT Cover

### *Draining the CVT Cover*

#### **NOTICE**

**Whenever you suspect that water has entered the CVT, drain the CVT cover immediately. The drain plug is located under the CVT cover.**

1. Remove the drain plug.

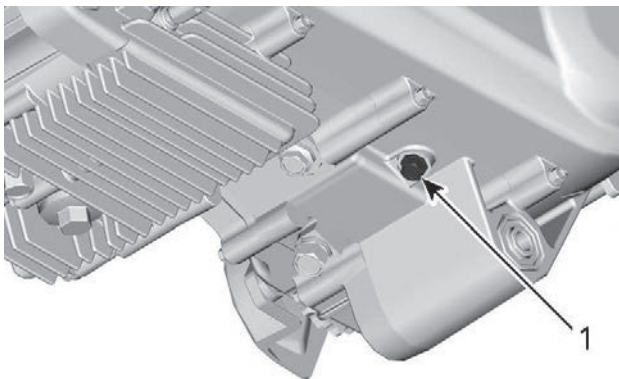

#### **UNDERSIDE OF VEHICLE**

1. *Drain plug*
2. Allow any water to drain from the cover.
3. Reinstall the drain plug.
4. Move the transmission lever to neutral (N).
5. Apply the parking brake.

6. Start the engine and vary the throttle for 10–15 seconds. This will dry the CVT internal components. Do not keep the throttle fully open for more than a few seconds.
7. Allow the engine to slow to idle speed.
8. Test for slippage of the CVT belt. If the belt slips, repeat the above steps.

## **NOTICE**

**Salt water will corrode metal components. If you operate the vehicle near salt water, rinse it frequently with fresh water.**

## **Gearbox Oil**

### *Recommended Gearbox Oil*

<b>XPS Recommended Gearbox Oil</b>
Premium mineral chaincase oil
<b>If the XPS Recommended Gearbox Oil Is Not Available</b>
Use a SAE 75W90 chaincase oil

## **NOTICE**

**Do not use other types of oil when servicing the gearbox.**

### *Verifying the Gearbox Oil Level*

There is no dipstick provided with this vehicle.

To ensure that the level is correct, oil should be visible at the bottom of the fill plug hole threads. The fill plug is located on the side of the gearbox, on the right side of the vehicle.

### *Changing the Gearbox Oil*

1. Place the vehicle on a level surface.
2. Clean the areas around the gearbox oil filler plug and drain plug. Remove the gearbox oil filler plug.

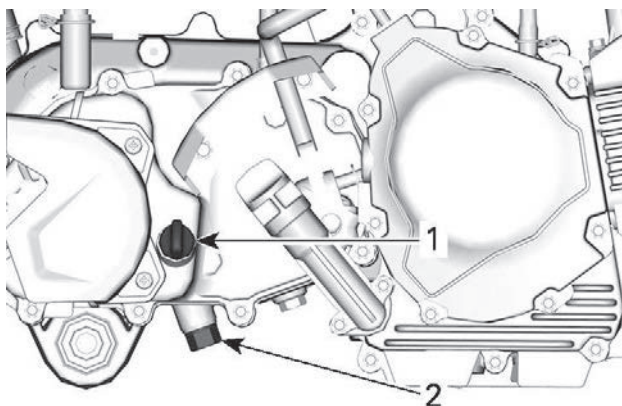

**RH SIDE OF ENGINE**

1. Filler plug
2. Drain plug

3. Place a drain pan under the gearbox.
4. Remove the drain plug and O-ring.
5. Allow enough time for oil to flow out of the gearbox.
6. Reinstall the drain plug with a new O-ring.
7. Tighten to specification.

<b>Tightening Torque</b>	
Drain plug	$19 \pm 2 \text{ Nm}$ $(168 \pm 18 \text{ lbf-in})$

8. Refill the gearbox with the recommended gearbox oil. Refer to *Technical Specifications* for the capacity.

**NOTICE**

**There is no dipstick provided with this vehicle to check the gearbox oil level. Ensure that the gearbox is completely drained before replenishing it with the specified amount of recommended oil.**

**NOTICE**

**Do not use other types of oil when servicing the gearbox.**

9. Reinstall the oil filler plug and inspect for leaks.
10. Dispose of used fluid according to local regulations.

## Throttle Cable

### *Inspecting the Throttle Cable*

1. Inspect throttle cable for excessive wear, kinking or fraying. Ensure that the cable moves freely.

### **NOTICE**

The throttle cable must be replaced if any signs of wear, fraying or other damages are found.

### *Lubricating the Throttle Cable*

1. Lubricate the throttle cable using a silicone-based cable lubricant.



### **WARNING**

Always use a silicone-based lubricant. Using another lubricant (such as a water-based lubricant) could cause the cable(s) to stick or become stiff,

### *Adjusting the Throttle Cable*

1. Check the throttle lever free play and adjust if necessary.

### **NOTE:**

If the correct adjustment is unattainable, see an authorized Can-Am Off-road dealer.

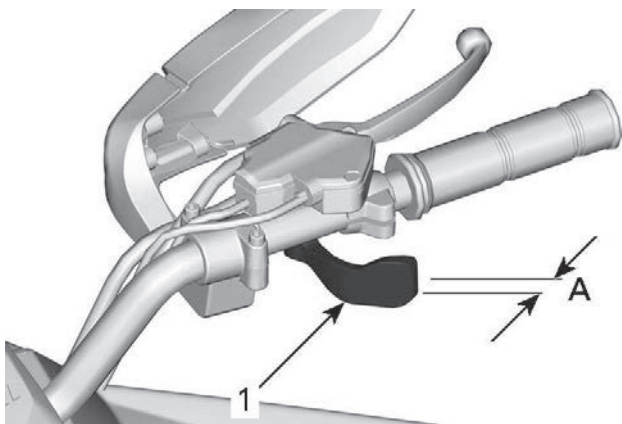

**THROTTLE LEVER**

1. Throttle lever

A. Free play

Throttle Free Play
1.5 to 3.2 mm (.063 to .125 in)

2. To adjust the cable, slide the rubber protector back to expose the throttle cable adjuster.



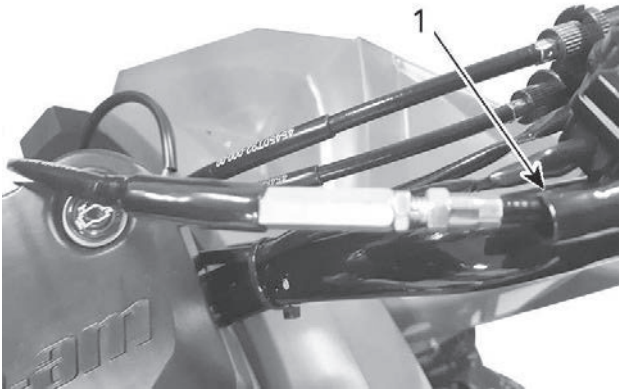

**THROTTLE CABLE**

1. *Rubber protector*
- 
3. Loosen the locknut and turn the adjuster to obtain the proper adjustment.
4. Measure the throttle free play at the tip of the throttle lever.
5. Tighten the locknut and reinstall the protector.

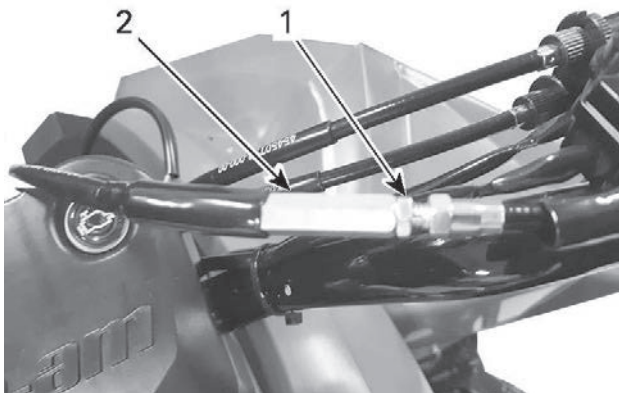

### **THROTTLE CABLE ADJUSTER**

1. Locknut
2. Adjuster

6. With the transmission lever set to NEUTRAL, start the engine.
7. Check if the throttle cable is adjusted correctly by turning the handlebar fully to the right, then fully to the left. If the engine RPM increases, readjust the throttle lever free play. Ensure that the throttle cable is properly routed and not binding on anything when the handlebar is turned.

## **Spark Plug**

### **Spark Plug Location**

The spark plug is located on the right side of the cylinder head.

### **Removing the Spark Plug**

1. Disconnect the spark plug cable from the spark plug.

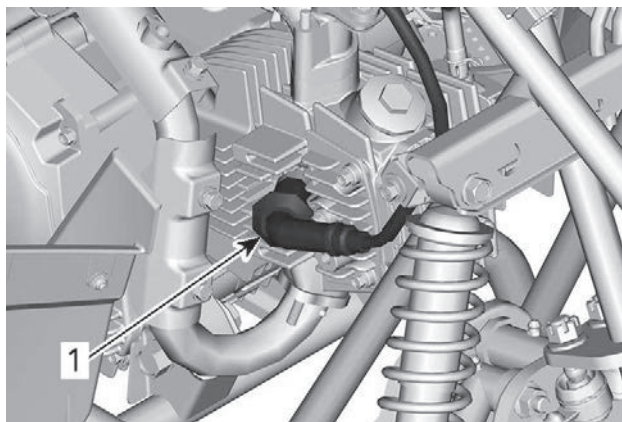

**RH SIDE OF ENGINE**

1. Spark plug cable

2. Unscrew the spark plug one turn.

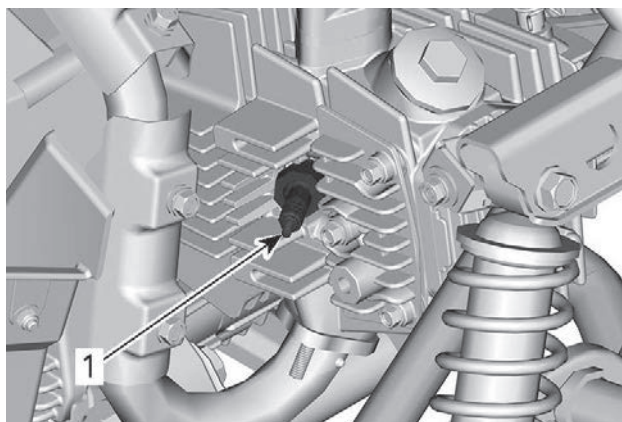

**RH SIDE OF ENGINE**

1. Spark plug

3. Clean the spark plug and cylinder head using pressurized air.

4. Remove the spark plug completely.

### **Installing the Spark Plug**

1. Prior to installation, ensure that the contact surfaces of the cylinder head and spark plug are clean.
2. Using a feeler gauge, set the spark plug gap between 0.6 to 0.7 mm (.024 to .028 in).
3. Apply lubricant to the spark plug threads.

<b>Anti-seize lubricant</b>
-----------------------------

4. Screw the spark plug into the cylinder head by hand. Then tighten it using a torque wrench and a spark plug socket.
5. Tighten to the specified torque.

<b>Tightening Torque</b>	
Spark plug	12 ± 1 Nm (106 ± 9 lbf-in)

## **Battery**

### **Battery Location**

The battery is located under the seat.

### **Battery Maintenance**

 <b>CAUTION</b>
---------------------------------------------------------------------------------------------------

<b>Never charge a battery while it is installed in the vehicle.</b>
---------------------------------------------------------------------

<b>NOTICE</b>
---------------

<b>Never remove the battery sealing cap.</b>
----------------------------------------------

These vehicles are equipped with a VRLA battery (Valve Regulated Lead Acid). It is a maintenance-free type battery, and there is no need to add water to adjust the electrolyte level.

### **Inspecting the Battery**

1. Inspect battery connections for tightness and cleanliness.
2. Inspect battery support.

### Removing the Battery

1. Disconnect the BLACK (-) cable first, then the RED (+) cable.

## NOTICE

Always respect this order for disassembly: Disconnect the BLACK (-) cable first.

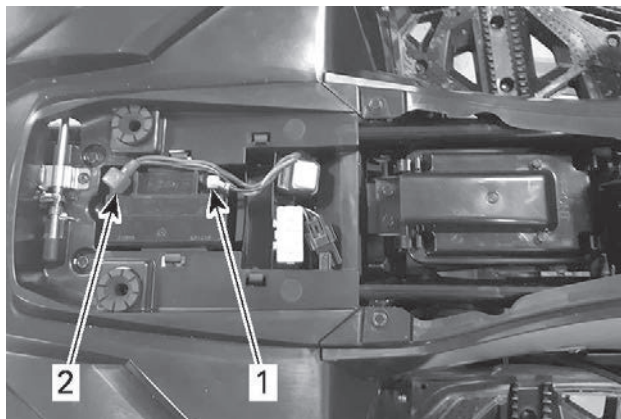

### BATTERY COMPARTMENT

1. BLACK (-)
2. RED (+)

2. Remove the battery from the vehicle.

### Cleaning the Battery

1. Clean battery, battery casing, cables and battery posts using a solution of baking soda and water.
2. Remove corrosion from battery cable terminals and battery posts using a firm wire brush. Battery top should be cleaned using a soft brush and any grease-cutting soap or baking soda solution.
3. Apply dielectric grease or an equivalent on battery posts to protect against oxidation.

### Installing the Battery

The installation is the reverse of the removal procedure.

## NOTICE

Always reconnect RED (+) cable first, then the BLACK (-) cable.

## Fuse

### *Fuse Box Location*

The fuse box is located under the seat.

### *Replacing a Fuse*

## NOTICE

Do not use a higher-rated fuse, as this can cause severe electrical system component damage.

1. If a fuse is open circuit (or burnt), replace it with a fuse of the same rating.
2. Open the fuse box cover and replace the fuse.

The fuse box is located in the battery compartment, just ahead of the battery.

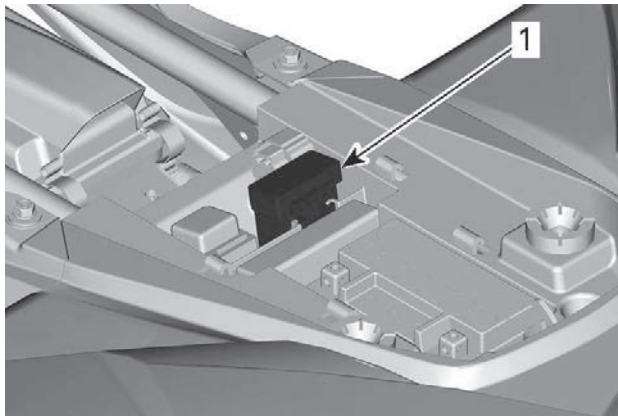

### **BATTERY COMPARTMENT**

1. Fuse box

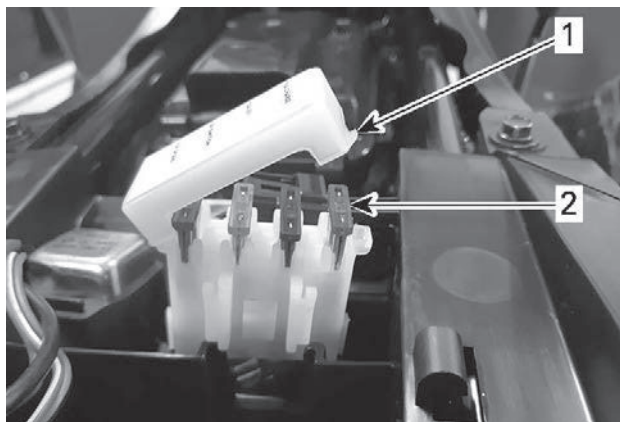

### **FUSE BOX**

1. Fuse box cover
2. Fuse

3. Ensure that the fuse box cover is closed securely.

## **Lights**

### **Replacing the Daytime Running Light Bulb**

 <b>CAUTION</b>
----------------------------------------------------------------------------------------------------

<b>Always turn the IGNITION switch to the OFF position before replacing a defective bulb.</b>
-----------------------------------------------------------------------------------------------

1. Disconnect the lights from the electrical harness.
2. Press the bulb holder inward, then rotate it counterclockwise one quarter turn to remove it from the housing.

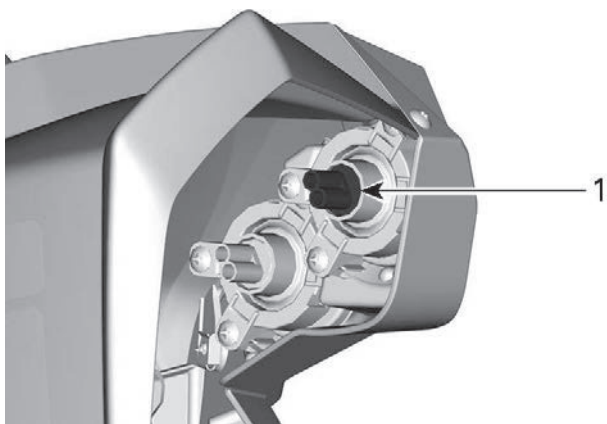

**FRONT RH WHEEL WELL**

1. *Bulb holder*

3. Note the position of the bulb, then carefully pull it out of the housing.

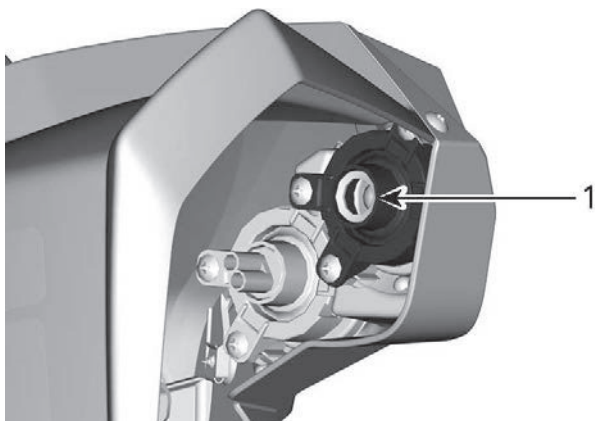

**LIGHT HOUSING**

1. *Bulb*



4. Apply dielectric grease to the new bulb contacts.
5. Insert the new bulb so that the filament is horizontal.
6. Press the bulb holder into the housing and rotate it clockwise one quarter turn.
7. Reconnect the lights to the harness.
8. Always check light operation after replacement. If the lights do not operate, see your authorized Can-Am Off-road dealer for service.

### **Taillight / Brake Light**

In the unlike event they do not work, have them checked by an authorized Can-Am Off-road dealer, repair shop or person of your choosing.

LED lights can not be replaced. In case of a malfunction, the tail light / brake light unit must be replaced.

## **Drive Chain, Roller and Sprockets**

### ***Inspecting the Drive Chain and the Sprockets***

#### **NOTICE**

**Replace chain and sprockets together to prevent rapid wear of these components.**

#### **NOTICE**

**Never operate this vehicle with the drive chain too loose or too tight as severe damage to the drive components can occur.**

### **Drive Chain**

1. Inspect the chain for damaged links or rollers.
2. Replace the chain if any damage is found.
3. Check the free play of the drive chain and adjust if necessary.

### **Roller**

1. Inspect the drive chain roller on the swing arm pivot member for excessive wear or damage. Replace if necessary.

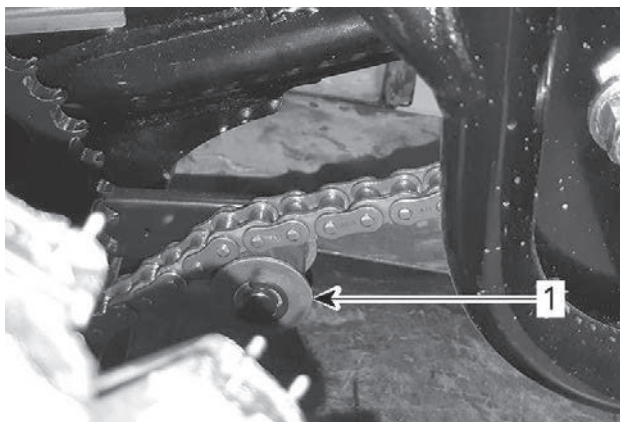

**RH REAR WHEEL WELL**

1. Drive chain roller

**Sprockets**

1. Check the sprocket axle and pinion for distortion, excessive wear or other damages. Replace if necessary.

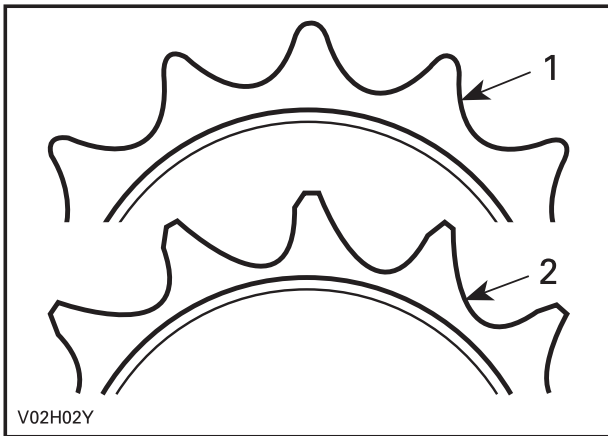

1. Good
2. Replace

### **Lubricating the Drive Chain**

The drive chain should be checked for proper lubrication before each ride.

1. Lubricate using commercial chain lubricant.

### **Verifying the Drive Chain Deflection**

1. Move the vehicle forward to create slack in the top part of the drive chain.
2. Collapse the suspension using an adjustable tie-down strap. Tie the strap between the axle and the rear bumper.
3. Tighten the strap until the rear axle is at the same level as the gear-box output shaft. This should tighten the top of the drive chain.
4. Pull the chain tensioner downward, away from the chain. Measure the deflection at the bottom of the chain. Adjust if necessary.

<b>Drive Chain Deflection</b>
6 to 12 mm (0.25 to 0.5 in)

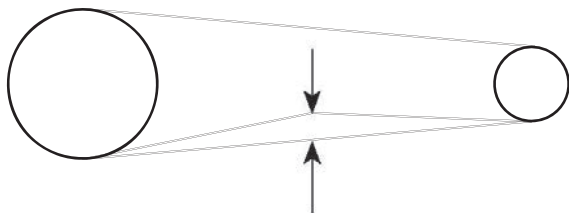

### ***Adjusting the Drive Chain***

The drive chain should be checked for proper adjustment before every ride.

#### ***NOTICE***

**Never adjust the drive chain with the driver seated on the vehicle. Remove any load on the vehicle.**

1. Place the vehicle on a level surface and set the transmission to neutral (N).
2. Check the drive chain condition.
3. Loosen the four drive axle locking bolts.
4. Loosen the chain adjuster locknut.

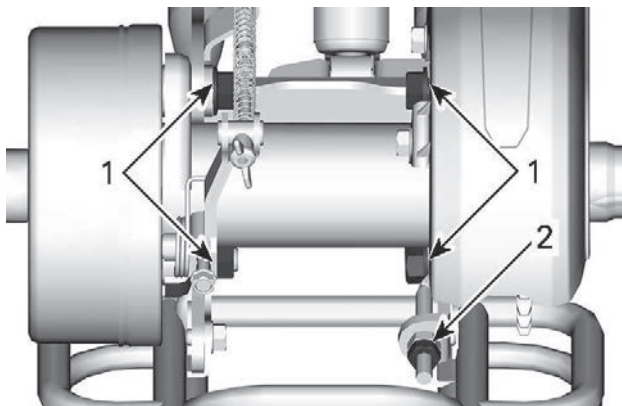

**REAR AXLE**

- 1. Locking bolts
- 2. Chain adjuster locknut

5. Turn the chain adjuster clockwise to obtain the required deflection.

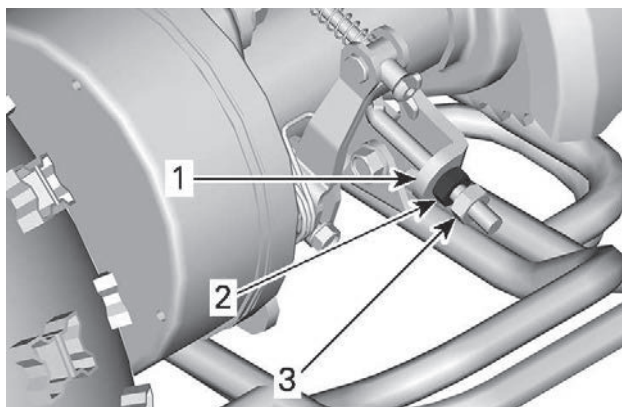

**REAR OF VEHICLE**

- 1. Chain adjuster
- 2. Chain adjuster nut
- 3. Chain adjuster locknut

- When properly adjusted, tighten the chain adjuster locknut to the specified torque.
- Tighten the drive axle locking bolts to the specified torque.

Tightening Torque	
Chain adjuster locknut	25 ± 3 Nm (18 ± 2 lbf-ft)
Drive axle locking bolts	60 ± 6 Nm (43 ± 4 lbf-ft)

## WHEEL BEARING

### *Inspecting the Wheel Bearing*

- Place vehicle on a level surface.
- Apply the parking brake.
- Lift and support vehicle.
- Secure vehicle on jack stands.
- Push and pull the wheels from the upper edge to feel the play.
- See an authorized Can-Am Off-road dealer if there is an abnormal play.



**TYPICAL**

## Tires and Wheels

### *Tire Pressure*

#### **⚠ WARNING**

**Tire pressure greatly affects vehicle handling and stability. Insufficient pressure may cause tire to deflate and rotate on wheel.**

**Overpressure may burst the tire. Always follow recommended pressure.**

**NEVER set tire pressure below minimum. It could cause the tire to dislodge from the rim.**

Check pressure when tires are **cold** before using the vehicle. Tire pressure changes with temperature and altitude. Recheck pressure if one of these conditions has changed.

Refer to the *Tire Pressure and Maximum Load* decal for proper tire pressure.

**NOTE:**

Although the tires are specifically designed for off-road use, a flat may still occur. Therefore, it is recommended to carry a tire gauge, tire pump and a repair kit.

***Tire Inspection***

Check tire for damage and wear. Replace if necessary.

 **WARNING**

**Do not rotate tires. The front and rear tires have a different size. The left and right tires have different unidirectional tread patterns.**

***Tire Replacement***

Tire replacement should be performed by an authorized Can-Am Off-road dealer, a repair shop or a person of your choosing.

 **WARNING**

**Replace tires only with the same type and size as original tires. For unidirectional tread pattern, ensure that the tires are installed in the correct direction of rotation. Tires should be replaced, by an experienced person, in accordance with tire industry standards and tools.**

***Removing the Wheel***

1. Place the vehicle on a level surface.
2. Stop the engine and apply the parking brake.
3. Slightly loosen the lug nuts.
4. Lift the side of the vehicle and place a support stand under the foot-rest frame.
5. Remove the lug nuts completely, then remove the wheel.

***Installing the Wheel***

1. Position the wheel on the hub.

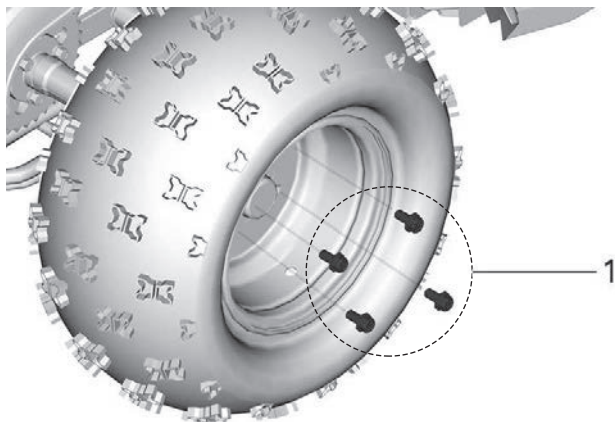

**TYPICAL**

1. Wheel lug bolts

**NOTE:**

Make sure the valve stem is facing outward. If the tires are unidirectional, be sure to install each wheel according to tire rotation (indicated by an arrow on the tire).

2. Install the wheel lug bolts finger tight.
3. Carefully remove the support stand and lower the vehicle to the ground.
4. Tighten the lug bolts in a crisscross pattern and then tighten to specification.

Tightening Torque	
Wheel lug bolt	30 ± 3 Nm (22 ± 2 lbf-ft)

**NOTICE**

Always use the recommended wheel lug bolts for the type of wheel.  
Using a different bolt could cause damage to the rim or hub.

## Steering System

### *Inspecting the Steering System*

1. Check the steering system for loose bolts or nuts.
2. If loose fasteners are found, see an authorized Can-Am Off-road dealer, repair shop or person of your choosing.

### *Toe Alignment*

1. Place vehicle on a level surface.
2. Check pressure in each tire. Adjust to recommended pressure.
3. Position and secure handlebar in the straight ahead position.
4. Place a rope around all four tires using an elastic, link both ends together.

#### **NOTE:**

The rope must be placed at the center of the wheels.

5. From the front of the front rim, pull on the rope so that it touched only the sides of the rear tire.

#### **NOTE:**

Ensure rope remains in this position as you carry out the following steps.

6. Measure the distance between the rope and the rim, at the front and at the rear of the wheel rim.
7. Repeat the measurement procedure on the other side.

The rear measurement should be 2 to 3 mm (1/16 to 1/8 in) more than the front measurement on each side of the vehicle to obtain the recommended toe out alignment,

Toe Out	
Total	3 to 6 mm (1/8 to 1/4 in)

8. See an authorized Can-Am Off-road dealer if the toe out is out of specification.

### *Lubricating the Front Knuckle*

#### *Renegade 70 and Renegade 110*

1. Lubricate the front knuckles. Each knuckle is equipped with a grease fitting.

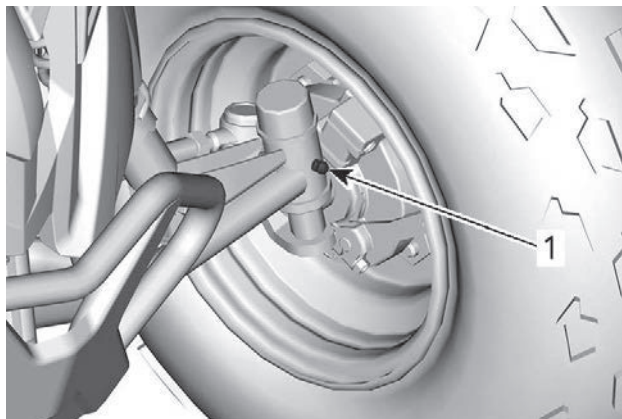
**XPS synthetic suspension grease****TYPICAL — INSIDE OF LH FRONT WHEEL**

1. Grease fitting

**Suspension*****Lubricating the Front Suspension***

1. Inspect the front suspension and ensure that all fasteners are tight.
2. Lubricate the front suspension arms pivots, especially after washing the vehicle or driving in water.

**XPS synthetic suspension grease**

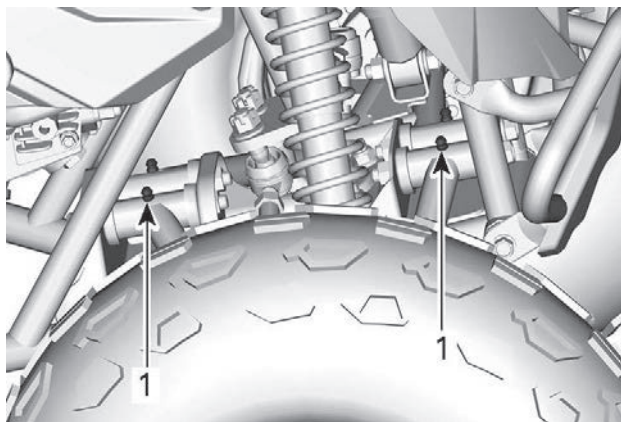

**TYPICAL — RH FRONT WHEEL WELL**

1. Grease fitting

## Brakes

### *Lubricating the Brake Cables*

1. Lubricate the brake cables using a silicone-based cable lubricant.

**⚠ WARNING**

**Always use a silicone-based lubricant. Using another lubricant (such as a water-based lubricant) could cause the cable(s) to stick or become stiff,**

### *Brake Free Play*

1. Check the free play of the front and rear brakes at the recommended maintenance schedule intervals.

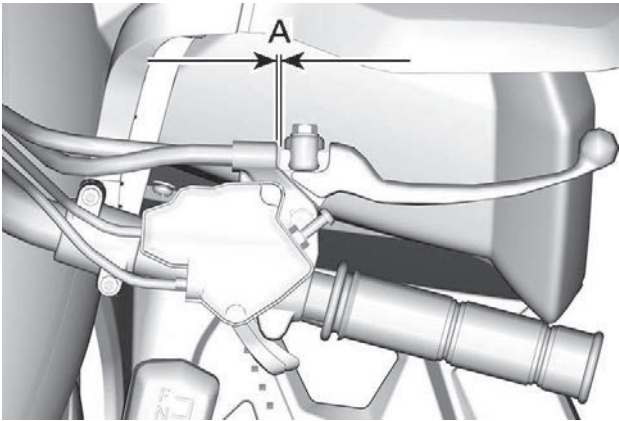
**TYPICAL — RH BRAKE LEVER**

A. 2 to 3 mm (.08 to .012 in)

2. If the free play is out of specification, adjust the front and rear brakes.
3. Always service the brakes when stopping ability is not sufficient.

**Front Brake Adjustment**

1. Place the vehicle on a level surface.
2. Move the transmission lever to neutral (N).
3. Lift the front of the vehicle until the front tires are just off the ground. Support the frame using a jack stand.
4. Manually rotate the left-front wheel as you tighten the top adjustment screw on the RH brake lever.

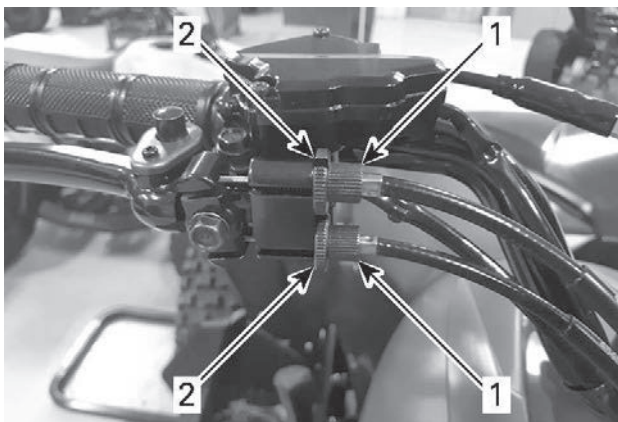

**TYPICAL — RH BRAKE LEVER (FRONT)**

1. Adjustment screws
2. Locknuts

5. When there is a slight drag on the wheel, loosen the adjustment screw one full turn.
6. Manually rotate the right-front wheel as you tighten the bottom adjustment screw on the RH brake lever.
7. When there is a slight drag on the wheel, loosen the adjustment screw one full turn.
8. Check that the RH brake lever works properly and that the free play is correct.
9. Tighten all locknuts.
10. Carefully remove the jack stand and lower the vehicle to the ground.

**Rear Brake Adjustment**

1. Place the vehicle on a level surface.
2. Move the transmission lever to neutral (N).
3. Lift the rear of vehicle until the rear tires are just off the ground. Support the frame using a jack stand.
4. Manually rotate the rear wheels as you tighten the adjuster on the rear brake drum.

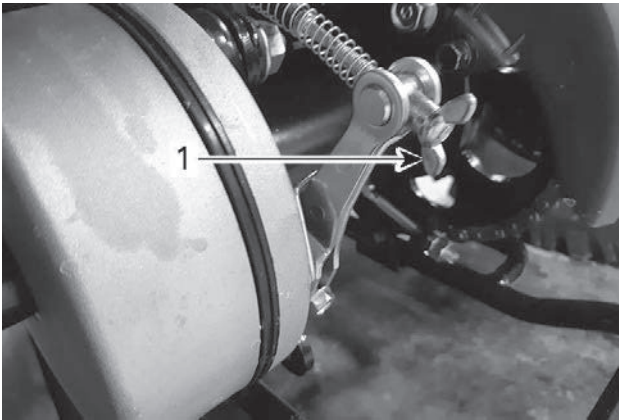
**REAR OF VEHICLE****1. Brake cable adjuster**

5. When there is a slight drag on the wheels, loosen the adjuster one full turn.
6. Verify that the LH brake lever works properly and that it comes back to its original position.
7. Check that the LH brake lever free play is correct.
8. Carefully remove the jack stand and lower the vehicle to the ground.

This page is intentionally blank



# **TECHNICAL INFORMATION**

---

## VEHICLE IDENTIFICATION

The main components of your vehicle (engine and frame) are identified using different serial numbers. It may sometimes become necessary to locate these numbers for warranty purposes or to trace your vehicle in the event of loss.

These numbers are also required by the authorized Can-Am Off-road dealer to complete warranty claims properly. We strongly recommend that you take note of all the serial numbers on your vehicle and supply them to your insurance company.

Record the identification numbers of the vehicle and the engine, and the key number.

Remove the spare key and store it in a safe place. The ignition key must be replaced if all keys are lost.

Vehicle Identification Number (VIN):	
Engine Identification Number (EIN):	
Key number	

## Vehicle Identification Number (VIN) Location

The VIN label is located under the rear fender, on the LH frame member.



## Engine Identification Number (EIN) Location

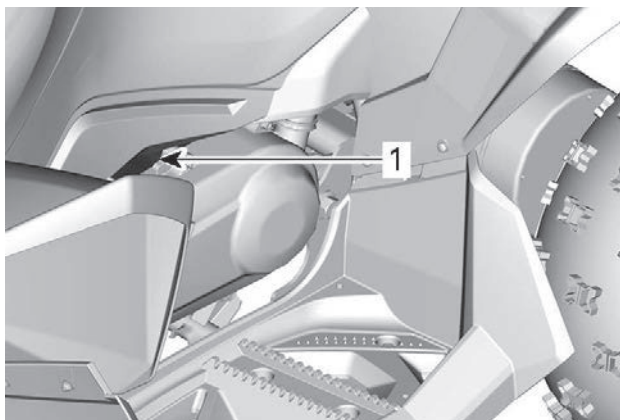

**LH SIDE OF VEHICLE**

1. EIN label

---

# COMPLIANCE HANG TAG

## Compliance Hang Tag

VEHICLE MODEL NAME:  
RENEGADE

ENGINE DESCRIPTION:  
XXX cc 4 STROKE

**EPA CERTIFIED**

NER (NORMALIZED EMISSION RATE) =   
ON 0 TO 10 SCALE, 0 BEING THE CLEANEST.

**BOMBARDIER RECREATIONAL PRODUCTS INC**  
**\*NO TO BE REMOVED PRIOR SALE.**



704909426

---

## COMPLIANCE LABELS

These labels indicate vehicles compliances.

### ANSI/SVIA Conformity

*Canadian and North American models*

Bombardier Recreational Products Inc. certifies that this ATV complies with ANSI / SVIA-1-2023 standard and is subject to an approved ATV Action Plan submitted by BRP and on file with the U.S. Consumer Product Safety Commission.

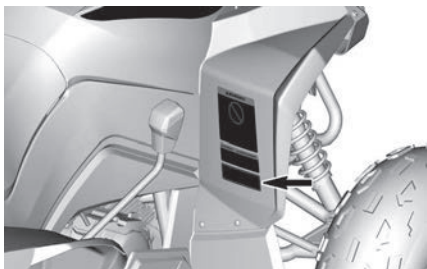

## Emission Control Information

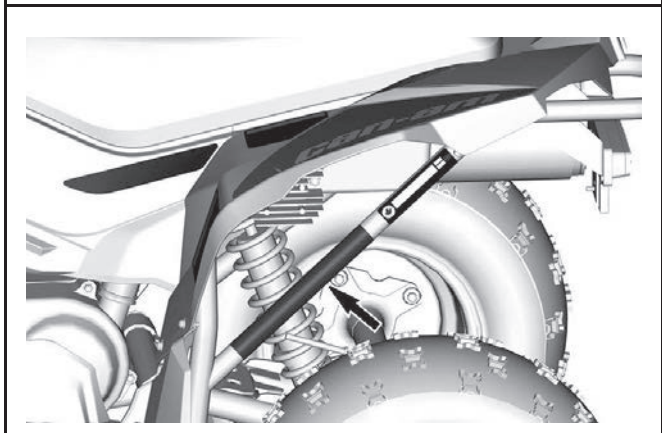

# US CPSC Conformity

## US CPSC Children's Product Certificate (CPC)



- 1 Product Description: [blurred]
- 2 Part: [blurred]
- 2 Comforms to: [blurred]
- 3 Importer or Manufacturer: [blurred]
- 4 Contact for Test Results: [blurred]
- 5 Mfg Date: [blurred] Mfg Place: [blurred]
- 6 Test Date: [blurred] Test Report #: [blurred]
- 7 Testing lab: [blurred]
- 8 Test Date: [blurred] Test Place: [blurred]
- 9 3rd Party Testing: [blurred]

704910536

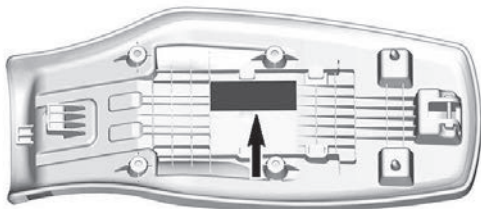



## Percentage of Ethanol

Models Outside of Canada and United States

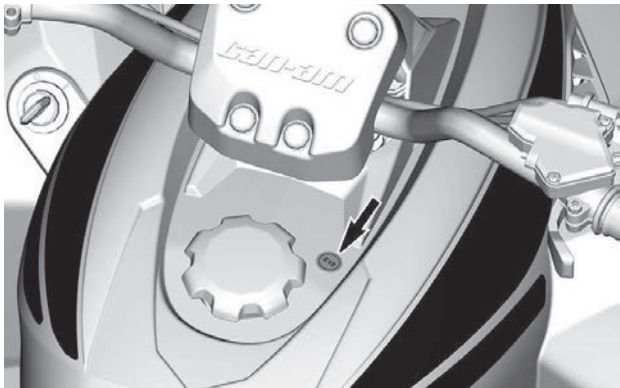

---

# EVAPORATIVE EMISSION CONTROL SYSTEM

## California Models with Evaporative Emission Control System

Vehicles labeled as meeting the CALIFORNIA EVAPORATIVE EMISSIONS REGULATIONS TIER III ALTERNATIVE STANDARD FOR ATV are equipped with an evaporative emission control system consisting of a low permeation fuel tank (LPFT) and low permeation fuel lines (LPFL).

The following statement is required by the CCR (California Code of Regulation): An add-on or modified part must be compliant with the applicable ARB evaporative emission control standards. A violation of this requirement is punishable by civil and/or criminal punishment.

---

# **NOISE EMISSION CONTROL SYSTEM REGULATION (CANADA/UNITED STATES)**

## **Tampering with a Noise Control System Is Prohibited!**

U.S. Federal law and Canadian provincial laws may prohibit the following acts or the causing there of:

1. The removal or rendering inoperative by any person other than for purposes of maintenance, repair or replacement of any device or element of design incorporated into any new vehicle for the purpose of noise control prior to its sale or delivery to the ultimate purchaser or while it is in use or,
2. The use of the vehicle after such device or element of design has been removed or rendered inoperative by any person.

## **Among the Acts Presumed to Constitute Tampering Are those Listed Below:**

1. Removal or alteration or the puncturing of the muffler or any engine component which conducts removal of engine exhaust gases.
2. Removal or alteration or the puncturing of any part of the intake system.
3. Replacing any moving parts of the vehicle or parts of the exhaust or intake system, with parts other than those specified by the manufacturer.
4. Lack of proper maintenance.

# EC DECLARATION OF CONFORMITY



565 de la Montagne Street  
Valcourt (Québec) J0E 2L0  
Canada  
www.brp.com

## EU Declaration of Conformity

**Authorized Representative:** BRP-Rotax GmbH Co. KG, Rotaxstrasse 1, Gunskirchen,  
A- 4623, Austria

This declaration of conformity is issued under the sole responsibility of the manufacturer.

The undersigned, representing the manufacturer, hereby declares that model year **2025 All Terrain Vehicles** marked with the **CE** mark and a 17-character vehicle identification number structured as **RF3xxxxxSxxxxxxx** or **RFGUxxxxSxxxxxxx** under commercial names **Can-Am Renegade** or **Can-Am DS** respectively comply with all the relevant provisions of the following Directives and Regulations:

Machinery Directive (MD) 2006/42/EC as amended up to and including Regulation (EU) 2019/1243	ISO 12100:2010 & EN 15997:2011
Non-Road Mobile Machinery (NRMM) Regulation (EU) 2016/1628 on gaseous pollutants as amended up to and including Regulation (EU) 2020/1040	
Electromagnetic Compatibility (EMC) Directive 2014/30/EU as amended up to and including Regulation (EU) 2018/1139	CISPR 12:2007/A1:2009 & IEC 61000-6-1:2016 or UN R10.04 or later version
Battery Directive 2006/66/EC as amended up to and including Directive (EU) 2018/849 and, Regulation (EU) 1103/2010 on battery capacity labelling	EN 50342-7:2015
Radio Equipment (RED) Directive 2014/53/EU as amended up to and including Regulation (EU) 2018/1139  (If fitted with radio frequency (RF) D.E.S.S. key)	Art. 3.1a: IEC 62368-1:2014 Art. 3.1b: CISPR 25:2016 & ISO 11452-2:2004  Art. 3.2: ETSI EN 300 330 V2.1.1.2017

Renald Plante, Eng.  
Director, Product Development, Can-Am ATV  
Bombardier Recreational Products Inc.

Valcourt, QC, Canada  
Jan 19, 2024

*SKI-DOO LYNX SEVADO EVRIDE ROTAX CAN-AM*

# UK DECLARATION OF CONFORMITY



565 de la Montagne Street  
Valcourt (Québec) J0E 2L0  
Canada  
www.brp.com

## UK Declaration of Conformity

**Authorized Representative:** BRP UK Ltd., (BWM Accountants Limited), Suite 5.1, 12  
Tithebarn Street, Liverpool, L2 2DT

This declaration of conformity is issued under the sole responsibility of the manufacturer.

The undersigned, representing the manufacturer, hereby declares that model year **2025 All Terrain Vehicles** marked with the <sup>UK</sup>CA mark and a 17-character vehicle identification number structured as **RF3xxxxxxSxxxxxxx** or **RFGUxxxxxSxxxxxxx** under commercial names **Can-Am Renegade** or **Can-Am DS** comply with all the relevant provisions of the following Statutory Instruments:

Supply of Machinery (Safety) Regulations 2008, UK SI 2008/1597 as amended up to and including SI 2020/1112	ISO 12100:2010 & EN 15997:2011
Non-Road Mobile Machinery (Type-Approval and Emission of Gaseous and Particulate Pollutants) Regulations 2018, UK SI 2018/764 as amended up to and including SI 2020/1393	
Electromagnetic Compatibility Regulations 2016, UK SI 2016/1091 as amended up to and including SI 2020/1112	CISPR 12:2007/A1:2009 & IEC 61000-6-1:2016 or UN R10.04 or later version
Batteries and Accumulators (Placing on the Market) Regulations 2008, UK SI 2008/2164 as amended up to and including UK SI 2020/904	EN 50342-7:2015
Radio Equipment Regulations 2017, UK SI 2017/1206 as amended up to and including SI 2020/1112  (If fitted with radio frequency (RF) D.E.S.S. key)	Art. 3.1a: IEC 62368-1:2014 Art. 3.1b: CISPR 25:2016 & ISO 11452-2:2004 Art. 3.2: ETSI EN 300 330 V2.1.1:2017

Renald Plante, Eng.  
Director, Product Development, Can-Am ATV  
Bombardier Recreational Products Inc.

Valcourt, QC, Canada  
Jan 19, 2024

SKI-DOO LYNX SEV-DOO EVRIDE ROTAX CAN-AM

This page is intentionally blank

# **TECHNICAL SPECIFICATIONS**

## TECHNICAL SPECIFICATIONS

Engine		
Type	4 stroke, EFI, air cooled, wet sump	
Number of cylinders	Single cylinder	
Displacement	111.7 cm <sup>3</sup> (6.8 in <sup>3</sup> )	
Number of valves	2	
Valve clearance	.06 mm (.002 in)	
Starting	Electric	
Engine oil	Recommended general purpose oil	XPS 10W50 Synthetic oil
	Recommended cold temperature oil	XPS 0W40 Synthetic oil
	Recommended warm temperature oil	XPS 10W50 Synthetic oil
	Alternate oil if XPS products are not available	Use a 4–stroke SAE 10W50 motor oil that meets the requirements for API service classification SN and JASO MA2.
	Capacity	Oil change with filter: 900 ml (0.95 qt (US))

Transmission	
Transmission	Continuously Variable Transmission (CVT)



<b>Gearbox</b>		
Type		3 positions: Forward, Neutral and Reverse
Gearbox oil	Type	Refer to <i>Recommended Gearbox Oil</i> in <i>Maintenance Procedures</i> section
	Capacity	350 ml (11.8 fl oz (US))

<b>Fuel System</b>		
Delivery type		Electronic Fuel Injection (EFI)
Idle speed		1,750 ± 150 RPM
Fuel	Type	Unleaded gasoline
	Octane	87 Pump-posted AKI (RON + MON)/2
Fuel tank	Capacity	6 l (1.6 gal (US))

<b>Electrical</b>		
Ignition type		Capacitor Discharge Ignition (CDI)
Spark plug	Make and type	NGK CR6HSA or equivalent
	Gap	0.6 to 0.7 mm (.024 to .028 in)
	Quantity	1

Electrical		
Battery	Type	Maintenance free
	Volt	12 volts, 4 A•h
Starting system		Electric start
Daytime running light bulb		4 x 6 W
Taillight and brake light		LED
Fuse	Charge	15 A
	EFI	10 A
	Ignition	5 A

Suspension			
Type	Front	110 Xxc	Arched double suspension arms
		All other	Single suspension arm
	Rear	Rigid axle, single shock	
Wheel Travel	Front	70	101 mm (4 in)
		110	127 mm (5 in)
		110 Xxc	140 mm (5.5 in)
	Rear	70	105 mm (4.1 in)
		110	147 mm (5.8 in)

Suspension			
		110 Xxc	149 mm (5.9 in)
Shock absorber	Front	110 Xxc	Piggyback gas
		All other	Oil
	Rear	110 Xxc	Gas
		All other	Oil

Tires			
Pressure	Front		Recommended tire inflation pressure is found on the <i>Tire Pressure and Maximum Load</i> label. Refer to appropriate <i>Important On-Product Labels</i> section for its location.
	Rear		
Size	Front	70	17 x 7-8, Duro HF-277
		110 110 Xxc	19 x 7-8, Duro HF-277
	Rear	70	17 x 8-8, Duro DI-2009
		110 110 Xxc	18 x 9.5-8, Duro DI-2009

<b>Wheels</b>		
Size	Front	Steel, 8 x 5.5
	Rear	Steel, 8 x 5.5
Wheel bolt torque		30 ± 3 Nm (22 ± 2 lbf-ft)

<b>Brakes</b>		
Front		Mechanical, 2 drums
Rear		Mechanical, 1 drum
RH brake lever		Front dual drums braking operation
LH brake lever		Rear drum braking operation
Parking device	70	On the RH brake lever
	110 110 Xxc	On the LH brake lever

<b>Weight and Dimensions</b>		
Dry weight	70 110	130 kg (287 lb)
	110 Xxc	135 kg (298 lb)
Overall length	70	149.5 cm (59 in)
	110 110 Xxc	154 cm (60.5 in)
Overall width	70	95.5 cm (37.6 in)

<b>Weight and Dimensions</b>		
	110	102.5 cm (40.4 in)
	110 Xxc	108 cm (42.5 in)
Overall height	70	93.5 cm (36.8 in)
	110 110 Xxc	97 cm (38.2 in)
Gross vehicle weight rating (GVWR)	70	215 kg (475 lb)
	110 110 Xxc	227 kg (500 lb)
Total vehicle load allowed	All	102 kg (180 lb)
Wheelbase	70	98.6 cm (38.8 in)
	110 110 Xxc	105 cm (41.3 in)
Ground clearance	70	90 mm (3.5 in)
	110 110 Xxc	114 mm (4.5 in)

This page is intentionally blank

# TROUBLESHOOT- ING

---

# TROUBLESHOOTING GUIDELINES

## Troubleshooting

### 1. ENGINE DOES NOT CRANK

#### **IGNITION SWITCH IS IN THE OFF POSITION.**

- *Place switch to the ON position.*

#### **BURNT FUSE.**

- *Check main supply fuse.*

#### **WEAK BATTERY OR LOOSE CONNECTIONS.**

- *Check connections and condition of terminals.*
- *Have the battery checked.*
- *Contact an authorized Can-Am Off-road dealer.*

### 2. ENGINE TURNS OVER BUT FAILS TO START

#### **EMERGENCY ENGINE STOP SWITCH IS IN THE OFF POSITION.**

- *Set switch to the ON position.*

#### **FLOODED ENGINE (SPARK PLUG WET WHEN REMOVED).**

- *When the engine does not start after several attempts, the engine may be flooded with fuel. Proceed as follows:*
  - *Turn ignition switch to ON and ensure choke is not applied.*
  - *Fully depress throttle lever and hold while starting the engine.*
  - *As soon as the engine starts, release throttle lever. Do not race engine.*
- ***If the engine still does not start:***
  - *Disconnect the spark plug cable.*
  - *Remove the spark plug.*
  - *Crank engine several times.*
- *Install new spark plug if possible or clean and dry removed spark plug.*
  - *Start engine as explained above. If engine continues to flood, seek service from an authorized Can-Am Off-road dealer, repair shop, or person of your own choosing for maintenance, repair, or replacement. Please refer to the US EPA Emissions-Related Warranty contained herein for information about warranty claims.*
- *Ensure there is no fuel in the engine oil due to engine flooding, if so, replace engine oil.*

#### **NO FUEL TO THE ENGINE (SPARK PLUG DRY WHEN REMOVED).**

- *Seek service from an authorized Can-Am dealer, repair shop, or person of your own choosing for maintenance, repair, or*



replacement. Please refer to the US EPA Emissions-Related Warranty contained herein for information about warranty claims.

## **SPARK PLUG/IGNITION (NO SPARK).**

- Remove spark plug from engine and reconnect it to spark plug cap.
- Ensure the ignition switch is set to ON, and the emergency engine stop switch is set to the RUN position.
- Start engine with spark plug grounded to the engine away from spark plug hole. If no spark appears, replace spark plug.
- If trouble persists, seek service from an authorized Can-Am dealer, repair shop, or person of your own choosing for maintenance, repair, or replacement. Please refer to the US EPA Emissions-Related Warranty contained herein for information about warranty claims.

## **3. ENGINE LACKS ACCELERATION OR POWER**

### **FOULED/DAMAGE/WORN SPARK PLUG.**

- Clean/verify spark plug and heat range. Replace as required.

### **LACK OF FUEL TO ENGINE.**

- Check items listed in Engine Turns Over But Fails To Start.

### **ENGINE IS OVERHEATING.**

- If the engine tends to overheat, try the following:
  - Reduce vehicle speed but maintain sufficient speed to supply cooling air to the engine. If engine is still overheating after approximately one minute, stop vehicle.
  - Apply parking brake and stop engine.
  - Let engine cool down.
  - See an authorized Can-Am Off-road dealer as soon as possible.
- If overheating persists, contact an authorized Can-Am Off-road dealer.

### **AIR FILTER/BOX CLOGGED OR DIRTY.**

- Check air filter and clean. If necessary replace air filter.
- Check the position of the air intake tube.

### **CVT DIRTY OR WORN, INCLUDING BELT.**

- Contact an authorized Can-Am Off-road dealer.

## **4. ENGINE BACKFIRE**

### **EXHAUST SYSTEM LEAKAGE.**

- Seek service from an authorized Can-Am Off-road dealer, repair shop, or person of your own choosing for maintenance, repair, or

*replacement. Please refer to the US EPA Emissions-Related Warranty contained herein for information about warranty claims.*

## **ENGINE IS RUNNING TOO HOT.**

- *See Engine Lacks Acceleration or Power.*

## **IGNITION TIMING IS INCORRECT OR THERE IS AN IGNITION SYSTEM FAILURE.**

- *Seek service from an authorized Can-Am Off-road dealer, repair shop, or person of your own choosing for maintenance, repair, or replacement. Please refer to the US EPA Emissions-Related Warranty contained herein for information about warranty claims.*

## **5. ENGINE MISFIRE**

### **FOULED/DAMAGED/WORN SPARK PLUG.**

- *Clean/verify spark plug and heat range. Replace as required.*

### **WATER IN FUEL.**

- *Drain fuel system and refill with fresh fuel.*

## **6. VEHICLE CANNOT REACH FULL SPEED**

### **ENGINE.**

- *See Engine Lacks Acceleration or Power.*

### **PARKING BRAKE.**

- *Ensure brake lever lock is completely disengaged.*

### **AIR FILTER/BOX CLOGGED OR DIRTY.**

- *Check air filter and clean. If necessary replace air filter.*
- *Check the position of the air intake tube.*

### **CVT DIRTY OR WORN, INCLUDING BELT.**

- *Contact an authorized Can-Am Off-road dealer.*

## **7. THE RPM INCREASES BUT THE VEHICLE DOES NOT MOVE**

### **THE TRANSMISSION IS IN NEUTRAL POSITION.**

- *Set transmission in REVERSE or FORWARD.*

### **CVT IS DEFECTIVE.**

- *Contact an authorized Can-Am Off-road dealer.*

## **WATER IN THE CVT HOUSING.**

- *Contact an authorized Can-Am Off-road dealer.*

This page is intentionally blank

# WARRANTY

---

# **BRP LIMITED WARRANTY CANADA AND USA: 2025 CAN-AM® YOUTH ATV**

## **1) Scope of the Limited Warranty**

Bombardier Recreational Products Inc. ("BRP") warrants its 2025 Can-Am Youth all terrain vehicles ("ATV") sold by authorized Can-Am ATV dealers (as hereinafter defined) in the United States of America ("USA") and in Canada from defects in material or workmanship for the period and under the conditions described below. This limited warranty will become null and void if:

1. The ATV was used for racing or any other competitive activity, at any point, even by a previous owner; or
2. The ATV has been altered or modified in such a way so as to adversely affect its operation, performance or durability, or has been altered or modified to change its intended use.

Non-factory installed parts and accessories are not covered under this limited warranty. Please refer to the applicable parts and accessories limited warranty text.

## **2) Limitations of Liability**

TO THE EXTEND PERMITTED BY LAW, THIS WARRANTY IS EXPRESSLY GIVEN AND ACCEPTED IN LIEU OF ANY AND ALL OTHER WARRANTIES, EXPRESSED OR IMPLIED, INCLUDING WITHOUT LIMITATION ANY WARRANTY OF MERCHANTABILITY OR FITNESS FOR A PARTICULAR PURPOSE. TO THE EXTENT THAT THEY CANNOT BE DISCLAIMED, THE IMPLIED WARRANTIES ARE LIMITED IN DURATION TO THE LIFE OF THE EXPRESS WARRANTY. INCIDENTAL AND CONSEQUENTIAL DAMAGES ARE EXCLUDED FROM COVERAGE UNDER THIS WARRANTY. SOME STATES/PROVINCES DO NOT ALLOW FOR THE DISCLAIMERS, LIMITATIONS AND EXCLUSIONS IDENTIFIED ABOVE. AS A RESULT, THEY MAY NOT APPLY TO YOU. THIS WARRANTY GIVES YOU SPECIFIC RIGHTS, AND YOU MAY ALSO HAVE OTHER LEGAL RIGHTS WHICH MAY VARY FROM STATE TO STATE, OR PROVINCE TO PROVINCE.

Neither the distributor, any BRP dealer nor any other person has been authorized to make any affirmation, representation or warranty regarding the product, other than those contained in this limited warranty, and if made, shall not be enforceable against BRP.

BRP reserves the right to modify this limited warranty at any time, being understood that such modification will not alter the warranty conditions applicable to the products sold while this warranty is in effect.

## **3) Exclusions – ARE NOT Warranted**

The following are not warranted under any circumstances:

- Normal wear and tear;

- Routine maintenance items, tune ups, adjustments;
- Damage caused by failure to provide proper maintenance and/or storage, as described in this Can-Am Youth ATV Operator's Guide;
- Damage resulting from removal of parts, improper repairs, service, maintenance, modifications or use of parts not manufactured or approved by BRP or resulting from repairs done by a person that is not an authorized servicing Can-Am ATV dealer;
- Damage caused by abuse, abnormal use, neglect or operation of the product in a manner inconsistent with the recommended operation described in this Can-Am Youth ATV Operator's Guide;
- Damage resulting from accident, submersion, fire, theft, vandalism or any act of God;
- Operation with fuels, oils or lubricants which are not suitable for use with the product (see in this Can-Am Youth ATV Operator's Guide);
- Damages from rust, corrosion or exposure to the elements;
- Damage resulting from water or snow ingestion;
- Incidental or consequential damages, or damages of any kind including without limitation towing, storage, telephone, rental, taxi, inconvenience, insurance coverage, loan payments, loss of time, loss of income.

#### 4) Warranty Coverage Period

This limited warranty will be in effect from (1) the date of delivery to the first retail consumer or (2) the date the product is first put into use, whichever occurs first and for the applicable period below:

- SIX (6) CONSECUTIVE MONTHS, for private use or commercial use owners.
- For emission-related components; please also refer to the *US EPA Emission-Related Warranty* contained herein.
- For evaporative emission-related components of California models equipped with evaporative emission control system produced by BRP for sale in the State of California that are originally sold to a resident or subsequently warranty registered to a resident in the State of California, please also refer to the *California Evaporative Emissions Control Warranty Statement* contained herein.

The repair or replacement of parts or the performance of service under this warranty does not extend the life of this warranty beyond its original expiration date.

#### 5) Conditions to Have Warranty Coverage

This warranty coverage is available only if each of the following conditions has been fulfilled:

- The 2025 Can-Am Youth ATV must be purchased as new and unused by its first owner from a Can-Am ATV dealer authorized to

distribute Can-Am ATVs in the country in which the sale occurred (“Can-Am ATV dealer”);

- The BRP specified pre-delivery inspection process must be completed and documented and signed by the purchaser;
- The 2025 Can-Am Youth ATV must have undergone proper registration by an authorized Can-Am ATV dealer;
- The 2025 Can-Am Youth ATV must be purchased in the country in which the purchaser resides;
- Routine maintenance outlined in the Operator’s Guide must be timely performed in order to maintain warranty coverage. BRP reserves the right to make warranty coverage contingent upon proof of proper maintenance.

BRP will not honor this limited warranty to any private use owner or commercial use owner if one of the preceding conditions has not been met. Such limitations are necessary in order to allow BRP to preserve both the safety of its products, and also that of its consumers and the general public.

## **6) What to Do to Obtain Warranty Coverage**

The customer must cease using the Can-Am ATV upon the appearance of an anomaly.

The customer must notify a servicing BRP dealer within three (3) days of the appearance of a defect, and provide it with reasonable access to the product and reasonable opportunity to repair it.

The customer must also present to the authorized BRP dealer, proof of purchase of the product and must sign the repair/work order prior to starting the repair in order to validate the warranty repair.

All parts replaced under this limited warranty become the property of BRP.

## **7) What BRP Will Do**

BRP’s obligations under this warranty are limited to, at its sole discretion, repairing parts found defective under normal use, maintenance and service, or replacing such parts with new genuine Can-Am ATV parts without charge for parts and labor, at any authorized BRP dealer during the warranty coverage period under the conditions described herein. No claim of breach of warranty shall be cause for cancellation or rescission of the sale of the Can-Am ATV to the owner.

In the event that service is required outside of the country of original sale, the owner will bear responsibility for any additional charges due to local practices and conditions, such as, but not limited to, freight, insurance, taxes, license fees, import duties, and any and all other financial charges, including those levied by governments, states, territories and their respective agencies.



BRP reserves the right to improve or modify products from time to time without assuming any obligation to modify products previously manufactured.

## 8) Transfer

If the ownership of a product is transferred during the warranty coverage period, this limited warranty, subject to its terms and conditions, shall also be transferred and be valid for the remaining coverage period provided BRP or an authorized Can-Am ATV Distributor/Dealer receives a proof that the former owner agreed to the transfer of ownership, in addition to the coordinates of the new owner.

## 9) Consumer Assistance

In the event of a controversy or a dispute in connection with this limited warranty, BRP suggests that you try to resolve the issue at the dealership level. We recommend discussing the issue with the authorized dealer's service manager or owner.

If the matter still remains unresolved, contact BRP by filling out the customer contact form at **www.brp.com** or contact BRP by mail at one of the addresses listed under the *Contact Us* section of this guide.

---

## US EPA EMISSION – RELATED WARRANTY

Bombardier Recreational Products Inc. (“BRP”) warrants to the ultimate purchaser and each subsequent purchaser that this new vehicle, including all parts of its exhaust emission control system and its evaporative emission control system, meets two conditions:

1. It is designed, built, and equipped so it conforms at the time of sale to the ultimate purchaser with the requirements of 40 CFR 1051 and 40 CFR 1060.
2. It is free from defects in materials and workmanship that may keep it from meeting the requirements of 40 CFR 1051 and 40 CFR 1060.

Where a warrantable condition exists, BRP will repair or replace, as it elects, any part or component with a defect in materials or workmanship that would increase the engine's emissions of any regulated pollutant within the stated warranty period at no cost to the owner, including expenses related to diagnosing and repairing or replacing emission-related parts. All defective parts replaced under this warranty become the property of BRP.

For all emission-related warranty claims, BRP is limiting the diagnosis and repair of emission-related parts to the authorized Can-Am dealers, unless for emergency repairs as required by item 2 of the following list.

As a certifying manufacturer, BRP will not deny emission-related warranty claims based on any of the following:

1. Maintenance or other service BRP or BRP's authorized facilities performed.
2. Engine/equipment repair work that an operator performed to correct an unsafe, emergency condition attributable to BRP as long as the operator tries to restore the engine/equipment to its proper configuration as soon as possible.
3. Any action or inaction by the operator unrelated to the warranty claim.
4. Maintenance that was performed more frequently than BRP specify.
5. Anything that is BRP fault or responsibility.
6. The use of any fuel that is commonly available where the equipment operates unless BRP written maintenance instructions state that this fuel would harm the equipment's emission control system and operators can readily find the proper fuel. See maintenance information section and fuel requirements of fueling section.

### Emission-Related Warranty Period

The emission-related warranty is valid for the following period whichever comes first:

	Hours	Months	Kilometers
Exhaust emission-related components	500	30	5000
Evaporative emission-related components	N/A	24	N/A

## Components Covered

The emission-related warranty covers all components whose failure would increase an engine's emissions of any regulated pollutant, including the following listed components:

1. For exhaust emissions, emission-related components include any engine parts related to the following systems:
  - Air-induction system
  - Fuel system
  - Ignition system
  - Exhaust gas recirculation systems.
2. The following parts are also considered emission-related components for exhaust emissions:
  - After treatment devices
  - Crankcase ventilation valves
  - Sensors
  - Electronic control units.
3. The following parts are considered emission-related components for evaporative emissions:
  - Fuel tank
  - Fuel cap
  - Fuel line
  - Fuel line fittings
  - Clamps\*
  - Pressure relief valves\*
  - Control valves\*
  - Control solenoids\*
  - Electronic controls\*
  - Vacuum control diaphragms\*
  - Control cables\*
  - Control linkages\*
  - Purge valves
  - Vapor hoses
  - Liquid/vapor separator
  - Carbon canister
  - Canister mounting brackets

- Carburetor purge port connector.

**NOTE:** \*As related to the evaporative emission control system.

4. Emission-related components also include any other part whose only purpose is to reduce emissions or whose failure will increase emissions without significantly degrading engine/equipment performance.

### **Limited Applicability**

As a certifying manufacturer, BRP may deny emission-related warranty claims for failures that have been caused by the owner's or operator's improper maintenance or use, by accidents for which the manufacturer has no responsibility, or by acts of God. For example, an emission-related warranty claim need not be honored for failures that have been directly caused by the operator's abuse of the engine/equipment or the operator's use of the engine/equipment in a manner for which it was not designed and are not attributable to the manufacturer in anyway.

If you have any question regarding your warranty rights and responsibility or for the name and location of the nearest authorized BRP dealer, you should contact BRP by filling out the customer contact form at **www.brp.com** or contact BRP by mail at one of the addresses listed under the *Contact Us* section of this guide, or call at 1-888-272-9222.

---

# CALIFORNIA EVAPORATIVE EMISSIONS CONTROL WARRANTY STATEMENT

The warranty periods begin on the date the new Off-Highway Recreational Vehicle ("OHRV") is delivered to an ultimate purchaser.

Bombardier Recreational Products Inc. ("BRP") warrants to the ultimate purchaser and each subsequent purchaser that the OHRV is:

1. Designed, built, and equipped so as to conform, at the time of sale, with all applicable laws, rules and regulations; and
2. Free from defects in materials and workmanship that may cause the failure of a warranted part. All replacement parts must be identical in all material respects to that part as described in BRP's Executive Order of Certification application.

The warranty on emissions-related parts function as follows:

1. Repair or replacement of any warranted part must be performed at no charge to the OHRV owner, at a warranty station, except in the case of a temporary repair when a warranted part or a warranty station is not reasonably available to the OHRV owner. In the event a temporary repair is permitted, repairs may be performed at any available service establishment, or by the owner, using any replacement part. BRP must reimburse the owner for his or her expenses including diagnostic charges for such temporary repair or replacement, not to exceed BRP's suggested retail price for all warranted parts replaced and labor charges based on BRP's recommended time allowance for the warranty repair and the geographically appropriate hourly labor rate.
2. The lack of availability of warranted parts or the incompleteness of repairs within a reasonable time period, not to exceed 30 days from the time the OHRV is initially presented to the warranty station for repair, will qualify the need for a temporary repair.
3. Any warranted part which is not scheduled for replacement as part of maintenance in the written instructions must be warranted for the warranty period defined below. If any such part fails during the warranty period, it must be repaired or replaced by BRP. Any such part repaired or replaced under warranty must be fully warranted.
4. Any warranted part which is scheduled only for regular inspection in the written instructions must be warranted for the warranty period defined below. A statement in such written instructions to the effect of "repair or replace as necessary" does not reduce the period of warranty coverage. Any such part repaired or replaced under warranty is warranted for the remaining warranty period.
5. Any warranted part which is scheduled for replacement as part of maintenance in the written instructions is warranted for the period of time prior to the first scheduled replacement point for that part. If the part fails before the first scheduled replacement point, the part will be repaired or replaced by BRP. Any such part repaired or replaced under warranty is warranted for the remainder of the period prior to the first scheduled replacement point for the part.

6. Warranty services or repairs are provided at all manufacturer dealerships that are owned by the manufacturer or franchised to service the subject OHRVs.
7. The OHRV owner will not be charged for diagnostic labor which leads to the determination that a warranted part is, in fact, defective, provided that such diagnostic work is performed at a warranty station.
8. BRP is liable for damages to other vehicle components proximately caused by a failure, under warranty, of any warranted part.
9. Any replacement part designated by BRP may be used in warranty repairs provided without charge to the OHRV owner. Such use will not reduce the warranty obligations of BRP, except that BRP will not be liable for repair or replacement of any replacement part which is not a warranted part.
10. Any add-on or modified part exempted by the Air Resources Board from the prohibitions of section 27156 of the California Vehicle Code may be used on an OHRV. Such use, in and of itself, will not be grounds for disallowing a warranty claim. BRP is not liable to warrant failures of warranted parts caused by the use of an add-on or modified part(s) unless such part(s) are also warranted.

Conditions and exclusions:

- BRP may deny you warranty coverage if your OHRV or a part has failed directly due to abuse, neglect, improper maintenance or unapproved modifications.

## **Your Warranty Rights And Obligations**

The California Air Resources Board is pleased to explain the evaporative emissions control system warranty on your 2025 All-Terrain Vehicle. In California, new off-highway recreational vehicles must be designed, built, and equipped to meet the State's stringent anti-smog standards. BRP must warrant the evaporative emissions control system on your All-Terrain Vehicle for the periods of time listed below provided there has been no abuse, neglect, improper maintenance, or unapproved modification of your All-Terrain Vehicle.

Your evaporative emissions control system may include parts such as the carburetor or fuel-injection system, fuel tank, fuel hoses, carbon canister, and engine computer. Also included may be hoses, belts, connectors and other evaporative emissions-related assemblies. Where a warrantable condition exists, Bombardier Recreational Products Inc. will repair your All-Terrain Vehicle at no cost to you including diagnosis, parts and labor.

## **OHRV Manufacturer's Warranty Coverage**

The warranty period for this OHRV is 60 months, or 5000 miles, or 500 hours, whichever comes first.

Parts covered:

1. Canister Mounting Bracket(s)
2. Carbon Canister
3. Purge Port Connector
4. Clamp(s)\*
5. Electronic Control\*
6. Fuel Cap
7. Filler Neck
8. Filler Neck Hose
9. Fuel Line(s)
10. Fuel Line Fitting(s)
11. Fuel Tank
12. Pressure Relief Valve(s)\*
13. Purge Valve(s)
14. Check Valve(s)\*
15. Vapor Hose(s)
16. Flow Reducer
17. Filter(s)\*
18. Fuel pump
19. All other parts not listed that may affect the evaporative emissions control system

**NOTE:**

\*As related to the evaporative emission control system.

If any evaporative emissions-related part on your All-Terrain Vehicle is defective the part will be repaired or replaced by Bombardier Recreational Products Inc.

## Owner's Warranty Responsibilities

As the All-Terrain Vehicle owner, you are responsible for the performance of the required maintenance listed in your owner's manual. Bombardier Recreational Products Inc. recommends that you retain all receipts covering maintenance on your All-Terrain Vehicle, but Bombardier Recreational Products Inc. cannot deny warranty solely for the lack of receipts or for failure to ensure the performance of a scheduled maintenance.

As an owner you are responsible for presenting your All-Terrain Vehicle to a Bombardier Recreational Products Inc. dealer as soon as a problem exists. The warranty repairs should be completed in a reasonable time, not to exceed 30 days.

As an All-Terrain Vehicle owner, you should also be aware that Bombardier Recreational Products Inc. may deny you warranty coverage if your All-Terrain Vehicle or a part has failed due to abuse, neglect, improper maintenance or unapproved modifications.

---

*CALIFORNIA EVAPORATIVE EMISSIONS CONTROL WARRANTY  
STATEMENT*

If you have any questions regarding your warranty rights and responsibilities, you should contact:

- Bombardier Recreational Products Inc. at 1-888-272-9222 or,
- The California Air Resources Board at 4001 Iowa Avenue, Riverside, CA 92507.



---

# **BRP INTERNATIONAL LIMITED WARRANTY: 2025 CAN-AM® YOUTH ATV**

## **1) Scope of the Limited Warranty**

Bombardier Recreational Products Inc. ("BRP") warrants its 2025 Can-Am Youth ATV sold by Can-Am ATV distributors or dealers authorized by BRP to distribute Can-Am ATVs ("Can-Am ATV Distributor/Dealer") outside of the United States of America ("USA"), Canada, member states of the European Economic Area (which is comprised of the member states of the European Union plus the United Kingdom, Norway, Iceland and Liechtenstein) ("EEA"), member states of the Commonwealth of the Independent States (including Ukraine and Turkmenistan but not Russia) ("CIS"), Russia and Turkey, from defects in material or workmanship for the period and under the conditions described below.

Non-factory installed parts and accessories are not covered under this limited warranty. Please refer to the applicable parts and accessories limited warranty text.

This limited warranty will become null and void if:

1. The ATV was used for racing or any other competitive activity, at any point, even by a previous owner; or
2. The ATV has been altered or modified in such a way so as to adversely affect its operation, performance or durability, or has been altered or modified to change its intended use.

## **2) Limitations of Liability**

TO THE EXTENT PERMITTED BY LAW, THIS WARRANTY IS EXPRESSLY GIVEN AND ACCEPTED IN LIEU OF ANY AND ALL OTHER WARRANTIES, EXPRESSED OR IMPLIED, INCLUDING WITHOUT LIMITATION ANY WARRANTY OF MERCHANTABILITY OR FITNESS FOR A PARTICULAR PURPOSE. TO THE EXTENT THAT THEY CANNOT BE DISCLAIMED, THE IMPLIED WARRANTIES ARE LIMITED IN DURATION TO THE LIFE OF THE EXPRESS WARRANTY. INCIDENTAL AND CONSEQUENTIAL DAMAGES ARE EXCLUDED FROM COVERAGE UNDER THIS WARRANTY. SOME JURISDICTIONS DO NOT ALLOW FOR THE DISCLAIMERS, LIMITATIONS AND EXCLUSIONS IDENTIFIED ABOVE. AS A RESULT, THEY MAY NOT APPLY TO YOU. THIS WARRANTY GIVES YOU SPECIFIC RIGHTS AND YOU MAY ALSO HAVE OTHER LEGAL RIGHTS WHICH MAY VARY FROM COUNTRY TO COUNTRY. (FOR PRODUCTS PURCHASED IN AUSTRALIA SEE THE WARRANTY COVERAGE PERIOD SECTION BELOW).

Neither the Can-Am ATV Distributor/Dealer nor any other person has been authorized to make any affirmation, representation or warranty regarding the product, other than those contained in this limited warranty, and if made, shall not be enforceable against BRP.

BRP reserves the right to modify this warranty at any time, being understood that such modification will not alter the warranty conditions applicable to the products sold while this warranty is in effect.

### **3) Exclusions – Are NOT Warranted**

The following are not warranted under any circumstances:

- Normal wear and tear;
- Routine maintenance items, tune ups, adjustments;
- Damage caused by failure to provide proper maintenance and/or storage, as described in this Can-Am Youth ATV Operator's Guide;
- Damage resulting from removal of parts, improper repairs, service, maintenance, modifications or use of parts not manufactured or approved by BRP or resulting from repairs done by a person that is not an authorized servicing Can-Am ATV dealer;
- Damage caused by abuse, abnormal use, neglect or operation of the product in a manner inconsistent with the recommended operation described in this Can-Am Youth ATV Operator's Guide;
- Damage resulting from accident, submersion, fire, theft, vandalism or any act of God;
- Operation with fuels, oils or lubricants which are not suitable for use with the product (see in this Can-Am Youth ATV Operator's Guide);
- Damages from rust, corrosion or exposure to the elements;
- Damage resulting from water or snow ingestion;
- Incidental or consequential damages, or damages of any kind including without limitation towing, storage, telephone, rental, taxi, inconvenience, insurance coverage, loan payments, loss of time, loss of income.

### **4) Warranty Coverage Period**

This warranty will be in effect from (1) the date of delivery to the first retail consumer or (2) the date the product is first put into use, whichever occurs first and for a period of:

- – SIX (6) CONSECUTIVE MONTHS for private use or commercial use.

In AUSTRALIA and NEW-ZEALAND only, this warranty will be in effect from (1) the date of delivery to the first retail consumer or (2) the date the product is first put into use, whichever occurs first, and for a period of TWELVE (12) CONSECUTIVE MONTHS and THIRTY SIX (36) CONSECUTIVE MONTHS for Powertrain Engine and Transmission systems only, for private use or commercial use.

The repair or replacement of parts or the performance of service under this warranty does not extend the life of this warranty beyond its original expiration date.

Note that the duration and any other modalities of the warranty coverage are subject to the applicable national or local legislation in the customer's country

## 5) For Products Sold In Australia Only

Nothing in these Warranty terms and conditions should be taken to exclude, restrict or modify the application of any condition, warranty, guarantee, right or remedy conferred or implied under the Competition and Consumer Act 2010 (Cth), including the Australian Consumer Law or any other law, where to do so would contravene that law, or cause any part of these terms and conditions to be void. The benefits given to you under this limited warranty are in addition to other rights and remedies that you have under Australian law.

Our goods come with guarantees that cannot be excluded under the Australian Consumer Law. You are entitled to a replacement or refund for a major failure and for compensation for any other reasonably foreseeable loss or damage. You are also entitled to have the goods repaired or replaced if the goods fail to be of acceptable quality and the failure does not amount to a major failure.

## 6) Conditions To Have Warranty Coverage

This warranty coverage is available only if each of the following conditions has been fulfilled:

- The 2025 Can-Am Youth ATV must be purchased as new and unused by its first owner from a Can-Am ATV Distributor/Dealer authorized to distribute Can-Am ATVs in the country in which the sale occurred;
- The BRP specified pre-delivery inspection process must be completed and documented;
- The product must have undergone proper registration by an authorized Can-Am ATV Distributor/Dealer;
- The 2025 Can-Am Youth ATV must be purchased in the country or union of countries in which the purchaser resides; and
- Routine maintenance outlined in the Operator's Guide must be timely performed in order to maintain warranty coverage. BRP reserves the right to make warranty coverage contingent upon proof of proper maintenance.

BRP will not honour this limited warranty to any private use owner or commercial use owner if one of the preceding conditions has not been met. Such limitations are necessary in order to allow BRP to preserve both the safety of its products, and also that of its consumers and the general public.

## 7) What to Do to Obtain Warranty Coverage

The customer must cease using the ATV upon the appearance of an anomaly. The customer must notify a servicing Can-Am ATV Distributor/Dealer within two (2) days of the appearance of a defect, and provide it with reasonable access to the product and reasonable opportunity to repair it. The customer must also present to the authorized Can-Am ATV Distributor/Dealer proof of purchase of the product and must sign the repair/work order prior to starting the repair in order to validate the warranty repair. All parts replaced under this limited warranty become the property of BRP.

Note that the notification period is subject to the applicable national or local legislation in customer's country.

## **8) What BRP Will Do**

To the extent permitted by law, BRP's obligations under this warranty are limited to, at its sole discretion, repairing parts found defective under normal use, maintenance and service, or replacing such parts with new genuine Can-Am ATV parts without charge for parts and labour, at any authorized Can-Am ATV Distributor/Dealer during the warranty coverage period under the conditions described herein. BRP's responsibility is limited to making the required repairs or replacements of parts. No claim of breach of warranty shall be cause for cancellation or rescission of the sale of the Can-Am ATV to the owner. You may have other legal rights which may vary from country to country.

In the event that service is required outside of the country of original sale, the owner will bear responsibility for any additional charges due to local practices and conditions, such as, but not limited to, freight, insurance, taxes, license fees, import duties, and any and all other financial charges, including those levied by governments, states, territories and their respective agencies.

BRP reserves the right to improve or modify products from time to time without assuming any obligation to modify products previously manufactured.

## **9) Transfer**

If the ownership of a product is transferred during the warranty coverage period, this limited warranty, subject to its terms and conditions, shall also be transferred and be valid for the remaining coverage period provided BRP or an authorized Can-Am ATV Distributor/Dealer receives a proof that the former owner agreed to the transfer of ownership, in addition to the coordinates of the new owner.

## **10) Consumer Assistance**

In the event of a controversy or a dispute in connection with this limited warranty, BRP suggests that you try to resolve the issue at the

Can-Am ATV Distributor/Dealer level. We recommend discussing the issue with the authorized Can-Am ATV Distributor/ Dealer's service manager or owner.

If the matter still remains unresolved, contact BRP by filling out the customer contact form at **www.brp.com** or contact BRP by mail at one of the addresses listed under the *Contact Us* section of this guide.

---

# **BRP LIMITED WARRANTY FOR THE EUROPEAN ECONOMIC AREAS, THE COMMONWEALTH OF THE INDEPENDENT STATES, RUSSIA AND TURKEY: 2025 CAN-AM® YOUTH ATV**

## **1) Scope of the Limited Warranty**

Bombardier Recreational Products Inc. ("BRP") warrants its 2025 Can-Am Youth ATVs sold by distributors or dealers authorized by BRP to distribute Can-Am ATVs ("Can-Am ATV Distributor/Dealer") in member states of the European Economic Area (which is comprised of the member states of the European Union plus the United Kingdom, Norway, Iceland and Liechtenstein) ("EEA"), in member states of the Commonwealth of the Independent States (including Ukraine and Turkmenistan but excluding Russia) ("CIS"), Russia and Turkey from defects in material or workmanship for the period and under the conditions described below.

Non-factory installed parts and accessories are not covered under this limited warranty. Please refer to the applicable parts and accessories limited warranty text.

This limited warranty will become null and void if:

- the ATV was used for racing or any other competitive activity, at any point, even by a previous owner; or
- the ATV has been altered or modified in such a way so as to adversely affect its operation, performance or durability, or has been altered or modified to change its intended use.

## **2) Limitations of Liability**

TO THE EXTENT PERMITTED BY LAW, THIS WARRANTY IS EXPRESSLY GIVEN AND ACCEPTED IN LIEU OF ANY AND ALL OTHER WARRANTIES, EXPRESSED OR IMPLIED, INCLUDING WITHOUT LIMITATION ANY WARRANTY OF MERCHANTABILITY OR FITNESS FOR A PARTICULAR PURPOSE. TO THE EXTENT THAT THEY CANNOT BE DISCLAIMED, THE IMPLIED WARRANTIES ARE LIMITED IN DURATION TO THE LIFE OF THE EXPRESS WARRANTY. INCIDENTAL AND CONSEQUENTIAL DAMAGES ARE EXCLUDED FROM COVERAGE UNDER THIS WARRANTY. SOME JURISDICTIONS DO NOT ALLOW FOR THE DISCLAIMERS, LIMITATIONS AND EXCLUSIONS IDENTIFIED ABOVE. AS A RESULT, THEY MAY NOT APPLY TO YOU. THIS WARRANTY GIVES YOU SPECIFIC RIGHTS AND YOU MAY ALSO HAVE OTHER LEGAL RIGHTS WHICH MAY VARY FROM COUNTRY TO COUNTRY. BRP SHALL NOT BE HELD LIABLE IF PRODUCTS OR WARRANTY PARTS ARE NOT AVAILABLE IN YOUR COUNTRY FOR REASONS OUTSIDE OF BRP'S CONTROL.

Neither the Can-Am ATV Distributor/Dealer nor any other person has been authorized to make any affirmation, representation or warranty

regarding the product, other than those contained in this limited warranty, and if made, shall not be enforceable against BRP.

BRP reserves the right to modify this warranty at any time, being understood that such modification will not alter the warranty conditions applicable to the products sold while this warranty is in effect.

### **3) Exclusions – Are NOT Warranted**

The following are not warranted under any circumstances:

- Normal wear and tear;
- Routine maintenance items, tune ups, adjustments;
- Damage caused by failure to provide proper maintenance and/or storage, as described in this Can-Am Youth ATV Operator's Guide;
- Damage resulting from removal of parts, improper repairs, service, maintenance, modifications or use of parts not manufactured or approved by BRP or resulting from repairs done by a person that is not an authorized servicing Can-Am ATV dealer;
- Damage caused by abuse, abnormal use, neglect or operation of the product in a manner inconsistent with the recommended operation described in this Can-Am Youth ATV Operator's Guide;
- Damage resulting from accident, submersion, fire, theft, vandalism or any act of God;
- Operation with fuels, oils or lubricants which are not suitable for use with the product (see in this Can-Am Youth ATV Operator's Guide);
- Damages from rust, corrosion or exposure to the elements;
- Damage resulting from water or snow ingestion;
- Incidental or consequential damages, or damages of any kind including without limitation towing, storage, telephone, rental, taxi, inconvenience, insurance coverage, loan payments, loss of time, loss of income.

### **4) Warranty Coverage Period**

This warranty will be in effect from (1) the date of delivery to the first retail consumer or (2) the date the product is first put into use, whichever occurs first and for a period of:

1. TWENTY-FOUR (24) CONSECUTIVE MONTHS for private use.
2. SIX (6) CONSECUTIVE MONTHS for commercial use or rental use.

The product is used commercially when it is used in connection with any work or employment that generates income during any part of the warranty period. The product is also used commercially when, at any point during the warranty period, it is licensed for commercial use.

The repair or replacement of parts or the performance of service under this warranty does not extend the life of this warranty beyond its original expiration date.

Note that the duration and any other modalities of the warranty coverage are subject to the applicable national or local legislation in the customer's country.

## **5) Conditions To Have Warranty Coverage**

This warranty coverage is available only if each of the following conditions has been fulfilled:

- The 2025 Can-Am Youth ATV must be purchased as new and unused by its first owner from a Can-Am ATV Distributor/Dealer authorized to distribute Can-Am ATVs in the country in which the sale occurred;
- The BRP specified pre-delivery inspection process must be completed and documented;
- The product must have undergone proper registration by an authorized Can-Am ATV Distributor/Dealer;
- The 2025 Can-Am Youth ATV must be purchased within the country (or, in the case of EEA, union of countries) in which the purchaser resides; and
- Routine maintenance outlined in the Operator's Guide must be timely performed in order to maintain warranty coverage. BRP reserves the right to make warranty coverage contingent upon proof of proper maintenance.

BRP will not honour this limited warranty to any private use owner or commercial use owner if one of the preceding conditions has not been met. Such limitations are necessary in order to allow BRP to preserve both the safety of its products, and also that of its consumers and the general public.

## **6) What to Do To Obtain Warranty Coverage**

The customer must cease using the ATV upon the appearance of an anomaly. The customer must notify a servicing Can-Am ATV Distributor/Dealer within two (2) months of the appearance of a defect and provide it with reasonable access to the product and reasonable opportunity to repair it. The customer must also present to the authorized Can-Am ATV Distributor/Dealer, proof of purchase of the product and must sign the repair/work order prior to starting the repair in order to validate the warranty repair. All parts replaced under this limited warranty become the property of BRP.

Note that the notification period is subject to the applicable national or local legislation in customer's country.

## **7) What BRP Will Do**



To the extent permitted by law, BRP's obligations under this warranty are limited to, at its sole discretion, repairing parts found defective under normal use, maintenance and service, or replacing such parts with new genuine Can-Am ATV parts without charge for parts and labour, at any authorized Can-Am ATV Distributor/Dealer during the warranty coverage period under the conditions described herein. BRP's responsibility is limited to making the required repairs or replacements of parts. No claim of breach of warranty shall be cause for cancellation or rescission of the sale of the Can-Am ATV to the owner. You may have other legal rights which may vary from country to country.

In the event that service is required outside of the EEA, CIS, Russia or Turkey, the owner will bear responsibility for any additional charges due to local practices and conditions, such as, but not limited to, freight, insurance, taxes, license fees, import duties, and any and all other financial charges, including those levied by governments, states, territories and their respective agencies.

BRP reserves the right to improve or modify products from time to time without assuming any obligation to modify products previously manufactured.

## **8) Transfer**

If the ownership of a product is transferred during the warranty coverage period, this limited warranty, subject to its terms and conditions, shall also be transferred and be valid for the remaining coverage period provided BRP or an authorized Can-Am ATV Distributor/Dealer receives a proof that the former owner agreed to the transfer of ownership, in addition to the coordinates of the new owner, and to the extent permitted by law, that the Product remains in the country in which it was first retailed.

## **9) Consumer Assistance**

In the event of a controversy or a dispute in connection with this limited warranty, BRP suggests that you try to resolve the issue at the Can-Am ATV Distributor/Dealer level. We recommend discussing the issue with the authorized Can-Am ATV Distributor/ Dealer's service manager or owner.

If the matter still remains unresolved, contact BRP by filling out the customer contact form at [www.brp.com](http://www.brp.com) or contact BRP by mail at one of the addresses listed under the *Contact Us* section of this guide.

## **10) Additional Terms and Conditions For France**

The following terms and conditions are applicable to products sold in France only.

The seller shall deliver goods that are complying with the contract and shall be responsible for defects existing upon delivery. The seller shall also be responsible for defects resulting from packaging, assembling instructions or the installation when it is its responsibility per the contract or if accomplished under its responsibility. To be compliant with the contract, the good shall:

1. Be fit for normal use for goods similar thereto and, if applicable:
  - Correspond to the description provided by the seller and have the qualities presented to the buyer through sample or model;
  - Have the qualities that a buyer may legitimately expect considering the public declarations of the seller, the manufacturer of its representative, including in advertising or labeling; or
2. Have the characteristics mutually agreed upon as between the parties or be fit for the specific use intended by the buyer and brought to the attention of the seller and which accepted by the seller.

The action for failure to comply is prescribed after two years after delivery of the goods. The seller is responsible for the warranty for hidden defects of the good sold if such hidden defects are rendering the good unfit for the intended use, or if they diminish its use in such a way that the buyer would not have acquired the good or would have given a lesser price, had he known. The action for such hidden defects shall be taken by the buyer within 2 years of the discovery of the defect.

# **CUSTOMER INFORMATION**

---

## DATA PRIVACY INFORMATION

Bombardier Recreational Products inc., its affiliates and subsidiaries (“BRP”) is committed to protecting your privacy and support a general policy of openness about how we collect, use and disclose your personal information in the course of managing our relationship with you. **More details can be found by visiting BRP’s Privacy Policy at: <https://brp.com/en/privacy-policy.html> or by scanning the QR Code below.**

Please be assured that we have appropriate security measures in place to ensure that your personal information is protected against loss and unauthorized access.

Your personal information that may be collected by BRP, directly from you or from authorized dealers or authorized third parties, includes:

- **Contact, Demographic & Registration Information** (e.g., name, full address, phone number, email, gender, ownership history, language of communication)
- **Vehicle Information** (e.g., serial number, purchase and delivery date, unit usage, vehicle location and movements)
- **Third Party Information** (e.g., information received from BRP partners, joint-marketing activities information, social media)
- **Technological Information** (e.g., IP address, type of device, operating system, browser type, webpages you view, cookies and similar technologies when you use BRP or dealers’ websites or mobile application)
- **Interaction with BRP Information** (e.g., information collected when you call BRP’s in-house sales representatives, buy items on a BRP web Site, sign up for BRP emails, participate in BRP-sponsored contests and sweepstakes or attend BRP-sponsored events)
- **Transactional Information** (e.g., information necessary to handle returns, payment information when you purchase our products or services through our websites or mobile applications and other issues related to your purchase of BRP products)

This information may be used and processed for the following purposes:

- Safety & Security
- Customer Support for Sales & After Sales (e.g., complete or follow up with you about your purchase or maintenance)
- Registration & Warranty
- Communication (e.g., sending you a BRP satisfaction survey)
- Online Behavioural Advertising, Profiling and Location-Based Services (e.g., offer customized experience)
- Compliance & Dispute Resolution
- Marketing & Advertising
- Assistance (e.g., help with any delivery issues, handle returns, and other issues related to your purchase of BRP products).

We also may use personal information to generate aggregated or statistical data that no longer identifies you personally.

**Your personal information may be disclosed to the following: BRP, BRP's authorized dealerships, distributors, service providers, advertising & market research partners and other authorized third parties.**

We may receive information about you from diverse sources, including third parties, such as BRP's authorized dealerships and partners, with whom we offer services or engage in joint-marketing activities. We may also receive information about you from social media platforms such as Facebook and Twitter, when you interact with us on those platforms.

Depending on the circumstances, your personal information may be communicated outside the region where you reside. Your personal information is retained only for as long as necessary for the purpose for which we obtained it and according to our retention policies.

To exercise your data privacy rights (e.g. right of access, right of rectification), to withdraw your consent in order to be removed from the address list for marketing purposes or for the satisfaction survey or for general data privacy questions, please contact BRP's Data Protection Officer at or by mail at **privacyofficer@brp.com** or by mail at: BRP Legal Service, 726 St-Joseph, Valcourt, Quebec, Canada, J0E 2L0.

**When BRP processes your personal information, they do so in compliance with its Privacy Policy available at: <https://www.brp.com/en/privacy-policy.html> or by using the following QR Code.**



---

# CONTACT US

*www.brp.com*

## **Asia Pacific**

### **BRP Asia**

107D and 107E, 17/F, Tower 1,  
Grand Century Place, Mongkok,  
Kowloon, Hong Kong

### **Australia**

Level 26  
477 Pitt Street  
Sydney, NSW 2020

### **China**

上海市徐汇区衡山路10号6号楼301  
Rm 301, Building 6,  
No.10 Heng Shan Rd,  
Shanghai, China

### **Japan**

21F Shinagawa East One Tower  
2-16-1 Konan, Minato-ku-ku,  
Tokyo 108-0075

### **New Zealand**

Suite 1.6, 2-8 Osborne Street,  
Newmarket, Auckland 2013

## **Europe, Middle East and Africa**

### **Belgium**

Oktrooiplein 1  
9000 Gent

### **Czech Republic**

Stefanikova 43a  
Prague 5  
150 00

### **Germany**

Itterpark 11  
40724 Hilden

### **Finland**

Isoaavantie 7  
PL 8040  
96101 Rovaniemi

**France**

Arteparc Bâtiment B  
Route de la côte d'Azur,  
13 590 Meyreuil

**Norway**

Ingvald Ystgaardsvei 15  
N-7484 Trondheim  
Salg, marketing, ettermarked

**Sweden**

Spinnvägen 15  
903 61 Umeå  
Sweden 90821

**Switzerland**

Avenue d'Ouchy 4-6  
1006 Lausanne

**Latin America**

**Brazil**

Av. James Clerck Maxwell, 230  
Campinas, Sao Paulo  
CEP 13069-380

**Mexico**

Av. Ferrocarril 202  
Parque Industrial Querétaro  
Santo Rosa Jauregui, Querétaro  
C.P. 76220

**North America**

**Canada**

3200A, rue King Ouest,  
Suite 300  
Sherbrooke (Québec) J1L 1C9

**United States of America**

10101 Science Drive  
Sturtevant, Wisconsin  
53177

---

## CHANGE OF ADDRESS AND OWNERSHIP

If your address has changed or if you are the new owner of the vehicle, be sure to notify BRP by either:

- Notifying an authorized Can-Am dealer.
- **North America Only:** calling at 1 888 272-9222.
- Mailing one of the change of address cards on the following pages at one of the BRP addresses indicated in the *Contact Us* section of this guide.

In case of change of ownership, please join a proof that the former owner agreed to the transfer.

Notifying BRP, even after the expiration of the limited warranty, is very important as it enables BRP to reach the vehicle owner if necessary, like when safety recalls are initiated. It is the owner's responsibility to notify BRP.

**STOLEN UNITS:** If your personal vehicle is stolen, you should notify BRP or an authorized Can-Am dealer. We will ask you to provide your name, address, phone number, the vehicle identification number and the date it was stolen.



CHANGE OF ADDRESS AND OWNERSHIP

CHANGE OF ADDRESS  CHANGE OF OWNERSHIP  

VEHICLE IDENTIFICATION NUMBER

Model Number	Vehicle Identification Number (V.I.N.)
--------------	----------------------------------------

OLD ADDRESS OR PREVIOUS OWNER:

NAME \_\_\_\_\_

NO. \_\_\_\_\_ STREET \_\_\_\_\_ APT \_\_\_\_\_

CITY \_\_\_\_\_ STATE/PROVINCE \_\_\_\_\_ ZIP/POSTAL CODE \_\_\_\_\_

COUNTRY \_\_\_\_\_ TELEPHONE \_\_\_\_\_

NEW ADDRESS OR NEW OWNER:

NAME \_\_\_\_\_

NO. \_\_\_\_\_ STREET \_\_\_\_\_ APT \_\_\_\_\_

CITY \_\_\_\_\_ STATE/PROVINCE \_\_\_\_\_ ZIP/POSTAL CODE \_\_\_\_\_

COUNTRY \_\_\_\_\_ TELEPHONE \_\_\_\_\_

E-MAIL ADDRESS \_\_\_\_\_

CHANGE OF ADDRESS  CHANGE OF OWNERSHIP  

VEHICLE IDENTIFICATION NUMBER

Model Number	Vehicle Identification Number (V.I.N.)
--------------	----------------------------------------

OLD ADDRESS OR PREVIOUS OWNER:

NAME \_\_\_\_\_

NO. \_\_\_\_\_ STREET \_\_\_\_\_ APT \_\_\_\_\_

CITY \_\_\_\_\_ STATE/PROVINCE \_\_\_\_\_ ZIP/POSTAL CODE \_\_\_\_\_

COUNTRY \_\_\_\_\_ TELEPHONE \_\_\_\_\_

NEW ADDRESS OR NEW OWNER:

NAME \_\_\_\_\_

NO. \_\_\_\_\_ STREET \_\_\_\_\_ APT \_\_\_\_\_

CITY \_\_\_\_\_ STATE/PROVINCE \_\_\_\_\_ ZIP/POSTAL CODE \_\_\_\_\_

COUNTRY \_\_\_\_\_ TELEPHONE \_\_\_\_\_

E-MAIL ADDRESS \_\_\_\_\_



CHANGE OF ADDRESS AND OWNERSHIP

Model No. \_\_\_\_\_

**VEHICLE**

IDENTIFICATION NUMBER (V.I.N.) \_\_\_\_\_

**ENGINE**

IDENTIFICATION NUMBER (E.I.N.) \_\_\_\_\_

**Owner:** \_\_\_\_\_  
NAME

\_\_\_\_\_  
No. STREET APT

\_\_\_\_\_  
CITY STATE/PROVINCE ZIP/POSTAL CODE

**Purchase Date** \_\_\_\_\_  
YEAR MONTH DAY

**Warranty Expiry Date** \_\_\_\_\_  
YEAR MONTH DAY

To be completed by the dealer at the time of the sale.

DEALER IMPRINT AREA

## **⚠ WARNING**

THIS VEHICLE CAN BE HAZARDOUS TO OPERATE. A collision or rollover can occur quickly, even during routine maneuvers such as turning and driving on hills or over obstacles, if you fail to take proper precautions.

SEVERE INJURY OR DEATH can result if you do not follow these instructions:

- BEFORE YOU OPERATE THIS VEHICLE, READ THIS OPERATOR'S GUIDE, ALL ON PRODUCT SAFETY LABELS AND WATCH THE SAFETY VIDEO.



- NEVER OPERATE THIS VEHICLE WITHOUT PROPER INSTRUCTIONS. Complete a certified training course.
- DO NOT EXCEED VEHICLE SEATING CAPACITY
- NEVER CARRY A PASSENGER. You increase your risk of losing control if you carry a passenger.

- NEVER OPERATE THIS VEHICLE ON A PAVED SURFACE. You increase your risk of losing control if you operate this vehicle on pavement.
- NEVER OPERATE THIS VEHICLE ON PUBLIC ROADS. You can collide with another vehicle if you operate this vehicle on a public road.
- OPERATOR SHOULD ALWAYS WEAR an approved helmet, eye protection, and protective clothing.
- NEVER USE WITH DRUGS OR ALCOHOL. They slow reaction time and impair judgment.
- NEVER OPERATE THIS VEHICLE AT EXCESSIVE SPEEDS. You increase your risk of losing control if you operate this vehicle at speeds too fast for the terrain, visibility conditions, or your experience.
- NEVER ATTEMPT WHEELIES, JUMPS, OR OTHER STUNTS.

®TM and the BRP logo are trademarks of BOMBARDIER RECREATIONAL PRODUCTS INC. or its affiliates.

©2024 BOMBARDIER RECREATIONAL PRODUCTS INC. ALL RIGHTS RESERVED.

[www.brp.com](http://www.brp.com)

**ALUMACRAFT®**

**CAN-AM®**

**LYNX®**

**MANITOU®**

**QUINTREX®**

**ROTAX®**

**SEA-DOO®**

**SKI-DOO®**



219002438

PRINTED IN TAIWAN.