

OPERATOR'S GUIDE



ALUMACraft®

P/N 3019-0019941, Rev - 1
APR. 2024



WARNING: Operating, servicing and maintaining a recreational marine vessel can expose you to chemicals including engine exhaust, carbon monoxide, phthalates, and lead, which are known to the State of California to cause cancer and birth defects or other reproductive harm. To minimize exposure, avoid breathing exhaust, service your vessel in a well-ventilated area and wear gloves or wash your hands frequently when servicing this vessel. For more information go to www.P65warnings.ca.go/marine

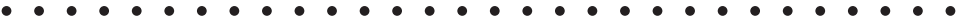

RECORD IMPORTANT INFORMATION!

HULL

HIN	Date Purchased
Dealer	Phone
Ignition	Key Number
Registration #	State

OUTBOARD ENGINE

Model #	Serial #
---------	----------

TROLLING MOTOR

Model #	Serial #
---------	----------

TRAILER

Model #	Serial #
---------	----------

ACCESSORY 1

Model #	Serial #
---------	----------

ACCESSORY 2

Model #	Serial #
---------	----------

ACCESSORY 3

Model #	Serial #
---------	----------

BRP MARINE US INC.

315 West St. Julien Street
St. Peter, Minnesota 56082-1800

[507] 931-1050 Phone

[507] 931-9056 FAX

If you have a question, problem, concern
or comment, visit our website at:
www.alumacraft.com.

INTRODUCTION

Congratulations on your choice of boats. The safety, durability and craftsmanship bred into your Alumacraft are features designed to let you fully enjoy your boating experience. Alumacraft boats are made from the best available materials and meet or exceed all current National Marine Manufacturers Association (NMMA) standards and U.S Coast Guard regulations in effect at the date of manufacture. Before using your new Alumacraft, please take the time to carefully read this guide. This will assist you in the proper care and operation of your boat and its equipment. Your Alumacraft dealer is also an excellent source of boating information and service. The dealer can set up your boat, properly adjust its trailer and mount your motor for you. The dealer also has the knowledge and experience to answer most questions you might have about your new Alumacraft.

Finally, remember that you are responsible at all times for ensuring the safety of your boat's passengers and that of other waterway users. Practice courteous and responsible boating each time you enjoy your Alumacraft boat! Join us in our efforts to drive positive changes and foster a more caring community with our Responsible Rider program.

The Responsible Rider program is a key element of our Corporate Social Responsibility initiative that invites everyone in the marine community to come together and rethink how we approach safety, riding etiquette, and the environment.

To learn more about Responsible Rider, including tips and tricks on safety, boating etiquette and the environment, visit www.alumacraft.com/responsible-rider Or, use the following QR code.



ABOUT THIS OPERATOR'S GUIDE

This Operator's Guide has been prepared to acquaint the owner / operator or passenger with this boat and its various controls, maintenance and safe riding instructions. Keep this Operator's Guide in the boat as you can refer to it for the operation, instructing others, maintenance and troubleshooting. This Operator's Guide is available in several languages. In the event of any discrepancy, the English version shall prevail.

If you want to view and/or print an extra copy of your Operator's Guide, simply visit www.operatorsguides.brp.com

The information contained in this Operator's Guide is correct at the time of printing. However, BRP Marine US Inc. maintains a policy of continuous improvement of products without imposing upon itself any obligation to install them on products previously manufactured. Due to late changes, some differences between the manufactured product and the descriptions and / or specifications in this guide may occur. BRP Marine US Inc. reserves the right at any time to discontinue or change specifications, designs, features, models or equipment without incurring any obligation upon itself.

IDENTIFICATION NUMBERS

Identification numbers are important! Safeguard information about your boat by recording the Hull Identification Number (HIN) and model of your boat, and model and serial numbers of the engine, trailer, trolling motor, and accessories on the inside front cover of this operator's guide. Also, store a copy of these numbers off your boat. In the event of theft, damage, etc., submit these numbers to the local authorities, your insurance agent and your dealer.

The HIN is located on the upper, starboard corner of the transom. It must be clearly visible and may not be removed or altered in any way as regulated by federal law.

BOATING TERMINOLOGY

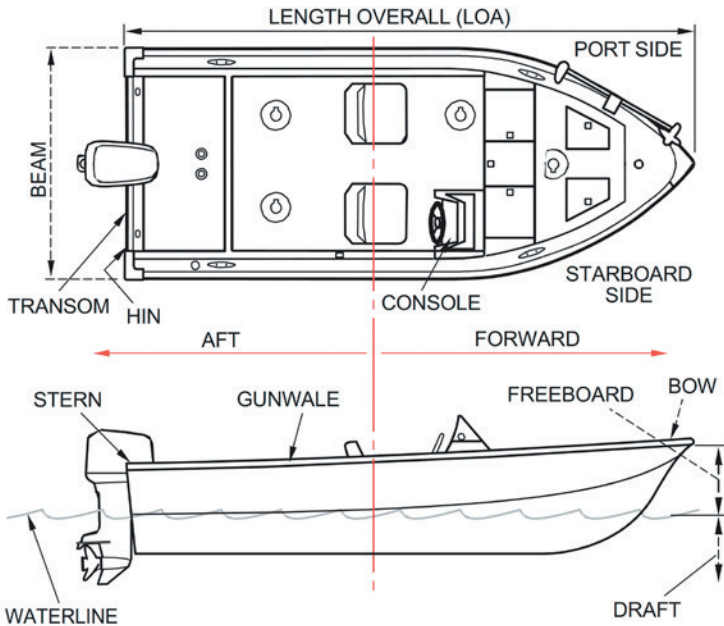

An easy way to distinguish port from starboard is to remember that "port" and "left" both have four letters.

RESTRICTED AREAS

Before boating, check with Local, State and Federal authorities to identify restricted areas. **Because of the threat of terrorism, the U.S. Coast Guard has and will continue to implement strict limits on watercraft near U.S. Navy and Coast Guard ships and other potential targets.**

TABLE OF CONTENTS

SECTION 1

BOATING SAFETY	6
Powering Your Boat	7
Safety Labels	7
Safety While Boating	10
General Water Sport Precautions.....	12
Boating Regulations.....	12
Boater Responsibilities	13
Emergencies	16
Hazardous Conditions.....	18
Safe Operating Speed	20
General Precautions.....	21
Foam Flotation.....	22
More About Boating.....	22
The Environment.....	23
Aquatic Invasive Species.....	25
Compliance Labels.....	27

SECTION 2

RULES OF THE ROAD	30
Aids to Navigation.....	30
Right-of-Way.....	33

SECTION 3

SYSTEMS AND COMPONENTS.....	36
Propellers	36
Electrical System	37
Console Instruments	37
Controls.....	39
Safety & Functional Features.....	40
Reboarding Means.....	43
Comfort & Convenience Features.....	45
Ski Pylon.....	49
Fuel System	50
Portable Fuel Tanks.....	53

SECTION 4

GETTING UNDERWAY	54
Lubrication.....	54
Fueling.....	54
Boarding.....	55
Pre-Operation Checklist	57
Starting.....	57
Drive Trim Angle	58
Steering.....	59
Operation Checklist.....	59
Stopping.....	59
Anchoring.....	59
Docking.....	60
Post-Operation Checklist.....	61

SECTION 5

TRAILERING	62
Choosing the Correct Trailer	62
Transom Support.....	62
Bunk Trailers	63
Roller Bunk Trailers.....	64
Keel Support.....	64
Winch Stand and Bow Support.....	65
Boat Stabilization.....	65
Self Centering Keel Roller Trailers	65
Securing the Boat to the Trailer	65
Trailering	66
Launching.....	67

SECTION 6

MAINTENANCE AND STORAGE	69
Care of Your Boat's Appearance.....	69
Maintenance and Storage.....	71
Attaching Accessories.....	74
Keeping Boat Docked in the Water.....	74
Storage	75
Reactivating the Boat after Storage.....	76

SECTION 7

FEATURES FOR THE ANGLER	77
Livewells	78

SECTION 8

ROTAX OUTBOARD EQUIPPED MODELS	81
Max Deck.....	81
LinQ Accessories	81

SECTION 9

TROUBLESHOOTING	82
General Boat Operation Problems.....	82
Steering.....	83
Leaks.....	84
Electrical	85
Plumbing.....	86
Marine Wiring Color Code.....	86
Typical System Wiring Diagram.....	87

SECTION 10

GLOSSARY OF TERMS	88
--------------------------------	-----------

WARRANTY

Refer to the Warranty Guide for further information regarding warranty and CARB warranty specific to your boat.

SECTION 1: BOATING SAFETY

BRP Marine US Inc. wants your boating experience to be a safe one. This section is devoted to general boating safety and defines the meaning of the safety-related statements used throughout this operator's guide.

Boating accidents kill and injure many people. If you know and use safe boating practices, you will enjoy your boat more and not be a hazard to yourself or others.



**The Safety Alert Symbol means ATTENTION! BECOME ALERT!
YOUR SAFETY IS INVOLVED!**

DANGER

Indicates an imminently hazardous situation which, if not avoided, will result in death or serious injury.

WARNING

Indicates a potentially hazardous situation which, if not avoided, could result in death or serious injury.

CAUTION

Indicates a potentially hazardous situation which, if not avoided, could result in minor or moderate injury.

NOTICE

Notice indicates installation, operation, or maintenance information which is important and, if not followed, could result in property damage.

You are likely to encounter a variety of situations beyond those listed in this operator's guide that require safe practices. Be ready, and make safety a first priority at all times!

The precautions listed in this operator's guide and on your boat are not all-inclusive. If a procedure, method, tool, or part is not specifically recommended, you must be satisfied that it is safe for you and others, and that the boat will not be damaged or made unsafe as a result of your decision.

REMEMBER - USE COMMON SENSE WHEN OPERATING YOUR BOAT!

POWERING YOUR BOAT

When powering your boat never exceed the maximum capacity stated on the capacity tag.

KICKER ENGINES

Kicker engines up to 9 hp can be mounted on the port side of transom on boats rated for 150 hp and up. Provisions have been made for floatation in this location.

 **WARNING**

**PROVISIONS HAVE NOT
BEEN MADE FOR
TWIN (MAIN)
ENGINE APPLICATIONS**

SAFETY LABELS

The safety labels present on your Alumacraft boat serve as reminders of important safety considerations. Following are the labels commonly found on Alumacraft boats, their applicability and location may vary between models. Note their locations on your own boat, read them carefully and follow their directives. Ask passengers to do the same. If safety labels become damaged, they should be replaced immediately by contacting your Alumacraft dealer.

BOATING SAFETY LABELS

The following safety labels were affixed to your boat at the time of manufacture and must remain legible. Should one of them be missing or become damaged, contact your dealer for immediate replacement.

 **WARNING**



PINCH POINT.
Keep hands and
fingers clear.

NOTICE	BOATER'S CHECKLIST
<small>For maximum enjoyment and safety, check each of these items BEFORE YOU START YOUR ENGINE.</small>	
<ul style="list-style-type: none">✓ DRAIN PYLE (optional)✓ LIFE-SAVING DEVICES (Ensure proper amount, sizes, types, locations)✓ FUEL SYSTEM (check for leaks and leaks)✓ SAFETY (Overboard and clear and light)✓ BLUNDER (Use for 4 strokes)	<ul style="list-style-type: none">✓ CAPACITY (Ensure persons, weight and gear do not exceed weight limitations)✓ All passengers are in DESIGNATED OCCUPANT POSITION✓ WEATHER CONDITIONS (Check to ensure it is safe to go out)✓ ELECTRICAL EQUIPMENT (Cables, horns, bilge pump are working)✓ EMERGENCY GEAR (Fire extinguisher, ladder, second signaling device, horn, VHF, etc.)

 **WARNING**

SKI PYLON IS FOR SKIING, WAKE BOARDING AND KNEE BOARDING ONLY.
DO NOT USE SKI PYLON FOR ANY OTHER PURPOSE (I.E. TUBING, PARASAILING, TOWING, ETC.).
PINCH POINT BETWEEN PYLON AND MOTOR. REMOVE PYLON PRIOR TO TRIMMING MOTOR UP. DO NOT SIT BESIDE OR BEHIND SKI PYLON WHILE IN USE. SEE OWNERS MANUAL FOR ADDITIONAL INFORMATION.
P/N: 22160010501 REV B

 **WARNING**

AVOID SERIOUS INJURY OR DEATH. DO NOT OCCUPY BOW SEAT POSITION WHEN BOAT IS OPERATED AT SPEEDS ABOVE 5 MPH. AVOID OBSTRUCTIONS TO DRIVER'S VISIBILITY. REMOVE AND PROPERLY STORE BOW SEAT BEFORE GETTING UNDERWAY.

⚠ WARNING



Carbon monoxide (CO) can cause brain damage or death.

Engine and generator exhaust contains odorless and colorless carbon monoxide gas.

Signs of carbon monoxide poisoning include nausea, headache, dizziness, drowsiness, and lack of consciousness.

Get fresh air if anyone shows signs of carbon monoxide poisoning.

See Owner's Manual for information regarding carbon monoxide poisoning.

HW-208-14

⚠ DANGER

- **CONTACT WITH A SPINNING PROPELLER WILL CAUSE SERIOUS INJURY OR DEATH.**
- **SHUT OFF ENGINES** while people are in the water near the boat, on the swim latform, or on the boarding ladder.
- **NEVER OPERATE IN REVERSE TOWARD A PERSON** in the water.



⚠ WARNING

CENTER SEAT POSITION IS NOT DESIGNED TO BE OCCUPIED WHEN BOAT IS OPERATED AT SPEEDS ABOVE 5 MPH. HAND HOLDS ARE NOT PROVIDED. AVOID SERIOUS OR FATAL INJURY DUE TO BEING THROWN OUT OF SEAT.



⚠ WARNING

Failure to attach the motor emergency shutoff lanyard can result in serious injury or death of person(s) thrown overboard, when for example, striking a wave, wake or submerged object. If motor does not shutoff, boat could circle and strike person(s) in water. Boat operator must always make sure to attach the emergency shutoff lanyard prior to starting the gasoline engine and that lanyard remains securely attached at all times when operating the boat. Consult your motor owners manual for more detailed information regarding the emergency shutoff lanyard.

⚠ WARNING

AVOID SERIOUS INJURY OR DEATH

SEAT PEDESTAL CAN ONLY BE MOVED BY A CERTIFIED ALUMACRAFT DEALER

SEE OWNERS MANUAL FOR ADDITIONAL INFORMATION

P/N: 221.60010439 REV A

⚠ WARNING

PROVISIONS HAVE NOT BEEN MADE FOR TWIN (MAIN) ENGINE APPLICATIONS

⚠ WARNING

SHOCK AND ARC FLASH EXPLOSION HAZARD

ADDITION, MODIFICATION OR RELOCATION OF FUEL SYSTEM AND/OR ELECTRICAL COMPONENTS CAN RESULT IN ACCIDENTAL SHORT-CIRCUITING TO FUEL SYSTEM. DIELECTRIC PROTECTION SHIELDING MUST BE INSTALLED ON METALLIC FUEL SYSTEM COMPONENTS IF DISTANCE BETWEEN BATTERY TERMINAL AND METALLIC FUEL COMPONENT IS LESS THAN 12 INCHES (203 mm) TO COMPLY WITH ABYC STANDARD E-10.7.8

P/N: 221.60009117 REV A

⚠ WARNING

NEVER EXCEED SPECIFIED FUSE RATINGS OR BYPASS CIRCUIT BREAKER SAFEGUARDS. ALWAYS USE PROPER FUSE TYPE AND RATING WHEN CHANGING OR REPLACING FUSES. REOCCURRING BLOWN FUSES AND/OR TRIPPED CIRCUIT BREAKERS INDICATE A SERIOUS PROBLEM REQUIRING IMMEDIATE ATTENTION. FAILURE TO CORRECT PROBLEM MAY RESULT IN SEVERE PERSONAL INJURY AND/OR DAMAGE TO ELECTRONICS AND/OR ELECTRICAL SYSTEM

⚠ DANGER	
	<p>CONTACT WITH A SPINNING PROPELLER WILL CAUSE SERIOUS INJURY OR DEATH.</p> <p>STAY CLEAR OF BOAT AND STAY OFF SWIM PLATFORM AND BOARDING LADDER WHILE ENGINE IS RUNNING.</p>

⚠ WARNING
<p>SKI PYLON IS FOR SKIING, WAKE BOARDING AND KNEE BOARDING ONLY.</p> <p>DO NOT USE SKI PYLON FOR ANY OTHER PURPOSE (I.E. TUBING, PARASAILING, TOWING, ETC.).</p> <p>PINCH POINT BETWEEN PYLON AND MOTOR. REMOVE PYLON PRIOR TO TRIMMING MOTOR UP. DO NOT SIT BESIDE OR BEHIND SKI PYLON WHILE IN USE. SEE OWNERS MANUAL FOR ADDITIONAL INFORMATION.</p> <p><small>P/N: 22160010501 REV.B</small></p>

⚠ WARNING
<p style="text-align: center;">AVOID SERIOUS INJURY OR DEATH</p> <ul style="list-style-type: none"> DISLODGED SKI PYLON MAY STRIKE SKIER OR OCCUPANTS OF BOAT. INSTALL SKI PYLON SECURELY BEFORE USE. <p>With pylon fully seated in under deck receiver and clevis pin installed the red line should be even with the top of the base. Failure to secure the pylon may result in injury or death.</p> <p style="text-align: center;"></p> <p style="text-align: right;"><small>LABEL # 6123060</small></p>

WARNING	<p style="text-align: center;">No Ventilation is Provided. Fuel Vapors are a Fire and Explosion Hazard. To Avoid Injury or Death, Do <u>NOT</u> Store Fuel or Flammable Liquids Here.</p>
	

⚠ WARNING	<p>CONTENTS CAN BE UNDER PRESSURE AVOID SERIOUS INJURY OR DEATH FROM FIRE OR EXPLOSION OPEN SLOWLY IN WELL VENTILATED AREA NO SMOKING OR OPEN FLAMES</p>
------------------	--

⚠ WARNING
<p>Avoid serious injury or death from fire or explosion resulting from leaking fuel. Inspect system for leaks at least once a year.</p> <p>NMMA[®] <small>NW-201-19</small></p>

WARNING
<p>DAMAGE MAY RESULT IF MOTOR IS TRIMMED UP WITH SEAT AND PEDESTAL IN THIS BASE!</p>



⚠ DANGER	
	<p>Carbon monoxide (CO) can cause brain damage or death. Engine and generator exhaust contains odorless and colorless carbon monoxide gas. Carbon monoxide will be around the back of the boat when engines or generators are running. Move to fresh air if you feel nausea, headache, dizziness, or drowsiness.</p> <p style="text-align: right;"><small>REV.09/02/11</small></p>

⚠ NOTICE
<p>THIS BOAT IS EQUIPPED WITH CIRCUIT BREAKERS. MANUAL RESET CIRCUIT BREAKERS MUST BE RESET BY PRESSING RESET BUTTON ON CIRCUIT BREAKER. AUTO RESET CIRCUIT BREAKERS WILL RESET AUTOMATICALLY AFTER OVERLOAD.</p>

SAFETY WHILE BOATING

Boating-related accidents are generally caused by the operator's failure to follow basic safety rules or written precautions. Most accidents can be avoided if the operator is completely familiar with the boat, its operation and can recognize potentially hazardous situations.

In addition to everyday safety, failure to observe the safety recommendations may result in severe personal injury or death to you and/or to others. Use caution and common sense when operating your boat. Don't take unnecessary chances, and remember that if you are skiing, at least three people are needed for safe towing.

Whether you use your Alumacraft boat for fishing, pleasure or skiing, these are important things to know about safe boating.



Failure to adhere to these warnings may result in severe injury or death to you and/or others. Read, follow, and understand all safety labels on your boat.

- **Look before you turn the boat. As a boater you are obligated to maintain a course and speed unless it is safe to alter course and speed. Look before you turn.**
- **Improper operation of the boat is extremely dangerous. Operators must read and understand all operating guides supplied with the boat before operation.**
- **On-board equipment must always conform to the governing federal, state and local regulations.**
- **DO NOT operate the boat while under the influence of alcohol or other drugs.**
- **DO NOT stand or allow passengers to stand in the boat, or sit on the transom, seat backs, engine cover or sides of the boat while the engine is running. You or others may be thrown from the boat.**
- **DO NOT allow any type of spark or open flame on board. It may result in fire or explosion.**
- **DO NOT leave children in the boat without adult supervision.**
- **DO NOT sit in front of the operator to avoid obstructing the operator's view.**
- **DO NOT dive from the boat without being absolutely sure of the depth of the water, otherwise severe injury or death may occur from striking the bottom or submerged objects.**
- **DO NOT swim near the boat when the engine is running. Being in NEUTRAL is not enough, the propeller may still be turning and carbon monoxide may be present.**
- **DO NOT replace your boat's marine parts with automotive parts.**
- **DO NOT remove or modify any components of the fuel system except for maintenance by qualified personnel. Tampering with fuel components may cause a hazardous condition or violate federal environmental laws.**
- **DO NOT wrap ski lines or mooring lines around any body part which may become entangled in the line if you fall overboard and the boat is moving.**
- **Keep track of ski lines and dock lines so they do not become entangled in the propeller.**
- **Be sure to securely attach the engine Emergency Stop switch lanyard to a part of your clothing, such as a belt loop, when operating the boat. The use of emergency stop switch lanyards is required by US Federal Law.**

- **Be sure to keep a watch for other boats, swimmers and obstructions in the water. Stay away from other boats and personal watercraft.**
- **Be sure to have an experienced operator at the helm and always have at least three people present for safe towing - one to drive, one to observe and one to ski or ride.**
- **Seek shelter from open water if there is threat of lightning.**
- **Operate slowly in congested areas such as marinas and mooring areas.**
- **The bow may be slippery, do not go forward while the engine is running.**
- **When you leave the boat take the keys with you. This will keep untrained and unauthorized persons from operating the boat.**
- **Exhaust fumes contain carbon monoxide (CO), which is an odorless and colorless gas. Carbon monoxide is toxic and can be fatal if breathed over an extended period of time.**
- **DO NOT operate the engine in a confined space.**
- **DO NOT go under the boat cover with the engine running or shortly after the engine has been running.**
- **DO NOT use boarding platform with the engine running.**
- **DO NOT "teak surf."**
- **Allow adequate ventilation with fresh air before entering.**
- **Slow down when crossing waves or wake in order to minimize the impact on passengers and the boat.**

CARBON MONOXIDE

READ, UNDERSTAND and be FAMILIAR with the information contained on warning labels and adhere to the boat operation practices described on them. The United States Coast Guard issued a SAFETY ALERT on August 28, 2001 that covers some of the issues of improper use of the boarding platform. The SAFETY ALERT and portions of the accompanying information follow:

Every year tragic deaths occur from the negligence of unsafe boating and dangerous activities. Experts say, "many of these deaths may have been caused by an invisible hazard, carbon monoxide poisoning." Taking the risk of swimming under a boarding platform when the engine is running, skiing within 20 feet (6.1 meters), "teak surfing" or "dragging" behind a moving boat can be fatal.

DO NOT use the boarding platform or ladder for any other purpose than boarding the boat or preparation of entering the water, and DO NOT use the boarding platform or ladder when the engine is running.

SAFETY ALERT FROM AUGUST 28, 2001:

The United States Coast Guard advised boaters not to “Teak Surf.” Recent boating fatalities revealed that carbon monoxide (CO) emitted from a vessel’s exhaust resulted in CO poisoning and the death of at least six teak surfers. “Teak Surfing” places the individual in position directly exposed to the CO in the engine’s exhaust. This may result in a loss of coherent responses and even death. In addition, “Teak Surfing” dangerously exposes the individual to a possible propeller injury, and since it is done without a life jacket (PFD), it significantly increases the probability of drowning. Therefore, the Coast Guard stresses, “Teak Surfing” is a very dangerous activity and advises boaters not to participate in it. Carbon monoxide is one of the most dangerous gases. It impairs and can often lead to death. It is important to the Coast Guard that it should be avoided in every circumstance.

GENERAL WATER SPORT PRECAUTIONS

- **DO NOT ski in shallow water, close to shore or in water where you do not know the depth or what is beneath the surface.**
- **DO NOT put your arm, head, or any other part of your body through the handle-bridle of the ski line nor wrap the line around any part of the body at any time.**
- **DO NOT ski at night or directly in front of other boats.**
- **DO NOT jump from a boat that is moving at any speed, nor enter or exit the water when the engine is running (RUN).**
- **DO NOT approach the boat if the engine is running.**
- **DO NOT ski near swimming areas, beaches or personal watercraft.**
- **DO NOT follow directly behind another boat or skier without leaving an adequate safe distance.**
- **DO NOT “back up” to anyone in the water.**
- **DO NOT ski with multiple skiers with different length ropes.**
- **DO NOT ski in limited visibility conditions.**
- **DO NOT approach the rear of the boat while the engine is running.**

BOATING REGULATIONS

The U.S. Coast Guard is the authority of the waterways and are there to help the boating public. State boating regulations are enforced by State authorities. You are subject to marine traffic laws and “Rules of the Road” for both federal and state waterways. It is mandatory to stop, if signaled to do so by enforcement officers, and permit your boat to be boarded if asked. In addition, always take note of the specific lake rules posted at the launch access sites on the body of water you wish to navigate.

There is information prepared by the Coast Guard, available to you which explain rules of the road, international and inland regulations, and much more than is presented in this operator’s guide. For more information, contact your local U.S. Coast Guard Unit or visit <https://www.uscgboating.org/>

BOATER RESPONSIBILITIES

REGISTRATION

The U.S. Coast Guard requires that all power boats operated on the navigable waters of the United States be registered in the state of main use. Many states also require registration in that state whenever boating on waters within their state boundary. Always contact your state boating authorities and neighboring states for information on boat and trailer registration. Your dealer may be able to supply you with the appropriate forms.

INSURANCE

You must get insurance before operating your new boat. Loss by fire, theft or other causes, and liability protection against accidents make such coverage a must for responsible boaters. The boat owner is legally responsible for any damage or injury caused when he or someone else operating the boat is involved in an accident. Many states have laws requiring minimum insurance needs. Your insurance agent will be able to supply you with more information.

EDUCATION

This operator's guide is not intended to be a complete training guide on all aspects of safe boating and proper boat operation. Many states require operators under the age of 18 to be licensed in small boat operation and offer courses for training and certification. BRP Marine US Inc. strongly recommends that prior to using your boat, you attend a boating safety course offered by the U.S. Coast Guard, U.S. Coast Guard Auxiliary or U.S. Power Squadron in your area. You can contact the U.S. Coast Guard by visiting <https://uscgboating.org/>.

Some states require youths of a certain age to complete a boating safety course before operating any watercraft. Many others require operators under the age of 18 to be licensed in small boat operation.

Minors must be supervised by an adult whenever operating a boat. Many states have laws regarding the minimum age and licensing requirements of minors. Be sure to contact the state boating authorities for information.

REQUIRED SAFETY EQUIPMENT

The U.S. Coast Guard requires that boats be equipped with safety gear on board at all times. Alumacraft boats are Class A (16' and under) or Class 1 (16' to 26') as classified by the U.S. Coast Guard. Required equipment for inland waters includes:

Fire Extinguisher

Most Alumacraft boats require a Class B fire extinguisher. It must be a 2 lb. (0.9 kg) dry chemical, 1.25 lb. (0.6 kg) foam unit or 4 lb. (1.8 kg) CO2 extinguisher mounted in a readily accessible location.

Sound Signaling Device

Most Alumacraft boats have a horn. If you do not have a horn, you will need a whistle, bell or an aerosol sound device.

Visual Signaling Device

If you will be on the Great Lakes or coastal waters with your Alumacraft, a visual signal device is required. During daylight hours, this can be a standard orange distress flag. For night use, Coast Guard approved flares are required. Check with your Alumacraft dealer or the Coast Guard for specific information concerning these devices.

Navigation Lights

The lights (if provided) on your Alumacraft boat serve different purposes. Some are for navigation and safety needs, while others are for your comfort and convenience. The lights present on your Alumacraft boat vary by model. Please contact your Alumacraft dealer before adding any extra lights to your boat.

Boats must display navigation lights when they are being operated between sunset and sunrise, and during periods of poor visibility, including rain and fog. These lights help to alert other boaters of your presence and course. Follow all laws concerning the use of navigation lights.

The navigation lights include the white stern light (sometimes referred to as the all-around or anchor light) and the red/green bow light(s). The green navigation light is always on the starboard (right) side of the boat. The red navigation light is always on the port (left) side of the boat. Please keep this information in mind as you see other boats approaching you on the water.

Some models of Alumacraft boats come equipped with hull-mounted bow navigation lights. When these models are operated in USCG navigable or international waters, these models need to be equipped with a COLREG-compliant plug-in pole bow navigation light, which has the red and green lights combined into a single lantern. To acquire the COLREG-compliant bow navigation light pole kit, please contact your Alumacraft dealer. For a list of navigable waters in different regions of the U.S., contact your local U.S. Coast Guard Unit or visit www.uscg.mil.

Personal Flotation Device (PFD)

PFDs include Type I, II, III, IV, and V flotation devices. All boats, regardless of size must carry a Type I, II, III, or V wearable PFD for each person on board or water skiing. All boats exceeding 16 ft. (4.9 m) in length must also be equipped with a Type IV throwable device.

PFDs are intended to help save lives. You and your passengers should wear a PFD whenever boating. It is especially important that children and non-swimmers wear a PFD at all times. Make certain all passengers know how to put on and properly adjust their PFDs. Also, selecting the proper type of PFD for your kind of outing helps ensure your time on the water can be the safest possible. There are four types of PFDs to wear and one type used for throwing in emergency situations.



TYPE I



TYPE II



TYPE III



TYPE IV



TYPE V HYBRID PFD
MUST BE WORN
WHEN UNDERWAY

- Type I** Most buoyant PFD and effective on all waters, especially open, rough water.
- Type II** Good for calm water near shore on most inland waters where quick rescue is likely.
- Type III** Good for most inland water applications where quick rescue is likely. Come in various styles and some are designed for water sports.
- Type IV** Intended for heavy traffic inland waters where help is always available. Designed to be thrown to a person in the water and should never be worn.
- Type V** Inflatable design for special use activities and may be used instead of a Type I, II, or III PFD if used in accordance with the approval conditions on the label and if worn when the boat is underway. Some Type V PFDs provide increased protection against hypothermia.

NOTICE

- **If a Type V PFD is to be counted toward the minimum carriage requirements, it must be worn.**
- **Special PFDs are available for skiing and other watersports. These PFDs are constructed with materials suitable for high impact falls.**

Keep the following PFD points in mind:

- Set an example and wear your PFD. Require your passengers to wear them also.
- Make sure the PFD fits properly; this is especially important for children and non-swimmers.
- At the beginning of each season, check PFDs for damage and test for proper flotation.

RECOMMENDED EQUIPMENT

As a precaution, a good boater will avoid potential problems on an outing by having additional equipment on board. Normally, this equipment is dependent on the body of water and the length of your trip. Your dealer can assist you:

- | | |
|---|--|
| • First Aid Kit and Operator's Guide | • Spare Propeller, Nut and Washer |
| • Anchor with at Least 75 Ft [23 M] of Line | • Spare Fuses |
| • Mooring Lines And Fenders | • Local Charts and Compass |
| • Bailing Device | • Waterproof Flashlight |
| (Bucket, Hand Pump, etc.) | • Portable AM/FM Radio with Weather Band |
| • Combination Oar/Boat Hook | • Spare Flashlight and Radio Batteries |
| • Day/Night Visual Distress Signal | • Sunglasses and Sun Block |
| • Lubricant | • Cellular Phone |
| • Tool Kit | |

EMERGENCIES

REPORTING

When an accident occurs, the operator of the boat is responsible for filing a report with the appropriate authorities. Generally, reports are necessary for accidents involving loss of life, injury or damage over \$200. Ask your insurance agent for specific details.

RENDERING ASSISTANCE

The United States Code, Title 46 states, *The owner or operator of a vessel is required by law to render assistance to any individual or vessel in distress, so long as his vessel is not endangered in the process.* The 1971 Boating Safety Act grants protection to a "Good Samaritan" boater offering good faith assistance, and absolves a boater from any civil liability arising from rendering assistance.

FIRES

Most fires are the result of gasoline and oil accumulating in the bilge from careless fueling practices combined with the careless use of smoking materials. If a fire should start, aim the fire extinguisher at the base of the flames using a sweeping motion. If the fire does not go out, or if there is a chance of explosion, get out immediately and swim at least 25 yd. [22.9 m] upwind from the boat and use the visual distress signals to get assistance.



KC-0162.1

On board fires involving the fuel system usually result in either an explosion that completely destroys the boat, or the boat burning to the waterline and self extinguishing. Deciding on abandoning the boat or staying to fight the fire is difficult and depends on many factors. Try to formulate a fire plan in advance so decisions can be made without hesitation in the event of a fire.

The best way to avoid fires is to refuel safely, keep ignited smoking materials away from flammables, and maintain your electrical system in its original condition.

WARNING

Gasoline will float on the water and can burn. If the boat is abandoned, swim far enough upwind to avoid fuel that may spread over the surface of the water to avoid serious injury.

CAPSIZING AND SWAMPING

A boat can become capsized or swamped when least expected by large waves or wakes coming over the bow, gunwales or stern, or by hitting something that damages the hull. Like fires, try to formulate a plan well in advance. The best way to avoid these accidents is to turn into the waves with the boat properly trimmed and avoid collisions with stationary objects in the water.

WARNING

Always anchor from the bow and never anchor from the stern in strong currents. A small current will make the boat unsteady...a strong current can pull a boat anchored by the stern under water and keep it there.

If your boat capsizes or becomes completely swamped, keep in mind the following guidelines:

- Stay away from the propeller and try to turn off the engine to prevent injury and damage.
- If others were on board, try to locate them and make sure they are conscious and can swim.
- Stay with the boat. Your Alumacraft is equipped with level flotation and will not sink.
- Do not try to swim to shore unless you are very close to land. It's usually further than it looks.
- If the boat is inverted, try to climb onto the bottom of the hull and get assistance.

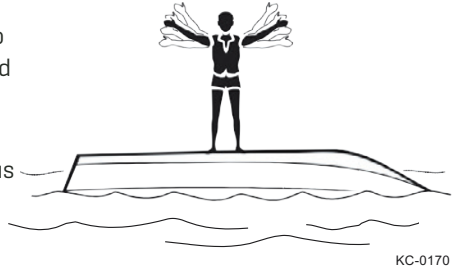

KC-0170

If you've struck something and your boat begins to take on water:

- Try to plug the leaks with cloth or any available materials.
- Run the bilge pump and bale with buckets.
- Immediately head for the nearest port or beach the boat on the nearest shore.
- If the boat eventually swamps, stay with it. It will float.

HAZARDOUS CONDITIONS

Every waterway poses hazards that you should avoid; shallow water, tree stumps, rocks, etc. Ask local boaters for information and consult a marine chart when boating on unfamiliar waters.

WEATHER

Getting caught in severe weather on a large body of water is dangerous. If navigating on such waters, your boat should be equipped with communications gear, a marine VHF-FM and/or HF transceiver as applicable to your operating area. Always check with the local weather stations, the U.S. Coast Guard, or Weather Service broadcasts for the latest conditions before venturing out.

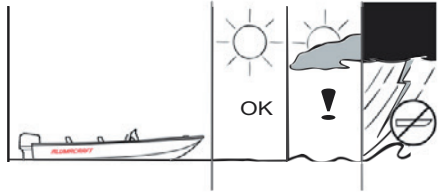

KC-0212.2

While on the water, the best way to receive timely weather information is by radio.

NOAA Weather Radio (NWR), operated by the National Weather Service, provides continuous weather programming for all U.S. waters at 162.55 or 162.40 Megahertz on your FM radio. Always monitor your communications equipment while boating so you have adequate time to seek port in the event of a storm.

If you do get trapped in bad weather, turn into the waves and proceed slowly. Keep all passengers low, near the center of the boat and make sure everyone is wearing their PFD. If you must move in the same direction of the waves to get home, try to keep on top of each wave and maintain the same speed as the wave.

DAM SPILLWAYS

The water around a dam spillway is a hazardous area. It is subject to rapid changes and must be avoided.

WEEDS

Weeds are generally a threat to your boat's engine. Weeds on the propeller may cause the engine to vibrate and can restrict water intake, causing overheating of the engine. If you run into heavy weeds, stop the engine and make sure the propeller is completely stopped. Clear the propeller and water intake completely of weeds before proceeding.

Weeds can sometimes be removed by shifting to neutral, pausing a moment, then shifting to reverse to unwind the weeds from the propeller.

SHALLOW WATER OPERATION

Operating in shallow water presents a number of hazards. Water of any depth may contain stump fields, sand bars, rocks, or other unmarked underwater hazards. If the engine strikes an underwater hazard, check for boat and engine damage. If the engine vibrates excessively after striking an underwater obstruction, it may indicate a damaged propeller.

CARBON MONOXIDE POISONING

Carbon monoxide (CO) is a colorless and odorless gas that is extremely dangerous. Even the best boat design and construction may not prevent hazardous levels of CO from accumulating. You must provide adequate air flow ventilation through the boat when operating the boat with the convertible top and/or side curtains in place. You should also pay attention to the effects caused by other vessels moored or anchored next to your boat and the effect of your exhaust on other boaters.

Sources of carbon monoxide include:

- Blockage of boat exhausts by obstruction.
- Exhausts traveling along obstruction.
- Operating at slow speed or while dead in the water.
- Operating with high bow angle.
- Exhausts from other vessels in confined areas.
- Operating with canvas tops and side curtains in place without ventilation.

To reduce CO accumulation, always ventilate the boat interior by opening the deck hatches, windows and/or canvas to allow for air flow through the boat. If you suspect someone is a victim of CO poisoning, have them breathe deeply and seek immediate medical attention.

DANGER

Carbon monoxide gas (CO) is colorless, odorless and extremely dangerous. All engines and fuel burning appliances produce CO as exhaust. Direct and prolonged exposure to CO will cause BRAIN DAMAGE or DEATH. Signs of exposure to CO include nausea, dizziness and drowsiness.

WARNING MARKERS

It is a good idea to ask local boaters and authorities if there are hazardous areas and how they are marked. Boaters must also recognize the flag designs which indicate divers are present and stay well clear of the area. Watch for swimmers, down water skiers and restricted areas. Swim areas and many underwater hazards may not be marked, especially on rural waters with little watersport activity. Always stay alert and watch for others in congested waters.



Distress flags indicate a fellow boater is in need of assistance. Navigation markers serve as a means of identifying navigable routes, and indicate water hazards.



DIVERS FLAG



USED BY
RECREATIONAL
DIVERS -
INDICATES
DIVER'S
POSITION

ALPHA FLAG



WORLDWIDE
VESSELS
ENGAGED IN
DIVING
OPERATIONS -
DOES NOT
INDICATE
DIVER'S
POSITION

KC-0372.1

SAFE OPERATING SPEED

Maneuvering speed is the maximum speed at which you can make sudden turns without risking loss of boat control. This speed depends on weather and water conditions, and how the boat handles. Like automobiles, each boat handles a little differently and the method by which the boat is steered, whether tiller controlled or steered at a console will make a difference. There are also minimum safe speeds for certain conditions. In high winds, it may be necessary increase speed to maintain headway or to keep the bow of the boat up to prevent waves from breaking over it. Careful experimentation with your boat in various conditions will help you learn the safe operating speed for your particular boat.

GENERAL PRECAUTIONS

As operator of your Alumacraft boat, your safety and that of your passengers and other boaters is your responsibility. Please use the following general precautions each time you use your boat:

- Provide and use all required safety equipment.
- Make sure all children and nonswimming passengers wear their PFDs and all other passengers have ready access to them.
- Make sure all persons are properly seated before moving the boat.
- Make sure you load passengers and gear safely, distributing all loads evenly.
- Know the maximum weight capacity and horsepower rating for your boat, and do not exceed these limits.
- Refuel safely as described in *Section 4 - Getting Underway*.
- If you are on "Big Water" be sure someone on shore knows where you plan to be.
- Do not risk boating in storms or when storms are forecast.
- Always attach the emergency shut-off lanyard to the operator before starting the gasoline engine.
- Always stay alert when underway and keep one hand on the steering mechanism and one hand on the throttle. Never let go of the steering control.
- Know the nautical rules as described in *Section 2 - Rules of the Road* in this operator's guide.
- Learn to anchor and dock properly as described in *Section 4 - Getting Underway*.
- At night, use navigation lights and travel at slower speeds.
- Never operate your boat while under the influence of alcohol or other drugs.

WARNING

Never operate or allow another person to operate the boat while under the influence of drugs or alcohol. Operation while under the influence of such substances is a violation of Federal law.

FOAM FLOTATION

Boats built after July 31, 1973 are required to meet applicable U.S. Coast Guard standards for flotation. It becomes necessary to remove foam flotation material for repairs or modification. It is important that the flotation be re-installed in its original position.

WARNING

When replacing flotation foam, use only gasoline resistant foam of equivalent density and quantity to that originally provided. Use of insufficient or sub-standard replacement foam could be dangerous.

MORE ABOUT BOATING

The more you learn about boating, the more fun you will have and the safer you will be on your new Alumacraft. The following is a listing of some of the agencies and organizations that provide free boating classes and information.

- American Boat and Yacht Council (ABYC)
- American Red Cross
- U.S. Coast Guard Auxiliary
- National Fishing and Wildlife Foundation
- U.S. Power Squadrons
- State Boating Offices
- Sport Fishing Institute

U.S. nautical charts can be purchased throughout the country at Government Printing Office stores and through agents. Please visit <https://www.charts.noaa.gov/InteractiveCatalog/nrnc.shtml> for additional information.

Some of the federal agencies that publish recreational maps include the U.S. Army Corps of Engineers, the U.S. Forest Service, the National Park Service and the Tennessee Valley Authority. In addition, you can get a free listing all state boating agencies by visiting <https://www.nmma.org/>

THE ENVIRONMENT

As a boater, you already appreciate nature's beauty and the peace of the great outdoors. It is a boater's responsibility to protect the natural environment by keeping waterways clean.

Don't put anything in the water you wouldn't want to eat or drink!

CONSERVE FISHERY RESOURCES

There is a tremendous drain on our fishery resources. Over-fishing and pollution have strained the fish population. Do your part by keeping only what you will eat by practicing catch-and-release.

FOREIGN SPECIES

If you trailer your boat from lake to lake, you may unknowingly introduce a foreign aquatic species from one lake to the next. Thoroughly clean the boat below the water line, remove all weeds and algae, and drain the bilge and livewells before launching the boat in a new body of water. See the Aquatic Invasive Species (AIS) section for further information.

FUEL AND OIL SPILLAGE

The spilling of fuel or oil into our waterways contaminates the environment and is dangerous to wildlife. Never discharge or dispose fuel or oil into the water; it is prohibited and you could be fined. There are two common, accidental types of discharge:

- Overfilling the fuel tank
- Pumping contaminated bilge water

WARNING

Fumes from rags can collect in bilge and be extremely hazardous. Never store rags used to wipe up fuel or solvent spills in the boat. Dispose of rags properly ashore.

DISCHARGE AND DISPOSAL OF WASTE

Waste means all forms of garbage, plastics, recyclables, food, wood, detergents, sewerage and even fish parts in certain waters - in short, nearly everything. We recommend you bring back everything you take out with you for proper disposal ashore.

If you have a marine sanitation device [head or marine toilet] installed, use an approved pump-out facility at your marina. Many areas prohibit the discharge of sewerage overboard or even an operable overboard waste discharge.

EXCESSIVE NOISE

Noise means engine noise, radio noise or even yelling. Many bodies of water have adopted noise limits. Don't use thru-transom exhaust unless you're well off shore. Music and loud conversation can carry a considerable distance on water, especially at night.

WAKE AND WASH

Be alert for NO WAKE zones. You may be responsible for any damage or injury caused by your wake/wash. Prior to entering a NO WAKE zone, come off plane to the slowest steerable speed.

EXHAUST EMISSIONS

Increased exhaust emissions pollute our water and air. Keep your engine tuned and boat hull clean for peak performance. Consult your dealer and engine manual for information.

PAINTS

If your boat is kept in water where marine growth is a problem, the use of antifouling paint may reduce the growth rate. Be aware of environmental regulations that may govern your paint choice. Contact your local boating authorities for information.

CLEANING AGENTS

Household cleaners should be used sparingly and not discharged into waterways. Never mix cleaners and be sure to use plenty of ventilation in enclosed areas. DO NOT use products which contain phosphates, chlorine, solvents, non-biodegradable or petroleum based products. Citrus based cleaners are excellent for marine cleaning purposes and are safe for you and the environment. Refer to MAINTENANCE for more information.

AQUATIC INVASIVE SPECIES (AIS)

Aquatic Invasive Species [AIS] are non-native plant or animal species that threaten the diversity or abundance of the native species. They also threaten the natural ecology of the body of water they infest. AIS almost always have a negative impact on the waterway, its native species, and recreational or commercial activities on the waterway.

Common examples of AIS are; Eurasian watermilfoil, hydrilla, sea lampreys, zebra mussels, Asian carp, and gobies. Many other examples of AIS exist throughout the world's waterways.

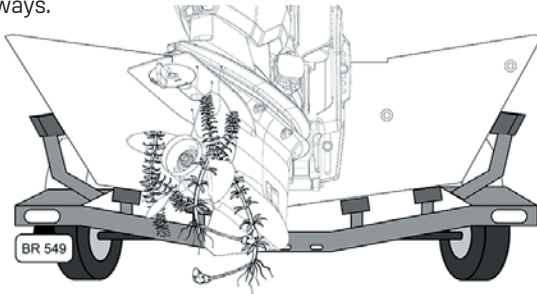

A typical factor in AIS infestations is that the non-native species are introduced by human activity. Some AIS are introduced by commercial operations; however AIS can be introduced through recreational boating activities. The transportation of recreational boats and water sports equipment between waterways can be a major factor in the spread of AIS.

Small pieces of plants or animals hanging from a propeller, trailer or wakeboard can transfer enough biological material to establish an AIS in a new waterway. The early reproductive stages of many AIS are microscopic; small amounts of water in a bilge, live well, cooler or trapped in a compartment can contain enough organisms to establish an infestation.

As responsible boat owners we MUST do our part to prevent the spread of these aquatic hitchhikers. Check your boat each time you leave the water! In many cases it is required by law, be sure to check the local regulations for the waterways where you boat.

CLEAN, DRAIN & DRY - EVERYTHING, EVERY TIME! Before you leave a waterway, follow the procedure below to help prevent the spread of AIS.

CLEAN! Inspect and remove any visible mud, aquatic plants, fish or animals from the boat, trailer and any water sports equipment before transporting your equipment.

DRAIN! Remove all water from the boat, including ballast, bilge, livewell, engine and gearcase. Dispose of unwanted live bait in the trash.

DRY! Allow the boat to completely dry before visiting any other bodies of water.

AIS INSPECTION CHECKLIST

Use the following checklist as a guide when inspection for AIS.

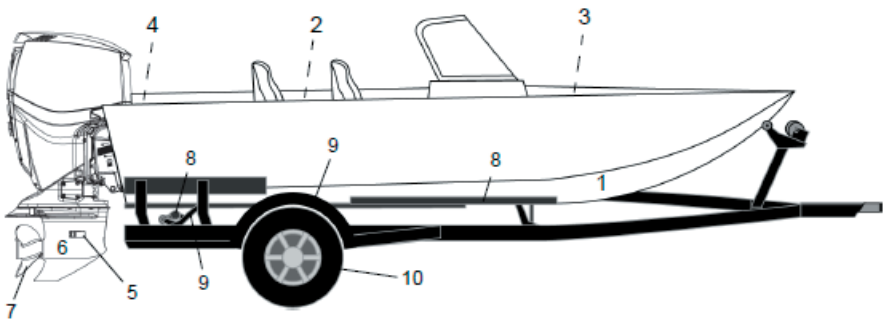

INSPECTION ITEMS - BOAT	REF. #	COMPLETE [✓]
Hull	1	
Floor	2	
Live Well	3	
Transom Well	4	
Water Inlet and Outlet Fittings		
Anchors and Lines		
Boarding Ladder		
Transducers and other Attachments to the Hull		
INSPECTION ITEMS - ACCESSORIES	REF. #	COMPLETE [✓]
Fishing Tackle and Fishing Lines		
Bait Buckets		
Landing Nets		
Water Sports Equipment (Skis, Wakeboards, etc.)		
Tow Ropes		
INSPECTION ITEMS - OUTBOARD [S]	REF. #	COMPLETE [✓]
Water Intake Screens	5	
Gearcase	6	
Propeller	7	
INSPECTION ITEMS - TRAILER	REF. #	COMPLETE [✓]
Bunks and/or Rollers	8	
Fenders and Frame	9	
Tire and Wheels (including spare tire)	10	
License Plate and Brackers		
Lights and Wiring		

COMPLIANCE LABELS

[The following images are merely examples of labels and may differ depending on the model and model year]

Several compliance labels are affixed to the vessel to demonstrate compliance with Federal boating and/or emissions standards. These labels may include the United States Coast Guard Capacity Plate, Canadian Compliance Notice, California Air Resources Board Certification Label, United States Environmental Protection Agency, the European Union CE mark, and the United Kingdom UKCA compliance mark. These various labels are affixed to the boat, as applicable, and must not be altered or modified in any way. Federal laws require these labels to remain installed on the vessel. If these applicable labels are damaged, they must be replaced immediately by contacting your local Alumacraft dealer.



Example of United States Coast Guard Capacity Plate

Example of Canadian Compliance Notice for Boats

The United States Coast Guard capacity plate lists the approved number of persons, maximum weight, and maximum horsepower for a given vessel. Under the U.S. Coast Guard Federal Boat Safety Act of 1971, boats less than 20 feet powered with an inboard, outboard, or stern drive engine manufactured after November 1, 1972, must display a capacity plate defining the safe load limits. This plate must be mounted where you can see it when preparing to get underway. Capacity plates should never be removed, altered, or tampered with.

Many states have statutes prohibiting the carriage of people and gear in excess of the stated capacity or the installation of a motor that exceeds the recommended horsepower limit. Additionally, you may void your insurance policy if you are found to have exceeded the limits stated on your capacity plate.

The Canadian Compliance Notice is a statement from the manufacturer or importer that a vessel is built according to the construction requirements of the Small Vessel Regulations. The Small Vessel Regulations require, with a few exceptions, all pleasure craft of less than 24 meters, and as of April 29, 2011, all non-pleasure vessels of not more than 15 gross tonnage, that are or can be fitted with engine[s] to have a Compliance Notice affixed to them in a conspicuous position plainly visible from the helm. By law, the Compliance Notice must be permanently affixed to the pleasure craft.

CALIFORNIA AIR RESOURCES BOARD [CARB] EMISSION CONTROL SYSTEM INFORMATION

The Spark-Ignition Marine Engine and Watercraft regulations cover any spark-ignited engine that is used to propel a marine watercraft, including personal watercraft, outboard engines, and sterndrive/inboard [e.g. propeller driven vessels, jet boats, air boats, hovercraft] engines. The California Emission Control System Information label provides compliance information regarding evaporative emissions from the vessel's fuel system. The label includes the evaporative family name, model year, manufacturer, and the emissions control system type. This label is required for any new boat offered for sale in the state of California.

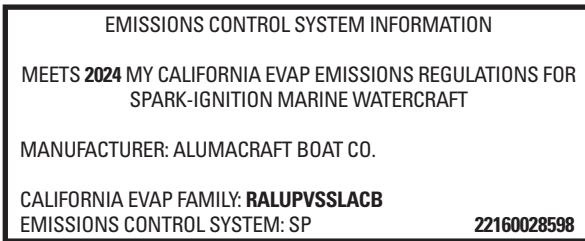

EUROPEAN UNION BUILDER'S PLATE

The EU directive 2013/53/EU on recreational craft sets minimum requirements for the trade of boats, personal watercrafts, marine engines, and components. The directive sets out minimum safety and environmental requirements for boats between 2.5m-24m and personal watercraft, which guarantee their suitability for sale or use in Europe. For boats used in the European Union, each boat must contain a permanently affixed builder's plate, which is mounted separately to the Craft Identification Number. An example is shown below.

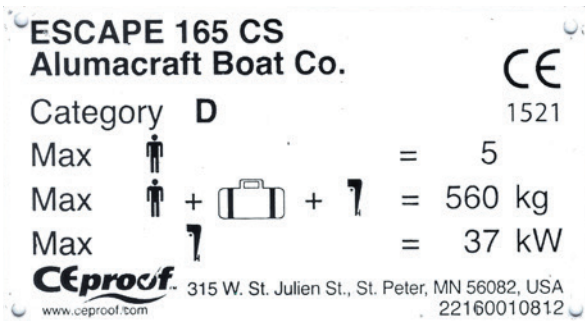

EUROPEAN UNION CE CERTIFICATION MARK AND UNITED KINGDOM (UKCA) COMPLIANCE MARK

The letters 'CE' appear on many products traded on the extended Single Market in the European Economic Area (EEA). They signify that products sold in the EEA have been assessed to meet high safety, health, and environmental protection requirements. By affixing the CE marking to a product, a manufacturer declares that the product meets all the legal requirements for CE marking and can be sold throughout the EEA. This also applies to products made in other countries that are sold in the EEA.

The United Kingdom Conformity Assessment (UKCA) mark is a new UK product marking that will be required for certain goods sold in Great Britain (England, Wales, and Scotland). It applies to most goods that previously required the CE mark.



CALIFORNIA PROPOSITION 65 HANGTAG

The California Proposition 65 also known as the Safe Drinking Water and Toxic Enforcement Act of 1986 requires a variety of specific consumer warnings to be placed on products to notify consumers of potential exposure to certain chemicals the State of California identifies as cancer-causing or causing reproductive harm. Any vessels sold in the state of California are required to display a proposition 65 hangtag with specific boat related information for consumers.

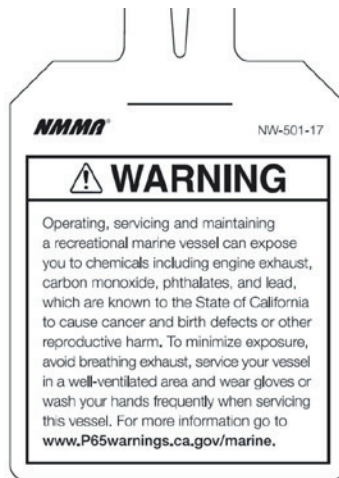

SECTION 2: RULES OF THE ROAD

NOTICE

The nautical rules of the road must be followed to prevent collisions between vessels. Like traffic laws for automobiles, the operator is legally required to follow the rules.

AIDS TO NAVIGATION

The following information outlines only the most basic of the nautical rules of the road. For more information, contact your local U.S. Coast Guard Auxiliary. Learn to recognize the different buoys and day markers; they are the signposts of the waterway. There are two primary marking systems in use in the U.S.; the Uniform State Waterway Marking System [USWMS] used on inland waters and maintained by each state, and the Federal Waterways Marking System [FWMS] used on coastal waters and rivers and maintained by the U.S. Coast Guard [USCG]. In addition, the FWMS has two modified systems; Western River Buoyage, and Intracoastal Waterway Buoyage. Be sure to check with local authorities on the buoyage system in use. The type of hazard/warning buoys and markers depend on the area of jurisdiction. Check with local boating authorities.

USWMS SYSTEM

In the USWMS Lateral System, well defined channels are marked with red and black buoys. Lateral means the sides of the channel are marked and the boat should pass between them. The USWMS Cardinal System is used when there is no well defined channel or where an obstruction may be approached from more than one direction. With the cardinal system:

- Pass north or east of BLACK-TOPPED WHITE buoy.
- Pass south or west of RED-TOPPED WHITE buoy.
- RED and WHITE VERTICALLY STRIPED buoy indicates boat should pass outside of the buoy [away from shore].

UNIFORM STATE REGULATORY MARKERS

USWMS regulatory markers are white with international orange geometric shapes; you must obey regulatory markers.

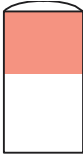

NAVIGATE TO
SOUTH OR WEST



NAVIGATE TO
NORTH OR EAST

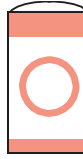

CONTROLLED
AREA

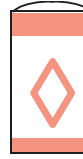

DANGER



NAVIGATE TO
STARBOARD
FACINGUPSTREAM

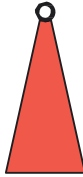

NAVIGATE TO
PORT FACING
UPSTREAM



DO NOT PASS
BETWEEN SHORE
AND BUOY



SPECIAL
PURPOSE



MID-CHANNEL



BOATS
KEEP OUT



INFORMATION

KC-0411.2

KC-0411.3

FWMS SYSTEM

The FWMS Lateral System is for use on navigable waters except Western Rivers and Intracoastal Waterways. The markings on these buoys are oriented from the perspective of being entered from seaward [the boater is going towards the port]. This means that red buoys are passed on the starboard [right] side when proceeding from open water into port, and black buoys are to port [left] side.

The right side [starboard] of the channel is marked with RED, even numbered buoys. The left [port] side of the channel is marked with GREEN, odd numbered buoys.



The middle of the channel is marked with RED and WHITE vertically striped buoys; pass close to these buoys.



Obstructions, channel junctions, etc. are marked with RED and GREEN horizontally striped buoys.

A RED band at the top means the preferred channel is to the left of the buoy; a GREEN top band means the preferred channel is to the right of the buoy.

Day markers are colored and numbered the same as buoys. RED, triangular day markers with even numbers mark the starboard side of the channel. GREEN, square day markers with odd numbers mark the port side of the channel.



Lights, bells and horns are used on buoys for night or poor visibility conditions.

RIGHT-OF-WAY

NOTICE

In general, boats with less maneuverability or boats that are not powered, or are powered by sail have the have right-of-way over more agile craft. Likewise smaller boats should give way also. You must stay clear of the vessel with right-of-way and pass to his stern.

PRIVILEGED BOATS

Privileged boats have right-of-way and can hold course and speed. Sailboats and boats paddled or rowed have the right-of-way over motor boats. Sailboats under power are considered motorboats. Small pleasure craft must yield to large commercial boats in narrow channels.

BURDENED BOATS

The burdened boat is the boat that must make whatever adjustments to course and speed necessary to keep out of the way of the privileged boat.

CROSSING SITUATION

In crossing situations, the boat to the right from the 12 o'clock to the 4 o'clock position has the right-of-way. It must hold course and speed. The burdened boat keeps clear and passes behind the privileged boat. Boats going up and down a river have the privilege over boats crossing the river.

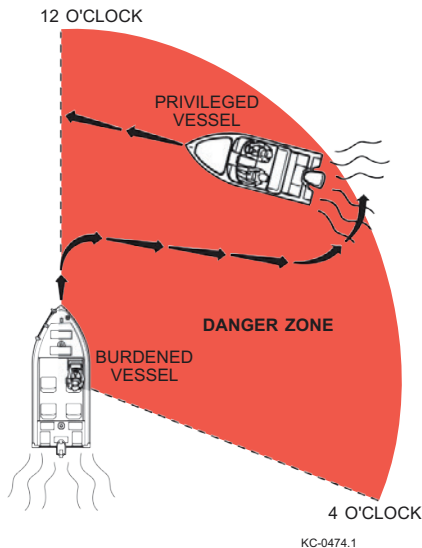

MEETING HEAD-ON

Neither boat has the right-of-way in this situation. Both boats should decrease speed, should turn to the right, and pass port-to-port. However, if both boats are on the left side of a channel, each vessel should sound two short horn blasts and pass starboard to starboard.

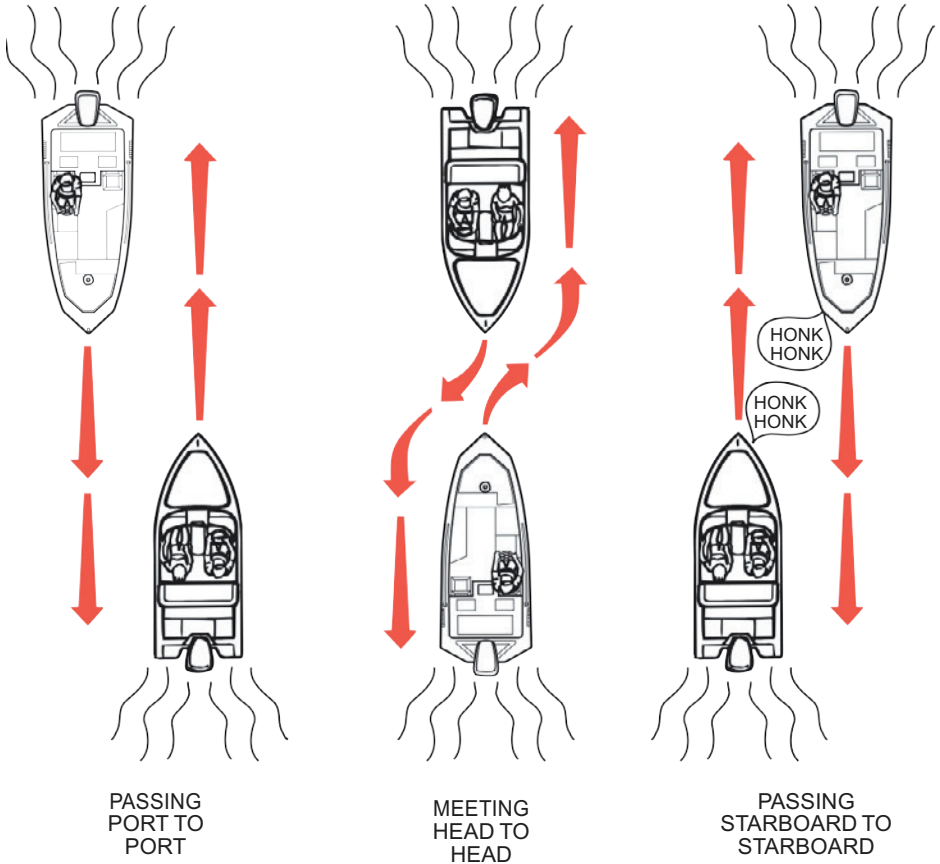

KC-0584

OVERTAKING

In overtaking situations, the boat being passed has the right-of-way, and the passing boat is required to stay clear.

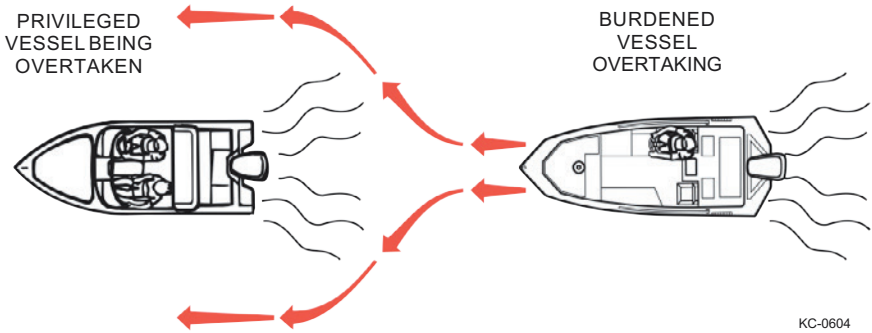

THE GENERAL PRUDENTIAL RULE

The general prudential rule regarding right-of-way is that if a collision appears unavoidable, neither boat has right-of-way. Both boats must act to avoid collision.

NIGHT RUNNING

Boats operating between sunset and sunrise [hours vary by state] must use navigational lights. Nighttime operation, especially during bad weather or fog can be dangerous. All Rules of Road apply at night, but it is best to slow down and stay clear of all boats, regardless of who has right-of-way. Protect your night vision by avoiding bright lights and have a passenger, if possible, help keep watch for other boats, water hazards, and aids to navigation. The size, speed and direction of other vessels are determined at night from the running lights. A green light indicates the starboard side of a boat and a red light indicates the port side. Generally if you see a green light, you have the right-of-way; if you see a red light, give way to the vessel. A spotlight or flashlight is recommended to help identify buoys and hazards such as stumps and rocks.

SECTION 3: SYSTEMS AND COMPONENTS

PROPELLERS

The propeller converts the engine's power into the thrust needed to propel the boat. Care and selection of your propeller is very important to proper boat operation. Propellers are identified by two numbers, such as 13 x 19, and a material identification, such as aluminum or stainless steel. In the number sequence, the first number is the diameter of the propeller and the second is the pitch.

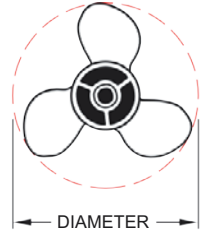

KC-1580.1

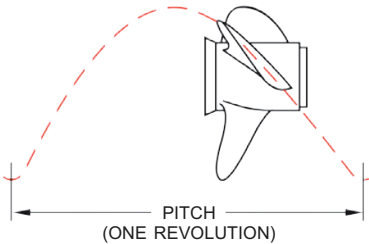

KC-1581.1

Pitch is the angle of the blades expressed in the theoretical distance a propeller travels in each revolution. In the above example, the pitch is 19, or each revolution of the propeller pushes the boat 19 in. [48.3 cm] through the water.

Keep these guidelines in mind when selecting a propeller:

- There are many different propeller designs for specific operating characteristics, including the number of blades, relief holes, cupping, etc. Do not attempt to change propellers until after you have a chance to determine your average load and individual requirements. Your dealer is best qualified to help you select a propeller.
- Engine RPM must be within the recommended operating range. Refer to the engine operator's manual, and see Tachometer, found later in this section.
- Higher propeller pitch reduces: RPM power, acceleration, engine noise, and usually improves fuel economy and top speed.
- Lower propeller pitch increases: RPM power, acceleration, engine noise, reduces fuel economy and top speed.

⚠ WARNING

Before installing or removing the propeller:

- **Put the remote control in the NEUTRAL position.**
- **Put the main switch in the off position and remove the key.**

A smaller pitch propeller should be selected for water skiing or for heavy loads. A smaller pitch propeller will develop more thrust for faster planing. A higher pitch propeller should be selected if full throttle RPM exceeds the maximum recommended range. See Tachometer, discussed later in this section.

⚠ WARNING

DO NOT use your hand to hold the propeller when loosening the nut. You could be seriously injured. Put a wood block between the cavitation plate and the propeller blade to prevent the propeller from turning.

ELECTRICAL SYSTEM

Your Alumacraft is equipped with a 12 volt [V], negative ground DC electrical system. In the 12V setup, a single 12V battery supplies all electrical power. The red positive wire is hot and the black negative wire is ground. With the addition of an optional trolling motor battery, one battery is used for engine cranking and systems power, and the other exclusively for the trolling motor.

The cranking or starting battery is recharged by the alternator when the engine is operating. The batteries supply power to the electrical system through the fuse panel. The trolling motor batteries are not connected in any way to the cranking battery. Trolling motor batteries must be recharged with a battery charger on shore as described in *Section 6 - Maintenance and Storage*.

CONSOLE INSTRUMENTS

SPEEDOMETER

Your boat's speedometer registers forward boat speed in miles per hour [mph] and kilometers per hour [km/h]. Generally it will not register under 10 mph (16 km/h), and at maximum speed there may be a slight speed fluctuation indicated. These are normal functions since most marine speedometers operate with water pressure.

The speedometer is useful to find the best trim setting and can be used in conjunction with the tachometer to determine the best propeller pitch for your motor.



TACHOMETER

This gauge registers motor speed in revolutions per minute (RPM). Use this gauge to keep the motor within proper operating range. Knowing the RPM at which your motor is running is also useful for determining the proper trim setting, and for choosing the correct propeller, when used in conjunction with the speedometer.

To determine if you have the correct propeller by using your tachometer as a guide, first consult your engine owner's manual for your outboard's optimum RPM range (e.g., 4800 to 5500 RPM). This is the acceptable RPM range with the outboard operating at wide open throttle. If the engine is operating below this range, it is not delivering its best performance. Operation of the engine above this range could result in serious engine damage. Your dealer can assist you in selecting a propeller that is safe for your outboard and matches your specific performance needs.

If your motor is equipped with a power trim and tilt unit, you can also fine tune the best motor trim range by using the tachometer and speedometer. Once on plane and at a steady throttle, trim the motor up slowly until the maximum speed is reached for that throttle setting. If you trim up too far, the tachometer speed will increase and the speed will decrease.



VOLTMETER

The voltmeter indicates the voltage of the main or cranking battery in volts [V] DC. With the ignition on and the motor not running, the gauge should read just above 12 V. The gauge should register much higher than 12 V when the engine is running at high RPM. This indicates it is charging properly. If the gauge operates in either red area [too high or too low], contact your dealer for assistance.



TRIM GAUGE [option]

This gauge measures the outboard drive unit tilt and indicates the relative position of the bow, up or down, when the boat is on plane. Use this gauge to monitor boat trim. You may wish to refer to your engine owner's manual for further details.



FUEL GAUGE

On models with a permanently mounted fuel tank, this gauge registers fuel level in the tank by receiving electrical signals from the fuel sending unit located at the rear of the tank. The ignition switch must be in the RUN position to activate the gauge. Most fuel tanks in Alumacraft boats are long, shallow tanks. You only get accurate readings when boat is on full plane and running as level as possible.



CONTROLS

SHIFT/THROTTLE CONTROL

The shift/throttle control on your boat differs from model to model and may depend on the particular outboard mounted on your Alumacraft. The following control is typical of the operation of most controls. Be sure to consult the engine or control manual for specific operational information.

NOTICE

To avoid potential engine damage, do not shift too quickly from forward to reverse. Stay in neutral, or idle position until the boat has lost most of its headway before completing the shift to reverse.

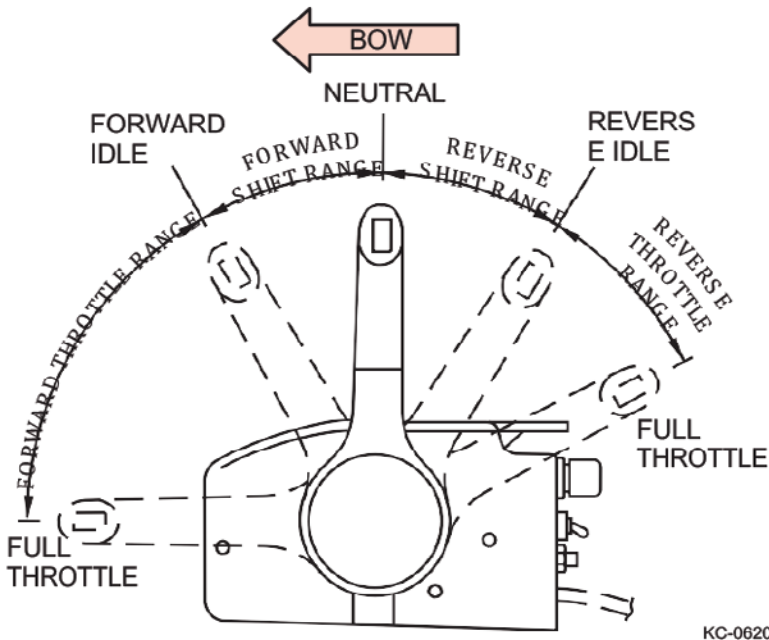

This one-hand, single lever control operates as both a gear shifter and a throttle. The lever automatically locks in the neutral [straight up and down] position for safety when starting. The lever can only be moved from neutral by pressing the neutral lock release button. Shifting is accomplished by moving the lever into the first 15° of travel; push the lever for forward, and pull the lever back for reverse. By advancing the lever beyond 15°, you move from the shifting range to the throttle range.

Be sure to consult the engine or control operator's manual.

TRIM SWITCH

If your boat is equipped with power trim and tilt, this switch activates that function. Depending on model, your boat may have up to three trim switches. All boats with power trim have at least one trim switch which is located on the shift/throttle control. Boats equipped with a bow power panel have a trim switch on the panel for convenient control of the outboard from the bow seat. In addition, some Alumacraft bass boats have a trim switch located at the stern for adjusting the motor angle prior to trailering the boat.

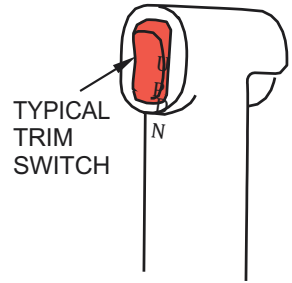

KC-0931

While monitoring the trim gauge, activate the trim and tilt function by pushing and holding the trim switch until the motor is at the desired angle.

BILGE SWITCH

The bilge pump switch, located at the dashboard or control panel, activates the bilge pump to remove excess water from the bottom of the boat. To operate the pump, turn the switch on. If water exists in the bilge, you will notice a stream of water being pumped out of the outlet at the side of the boat. Leave the bilge pump running until all water is removed, then turn it off. Note that some boats are equipped with an automatic bilge pump switch.

To avoid damaging the pump, always remember to turn off the bilge pump when not in use.

NOTICE

Be sure to switch the bilge pump off when not in use. Running the pump when the bilge is dry drains the battery and will damage the pump.

SAFETY AND FUNCTIONAL FEATURES

NAVIGATION LIGHTS

Most models are equipped with stowable navigation lights. These lights are required whenever your boat is operated after sunset. The navigation lights switch is located on the dashboard or control panel and controls both the running and anchor lights. Both lights comply with all Coast Guard regulations.

If you will be moving under power, place the switch in the NAV position to turn on the red/green running light at the bow of the boat and the white anchor light at the stern. The gauge lights are also illuminated when the switch is in the NAV position. The ANC position turns on only the white anchor light at the stern of the boat for night anchoring.

NOTICE

Operation of the boat between sunset and sunrise with the switch in the anchor light position is illegal and may be hazardous. Running lights are required to indicate direction and right-of-way at night.

To mount a plug-in pole navigation light, open the outlet cover 1/4 turn. Align the light connector with the outlet and insert the light mast. The lights will only go in one way so do not force them. Make sure the light is fully seated, and then completely open the cover another 1/4 turn to lock the light in place.

HORN

If your boat has a horn, it satisfies the Coast Guard requirement for an audible signaling device and is designed for marine use. The horn can be sounded by pressing the red HORN button or turning the horn switch clockwise, that is located in the console or the switch panel located in the off section of the boat on tiller models. Some models are wired for a horn but the horn is not included as standard equipment. Use the horn to alert other boats of your presence, and to alert lift bridge or lock operators of your intentions.

DRAIN PLUG

The drain plug is located on the lowest part of the transom (the bilge) below the floor cutout. It is important to remove the plug after each use to be sure no water remains in the bilge. Water confined in the bilge can lead to fungal growth and deterioration of the boat floor. The plug should also be removed when storing the boat outside, whether or not the cover is installed, and when trailering the boat in the rain. Always raise the bow of the boat to ensure full drainage of the hull.

CAUTION

To avoid flooding, replace the drain plug before putting the boat in the water. If you do forget to replace it prior to launching, replace it immediately and operate the bilge pump to remove the excess water.

DECK HARDWARE

Most Alumacraft boats are equipped with four cleats. Use these cleats for tying lines when docking. Never use the cleats to lift the boat under any circumstances. If tying up your boat for extended periods of time, use the stainless steel eyes located on the bow and stern.

EMERGENCY SHUT-OFF SWITCH AND LANYARD

The emergency shut-off switch and lanyard are designed to stop the engine in the event the boat operator is thrown overboard or forced away from the helm. Attach the lanyard to the operator whenever the boat is running. If the operator is thrown

from the seat or moves too far from the helm, the lanyard will engage the switch and shut off the engine.

To attach the lanyard, hold out the button head and slide the fork beneath the safety switch. Attach the hook on the opposite end of the lanyard to the operator's wrist or a strong piece of clothing on the operator, such as a belt.

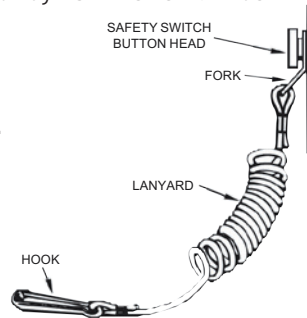

WARNING

Attach the emergency shut-off switch lanyard to the operator before starting the engine. This will prevent the boat from becoming a runaway if you are accidentally thrown from the boat. The shut-off switch can only be effective when it is in good working condition. Observe the following:

- **Never remove or modify the shut-off switch and/or lanyard.**
- **Lanyard must always be free from obstructions that could interfere with its operation.**

Once a month: Check switch for proper operation. With engine running, pull lanyard. If engine does not stop, see your dealer for switch replacement.

United States Federal Law requires the use of an emergency shut-off switch lanyard.

HANDRAILS AND HANDHOLDS

Most models provide handholds and/or handrails for traveling at speeds above 5 mph [8 km/h]. These devices are designed for your safety and should be used when the boat is operated above this speed. Some open hull fishing boats do not provide handrails or handholds. On such models, hold on to the outside gunwales when moving at speeds above 5 mph [8 km/h].

REBOARDING MEANS

WARNING

Do not attempt to reboard while the engine is running. Swimmers must not exit or enter the boat when the engine is running or the propeller is in motion.

REBOARDING PRECAUTIONS

- While these reboarding instructions are intended to be achievable by the average person, individual physical limitations may require the use of alternative means of emergency reboarding.
- If your boat is equipped with a reboarding ladder, removal of, alterations to, or disabling of this ladder requires that the owner provide other suitable means for reboarding.
- Use of optional equipment that interferes with reboarding as described in these instructions requires that the owner provide other suitable means for reboarding.

MEANS OF REBOARDING

- If your boat is equipped with a reboarding ladder, the ladder qualifies as the emergency means of reboarding.
- If your boat is not equipped with a reboarding ladder, emergency reboarding is accomplished by climbing over the transom (a.k.a. stern, aft, or rear) of the boat
- If your boat is a tunnel model with a 27-inch transom emergency reboarding is accomplished by climbing over the port or starboard side (a.k.a. left or right) of the boat.

Telescoping Ladders

1. During the reboarding process the outboard engine should not be running.
2. Approach the ladder from the outboard side of the ladder and stay clear of the telescoping portion of the ladder as it is being deployed.
3. The telescoping portion of the ladder is held in the stored position by plastic clips. Pulling the telescoping portion away from the transom deploys the ladder. Lower the telescoping portion carefully to avoid injury.
4. The sections of the telescoping ladder are held in place by an elastic cord. To extend the ladder move the elastic cord to the side of the ladder and extend the telescoping rungs.
5. Once the ladder is safely deployed, climb the ladder, and reboard the boat.



Flip-Down Ladders

1. During the reboarding process the outboard engine should not be running.
2. Approach the ladder from the outboard side of the ladder and stay clear of the flip-down portion of the ladder as it is being deployed.
3. The flip-down portion of the ladder is held in the stored position by plastic clips. Pulling the flip-down portion away from the ladder frame deploys the bvladder. Lower the flip-down portion carefully to avoid injury.
4. Once the ladder is safely deployed, climb the ladder, and reboard the boat.



Other Types Of Ladders

1. During the reboarding process the outboard engine should not be running.
2. Approach the ladder and stay clear of the ladder as it is being deployed.
3. Deploy the ladder per the ladder manufacturer's instructions.
4. Once the ladder is safely deployed, climb the ladder, and reboard the boat.

No Ladder - Transom Reboarding

1. During the reboarding process the outboard engine should not be running.
2. Approach the transom [a.k.a. stern, aft, or rear] of the boat and grab the transom edge, end cap or other available surface.
3. Apply your weight to the transom to lower its level.
4. Allow your upper body to fall forward into the boat.
5. Bring your legs around into the boat.

No Ladder - Side Reboarding [27-Inch Transom Modified-V Hulls Only]

1. During the reboarding process the outboard engine should not be.
2. Approach the boat from either the port or starboard side [a.k.a. left or right] of the boat and grab the gunnel edge.
3. Apply your weight to the gunnel to lower its level.
4. Allow your upper body to fall forward into the boat.
5. Bring your legs around into the boat.

COMFORT AND CONVENIENCE FEATURES

PEDESTAL SEATS

WARNING

Never sit on the bow or stern casting seats when the engine is running. Passengers using seats on high platform locations while running above trolling speed could be thrown overboard, resulting in injury or death. Platform seats in the bow will restrict the driver's view and must be removed during operation.

The pedestal seats in most Alumacraft boats use a column and base mechanism which allows them to be easily removed or moved to a different location in the boat. To remove a pedestal seat, simply squeeze the plastic tab that is locked in the groove on the seat base and lift the column upward. To install a seat, place the plastic into the opening in the seat base, aligning the lock tab with the groove in the base. Push down on the seat until the lock tab is firmly seated in the groove.

Adjustable pedestal seats may be raised or lowered by loosening the lower adjustment knob on the column and extending or shortening the column to the desired length and retightening the adjustment knob. Do not over-extend the column. The upper adjustment knob can be loosened so that the seat swivels but should always be tightened when the boat is underway. The pedestal seats in most Alumacraft boats use a locking pin and lever to lock the seat in the forward position. **DO NOT** unlock the seat when running the boat at trolling speeds over 5 mph. Driver and/or passengers could be thrown overboard resulting in serious injury or death.

WARNING

Center seat position is not designed to be occupied when boat is operated at speeds above 5 mph. Hand holds are not provided. Avoid serious or fatal injury due to being thrown out of seat.

Standard and optional "power pedestal" seats contain a nitrogen gas-filled steel cylinder that allows the seats to be adjusted pneumatically. These seats are adjusted by pressing on the adjustment handle and letting the seat rise, or sitting on it to lower it. Releasing the handle locks the seat at the desired height.

WARNING

The power pedestal seat cylinder is under high pressure. To avoid severe injury or death, never attempt to disassemble or tamper with the cylinder in any way.

WARNING

Never relocate a seat base. Seat bases must be mounted to the floor of the boat with a backing plate. Without a backing plate, the seat could pull out which can cause severe injury or death.

Some models are equipped with pin pedestal seats that are moved by simply pulling up and removing the seat and then the seat column. Use a single short seat column when a sitting height is desired. When the boat is to be trailered or operated above trolling speed, the pedestal seat columns must be removed from the bow and stern casting platforms and stowed to prevent obstruction of the driver's view. The seats will fit into the floor mounts without columns, keeping the seats at floor level.

STORAGE COMPARTMENTS

WARNING

To avoid the risk of fume build-up and/or spontaneous combustion, check all compartments for labeling. Most are not properly vented for fuel storage.

Various storage compartments may exist in your Alumacraft boat. Some models have lockable storage and rod storage compartments. The locks on all these compartments open with the same key. Boats with glove boxes have a separate key for this compartment.

Most models provide dry storage areas and some have dry storage compartments that double as insulated ice chests. Since these compartments are very effective at keeping moisture out, they are also efficient at keeping moisture in. If you leave something wet or damp in one of these compartments it will probably become moldy. Remember to remove such items after each outing and prop open all wet compartments until fully dry.

Some models are equipped with a compartment for locking up valuable electronic gear such as fish locators and GPS units when not in use. On tiller models, you may wish to permanently mount and wire certain electronic accessories in this compartment.

The tackle trays found on most models are handy for storing fishing lures, hooks and other tackle. The trays are removable for cleaning and some have snap lids which allows them to be used as tackle boxes at your fishing station. Remember to close all trays and storage compartments before making high speed runs.

On boats designed with a splashwell, the transom curtain or stern sliding panels separate the boat's interior from the area under the splashwell. This area can also be used for storage but keep the bilge area open.

ACCESS PORTS

Your boat may be equipped with round, sealed ports which provide access to bilge areas and fuel sending units. To remove the port cover, remove the Phillips retaining screws (if used) and then use a flat blade screwdriver to pry the cover off.

INTERIOR LIGHTS/LIVEWELL LIGHTS

Most models are also equipped with interior courtesy and livewell lights. All of our interior courtesy and livewell lights are controlled at the console. Remember that the battery will discharge if the motor is not running and the lights are turned on.

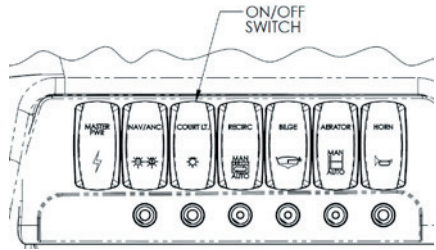

⚠ CAUTION

If the lights will be turned on for a prolonged period of time, start the engine while the battery contains adequate voltage to turn over the engine.

TILT STEERING WHEEL

A tilt steering wheel is standard on some models and can be raised or lowered by reaching under the wheel and releasing the tilt lock. Move the wheel up or down until it is comfortable and reset the tilt lock.

⚠ CAUTION

Never adjust the tilt steering wheel while the boat is moving. Doing so could result in loss of boat control.

NO-FEEDBACK STEERING SYSTEM

Some models are equipped with a No-Feedback (NFB) Steering System having a single cable. This system features a no-feedback mechanism that minimizes torque feedback at the helm. Overall boat control is improved because NFB steering reduces the natural tendency for the boat to steer to one side due to engine torque. BRP Marine US Inc. recommends that all boats rated for outboards larger than 115 hp be equipped with a NFB steering dual cable system.

NOTICE

Certain models may be equipped with hydraulic steering. Your engine owner's manual may also provide information on reducing engine torque via trim tab settings.

STEREO SYSTEM

Please consult your marine stereo owner's manual for operational information. To maintain your stereo in working order, always close the stereo box cover when the stereo is not in use. Your stereo will continue to play with the ignition off, so remember to turn it off at the unit to prevent discharge of the battery.

TOPS AND COVERS

Some models have convertible tops. The top is normally stowed in the stern area. It is conveniently covered with the vinyl boot. To use the top, remove from aft storage compartment and insert top bows into deck fitting and lock in place with locking pin. Snap the convertible top to the front and sides of the windshield. Snap the retaining strap to the gunwales and your top is ready for use. To remove the top, just reverse the procedure.

Mooring/travel covers are available for all Alumacraft boats. These covers are intended for covering your boat when it is stored outside or when trailering. Please contact your Alumacraft dealer for ordering information. All tops and covers must be allowed to dry before they are stowed. Spread out the cover or extend the top in a dry area until they are fully dry. This will prevent mildew from ruining your top or cover.

NOTICE

Tops and covers are not designed to withstand snow loads. Prevent snow from accumulating on the cover or top as damage may result.

WINDSHIELDS

Some models are equipped with walk through windshields. The center section of the windshield opens to allow access to the bow area. To open the center section, twist open the two latches and carefully open the window. The window opens to the port side and rests on rubber snubbers on the port console window. Remember to re-lock the two twist locks when the window is closed. The windshield will not open if the top is snapped in place.

Most side console models can be equipped with an optional removable windshield. These windshields can be taken off and reinstalled by manipulating the retaining pins or knobs. Contact your Alumacraft dealer for ordering information.

CAUTION

To avoid injury, glass door must be secured in a locked position when boat is underway. Use both turn locks to secure door.

SKI PYLON

⚠ WARNING
SKI PYLON IS FOR SKIING, WAKE BOARDING AND KNEE BOARDING ONLY.
DO NOT USE SKI PYLON FOR ANY OTHER PURPOSE (I.E. TUBING, PARASAILING, TOWING, ETC.).
PINCH POINT BETWEEN PYLON AND MOTOR. REMOVE PYLON PRIOR TO TRIMMING MOTOR UP. DO NOT SIT BESIDE OR BEHIND SKI PYLON WHILE IN USE. SEE OWNERS MANUAL FOR ADDITIONAL INFORMATION.
<small>Part: 22146010501 REV B</small>

⚠ WARNING
AVOID SERIOUS INJURY OR DEATH
• DISLODGED SKI PYLON MAY STRIKE SKIER OR OCCUPANTS OF BOAT. INSTALL SKI PYLON SECURELY BEFORE USE.
With pylon fully seated in under deck receiver and clevis pin installed the red line should be even with the top of the base. Failure to secure the pylon may result in injury or death.

<small>LABEL # 8123060</small>

Pylon Installation

- Follow ski pylon manufacturer's installation instructions provided with Ski Pylon kit.

⚠ WARNING
Failure to install ski pylon according to instructions could result in serious injury or death.

Pylon Use

- Make sure retainer pin or retainer bolt is installed in Ski Pylon Receiver at all times when in use, and Pylon is fully seated in Receiver.
- Check Ski Pylon Fasteners and Structure before every use to ensure there are no loose or damaged components.
- Never use a different Ski Pylon other than the one provided with kit from BRP Marine US Inc..

⚠ WARNING
<ul style="list-style-type: none">• Ski Pylon is for use with skiing, wake boarding and knee boarding. Do not use for any other purpose.• Do not sit beside or behind ski pylon while in use.• Pinch point between pylon and motor. Remove Pylon prior to trimming motor up.• Remove and stow pylon when trailering

Water Skiing, Wake Boarding and Knee Boarding

- **Always** wear an approved personal floatation device.
- **Always** turn off motor when in close proximity to skier or other swimmers.
- **Always** have a designated observer to watch the skier at all times, so the driver can dedicate full attention to safe operation of the watercraft.
- Only proficient swimmers should participate in water sports.
- Skiing and other water sports should only be done away from other boats, swimming areas, channels, and shallow areas.
- Retrieve a fallen skier immediately. They are defenseless in the water and may be difficult for other boats to see.

- Approach a person in the water from the down wind direction and from the driver's side, so the swimmer is always in sight of the driver.
- Respect others who are using the water. Leave plenty of space between you and them.
- Use caution when towing a skier, as rope may fly into cockpit if released.
- Be careful when skiing or doing other water sport activities, as any accident could result in severe injury or death.
- Only ski between sunrise to sunset.
- Refer to your local water authority for other laws that may pertain to your specific area.
- See the American Water Sports Industry Association (www.wsia.net) and the BoatUS Foundation for Boating Safety and Clean Water (www.boatus.org) for more information on skiing and wake boarding.

How to Tie Ski Rope to Pylon

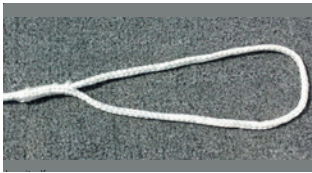

1. Lay rope flat

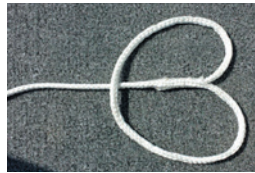

2. Flip loop back on itself

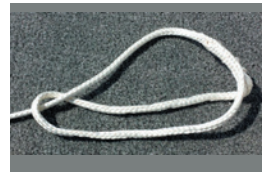

3. Pull rope through loop to make a new loop



4. Place new loop over pole



5. Pull rope tight

FUEL SYSTEM

Each time you fuel up, inspect the fuel lines, connections and fuel tanks for tightness, signs of leaks and deterioration. At least annually, conduct a more thorough inspection of fuel system components, especially those hidden from a routine inspection. Replace any deteriorated components.

Portable fuel tanks should also be inspected frequently for leakage along seams and at engine and tank connections. Portable tanks should be placed flat on the deck to prevent movement and should not be rested on or against fuel lines.

⚠ WARNING

Do not attempt to repair a leaking fuel tank or hose - replace it.

Keep your fuel tanks full during storage or periods of infrequent use to prevent condensation of water vapor and subsequent engine malfunction, if you are sure your fuel does not contain alcohol. But alcohol-containing fuel particularly absorbs humidity and it will separate from the fuel as the temperature drops during winter months, causing corrosion. Fuel tanks should be empty during storage if your fuel contains alcohol.

Leaking gasoline is a fire and explosion hazard. The natural ventilation which takes place when your boat is underway will remove the fumes, providing there is no leak of fuel to constantly replace them. But under certain wind conditions, fumes may tend to stay in the boat longer. It's a good idea to open up all hatches to allow compartments to air out before starting and keep them open until the boat is underway.

Do not paint aluminum fuel tanks with anti-foulants containing copper. Severe damage can result from galvanic action.

Outboard 2-cycle engines should use either TC-W II or TC-W3™ NMMA-certified oils. This applies to Personal Watercraft also. Check owner's manual for specific manufacturer recommendation.

FUEL

At the gas pump, you must take notice of the type of gasoline you are planning to pump. Do not use fuels containing more than 10 percent alcohol, or any alcohol derivative, such as ethanol. Usually, information about alcohol or ethanol content of the gasoline is posted on the pump. If not, always ask before you pump. High levels of alcohol in gasoline can damage marine fuel tanks, hoses, and components. In turn, these weakened structures can lead to leaks, which can result in fire and explosion. On a regular basis, inspect your boat's fuel system for leakage, weakening, hardening, swelling, or corrosion of components, including fuel tanks, fuel lines, fittings, fuel filters, and carburetors. If any components show signs of leakage, they must be replaced immediately. Consult the engine owner's manual for more information.

Note: If fuel cannot be pumped into the tank at a reasonable rate, contact your Alumacraft dealer.

Fuel blending varies by country and region. Your boat has been designed to operate using the recommended fuels; however, be aware of the following:

- Alcohol blended fuels attract and hold moisture which may lead to fuel phase separation and can result in engine performance problems or engine damage.
- Use of fuel containing alcohol above the percentage specified by government regulation can result in the following problems in outboard engines and fuel system components:
 - Vapor lock or fuel starvation
 - Starting and operating difficulties
 - Deterioration of rubber or plastic parts
 - Corrosion of metal parts
 - Damage to internal engine parts

Have your dealer inspect for fuel leaks or other fuel system abnormalities if you suspect the presence of alcohol in gasoline exceeds the current government regulation limits.

Refer to the manual for your outboard engine regarding recommended octane ratings specific to your engine. As a minimum, unleaded gasoline with an AKI (R+M)/2 octane rating of 87 should be used unless otherwise stated.

BIOBUTANOL (Bu16)

Fuel Biobutanol is a four-carbon alcohol produced from renewable, plant-derived energy sources in a fermentation process similar to beer and wine production. Biobutanol delivers more renewable energy content than ethanol while remaining compatible with current vehicles, boats, and infrastructure. Biobutanol does not phase separate in the presence of water like ethanol and is less corrosive to fuel system components such as fuel tanks, fuel fittings and fuel hoses. Biobutanol blended fuel (either isobutanol or n-butanol) may be used in all Alumacraft boats. Biobutanol blended fuel [Bu16 - up to 16.1% by volume] has been approved for use by the National Marine Manufacturers Association [NMMA]. More information can be found at <https://www.abetterbiofuel.com/>

USE IN NORTH AMERICA:

NOTICE - Do NOT use fuel from fuel pumps labeled E85. Never experiment with other fuels. The use of unleaded gasoline containing alcohol above the percentage specified by government regulations is not recommended. Use of fuel labeled E15 is prohibited by U.S. EPA Regulations

USE OUTSIDE NORTH AMERICA:

The use of unleaded gasoline containing alcohol above the percentage specified by local government regulations is not recommended.

USE IN THE EUROPEAN UNION:

Deployment of Alternative Fuels Infrastructure Directive 2014/94/EU. This directive provides harmonized labeling across Europe to effectively assist consumers in identifying the compatibility of fuels supplied at refueling points with an engine. All Alumacraft Boats are compatible with up to 10% ethanol fuel blends [E10]. The decal shown below should be present near the fuel filler cap of all recreational vessels.

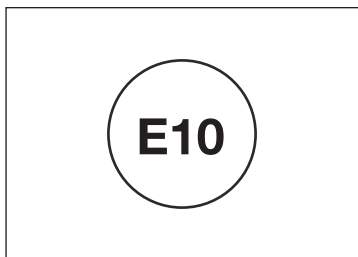

PORTABLE FUEL TANKS - PLACING AND SECURING

GUIDELINES

- A portable tank must **never** be placed in any enclosed space that is not designed for holding fuel containers. These restricted spaces are indicated on the boat by a warning sticker and do not have the proper ventilation required for storing fuel.
- A portable fuel tank should always be placed on a flat surface so that the tank sits level with the boat while in the boat's static floating position (calm water, boat is not underway).
- A portable fuel tank must be secured with a tank strap, or other similar means, to prevent the tank from sliding across the floor or decking and accidentally tipping, spilling, or contacting other equipment whose combination could create a hazardous situation.
- The proper placement of a portable fuel tank is determined by one of the following:
 - The designated portable fuel tank location, as described in the DESIGNATED LOCATION section of this document.
 - A location as indicated by approved collateral literature or other means (such as labels).
 - If no location is specified by the above means, the proper location is on the floor of the cockpit in a spot that will not potentially create a hazard, including a tripping hazard.

DESIGNATED LOCATION

ESCAPE 145 TL/CS, ESCAPE 165 TL/CS, SUMMIT 165

The proper location for a portable fuel tank is behind the removable aqueduct tray panel [aft cockpit bulkhead], under the aqueduct tray and lid, on the starboard side. The tank must be secured per the guidelines as stated in this document, whether the removable tray panel is installed or removed.

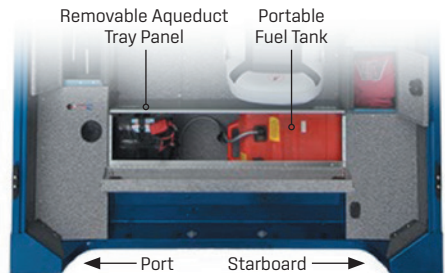

ALL OTHER BOATS

For a portable fuel tank on any other boat, including an extra portable tank on boats with designated locations, the tank must be located and secured per the guidelines as stated in this document.

SECTION 4: GETTING UNDERWAY

⚠ WARNING

Read and understand this operator's guide and the engine manual, and be sure that you understand all controls and operating instructions before attempting to operate the boat. Improper operation can be extremely hazardous.

LUBRICATION

All outboards require a quality oil to lubricate the inner workings of the engine. Some outboards require oil to be mixed with the fuel, while others have the oil directly added to the engine. Read your outboard motor owner's manual thoroughly and follow the instructions and specifications for your particular motor.

FUELING

⚠ WARNING

To avoid explosion when refueling, turn off the ignition switch and extinguish all smoking materials and flame producing items. Never smoke or light matches or lighters when fueling.

There are two types of fuel systems: portable carry-on tanks and built-in tanks. Portable gas tanks are supplied by the engine manufacturer and must be removed from the boat when fueling. Avoid overfilling the portable tank to prevent fuel spillage from the vent when the boat is underway.

Models equipped with built-in fuel tanks have a filler cap located in the splashwell or upper starboard side deck area. Each built-in tank also has a breather vent located in the splashwell or on the side of the boat. Keep these vent fittings clear at all times.

NOTICE

Please reference the supplemental guide on securing portable fuel tanks.

FUELING

When fueling your boat's main fuel tank, follow these steps:

1. Extinguish cigarettes, pipes, stoves, and all other flame producing items.
2. Make sure all power is off and do not operate any electrical switches.



3. Close all hatches. Gasoline is heavier than air and will flow to the lowest point.
4. Working in a well-ventilated area, remove the fuel tank cap. The contents may be under pressure; remove the cap carefully.
5. Insert the fuel supply nozzle.
6. After filling the tank to approximately 25 percent capacity, stop the pump, and inspect the engine and fuel tank area for signs of possible leaks or other issues.
7. If no issues are detected, continue pumping.
8. Stop filling the tank before fuel overflow occurs. Doing so leaves space in the tank for thermal expansion.
9. Tighten the fuel cap completely after refueling.
10. Check the engine oil level.

NOTICE

Each time you fill up, inspect fuel lines for leaks and hose deterioration or brittleness.

BOARDING

When boarding the boat, always step in. Do not jump. Avoid stepping on wet or slippery surfaces, and board one person at a time. Do not board the boat while carrying gear. Set the gear on the dock, board the boat and then pick-up the gear.

NOTICE

When re-boarding the boat from the water, please reference the Re-boarding Means section on pages 43-44.

WEIGHT DISTRIBUTION

Most boats require some adjustment in weight distribution in order to achieve the best port to starboard planing level. Passengers should distribute themselves to maintain even load distribution based on body weight, engine size, installed accessories, gear, etc. Remember to distribute weight evenly from starboard to port, and also from bow to stern. With some load conditions, it may also be necessary to change the propeller pitch to reduce the torque effect on boat performance.

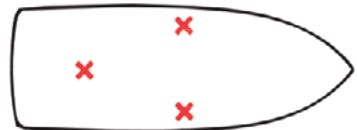

Proper Weight Distribution KC-1320.1



Improper (Bow Heavy) KC-1330.1



Improper (Starboard Heavy) KC-1340.1

NOTICE

Please reference the designated seating locations supplement for further information regarding seating positions while underway.

CAPACITY

Boats up to 26' in the National Marine Manufacturers Association (NMMA) program have a maximum rated load capacity, which is stated on the certification plate. The load capacity of boats under 20' are determined by the USCG. The person/load capacity is determined by various USCG formulas. Actual capacity is determined by the availability of proper seating on the boat. Acceptable seating determines the number of passengers, not the overall load capacity.

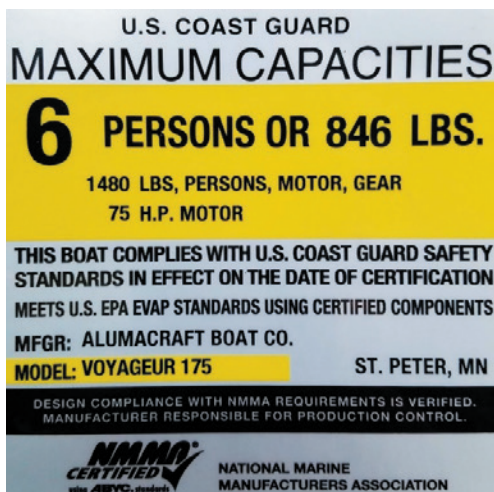

NOTICE

The capacity plate for outboard powered boats lists the maximum horsepower that the boat can safely use. It is unlawful to overpower a boat.

⚠ WARNING

Do not exceed the USCG certified maximum capacities under any circumstances. Overloading will reduce freeboard and increase the likelihood of swamping, especially in rough water. Overloading causes handling to become sluggish, making it difficult to react quickly.

Overpowering an outboard-powered craft is extremely dangerous. Overpowering will make the boat unstable and could cause loss of control.

PRE-OPERATION CHECKLIST

Before putting the boat in the water, always perform the following pre-operation checks:

- Check the weather report, wind and water conditions.
- Check that the required safety equipment is on board.
- Check that the fire extinguisher is fully charged.
- Check that bilge drain plug is installed properly.
- Check fuel filter for water.
- Check that no fuel, oil or water is leaking or has leaked into the bilge compartment.
- Check all hoses and connections for leakage and damage.
- Check the propeller for damage.
- Check the engine cooling water intake pick-up for blockage.
- Check that battery terminals are clean and tight.
- Check electrical circuits (lights, pumps, horn, etc.) for proper operation.
- Check that throttle/shift control is in neutral.
- Check that the steering system operates properly.
- Check that all required maintenance has been performed.

STARTING

Follow these steps when starting your motor:

1. Open the vent screw on the fuel tank [portable tanks].
2. Connect the fuel line to the fuel tank [portable tanks].
3. Squeeze the fuel primer bulb several times until firm.
4. Make sure the emergency engine stop switch is in place and connected to the operator.
5. Place the shift/throttle control lever in neutral.
6. Turn the ignition key clockwise to the start position. After the motor starts, release the key.
7. Push the control handle forward to go forward, pull back for reverse.

DRIVE TRIM ANGLE

Trim angle is the angular relationship between the lower drive unit and the transom of the boat. Boat trim while underway greatly affects boat performance and efficiency. For best results, the boat should be on plane and trimmed to reduce the wetted surface. With less boat in the water, both speed and fuel economy increase. Engines with manual trim must be adjusted for best overall operation for the load and conditions. Engines with power trim should be adjusted continuously for best results. If the engine is trimmed in too far (closer to the boat bottom), speed drops, fuel economy decreases, and the boat may not handle correctly. However, it does provide better acceleration from a stand still; and because it forces the bow down, visibility is improved. If the engine is trimmed out too far (away from the boat bottom), steering torque may increase, the boat may be difficult to get on a plane, and may bounce.

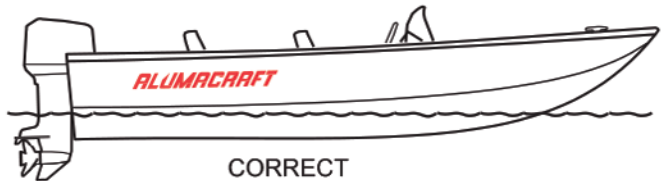

WARNING

Do not trim the engine out too far or the boat may begin to “porpoise” (bounce up and down). Porpoising reduces control and visibility.

To use power trim effectively, always start with the engine trimmed in. As the boat planes, increase the angle out. Experience is the best teacher for understanding proper trim.

STEERING

Avoid taking turns too sharply at high speeds. It is always wise to trim the motor down a little and give less gas when turning. When you experience heavy boat wakes or waves, turn directly into the wake or wave for safest operation.

OPERATION CHECKLIST

While operating your boat, do the following:

- Check gauges frequently for signs of abnormal behavior.
- Check that controls operate smoothly.
- Check for excessive vibration.

STOPPING

1. Slowly bring the shift/throttle lever to the idle position. If the boat has been driven for a long period of time at high speed, allow the engine a 2-3 minute cool-down period at low idle.
2. Turn the ignition key to the OFF position.
3. If any problems were encountered during the outing, have the boat inspected by your dealer and request any necessary repairs before the next outing.

⚠ WARNING

Do not use the emergency engine stop switch for normal shut down. Doing so may impair your ability to re-start the engine quickly or may create a hazardous swamping condition by creating a sudden rush of backwash over the transom. Normal shut down is a function of the ignition key.

ANCHORING

There are many types of anchors available on the market. The choice of one anchor over another depends on many factors. An anchor will usually hold best in a mixture of mud and clay or in hard sand. A lightweight Danforth anchor is recommended for general boating. For more information on anchors consult your dealer.



DANFORTH ANCHOR

KC-1571

⚠ WARNING

Always anchor from the bow; NEVER anchor from the stern. A small amount of current will make the boat unsteady... a strong current can pull a boat, anchored by the stern, under water and keep it there.

When anchoring, it is helpful to keep a few guidelines in mind:

- Make sure the line is tied to the anchor and tie the other end of the line to the forward cleat or bow eye.
- Head the boat into the wind or current over the spot where you want to lower the anchor.
- Stop the boat before lowering the anchor.
- When the anchor hits bottom, slowly back up the boat, keeping tension on the line. Let out an anchor line that is 8 to 10 times the depth of the water. For example, if you are in 10 ft. [3.0 m] of water, let out 80 to 100 ft. [24 to 30 m] of line.
- Secure anchor line to the bow cleat. Pull on line to make sure anchor is holding.
- Occasionally check your position against the shoreline. If the anchor is dragging and you are drifting, reset the anchor.

DOCKING

Practice docking before attempting it for the first time. Use a float, like a plastic milk jug with a line and small weight, as your docking target.

WARNING

Never use your hand, arm or other part of your body to attempt to keep the boat from hitting the dock. The boat could push against the dock, causing injury.

Follow these guidelines when docking:

- Approach docks with the port side of the boat if possible.
- Come to a stop a short distance from the dock, then proceed slowly.
- Have fenders, mooring lines and crew ready.
- Observe how the wind and current are moving your boat. Approach the dock with the boat pointed into the wind, if possible. If the wind or current is pushing you away from the dock, use a sharper angle of approach. If you must approach the dock downwind or down current, use a slow speed and shallow angle. Be ready to reverse to stop and maintain position.
- If there is no wind or current, approach the dock at a 10 to 20 degree angle.
- If possible, throw a line to a person on the dock and have that person secure a bow line.
- With the bow secure, swing the stern in with the engine, or pull it in with a boat hook.

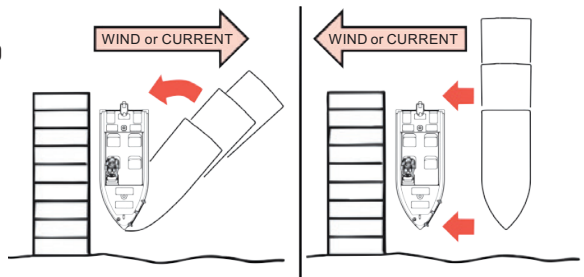

KC-1123.1

Before tying-up the boat, be sure to use enough fenders to protect the boat from damage. If possible, tie-up with the bow towards the waves with a good quality doublebraided nylon line. Tie-up only to the tie-down eyes; never use the handrails or windshield frames. Leave a little slack in the lines to allow for some wave movement or tidal action if applicable.

Follow these guidelines when departing:

- Very slowly shift into forward at idle speed.
- When the stern moves away from the dock, turn the engine away from the dock.
- Cast off bow line and back away.
- If the wind or current is pushing away from the dock, cast off all lines and allow to drift until you are clear.

POST-OPERATION CHECKLIST

After you have removed your boat from the water, do the following:

- Fill fuel tank to prevent moisture due to condensation.
- Check for fuel, oil and water leakage.
- Check the propeller for damage.
- Remove the drain plug and allow any water to completely drain.
- If applicable, allow the boat to completely dry before replacing any covers.

SECTION 5: TRAILERING

This section provides information about trailer selection and trailering in general. It describes how to choose the right trailer for your Alumacraft boat and discusses the hitch and safety chains, backing your trailer, preparing to launch, launching, and loading your trailer. Also included is a trailering checklist.

CHOOSING THE CORRECT TRAILER

Improper trailer selection is the most common cause for boat hull damage. If your boat was purchased without a trailer, make sure you select one that matches your boat for weight and hull design. Consider the amount of towing you'll be doing, the roads you will be traveling, the additional cargo that will be transported in your boat, and the type of landings you will be using.

Suspension matched to load capacity and longer leaf-springs will provide your boat with a smoother ride during transport. Also consider that your boat may spend most of the time on the trailer, so it should be of the correct capacity. For example, if your boat is listed as having a shipping weight of 1000 lb. [454 kg] and you decide to buy a 1200 lb. [544 kg] capacity trailer, it will be under capacity with the addition of an outboard motor, gas and any other gear. Likewise, a trailer over capacity for your boat will yield a rough ride, stressing the hull and loosening hardware and rivets. BRP Marine US Inc. recommends you choose a trailer that is rated **at 30% more than the total weight of the boat, engine and equipment.**

If you will be towing your boat long distances on rough roads, avoid small diameter tires, and keep in mind that the lower your boat rides on the trailer, the easier it will be to tow, load and launch. When choosing a trailer, note that the roller bunk style trailer will provide excellent loading features but not maximum hull support. The full bunk support design on bunk trailers provides the best hull support. If you have a deep vee hull boat, you may consider a self centering, drive-on/drive off trailer. Your Alumacraft dealer can help you make your choice.

NOTICE

If the trailer you are considering does not provide the proper support for the transom, keel, winch and bow, and does not give the correct boat stabilization in accordance with the following guidelines, the boat hull warranty will be void.

NOTICE

The trailer axles are adjustable and may need to be changed based on the gear and accessories installed by the customer. Verify that the axles are adjusted per GVWR tongue weight recommendations.

TRANSOM SUPPORT

The transom support must carry more than half of the total weight of the boat, engine and gear.

BUNK TRAILERS

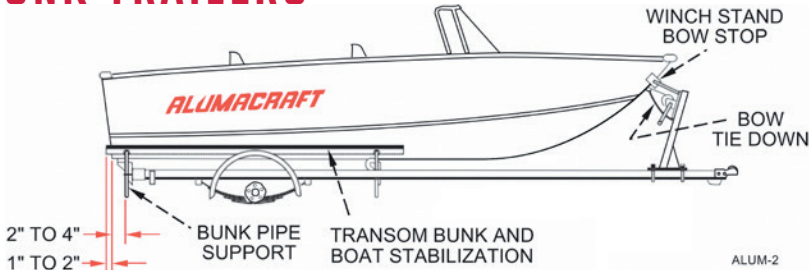

Position the carpeted bunks as far apart as practical. Pull the boat onto the trailer until the bunk pipe is within approximately 2 to 4 in. [5.1 to 10.2 cm] of the transom, and the bunks extend 1 to 2 in. [2.5 to 5.1 cm] beyond the transom. If the boat is loaded further back than this, the excess weight could cause the bunk supports to slip violently, causing damage to the hull. This will void the warranty.

When locating and adjusting trailer bunk supports to boats with longitudinal type frames, care must be taken to place the bunks directly underneath the outside longitudinals. The outside longitudinal can be identified by locating the second row of rivets from the center keel on the hull bottom. On Classic and Escape models, this is approximately 17 in [43 cm] while Competitor and Trophy models, this is approximately 24 in [61 cm].

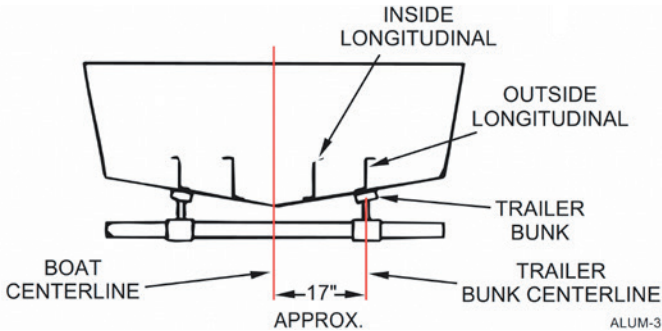

Models have been condensed in MY24 and beyond.

Alumacraft boats with longitudinal framing include the Classics, Escapes, Competitors and Trophy.

These recommendations do not apply to any of the models that have rib type construction. Contact the Alumacraft service department if you have further questions.

ROLLER BUNK TRAILERS

Space the rear roller clusters in or out to miss the strakes on the boat hull. Pull the boat onto the trailer until the rear edge of the transom is flush with the rear rollers. Make sure the rollers spin and conform to the hull when you pull the boat over the rear clusters. The rollers must have full contact with the hull or damage may occur which is not covered under your warranty. Also, make sure the clearance between the fenders and the hull is adequate. If the hull is too close, adjust the rear roller cluster up to provide about 1.5 in. [3.8 cm] clearance between the fender and hull.

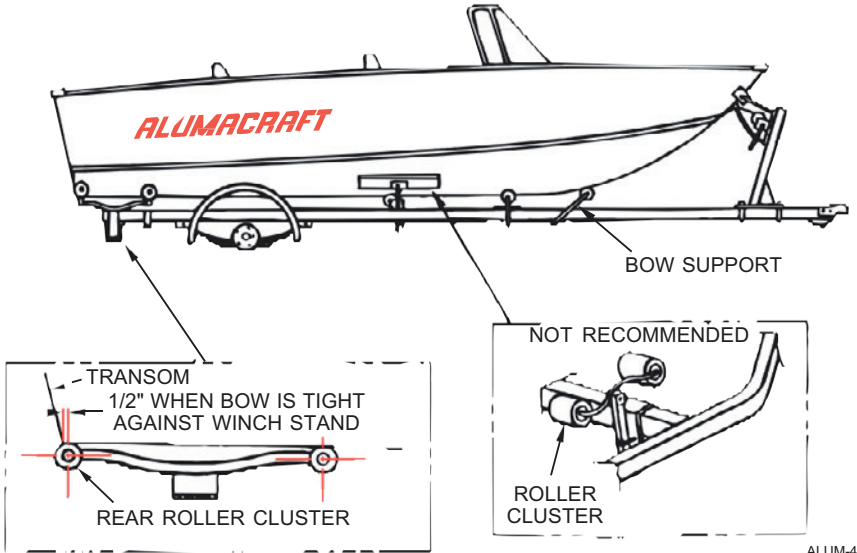

NOTICE

BRP Marine US Inc. does not recommend roller clusters for stability. In most cases, adjustments are not properly made and are difficult to maintain. Over time, the boat settles into the rollers and correct lowering adjustments are not made to the clusters. Improper trailer adjustments will void the warranty.

KEEL SUPPORT

For all trailer types, confirm the boat keel is resting on the keel roller and that the keel is not in contact with any other rollers at this time. Adjust the keel roller to provide a minimum of 1 in. [2.5 cm] clearance between the trailer frame and keel of the boat. Bring up more rollers to contact the keel. These additional rollers are used for loading and unloading your boat, and should carry very little weight. Whenever possible, rollers should be positioned over the boat's cross ribs.

NOTICE

When loading your boat onto the trailer, be sure the bunks and rollers are partially submerged in the water. Failure to do this can result in hull or trailer damage. Limit aggressive power loading to further protect the hull and trailer.

WINCH STAND AND BOW SUPPORT

Adjust the winch stand bow stop directly above the bow eye and tighten the winch line. As the winch line is tightened, you should have a slight downward pull on the boat. With the boat pushed back approximately 4 in. [10.2 cm] from the winch stand bow support, position the bow support bracket between the keel and the tongue. As the boat is pulled against the winch stand bow stop, the bow support bracket will carry a portion of the forward weight of the boat and prevent the boat from being pulled down by the winch.

BOAT STABILIZATION

For all roller bunk trailers, adjust the carpeted forward bunk stabilizers up to the hull. These forward bunks are used only for stability and need only be tight enough to prevent the boat from leaning.

SELF CENTERING KEEL ROLLER TRAILERS

BRP Marine US Inc. recognizes that there are many different styles of trailers on the market and that some customers prefer "all roller" style trailers for ease of launching and loading. Trailers that have the self centering keel rollers in the forward part of the trailer are perfectly acceptable when used in conjunction with aft roller systems. BRP Marine US Inc. recommends the use of polyethylene style rollers for the keel roller and the boat support roller for durability purposes.

SECURING THE BOAT TO THE TRAILER

BRP Marine US Inc. requires that your boat be securely fastened to the trailer when towing to prevent the boat from bouncing up and down and causing serious damage to the hull. BRP Marine US Inc. recommends two stern hold down straps fastened to the trailer and to the stainless eyes on the transom of the boat. These straps should be of the type that can easily be tightened down for towing and loosened for removal. BRP Marine US Inc. also requires your boat be fastened to the trailer by a line from the bow eye to the winch line PLUS a bow tie-down to the winch stand or trailer tongue. The bow tie-down can be a short strap that can be tightened, or a short piece of chain with a heavy hook.

TRAILERING

Trailer laws on things such as lighting, registration, trailer brakes, gross vehicle weight, etc., vary widely from state to state. Contact your state Department of Motor Vehicles [and that of other states through which you may be traveling] for laws with which you must be in compliance.

⚠️ WARNING

The towing vehicle must have the capability of pulling the load. Pulling a load that exceeds the vehicle's towing capacity may cause a loss of control.

NOTICE

Check the certification label on the left forward side of your trailer. The label is required to show the Gross Vehicle Weight Rating (GVWR), which is the load carrying capacity plus the weight of the trailer itself. Be sure that the total weight of your boat, engine, gear, and trailer do not exceed the GVWR.

Below is a checklist to follow when trailering your boat:

- Consult your state laws as to brake and axle load requirements. Check brakes for proper operation and fluid level prior to departure on each trip.
- Check springs and undercarriage for loose parts.
- Check tires for proper inflation. Under-inflated tires heat up rapidly and tire damage or failure is likely to occur.
- Check wheel bearings and lug nuts before each trip.

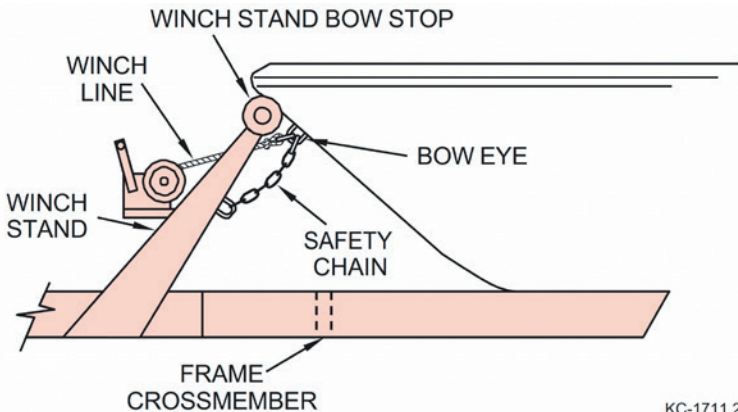

- Your boat should be fastened to the trailer by a line from the bow eye to the winch line PLUS a safety chain from the winch stand to the bow eye. The stern of your boat should be tied down to the trailer from the stern eyes.
- Check that the taillights and turning signals work prior to towing.
- Too much or too little tongue weight will cause difficult steering and will make tow vehicle sway. A rough rule of thumb is 5% to 10% of boat and trailer weight on the tongue.
- Convertible tops are not designed to stay on boats at highway speeds. Before towing, take down the convertible top, side curtains, and back cover.
- Carry a spare tire for both your trailer and your towing vehicle along with sufficient tools to change them.
- Consult the engine operator's manual for engine related trailering precautions.
- On extended trips, carry spare wheel bearings, seals, and races.
- While traveling, check the wheel hubs every time you stop to rest or refuel. If the hub feels abnormally hot, the bearing should be inspected before continuing your trip.
- When rounding turns on highways or streets, do not cut corners. Also, go slow over railroad tracks.
- Never trailer your boat with the motor in the fully tilted (up) position. This will cause severe stress to the transom. If there is insufficient ground clearance, use a weight transfer bar that holds the motor up and distributes the motor weight to the trailer. Outboard motors should also be tied in place so they will not tilt or turn due to road shock. Continuous road shock may fatigue the boat steering system.
- Before backing your trailer into water, disconnect the light plug from the towing vehicle to reduce the likelihood of blowing out lights when they become submerged.

WARNING

Before trailering, make sure seats, accessories, loose items and cargo are stored or properly secured, or remove it to prevent from falling on the road and creating a hazard for following vehicles.

LAUNCHING

Before launching your boat, stay to one side and watch a couple of launchings to notice any problems on the ramp and the effects of the wind and current on launching. It is a common courtesy to prepare the boat for launching away from the ramp especially during busy periods. Perform the pre-launch sequence as follows:

1. Remove the boat cover, if equipped.
2. Check that bilge drain plug is in place.
3. Remove aft trailering tie-downs from the boat.
4. Attach the bow and stern docking lines and fenders if necessary.
5. Disconnect the trailer lights from the towing vehicle.

SECTION 6: MAINTENANCE AND STORAGE

Your new Alumacraft will provide years of dependable service if properly maintained and stored. This section describes how to keep your boat in tiptop condition. It includes information about maintaining the boat's appearance and components and performing minor repairs.

CARE OF YOUR BOAT'S APPEARANCE

ALUMINUM HULL

The hull of your Alumacraft boat is constructed of a high grade marine aluminum alloy that greatly increases the longevity of your boat's appearance. Your boat hull is also protected by a corrosion resistant urethane finish for years of trouble free good looks. To maintain this appearance, always rinse your boat with fresh water after removing it from salt, polluted, or brackish water and when the boat has been transported over salty roads. If your boat is often exposed to such conditions, it is recommended you have your dealer install a transom mounted zinc anode to prevent galvanic corrosion [electrolysis] to those metal parts coming in contact with the water.

Occasionally wash the hull with a mild detergent and warm water. Do not use abrasive cleansers or solvents as these could damage the finish. Under extreme conditions, special cleaners may be used to remove marine growth, such as scum and algae, from the hull; see your dealer. An occasional application of a quality automotive wax will also help to preserve your boat's original finish.

OUTBOARD MOTOR

Like any metal part on your boat, your outboard motor is susceptible to electrolysis. One or more sacrificial zinc anode is usually attached to the engine's lower unit to prevent corrosion of the motor. As the boat ages, these anodes deteriorate and may eventually require replacement. See your engine owner's manual for the exact location of these anodes. Inspect the anodes on a regular basis and replace them when the time comes. Your Alumacraft dealer can also provide this service.

VINYL UPHOLSTERY

Regular washing with dishwashing soap and warm water or non-solvent type automotive vinyl cleaner is sufficient to keep the cushions, canopy top, and vinyl coverings in good condition. Periodically lubricate the canopy top snaps with petroleum jelly to prevent corrosion. For tough stains on vinyl, such as adhesive and rust, use citrus cleaner and rinse with dishwashing soap and warm water. For ink, apply denatured alcohol to the stain and wipe off.

Thoroughly drying the upholstery and allowing inner foam materials to dry before covering the boat is key in preventing mildew growth. Should your upholstery become mildewed, remove the stains with the following mixture and rinse with warm water:

- 1 teaspoon ammonia
- 1/4 cup hydrogen peroxide
- 3/4 cup distilled water

A 4:1 mixture of water and ammonia will kill bacteria causing mildew. If desired, a mildew repellent may allow be applied.

Avoid using products such as Armor All, 409 or waxes which may contain solvents that will damage the protective coating on vinyl. Never use industrial cleaners, powdered abrasives or steel wool which can scratch and cause discoloration. Note that some items, such as suntan lotion, shoe polish and wet leaves may stain permanently.

Although not always practical, minimizing your boat's contact with damaging UV rays and storing removable seats and canopies indoors during the off season will increase the longevity of your vinyl upholstery.

CARPET

Occasional vacuuming and washing with mild detergent and warm water or household carpet cleaners will keep the carpet clean. Thoroughly hose the detergent out of the carpet and into the bilge. This is usually the best time to clean the bilge. Let the carpet dry in the sun to prevent any mildew or odor caused by moisture.

WINDSHIELD

A clean windshield is important. If your boat is equipped with a glass walk-through style windshield, applying a quality glass cleaner with a soft cloth will remove most accumulations of dirt. Smoked plexi-glass or plastic windshields, however, require special cleaning precautions to prevent scratches. Use a mild soap solution and damp cloth only. Harsh detergents, solvents, chemicals or dry cloths will scratch plastic windshields. If your windshield becomes cracked or excessively scratched, replacements are available through your Alumacraft dealer.

MAINTENANCE AND STORAGE

For most regular maintenance operations, you will probably want your Alumacraft dealer to do the work for you. However, there are many minor maintenance items you can take care of yourself.

BATTERIES

WARNING

Batteries contain sulfuric acid which can cause severe burns. Wear protective clothing when handling batteries to avoid acid contact with skin, eyes, etc.

WARNING

Batteries produce explosive hydrogen gas. Never attempt starting your engine with jumper cables under any circumstances. Keep all sparks, flames and smoking materials away from batteries. Risk of spark at the battery post igniting gasoline or hydrogen fumes is too great. Always open the battery hatches or remove the batteries from the boat to provide adequate ventilation. An explosion can cause blindness or other serious injuries.

If equipped with electric start, your boat has a cranking battery that is charged automatically by the outboard motor alternator when the engine is operating. Therefore, the cranking battery does not require charging with an external charger. The trolling motor batteries, however, are independent of the cranking battery and must be recharged on shore with a battery charger. It is a good idea to recharge your deep cycle batteries slowly and often with a deep cycle battery charger. Allowing the batteries to sit after use without charging will shorten the life of the batteries as will “zapping” them with a heavy, quick charge instead of charging them slowly over a longer period of time.

Some models have a trolling motor plug receptacle on a panel at the bow that makes it possible to charge the trolling motor batteries directly through this receptacle. To use this feature, you must wire your charger with the same type of plug found on your trolling motor power cord. These plugs are available through your Alumacraft

NOTICE

BRP Marine US Inc. provides battery trays and restraints that are sized to the most common engine and trolling motor manufacturer's battery recommendations. Always use the appropriate type and size of battery according to the engine and trolling motor manufacturer's recommendations. Always use a properly sized battery tray and restraint for each battery.

dealer. For most models, this system allows two deep cycle batteries to be wired in series for 24V, or in parallel for 12V using two batteries.

The batteries must not be connected by any jumpers or wires other than the red #8 lead marked BATT 1 to battery 1, the orange #8 lead marked BATT 2 to battery two, and a black ground lead to each of the negative terminals. Attach these wires to the batteries as indicated. This will yield either 12V or 24V from the plug receptacle depending on whether the batteries are wired in parallel or series. For charging, plug the male connector from the charger into the plug receptacle and both batteries will charge at once. Note that when charging in this manner, the batteries and wiring are not fuse protected.

In addition to keeping your batteries charged, frequently check your battery terminals for corrosion. If required, clean the terminals with a wire brush and a baking soda/ water solution. Also check the fluid levels in the cells. Usually, a level approximately 0.25 to 0.75 in. [6.4 to 19.1 mm] above the plates is sufficient. If needed, fill the batteries with distilled water. If your batteries are sealed, the checking and filling process is not necessary.

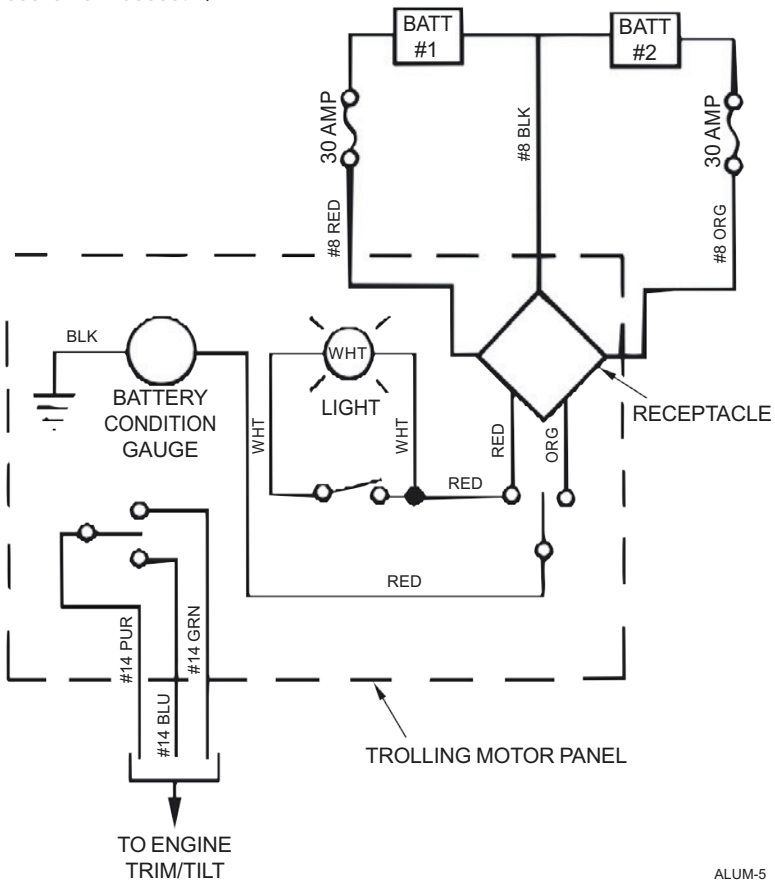

ALUM-5

FUSES

⚠ WARNING

Never exceed the recommended fuse sizes or bypass the fuse safeguard. Always install the proper [type and rating] fuses whenever replacing or changing fuses. Continuous fuse failures indicate a severe problem that requires immediate attention. Failure to install correct fuse may result in damage to the electrical system or severe personal injury.

All electrical circuits are protected from overload by the use of fuses. Often, when an electric item such as a horn or light does not work, it is as simple as replacing a fuse. In the event of an overload, first locate the fuse panel. On most boats with consoles, the fuse panel [Fig. 1] will be located at the side of the console. On tiller controlled boats, the panel may be located in the aft section of the boat. Some electrical devices, such as the stereo, have an additional fuse located inside of an in-line fuse holder near the device itself. Locate the blown fuse and replace it with one of the same style and amperage rating as the blown fuse. If a fuse continues to blow, have your boat inspected by your Alumacraft dealer.

Some boats may be equipped with circuit breakers [Fig. 2] installed on **the main boat harness and on the trolling motor harness(es)**. Reset Manual circuit breakers by pressing the reset button on the circuit breaker. Auto-reset circuit breakers will reset automatically after overload.

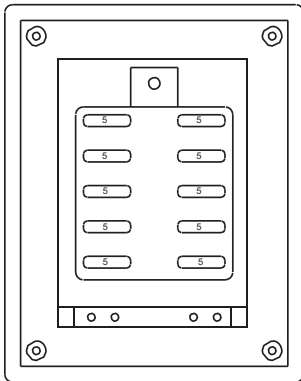

AUTOMOTIVE STYLE
FUSE PANEL

ALUM-6

Fig. 1

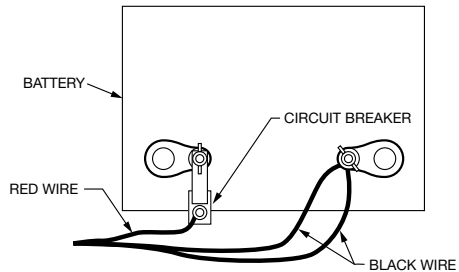

Fig. 2

NOTICE

Most electrical devices do not use a fuse larger than 5 amps. If you find a fuse larger than 5 amps, other than accessory, consult your Alumacraft dealer to determine the correct fuse rating.

LED LIGHTS

Replacement LED lights can be found at your Alumacraft dealer.

SCREWS AND BOLTS

The vibrations and pounding of the marine environment may loosen screws and bolts. Check all visible screws and bolts to be sure that they are tight. If not, tighten them securely. Check the seat pedestal screws, dashboard screws and bolts and all hinge screws. Open all hatches and look for screws inside hatches and lockers. Open the transom curtain and check all the screws that you can find. Don't over-tighten the screws. If you find a screw that will only spin, and won't tighten, consult your Alumacraft dealer.

BILGE PUMP

The bilge pump should be checked and cleaned periodically to ensure proper operation. If the pump runs but fails to pump water, turn it off, remove the filter screen and inspect for clogging. Re-activate the pump to make sure the pump's impeller is operating. If so, turn off the pump, restore the screen, and restart the pump.

ATTACHING ACCESSORIES

See unique LinQ accessory options at alumacraft-gear.com. When selecting accessories you must choose accessories and fasteners made from plastic, aluminum or stainless steel. Do not use copper, brass, bronze, iron or ordinary steel items. If you need to drill into the boat's hull to attach an item, and do not have the necessary expertise, contact your Alumacraft dealer for help. If you will be attaching fittings or transducers below the water line, you must be sure to seal the screw or bolt with marine sealer, designed for below waterline use. It's always best to use a stainless steel bolt and nut with washers when fastening things to a boat, however, it not possible to use this arrangement. In these cases, use stainless steel self tapping screws and sealer.



**LEARN MORE
ABOUT LINQ**

KEEPING THE BOAT DOCKED IN THE WATER

If your boat will be docked in the water, it should be covered with a mooring cover to protect the boat from rain damage, or the damaging effects of sunlight. If possible, raise the motor out of the water. You should arrange to remove the boat from the water periodically to remove algae or other marine growth.

NOTICE

Keeping the bottom of the hull clean is especially important. A clean boat performs better and is more energy efficient.

If the boat will be docked in salt or brackish water, it must be removed often and inspected for pitting or corrosion. You must rinse the hull with fresh water after use in salt or brackish water.

If you decide to use an antifouling protection for the hull, do not use any metal base paints or compounds. If the paint or compound contains copper, mercury, arsenic or lead, it must not be applied to an aluminum hull. If you want extra protection for the hull in salt or brackish water use an anti fouling paint that contains an organotin base, such as tributyltin oxide.

STORAGE

Without proper preparation, storage for long periods of time will take its toll on your boat's appearance and performance. To ensure your boat is properly stored in the off season, complete the following recommendations:

- Clean the boat's exterior and interior, and make sure you let the boat and all hatches dry completely.
- Wax the exterior of the boat.
- Remove all batteries and put them in a warm place. Charge the batteries once every month while they are in storage.

NOTICE

Do not store your battery on concrete because concrete can leach into your battery and damage it.

- Remove all gear from the boat.
- Remove the electric trolling motor and store it in a warm place.
- Verify the livewell and baitwell have no water in them.
- Pull the plug and drain the bilge. Use a sponge to completely dry the bilge area.
- Run the aerator and bilge pump momentarily to ensure all lines are clear of water.
- Raise the bow of the boat much higher than the stern to ensure complete water drainage from all hose lines.
- Try to store your boat in a garage or indoor storage area. If this is not possible, make sure the boat is covered. You can use a commercial heat shrink boat wrap only if it is vented.
- Smaller boats are sometimes stripped and stored outside. If you do this, you must either store the boat upside down or keep the stern angled down to drain excess water.
- Never store the boat directly on concrete. Always use wood or cardboard between the hull and concrete.

REACTIVATING THE BOAT AFTER STORAGE

After removing your boat from storage, complete the following operations prior to hitting the water:

- Check the expiration dates on safety gear such as flares and fire extinguishers.
- Check all lights on the boat and trailer.
- Make sure your boat insurance policy is up-to-date.
- Check the gear lube in the engine lower unit and make sure no water is present. If it is, contact or dealer before starting the motor.
- Grease all zerk fittings in accordance with the engine owner's manual.
- Check the fuel system including tank, fittings, fuel lines and hoses for leaks.
- Connect the batteries and check all electrical connections. Inspect the steering system linkage and make sure the steering wheel turns freely.
- Inspect all livewell, baitwell, bilge pump and thru hull fittings and hoses.
- Backflush all hoses to remove any accumulated debris.
- If you notice any problems, see Section 9 - Troubleshooting or contact your Alumacraft dealer before using your boat.

SECTION 7: FEATURES FOR THE ANGLER

TROLLING MOTOR

If you purchased your boat with a trolling motor, it is designed to provide quiet propulsion and precise maneuvering while you are fishing. When operating, the motor draws power from one or more of its deep cycle batteries so make sure you charge them for optimum trolling motor performance. Charging technique is described in **Section 6 - Maintenance and Storage**.

Consult your trolling motor operator's manual for installation, maintenance and operational information.

TROLLING MOTOR BATTERY SYSTEM CONFIGURATION

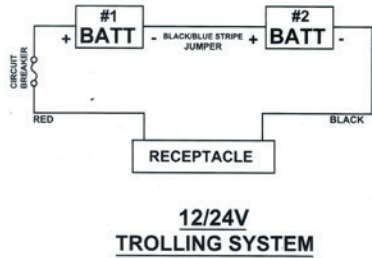
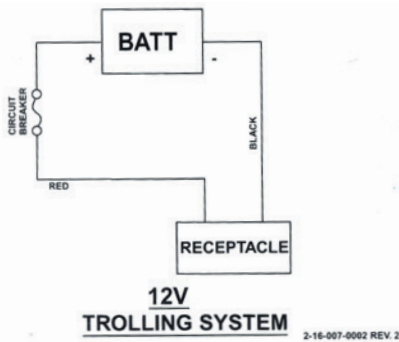

2-16-007-0005 REV. 1

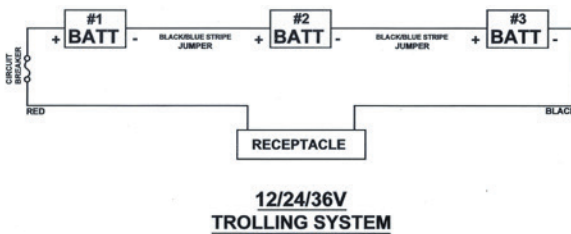

22160009211 REV. A

TRIM AND TILT SWITCH

Some models will have The trim and tilt switch that makes it convenient for a fisherman seated at the bow to raise and lower the outboard motor. This is useful when you are fishing in shallow water, or in areas with rocks or stumps. Push the switch up to raise the motor and down to lower it.

LIVEWELLS

NOTICE

Never allow soap or detergents inside the livewell or baitwell. Residue from cleaners may be harmful to fish and bait.

NOTICE

To avoid freeze damage to the livewell or baitwell system, be sure they are completely empty in freezing weather. Water that freezes will expand and could burst the hoses.

NOTICE

Fish or bait may stay alive all day in cold weather without aeration. However, they must be aerated frequently on warm days to keep them alive and fresh.

Your Alumacraft boat may be equipped with one of the following types of livewells:

AERATED LIVEWELLS

All aerated livewells have at least one drain hole and an aerator. The conventional style has an overflow drain and a drain hole with a rubber plug located at the bottom of the livewell. Standpipe livewells function in the same manner, but have a rigid tube that fits into a drain hole at the bottom of the livewell for overflow as well as drainage. When the water level reaches the top of the pipe, the overflow exists out the tube through the drain hole.

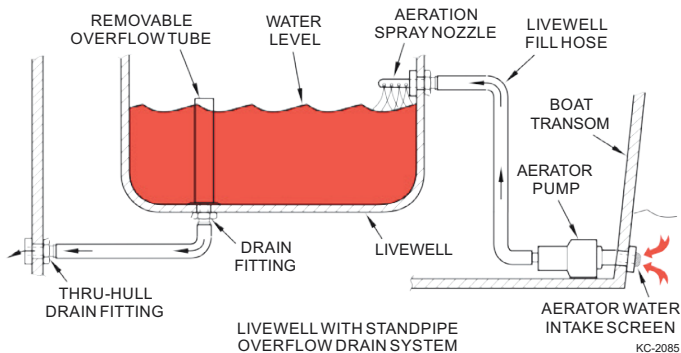

To use the aerated livewell, first install the drain plug or standpipe. Activate the switch labeled AERATOR on the dash or bow panel to pump water through the spray head and fill livewell. Turn off the pump when the livewell is sufficiently full. Note that the livewell will not fill unless you are stopped or going slowly. This is normal operation.

Never allow the pump to run dry, as this will damage the pump. If you have fish in the livewell, periodically turn the aerator on for 3 to 5 minutes to add fresh water. To drain the livewell, remove the rubber plug or standpipe.

RECIRCULATING AERATED LIVEWELLS

Recirculating aerated livewells come in two different types. Some models have special valves located near a single pump that allow remote control of the fill and drain functions. Other types are equipped with two pumps and require operator's guide manipulation of the drain plug for filling and emptying the livewell.

Systems equipped with two pumps use one pump to fill the livewell and a separate pump to remove water from the bottom of the livewell and add oxygen through an aerated head. This system requires the insertion or removal of the livewell drain plug for the filling and draining functions. The recirculating pump is operated by a switch mounted on the dash panel. Each of these systems has an overflow drain.

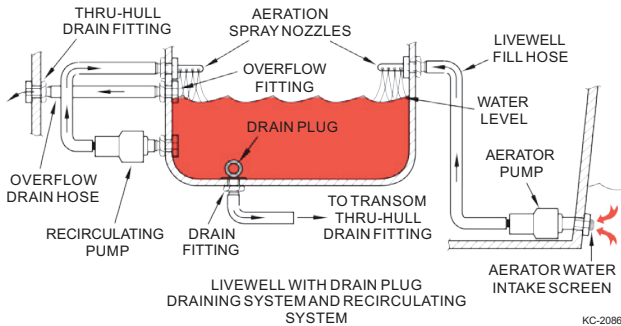

Operation of systems with the remote control function is fully automatic. Put the cable control in the FILL position and activate the livewell pump to fill the system. Leave the cable control in this position until you wish to drain the system. Whenever the pump is running, a quantity of water is drawn from the drain and mixed with fresh water to add oxygen to the livewell water. It also prevents water loss and allows the pump to recirculate the livewell water when running at high speed or when the boat is out of the water. To drain the livewell, turn off the pump and move the control to the EMPTY position.

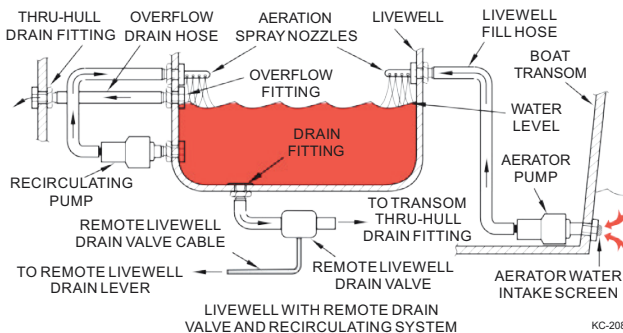

DUAL RECIRCULATING AERATED LIVEWELLS

Some of the larger boats are equipped with two recirculating aerated livewells. To use only the aft livewell, turn off the aerator head valve in the forward livewell and all pump output will be diverted to the aft livewell. To use both livewells at the same time, you must adjust the valve in the aft livewell to split the flow to both aerator heads. To use only the forward livewell, close the valve to the aft livewell, diverting all water to the front livewell. You must use the drain plug in the bottom of the forward livewell. Water from this livewell does not get recirculated through the pump, but drains directly out of the boat.

AERATOR TIMERS

Aerator timers are built into the aerator systems on some models. The AERATOR switch on the dash panel has three positions: MAN [manual], OFF [in the center], and AUTO [automatic]. The manual position turns the pump on or off, while the automatic position turns control over to the timer. Fixed interval timers have no adjusting knob for "off" time. It is preset at approximately 3 minutes with the "on" time about 1 minute.

NOTICE

When using dual recirculating aerated livewells, do not use recirculating mode for both livewells when the boat is out of the water or running at high speed. Doing this may cause all water to be pumped from the aft livewell to the forward livewell.

BAITWELLS

Your Alumacraft may be equipped with one or more individual baitwells or have removable baitwells located in the livewells. Baitwells are actually miniature livewells used to keep your minnows, leeches and other aquatic bait fresh and lively. The baitwell is filled by running the livewell aerator pump. To quickly fill the baitwells, adjust the livewell valve for less output. The aerator valve in the baitwell must also be adjusted to regulate the desired flow and prevent drainage through the overflow drain or standpipe. Remember to aerate the baitwell regularly. The livewell aerator timer will also control the aeration of the baitwells. Close the baitwell valve when not in use.

Make sure all bait is removed from the baitwells before draining, and then remove the drain plug or standpipe. Replace the plug or standpipe before refilling.

Your baitwell system aerates the water by continuously pumping freshwater into the well. The spray head breaks the water into many small streams that splash into the water, thereby introducing oxygen into the baitwell. To fill the baitwell, open the valve and activate the baitwell pump. The water level will be maintained to the height of the overflow. To empty the baitwell, turn off the baitwell pump and remove the drain plug or standpipe.

SECTION 8: ROTAX OUTBOARD EQUIPPED MODELS

MAX DECK

The pivoting cover of the MAX Deck swim platform can be manually lifted to a vertical position to access integrated Rotax S engine or the stern lifting eyes. To achieve the vertical position, the two bungee cords must be detached from the pivoting cover.

⚠ WARNING

Always confirm that the bungee cords are re-attached and secured on the pivoting cover after service or maintenance operations have been performed. Severe injury or death could occur from the unattached pivoting cover striking an occupant in the event of an underwater impact with the outboard engine.

⚠ WARNING

Avoid severe injury or death from the pivoting cover suddenly dropping down. Always secure the pivoting cover in the vertical position or remove it from the platform, when disconnecting the bungee cords.

LINQ ACCESSORIES

Only install accessories that are compatible with the LinQ anchor system. To use retractable LinQ anchors, lift them, making sure they are fully extended and locked. Refer to the accessory instruction sheet for proper installation. To lower the LinQ anchors when not in use, squeeze tabs then push down.



⚠ CAUTION

The LinQ attachment points are used to carry accessories and should always be retracted when not in use to reduce the risk of injury.

Stand clear of the swim platform when raising or lowering the integrated Rotax S engine. When tilted up, the outboard engine will push open the pivoting cover, creating a pinch point hazard. Personal injury can result from contact with the moving cover.

⚠ WARNING

Do not mount anything to the surface of the pivoting cover. Serious injury or death could occur from flying objects as a result of the outboard engine impacting an underwater object and forcing the pivoting cover open.



SECTION 9: TROUBLESHOOTING

This section will assist you in finding and correcting minor mechanical, electrical, and plumbing problems. If an engine problem is identified, consult your engine owner's manual. Some problems may require specialized tools; see your Alumacraft dealer.

GENERAL	
PROBLEM	THINGS TO DO
Boat lists to port or starboard at rest	<ol style="list-style-type: none"> 1. Redistribute load, move passengers to different seats 2. Check for water in bilge, run bilge pump
Boat lists or rolls on straight when heavily loaded	<ol style="list-style-type: none"> 1. Load not evenly distributed 2. Motor trim too far in 3. Water under cockpit floor
Boat porpoises (bow moves up and down on straight away)	<ol style="list-style-type: none"> 1. Motor trim too far out 2. Too much load in stern 3. Hull has a rocker
Boat is nose heavy and catches on turns	<ol style="list-style-type: none"> 1. Motor trimmed too far in, adjust trim out (up) 2. Too much weight in bow 3. Hull has a hook
Top speed too low with light load	<ol style="list-style-type: none"> 1. Excessive water in bilge or under floor 2. Boat is underpowered 3. Motor is damaged 4. Incorrect propeller or weeds on propeller 5. Incorrect trim adjustment 6. Marine growth on hull or outboard
Top speed too low with heavy load	<ol style="list-style-type: none"> 1. Excessive water in bilge or under floor. 2. Boat is underpowered 3. Motor is damaged 4. Incorrect propeller or weeds on propeller 5. Incorrect trim adjustment 6. Marine growth on hull or outboard
Boat gives rough ride in waves	<ol style="list-style-type: none"> 1. Speed too high for conditions 2. Improper trim adjustment 3. Too much weight in stern
Boat takes too long to come on plane with heavy load	<ol style="list-style-type: none"> 1. Incorrect propeller 2. Incorrect trim adjustment 3. Too much load in stern 4. Water under cockpit floor

GENERAL (CONT'D)

PROBLEM	THINGS TO DO
Boat gives a wet ride	<ol style="list-style-type: none"> 1. Too much weight forward 2. Motor trimmed too far in 3. Overloaded
Speed loss	<ol style="list-style-type: none"> 1. Water under cockpit floor 2. Marine growth on hull or lower unit 3. Weeds on propeller 4. Damaged propeller
Banks too much in turns	<ol style="list-style-type: none"> 1. Overloaded, improper weight distribution 2. Load too far forward 3. Motor trim too far in 4. Overpowered 5. Hull has a hook
Excessive cavitation	<ol style="list-style-type: none"> 1. Incorrect propeller 2. Motor too high on transom 3. Motor trim too far out 4. Load too far forward 5. Water under cockpit floor 6. Overpowered 7. Thru-hull fittings disturb water flow 8. Weeds on propeller

STEERING

PROBLEM	THINGS TO DO
Steering too loose/sloppy	<ol style="list-style-type: none"> 1. Cable transom bracket loose or badly worn 2. Steering wheel loose on helm 3. Worn or loose fasteners in helm unit or drive unit 4. Worn push/pull cable
Steering stiff or unusually hard operating, jerky or erratic	<ol style="list-style-type: none"> 1. Corrosive deposits at output end, either inside cable sleeve or inside motor tilt tube 2. Crushed or kinked cable conduit 3. Bent cable ram at output end 4. Friction device at helm overtightened 5. Internal corrosion or damage to cable 6. Engine and boat not trimmed out properly 7. Transom bracket improperly mounted, bent or distorted 8. Bent or distorted engine link may be interfering with engine

STEERING (CONT'D)

PROBLEM	THINGS TO DO
Steering system will not turn	<ol style="list-style-type: none"> 1. Corrosive buildup at output end of cables. WARNING! if system does not free easily, replace steering cables 2. System badly damaged at helm or cable output ends

LEAKS

PROBLEM	THINGS TO DO
Boat leaks [in-water checks]	<ol style="list-style-type: none"> 1. Visually inspect the engine mounting bolt holes, speedometer pick-up tube holes, and transducer screw mounting holes for any signs of leaking. 2. Remove the appropriate bolt or screw (out of the water), apply silicone sealant in the hole, replace bolt or screw, tighten and recheck. 3. Check livewell drain fittings and aerator pump fittings located in the transom area for any signs of leaking. 4. Inspect the hose fitting seals and tighten clamps if necessary.
Boat leaks [out-of-water checks]	<ol style="list-style-type: none"> 1. Water accumulated in the aft bilge area. First, dry up any accumulated water by opening the transom drain plug. Elevate the bow of the boat slightly to allow any water in the bilge area to run out the transom drain plug opening. Plug the livewell baitwells and fill them with water and note any signs of leakage in the fittings or hoses of this system. 2. If signs of leakage occur, trace the source of the problem and correct as required. 3. Drain the water from the livewells and baitwells and check the interior walls for signs of punctures. 4. Check the drain in the bottom of the wells and tighten, if necessary. 5. Check for cut or punctured hoses in the system 6. Contact your Alumacraft dealer.

ELECTRICAL

PROBLEM	THINGS TO DO
Lights, horn, or pumps do not work	<ol style="list-style-type: none"> 1. Battery discharged. 2. Check for blown main line fuse near positive battery terminal. 3. Check for blown component fuse at fuse panel. 4. Check battery terminal connections for proper electrical contact. 5. Check switch to make sure wires have not come loose from terminal spades. 6. Contact your Alumacraft dealer.
Indicator lights, gauges seem to operate erratically, illogically	<ol style="list-style-type: none"> 1. Check ground wire. 2. Check to be sure battery is properly connected. 3. Contact your Alumacraft dealer.
Aerator timer does not work	<p>Fixed interval timers without adjusting knob for the off time. Off time is pre-set at about 3 minutes, on time at about 1 minute.</p> <ol style="list-style-type: none"> 1. Check ground wire. 2. Check to be sure battery is properly connected. 3. Check to be sure red wire is properly connected to back of switch. 4. Contact your Alumacraft dealer.
Fuel gauge reads incorrectly or not at all	<ol style="list-style-type: none"> 1. Be sure boat is level (fuel gauge will only be accurate when the boat is in a level planning attitude). 2. Check ground on sending unit and ground on fuel gauge. 3. Check to be sure battery is properly connected and ignition is on. 4. Fuel gauge does not move when ignition is turned on; poor connection from sending unit (pink wire).
Tachometer problems	<ol style="list-style-type: none"> 1. Be sure battery is connected properly. 2. Check for good ground. 3. Make sure tachometer switch (on rear of tachometer) is set to match your motor (2 cylinder, 3 cylinder, 4 cylinder, etc.) 4. Check to be sure signal wire is properly connected. 5. Contact your Alumacraft dealer.

ELECTRICAL (CONT'D)

PROBLEM	THINGS TO DO
<p>Speedometer does not register or sticks during use</p>	<ol style="list-style-type: none"> 1. Slightly loosen nut(s) holding rear gauge clamp. Be sure speedometer now operates properly and is not loose in panel. 2. If the speedometer continues to stick, follow the tubing from the speedometer head to the pitot tube water pickup, checking for any sharp bends or kinks that may be impeding the air flow to or from the speedometer unit. Also check for blockage at the pitot tube inlet hole. Note: Compressed air at no more than 20 psi [1.4 bar] may be used to check speedometer movement for free operation. 3. If the unit is not registering at all, check for loose connections at pitot tube and the back of the speedometer. If loose connections are apparent, remove tubing from pitot tube or speedometer head respectively, cut back tubing approximately 0.5 in. [12.7 mm] with a sharp knife and reattach. No adhesive is recommended, as it can be introduced into the speedometer movement and cause a malfunction. 4. Contact your Alumacraft dealer.
<p>Fuel gauge sticks during operation or is inoperative.</p>	<ol style="list-style-type: none"> 1. Slightly loosen nuts holding back clamp and check operation. Make sure gauge now operates properly and is not loose in panel. 2. Make sure battery is properly connected and ignition switch is on. 3. Check ground connection. 4. Contact your Alumacraft dealer.

PLUMBING

PROBLEM	THINGS TO DO
<p>Pump runs but fails to function.</p>	<ol style="list-style-type: none"> 1. Make sure applicable valves are open. function. 2. Remove pump filter screen and inspect for clogs. Remove clogs and restart pump. Make sure pump impeller works and re-assemble unit. 3. Check input and output hoses for blockage and remove any clogs. 4. Contact your Alumacraft dealer.

MARINE WIRING COLOR CODE

COLOR	FUNCTION
RED	Main power feed, 2V positive
BLACK	Common ground, 12V negative
PURPLE	Ignition keyed power feed
GRAY	Fuse to stern light, tach sender
GRAY/WHITE	Fuse to bow light
BROWN	Fuse to bilge pump
BROWN/WHITE	Fuse to aerator pump
BLUE	Interior courtesy lights
GREEN	Fuel system bond wire
YELLOW/RED	Starting circuit
PINK	Fuel sender to gauge
BROWN/RED	Recirculating pump
BROWN/BLUE	Recirculating pump
ORANGE/WHITE	Horn
ORANGE	Accessory
PURPLE/RED	Radio

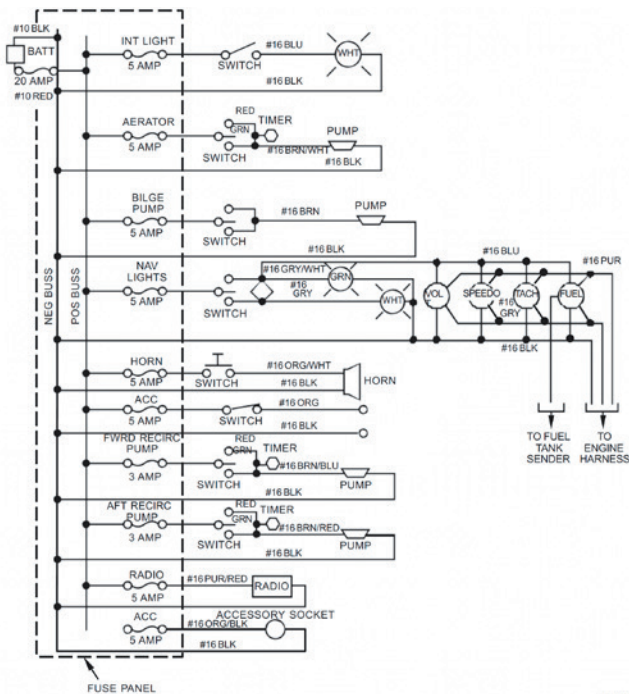

ALUMA7

SECTION 10: GLOSSARY OF TERMS

THE FOLLOWING TERMS ARE COMMONLY USED BOATING TERMS PRESENTED IN THE OPERATOR'S GUIDE AND ARE PROVIDED FOR YOUR REFERENCE.

ABOARD - On or in the boat.

AFLOAT - On the water.

AFT - Toward the rear or stern of the boat.

AGROUND - Touching bottom.

AMIDSHIP - Center or middle of the boat.

ANCHOR - [1] An iron casting shaped to grip the lake bottom to hold the boat. [2] The act of setting the anchor.

ASTERN - Toward the stern.

BAIL - To remove water from the bottom of the boat with a pump, bucket, sponge, etc.

BAITWELL - A miniature livewell used to store and keep live bait alive and healthy.

BEAM - The widest point on the boat.

BEARING - Relative position or direction of an object from the boat.

BILGE - The lowest interior section of the boat hull.

BILGE KEELS - The raised areas or aluminum extrusions on the bottom of a boat that parallel the keel.

BOARDING - To enter the boat.

BOUNDARY WATERS - A body of water between two areas of jurisdiction; i.e., a river between two states.

BOW - The front of the boat.

BULKHEAD - Vertical partition (wall) in a boat.

BUNKS - Carpeted trailer hull supports.

BURDENED BOAT - Term for the boat that must "give-way" to boats with the right-of-way.

CAPACITY PLATE - A plate that provides maximum weight capacity and engine horsepower rating information. It is located in full view of the helm.

CAPSIZE - To turn over.

CAST-OFF - To unfasten mooring lines in preparation for departure.

CENTER LINE - A lengthwise imaginary line which runs fore and aft with the boat's keel.

CHINE - The point on a boat where the side intersects (meets) the bottom.

CLEAT - A deck fitting with ears to which lines are fastened.

CONSOLE - Also called helm. The steering wheel area of the boat.

CRANKING BATTERY - The main battery used for engine starting and electrical circuits.

CURRENT - Water moving in a horizontal direction.

DECK - The open surface on the boat where the passengers walk.

DEEP CYCLE BATTERIES - Special long-running batteries which can be repeatedly discharged and recharged without significant loss of power.

DOLLY WHEEL - A rolling jack assembly at the front of the trailer used for positioning the coupler during trailer hookup.

DRAFT - The depth of the boat below the water line, measured vertically to the lowest part of the hull.

ELECTROLYSIS - The break-up of metals due to the effects of galvanic corrosion.

FATHOM - Unit of depth or measure; 1 fathom equals 6 feet.

FENDERS - Objects placed alongside the boat for cushioning.

FORE - Toward the front or bow of the boat. Opposite of aft.

FREEBOARD - The distance from the water to the gunwale.

FUEL SENDING UNIT - The electrical device that is mounted on the outside of a built-in fuel tank and controls the dashboard fuel gauge.

GIVE-WAY BOAT - [1] Term for the boat that must take whatever action necessary to keep well clear of the boat with the right-of-way in meeting or crossing situations. [2] The burdened boat.

GUNWALE - The rail or upper edge of a boat's side.

HEAD - A marine toilet.

HELM - The steering wheel or command area.

HULL - The body of the boat.

HYPOTHERMIA - A physical condition where the body loses heat faster than it can produce it.

IN-LINE FUSE - A type of protective fuse located in the power wire of a direct current (DC) circuit usually near the battery.

KEEL - The lowest portion of the boat; extends fore and aft along the boat's bottom.

LIST - Leaning or tilt of a boat toward the side.

MAKING WAY - Making progress through the water.

MARINE CHART - Seagoing maps showing depths, buoys, navigation aids, etc.

MOORING - An anchor, chain, or similar device that holds a boat in one location.

NAVIGATION AID - Recognizable objects on land or sea such as buoys, towers or lights which are used to fix position to identify safe and unsafe waters.

NO-WAKE SPEED - The speed at which a boat travels to produce an imperceptible wake usually less than 5 mph.

PFD - Personal flotation device.

PITOT TUBE - See SPEEDOMETER PICKUP TUBE.

PLANING HULL - A hull designed to lift, thereby reducing friction and increasing efficiency.

PORPOISE - A condition in which the bow bounces up and down caused by trimming the engine too far out.

PORT - [1] The left side of a boat when facing the bow [while inside the boat]. [2] A destination or harbor.

PRIVILEGED BOAT - Term used for the boat with the right-of-way.

RIGHT-OF-WAY - Term for the boat that has priority in meeting or crossing situations. The stand on or privileged boat.

RULES OF THE ROAD - Regulations for preventing collisions on the water.

SPEEDOMETER PICKUP TUBE - Also called pitot tube. The plastic device that is mounted on the lower exterior transom and extends below the bottom of the boat. It connects to the speedometer with plastic flexible tubing.

SPLASHWELL - The section of an outboard-equipped boat that is just forward of the transom.

STAND ON BOAT - Term for the boat that must maintain course and speed in meeting or crossing situations. The privileged boat.

STARBOARD - The right side of the boat when looking towards the bow [while inside the boat].

STERN - The back of the boat.

STOW - To pack the cargo.

SURGE BRAKES - A type of trailer braking system designed to automatically actuate when the tow vehicle's brakes are applied.

TRANSDUCER - The unit that sends/receives signals for the depth sounder.

TRANSOM - The transverse beam across the stern.

TRIM - Fore to aft and side to side balance of the boat when loaded.

UNDERWAY - Boat in motion; i.e., not moored or anchored.

WAKE - The waves that a boat leaves behind when moving through the water.

WATERWAY - A navigable body of water.

V-PAD - A modified vee hull design with a small, flat area in the keel aft.

VISUAL DISTRESS SIGNAL - A device used to signal the need for assistance such as flags, lights and flares.



BRP REIMAGINES THE WAY YOU ACCESS YOUR WORLD

Alumacraft is one of many success stories from BRP, the global company behind some of the most daringly innovative products and experiences that move you. Because it's not about the destination, it's about the journey – yours.

Discover our brands:

***ski-doo* LYNX SEA-DOO CAN-AM ROTAX ALUMACraft. MANITOU. QUINTREX**

www.brp.com

