

LYNX®



UTILITY ACE SERIES

OPERATOR'S GUIDE

Includes Safety, Use and Maintenance
Information

2024



⚠ WARNING

Read this guide thoroughly. It contains important safety information.
Minimum recommended operators age: 16 years old.
Keep this operator's guide with the vehicle at all times.

619901020

Original
Instructions

 **WARNING**

This vehicle may exceed the performance of other vehicles you may have ridden in the past. Take time to familiarize yourself with your new vehicle.

In Canada, products are distributed and serviced by Bombardier Recreational Products Inc. (BRP).

In the USA, products are distributed and serviced by BRP US Inc.

In the European Economic Area (which is comprised of the member states of the European Union plus the United Kingdom, Norway, Iceland and Liechtenstein), the Commonwealth of the Independent States (including Ukraine and Turkmenistan) and Turkey, products are distributed and serviced by BRP European Distribution S.A. and other affiliates or subsidiaries of BRP.

For all other countries, products are distributed and serviced by Bombardier Recreational Products Inc. (BRP) or its affiliates.

™® Trademarks of BRP or its affiliates.

This is a non-exhaustive list of trademarks that are the property of Bombardier Recreational Products Inc. or its affiliates. Trademarks may not be registered in every jurisdictions:

ACE™

D.E.S.S.™

HPG™

iTC™

LYNX®

ROTAX®

XPS®

All rights reserved. No parts of this guide may be reproduced in any form without the prior written permission of Bombardier Recreational Products Inc.

©Bombardier Recreational Products Inc. (BRP) 2023

Deutsch	Dieses Handbuch ist möglicherweise in Ihrer Landessprache verfügbar. Bitte wenden Sie sich an Ihren Händler oder besuchen Sie: www.operatorsguides.brp.com
English	This guide may be available in your language. Check with your dealer or go to: www.operatorsguides.brp.com
Español	Es posible que este manual esté disponible en su idioma. Consulte a su distribuidor o visite: www.operatorsguides.brp.com
Français	Ce guide peut être disponible dans votre langue. Vérifier avec votre concessionnaire ou aller à: www.operatorsguides.brp.com
Italiano	Questa guida potrebbe essere disponibile nella propria lingua. Contattare il concessionario o consultare: www.operatorsguides.brp.com
中文	本手册可能有您的语种的翻译版本。请向经销商询问，或者登录 www.operatorsguides.brp.com 查询。
日本語	このガイドは、言語によって翻訳版が用意されています。ディーラーに問い合わせるか、次のアドレスでご確認ください： www.operatorsguides.brp.com
Nederlands	Deze handleiding kan beschikbaar zijn in uw taal. Vraag het aan uw dealer of ga naar: www.operatorsguides.brp.com
Norsk	Denne boken kan finnes tilgjengelig på ditt eget språk. Kontakt din forhandler eller gå til: www.operatorsguides.brp.com
Português	Este manual pode estar disponível em seu idioma. Fale com sua concessionária ou visite o site: www.operatorsguides.brp.com
Русский	Воспользуйтесь руководством на вашем языке. Узнайте о его наличии у дилера или на странице по адресу www.operatorsguides.brp.com
Suomi	Käyttöohjekirja voi olla saatavissa omalla kielelläsi. Tarkista jälleenmyyjältä tai käy osoitteessa: www.operatorsguides.brp.com
Svenska	Denna bok kan finnas tillgänglig på ditt språk. Kontakta din återförsäljare eller gå till: www.operatorsguides.brp.com

Models	Package	Engine
49 Ranger	STD	600 ACE
	ST	900 ACE
		900 ACE Turbo
59 Ranger	STD	600 ACE
69 Ranger	STD	900 ACE
	LTD	900 ACE Turbo
	SnowCruiser	900 ACE Turbo R

TABLE OF CONTENTS

GENERAL INFORMATION

KNOW BEFORE YOU GO	11
SAFETY MESSAGES	12
ABOUT THIS OPERATOR'S GUIDE	13
RESPECT OF THE ENVIRONMENT	14

SAFETY INFORMATION

BEFORE YOU GO	18
Operating Age and Ability	18
Drugs and Alcohol	18
Avalanche Safety Training Courses	18
Protective Gear	19
Required Equipment	19
GET FAMILIAR WITH THE SNOWMOBILE	21
Track Propulsion System	21
Steering	21
Tether Cord	22
Braking	22
Parking Brake	22
Programmable D.E.S.S. Key	22
Carrying Loads	23
Towing Loads	23
Towing Another Snowmobile	24
Accessories and Modifications	25
Traction Enhancing Products	25
RIDE SAFELY	29
Rider Position (Forward Operation)	29
Rider Position (Reverse Operation)	31
Riding with Passenger(s)	32
Riding Alone	33
Riding in a Group	33
Avoiding Collisions	35
Riding Behaviors	35
Speeding	36
Moving Parts	36
Know Terrain and Riding Variations	36
Respect of the Wildlife	40
Carbon Monoxide (CO) Poisoning	40
Gasoline Fires and Other Hazards	41
Burns from Hot Parts	41
PRACTICE EXERCISES	42
Where to Practice Exercises	42
Exercises to Practice	42
FUELING	45
Fueling Procedure	45

TABLE OF CONTENTS

TRANSPORTING THE VEHICLE	46
IMPORTANT ON-PRODUCT LABELS	47
Vehicle Safety Labels	47
Technical Information Labels	80
PRE-RIDE INSPECTION	83
Before Starting the Engine	83
After Engine is Started	83
Pre-Ride Check List	84

VEHICLE INFORMATION

PRIMARY CONTROLS	88
Handlebar	88
Throttle Lever	88
Emergency Engine Stop Switch	91
Brake Lever	93
Parking Brake Lever	99
Engine Cut-off Switch	101
SECONDARY CONTROLS	104
Handlebar Multifunction Switch	104
Driving Modes	110
Heated Seat Switch (if equipped)	113
Gearshift Lever	113
Reverse Lever (if equipped)	115
Horn Button (if equipped)	115
Passenger Heated Grip Switch (if equipped)	116
Passenger Heated Seat Switch (if equipped)	117
BODY AND SEAT	118
Windshield	118
Front Storage Compartment	121
Hood	122
Side Panels	124
Upper Body Module	128
Seat	133
EQUIPMENT	142
Operator's Guide	142
Power Outlet - USB (if equipped)	142
Adjustable Mirrors (if equipped)	142
Mountain Strap	143
Electric Visor Jack Connector	144
Drive Belt Guard	144
Spare Drive Belt Holder	149
Tools	151
Rear Storage Compartment (if equipped)	153
Cargo Box (if equipped)	156
Hitch	158
GAUGE – 4.5" DIGITAL DISPLAY	160
Multifunction Display	160

Warning Lamps and Indicators	163
Settings	165
GAUGE – 7.2" DIGITAL DISPLAY	167
Multifunction Display	167
Warning Lamps and Indicators	171
Settings	173
FUEL	174
Fuel Requirements	174
Fueling Procedure	175
ENGINE OIL	177
Recommended Oil	177
BREAK-IN PERIOD	178
Operation During Break-In	178
BASIC PROCEDURES	179
Engine Starting Procedure	179
Emergency Starting	179
Vehicle Warm-Up	179
Shifting in High or Low range	180
Shifting in Reverse	181
Shifting in Forward from Reverse	183
Shutting Off the Engine	183
RIDING CONDITIONS AND YOUR SNOWMOBILE	184
Altitude	184
Temperature	184
Hard Packed Snow	184
TUNE YOUR RIDE	186
Front Suspension Adjustments	186
Rear Suspension Adjustments	190
Adjustment Tips According to Vehicle Behavior	200

MAINTENANCE

MAINTENANCE SCHEDULE	202
EPA Regulation - Canadian and USA Vehicles	202
Trail/ Crossover/ Utility Usage	203
Maintenance Schedule	204
MAINTENANCE PROCEDURES	213
Engine Coolant	213
Engine Oil	214
Engine Oil Filter	221
Exhaust System	223
Spark Plugs	224
Brake Fluid	224
Chaincase Oil	227
Gearbox Oil	231
Drive Chain	235
Drive Belt	236
Track	240

TABLE OF CONTENTS

Suspension	249
Skis	252
Fuses	252
Headlights	255
Battery	259
VEHICLE CARE	267
Post-Operation Care	267
Vehicle Cleaning and Protection	267
STORAGE	268
PRESEASON PREPARATION	269
MAINTENANCE RECORDS	270

TECHNICAL INFORMATION

VEHICLE IDENTIFICATION	280
Vehicle Description Decal	280
Identification Numbers	280
COMPLIANCE LABELS	282
Regulation (EU) 2016/1628 applicable for Non-Road Mobile Machineries	283
NOISE EMISSION AND VIBRATION VALUES	285
UK DECLARATION OF CONFORMITY	286
EU DECLARATION OF CONFORMITY	287
RADIO FREQUENCY DIGITALLY ENCODED SECURITY SYS- TEM (RF D.E.S.S. KEY)	288
MULTIFUNCTION GAUGE REGULATORY INFORMATION	289

TECHNICAL SPECIFICATIONS

ENGINE	294
600 ACE	294
900 ACE	295
900 ACE Turbo	297
900 ACE Turbo R	299
VEHICLE	301
49 Ranger	301
59 Ranger	306
69 Ranger	310

TROUBLESHOOTING

TROUBLESHOOTING-GUIDELINES	318
MONITORING SYSTEM	321
Pilot Lamps, Messages and Beeper Codes	321
Fault Codes	325

WARRANTY

BRP INTERNATIONAL LIMITED WARRANTY: 2024 LYNX® SNOWMOBILES	328
SCOPE OF THE LIMITED WARRANTY	328
LIMITATIONS OF LIABILITY	328
EXCLUSIONS – ARE NOT WARRANTED	329
WARRANTY COVERAGE PERIOD	329
CONDITIONS TO HAVE WARRANTY COVERAGE	330
WHAT TO DO TO OBTAIN WARRANTY COVERAGE	331
WHAT BRP WILL DO	331
TRANSFER	331
CONSUMER ASSISTANCE	332
BRP LIMITED WARRANTY FOR THE EUROPEAN ECONOMIC AND THE COMMONWEALTH OF THE INDEPENDENT STATES (CIS) AREAS AND TURKEY: 2024 LYNX® SNOWMOBILES ..	333
SCOPE OF THE LIMITED WARRANTY	333
LIMITATIONS OF LIABILITY	333
EXCLUSIONS – ARE NOT WARRANTED	334
WARRANTY COVERAGE PERIOD	334
CONDITIONS TO HAVE WARRANTY COVERAGE	335
WHAT TO DO TO OBTAIN WARRANTY COVERAGE	335
WHAT BRP WILL DO	336
TRANSFER	336
CONSUMER ASSISTANCE	336

CUSTOMER INFORMATION

DATA PRIVACY INFORMATION	340
CONTACT US	342
Asia Pacific	342
Europe, Middle East and Africa	342
Latin America	343
North America	343
CHANGE OF ADDRESS/OWNERSHIP	344

This page is intentionally blank

GENERAL INFORMATION

Congratulations on your purchase of a new BRP snowmobile. Whatever model you have chosen, it is backed by the Bombardier Recreational Products Inc. (BRP) warranty and a network of authorized BRP snowmobile dealers ready to provide the parts, service or accessories you may require.

Your dealer is committed to your satisfaction. He has taken training to perform the initial set-up and inspection of your snowmobile as well as completed the final adjustment required to suit your specific weight and riding environment before you took possession.

At delivery, you were informed of the warranty coverage and signed the Pre-delivery Check List to ensure your new vehicle was prepared to your entire satisfaction.

KNOW BEFORE YOU GO

To learn how to reduce the risk for you, your passenger or bystanders being injured or killed, read the following sections before you operate the vehicle:

- *safety information*
- *vehicle information.*

Also read all safety labels on your snowmobile and watch attentively your safety video located at:

[www. brplynx. com/gb/en/owner-zone/safety/safety-information.html](http://www.brplynx.com/gb/en/owner-zone/safety/safety-information.html) -.

Or, use the following QR code.



SAFETY MESSAGES

This operator's guide utilizes the following symbols and words to emphasize particular information:

The safety alert symbol  indicates a potential injury hazard.

WARNING

Indicates a potential hazard which, if not avoided, could result in serious injury or death.

CAUTION

Indicates a hazard situation which, if not avoided, could result in minor or moderate injury.

NOTICE

Indicates an instruction which, if not followed, could severely damage vehicle components or other property.

ABOUT THIS OPERATOR'S GUIDE

This operator's guide has been prepared to acquaint the owner, operator and passenger with this snowmobile and its various controls, maintenance and safe riding instructions.

The following terminology in regards to operator, passenger and vehicle configuration is used as follows throughout this guide:

- **Operator:** refers to the person being behind the controls and driving the snowmobile.
- **Passenger:** refers to a person sitting behind the operator.
- **1-UP:** refers to a model designed for an operator only.
- **2-UP:** refers to a model designed to accommodate **one** passenger.

Keep this operator's guide in the vehicle as you can refer to it for the operation, instructing others, maintenance and troubleshooting.

Note that this guide is available in several languages. In the event of any discrepancy, the English version shall prevail.

If you want to view and/or print an extra copy of your operator's guide, simply visit the following website:

www.operatorsguides.brp.com

The information contained in this document is correct at the time of publication. BRP, however, maintains a policy of continuous improvement of its products without imposing upon itself any obligation to install them on products previously manufactured. Due to late changes, some differences between the manufactured product and the descriptions and/or specifications in this guide may occur. BRP reserves the right at any time to discontinue or change specifications, designs, features, models or equipment without incurring any obligation upon itself.

This operator's guide should remain with the vehicle when it's sold.

RESPECT OF THE ENVIRONMENT

The guidelines that we support are not designed to limit your snowmobiling fun, but to preserve the beautiful freedom that you can experience only on a snowmobile! These guidelines will keep snowmobilers healthy, happy and able to introduce others to what they know and enjoy about their favorite winter pastime. So, the next time you hit the trails on a cool, crisp and clear winter day, we ask you to remember that you are paving the way for the future of our sport. Help us lead it down the right path! From all of us at BRP, thank you for doing your share.

There is nothing more exhilarating than snowmobiling. Venturing onto snowmobile trails that cross wild areas is an exciting and healthy winter sport. However, as the number of people using these recreational parks increases, so does the potential for damage to the environment. Abuse of land, facilities and resources inevitably leads to restrictions and closures of both private and public land.

In essence, the greatest threat to our sport, is all around us. Which leaves us with one logical choice. When we snowmobile, we must always ride responsibly.

The vast majority respect the law and the environment. Each of us must set an example for those who are new to the sport, young and old alike.

It is in every one's best interest to tread lightly into our recreational areas. Because, in the long run, to protect the sport we must preserve the environment.

Recognizing the importance of this issue and the need for snowmobilers to do their share in preserving areas that make it possible to enjoy our sport, BRP has developed the "Light Treading Is Smart Sledging" campaign for snowmobilers.

Light Treading refers to more than the thread of our tracks. It's a statement of concern, respect and willingness to take the lead and take action. It applies to the environment in general, its proper care and maintenance, its natural inhabitants and all enthusiasts and the public at large who enjoy the great outdoors. With this theme, we invite all snowmobilers to remember that respecting the environment is not only critical to the future of our industry but to future generations.

Light Treading in no way suggests you should curb your appetite for snowmobiling fun! It simply means tread with respect!

The fundamental objective of Light Treading is one of respect for where and how you ride a snowmobile. You're a light treader when you follow the principles below.

Become informed. Obtain maps, regulations and other information from the Forest Service or from other public land agencies. Learn the rules and follow them and that goes for speed limits, too!

Avoid running over young trees, shrubs, and grasses and don't cut wood. On flatlands or areas where trail riding is popular, it's important to ride only where authorized. Remember, there is a link between protecting your environment and your own safety.

Respect wildlife and be particularly sensitive of animals that are rearing young or suffering from food shortage. Stress can sap scarce energy reserves. Refrain from riding in areas where only animals are intended to tread!

Obey gate closures and regulatory signs and remember, light treaders don't litter!

Stay out of wilderness areas. They're closed to all vehicles. Know where the boundaries are.

Obtain permission to travel across private land. Respect the rights of landowners and other people's privacy. Remember, snowmobile technology has lowered the noise factor considerably, but you still shouldn't rev your engines where quiet "is the order of the day".

Snowmobilers know all too well the efforts that have been made throughout the sport's history to enjoy access to areas where people can snowmobile safely and responsibly. This effort continues today, as strong as ever.

Respecting the areas where we ride... wherever they may be... is the only way to ensure their future enjoyment. That's one major reason why we know you'll agree that Light Treading is smart sledding! And there are more.

Enjoying the opportunity to see winter and all its natural majestic wonders, is an experience cherished by snowmobilers. Light Treading will preserve this opportunity and will make it possible for us to expose others to the beauty of winter and the unique thrill of our sport! Light Treading will help our sport to grow!

Finally, Light Treading is the sign of a smart snowmobiler. You don't have to leave big tracks or careen through a virgin forest to show you can ride. So whether you're driving a high performance BRP snowmobile or any other make or model, show you know what you're doing. Show you know how to send snow flying and make tracks with a light touch!

This page is intentionally blank

SAFETY INFORMATION

BEFORE YOU GO

WARNING

Disregarding any of the safety precautions and instructions contained in this section could cause injury including the possibility of death.

Operating Age and Ability

Operators must be qualified. Make sure the operator is 16 or older. Your state (or province) may have additional requirements. Laws regarding the minimum age and licensing requirements vary from one jurisdiction to another. Be sure to contact the local authorities for information regarding the legal operation of a snowmobile in the intended jurisdiction of use. BRP highly recommends that you take a safety riding course. Basic training is required for the safe operation of any snowmobile.

Operation of this snowmobile with a disability that impairs vision, reaction time, judgment, or operation of the controls is not recommended. The safe use of your snowmobile depends on many conditions such as visibility, speed, weather, environment, traffic, vehicle condition and the condition of the operator. The performance of some snowmobiles may significantly exceed that of other snowmobiles you have operated. Therefore, use by novice or inexperienced operators is not recommended.

Each passenger must be able to simultaneously place both feet firmly flat against each footboard when properly seated.

Drugs and Alcohol

Never ride after consuming alcohol or drugs. Riding on a snowmobile requires the operator and passenger (s) to be sober, attentive and alert. The use of drugs and alcohol, singly or in combination, decreases reaction time, impedes judgment, impairs vision, and inhibits your ability to safely ride on a snowmobile.

Avalanche Safety Training Courses

We recommend that all mountain riders take a local avalanche safety training course to become more familiar with snow conditions and learn how to properly use their equipment. Here are some web sites that can help you finding important information:

- - US: www.avalanche.org
- - Europe: www.avalanches.org
- - Canada: www.avalanche.ca

Protective Gear

Proper snowmobile clothing should be worn by all riders. It should be comfortable and not too tight. Always check the weather forecast before going on a ride. Dress for the coldest weather expected. Thermal underwear next to the skin also provides a good insulation.

Always wear an approved helmet at all times for safety and comfort. They provide both warmth and reduce injury. A stocking type cap, balaclava and face mask should always be carried or worn. Goggles or a face shield that attach to the helmet are indispensable.

Hands should be protected by a pair of snowmobile gloves or mitts which have sufficient insulation and allow use of thumbs and fingers for operation of controls.

Rubber bottom boots with either a nylon or a leather top, with removable felt liners are best suited for snowmobiling.

You should keep yourself as dry as possible when snowmobiling. When you come indoors, take your snowmobile suit and boots off and make certain they dry properly.

Do not wear a long scarf or loose apparels that could get caught in moving parts.

Carry colored lens goggles.

Required Equipment

As the owner of the snowmobile, you are responsible for ensuring that all required safety equipment is aboard. Check your local regulations about requirements.

First aid kit	Provided tool kit
Mobile phone	Knife
Spare spark plugs	Flashlight
Adhesive tape (duct tape)	Trail map
Spare drive belt	Snack
Probe*	Shovel*

Avalanche beacon*	-
*When riding in an area with avalanche risk	

GET FAMILIAR WITH THE SNOWMOBILE

This vehicle may exceed the performance of other vehicles you may have ridden. Take time to familiarize yourself with your new vehicle.

Inexperienced riders may overlook risks and be surprised by vehicle's specific behavior and terrain conditions. Ride slowly. Excessive speed and reckless driving can kill.

Make sure you read and understand the content of this operator's guide to become completely familiar with the controls and operation of the snowmobile before embarking on your first trip or taking on a passenger(s). If you have not had the opportunity to do so, practice driving solo in a suitable traffic-free area to become accustomed to the feel and response of each control.

It is very important to inform any operator, regardless of his experience, of the handling characteristics of this snowmobile. The snowmobile configuration, such as ski stance, ski type, suspension type, track length, width and type vary from a model to another. The snowmobile handling is greatly influenced by these characteristics.

Track Propulsion System

Your snowmobile features a track propulsion system. The track grips on the snow-covered surface and pushes the snowmobile in the opposite direction of the force applied on the surface. Stay away from the track. Personal injury will result if contact is made with the revolving track.



WARNING

Never stand behind or near a rotating track. Debris could be projected causing severe injuries.

The grip of the track will vary depending on the surface conditions. The grip may be reduced on hard-pack snow or ice. Reduce your speed and allow more space to turn. Refer to the *TRACTION ENHANCING PRODUCTS* subsection of this guide to learn how to balance the grip of the ski vs the grip of the track. If the front and rear of the snowmobile are out of balance due to an incorrect combination of traction enhancing products, the snowmobile may tend to oversteer or understeer, which could lead to a loss of control.

Steering

Skis are used to steer the snowmobile through the handlebar. The performance to steer will vary depending of the grip of the skis on the surface. Steering control ability may be reduced on hard-pack snow, ice or roads. Reduce speed and allow more space to turn. Refer to the *TRACTION ENHANCING PRODUCTS* subsection of this guide to learn how to balance the grip of the ski versus the grip of the track. If

the front and rear of the snowmobile are out of balance due to an incorrect combination of traction enhancing products, the snowmobile may tend to oversteer or understeer, which could lead to a loss of control.

Riding with a passenger or when carrying loads, the steering control will also be reduced. Reduce speed and allow more space to turn.

Tether Cord

Always attach tether cord eyelet to clothing before starting the engine to help ensure the engine stops should the operator fall off.

After riding, always remove the tether cord from the engine cut-off switch to avoid unauthorized use by children or others and to prevent starting in a closed environment (ex: garage).

Braking

Braking performances may vary suddenly under certain conditions. Always remember that the snowmobile braking distance may be affected when riding with a passenger and when loaded with cargo at the rear. Never jam the brake and lock the track. Be sure to use restraint in braking to keep from blocking the track in order to avoid surprises that could lead to a loss of control.

Using studs on the track will give you better braking capacity on packed snow or ice but will have no noticeable effect on soft snow. Refer to *Enhancing Traction Control Products* subsection for track stud application.

Parking Brake

Always engage parking brake before starting the engine. Parking brake should be used whenever snowmobile is parked.

Make sure parking brake is fully disengaged before operating the snowmobile. When you ride the vehicle, brake pads that are caused to drag by a continuous pressure on the lever may cause damage to the brake system and cause loss of braking capacity or fire.

Programmable D.E.S.S. Key

The Programmable D.E.S.S. Key can be programmed to limit the speed of the snowmobile and the engine torque. Enabling first time users and less experienced operators to learn how to operate while gaining the necessary confidence and control.

Visit your BRP authorized dealer to see if this accessory is available for your model.

Carrying Loads

Carrying loads affects the vehicle handling, stability and braking distance. Appropriate loading and weight distribution are therefore important.

When carrying loads it is very important to follow the recommendations:

- Never exceed the maximum cargo capacity. Refer to *Safety Information on the Vehicle* or *Technical Specifications* subsections for the applicable cargo load capacity of your snowmobile.
- Always adjust the suspensions according to the cargo load. Refer to *Tune Your Ride* subsection for more details.
- Never carry a load unless it is properly secured using a BRP LinQ certified accessory. Compatible accessories which are not BRP certified may not be considered as fit for this purpose.
- Always reduce your speed, turn gradually and allow longer braking distance when carrying loads.

WARNING

Failure to follow these recommendations when carrying or towing loads could lead to a loss of control and possibly in a tip over.

Towing Loads

Towing loads affects the vehicle handling, stability and braking distance. Appropriate loading and weight distribution are therefore important.

When towing a load it is very important to follow the recommendations:

- Always use a rigid tow bar to tow a cargo carrier or an accessory.
- Never tow a load using a rope. Using a rope would result in a collision between the load and the snowmobile and possibly in a tip over in case of a rapid deceleration or on a downward slope.
- Never tow a load by attaching it directly to the bumper. Use only the hitch to tow a load. Make sure that the cargo carrier hitch is compatible with the one on the vehicle. Use security chains or cables to secure the cargo carrier with the vehicle. Avoid excessive slack in the chains or cables, it could break and snap back.
- Never exceed the vehicle maximum tow capacity. Refer to *Safety Information on the Vehicle* or *Technical Specifications* subsections for the applicable towing capacity of your snowmobile.
- Never exceed the tongue weight capacity, if applicable.
- Always make sure load is evenly distributed and safely secured on the cargo carrier. Make sure there is at least some weight on the tongue, if applicable.

- Always adjust the suspensions according to the weight on the tongue, if applicable. Refer to *Tune Your Ride* subsection for more details.
- Reduce your speed and turn gradually. Avoid hills and rough terrain. Riding this vehicle with a cargo carrier substantially increases the risk of toppling, especially on inclined slopes. Never attempt steep hills.
- Allow more distance for braking, especially on inclined surfaces and when a passenger is on board. Be careful not to skid or slide.
- Use caution when disconnecting a loaded cargo carrier; its load may topple on you or others.

 **WARNING**

Failure to follow these recommendations when carrying or towing loads could lead to a loss of control and possibly in a tip over.

On vehicle equipped with a gearbox, always put the shift lever to L (low range) when towing a cargo carrier.

Any towed accessory should have reflectors on both sides and at the rear.

Check country transport regulations for brake light(s) requirements.

Towing Another Snowmobile

If a snowmobile is disabled and must be towed, in an emergency situation only, a rope can be used

- Remove the drive belt. Refer to *Maintenance Procedures* for more details.
- Attach the rope to the ski legs (spindles), **not** to the skis. If the ski legs are not accessible, attach the rope to the bumper.
- Have someone sit on the towed snowmobile to steer and activate the brake if needed.
- Tow at low speed with extra caution.

NOTICE

Always remove the drive belt of the snowmobile that is to be towed to prevent damage to its belt and drive system.

In some areas, it may be illegal to do so. Check with state or local authorities.

Accessories and Modifications

Any modifications or addition of accessories approved by BRP may affect the handling of your vehicle. It is important to take the time to get familiar with the vehicle once modifications are made to understand how to adapt your driving behavior accordingly.

Avoid installing equipment not specifically approved by BRP for the vehicle and avoid unauthorized modifications. These modifications and equipment have not been tested by BRP and may create hazards. For example, they could:

- Create a loss of control and increase risk of crash
- Cause overheating or short circuits increasing the risk of fire or burn injuries
- Affect the protection features provided by the vehicle
- Affect the behavior of the trailer when the vehicle is transported
- Cause a risk of losing objects on the road when transported.

Your vehicle may also become illegal to ride.

Ask your authorized BRP dealer for suitable available accessories for your vehicle.

Traction Enhancing Products

NOTE:

This section is applicable to all snowmobile models that are either equipped with a:

- Factory installed track approved by BRP for special studs installation.
- Factory pre-studded track.

or that can received one of these tracks.

Always refer to your authorized BRP snowmobile dealer to learn more on traction enhancing products and applicability on your snowmobile.

Using traction enhancing products such as, adjustable or more aggressive ski carbide runners and / or track studs on your snowmobile will change its behavior, particularly in terms of maneuverability, acceleration, and braking.

Using traction enhancing products gives a better grip on hard packed snow and ice, but has no noticeable effect in deep snow. For this reason, driving a snowmobile equipped with traction enhancing products requires a certain adaptation period. If your snowmobile is equipped with traction enhancing products, be sure to take plenty of time to get used to the way it handles when turning, accelerating, and braking.

The use of track studs can increase the load and the stress on certain snowmobile components, as well as the vibration level. This can cause premature wear on parts such as belt, brake linings, bearings, chain, chain sprockets, and shorten track life.

Track studs can also cause serious damage to your snowmobile if it is not equipped with the appropriate tunnel protectors.

Check local regulations concerning the use of traction enhancing products on snowmobiles.

Studding an unapproved track or using unapproved studs increase the risk of the track tearing or severing

Installing track studs and tunnel protector(s) requires technical knowledge. To ensure safe and proper installation, BRP recommends to have the studs installed by your dealer.

For maintenance and replacement refer to *Track* in *Maintenance Procedures*.

Maneuverability

Using traction enhancing products such as, more aggressive ski carbide runners and/or studs makes the snowmobile grip the ground better at both the front and at the rear. The use of carbide runners is therefore required to give the skis a better grip, so that the front and rear of the snowmobile are in balance. While off-the-shelf carbide ski runners are adequate, they don't necessarily give you optimal control, since that depends on your personal preferences, your riding style, and how your suspension is adjusted.

 WARNING
If the front and rear of the snowmobile are out of balance due to an incorrect combination of traction enhancing products, the snowmobile may tend to oversteer or understeer, which could lead to a loss of control.

Oversteering

In certain conditions, using more aggressive ski carbide runners without studs on the rear track could make the snowmobile prone to oversteering, see illustration.

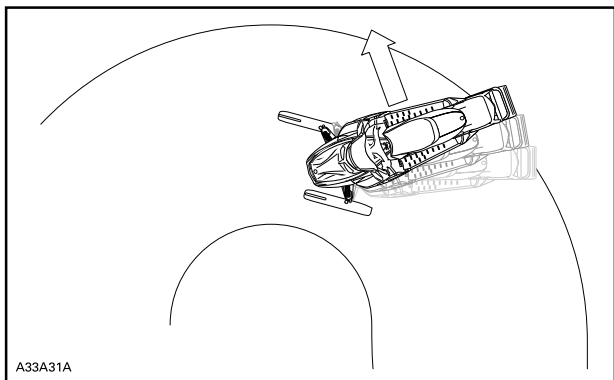
**OVERSTEERING****Understeering**

In certain conditions, the use of studs on the track could make the snowmobile prone to understeering if the skis are not equipped with more aggressive ski carbide runners, see illustration.

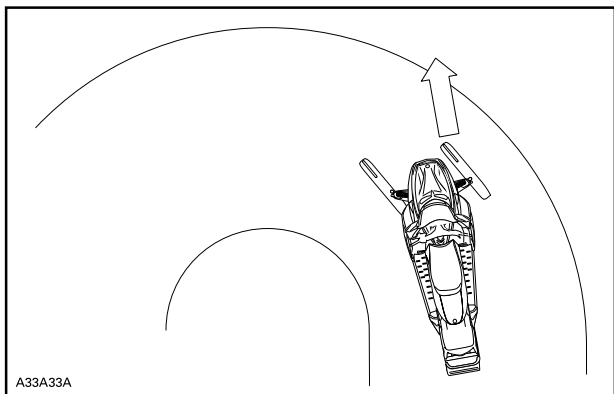
**UNDERSTEERING**

Controlled Driving

A balanced combination of carbide ski runners and studs on the track ensures adequate control and better handling, see illustration.

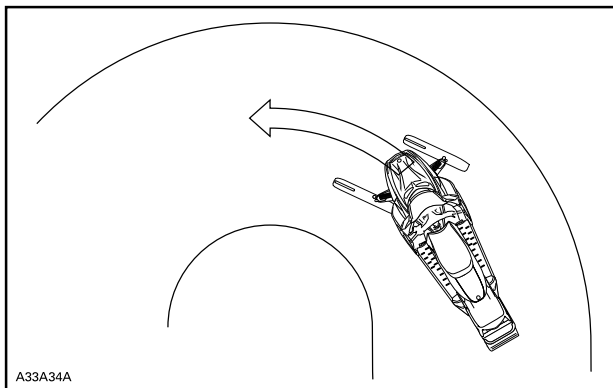

CONTROLLED DRIVING

Acceleration

Using studs on the track will allow your sled to accelerate better on packed snow and ice but will have no noticeable effect on soft snow. This can cause sudden variations in traction under certain conditions.

Always go easy on the throttle and never try to spin the track to make the rear of the snowmobile skid. This could cause debris or ice to be thrown violently backwards, possibly injuring others nearby or on snowmobiles behind you.

Braking

As in the case of acceleration, using studs on the track will give you better braking capacity on packed snow or ice but will have no noticeable effect on soft snow. Braking may thus vary suddenly under certain conditions. Be sure to use restraint in braking to keep from blocking the track in order to avoid surprises that could lead to a loss of control.

RIDE SAFELY

Rider Position (Forward Operation)

Your riding position and balance are the two basic principles of making your snowmobile go where you want it to. When turning on the side of a hill, you and your passenger must be ready to shift body weight to help it turn in the desired direction. Operator and passenger must never attempt this maneuvering by placing feet outside of the vehicle. Experience will teach you how much lean to put into turns at different speeds and how much you will have to lean into a slope to maintain proper balance.

Generally, the riding position for best balance and control is sitting. However, the posting, kneeling or standing positions are also used under certain conditions.

⚠ WARNING

Do not attempt any maneuvers if they are beyond your abilities.

Sitting

Feet on the running boards, body midway back on seat is an ideal position when operating the snowmobile over familiar, smooth terrain. Knees and hips should remain flexible to absorb shocks.



Posting

A semi-sitting position with the body off the seat and the feet under the body in a sort of squatting posture, thus allowing the legs to absorb the shocks when traveling over uneven terrain. Avoid abrupt stops.



Kneeling

This position is achieved by placing one foot firmly on the running board and the opposite knee on the seat. Avoid abrupt stops.



Standing

Place both feet on the running boards. Knees should be flexed to absorb the shock from surface bumps. This is an effective position to see better and to shift weight as conditions dictate. Avoid abrupt stop.



Rider Position (Reverse Operation)

When operating in reverse:

- Ensure the path behind is clear of obstacles or bystanders before proceeding in reverse.
- BRP recommends sitting on your snowmobile when operating in reverse.
- Avoid standing up. Your weight could shift forward against throttle lever while operating in reverse, causing an unexpected acceleration. Unexpected acceleration when snowmobile operates in reverse can cause a loss of control.

Fast reverse while turning, could result in loss of stability and control.

Riding with Passenger(s)

This vehicle is designed for one (1) operator and as many passengers as there are seats with straps or handholds installed on the vehicle conforming to SSCC standards. Passenger must only sit on designated passenger seat.

WARNING

- **Never carry a passenger on a seat not approved by BRP.**
- **Never allow anyone to sit between the handlebar and the operator.**

Even when a passenger is allowed, this person must be physically fit for snowmobiling.

Any passenger must always be able to firmly lay his feet on the footrests and keep his hands on the handholds or seat strap when seated. Respecting those physical criteria is important to ensure that the passenger is stable and to reduce the risks of ejection. Falls can result in severe injury or death.

The operator has a responsibility to ensure the safety of his passenger and should inform the passenger about snowmobiling basics.

Before riding the vehicle, adjust suspension according to weight. Refer to *Tune Your Ride* subsection for more details.

Ask your passenger to inform you to slowdown or stop immediately if he feels uncomfortable or insecure during the ride.

When going over bumps, riders(s) may raise their body slightly off the seat to absorb the shocks with their legs.

An unforeseen bump can leave you passenger-less. Remind your passenger to lean into the turn with you, without causing the vehicle to topple. Be extremely careful, go more slowly and check the passenger frequently. Keep a watchful eye on your passenger while riding.

Braking ability and steering control are reduced when riding with a passenger. Decrease speed and allow extra space to maneuver.

Riding Alone





Venturing out alone with your snowmobile could also be hazardous. You could run out of fuel, have an accident, or damage your snowmobile. Remember, your snowmobile is capable of traveling further in half an hour than you may be able to walk in a day. Use the "buddy system". Always ride with a friend or member of your snowmobile club. Even then, tell someone where you are going and the approximate time you plan to return.



Riding in a Group

Before starting out, designate a "trail boss" to lead the party and another person to follow-up at the end of the party. Ensure that all members of the party are aware of the proposed route and destination. When riding with others, limit your abilities to the experience of others. Never overtake the trail boss or, for that matter, any other snowmobile. Use down-the-line hand signals to indicate hazards or intent of direction change. It's important to keep a safe distance between each snowmobile but each one behind the leader should know the position of the machine ahead.

Hand Signals

Every snowmobiler should relay any signal to the ones behind.

<p>STOP Raise either hand straight above your head.</p> 	<p>LEFT TURN Extend your left hand straight out in the proper direction.</p> 
<p>RIGHT TURN Extend the left arm and raise the hand to a vertical position so it forms a right angle at the elbow.</p> 	<p>SLOWING DOWN Left hand extended out and down from the side of the body with downward flapping motion of hand to signal</p> 

	warning or caution.
<p>FOLLOWING SNOWMO BILES Arm raised, elbow bent with thumb pointing backward, in hitch-hicking motion move arm forward to backward over your shoulder.</p> 	<p>ONCOMING SNOWMO BILES Left arm raised at shoulder height, elbow bent and forearm vertical, wrist bent, move arm from left to right over head pointing to right side of trail.</p> 
<p>LAST SNOWMO BILE IN LINE Left arm raised at shoulder height, elbow bent and forearm vertical with hand clenched in a fist.</p> 	

Light Signals

As an alternative to the hand signals, a light signal system can be installed on your snowmobile. Whether it is an OEM or after-sales system, it consists basically in a 2 colors LED light that signals you are followed by other riders, or you are the last rider. It allows the rider to keep both hands on the handlebar for more safety while crossing other riders.

Visit you BRP snowmobile dealer for more information.

FOLLOWING SNOWMOBILES	YELLOW light
LAST SNOWMOBILE IN YOUR GROUP LINE	GREEN light

Avoiding Collisions

Wherever riding your vehicle always be on the look-out for the unexpected. Operate defensively. Scan constantly for people, objects, conditions and upcoming vehicles. In the trail, always stay on the appropriate side - as per country regulation - to avoid collision, especially when the field of vision is reduced. E.g.: Before a hilltop and a curve. Use extra caution whenever off-trail.

Always keep a safe distance from other snowmobiles and bystanders. Tailgating another snowmobile should be avoided. If the snowmobile in front of you slows for any reason, its operator and passenger could be harmed through your neglect. Maintain a safe stopping distance between you and the snowmobile in front of you. Depending on the terrain condition, stopping may require a little more space than you think. Play it safe. Be prepared to use evasive driving.

On land or water, fog or visibility-limiting snow can form. If you must proceed into the fog or heavy snow, do so slowly with your lights on and watch intently for hazards. If you are not sure of your way, do not proceed. Keep a safe distance behind other snowmobilers to improve visibility and reaction time.

Riding Behaviors

Injury or death may result to the snowmobile operator, passenger or bystander if the snowmobile is used in risky conditions which are beyond the operator's, passenger's or snowmobile's capabilities or intended use.

Remember, promotional material may show risky maneuvers performed by professional riders under ideal and controlled conditions. You should never attempt any such risky maneuvers if they are beyond your level of riding ability.

Jumping can be a hazardous situation. It requires practice and should be done in a known and controlled environment. Never attempt jumping in a trail. A loss of control could lead to an impact with different elements like rock or tree, or with another snowmobile. When jumping be prepared for landing to absorb the shock. Brace yourself for the impact and your knees must be flexed to act as shock absorbers.

Also, an uneven or mined surface in the trail could be enough to kick upward the snowmobile and generate an impact or a loss of control. When “gunning” the throttle, the vehicle digs into and leaves an irregular snow surface for others. So protect the other users by not spinning the track in the middle of the trail.

Speeding

Excessive speed and reckless driving can be fatal. Always adjust your speed according to snow conditions and circumstances. In many cases, you cannot react or respond quickly enough to the unexpected. Always ride at a speed which is suitable to the trail, weather conditions and your own ability. Know your local rules. Speed limit may be in effect and meant to be observed.

Moving Parts

Stay away from the track. Personal injury will result if contact is made with the rotating track.

To prevent serious injury to individuals near the snowmobile:

- Never stand behind or near a moving track
- Always use a wide-base snowmobile stand with a rear deflector panel if it is necessary to rotate track
- When the track is raised off the ground, only run it at the lowest possible speed. Centrifugal force could cause debris, damaged or loose studs, pieces of torn track, or an entire severed track to be violently thrown backwards out of the tunnel with tremendous force
- Never operate the engine without the belt guard securely installed
- Never operate the vehicle without the brake disk guard securely installed
- Never operate the vehicle with the side panels opened, or the hood removed

Know Terrain and Riding Variations

Groomed Trail

On a maintained trail, sitting is the most preferred riding position. Do not race and, above all, keep to the right hand side of the trail. Be prepared for the unexpected. Observe all trail signs. Do not zigzag from one side of the trail to the other.

Ungroomed Trail

Unless there has been a fresh snowfall you can expect “washboard” and snowdrift conditions. Taken at excessive speeds, such conditions can be physically harmful. Slow down. Hold on the handlebar and assume a posting position. Feet should be under the body assuming a crouched position to absorb any jarring effect. On longer stretches of

“washboard” trails, the kneeling position of one knee on the seat can be adopted. This provides a certain amount of comfort, while at the same time keeps the body loose and capable of vehicle control. Beware of hidden rocks or tree stumps partially hidden by a recent snowfall.

Deep Snow

In deep “powder” snow, your vehicle could begin to “bog” down. If this occurs, turn in as wide an arc as possible and look for a firmer base. If you do get “bogged”, and it happens to everyone, do not spin your track as this makes the vehicle sink deeper. Instead, turn the engine off, get off and move the back of the vehicle onto new snow. Then tramp a clear path ahead of the vehicle. A few feet will generally suffice. Restart the engine. Assume the standing position and rock the vehicle gently as you steadily and slowly apply the throttle. Depending on whether the front or rear end of the vehicle is sinking, your feet should be placed on the opposing end of the running boards. Never place foreign material beneath the track for support. Do not allow anyone to stand in front of, or to the rear of, the snowmobile with the engine running. Stay away from the track. Personal injury will result if contact is made with the revolving track.

Frozen Water

Traveling frozen lakes and rivers can be fatal. Avoid waterways. If you are in an unfamiliar area, ask the local authorities or residents about the ice condition, inlets, outlets, springs, fast moving currents or other hazards. Never attempt to operate your snowmobile on ice that may be too weak to support you and the vehicle. Operating a snowmobile on ice or icy surfaces can be very dangerous if you do not observe certain precautions. The very nature of ice is foreign to good control of a snowmobile or any vehicle. Traction for starting, turning or stopping is much less than that on snow. Thus, these distances can be multiplied manyfold. Steering is minimal, and uncontrolled spins are an ever present danger. When operating on ice, drive slowly with caution. Allow yourself plenty of room for stopping and turning.

Slush

Slush should be avoided at all times. Always check for slush before starting across any lake or river. If dark spots appear in your tracks, get off the ice immediately. Ice and water can be thrown rearward into the path of a following snowmobile. Getting a vehicle out of a slush area is strenuous and in some cases, impossible.

Uphill

There are two types of hills you can encounter — the open hill on which there are few trees, cliffs or other obstacles, and a hill that can only be climbed directly. On an open hill, the approach is to climb it by

side hilling or slaloming. Approach at an angle. Adopt a standing position with both feet on the same running board. Keep your weight on the uphill side at all times. Maintain a steady, safe speed. Continue as far as you can in this direction, then switch to an opposite hill angle and riding position.

A direct climb could present problems. Choose the standing position, accelerate before you start the climb and then reduce throttle pressure to prevent track slippage.

In either case, vehicle speed should be as fast as the incline demands. Always slow down as you reach the crest. If you cannot proceed further, don't spin your track. Apply the parking brake, turn the engine off, free the skis by pulling them out and downhill, place the rear of the snowmobile uphill, restart the engine, release the parking brake and ease it out with slow even throttle pressure. Position yourself to avoid tipping over, then descend.

Downhill

Downhill driving requires that you have full control of your vehicle at all times. On steeper hills, keep your center of gravity low and both hands on the handlebar. Maintain slight throttle pressure and allow the machine to run downhill with the engine operating. If a higher than safe speed is reached, slow down by braking but apply the brake with frequent light pressure. Never jam the brake and lock the track.

Side Hill

When crossing a side hill or traversing up or downhill, certain procedures must be followed. All riders should lean towards the slope as required for stability. The preferred operating positions are the standing position, with both feet on the running board that is facing uphill. Be prepared to shift your weight quickly as needed. Side hills and steep slopes are not recommended for a beginner or a novice snowmobiler.

Avalanche Hazard

When riding on mountainous terrain, you should be aware of the risk of avalanches. Avalanches vary in size and shapes and generally occur in steep terrain and on unstable snow.

New snow, animals, people, wind and snowmobiles can all trigger an avalanche. Avoid high marking or traversing steep terrain when avalanche conditions are possible. When in unstable snow conditions, travel should be restricted to lower angle slopes. Wind formed cornices should be avoided. Staying off unstable conditions is the key to safe mountain riding. Probably most important is to be aware of the conditions and dangers on a daily basis when in the mountains. Check local avalanche forecasts and threats each day before heading out to ride and heed forecasters advice.

You should always carry a snow shovel, probe and avalanche beacon while riding on mountains.

Bright Sunshine

Bright sunny days can considerably reduce your vision. The glare from sun and snow may blind you to the extent that you cannot easily distinguish ravines, ditches or other obstacles. Goggles with colored lenses should always be worn under these conditions.

Night Rides

The amount of natural and artificial light at a given time can affect your ability to see or to be seen. Be extra cautious. Drive at speeds that will allow you to stop in time when you see an unknown or dangerous object ahead. Stay on established trails and never operate in unfamiliar territory. Be sure both headlights and taillight are working and clean.

Unfamiliar Territory

Whenever you enter an area that is new to you, drive with extreme caution. There may be obstructions hidden beneath the snow. Go slow enough to recognize potential hazards such as fences or fence posts, brooks crossing your path, rocks, sudden dips, guy wires and countless other obstacles which could result in a termination of your snowmobile ride.

Driving off established trails and in the woods requires reduced speed and increased vigilance. Driving too fast in an area can make even minor obstacles very hazardous. Even hitting a small rock or stump could throw your snowmobile out of control and cause injury to its riders. Even when following existing tracks, be cautious. Travel at a speed so you can see what is around the next bend or over the top of the hill.

Hidden Wires

Always be on the lookout for hidden wires, especially in areas that may have been farmed at one time or another. Too many accidents have been caused by running into wires in the fields, guy wires next to poles and roads, and into chains and wires used as road closures. Slow speeds are a must.

Riding Uneven Surfaces

Unplanned jumps of snowdrifts, snowplow ridges, culverts, indistinguishable objects or sudden drop in the trail can be dangerous. You can avoid them by wearing the proper color lenses or face shields and by operating at a lower speed.

A good way to help seeing these terrain variations is to wear the proper color lenses or face shields and by operating at a lower speed. Crouch (stand) towards the rear of the vehicle and keep the skis up

and straight ahead. Apply partial throttle and brace yourself for the impact. Knees must be flexed to act as shock absorbers.

Road Crossing

Your snowmobile is not designed to operate or turn on pavement of public streets, roads or highways. Avoid road traveling. If you must do so, and it is permitted, reduce speed and stay on the edge of the way where you can find snow to help providing capabilities to maintain directional control.

As snowmobile trails often cross roadways it is important for riders to know the proper crossing procedures. When approaching a roadway, signal to others that you are stopping at the intersection and slowly come to a complete stop back from the road's edge. In some cases, you will be approaching the road from a ditch or snowbank. Choose a place where you know you can climb without difficulty. Stop completely at the top of the bank and wait for all traffic to clear. Then, look carefully in both directions before crossing at a 90° angle. If needed, assume a standing position to look both ways. Be wary of parked vehicles. When you are certain that the road is clear proceed straight across the intersection without hesitation. Each rider needs to come to a complete stop, look both ways and then proceed when the roadway is clear of oncoming traffic.

Railroad Crossing

Never ride on railroad tracks. It is illegal. Railroad tracks and railroad rights-of-way are private property. A snowmobile is no match for a train. Before crossing a railroad track, stop, look and listen.

Respect of the Wildlife

Wildlife compliments your snowmobiling day. Snowmobile tracks provide firm ground over which animals can travel from area to area. Do not violate this privilege by chasing or harassing wildlife. Fatigue and exhaustion can lead to animal's death. Avoid areas posted for the protection or feeding of wildlife. If you happen to be fortunate enough to see an animal, stop your snowmobile and observe quietly.

Carbon Monoxide (CO) Poisoning

All engine exhaust contains carbon monoxide (CO), a deadly gas. Breathing carbon monoxide can cause headaches, dizziness, drowsiness, nausea, confusion and eventually death.

Carbon monoxide is a colorless, odorless, tasteless gas that may be present even if you do not see or smell any engine exhaust. Deadly levels of carbon monoxide can collect rapidly, and you can quickly be overcome and unable to save yourself. Also, deadly levels of carbon

monoxide can linger for hours or days in enclosed or poorly ventilated areas.

If you experience any symptoms of carbon monoxide poisoning, leave the area immediately, get fresh air and seek medical treatment.

To prevent serious injury or death from carbon monoxide:

- Never run the vehicle in poorly ventilated or partially enclosed areas such as garages, carports or barns. Even if you try to ventilate engine exhaust with fans or open windows and doors, carbon monoxide can rapidly reach dangerous levels.
- Never run the vehicle outdoors where engine exhaust can be drawn into a building through openings such as windows and doors.
- Never stand next to the vehicle while the engine is running. A person standing next to the vehicle when the engine is running may inhale high concentrations of exhaust fumes.

After riding, always remove the tether cord from the engine cut-off switch to avoid unauthorized use by children or others and to prevent starting in a closed environment (ex: garage).

Gasoline Fires and Other Hazards

Gasoline is extremely flammable and highly explosive. Fuel vapors can spread and be ignited by a spark or flame many feet away from the engine. To reduce the risk of fire or explosion, follow these instructions:

- Use only an approved gasoline container to store fuel.
- Strictly adhere to instructions in *Vehicle Fueling Procedure*.
- Never start or operate the engine if the fuel cap is not properly installed.
- Use only a BRP approved LinQ fuel caddy to carry extra fuel on the vehicle. It should be properly installed and secured.

Gasoline is poisonous and can cause injury or death.

- Never siphon gasoline by mouth.
- If you swallow gasoline, get any in your eye or inhale gasoline vapor, visit your doctor immediately.
- If gasoline spills on you, wash with soap and water and change your clothes.

Burns from Hot Parts

Certain components may become hot during operation. Avoid contact during and shortly after operation to avoid burns.

PRACTICE EXERCISES

Practice alone the following exercises after having done the entire Pre-ride inspection. Always start and stop the engine according to the instructions in *ENGINE STARTING PROCEDURE* and *SHUTTING OFF THE ENGINE* in *BASIC PROCEDURES*. Don't forget to attach the tether cord to your jacket.

Where to Practice Exercises

Find a suitable area to practice the exercises. Ensure the area meet the following requirements:

- No traffic
- No obstacles
- Hard packed snow
- Ample space to maneuver.

Exercises to Practice

Practice alone the following exercises after having done the entire Pre-ride inspection. Always start and stop the engine according to the instructions in *ENGINE STARTING PROCEDURE* and *SHUTTING OFF THE ENGINE* in *BASIC PROCEDURES*. Don't forget to attach the tether cord to your jacket.

Using the Emergency Engine Stop Switch

Purpose: Become familiar with the operation of throttle lever and to become familiar with using the engine stop switch.

Directions:

- With the parking brake engaged, start the engine and let idle until it reaches the operation temperature.
- Use the engine stop switch to shut the engine off. Press the switch with your right thumb while keeping your hand on the handgrip.
- Restart the engine and repeat the exercise. No idle time is required.

Tips for additional practice:

- Press the emergency engine stop switch without looking at it.

Starting, Stopping and Basic Handling

Purpose:

- Learn throttle control and how to get the vehicle moving.
- Become familiar with low speed deceleration and braking.

If you feel like you are losing control while doing this exercise, release the throttle to stop accelerating and apply the brake as needed to slow down. You can also use the engine stop switch to cut power entirely.

Directions: At first, you will only use the throttle for a moment at a time, then release it and coast.

- Start the engine and release the parking brake lever.
- Slowly apply throttle until the vehicle starts to creep forward. As soon as you start moving release the throttle and coast, then press the brake lever to stop.
- Continue with this part of the exercise until you are comfortable with applying and releasing the throttle.

Engine Stop While in Motion

Purpose: Become familiar with using the emergency engine stop switch when in motion so you know how the vehicle will react if you need to use it later.

Directions:

- Partway down the straightaway, while operating at 8 km/h (5MPH), toggle the engine stop switch to OFF position and coast to a stop.
- Restart the engine and repeat the exercise. Try increasing your speed (to a maximum of 20 km/h (12MPH) before using the engine stop switch.

In an emergency, the snowmobile engine can be stopped by pressing down on the emergency engine stop switch or by pulling the tether cord cap from the engine cut-off switch, while applying brake.

Basic Turns

Purpose: Get comfortable turning in a controlled manner on both sides.

Directions:

- Roll in a straight line at low speed and make a wide arcing turn. Make sure there is enough space to perform the entire turn.
- Repeat right and left turns and maintain a steady speed below 8km/h (5MPH). Hold the throttle to maintain your low speed.
- Leaning forward and into the curve may help you to turn the handlebar more easily.

Quick Stops

Purpose:

- Become familiar with the vehicle braking ability.
- Learn to apply brakes with maximum efficiency.

This exercise is like what you did before, except you'll be applying the brake more firmly, working up to braking at the maximum without locking the track rotation. Always release the throttle completely for quick stops. If you apply throttle and brake at the same time, your stopping distance will be longer.

Directions:

- Start at one end of the straightaway and accelerate to 8 km/h (5MPH). Partway down the straightaway, release the throttle completely and brake quickly.
- Keep head and eyes up, keep handlebar straight, and do not release the brake until fully stopped.
- Repeat, increasing your speed and braking harder. When you feel that the rotation of the track will be stopped you need to release the pressure on the break lever. To maintain control, you need to keep the track in rotation.

Operating in Reverse

Purpose: Become familiar with the vehicle handling and turning radius in reverse.

Directions:

- Shift into reverse and remain seated. Refer to *SHIFTING IN REVERSE* in *BASIC PROCEDURES*.
- Check that the area behind you is clear. While looking backwards, slowly reverse and stop by releasing throttle and using the brake, just like when operating normally.
- Keep your speed low and do not back up for long distances.
- Repeat the reverse and stop in straight line until you get comfortable.
- Once you are comfortable with reversing in straight line, you can slowly reverse while turning the handle bar.

FUELING

Fuel is flammable and explosive under certain conditions.

- Never use an open flame to check fuel level.
- Never smoke or allow flame or spark in vicinity.
- Always proceed in a well-ventilated area.

Fueling Procedure

1. Stop engine and engage the parking brake.
2. Have operator and passenger get off the vehicle. Do not sit or lean on seat when fuel tank cap is not properly installed.
3. Unscrew slowly the fuel reservoir cap counterclockwise to stabilize pressure before removing it.

NOTE:

A short whistling sound is normal.

4. Insert the spout into the filler neck.
5. Pour fuel slowly so that air can escape from the tank and prevent fuel flow back. Be careful not to spill fuel.
6. Stop filling after the release of the gas pump nozzle handle and wait a moment before removing the spout. Do not retract the gas pump nozzle to put more fuel into the fuel tank. **Do not overfill.**
7. Reinstall the fuel cap and fully tighten clockwise.
8. Always wipe off any small fuel spillage from the vehicle. If a major spillage occurs, remove side panels to remove fuel vapors from engine compartment before starting.
9. Before getting on the way don't forget to disengage the parking brake.
10. Never top up the fuel tank before placing the vehicle in a warm area. As temperature increases, fuel expands and may overflow.

TRANSPORTING THE VEHICLE

Make sure that oil reservoir and fuel tank caps are properly installed.

Many type of trailer can be used to transport a vehicle. Tilt-bed, flatbed or enclosed trailers, no matter the trailer used, always proceed with precaution when driving the vehicle on and off of it.

Always anchor the vehicle securely, front and rear, even on short hauls. Use appropriate tie-down straps only. Make sure all equipment is securely fastened. Cover the vehicle to prevent road grime from causing damage.

Make sure the trailer meets state or provincial requirements. Ensure the hitch and safety chains are secured, and the brake, turn indicators and clearance lights are functional.

 **WARNING**

Make sure all seats, accessories and cargo are properly secured, or remove it to prevent from falling on the road and creating a hazard for following vehicles.

 **WARNING**

Do not tow the vehicle facing backwards. If the vehicle is towed facing backwards, the wind may cause damage to the windshield or even loss of the windshield.

IMPORTANT ON-PRODUCT LABELS

Vehicle Safety Labels

These labels are affixed to the vehicle for the safety of the operator, passenger or bystanders.

The following labels are on your vehicle and they should be considered permanent parts of the vehicle. If missing or damaged, the decals can be replaced free of charge. Visit an authorized BRP snowmobile dealer.

NOTE:

In the event of any discrepancy between this guide and the vehicle, the safety labels on the vehicle have precedence over the labels in this guide.

Rotating Parts — Warning Label



ROTATING PARTS — WARNING LABEL

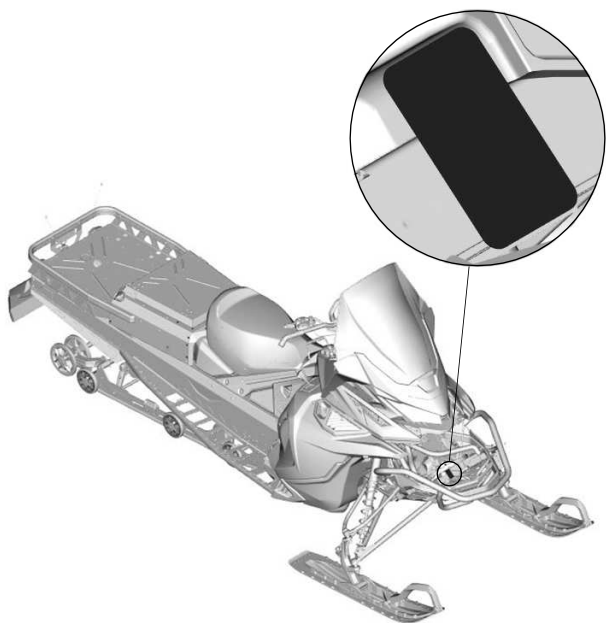

Shock Absorber - Warning Label



WARNING

- This shock absorber is pressurized.
- An explosion may occur if heated or punctured.
- Do not disassemble.

SHOCK ABSORBERS - WARNING LABEL

Pulley Guard and Drive Pulley Tightening Torque - Warning and Notice Label

⚠ WARNING

This guard must ALWAYS be in place when engine is running. Beware of rotating parts, they could cause injuries or catch your clothing.

NOTICE

- Drive pulley bolt recommended torque is 115 to 125 Nm (85 to 92 lbf-ft).
- Not applying the recommended torque may result in a major failure of the drive pulley and the engine.
- Refer to the shop manual for the complete assembly procedure.



PULLEY GUARD AND DRIVE PULLEY TIGHTENING TORQUE - WARNING AND NOTICE LABEL

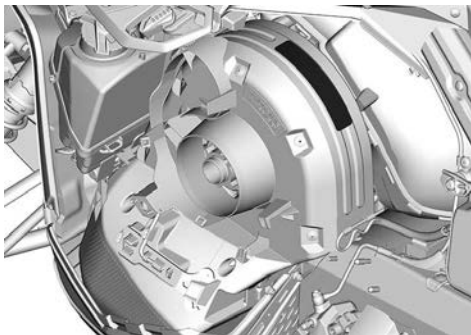

Do Not Open When Hot - Warning Label



DO NOT OPEN WHEN HOT - WARNING LABEL

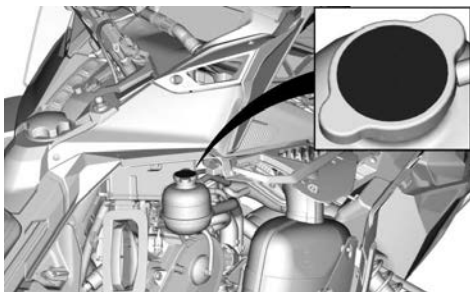

Do Not Open When Hot - Warning Label

! WARNING

Do not open when hot.



DO NOT OPEN WHEN HOT- WARNING LABEL

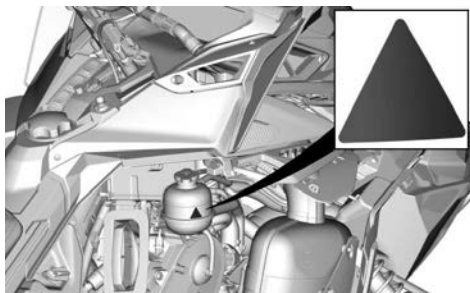

Beware of Hot Parts - Caution Label



BEWARE OF HOT PARTS— CAUTION LABEL

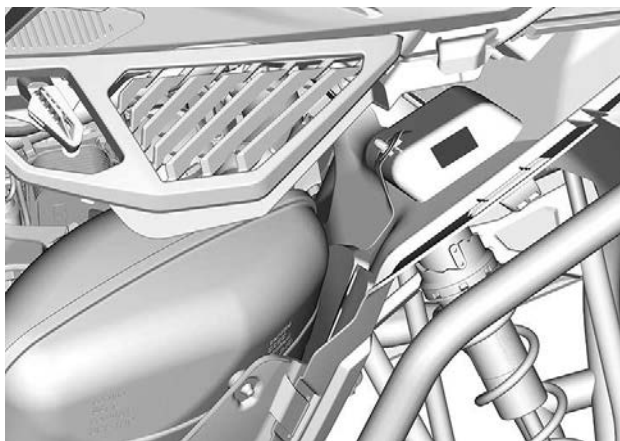

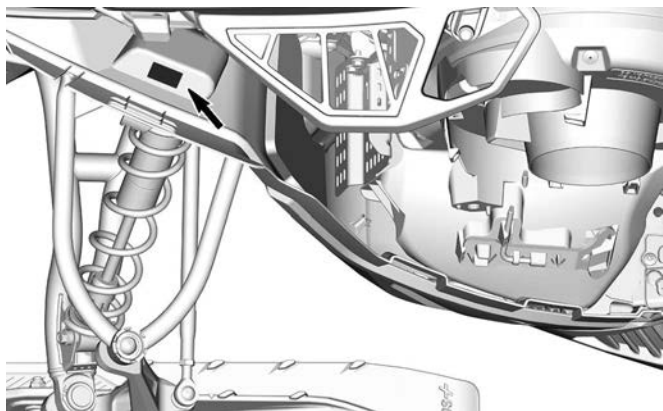

Engine Oil Level - Caution Label

 **CAUTION**

Engine oil and Certain components in the engine compartment may be hot. Direct contact may result in skin burn.
Checking the engine oil:

1. Make sure the engine is at operating temperature.
2. Vehicle must be level to perform verification.
3. Let the engine run at idle for at least 30 seconds.
4. Stop the engine and wait 30 seconds.
5. Check the oil level using the dipstick.

The engine of this snowmobile has been developed and validated using the BRP XPS™ Synthetic 4-stroke oil.

BRP Recommends the use of its XPS approved lubricant or equivalent.

Damages caused by oil which is not suitable for this engine may not be covered by BRP limited warranty.

Refer to the operator's guide for more information.

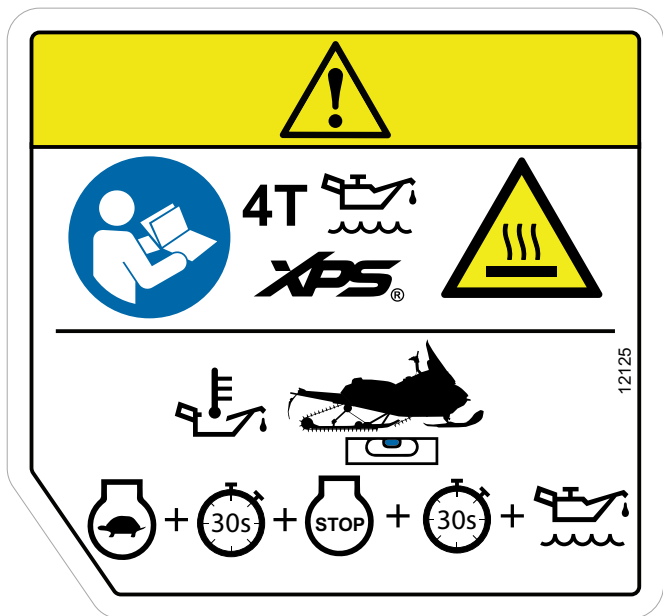

ENGINE OIL LEVEL – CAUTION LABEL



INSIDE THE LH SIDE PANEL

Disk Guard - Warning Label

 **WARNING**

This guard must ALWAYS be in place when engine is running.

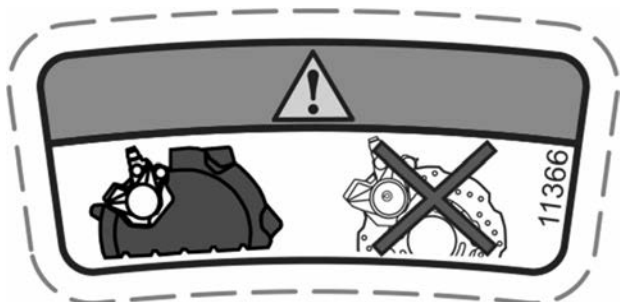

DISK GUARD - WARNING LABEL

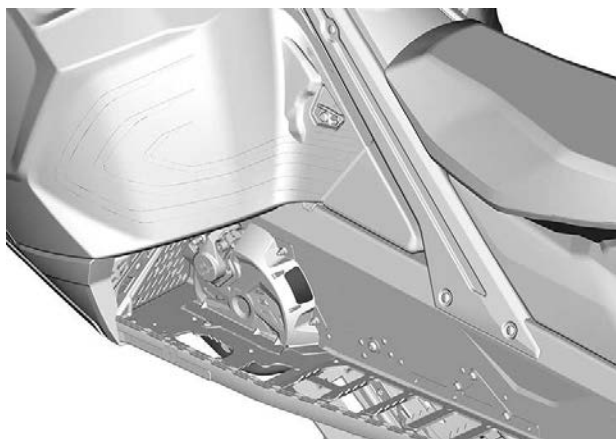

Correct Towing Direction - Warning Label

! WARNING

- ALWAYS tow this vehicle facing forward.
- NEVER tow this vehicle facing backward. Windshield could detach and become a road hazard.

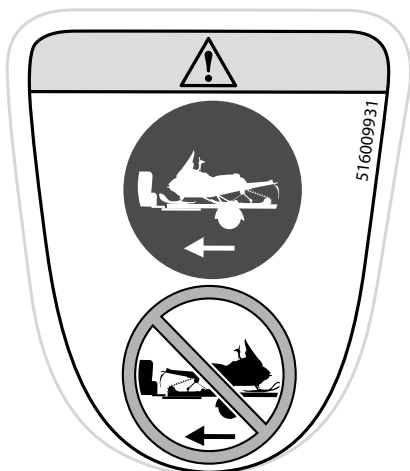

CORRECT TOWING DIRECTION - WARNING LABEL



Starting Procedure - Warning Label**⚠ WARNING**

- Read and understand all safety labels, locate and read operator's guide and watch the safety video (using the QR code link or visit Ski-Doo web site) before operation.
- Get familiar with your vehicle. Inexperienced riders may overlook risks and be surprised by vehicle's specific behavior and terrain conditions. Ride slowly.
- Excessive speed and reckless driving can kill.
- ALWAYS adjust your speed according to snow conditions and circumstances.
- Steering control and braking ability may be reduced on hard-pack snow, ice or roads. Reduce speed & allow more space to stop or turn.
- Respect laws on minimum operator age. Manufacturer recommends a minimum operating age of 16 years old.
- Never open side panels or hood while engine is running or if vehicle is in motion. Ensure to remove tether cord from post before opening those.

Before Starting:

Attach tether cord to your clothing. Check proper operation of the throttle and brake levers each time before starting; they must return to their initial position when released. Apply parking brake. Turn handlebars all the way in both directions to check for interference and insure free operation.

After Starting:

Pull-out tether cord to check if engine shuts off. Re-start and push in the emergency engine stop switch to check if engine shuts off. Disengage parking brake before riding to avoid brake fading.

When riding with a passenger:

- Braking ability and steering control are reduced.
- Decrease speed and allow extra space to manoeuvre.
- Adjust suspension according to weight.

Remember: you are responsible for the safety of your passenger. All drivers and passengers must read the following:

- Avoid surprises, be on the look out for the unexpected.
- Operate defensively, scan constantly for people, objects, conditions and upcoming vehicles.
- Avoid thin ice / open water.
- Use extra caution whenever off-trail.
- Always wear an approved helmet and clothing appropriate for snowmobiling.
- Never ride under the influence of alcohol or drugs, even as a passenger.

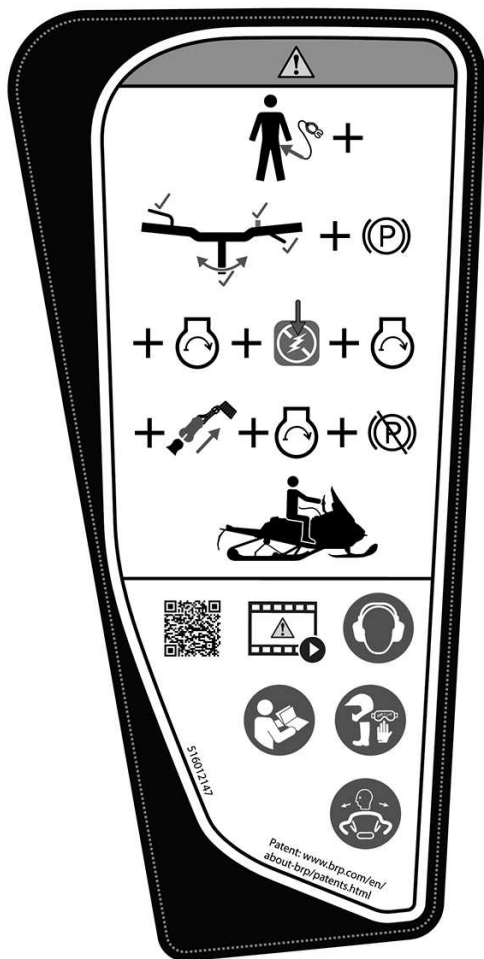

STARTING PROCEDURE - WARNING LABEL



LABEL LOCATION

Passenger Safety - Warning Label

⚠ WARNING

Remember: you are responsible of the safety of your passenger.

All drivers and passengers must read the following:

- 16 years old is the minimum age required to drive this vehicle.
- Use extra caution whenever off-trail.
- Avoid thin ice/ open water.
- Never ride under the influence of alcohol or drugs, even as passenger.

When riding with a passenger:

- Braking ability and steering control are reduced.
- Decrease speed and allow extra space to maneuver.
- Adjust suspension according to weight.

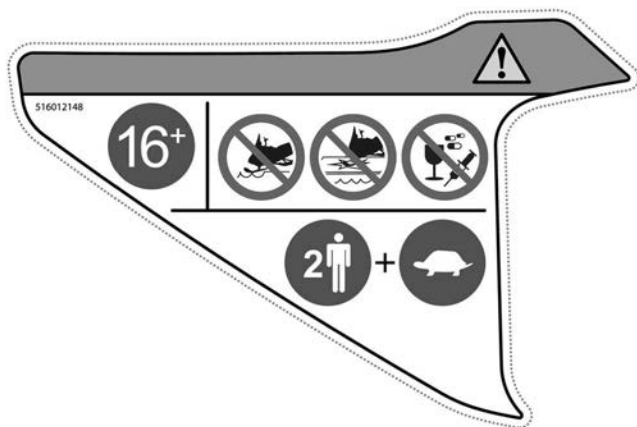

PASSENGER SAFETY - WARNING LABEL

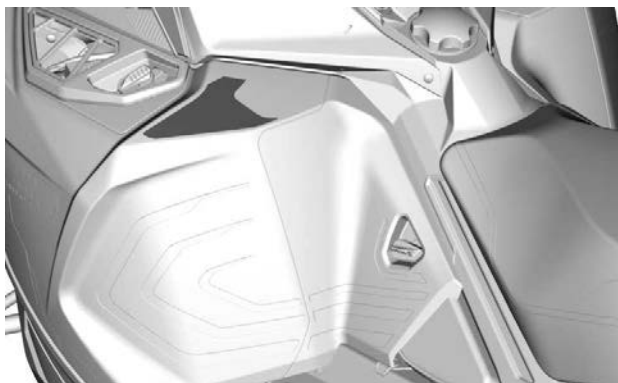

LABEL LOCATION

Passenger Safety - Warning Label

! WARNING

This vehicle is design for one (1) operator and as many passengers as there are seats with straps or handgrips installed on the vehicle conforming to SSCC standards.

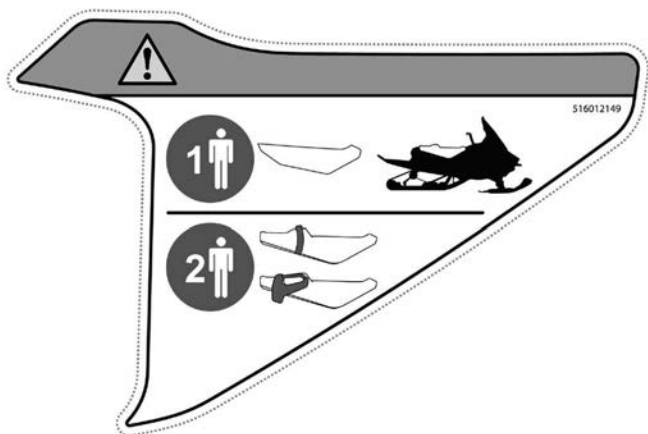

PASSENGER SAFETY - WARNING LABEL



LABEL LOCATION

400 mm (16 in.) Tunnel Width

Passenger Backrest and Handles - Warning Label

⚠ WARNING

- Refer to the operator's guide for more details.
- Make sure the passenger handles are correctly locked in place.



PASSENGER HANDLES— WARNING LABEL

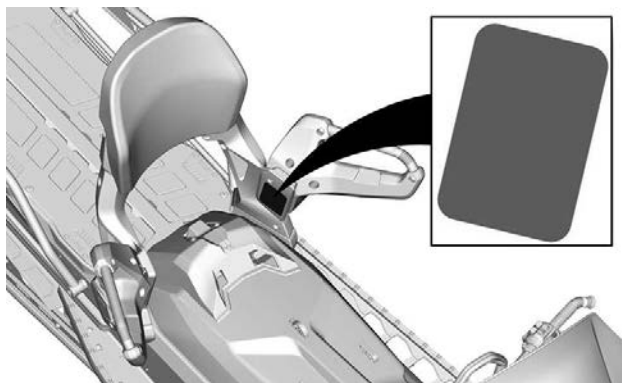

Maximum Cargo Load and Towing Capacity - Warning Label

WARNING

- Always use a securely fastened rigid tow bar to tow.
- Refer to the operator's guide for more details.
- Exceeding maximum cargo may affect steering control, braking ability and cause permanent damage.
- **MAXIMUM** cargo load (including tongue weight): 25 kg (245 N)
- **MAXIMUM** tongue weight: 10 kg (98 N)
- **MAXIMUM** towing capacity: 250 kg (2453 N)

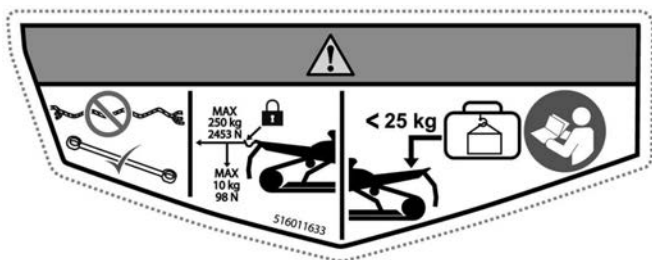

CARGO AREA – WARNING LABEL

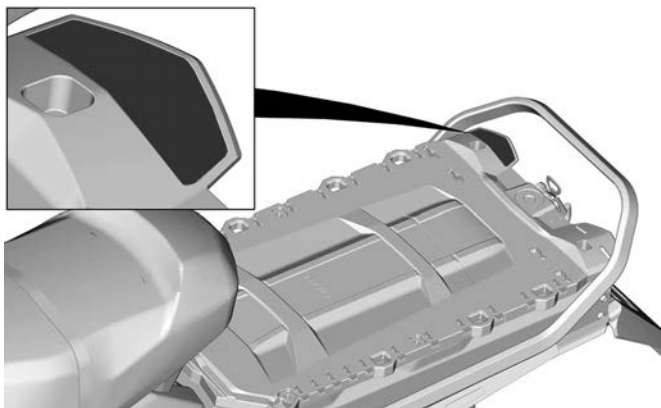

TYPICAL

Rotating Track — Warning Label

 **WARNING**

- NEVER stand behind or near a rotating track. Debris could be projected causing severe injuries.
- NEVER sit in cargo area.



ROTATING TRACK — WARNING LABEL

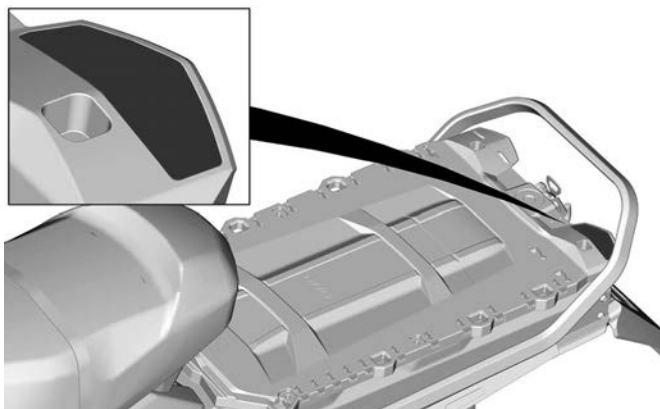

TYPICAL

500 and 600 mm (20 and 24 in.) Tunnel Width

Passenger Seat - Warning Label

 **WARNING**

BEFORE riding, ALWAYS make sure that the latch on each side of the seat or the accessory is fully engaged.

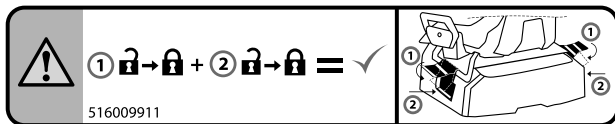

PASSENGER SEAT - WARNING LABEL

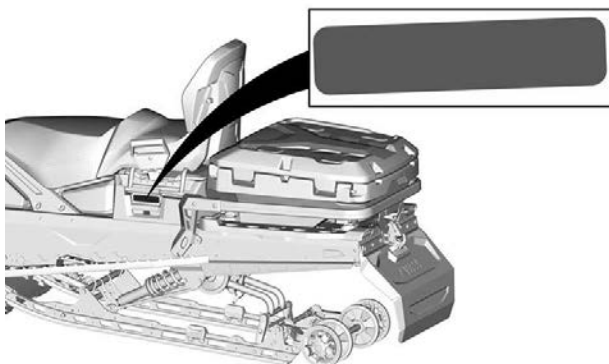

Molded Safety Pictogram

 **WARNING**

Never carry passengers on the rear storage compartment.

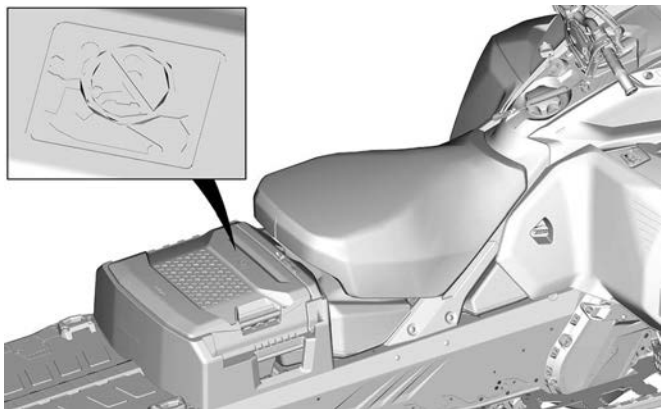
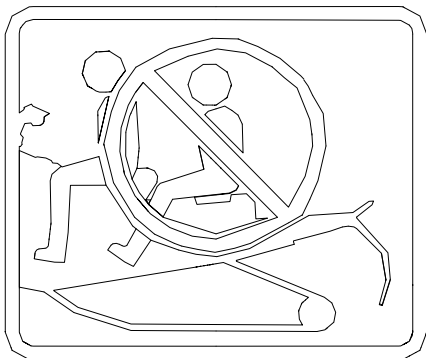

Rear Storage Compartment - Warning Label

WARNING

To reduce the risk of severe injury or death:

- Never carry flammable or dangerous liquids inside cargo box. If ignited, this can lead to an explosion.
- Make sure the cover is closed and latched before riding.

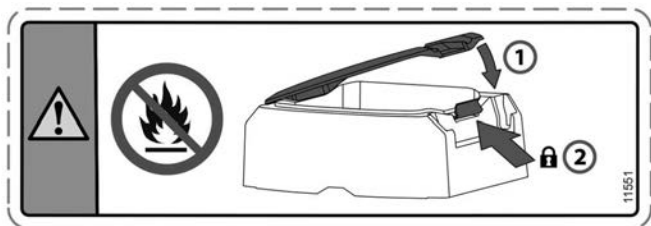

REAR STORAGE COMPARTMENT - WARNING LABEL

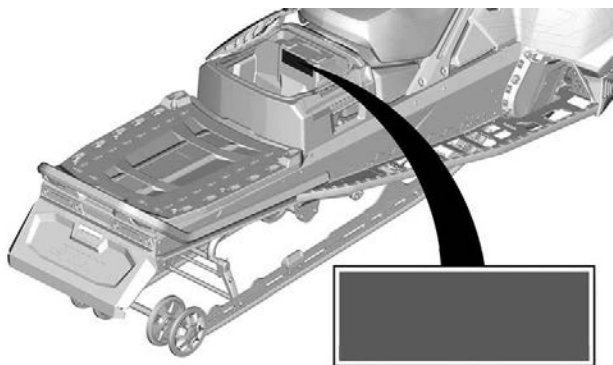

TYPICAL

Maximum Towing Capacity - Warning Label

⚠ WARNING

- Always use a securely fastened rigid tow bar to tow.
- Refer to the operator's guide for more details.
- Exceeding maximum cargo may affect steering control, braking ability and cause permanent damage.
- **MAXIMUM** cargo load: 57 kg (559 N)
- **MAXIMUM** tongue weight: 10 kg (98 N)
- **MAXIMUM** towing capacity: 544 kg (5338 N)

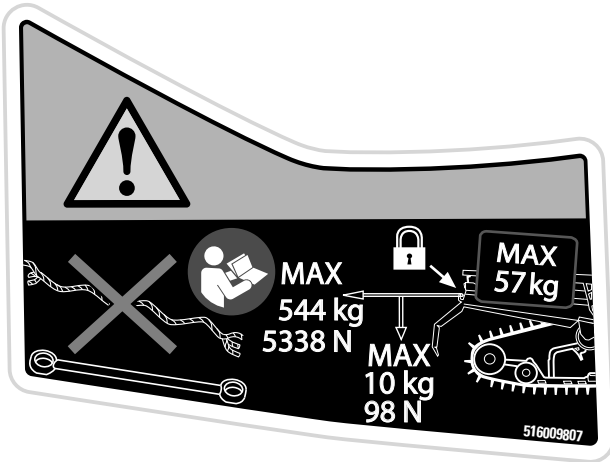

MAXIMUM CARGO LOAD AND TOWING CAPACITY - WARNING LABEL

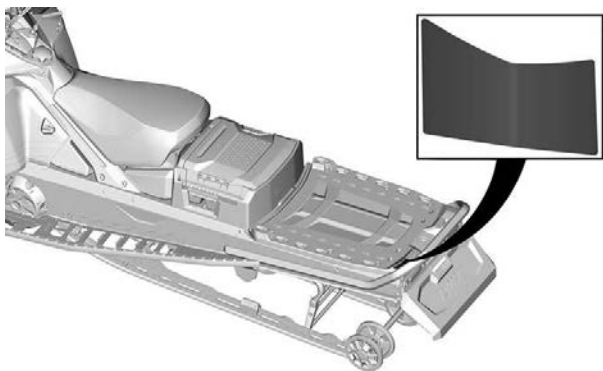

LABEL LOCATION — TYPICAL

Rotating Track - Warning Label

⚠ WARNING

- NEVER stand behind or near a rotating track. Debris could be projected causing severe injuries. To remove packed snow/ice, stop engine, lift and hold vehicle on the side and use wrench tool on the belt guard.
- NEVER sit in cargo area.

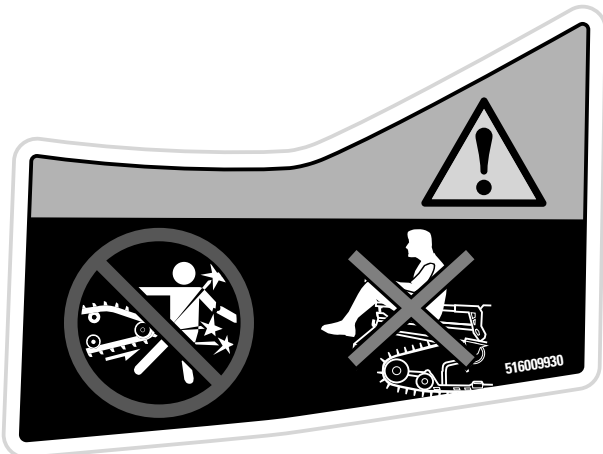

PROHIBITIONS - WARNING LABEL

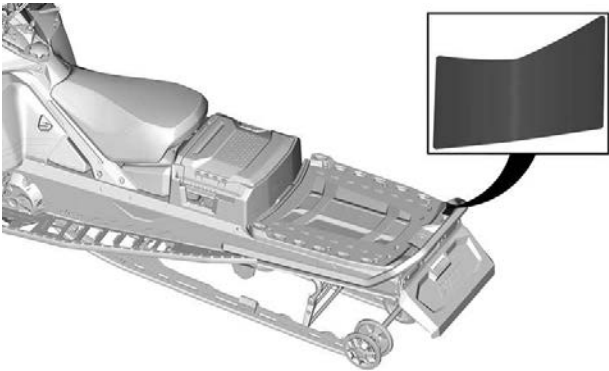

LABEL LOCATION — TYPICAL

Rear Cargo Box - Warning Label

WARNING

- Exceeding maximum cargo load may affect steering control, braking ability and cause permanent damage.
- For maximum cargo load specification, refer to the operator's guide.
- Maximum cargo load capacity of cargo box lid: 20 kg (44 lb).
- Maximum cargo load capacity of the box, including inside and on lid: 48 kg (105 lb).



REAR CARGO BOX (OUTSIDE) – WARNING LABEL

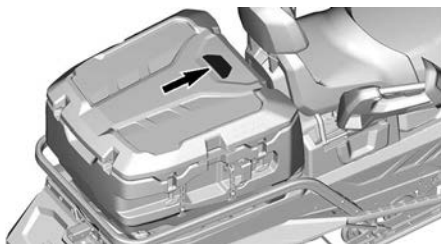

LABEL LOCATION

Rear Cargo Box - Warning Label

 **WARNING**

- NEVER carry a child or pet in this cargo box. The cargo box is airtight which can lead to suffocation.
- NEVER carry flammable or dangerous liquid inside the cargo box. If ignited, this can lead to an explosion and cause severe injury or death.
- For maximum cargo load specification, refer to the operator's guide.
- Maximum cargo load capacity of cargo box lid: 20 kg (44 lb).
- Maximum cargo load capacity of the box, including inside and on lid: 48 kg (105 lb).

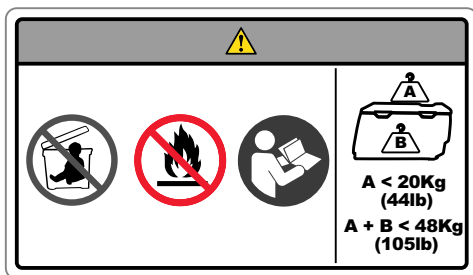
**REAR CARGO BOX (INSIDE) – WARNING LABEL****LABEL LOCATION**

Technical Information Labels

Adjustment Tools Label

- Install suspension adjustment tool first. (Illustrated red on label)
- Install pulley expander and Headlight adjustment tool second. (Illustrated blue on label)
- Refer to *Tools in Equipment*.

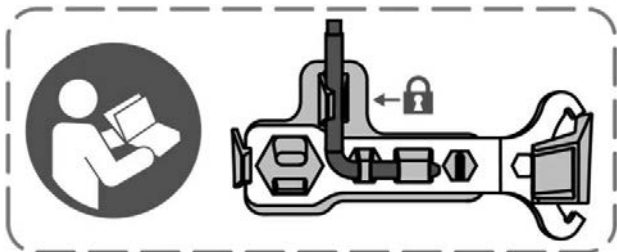

ADJUSTMENT TOOLS

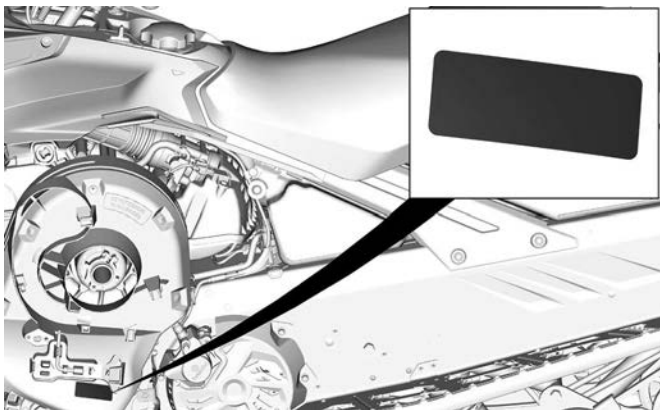

TYPICAL

Recommended Fuel — Notice Label

Refer to the *Technical Specifications* for appropriate fuel type for your vehicle engine.



AKI (RON+MON)/2 OCTANE RATING - NOTICE LABEL



RON OCTANE RATING - NOTICE LABEL

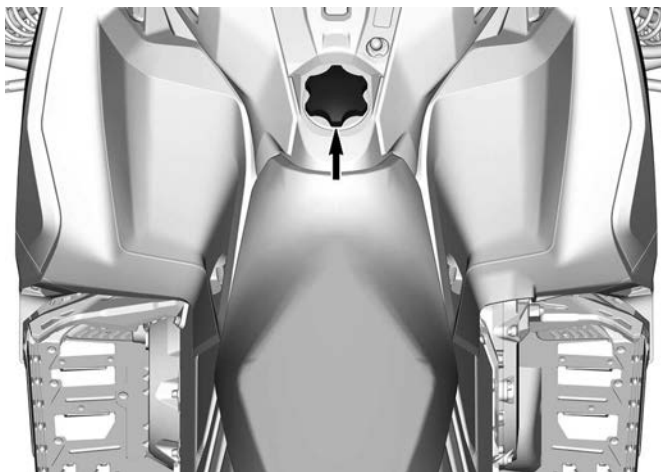

PRE-RIDE INSPECTION

Perform a pre-ride inspection before each ride to detect potential problems during operation. The pre-ride inspection can help you monitor wear and deterioration before they become a problem. Correct any problems that you discover to reduce the risk of an accident or a malfunction.

Before Starting the Engine

1. Remove snow and ice from body including lights, seat, footrests, controls and instruments.
2. Remove packed snow and ice from the rear suspension using the wrench tool stored on the drive belt guard.
3. Verify that air silencer prefilter is free of snow.
4. Verify that skis and steering operate freely. Check corresponding action of skis versus handlebar.
5. Check fuel and injection oil for levels and leaks. Replenish if necessary and in case of any leaks; you should seek service from an authorized BRP snowmobile dealer, repair shop, or person of your own choosing for maintenance, repair, or replacement.
6. All storage compartments must be properly latched and they must not contain any heavy or breakable objects. Hood and side panels must be also properly latched.
7. Activate the throttle control lever several times to check that it operates easily and smoothly. It must return to idle position when released.
8. Activate the brake lever and make sure the brake fully applies before the brake control lever touches the handlebar grip. It must fully return when released.
9. Apply parking brake and check if it operates properly. Leave parking brake applied.
10. Inspect drive belt condition and height. Refer to *drive belt* in *maintenance procedures*.

After Engine is Started

For proper engine starting procedure, refer to the appropriate *Engine Starting Procedure*.

1. Check headlights high beam and low beam, taillight, stop light and pilot lamps operation.

NOTE:

You may need to detach tether cord from your clothes to check lights. In such a case, attach cord as soon as you get back at the controls of the snowmobile.

2. Check the engine cut-off switch (by pulling tether cord cap) and emergency engine stop switch operation.
3. Release parking brake.
4. Refer to *Vehicle warm up* and follow instructions.

Pre-Ride Check List

ITEM	OPERATION	✓
BODY INCLUDING SEAT, FOOTRESTS, LIGHTS, AIR FILTER, CONTROLS AND INSTRUMENTS	Check condition wear and remove snow or ice .	
SKIS AND STEERING ACTION	Check for free movement and proper operation.	
SKI RUNNERS	Check for proper operation and abnormal wear.	
FUEL	Check for proper level and no leaks.	
INJECTION OIL (IF APPLICABLE)	Check for proper level and no leaks.	
COOLANT	Check for proper level and no leaks.	
DRIVE BELT	Check for cracks, fraying or abnormal wear and proper height.	
THROTTLE LEVER	Check for proper operation.	
BRAKE LEVER	Check for proper operation.	
PARKING BRAKE, BRAKE	Check for proper operation.	
BRAKE FLUID	Check for proper level and no leaks.	
STORAGE COMPARTMENT	Check for proper latching and no heavy or breakable objects.	
TRACK	Check condition and remove snow or ice. For studded tracks, refer to <i>Traction Enhancing Products</i> .	
SLIDER SHOES	Check for proper operation and abnormal wear.	

EMERGENCY ENGINE STOP SWITCH AND ENGINE CUT-OFF SWITCH (TETHER CORD CAP)	Check for proper action. Tether cord must be attached to operator clothing eyelet.	
LIGHTS	Check for proper operation.	
HORN BUTTON (IF EQUIPPED)	Check for proper operation.	

This page is intentionally blank

VEHICLE INFORMATION

PRIMARY CONTROLS

Handlebar

The handlebar controls the steering of the snowmobile. As the handlebar is rotated to right or left, the skis are turned right or left to steer the snowmobile.

⚠ WARNING

Fast reverse while turning, could result in loss of stability and control.



TYPICAL

Throttle Lever

Throttle lever is located on the RH side of handlebar.

When squeezed, it increases the engine speed. When released, engine speed returns automatically to idle.

Models with 900 ACE Turbo or 900 ACE Turbo R Engine

Designed to be thumb activated.

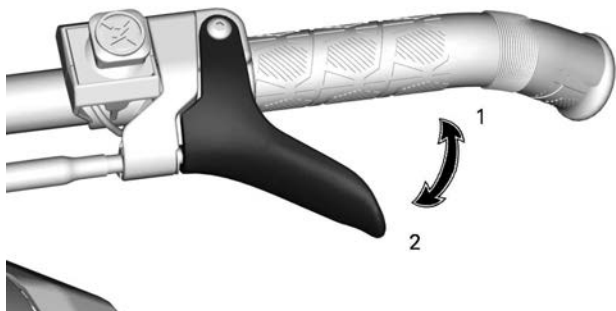

CABLE THROTTLE LEVER

- 1. To accelerate
- 2. To decelerate

Models with 600 ACE or 900 ACE Engine

Designed to be either thumb or finger activated.

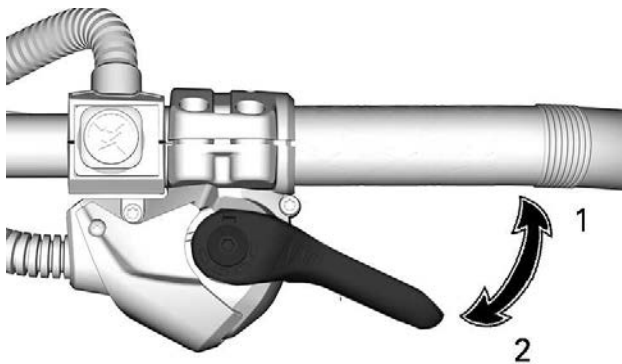

iTC THROTTLE LEVER

- 1. To accelerate
- 2. To decelerate

⚠ WARNING

Test the throttle lever operation each time before starting the engine. The lever must return to the rest position once released. Otherwise, do not start engine.

Switching from Thumb to Finger Throttle Position (iTC Throttle Lever)

⚠ CAUTION

It is highly recommended to immobilize the snowmobile before attempting any modification to the throttle position as it could lead to a hazardous situation.

There are mainly three positions to choose from when going from the thumb to the finger throttle position and the best one will be to the rider's preference and in direct relation with the riding style and conditions.



THUMB THROTTLE POSITION : PUSH DOWNWARD TO ROTATE THROTTLE HOUSING

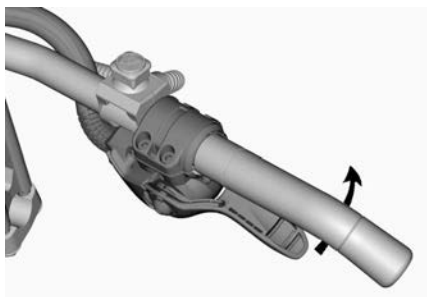

IF WANTED, CONTINUE TO ROTATE THE THROTTLE HOUSING



FINGER THROTTLE POSITION

⚠ CAUTION

It is **HIGHLY** recommended to use gloves and **NOT** mitts when using the finger throttle position.
It is not recommended to use the finger throttle position while riding in dense off trail areas.

The procedure to go back to the thumb throttle position is the reverse of the one shown above.

Emergency Engine Stop Switch

The emergency engine stop switch is located on the RH side of handlebar.

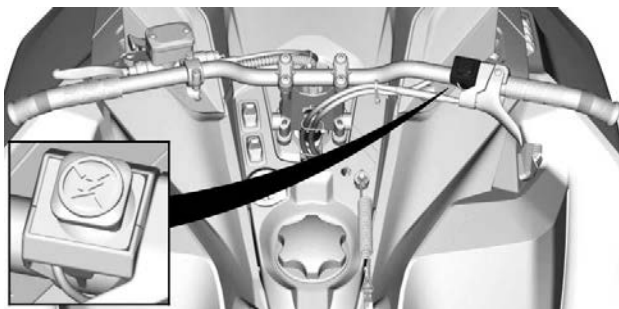

TYPICAL

To stop the engine in an emergency, push the switch down in OFF position and simultaneously apply the brake.



OFF POSITION

To allow engine starting, pull the switch up in ON position.



ON POSITION

All operators of the snowmobile should familiarize themselves with the function of the emergency engine stop switch by using it several times on first outing and whenever stopping the engine thereafter. This engine stopping procedure will become a reflex and will prepare operators for emergency situations requiring its use.

⚠ WARNING

If the switch has been used in an emergency caused by a suspected malfunction, the source of the malfunction should be determined and corrected before restarting engine. Visit an authorized BRP snowmobile dealer for servicing.

Brake Lever

Brake lever is located on the LH side of handlebar.

When squeezed, brake is applied. When released, it automatically returns to the rest. Braking effect is proportional to the pressure applied on the lever and to the type of terrain and its snow coverage.

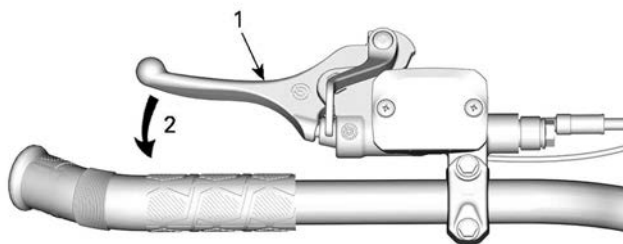

TYPICAL

1. Brake lever
2. To apply brake

Brake Lever Adjustment

⚠ WARNING

It is important to adjust the brake lever to the user size and normal riding position.

Proper brake lever position should allow:

- Good support for the index and middle finger on the lever.
- Use the outer end of the lever to optimize the force.
- Proper wrist alignment.

Taking the time to adjust and try out the brake lever before your first snowmobile outing improves user comfort.



Adjusting the Brake Lever

1. Loosen the two bolts enough to easily move the brake lever on the handlebar.

NOTE:

If the two bolts are not loosened enough the brake lever can leave marks on the handlebar.

Models with steel handlebar

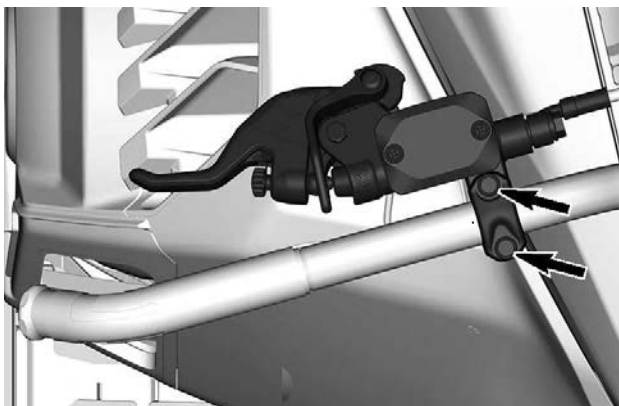

Models with aluminum handlebar and without multifunction switch

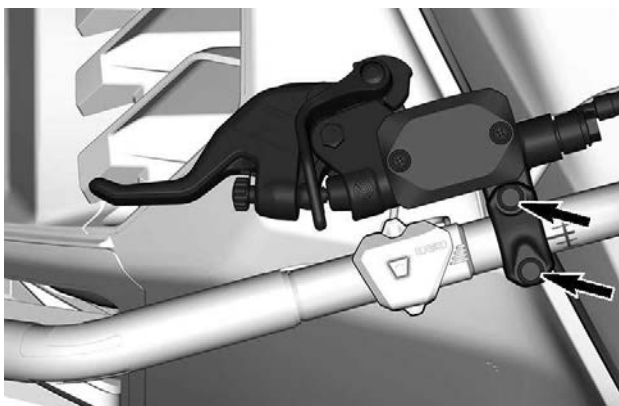

Models with aluminum handlebar and with multifunction switch

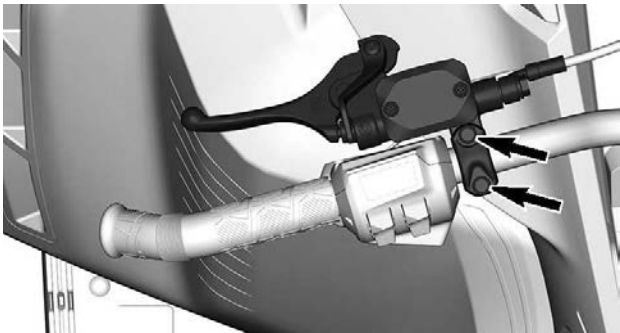

2. Locate the reference mark on the handlebar and respect the distance and rotation limits.

Models with steel handlebar

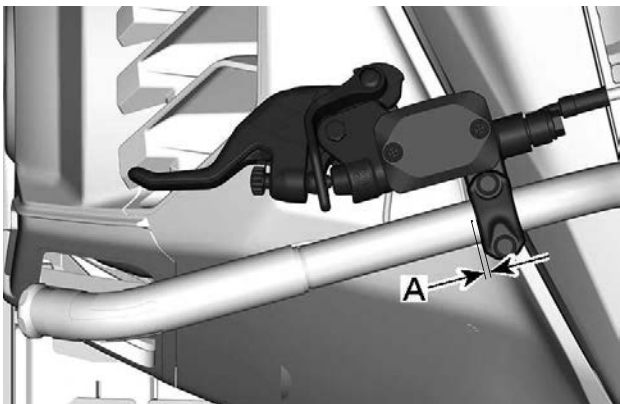

- A. 0 to 5 mm (0 to 0.197 in) between the handlebar point and side of the brake lever

Models with aluminum handlebar and without multifunction switch

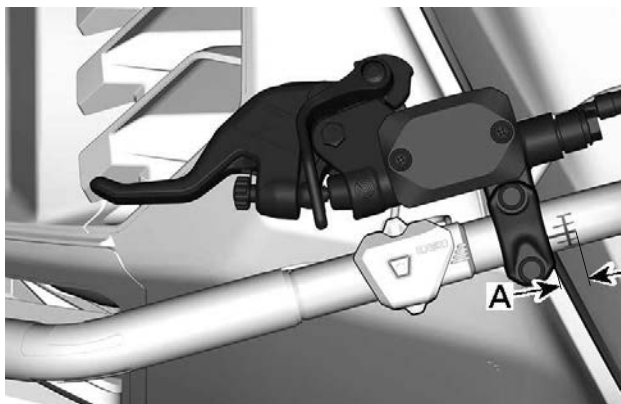

- A. 0 to 9 mm (0 to 0.354 in) between the start of the handlebar mark and side of the brake lever

Models with aluminum handlebar and with multifunction switch



- A. 0 to 15 mm (0 to 0.590 in) between the side of the multifunction switch and the side of the brake lever

3. With the operator on the driver seat, put the brake lever in the desired position.
4. Tighten the two bolts to specification.

TIGHTENING TORQUE	
Brake lever adjustment bolts	8.5 ± 1.5 Nm (75 ± 13 lbf-in)

Parking Brake Lever

Parking brake lever is located on the LH side of handlebar.

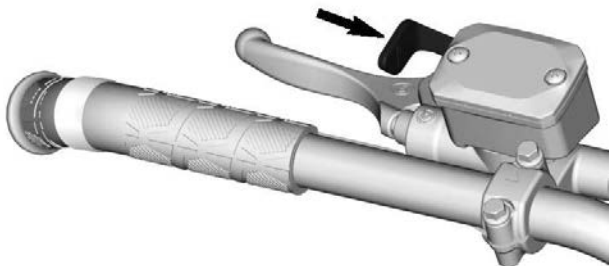

TYPICAL

Parking brake should be used whenever snowmobile is parked.

WARNING

Make sure parking brake is fully disengaged before operating the snowmobile. When you ride the vehicle, brake pads that are caused to drag by a continuous pressure on the lever may cause damage to the brake system and cause loss of braking capacity and/or fire.

To Engage Parking Brake

Apply and hold brake, then lock brake lever using the parking brake lever as shown.

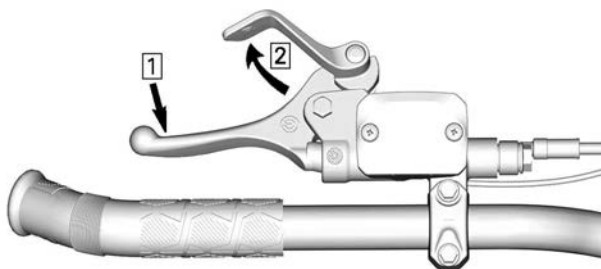

TYPICAL — ENGAGE MECHANISM

1. *Apply and hold brake*
2. *Lock brake lever using parking brake lever*

To Release Parking Brake

Squeeze brake lever. Parking brake lever will automatically return to its original position. Always release parking brake before riding.

Engine Cut-off Switch

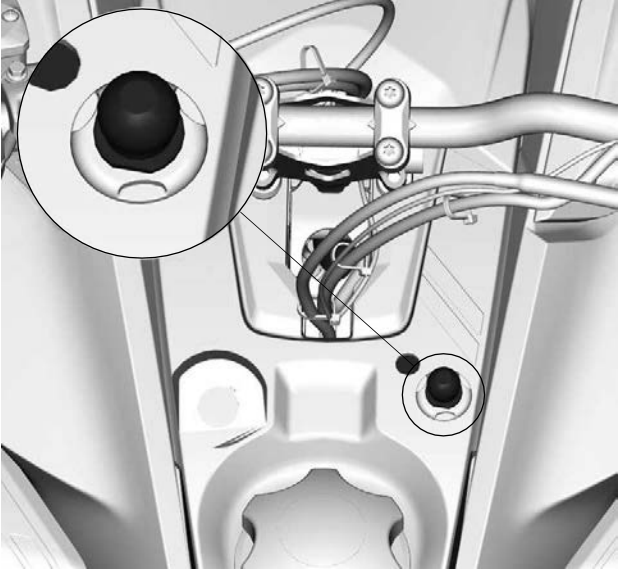

D.E.S.S.

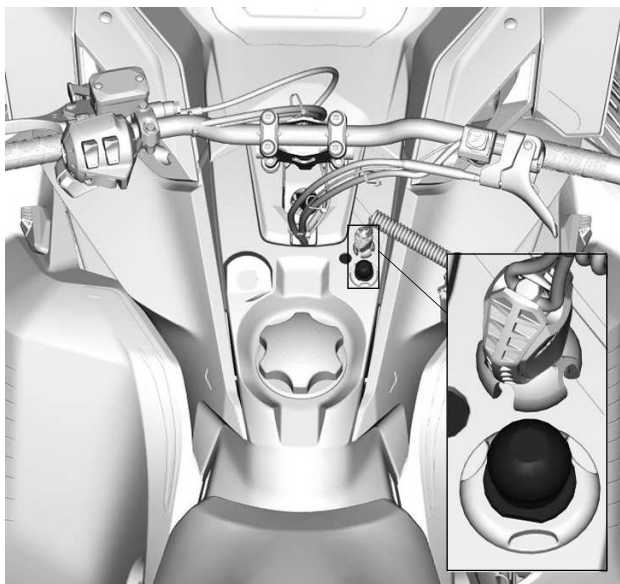

MECHANICAL SWITCH

The engine cut-off switch (tether cord) is located on the console.

The tether cord cap must be securely snapped on the engine cut-off switch to allow vehicle operation.

Pulling the tether cord cap from the switch shuts the engine off.

⚠ WARNING

Always attach the tether cord eyelet to clothing before starting the engine.

D.E.S.S. (Digitally Encoded Security System)

The tether cord cap has an integrated D.E.S.S. key to provide you and your snowmobile with the equivalent security of a conventional lock key.

The D.E.S.S. key contains an electronic chip which features a unique permanently memorized digital code.

Your authorized BRP snowmobile dealer has programmed the D.E.S.S. of your snowmobile to recognize the D.E.S.S. key in the tether cord cap to allow vehicle operation.

If another tether cord is used without programming the D.E.S.S., the engine will start but will not reach drive pulley engagement speed to move vehicle.

Make sure the tether cord cap is free of dirt or snow.

D.E.S.S. Flexibility

The D.E.S.S. of your snowmobile can be programmed by your authorized BRP snowmobile dealer to accept up to 8 different keys.

We recommend the purchase of additional tether cords from your authorized BRP snowmobile dealer. If you have more than one D.E.S.S. equipped BRP snowmobile, each can be programmed by your authorized BRP snowmobile dealer to accept the other vehicles D.E.S.S. keys.

SECONDARY CONTROLS

Some features may not apply to your model or could be optional.

Vehicle safety labels are not shown on illustrations. For information on vehicle safety labels, refer to *Vehicle Safety Labels*.

Handlebar Multifunction Switch

Multifunction switch is located on the LH side of handlebar.

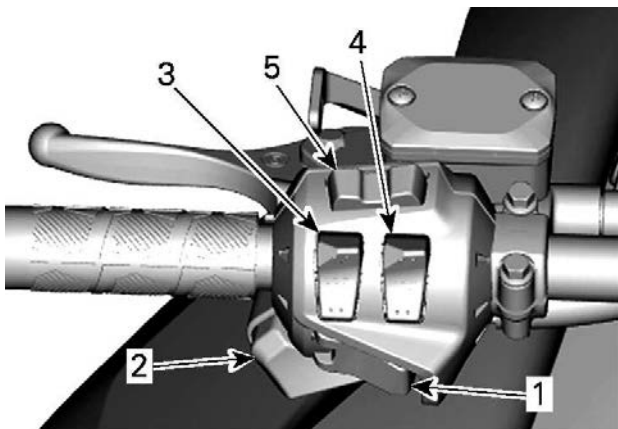

TYPICAL - MODELS WITHOUT THE LARGE PANORAMIC 7.8" WIDE LCD DISPLAY

1. Start/Electronic Reverse button
2. Headlights dimmer switch
3. Heated grips switch
4. Heated throttle lever switch
5. Mode/set button (If equipped)

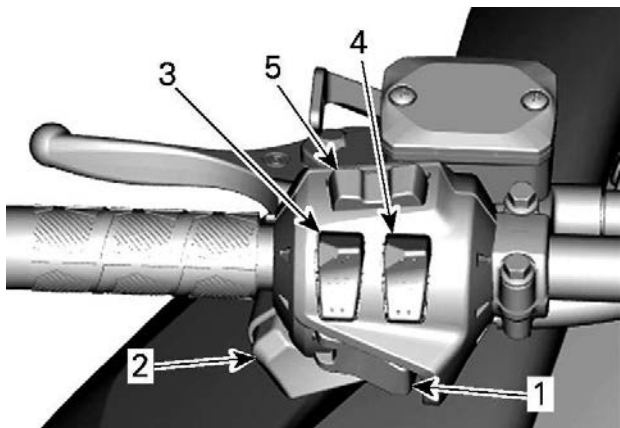

MODELS WITH THE LARGE PANORAMIC 7.8" WIDE LCD DISPLAY

1. Start/Electronic Reverse button
2. Headlights dimmer switch
3. Heated grips switch
4. Heated throttle lever switch
5. Audio Control and Phone call control

Start / Electronic Reverse Button

Press to start engine. Refer to *Engine Starting Procedure* in *Basic Procedures*.

Once engine is started, press to engage the electronic reverse. Refer to *Shifting in Reverse* in *Basic Procedures* for procedure.

Headlights Dimmer Button

Press to select HI or LOW beam. Lights are automatically ON when the engine is running.

Heated Grips Switch

Depress switch as required to select heating intensity to keep your hands at a comfortable temperature.

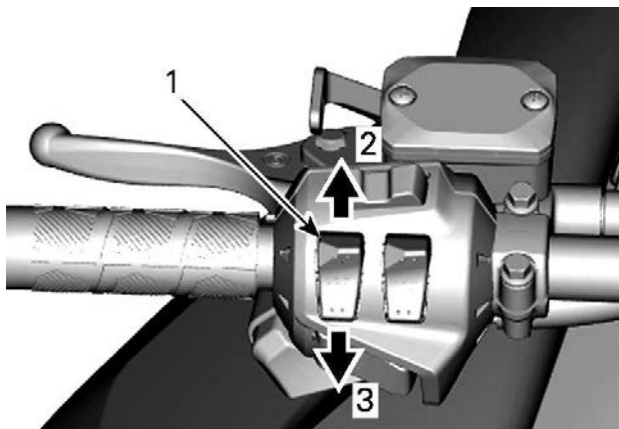

VARIABLE INTENSITY

1. Heated grip switch
2. Increase heat
3. Decrease heat

The heating intensity is displayed via the digital display.

NOTE:

There are ten intensity settings. When released, display will return to fuel level.

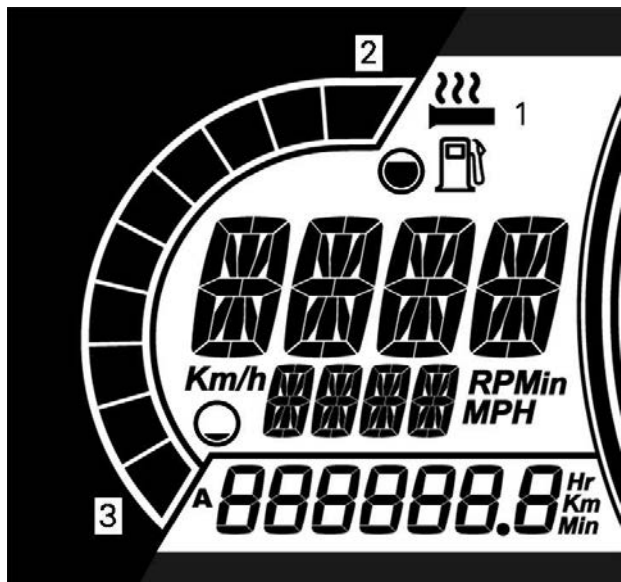

MODELS WITHOUT THE LARGE PANORAMIC 7.8" WIDE LCD DISPLAY SHOWN

1. Heated grip icon
2. More heat
3. Less heat

Heated grips will be in OFF position when there are no bars displayed on the gauge.

NOTE:

For models with the Large Panoramic 7.8" Wide LCD Display, refer to *Large Panoramic 7.8" Wide LCD Display* section.

Heated Throttle Lever Switch

Depress switch as required to select heating intensity to keep your thumb at a comfortable temperature.

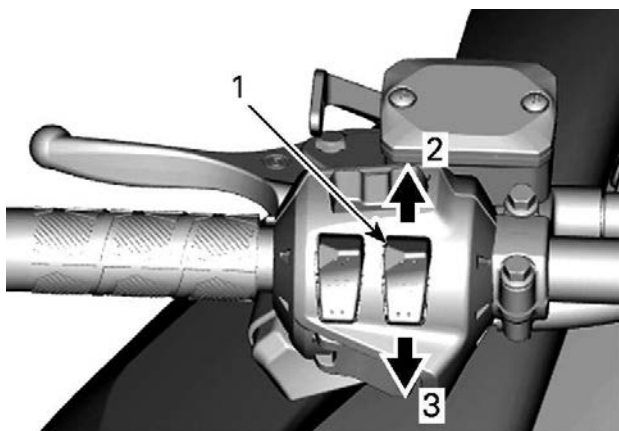

VARIABLE INTENSITY

1. Heated throttle lever switch
2. Increase heat
3. Decrease heat

NOTE:

There are ten intensity settings. When released, display will return to engine temperature.

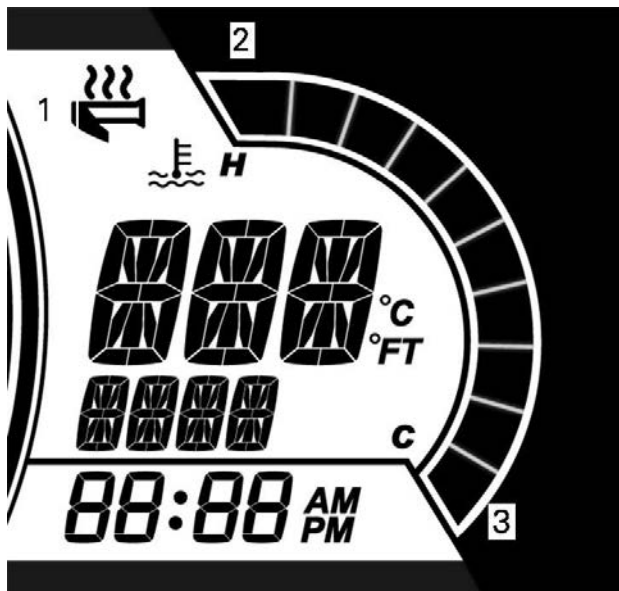

MODELS WITHOUT THE LARGE PANORAMIC 7.8" WIDE LCD DISPLAY SHOWN

1. Heated grip icon
2. More heat
3. Less heat

Heated throttle lever will be in OFF position when there are no bars displayed on the gauge.

NOTE:

For models with the Large Panoramic 7.8" Wide LCD Display, refer to *Large Panoramic 7.8" Wide LCD Display* section.

Menu/Set Button

Models without the Large Panoramic 7.8" Wide LCD Display

This button is used to manage the information displayed on the multi-function gauge.

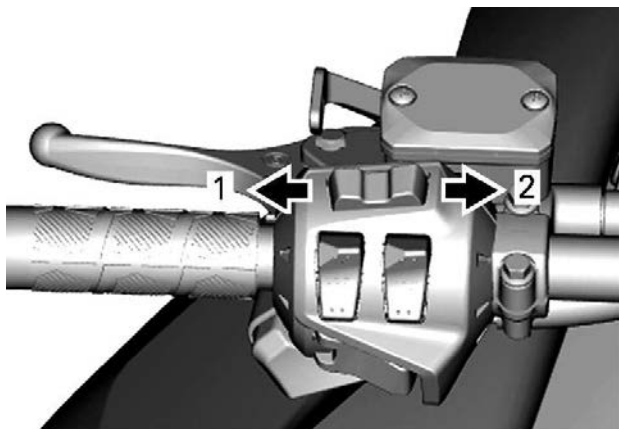

MENU/SET BUTTON

1. Menu function
2. SET function

Refer to *Gauge* for complete information.

Driving Modes

⚠ WARNING

Whenever changing operating mode, make sure to maintain situational awareness while riding.

ECO Mode ***(Fuel Economy Mode)***

When ECO mode is selected (fuel economy mode), vehicle torque and speed are limited whereby an optimal cruising speed is maintained in order to reduce fuel consumption.

Once activated, ECO mode will remain active until it is deactivated by the operator.

Standard Mode

When in Standard mode, no indicator is in the multifunction gauge.

Sport Mode** WARNING**

Ensure passenger is advised to hold on tightly before activating Sport mode. Sport mode provides increased acceleration.

When selected, Sport mode provides for instant throttle response and more rapid accelerations than Standard or ECO mode.

Once activated, Sport mode will remain active until it is deactivated by the operator.

A message of the selected mode will be displayed at activation and deactivation as follow:

Operating mode	Message at Activation
Sport	SPORT MODE
Standard	STANDARD MODE
Eco	ECO MODE

Navigating the Driving Modes

Use ECO/ Standard/ Sport Mode switch to navigate between power levels, from ECO (reduced power) to Standard (full power) to Sport (increased response).

To increase power, press the switch upwards. To decrease power, press the switch downwards.

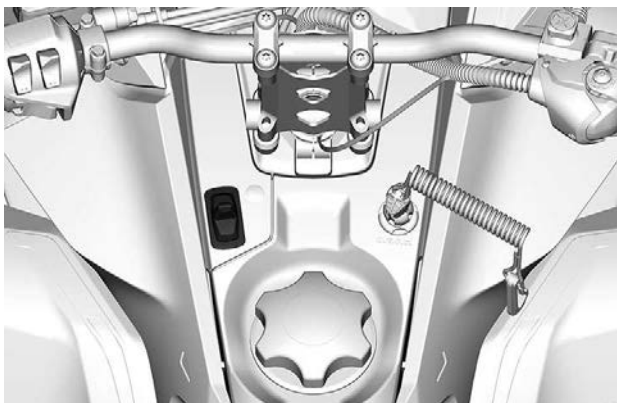

TYPICAL

To activate Standard mode when in Sport mode, press bottom end of switch once.

To activate ECO mode when in Sport mode, press bottom end of switch twice.

To activate ECO mode when in Standard mode, press bottom end of switch once.

⚠ WARNING

Ensure passenger is advised to hold on tightly before activating Sport mode. Sport mode provides increased acceleration.

To activate Sport mode when in Standard mode, press top end of switch once.

To activate Sport mode when in ECO mode, press top end of switch twice.

To activate Standard mode when in ECO mode, press top end of switch once.

⚠ WARNING

When adjusting modes, be sure to maintain situational awareness of other snowmobiles, obstacles, or persons.

Heated Seat Switch (if equipped)

The heated seat switch is located on the console to the left of the steering column.

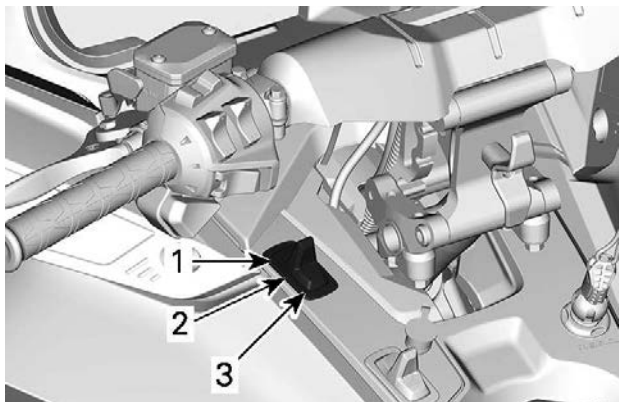

TYPICAL

1. HIGH
2. OFF
3. LOW

Gearshift Lever

Model equipped with Hi/Lo Gearbox

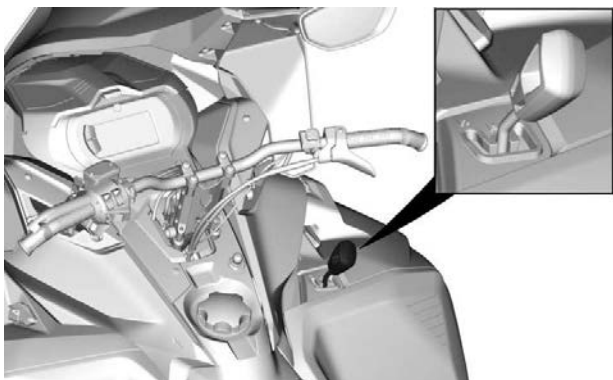

TYPICAL

Use this lever to select gears. The gearbox has two forward gears and a neutral.

Shifting from one position to another is possible at speeds lower than 30 km/h (19 MPH)

⚠ CAUTION

Shifting at a speed faster than 30 km/h (19 MPH) may cause serious damage to the gearbox.

Neutral

The neutral position disengages the gearbox forward gears.

NOTE: The reverse gear still can be activated.

High Range (Forward)

This position selects the high speed range of the gearbox. It is the normal driving speed range. It allows the vehicle to reach its maximum speed.

Low Range (Forward)

This position selects the low speed range of the gearbox. It allows the vehicle to move slowly with maximum torque.

NOTICE

Use the low speed range to pull a cargo carrier, carry heavy cargo, go over obstacles or drive uphill and downhill.

Reverse Lever (if equipped)

Refer to *Shifting in Reverse* in *Basic Procedures* for proper operation.

Horn Button (if equipped)

For vehicles sold in Finland

Press on the horn button to activate the horn.

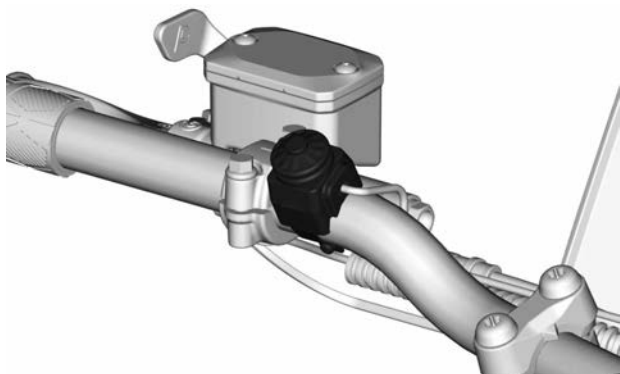

TYPICAL

Passenger Heated Grip Switch (if equipped)

The switch is located on the LH passenger handhold.

Adjust heating intensity as shown.

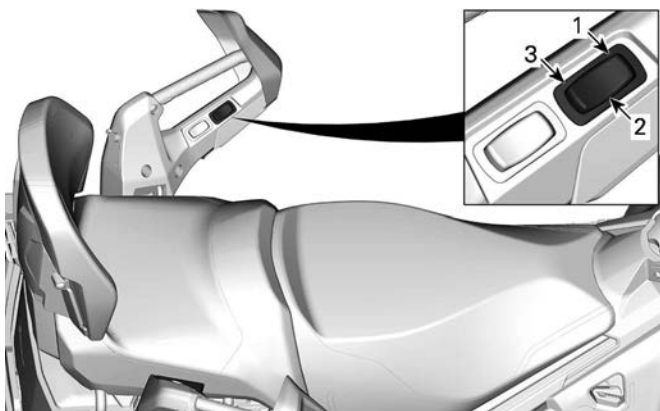

1. *HIGH*
2. *OFF*
3. *LOW*

Passenger Heated Seat Switch (if equipped)

The switch is located on the LH passenger handhold.

Adjust heating intensity as shown.

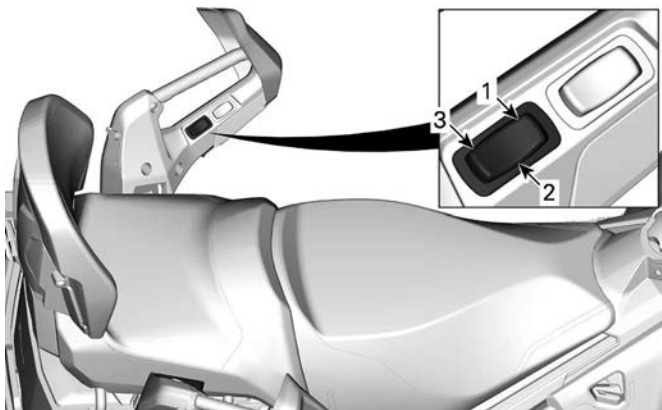

1. HIGH
2. OFF
3. LOW

BODY AND SEAT

Windshield

Removing the Windshield

1. Pull off the deflector pins off the grommets, if applicable.

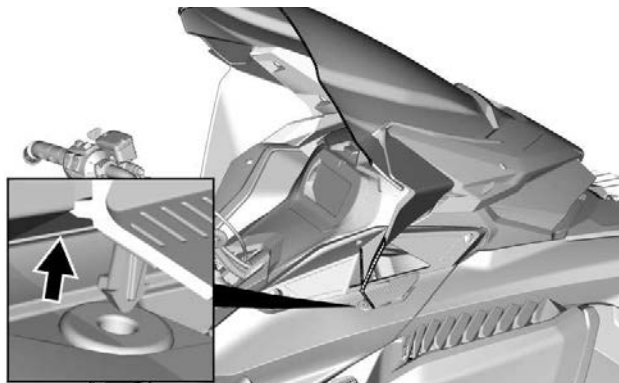

TYPICAL — WITH SIDE DEFLECTORS

2. Place hands on each sides of the windshield.
3. Pull the windshield up until both side pins come out of their rubber grommets.

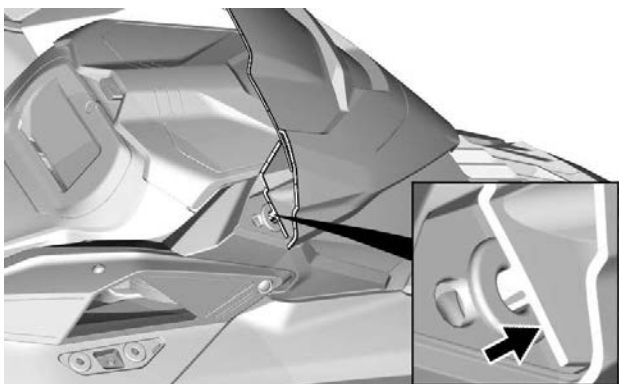

TYPICAL

4. Disengage the center pin or tab, if applicable.

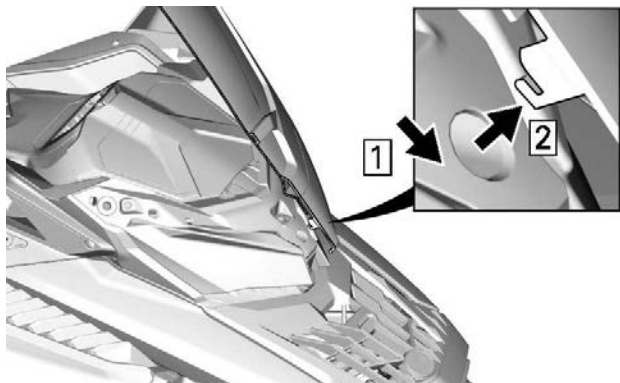

TYPICAL — CENTER TAB - WITH SIDE DEFLECTORS

Installing the Windshield

1. Lubricate the grommets using soapsuds, if required.

NOTICE

Do not lubricate grommets with any type of grease.

2. Insert center pin or tab in headlamp module hole.

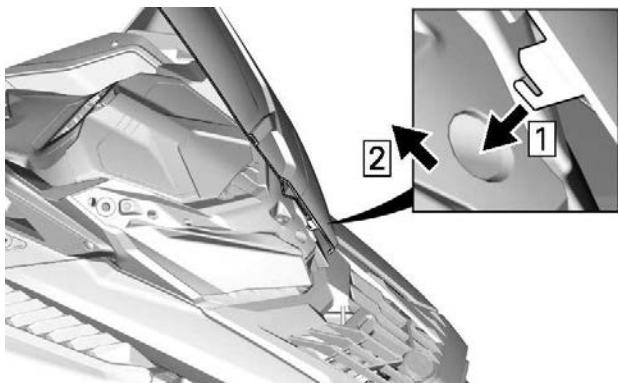

TYPICAL - CENTER TAB - WITH SIDE DEFLECTORS



TYPICAL

3. Secure windshield by inserting the windshield pins into the grommets.

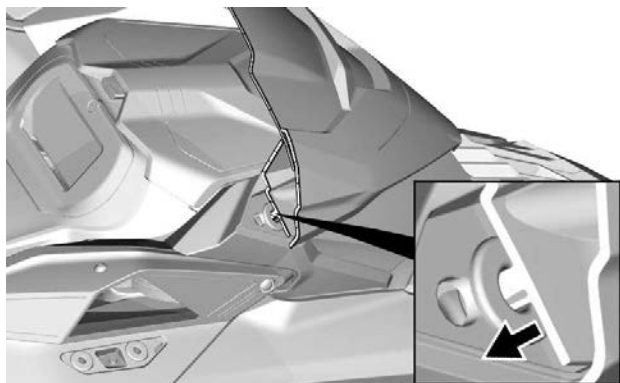
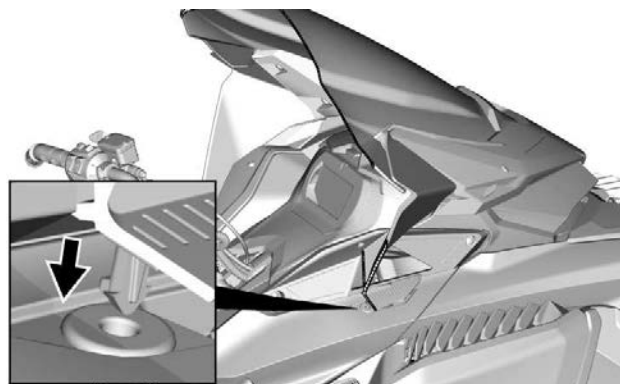
**TYPICAL****TYPICAL — WITH SIDE DEFLECTORS**

Front Storage Compartment

A storage compartment is located at the front of the vehicle, above the gauge.

The Operator's Guide and the emergency starter rope are in the front storage compartment.

To open, push the button and lift the cover.

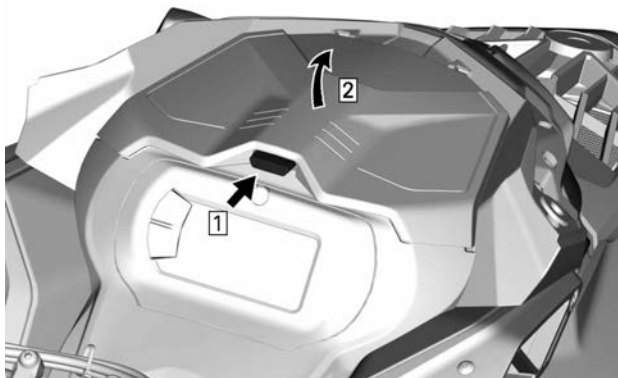

TYPICAL

NOTE:

When closing, make sure cover is secured properly. You will hear a "click".

Hood

Removing the Hood

1. Remove hood screws.

**TYPICAL**

2. Pull the hood forward.

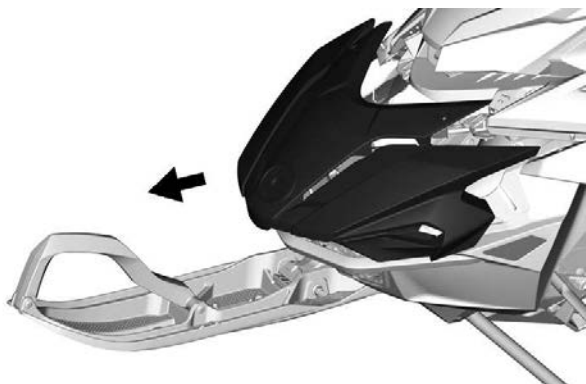
**TYPICAL****Installing the Hood**

1. The installation is the reverse of removal procedure. However, pay attention to the following.

TIGHTENING TORQUE	
Hood Torx screw	2.5 ± 0.2 Nm

Side Panels

! WARNING

Never operate engine with side panels opened or removed from vehicle.

400 mm (16 in.) Tunnel Width

Removing the Side Panels

1. Release all latches, then open panel.

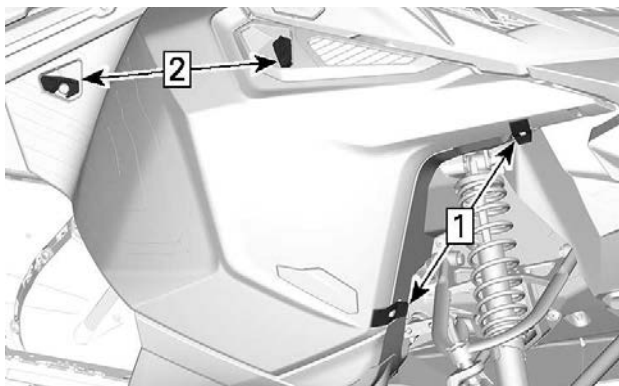

1. Unhook
2. Turn

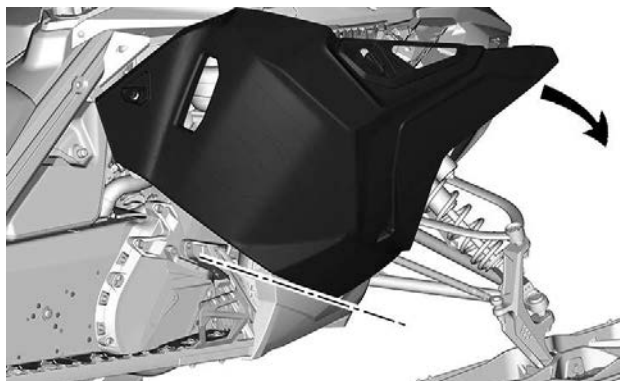
**TYPICAL**

2. Lift the side panel to disengage the tabs.

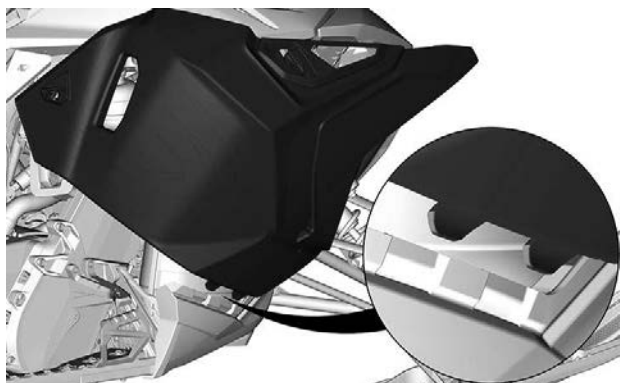

500 and 600 mm (20 and 24 in.) Tunnel Width

Removing the Side Panels

1. Unlock all latches, then open panel.

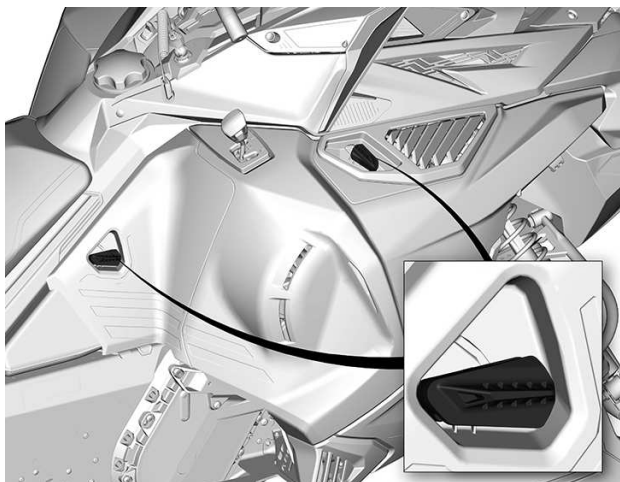

TYPICAL

2. Pivot side panel around lower edge.

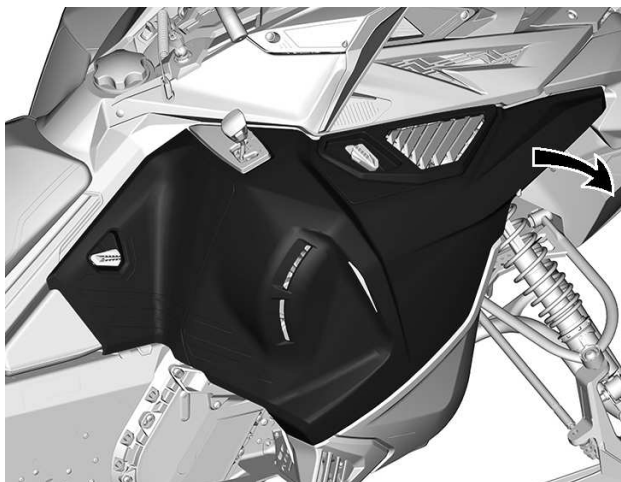

3. Disengage panel tabs.

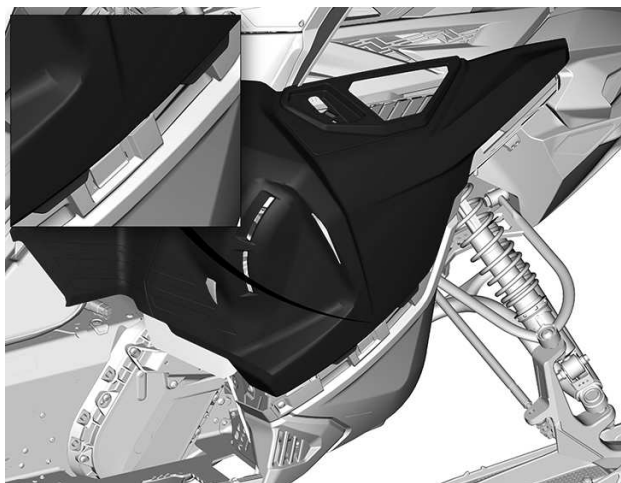

4. Free panel from side hull tab.

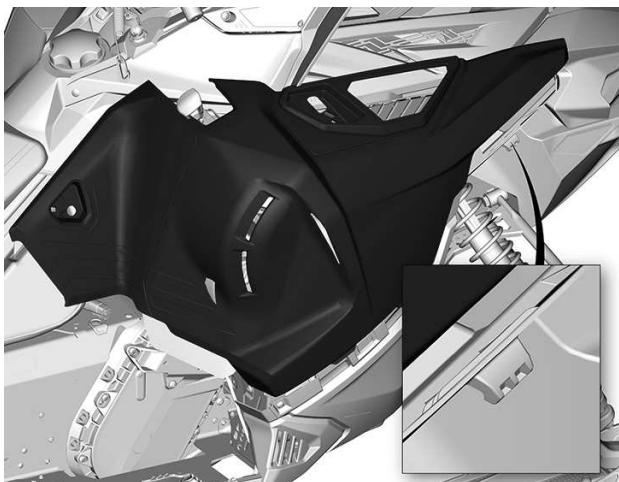

NOTICE

Make sure to place panel in a safe place to avoid scratching.

Installing the Side Panels

The installation is the reverse of the removal procedure.

Upper Body Module

Removing the Upper Body Module

1. Remove:
 - Windshield
 - Hood
 - Side panels
2. Open the storage compartment.

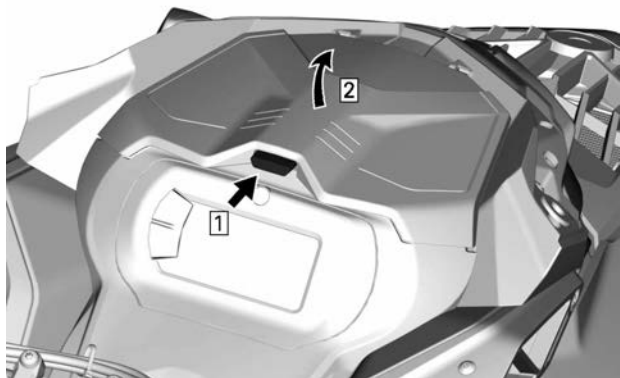

TYPICAL

3. Remove the gauge support retaining screws.



TYPICAL

4. Lift the front of the gauge support, then slide it forward to remove it.

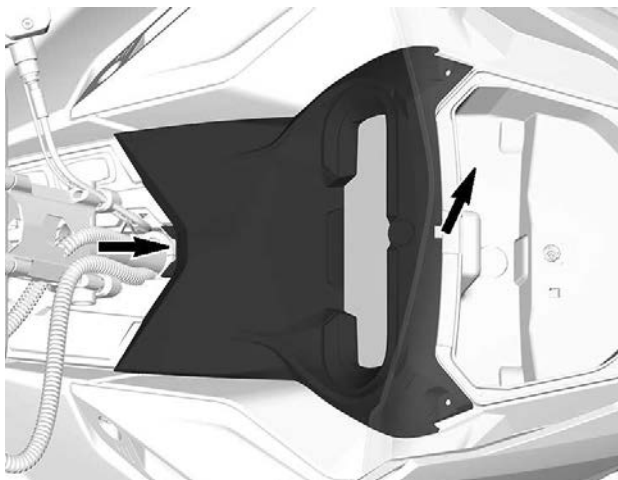

5. Disconnect gauge connector and remove support .
6. Lift storage compartment and disconnect 12V power outlet connectors before removing the storage compartment (if equipped).

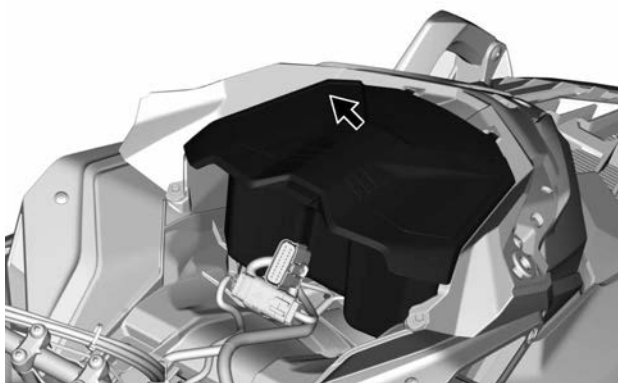

TYPICAL

7. Disconnect the headlight and MAPTS (2-stroke engine) connectors.

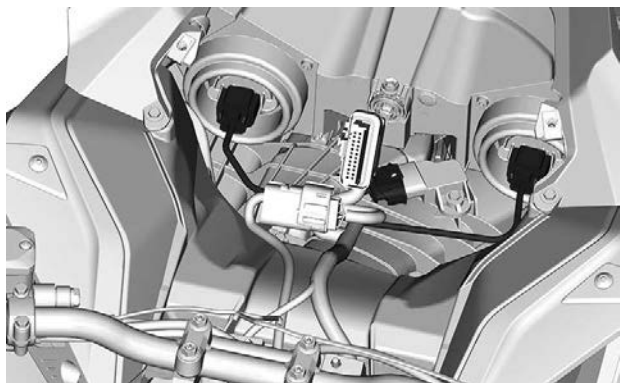

TYPICAL

8. Loosen the air intake duct clamp.

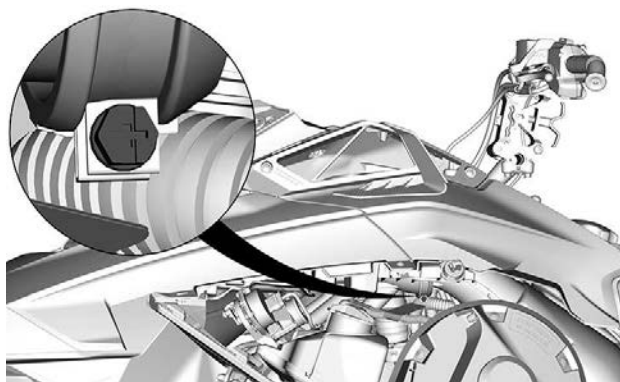

9. Remove the upper body module retaining screws on both sides.

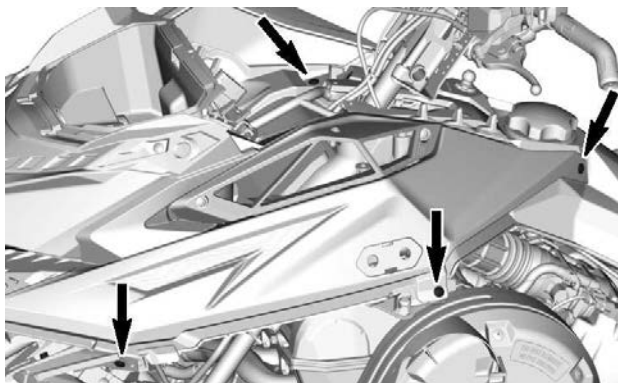

10. Remove the upper body module.

1. Grab the upper body module in the gauge support section.
2. Pull the module forward.
3. Remove the module from the vehicle.

Installing the Upper Body Module

The installation is the reverse of the removal procedure. However, pay attention to the following.

1. Lower the upper body module in place.

NOTE:

Make sure the air intake duct is positioned correctly in the boot.

2. Tighten air intake duct clamp.

TIGHTENING TORQUE	
Duct clamp	$1 \pm 0.2 \text{ Nm}$

3. On both sides, install the upper body module retaining screws.
4. Connect the IR light connector.
5. Install the hood.

TIGHTENING TORQUE	
Upper body screws	$2.5 \pm 0.2 \text{ Nm}$

6. Connect the headlight connectors.
7. Install the storage compartment but leave the cover open.
8. Install gauge, secure with the screws.

TIGHTENING TORQUE	
Gauge screws	2.5 ± 0.2 Nm

9. Install:
 - Side panels
 - Hood
 - Windshield

Seat

400 mm (16 in.) Tunnel Width

Removing the Seat (tab lock)

From between the fuel tank and the seat front end, pull the locking tab upwards.

Slide the seat backwards while holding the tab up.

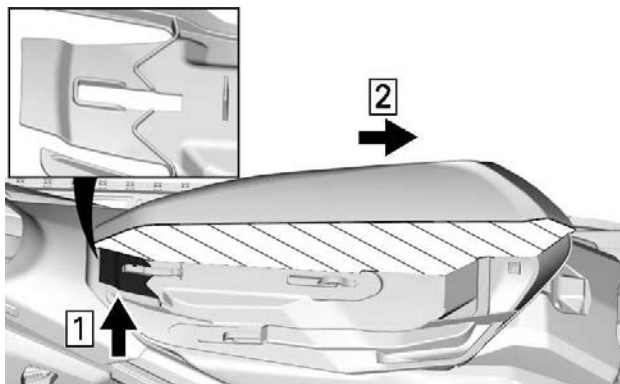

TYPICAL — CROSSCUT VIEW OF SEAT FOAM

1. Pull upwards
2. Slide backwards

Installing the Seat (tab lock)

NOTICE

Riding the vehicle with any objects between the seat and the fuel tank could damage the fuel tank. **NEVER** place any objects between seat and fuel tank.

Place seat over the hooks, then slide it forward until the tab locks over the front hook.

WARNING

Make sure seat is securely latched before riding.

Backrest (if equipped)

Removing the Backrest

1. Disengage the LinQ lever cap on both sides.

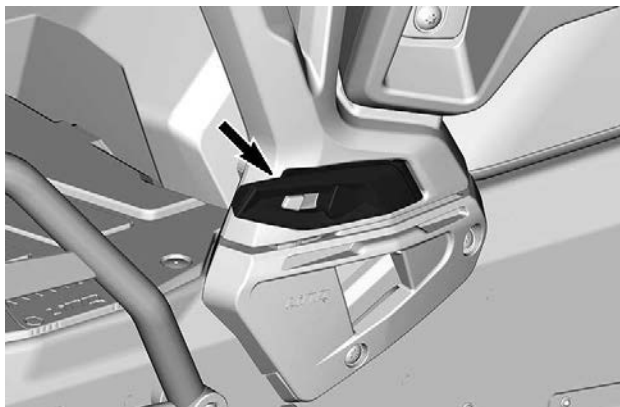

2. Unlock the LinQ on both sides.

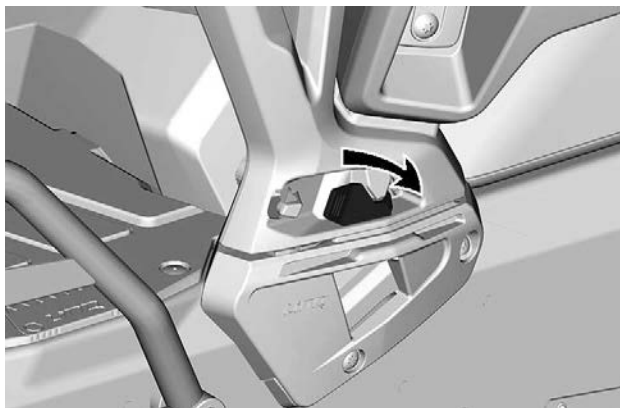

3. Pull the backrest upwards to remove..

Installing the Backrest

The installation is the reverse of the removal procedure.

Passenger Handholds (if equipped)

The passenger handholds provide a strong holding point and comfort for the passenger on long rides.

Adjusting the Passenger Handholds

To adjust the handhold height, proceed as follows:

1. Remove the screws.

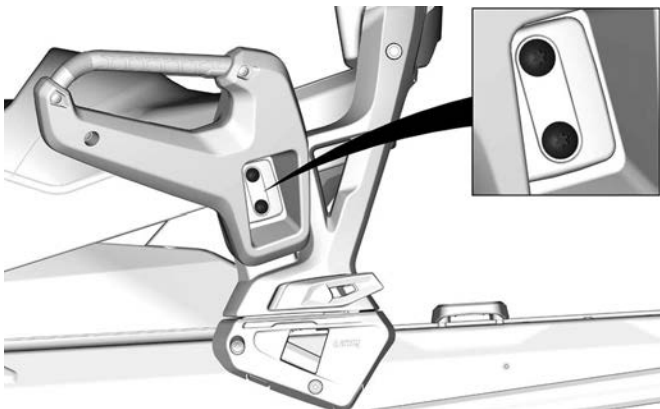

2. Raise or lower the handhold to suit passenger's comfort.

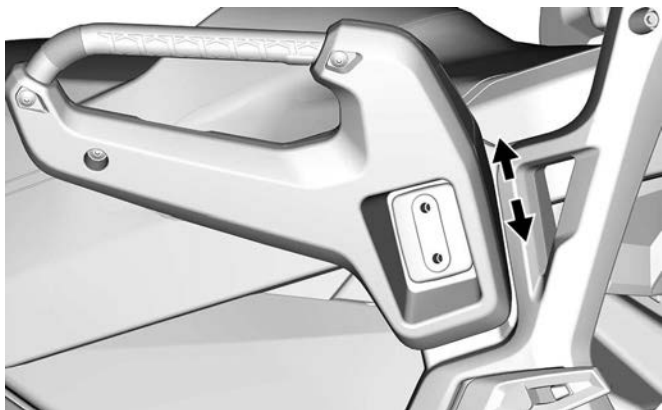

3. Reinstall the screws. Tighten to specification.

Tightening Torque	
Handhold screw	24.5 ± 3.5 Nm (18 ± 3 lbf-ft)

500 and 600 mm (20 and 24 in.) Tunnel Width

Operator's Seat

Removing the Seat

Release the latch at the back of the seat.

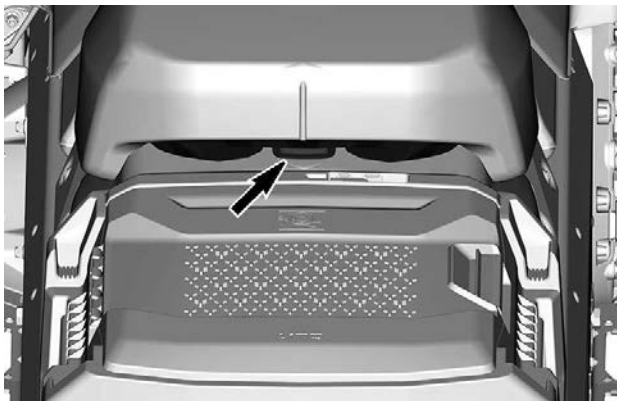

Slide seat rearwards to remove it.

Installing the Seat

NOTICE

Riding the vehicle with any objects between the seat and the fuel tank could damage the fuel tank. **NEVER** place any objects between seat and fuel tank.

Place seat over the hooks, then slide it forward.

Securely engage the latch.

! WARNING

Make sure seat is securely latched before riding.

Passenger Seat (if equipped)



⚠ WARNING

Any passenger must be able to firmly lay his feet on the footrests and keep his hands on the handholds at all times when seated. Respecting those physical criteria is important to ensure that the passenger is stable and to reduce the risks of ejection.

Removing the Passenger Seat

1. Unlock seat latch on both sides.

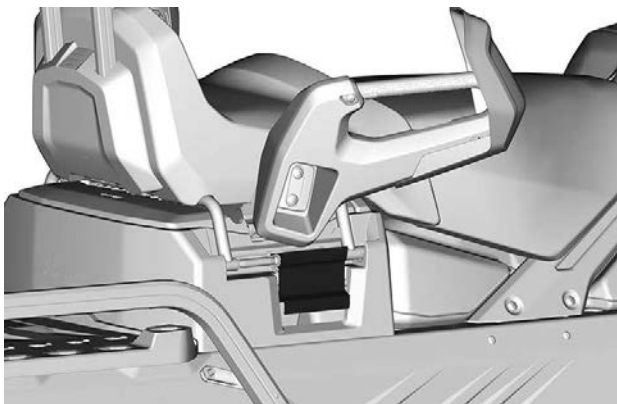

TYPICAL

2. Lift the seat to disconnect the electrical connector.
3. Remove passenger seat.

Installing the Passenger Seat

The installation is the reverse of removal procedure. However, pay attention to the following.

Ensure to reach the second step when latching.

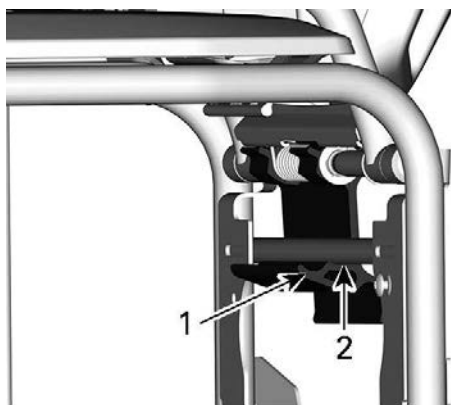

1. First step
2. Second step

 **WARNING**

Ensure the latch is on the second step before riding.

EQUIPMENT

Some features may not apply to your model or could be optional.

Operator's Guide

The Operator's Guide should be stored in the *Front Storage Compartment*.

Power Outlet - USB (if equipped)

The USB power Outlet is located in the front storage compartment. It allows to charge your cell phone while stored in the heated cell case.

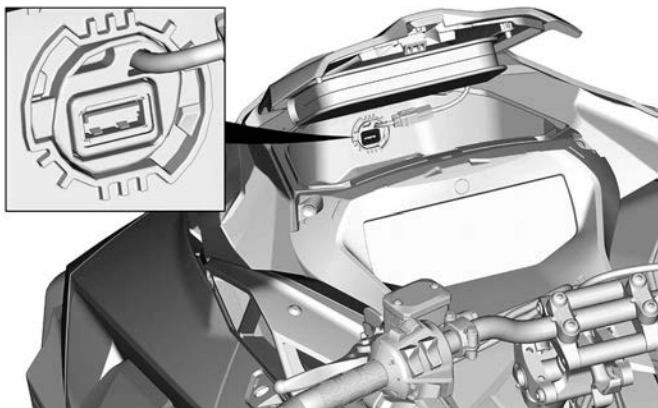

Adjustable Mirrors (if equipped)

Each mirror can be adjusted to suit operator's preference.

 **WARNING**

Adjust with vehicle at rest in a safe place.

When installing a cover, the mirrors can be tilted downward to ease installation.

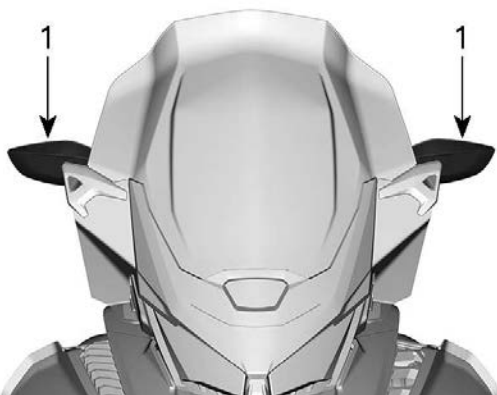

TYPICAL
1. Mirrors



TYPICAL

Mountain Strap

This handlebar strap shall be used only to provide additional pulling force when snowmobile is stuck in a slanted position. On an exceptional basis it can be used at very slow speed only, when standing on the right running board to bring the vehicle back on its desired path.

When riding, both hands should remain on the handlebar grips to provide braking capability, as well proper steering and directional control. Do not use handlebar strap for towing, lifting or side hilling.

⚠ WARNING

Do not use while riding at speed. Steering control is highly reduced and brake control is not possible.

Electric Visor Jack Connector

An electric visor can be connected to the jack connector. A stress relief extension is supplied with the vehicle.



TYPICAL — DRIVER - ELECTRIC VISOR JACK CONNECTOR LOCATION

Drive Belt Guard

Removing the Drive Belt Guard

⚠ WARNING

NEVER operate engine:

- Without shields and belt guard securely installed.
- With hood and/or side panels opened or removed.

NEVER attempt to make adjustments to moving parts while engine is running.

NOTE:

Belt guard is purposely made slightly oversize to maintain tension on its pins and retainers preventing undue noise and vibration. It is important that this tension be maintained when reinstalling.

Remove tether cord cap from engine cut-off switch.

Open the LH side panel. See procedure in this section.

Remove retaining pin.

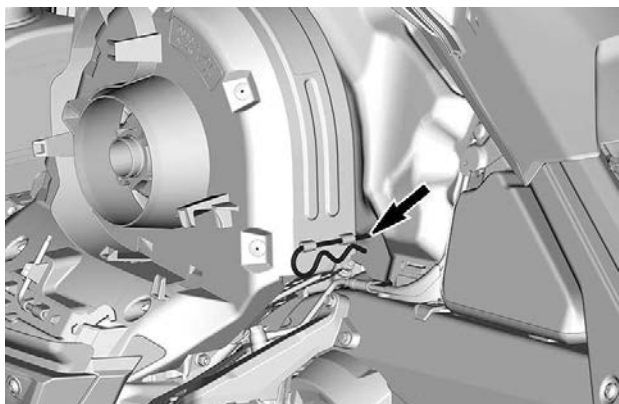
**TYPICAL**

Lift rear portion of guard then release from front tab.

Installing the Drive Belt Guard

1. Insert belt guard tab in front support slot.

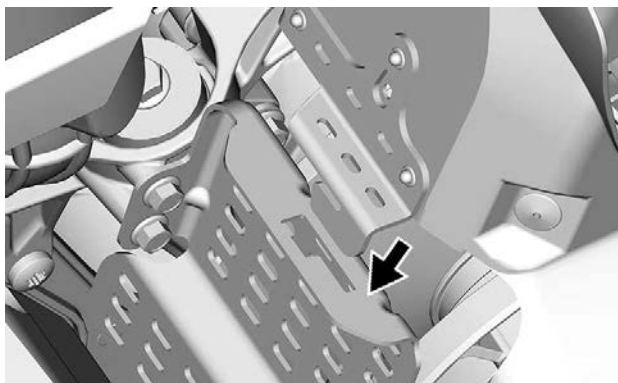

-
2. Push drive belt guard toward engine then toward front of vehicle.

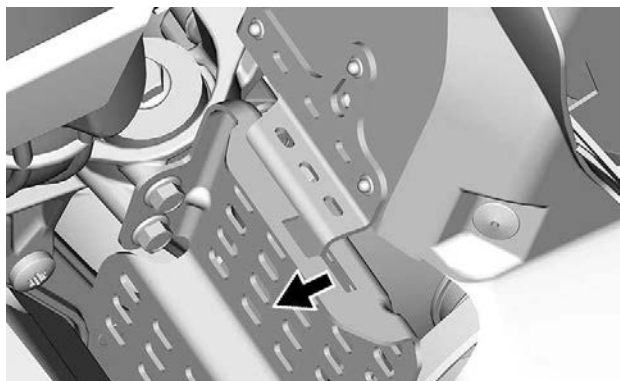
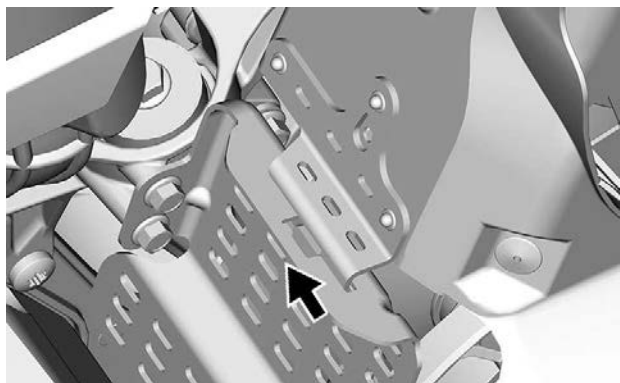

3. Insert belt guard tab between bottom pan and hook.

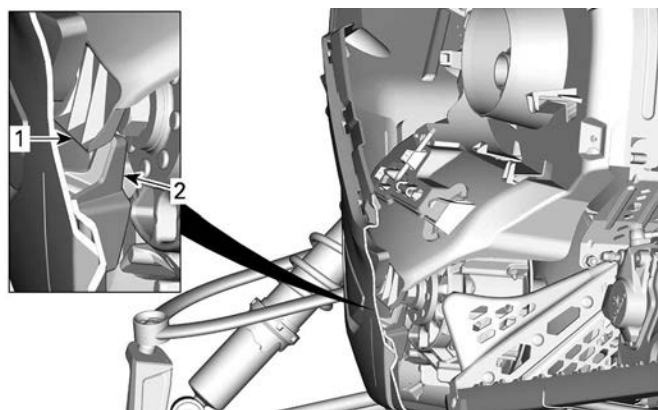
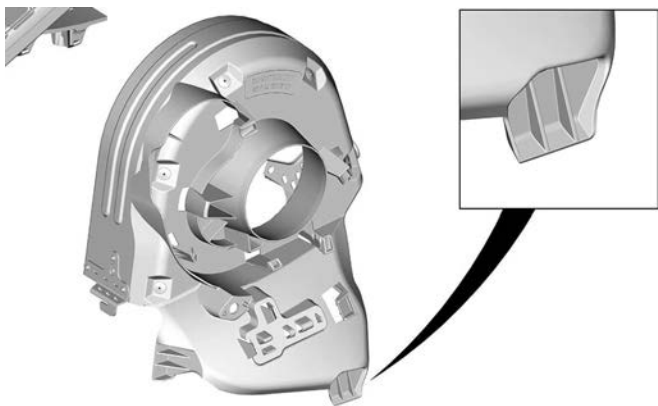

LH SIDE BOTTOM PAN - CROSSCUT VIEW

1. Belt guard tab
2. Bottom pan hook

4. Position the rear portion of the belt guard over the retainer and secure it using the retaining pin.

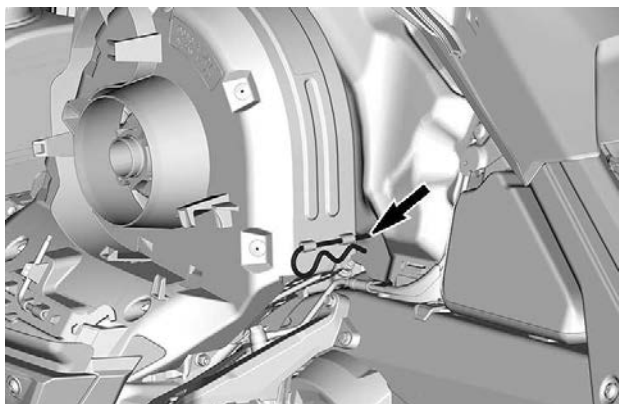

Spare Drive Belt Holder

A spare drive belt can be stored in a holder located on the drive belt guard.

NOTE:

The spare drive belt is not supplied with the snowmobile.

Position spare drive belt into drive belt guard slot.

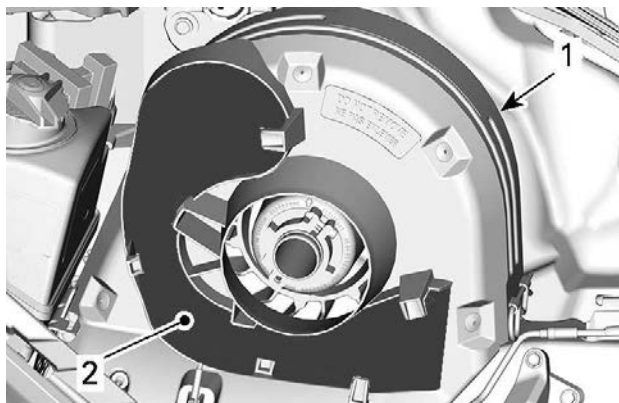

TYPICAL

1. Drive belt guard
2. Slot

Secure in place by sliding it behind the tabs.

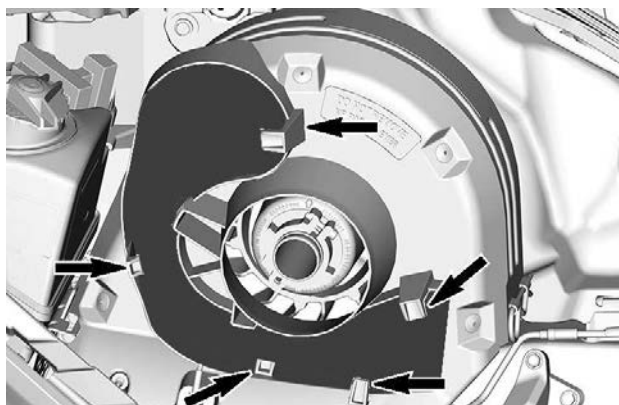

TYPICAL

Tools

A part of the drive belt guard is designed to hold the tools allowing for basic maintenance.

The tools are supplied with the vehicle. They should always be installed in their proper location and orientation.

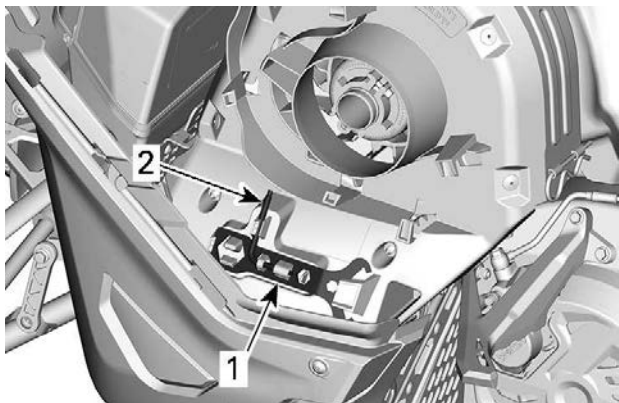

TYPICAL - DRIVE BELT GUARD TOOLS LOCATION

1. *Suspension adjustment tool*
2. *Pulley expander and headlight adjustment tool*

Install in the following sequence:

⚠ CAUTION

Make sure tools are secured properly. Tools may detach and cause damage to rotating parts.

1. Slide the suspension adjustment tool open end under retaining tab.

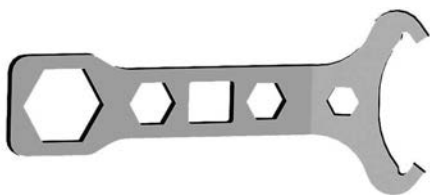

SUSPENSION ADJUSTMENT TOOL

2. Press the closed end on the retaining tabs.

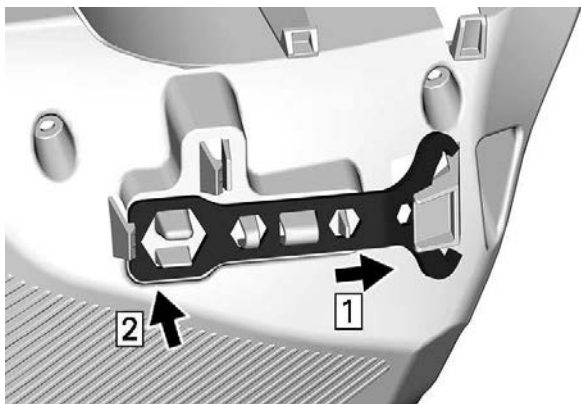

3. Slide the Pulley expander and headlight adjustment tool short end into hole.

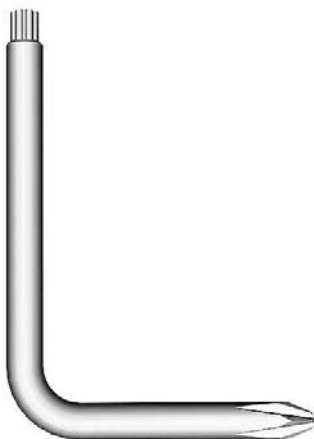
**PULLEY EXPANDER AND HEADLIGHT ADJUSTMENT TOOL**

4. Rotate and clip long end in place.

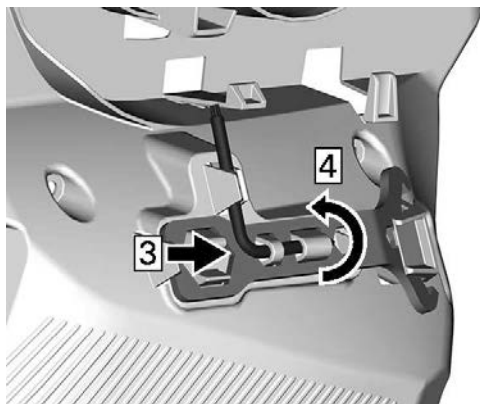
**Rear Storage Compartment (if equipped)**

A storage compartment is located at the rear of the seat, above the battery cover.

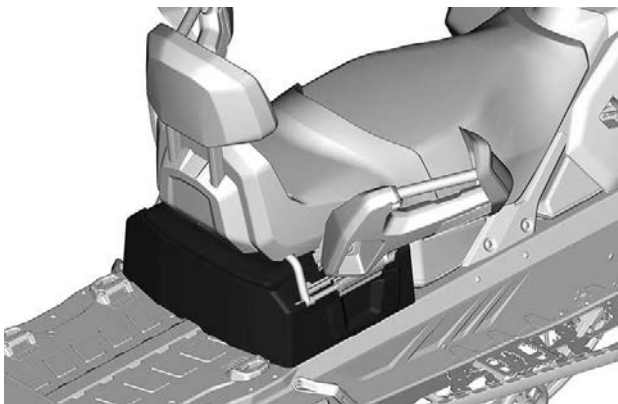

TYPICAL

To open, tilt passenger seat.

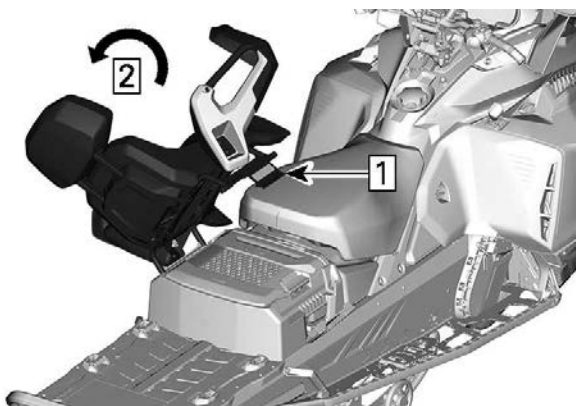

TYPICAL

1. Unlock seat latch
2. Tilt passenger seat

Lift handle.

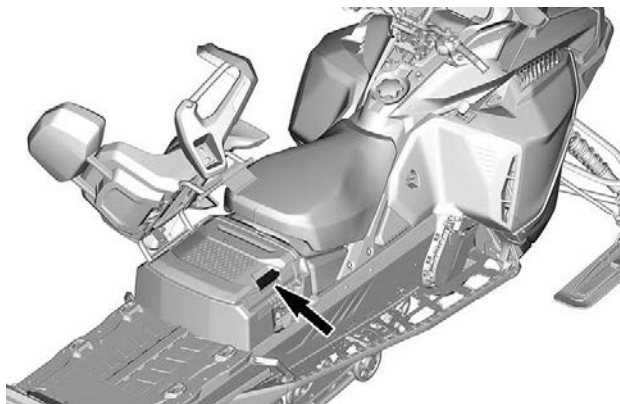

TYPICAL

Cargo Box (if equipped)

The cargo box is secured by LinQ attachment. To Install, follow the steps.

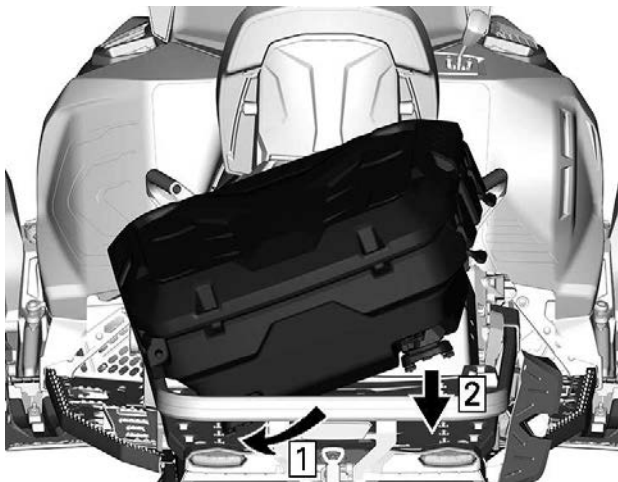

1. Slide cargo bag toward LH side.
2. Lower cargo bag.

Turn LinQ levers as shown to lock.

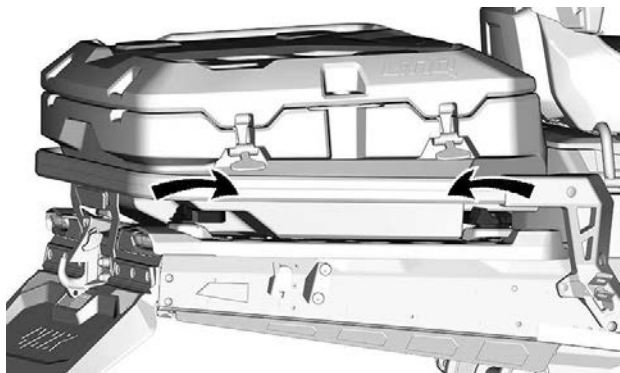

Hitch

NOTE:

Refer to decal on vehicle for towing weight capacities.

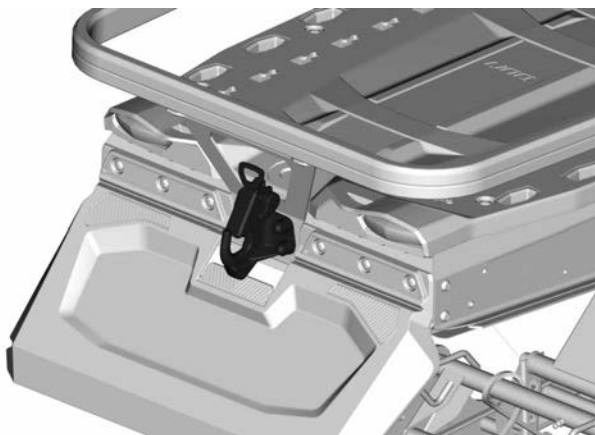

To open the hook, push and turn the handle to retract locking plate.

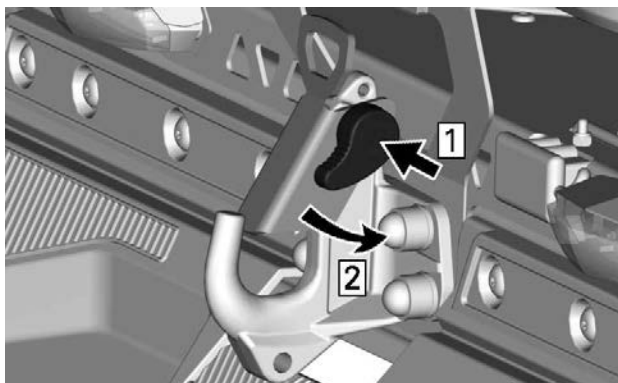

When attaching any accessory, always refer to the manufacturer's recommendations.

 **WARNING**

Never tow an accessory with a rope. Always use a rigid tow bar. Using a rope would result in a collision between the object and the snowmobile and possibly in a tip over in case of a rapid deceleration or on a downward slope.

GAUGE – 4.5" DIGITAL DISPLAY

Multifunction Display

Lower Display

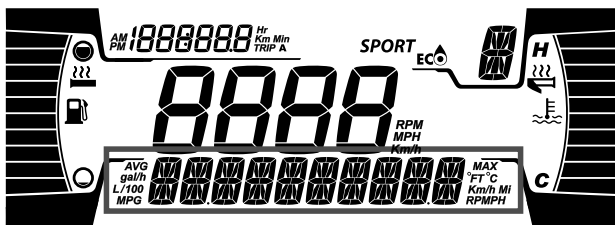
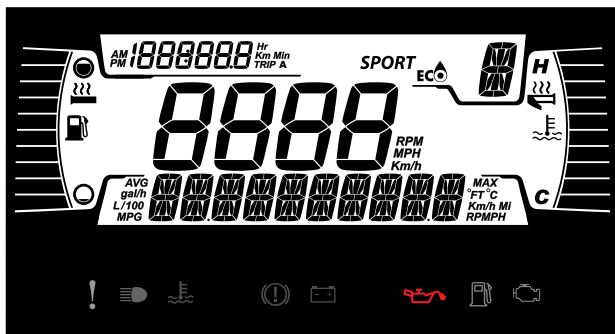

May display the following:

- RPM
- Speed
- Engine Temperature
- Fuel Statistics
- Settings
- Messages
- Outside temperature (if equipped)

To change the displayed information, use the gauge LOWER (M) button, or the Mode button on the handlebar multifunction switch, if equipped.

The SPEED STAT display shows the maximum and the averaged speed. Hold LOWER button for 3 seconds to reset.

When the SPEED display is chosen, the RPM is shown in the TRIP display.

Left Lateral Display

The left lateral display includes:

- Fuel level indicator
- Heated Grip level

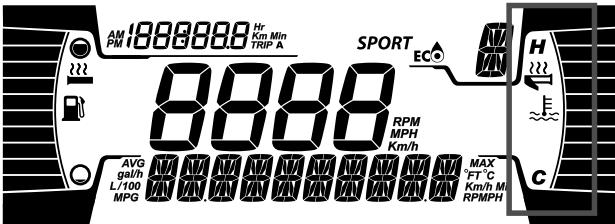
Right Lateral Display

The right lateral display includes:

- Engine Temperature
- Heated throttle indicator

Central Display

Display the RPM of the engine or the vehicle speed in Km/h or MPH.

Driving Mode Display

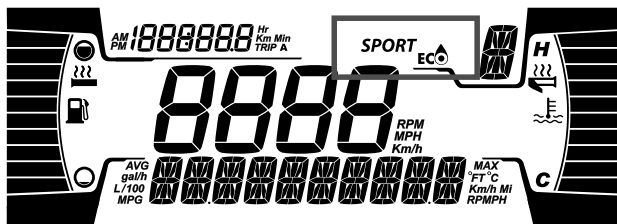

The MODE display indicates the selected mode of operation:

- SPORT
- ECO
- STANDARD

NOTE:

When in STANDARD mode, no information is displayed.

A message of the selected mode will be displayed on the lower display at activation and deactivation as follow:

DRIVING MODE	MESSAGE AT ACTIVATION	MESSAGE AT DEACTIVATION
Sport	Sport	Sport OFF
Eco	Eco	Eco OFF

Trip Display

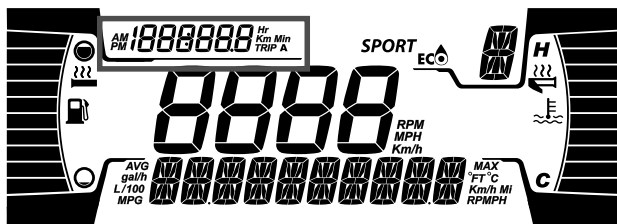

This display shows trip informations:

- Cumulative distance odometer
- Trip A hours

- Trip A distance (Km or mph)
- Vehicle hour meter
- Clock (If battery equipped)

To change the displayed information, use the gauge UPPER (T) button, or the Trip button on the handlebar multifunction switch, if equipped.

Warning Lamps and Indicators







The following indicator lamps will alert you to a vehicle condition that may become serious. Some lamps will illuminate when starting the vehicle to make sure they work. If any lamps remain on after starting the vehicle, refer to the respective system warning lamp for further information.



NOTE:

Some warning indicators appear in the display of the multifunction gauge and function the same as an indicator lamp but do not display when starting the vehicle.

Telltale Lights - Lower Bar



Lights	Description
	ORANGE - Vehicle malfunction
	BLUE - The high beam are selected
	RED - The engine temperature is too high.
	RED - Parking brake is engaged or malfunction of the brake system
	RED - The battery voltage too low or problem with the electrical system
	RED - Low engine oil pressure (if applicable)

Lights	Description
	ORANGE - Low fuel level
	<p>ORANGE</p> <p>Turn on: Malfunction of the vehicle emissions control system</p> <p>Blink: Engine problems, the limp home mode is activated. Have the vehicle serviced immediately.</p>

Icons and Indicators - Multifunction Display

Icons and Indicators	
SPORT	Denotes SPORT mode is selected.
	Denotes ECO mode is selected.

Settings

Setup

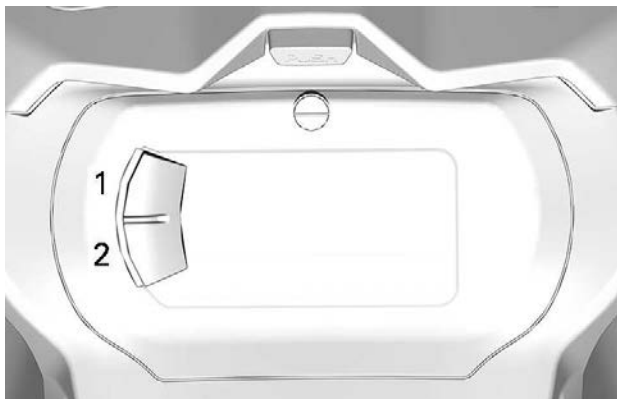

1. Upper button (Trip)
2. Lower button (Menu)

NOTE: A Trip and a Menu buttons can be found on the handlebar multifunction switch, if equipped.

Using the LOWER (M) button, select **SETTINGS** and hold to enter setting menu.

Reset Stats

Using LOWER button, select **RESET STAT** and hold to reset.

Unit Selection

This multifunction gauge is factory preset in metric units but it is possible to change it to imperial units.

Using LOWER button, select **UNITS** and hold button to change units.

Setting Clock

Using LOWER button, select **CLOCK** to change the clock.

1. Press LOWER button to select clock display.
2. Push and hold LOWER button for 1 second.

3. Press LOWER button to select 12:00 AM PM or 24:00 time base.
4. Push and hold LOWER button to acknowledge selection.
5. Press LOWER button to change hours (hours flash).
6. Push and hold LOWER button to acknowledge hour selection.
7. Press LOWER button to switch to minutes (minutes flash).
8. Push and hold LOWER button to acknowledge minutes selection.

Setting Language

The gauge display language can be changed. Refer to an authorized BRP snowmobile dealer for language availability and to setup the gauge to your preference.

GAUGE – 7.2” DIGITAL DISPLAY

Multifunction Display

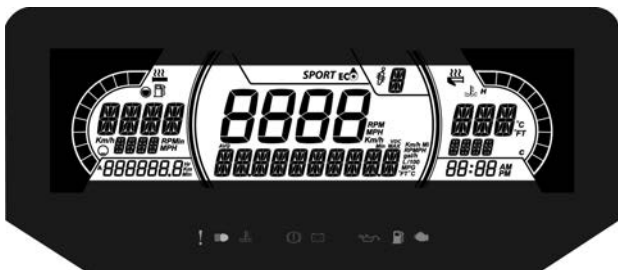

1. Select the upper or center display by using the MENU (M) button on the multifunction switch. Refer to *Secondary Controls* for Menu/Set button location.
2. While the desired display is flashing, navigate through the display, by using the SET (S) button on the multifunction switch.

Once the desired information is displayed, press the MENU (M) button or wait 5 seconds to confirm.

To reset

- Average speed
- Top speed
- Total fuel consumption

Press and hold the SET (S) button while display is flashing.

Lower Display

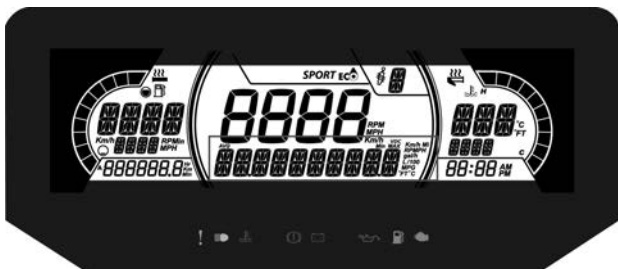

7.2" DIGITAL LOWER DISPLAY

May display the following:

- Settings

- Messages

The SPEED display shows the Maximum and the averaged speed. Hold MENU button for 3 seconds to reset.

Left Lateral Display

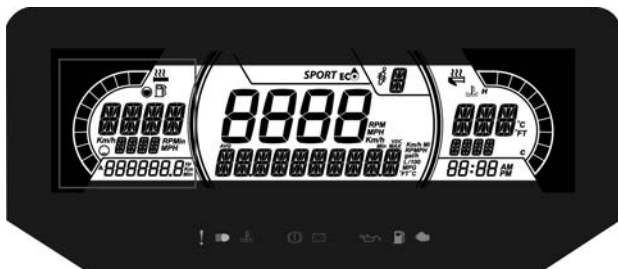

The left lateral display includes:

- Fuel level indicator
- Heated Grip level
- Trip distance A and B (Km or mph)
- Cumulative hours
- Speed
- RPM
- Odometer

Right Lateral Display

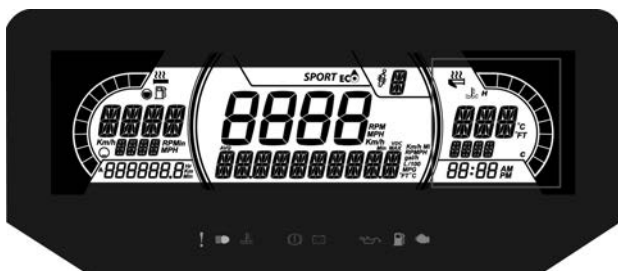

The right lateral display includes:

- Engine Temperature
- Heated throttle indicator
- Clock

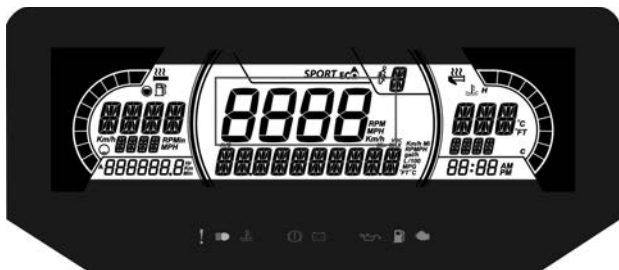
Central Display

Display the vehicle speed in Km/h (or MPH) or the RPMs. Refer to *Settings*.

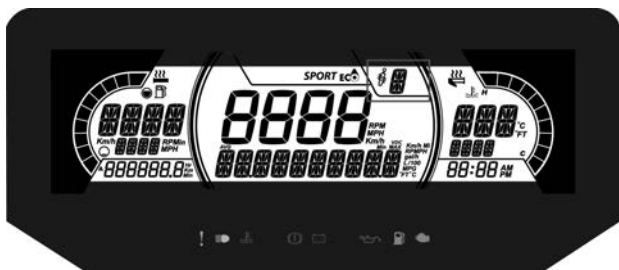
ACS Suspension Position Display (if equipped)

This display shows suspension setting.

The suspension is calibrated from 1 to 5, 1 being the softest setting.



Refer to *TUNE YOUR RIDE* section for proper adjustment procedure.

Driving Mode Display

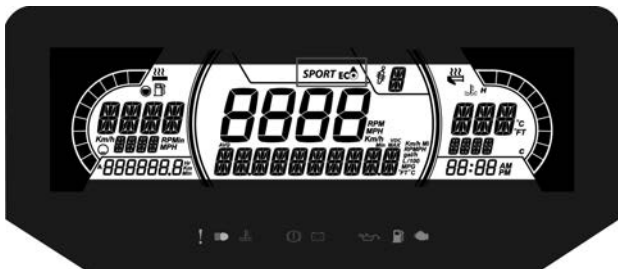

The driving mode display indicates the selected mode of operation:

- SPORT
- ECO
- STANDARD

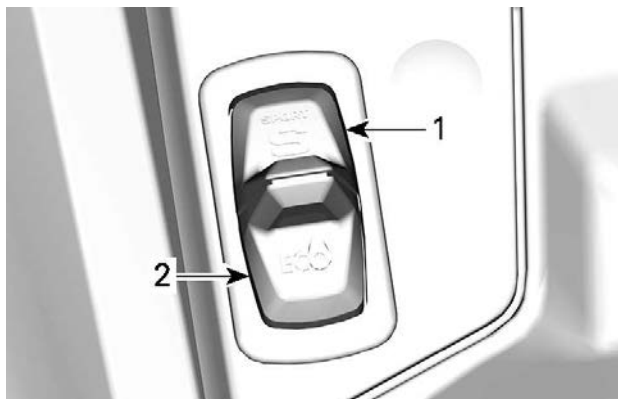
**NOTE:**

When in STANDARD mode, no information is displayed.

A message of the selected mode will be displayed on the lower display at activation and deactivation as follow:

DRIVING MODE	MESSAGE AT ACTIVATION	MESSAGE AT DEACTIVATION
Sport	Sport	Sport OFF
Eco	Eco	Eco OFF









Warning Lamps and Indicators

The following indicator lamps will alert you to a vehicle condition that may become serious. Some lamps will illuminate when starting the vehicle to make sure they work. If any lamps remain on after starting the vehicle, refer to the respective system warning lamp for further information.

NOTE:

Some warning indicators appear in the display of the multifunction gauge and function the same as an indicator lamp but do not display when starting the vehicle.

Telltale Lights - Lower Bar

Lights	Description
	ORANGE - Vehicle malfunction
	BLUE - The high beam are selected
	RED - The engine temperature is too high.
	RED - Parking brake is engaged or malfunction of the brake system
	RED - The battery voltage too low or problem with the electrical system
	RED - Low engine oil pressure (if applicable)
	ORANGE - Low fuel level
	<p>ORANGE</p> <p>Turn on: Malfunction of the vehicle emissions control system</p> <p>Blink: Engine problems, the limp home mode is activated. Have the vehicle serviced immediately.</p>

Icons and Indicators - Multifunction Display

Icons and Indicators	
SPORT	Denotes SPORT mode is selected.
	Denotes ECO mode is selected.

Settings

Setup

Using MENU button, select **SETTINGS** and hold to enter setting menu. Various options are available such as swapping the SPEED and RPM in the Central Display.

Unit Selection

This multifunction gauge is factory preset in metric units but it is possible to change it to imperial units.

Using MENU button, select **UNITS** and hold button to change units.

Setting Clock

Using MENU button, select **CLOCK** and hold to change units.

1. Press MENU button to select clock display.
2. Push and hold MENU button for 1 second.
3. Press MENU button to select 12:00 AM PM or 24:00 time base.
4. Push and hold MENU button or OK button to acknowledge selection.
5. Press MENU button to change hours (hours flash).
6. Push and hold MENU button or OK button to acknowledge hour selection
7. Push MENU button to switch to minutes (minutes flash).
8. Press MENU button to change minutes.

Setting Language

The gauge display language can be changed. Refer to an authorized BRP snowmobile dealer for language availability and to setup the gauge to your preference.

FUEL

Fuel Requirements

NOTICE

Always use fresh gasoline. Gasoline will oxidize; the result is loss of octane, volatile compounds, and the production of gum and varnish deposits which can damage the fuel system.

Alcohol fuel blending varies by country and region. Your vehicle has been designed to operate using the recommended fuels, however, be aware of the following:

- Use of fuel containing alcohol above the percentage specified by government regulations is not recommended and can result in the following problems in the fuel system components:
 - Starting and operating difficulties.
 - Deterioration of rubber or plastic parts.
 - Corrosion of metal parts.
 - Damage to internal engine parts.
- Inspect frequently for the presence of fuel leaks or other fuel system abnormalities if you suspect the presence of alcohol in gasoline exceeds the current government regulations.
- Alcohol blended fuels attract and hold moisture which may lead to fuel phase separation and can result in engine performance problems or engine damage.

Recommended Fuel

Use unleaded gasoline containing MAXIMUM 10% ethanol. The gasoline must have the following minimum octane requirements:

Fuel type	Engine	Minimum octane rating
Fuel with NO ethanol	600 ACE 900 ACE	87 AKI (RON+MON)/2 92 RON
	900 ACE Turbo 900 ACE Turbo R	91 AKI (RON+MON)/2 95 RON
Fuel which may contain up to 10% MAX ethanol	600 ACE 900 ACE 900 ACE Turbo 900 ACE Turbo R	91 AKI (RON+MON)/2 95 RON 

NOTICE

Never experiment with other fuels. Engine or fuel system damages may occur with the use of an inadequate fuel.

NOTICE

Do NOT use fuel from fuel pumps labeled E85.

Use of fuel labeled E15 is prohibited by U.S. EPA Regulations.

Fueling Procedure **WARNING**

Always stop engine before refueling.

 **WARNING**

Fuel is flammable and explosive under certain conditions.
Never use an open flame to check fuel level.
Never smoke or allow flame or spark in vicinity.
Always work in a well-ventilated area.

NOTE:

Do not sit or lean on seat when fuel tank cap is not properly installed.

1. Stop engine.
2. Have operator and passenger get off vehicle.

 **WARNING**

Do not allow anyone seated on the vehicle while fueling.

3. Unscrew slowly the fuel reservoir cap counterclockwise to stabilize pressure before removing it.

NOTE:

A short whistling sound is normal.

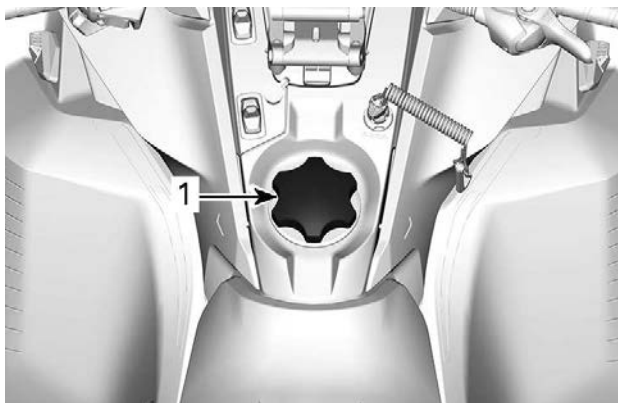

TYPICAL

1. Fuel tank cap

4. Insert the spout into the filler neck.
5. Pour fuel slowly so that air can escape from the tank and prevent fuel flow back. Be careful not to spill fuel.
6. Stop filling when the fuel reaches the bottom of filler neck. **Do not overfill.**

! WARNING

Never top up the fuel tank before placing the vehicle in a warm area. As temperature increases, fuel expands and may overflow.

7. Fully tighten fuel reservoir cap clockwise.

! WARNING

Always wipe off any small fuel spillage from the vehicle. If a major spillage occurs, remove side panels to remove fuel vapors from engine compartment before starting.

NOTE:

Do not sit or lean on seat when fuel tank cap is not properly installed.

ENGINE OIL

Recommended Oil

Rotax® engines were developed and validated using the XPS™ oil. BRP recommends the use of its XPS engine oil or an equivalent at all time. Do not add any oil additives to the recommended engine oil. Damages caused by the use of an oil not suitable for the engine or by adding of an oil additives may not be covered by the BRP Limited Warranty.

XPS RECOMMENDED Engine Oil
4T 0W40 Synthetic oil
IF THE RECOMMENDED XPS ENGINE OIL IS NOT AVAILABLE
Use a 0W40 4-stroke SAE synthetic engine oil meeting or exceeding the following lubricant industry specifications. Always check the API service label certification on the oil container, it must contain at least the indicated standard. – API service classification SN

BREAK-IN PERIOD

Operation During Break-In

Engine

During the break-in period:

- Avoid prolonged full throttle operation.
- Avoid sustained accelerations.
- Avoid prolonged cruising speeds.
- Avoid engine overheating.

However, brief accelerations and speed variations contribute to a good break-in.

During a predetermined period, the engine management system controls some engine parameters.

The duration is based on fuel volume. It will take approximately two fuel tanks to complete the break-in.

During this period:

- The engine performance and behavior will not be optimal.
- The fuel and oil consumption will be higher.

Drive Belt

A new drive belt requires a break in period of 50 km (30 mi).

During the break-in period:

- Avoid strong acceleration and deceleration.
- Avoid pulling a load.
- Avoid high speed cruising.

If the vehicle creeps, lower the drive belt height from the preliminary setting. Refer to *Drive Belt* in *maintenance procedure*.

BASIC PROCEDURES

Engine Starting Procedure

Procedure

1. Apply parking brake.
2. Recheck throttle control lever operation.
3. Put your helmet on.
4. Ensure that the tether cord cap is installed on the engine cut-off switch and that the cord is attached to your clothing eyelet.
5. Ensure that the emergency engine stop switch is in the ON position (up).



WARNING

Never depress throttle while starting engine.

6. Release parking brake.

NOTE:

For an initial cold start, do not release parking brake. Perform the *vehicle warm-up* procedure as explained below.

7. Depress the START button to engage the electric starter and start the engine. Release button immediately when engine has started.

NOTICE

Do not engage electric starter for more than 10 seconds at a time. A rest period should be observed between the cranking cycles to allow electric starter to cool down.

Emergency Starting

Do not attempt any emergency starting procedure. Have the battery charged or replaced.

Vehicle Warm-Up

Before every ride, vehicle has to be warmed up as follows.

1. Start engine as explained in *ENGINE STARTING PROCEDURE (PAGE 179) ENGINE STARTING PROCEDURE* above.
2. Allow engine to warm up one or two minutes at idle speed.

NOTE:

Engine will shut down after approximately 12 minutes of idling.

3. Disengage parking brake.
4. Apply throttle until drive pulley engages. Drive at low speed the first two or three minutes.

NOTICE

If vehicle does not move when throttle is applied, stop engine, remove tether cord cap from the engine cut-off switch, then do the following.

- Check if skis are stuck on the ground. Lift one ski at a time by the handle, then put it down.
- Check if track is stuck on the ground. Lift rear of snowmobile enough to clear track from the ground, then drop.
- Check rear suspension for hard snow or ice accumulation that could interfere with track rotation. Clean the area.
- Validate that transmission is engaged (not in neutral).

CAUTION

Beware of injuries by using proper lifting techniques, notably using your legs force. Do not attempt to lift the rear of vehicle if it is above your limits.

WARNING

Make sure tether cord cap is removed before standing in front the vehicle, getting close to the track or rear suspension components.

NOTE:

Warm-up is electronically controlled. During this period (up to 10 minutes depending on ambient temperature), engine RPM is limited.

Shifting in High or Low range

This transmission is designed to accept shifting while moving. However, shifting while the engine is under heavy load is not recommended.

NOTICE

Shifting at a speed faster than 30 km/h (19 MPH) may cause serious damage to the gearbox.

High Range

This position selects the high speed range of the gearbox. It is the normal driving speed range. It allows the vehicle to reach its maximum speed.

Low Range

This position selects the low speed range of the gearbox. It allows the vehicle to move slowly with maximum engine torque.

Low range should be used whenever:

- Pulling a cargo carrier or accessory
- Hauling a load
- Crossing obstacles
- Climbing onto trailer
- Hill climbing

It is also recommended to use low range if driving for prolonged periods at speeds under 24 km/h (15 MPH).

NOTICE

Use the low speed range to pull a cargo carrier, carry heavy cargo, go over obstacles or drive uphill and downhill.

Shifting in Reverse

1. Bring vehicle to a complete stop.
2. Apply and hold brake. Remain seated, refer to *Rider Position (Reverse Operation)* in *Riding the vehicle* for posture information.
3. With engine at idle speed, select reverse (R) gear using the reverse lever or Start / RER button.

Models with Reverse Lever

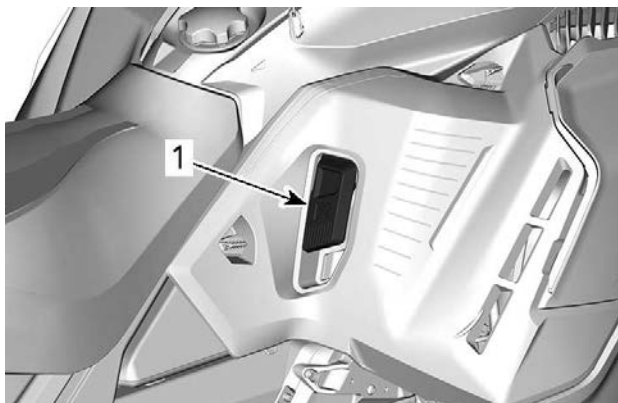

TYPICAL

1. Reverse lever

Models with Start / RER button

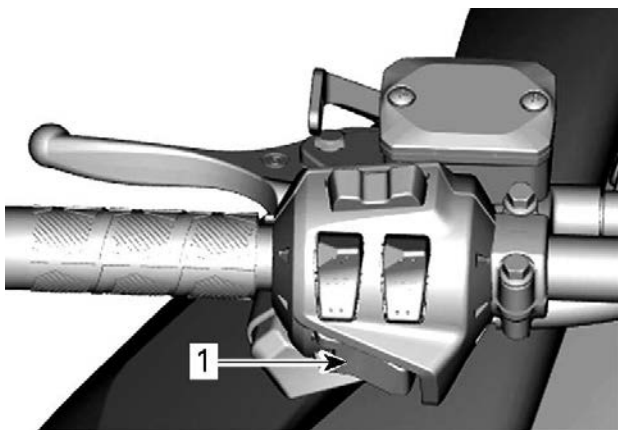

1. Start / RER button

4. Wait until reverse beeper sounds, then gently depress throttle lever.

 **WARNING**

The reverse speed is not limited. Always proceed with caution as fast reverse could result in loss of vehicle stability. Come to complete stop before activating the reverse. Always remain seated and apply the brake before shifting. Ensure the path behind is clear of obstacles or bystanders before proceeding.

Shifting in Forward from Reverse

1. Bring vehicle to a complete stop.
2. Apply and hold brake.
3. Press and release the RER button or reverse lever.
4. Apply throttle slowly and evenly. Allow drive pulley to engage then accelerate carefully.

Shutting Off the Engine

Release throttle lever and wait until engine has returned to idle speed.

Shut off the engine using either the emergency engine stop switch or by pulling off the tether cord cap from the engine cut-off switch.

 **WARNING**

Always remove the tether cord cap from engine cut-off switch when vehicle is not in operation in order to prevent accidental engine starting or to avoid unauthorized use by children or others or theft.

RIDING CONDITIONS AND YOUR SNOWMOBILE

Altitude

At factory, your snowmobile was calibrated to be used within an altitude range (relative to sea level).

A new snowmobile has a tag attached to the handlebar indicating its calibration. Refer to *Safety Information on Vehicle*.

If for any reason you don't know your snowmobile calibration, contact an authorized BRP snowmobile dealer.

If your snowmobile is to be used at an altitude outside the specified range, have it calibrated accordingly by an authorized BRP snowmobile dealer.

NOTICE

An inappropriate altitude calibration would decrease performance and may cause serious damage to the snowmobile.

Temperature

The engine management of these engines provides the optimum air/fuel ratio for all temperatures.

Hard Packed Snow

All models covered in this guide which are equipped with a minimum track profile of 44 mm (1.75 in) are built for deep snow conditions and should never be used during a prolonged period of time in marginal or hard packed snow conditions.

In the event you have to ride in these types of conditions:

- Avoid exceeding a speed of 70 km/h (45 mph) in all conditions
- Avoid hard acceleration (over 75% of throttle)
- Ice scratchers should be applied
- Engine temperature should not exceed 75% on the temperature gauge.

NOTICE

Running these types of tracks at high speed on a trail, on hard packed surfaces or on ice puts more stress on the lugs, which tends to heat up as a result. It also could drastically reduce the life of specific wear parts. To avoid potential degradation, delamination or damages to the track and wear parts, reduce your speed and minimize the distance that is being ridden on these types of surfaces.

Vehicles Equipped with Ice Scratchers

Ice scratchers are equipped on the vehicle to increase engine cooling efficiency, to lubricate and to cool track clips and sliders. They must be used whenever on ice, hard packed snow, or any conditions that do not lift enough snow particles into the rear suspension and the tunnel.

NOTICE

Although it is not recommended to ride a snowmobile equipped with a high lug profile track on trails or hard packed snow conditions, it is highly suggested to combine idler wheels and ice scratchers on a vehicle used in these conditions.

IMPORTANT

Ridding in these trail conditions puts the reliability of the track and its warranty at risk

If equipped with the following track profile heights, never exceed the recommended sustained vehicle speeds listed.

Track Profile Height	Maximum Sustained Speed
57 mm (2.25 in) 60 mm (2.36 in)	110 km/h (70 MPH)
64 mm (2.52 in) 75 mm (3 in)	95 km/h (60 MPH)

TUNE YOUR RIDE

Snowmobile handling and comfort depend upon multiple adjustments.

WARNING

Suspension adjustment could affect vehicle handling. Always take time to familiarize yourself with the vehicle's behavior after any suspension adjustment have been made. Always adjust LH and RH suspension components to the same setting.

Choice of suspension adjustments vary with carrying load, operator's weight, personal preference, riding speed and field condition.

NOTE:

Some adjustments may not apply to your snowmobile.

WARNING

Before proceeding with any suspension adjustment, remember:

- **Park in a safe place.**
- **Remove the tether cord cap from the engine cut-off switch.**
- **Use appropriate lifting device or have assistance to share lifting stress. If a lifting device is not used, use proper lifting techniques, notably using your legs force.**
- **Do not attempt to lift the front or rear of vehicle if it is above your limits.**
- **Support front of vehicle off the ground with a suitable device before adjusting suspension.**
- **Support rear of vehicle off the ground with a wide-base snowmobile stand with a rear deflector panel.**
- **Make sure support device is stable and secure.**

The best way to set up the suspension is to customize each adjustment one at a time. Various adjustments are interrelated. It may be necessary to readjust center spring after adjusting front springs for instance. Test run the snowmobile under the same conditions; trail, speed, snow, operator riding position, etc. Proceed methodically until you are satisfied.

Following are guidelines to fine-tune suspension. Use suspension adjustment tool provided in the tool kit.

Front Suspension Adjustments

Ski Stance

Skis can be set to three different widths.

To obtain the different widths, place the spacers:

- Inside the skis leg (narrowest ski stance setting: easiest to initiate turn on sidehills), or
- Outside the skis leg (widest ski stance setting: most stable on corners), or
- On each side (central setting: best steering accuracy on deep snow).

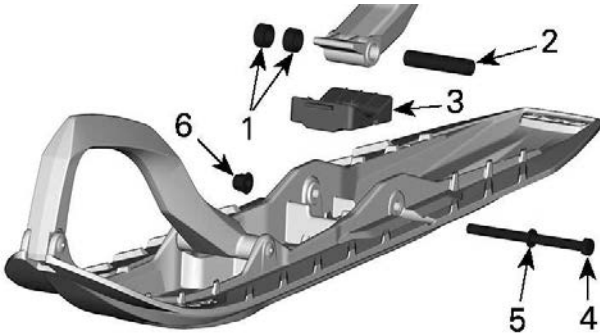

1. Spacers
2. Axle
3. Stopper
4. Screw
5. Washer
6. Nut

TIGHTENING TORQUE

Ski nut	$48 \pm 6 \text{ Nm}$ ($35 \pm 4 \text{ lbf-ft}$)
---------	--------------------------------------------------------

Front Springs

Front spring preload has an effect on front suspension firmness.

Front spring preload also has an effect on the steering behavior.

Action	Result
Increasing preload	Firmer front suspension

Action	Result
	Higher front end
	More precise steering
	More bump absorption capability
Decreasing preload	Softer front suspension
	Lower front end
	Lighter steering
	Less bump absorption capability

⚠ WARNING

Adjust both springs to the same preload. Uneven adjustment can cause poor handling and loss of stability, and/or control, and increase the risk of an accident.

Cam Type Adjuster

Using the suspension adjustment tool provided in the tool kit, turn the cam to increase or decrease the spring preload.

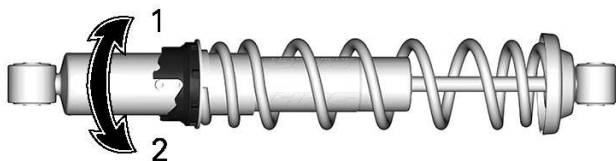

1. Increase preload
2. Decrease preload

Ring Adjuster – Type 1

Grab and turn the ring and the spring to increase or decrease the spring preload.

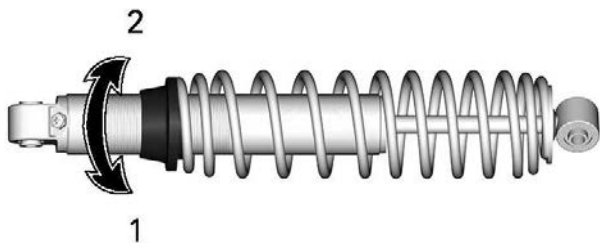

1. Increase preload
2. Decrease preload

Ring Adjuster – Type 2

Grab and turn the ring and the spring to increase or decrease the spring preload.

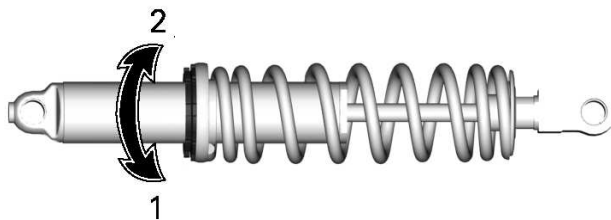

1. Increase preload
2. Decrease preload

Rear Suspension Adjustments

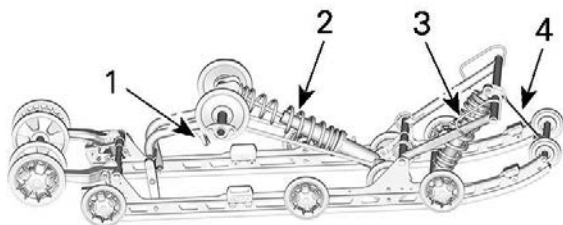

EASYRIDE - ADJUSTABLE COMPONENTS

1. Easy Adjust Handle (if equipped)
2. Rear spring
3. Center spring
4. Stopper strap

NOTICE

Whenever adjusting rear suspension, check track tension and adjust if necessary.

Stopper Strap – EasyRide Suspension

Stopper strap length has an effect on the amount of weight the center spring has to carry especially during acceleration, therefore on the front end uplift.

Stopper strap length also has an effect on center spring travel.

NOTICE

Whenever stopper strap length is changed, track tension must be checked.

NOTE:

Stopper strap can be set to position 1, 2 or 3. Smaller numbers correspond to a longer strap setting.

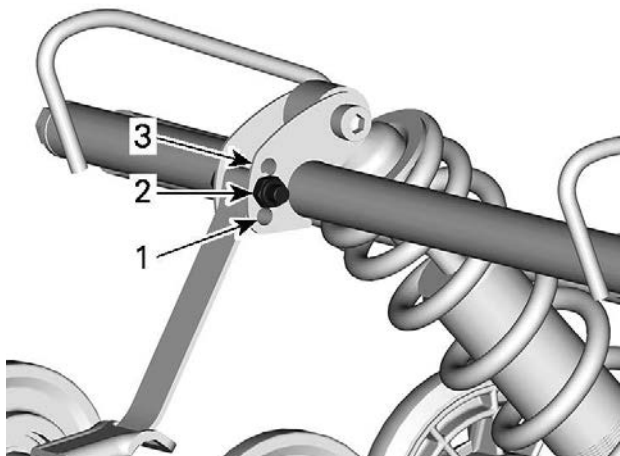

STOPPER STRAP POSITIONS

1. *Position 1 (longest)*
2. *Position 2*
3. *Position 3 (shortest)*

When operating the snowmobile in deep snow or hill climbing, it may be necessary to vary stopper strap length and/or riding position, to change the angle at which the track rides on the snow. Operator's familiarity with the various adjustments as well as snow conditions will dictate the most efficient combination.

Generally, a longer stopper strap setting gives better performance on a flat landscape and a shorter setting will improve handling in steep hill climbing and deep snow conditions.

Stopper Strap Setting	
Position	Use
1	Boon docking: <ul style="list-style-type: none"> - Better bump absorption - Lighter and easier handling on flat landscape.
2	Standard setting: Best overall setting (general use)
3	Hill climb: <ul style="list-style-type: none"> - Better track attack angle for hill climbing - Less transfer - Lower ride height

Center Spring

Center spring preload has an effect on steering effort, handling and bump absorption.

Also, since center spring preload adjustment puts more or less pressure on the front of the track, it has an effect on the performance in deep snow.

Action	Result
Increasing preload	Lighter steering
	More bump absorption capability
	Better deep snow starts
	Better deep snow performance and handling
Decreasing preload	Heavier steering
	Less bump absorption capability
	Better trail handling

Cam Type Adjuster

Using the suspension adjustment tool provided in the tool kit, turn the cam to increase or decrease the spring preload.

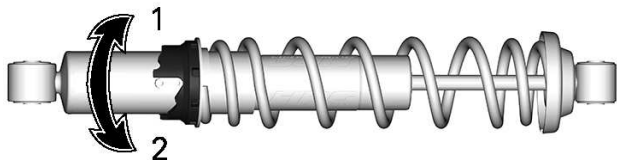

1. Increase preload
2. Decrease preload

Ring Type Adjuster

Grab and turn the ring and the spring to increase or decrease the spring preload.

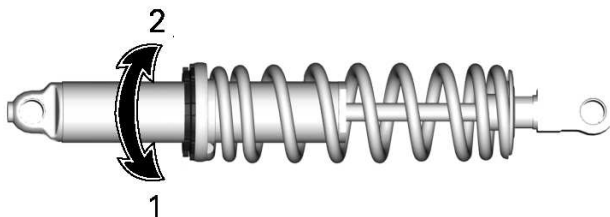

1. Increase preload
2. Decrease preload

Rear Spring

Rear spring preload has an effect on comfort, ride height and load compensation.

Also, adjusting rear spring preload shifts more or less weight to the snowmobile front end. As a result, more or less weight is applied to the skis. This has an effect on performance in deep snow, steering effort and handling.

Slight suspension bottoming occurring under the worst riding conditions indicates a good choice of spring preload.

Action	Result
Increasing preload	Firmer rear suspension
	Higher rear end
	More bump absorption capability
	Heavier steering
Decreasing preload	Softer rear suspension
	Lower rear end
	Less bump absorption capability
	Lighter steering
	Better deep snow performance and handling

Refer to the following to determine if preload is correct.

- A = Suspension fully extended
- B = Suspension has collapsed with operator, passenger(s) and load added
- C = Distance between dimension "A" and "B", see table below

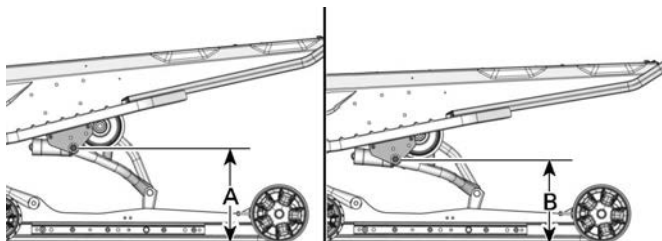

TYPICAL - DISTANCE BETWEEN GROUND AND UPPER REAR ARM PIVOT

C	What to do
90 to 100 mm (3.6 to 4 in)	No adjustment required
More than 100 mm (4 in)	Adjusted too soft. Increase preload
Less than 90 mm (3.6 in)	Adjusted too firm. Decrease preload

NOTE:

If the specification is unattainable with the original springs, visit an authorized BRP snowmobile dealer for other available springs.

Using the suspension adjustment tool provided in the tool kit, unscrew the lock ring and turn the adjustment ring to increase or decrease the spring preload.

Tighten the lock ring when the adjustment is done.

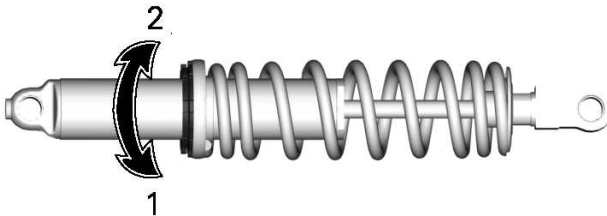

1. Increase preload
2. Decrease preload

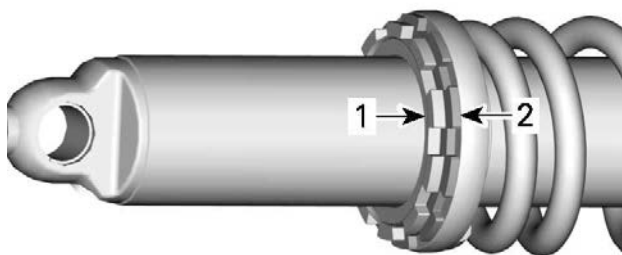

1. Locking ring
2. Adjustment ring

Load Capacity Adjustment (If Equipped)

Some EasyRide suspension have an additional adjustment for the rear suspension load capacity.

NOTICE

The adjustment must always be tightened all the way to either end of the adjustment. Do not leave the adjustment in between of these positions, damage can occur.

To adjust proceed as follows:

Hard Setting

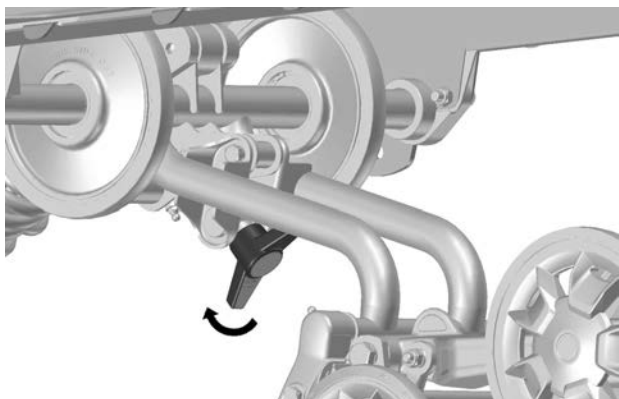

TURN HANDLE ALL THE WAY CLOCKWISE - HARDER SUSPENSION

Turn handle clockwise completely for harder suspension.

NOTE:

Ensure the limiter is touching the rear arm bracket.

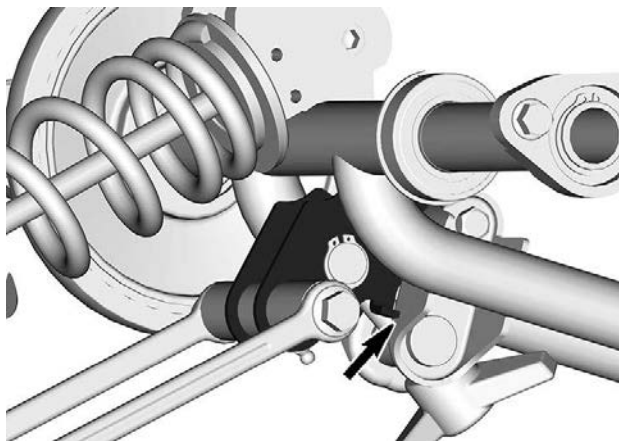

Soft Setting

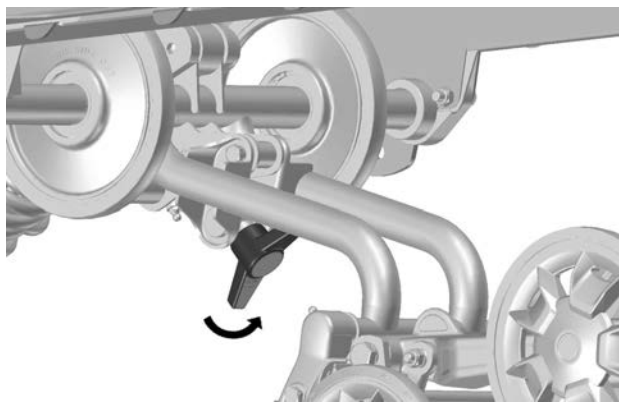

TURN HANDLE ALL THE WAY COUNTERCLOCKWISE - SOFTER SUSPENSION

Turn handle counterclockwise completely for softer suspension. (Factory setting)

NOTE:

Ensure the limiter is touching the rear arm tube.

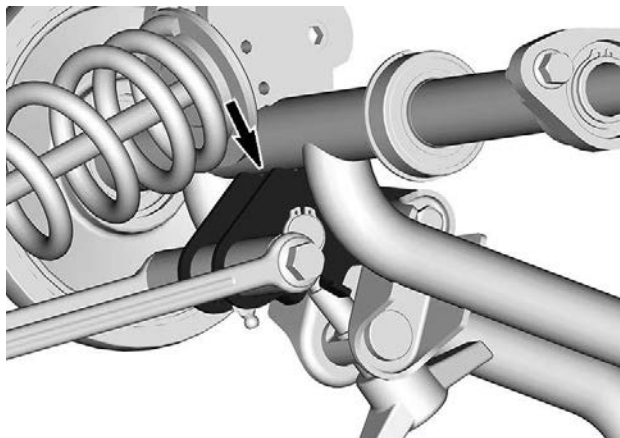

Adjustment chart

	Comfort (1-up)	Comfort (2-up)	Carrying cargo	Hauling heavy loads
Soft Setting	X			X
Hard Setting		X	X	

Adjustment Tips According to Vehicle Behavior

Problem	Corrective Measures
Front suspension darting	Check ski alignment. – Reduce front suspension spring preload. – Increase center spring preload. – Reduce rear spring preload.
Steering feels too heavy at steady speeds	– Reduce front suspension spring preload. – Increase center spring preload.
Steering feels too heavy during acceleration	– Reduce rear spring preload. – Lengthen limiter strap.
Too much ski lift during cornering or acceleration	– Shorten limiter strap. – Increase rear spring preload.
Rear of snowmobile seems too stiff	– Reduce rear spring preload.
Rear of snowmobile seems too soft	– Increase rear spring preload.
Rear suspension is frequently bottoming	– Increase rear spring preload. – Increase center spring preload. – Lengthen limiter strap.
Snowmobile seems to pivot around its center	– Reduce center spring preload. – Increase rear spring preload. – Increase front suspension spring preload. – Shorten limiter strap.
Track spins too much at start	– Lengthen limiter strap. – Reduce rear spring preload. – Increase center spring preload.

MAINTENANCE

MAINTENANCE SCHEDULE

Maintenance is very important to keep your vehicle in safe operating condition. The vehicle should be serviced as per the maintenance schedule.

Proper maintenance is the owner's responsibility. A warranty claim may be denied if, among other things, the owner or operator caused the problem through improper maintenance or use.

Perform periodic checks and follow the maintenance schedule. **The maintenance schedule does not exempt the pre-ride inspection.**

 **WARNING**

Failure to properly maintain the vehicle according to the maintenance schedule and procedures can make it unsafe to operate.

EPA Regulation - Canadian and USA Vehicles

A repair shop or person of the owner's choosing may maintain, replace, or repair emission control devices and systems. These instructions do not require components or service by BRP or authorized BRP snowmobile dealers.

Although an authorized BRP snowmobile dealer has an in-depth technical knowledge and tools to service your vehicle, the emission-related warranty is not conditioned on the use of an authorized BRP snowmobile dealer or any other establishment with which BRP has a commercial relationship.

Proper maintenance is the owner's responsibility. A warranty claim may be denied if, among other things, the owner or operator caused the problem through improper maintenance or use.

For emission-related warranty claims, BRP is limiting the diagnosis and repair of emission-related parts to the authorized BRP snowmobile dealers. For more information, please refer to the *US EPA Emissions PERFORMANCE WARRANTY* contained in the *warranty* section.

You must follow the instructions for fuel requirements in the fueling section of this manual. Even if gasoline containing greater than ten volume percent ethanol is readily available, the US EPA issued a prohibition against the use of gasoline containing greater than 10 vol% ethanol that applies to this vehicle. The use of gasoline containing greater than 10 vol% ethanol with this engine may harm the emission control system.

Trail/ Crossover/ Utility Usage

Whether your vehicle is a Trail, Crossover, or Utility model, these types of usage require maintenance tasks to be performed between the regular yearly intervals. These are identified as A+ in the chart below.

If you regularly ride in **trails, explore the countryside, or work** with your snowmobile, follow the A+ Trail / Crossover / Utility interval and perform the tasks outlined in the chart below.

Extreme Cold Condition

An engine that is frequently operated at or below an ambient temperature of $-25\text{ }^{\circ}\text{C}$ ($-13\text{ }^{\circ}\text{F}$) will require an increase in service and maintenance schedule.

Any combustion engine operated at these low ambient temperature will collect an increased amount of condensation at every startup/warm-up.

Since the engine is not reaching operating temperatures for extended periods of time, the oil is starting to be strongly diluted with water and gas residue (more water content).

An engine needs to reach operating temperature, in order to be able to evaporate condensate out of the oil.

If daily usage (work or leisure driving cycle) is similar to those mentioned below, BRP strongly recommends changing the oil at least once a month.

Parameters of an increase in service and maintenance schedule:

- Engine not reaching the proper operating temperature during normal daily usage
- Multiple starts and stops without reaching operating temperature
- Short idle periods
- Low RPM driving cycle in short distances without reaching operating temperature.

NOTE:

BRP strongly recommends the installation of a block heater to help warm up the liquids, this will also help to extend the oil lifetime.

Maintenance Schedule

Make sure to perform proper maintenance at recommended intervals as indicated in the tables.

The maintenance chart indicates the items needing to be addressed based on 2 criteria, whichever happens first:

- Calendar time
- Odometer reading.

Your driving habits determines the factors you shall adhere too. For example:

- Someone who uses their vehicle every other weekend trail riding with friends would most likely follow the **odometer reading** to determine the frequency of his maintenance.
- Someone who uses their vehicle seldomly over the year or only on a few occasions would follow the **calendar time** to determine the frequency of his maintenance.

IMPORTANT: The following tables show the appropriate maintenance application for the first 3 years. For subsequent years, repeat the same pattern alternatively.

Maintenance Overview		
Calendar Time	Odometer	Trail/ Cross Over/ Utility
Every Month	1500 km (1000 mi)	A+
1 Year	3000 km (2000 mi)	A
Every Month	4500 km (3000 mi)	A+
2 Years	6000 km (4000 mi)	A and B
Every Month	7500 km (5000 mi)	A+

600 ACE/ 900 ACE Engines

TRAIL / CROSSOVER / UTILITY	A+	A	B
A = Adjust C = Clean I = Inspect L = Lubricate R = Replace T = Torque	Every month or 1500 km (1000 mi)	Every year or 3000 km (2000 mi)	Every 2 years or 6000 km (4000 mi)
Air and Fuel Delivery			
Fuel components (fuel cap, hoses, clamps and tank fixation) and function		I	
In-line fuel filter		R Every 5 years	
Body and Chassis			
Body panels and hardware		I, T	
Pivots, latches, hinges and key barrels		L	
Engine and Cooling			
Engine cooling components (coolant concentration, coolant level, hose condition, clamps, leaks)		I, A	
Engine oil and oil filter		R	
Engine seals and gaskets		I	
Spark plugs		R Every 3 years	

TRAIL / CROSSOVER / UTILITY	A+	A	B
A = Adjust C = Clean I = Inspect L = Lubricate R = Replace T = Torque	Every month or 1500 km (1000 mi)	Every year or 3000 km (2000 mi)	Every 2 years or 6000 km (4000 mi)
		or 10 000 km (6000 mi)	
Engine coolant		R Every 5 years	
Exhaust and Emissions			
Exhaust components (gaskets, pipes, muffler condition, leaks)		I	
Exhaust manifold		T	
Brake			
Brake components and function		I, L	
Brake fluid			R Every 2 years
Drive			
Chaincase drive chain tension	A	A	
Gearbox / chaincase oil level	I	I	
Track alignment and tension	A	I, A	

TRAIL / CROSSOVER / UTILITY	A+	A	B
A = Adjust C = Clean I = Inspect L = Lubricate R = Replace T = Torque	Every month or 1500 km (1000 mi)	Every year or 3000 km (2000 mi)	Every 2 years or 6000 km (4000 mi)
Gearbox / chaincase oil			R
Continuously Variable Transmission (CVT)			
CVT components and function		I, C, L	
CVT drive belt condition	I		
CVT drive belt tension	A	A	
Drive pulley retaining screw		T	
Electrical			
Battery connections and condition		I	
Electrical harness routing		I	
Headlight aim		A	
Modules and applicable software updates		I	
Operation of control switches and lighting		I	
Steering and Controls			
Ski runners	I	I	
Gearbox position lever operation		I, A	
Steering alignment		I, A	

TRAIL / CROSSOVER / UTILITY	A+	A	B
A = Adjust C = Clean I = Inspect L = Lubricate R = Replace T = Torque	Every month or 1500 km (1000 mi)	Every year or 3000 km (2000 mi)	Every 2 years or 6000 km (4000 mi)
Steering components and function		I	
Throttle cable		A	
Throttle operation		I	
Suspension			
Suspension components and function		I, L	

900 ACE Turbo/ R

TRAIL / CROSSOVER / UTILITY	A+	A	B
A = Adjust C = Clean I = Inspect L = Lubricate R = Replace T = Torque	Every month or 1500 km (1000 mi)	Every year or 3000 km (2000 mi)	Every 2 years or 6000 km (4000 mi)
Air and Fuel Delivery			
Fuel components (fuel cap, hoses, clamps and tank fixation) and function		I	
In-line fuel filter		R Every 5 years	
Body and Chassis			
Body panels and hardware		I, T	
Pivots, latches, hinges and key barrels		L	
Engine and Cooling			
Engine cooling components (coolant concentration, coolant level, hose condition, clamps, leaks)		I, A	
Engine oil and oil filter		R	
Engine seals and gaskets		I	
Spark plugs		R Every 3 years	

TRAIL / CROSSOVER / UTILITY	A+	A	B
A = Adjust C = Clean I = Inspect L = Lubricate R = Replace T = Torque	Every month or 1500 km (1000 mi)	Every year or 3000 km (2000 mi)	Every 2 years or 6000 km (4000 mi)
		or 10 000 km (6000 mi)	
Engine coolant		R Every 5 years	
Exhaust and Emissions			
Exhaust components (gaskets, pipes, muffler condition, leaks)		I	
Exhaust manifold		T	
Turbo exhaust gasket		R Every 3 years or 10 000 km (6000 mi)	
Brake			
Brake components and function		I, L	
Brake fluid		R Every 2 years	

TRAIL / CROSSOVER / UTILITY	A+	A	B
A = Adjust C = Clean I = Inspect L = Lubricate R = Replace T = Torque	Every month or 1500 km (1000 mi)	Every year or 3000 km (2000 mi)	Every 2 years or 6000 km (4000 mi)
Drive			
Chaincase drive chain tension	A	A	
Gearbox / chaincase oil level	I	I	
Track alignment and tension	A	I, A	
Gearbox / chaincase oil			R
Continuously Variable Transmission (CVT)			
CVT components and function		I, C, L	
CVT drive belt condition	I		
CVT drive belt tension	A	A	
Drive pulley retaining screw		T	
Electrical			
Battery connections and condition		I	
Electrical harness routing		I	
Headlight aim		A	
Modules and applicable software updates		I	
Operation of control switches and lighting		I	

TRAIL / CROSSOVER / UTILITY	A+	A	B
A = Adjust C = Clean I = Inspect L = Lubricate R = Replace T = Torque	Every month or 1500 km (1000 mi)	Every year or 3000 km (2000 mi)	Every 2 years or 6000 km (4000 mi)
Steering and Controls			
Ski runners	I	I	
Gearbox position lever operation		I, A	
Steering alignment		I, A	
Steering components and function		I	
Throttle cable		A	
Throttle operation		I	
Suspension			
Suspension components and function		I, L	

MAINTENANCE PROCEDURES

This section includes instructions for basic maintenance procedures.

 **WARNING**

Turn off the engine, remove tether cord cap and follow these maintenance procedures when performing maintenance. If you do not follow proper maintenance procedures you can be injured by hot parts, moving parts, electricity, chemicals or other hazards.

 **WARNING**

Should removal of a locking device be required (e.g. lock tabs, self-locking fasteners, etc.) when undergoing disassembly/assembly, always replace with a new one.

Engine Coolant

 **WARNING**

Never open coolant tank cap when engine is hot.

Engine Coolant Level Verification

Open the RH side panel, see *Body and Seat*.

Check coolant level at room temperature. Liquid should be at cold level line of coolant tank.

NOTE:

When checking level at low temperature it may be slightly lower than the mark.

If additional coolant is necessary or if entire system has to be refilled, refer to an authorized BRP snowmobile dealer, repair shop or person of your own choosing.

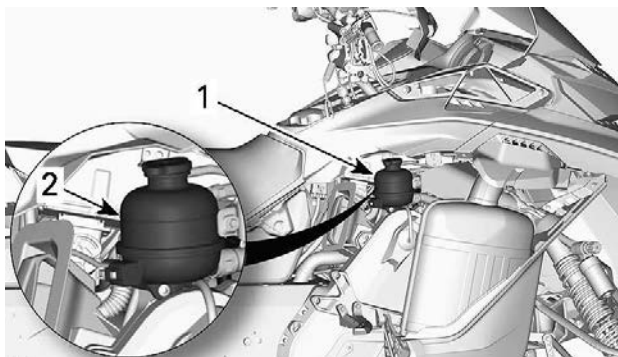

1. Coolant reservoir
2. COLD line

Recommended Engine Coolant

RECOMMENDED COOLANT
XPS Extended life pre-mixed coolant
IF THE RECOMMENDED XPS COOLANT IS NOT AVAILABLE
Distilled water and antifreeze solution (50% distilled water, 50% antifreeze)

NOTICE

Always use ethylene-glycol antifreeze containing corrosion inhibitors specifically for internal combustion aluminum engines.

Engine Oil

Extreme Cold Condition

An engine that is operated in $-25^{\circ}\text{C}/-13^{\circ}\text{F}$ and below environment will require an increase in service and maintenance schedule.

Any combustion engine operated in such a low load and rather cold operating temperature collects an increased amount of condensation at every startup/warm-up.

Since the engine is not reaching operating temperatures for extended periods of time, the oil is starting to be strongly diluted with water and gas residue (more water content).

An engine needs to reach operating temperature, in order to be able to evaporate condensate out of the oil.

If daily usage (work or leisure driving cycle) is similar to those mentioned below, BRP strongly recommends changing the oil at least once a month.

Parameters of an increase in service and maintenance schedule:

- Engine not reaching the proper operating temperature during normal daily usage
- Multiple starts and stops without reaching operating temperature
- Short idle periods
- Low RPM driving cycle in short distances without reaching operating temperature.

NOTE:

BRP strongly recommends the installation of a block heater to help warm up the liquids, this will also help to extend the oil lifetime.

Recommended Oil

Rotax® engines were developed and validated using the XPS™ oil. BRP recommends the use of its XPS engine oil or an equivalent at all time. Do not add any oil additives to the recommended engine oil. Damages caused by the use of an oil not suitable for the engine or by adding of an oil additives may not be covered by the BRP Limited Warranty.

XPS RECOMMENDED Engine Oil
4T 0W40 Synthetic oil
IF THE RECOMMENDED XPS ENGINE OIL IS NOT AVAILABLE
<p>Use a 0W40 4-stroke SAE synthetic engine oil meeting or exceeding the following lubricant industry specifications. Always check the API service label certification on the oil container, it must contain at least the indicated standard.</p> <ul style="list-style-type: none"> - API service classification SN

Verifying the Engine Oil Level

NOTICE

Check level before each ride and refill if necessary. Do not overfill. Operating the engine with an improper level may severely damage engine. Wipe off any spillage.

Place vehicle on a level surface and proceed as follows to check oil level:

1. Start engine and let it reach its normal operating temperature. Engine is at normal temperature when rear radiator gets warm, indicating that the thermostat is open.
2. Let engine run at idle for 30 more seconds.
3. Stop engine.
4. Open the LH side panel. Refer to *Body and Seat*.
5. Remove the drive belt guard, refer to *Drive Belt Guard*.
6. Remove dipstick from the filler tube, then wipe it clean.
7. Completely insert dipstick in the filler tube.
8. Remove dipstick and check the oil level. Oil level should be between the MIN and MAX marks as shown, add if necessary.

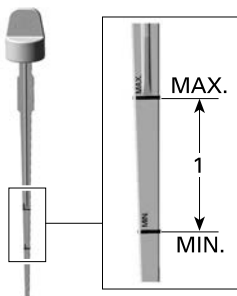

1. Oil level between MIN. and MAX.

⚠ CAUTION

Engine oil can be very hot.

⚠ WARNING

Wipe off any oil spills. Oil is highly flammable when heated.

Replacing the Engine Oil**⚠ CAUTION**

The engine oil can be very hot. Wait until engine oil is warm.

NOTICE

Engine oil and oil filter must be replaced at the same time.

1. Bring engine to its normal operating temperature.
2. Place vehicle on a level surface.
3. Remove the LH side panel.
4. Remove dipstick.

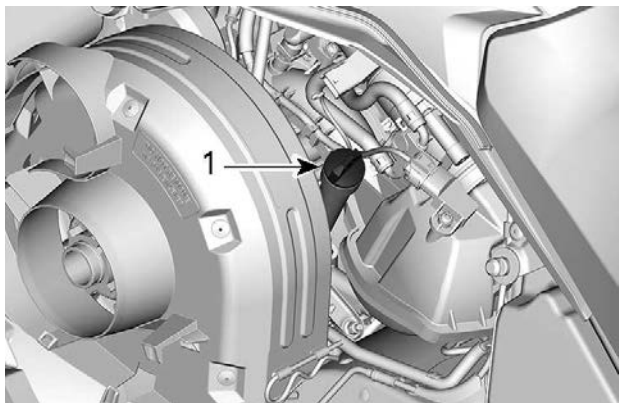
**LH SIDE OF VEHICLE**

1. Oil tank dipstick
5. Remove the *oil filter*. Refer to the procedure in this subsection.
6. From underneath the vehicle, access the drain plug:
 1. Remove one access cover retaining screw and loosen the other.

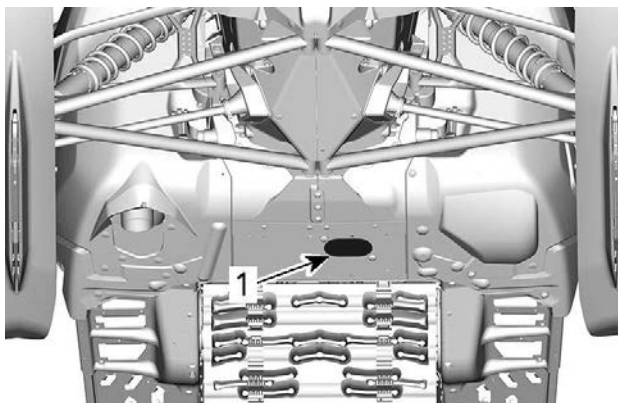

1. Drain plugs access cover

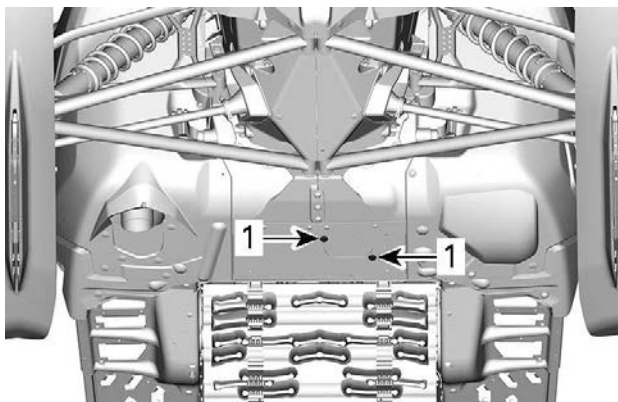

PIVOT THE ACCESS COVER

1. Retaining screws

2. Pivot the access cover to clear the bottom pan opening.

7. Clean drain plug area.

8. Place a drain pan under the bottom pan opening.

9. Remove engine drain plugs in the following order.

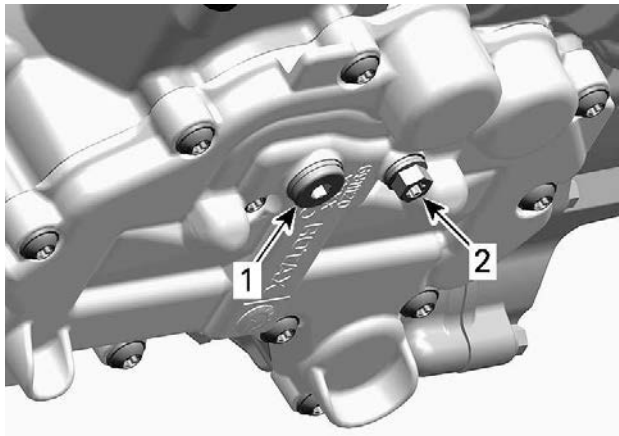

UNDERNEATH THE ENGINE

1. Main drain plug
2. Secondary drain plug

10. Allow oil to drain completely.

11. Install **NEW** sealing washers on oil drain plugs.

NOTICE

Never use a sealing washer a second time. Always replace with a new one.

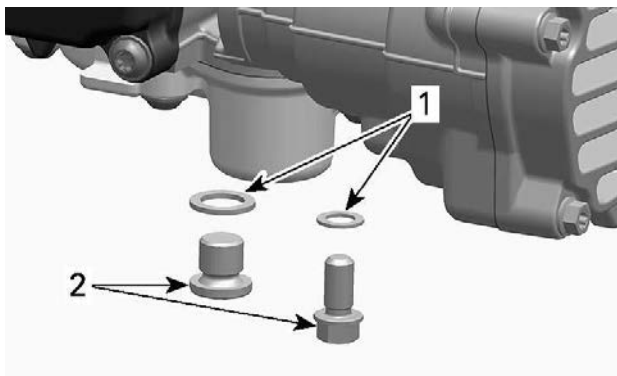

1. Sealing washer
2. Oil drain plug

12. Install drain plugs and tighten to specification.

Tightening Torque	
Drain plugs	15 ± 2 Nm (133 ± 18 lbf-in)

13. Install a new oil filter. Refer to procedure in this subsection.
14. Refill oil tank at the proper level with the recommended oil.

Approximate Engine Oil Capacity (with filter)	
600 ACE	2.1 l (2.22 qt(liq.,US))
900 ACE 900 ACE Turbo 900 ACE Turbo R	3.3 l (3.5 qt(liq.,US))

15. Reinstall dipstick in oil tank and properly tighten it.
16. Start engine and let it idle for a few minutes.
17. Ensure there are no leaks.
18. Stop engine and check oil level as explained in this subsection. Re-fill if necessary.
19. Dispose oil and filter as per your local environmental regulations.

Engine Oil Filter

Engine Oil Filter Replacement

Removing the Oil Filter

1. Remove the RH side panel.
2. Clean oil filter area.
3. Remove:
 - Oil filter cover screws
 - Oil filter cover with O-ring
 - Oil filter.

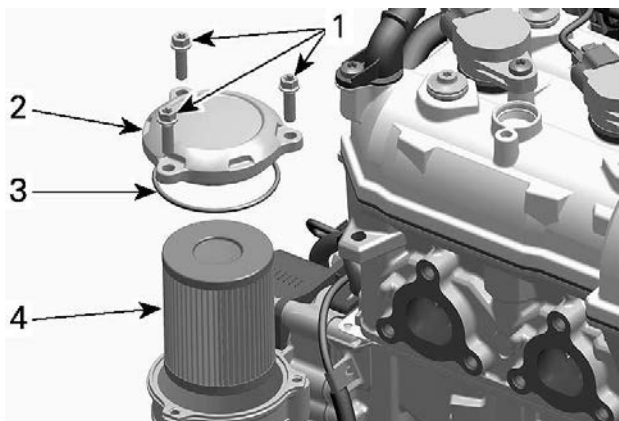

1. Oil filter cover screws
2. Oil filter cover
3. O-ring
4. Oil filter

4. Dispose filter as per your local environmental regulations.

Installing the Oil Filter

1. Check the oil filter inlet and outlet orifices inside oil filter receptacle (integrated part of magneto cover) for dirt and contaminations.

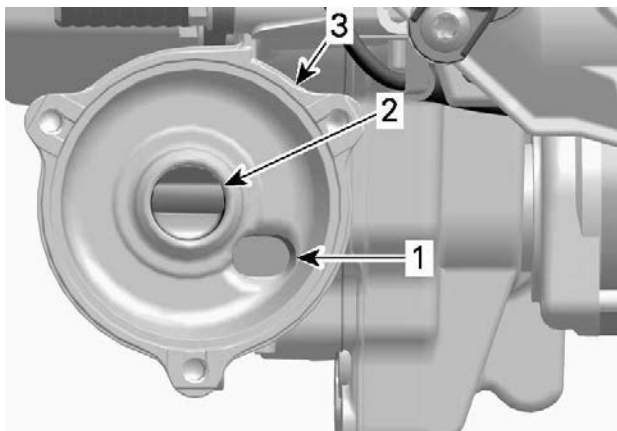

1. Oil inlet orifice from the oil pressure pump
2. Oil outlet orifice to the engine lubrication system
3. Oil filter receptacle

2. Install a new O-ring on oil filter cover.
3. Install the new filter into the cover.
4. Lubricate filter seal and cover O-ring with engine oil.



1. Lubricate with engine oil

NOTICE

Pay attention to avoid pinching the O-ring during filter and cover installation.

5. Install the oil filter cover.
6. Tighten oil filter cover screws to specification.

Tightening Torque	
Oil filter cover screws	10 ± 1 Nm (89 \pm 9 lbf-in)

7. Wipe off any oil spillage on engine.

Exhaust System

Exhaust System Verification

The muffler tail pipe should be centered with the exit hole in the bottom pan. Exhaust system must be free of rust or leaks. Make sure that all parts are securely in place.

Check retaining springs and heat shields condition and replace if necessary.

The exhaust system is designed to reduce noise and to improve the total performance of the engine. Modification may be in violation of local laws.

NOTICE

If any exhaust system component is removed, modified or damaged, severe engine damage may result.

Spark Plugs

Spark plugs inspection or replacement may be performed by an authorized BRP snowmobile dealer, repair shop, or person of your own choosing. Spark plugs inspection or replacement requires an in-depth technical knowledge. Though not required, it is recommended that an authorized BRP snowmobile dealer performs spark plugs inspection or replacement.

Brake Fluid

Brake Fluid Level Verification

NOTICE

Vehicle must be on a level surface before checking any fluid levels.

Check brake fluid (DOT 4) in reservoir for proper level. Add fluid (DOT 4) as required.

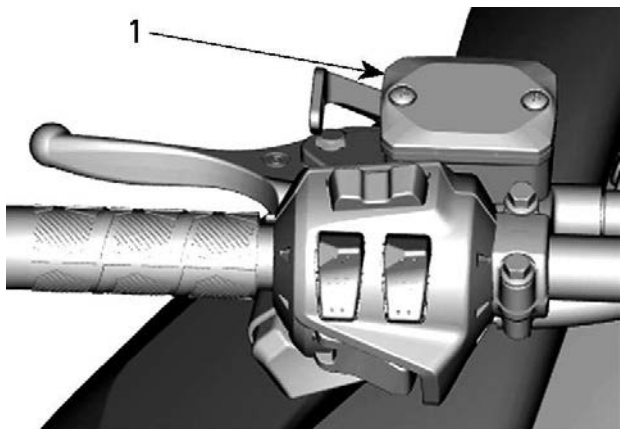

TYPICAL

1. Brake fluid reservoir

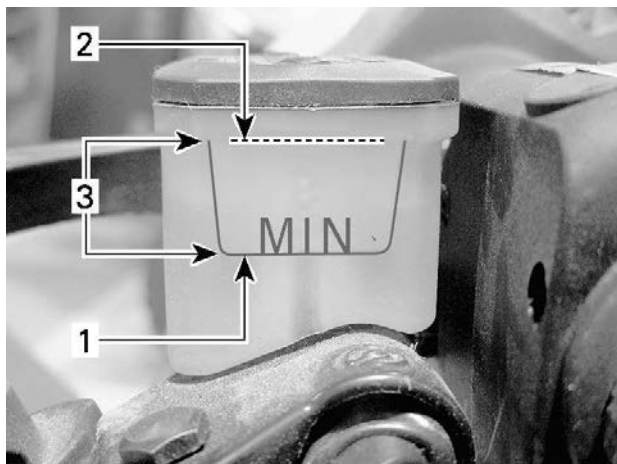

TYPICAL

1. Minimum
2. Maximum
3. Operating range

⚠ CAUTION

Avoid getting brake fluid on skin or eyes - it may cause severe burns. In case of contact with the skin, wash thoroughly. In case of contact with the eyes, immediately rinse with plenty of water for at least 10 minutes and then consult a doctor immediately.

Recommended Brake Fluid

Recommended Brake Fluid
XPS DOT 4 Brake Fluid
Alternative or if not available
DOT 4 Brake Fluid

Use only DOT 4 brake fluid from a sealed container. An opened container may be contaminated or may have absorbed moisture from the air.

 **WARNING**

Use only DOT 4 brake fluid from a sealed container. To avoid serious damage to the braking system, do not use fluids other than the recommended one, nor mix different fluids for topping up.

Chaincase Oil

Recommended Chaincase Oil

Recommended Chaincase Oil
XPS Synthetic chaincase oil
Alternative or if not available
75W140 gear oil that meets the API GL-5 specification

NOTICE

If the recommended XPS chaincase oil is not available, use a 75W140 gear oil that meets the API GL-5 specification. The chaincase of this snowmobile has been developed and validated using the XPS™ Synthetic chaincase oil. BRP strongly recommends the use of its XPS Synthetic chaincase oil at all times. Damages caused by oil which is not suitable for the chaincase will not be covered by the BRP limited warranty.

Verifying the Chaincase Oil Level

With the vehicle on a level surface, check the oil level by removing the check plug.

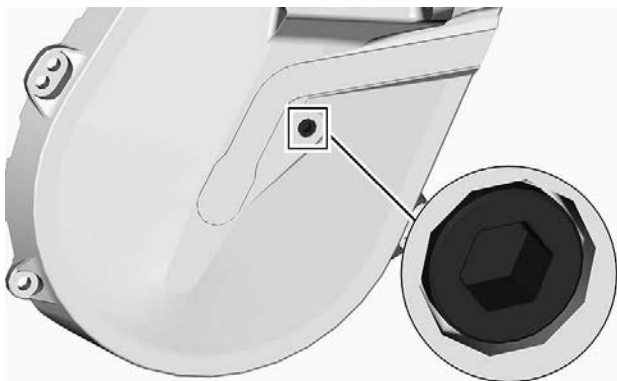

CHECK PLUG

Oil level must reach the threaded hole.

If level is correct, reinstall check plug and tighten to the specified torque.

Tightening Torque	
Check plug	6 ± 1 Nm (53 \pm 9 lbf-in)

If level is insufficient, refer to *Chaincase Filling Procedure*.

Replacing the Chaincase Oil

Draining the Chaincase Oil

1. Place the vehicle on a level surface.
2. Place a drain pan under the chaincase drain plug area.
3. Remove filler cap.
4. Remove the drain plug located at the bottom of the chaincase.

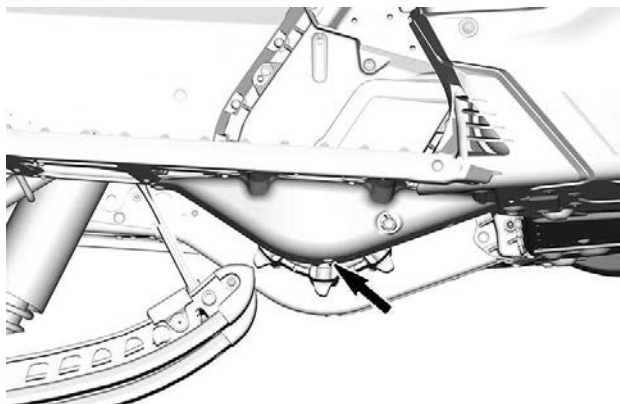

5. Wait a while to allow all oil to drain out of the chaincase.
6. Install drain plug and tighten to specification.

Tightening Torque	
Chaincase drain plug	6 ± 1 Nm (53 ± 9 lbf-in)

Filling the Chaincase

1. Open the RH side panel. Refer to *Equipment*.
2. Remove the check plug.

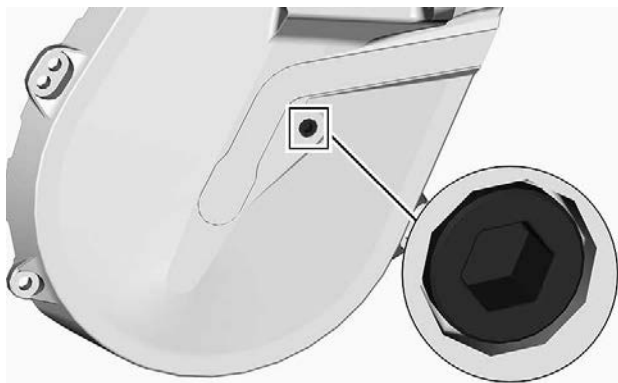

CHECK PLUG

3. Remove the filler cap.

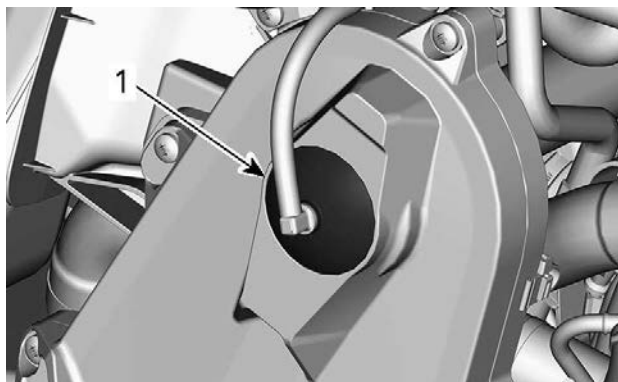

TYPICAL - TOP OF CHAINCASE

1. Filler cap

4. Pour recommended oil in the filler hole until oil comes out by the check plug hole.
5. Reinstall check plug and tighten to specification.

Tightening Torque	
Check plug	6 ± 1 Nm (53 ± 9 lbf-in)

Reinstall the filler cap.

Gearbox Oil

Recommended Gearbox Oil

XPS RECOMMENDED Chaincase Oil
XPS™ Synchronesh Transmission Synthetic Oil
IF THE RECOMMENDED XPS OIL IS NOT AVAILABLE
Use a 75W140 gear oil that meets the API GL-5 specification

NOTICE

The gearbox of this snowmobile has been developed and validated using the XPS synchronesh transmission synthetic oil. BRP strongly recommends the use of its synchronesh transmission synthetic oil at all times. Damages caused by oil which is not suitable for the gearbox will not be covered by the BRP limited warranty.

Gearbox Oil Level

With the vehicle on a level surface, check the oil level by removing the check plug on the left side of gearbox.

Oil level must reach the threaded hole's lower edge.

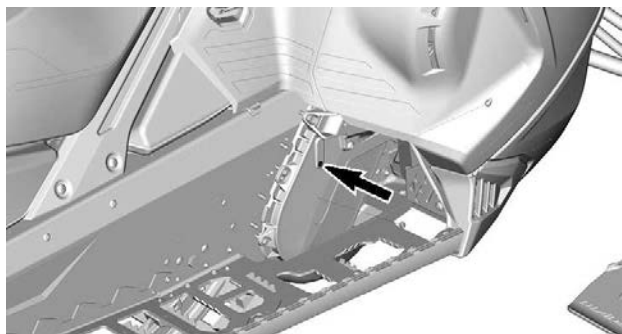

CHECK PLUG.

To add oil, proceed as follows:

1. Remove the filler plug.

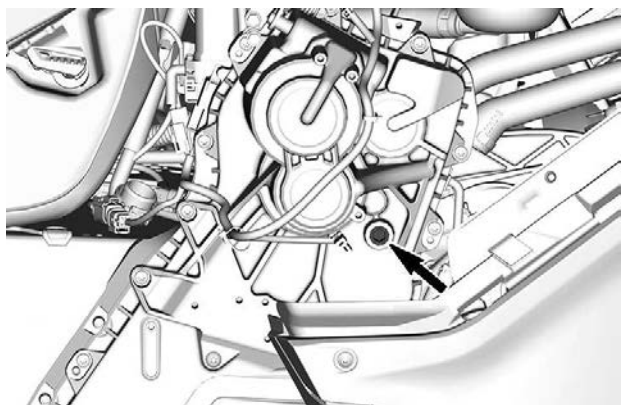

FILLER PLUG

2. Pour recommended oil in gearbox by the filler hole until oil comes out by the check plug hole.
3. Reinstall check and filler plug and tighten to specifications.

TIGHTENING TORQUE	
Check plug	6 ± 1 Nm (53 ± 9 lbf-in)
Filler plug	8 ± 1 Nm (71 ± 9 lbf-in)

Replacing the Gearbox Oil

Gearbox Oil Draining

1. Place the vehicle on a level surface.
2. Place a drain pan under gearbox drain plug area.
3. Remove filler cap.
4. Remove the drain plug located at the bottom of gearbox.

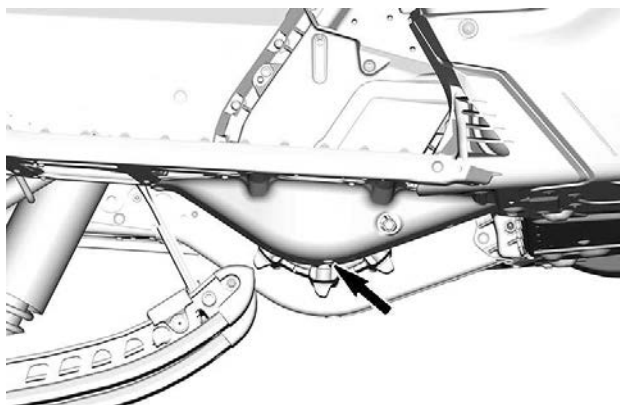

5. Wait a while to allow all oil to drain out of gearbox.
6. Install drain plug and tighten to specification.

Tightening Torque	
Gearbox drain plug	6 ± 1 Nm (53 ± 9 lbf-in)

Gearbox Oil Filling

NOTE:

Vehicle must be on a level surface.

1. Remove the filler plug.
2. Remove oil level check plug.

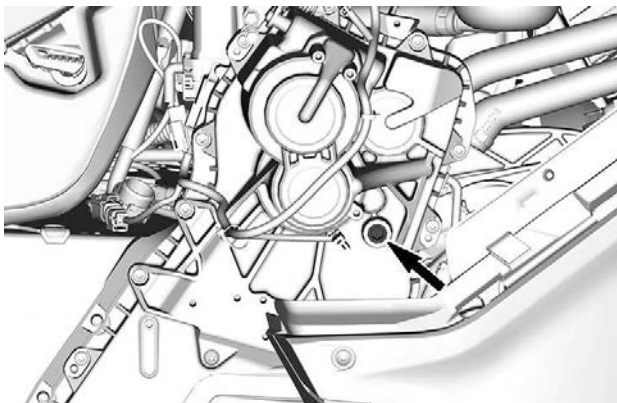

FILLER PLUG

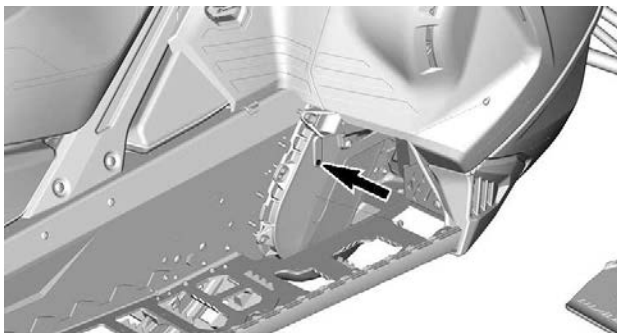

CHECK PLUG

3. Pour recommended oil into gearbox through the filler hole.

NOTE:

Oil level is correct when it just begins to come out of the check plug orifice.

4. Reinstall check plug and tighten to specification.

tightening torque	
Oil level check plug	6 ± 1 Nm (53 ± 9 lbf-in)

Drive Chain

Access to Chaincase

Open RH side panel, refer to *Equipment*.

Drive Chain Adjustment

Using the Torx end of the driven pulley expander, GENTLY turn tensioner clockwise to eliminate the play.

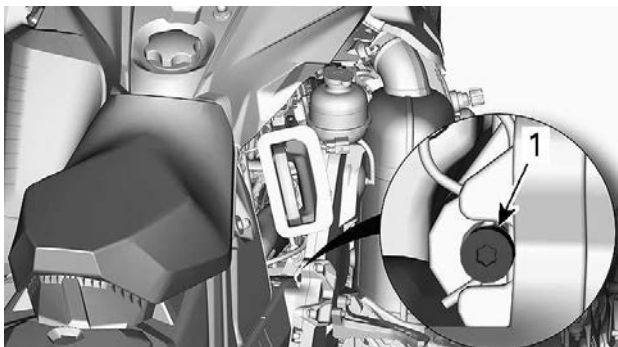

TYPICAL

Do not force the tensioner in.

NOTE:

Do not remove the hair cotter pin.

NOTICE

Overtightening the drive chain could result in severe damage to the chaincase components.

Drive Belt

Drive Belt Inspection

Remove the drive belt guard. Refer to the procedure in *Equipment*.

Inspect belt for cracks, fraying or abnormal wear (uneven wear, wear on one side, missing cogs, cracked fabric). If abnormal wear is noted, probable cause could be pulley misalignment, excessive RPM with frozen track, fast starts without warm-up period, burred or rusty sheave, oil on belt or distorted spare belt. Contact an authorized BRP snowmobile dealer.

Replacing the Drive Belt

Removing the Drive Belt

1. Remove the tether cord cap from engine cut-off switch.
2. Remove the LH side panel.
3. Remove the drive belt guard. Refer to *Removing the Drive Belt Guard*.
4. Insert the driven pulley expander provided, in the threaded hole on the adjuster hub as shown.

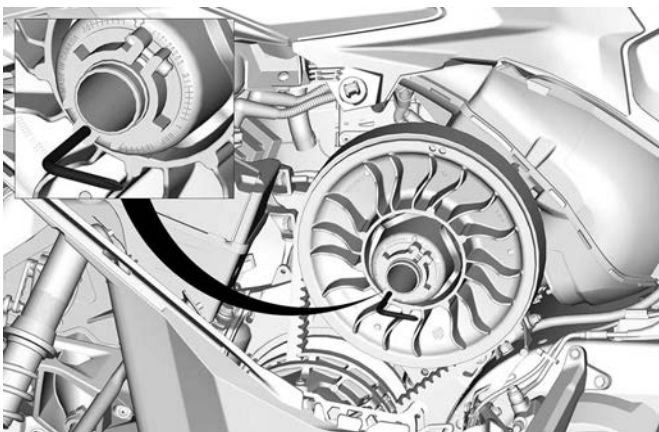

TYPICAL - PULLEY EXPANDER INSTALLED ON ADJUSTER HUB

5. Open the driven pulley by screwing the tool in.
6. Remove the drive belt by slipping it over the edge of the driven pulley, then over the drive pulley.

Installing the Drive Belt

The driven pulley must be expanded. Refer to *Removing the Drive Belt*.

1. Slip the belt over the drive pulley, then over the driven pulley.

NOTICE

Do not force or use tools to pry the belt into place, as this could cut or break the cords in the belt.

NOTE:

The maximum drive belt life span is obtained when belt is installed with arrows in the direction of rotation.

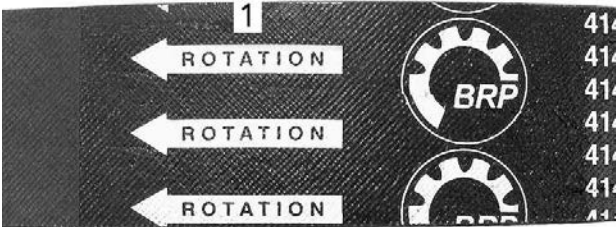

1. To be pointed in the direction of rotation
2. Unscrew and remove the driven pulley expander from the pulley.
3. Rotate the driven pulley several times to properly set the belt between the sheaves.
4. If a new belt was installed, an adjustment will be required for the proper belt height. Refer to *Adjusting the Drive Belt Height*.
5. Install belt guard.
6. Close side panel.

Adjusting the Drive Belt Height

Remove the tether cord cap from engine cut-off switch.

Remove the LH side panel.

Remove the drive belt guard.

1. Loosen the clamping bolt.

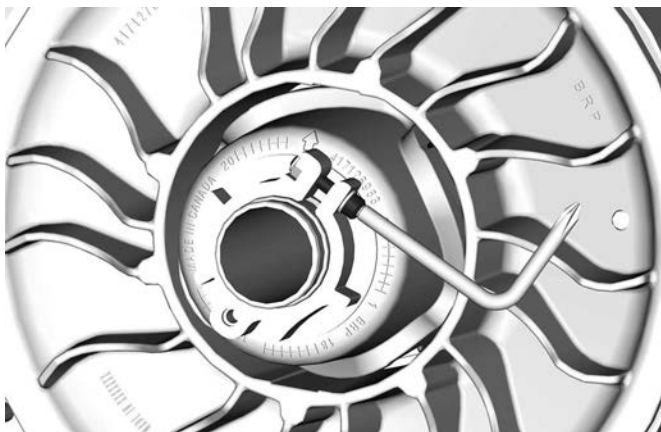

2. Using the suspension adjustment tool provided, turn the ring 1/4 turn at a time then rotate the driven pulley to properly set the drive belt between the pulley sheaves.

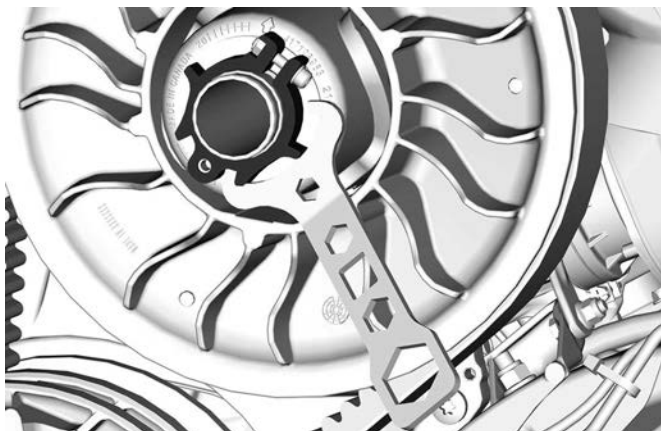

NOTE:

The adjustment ring has left hand treads.

Repeat step 4 until the lowest portion of the cogs on the external surface of drive belt is even with the driven pulley edge.

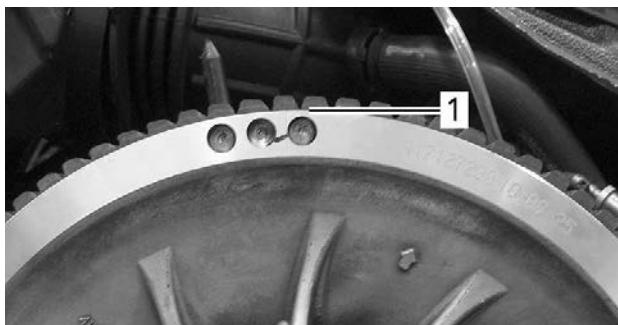
**TYPICAL - PRELIMINARY SETTING**

1. Lowest portion of cogs even with external surface of drive belt

NOTE:

Turning the ring counterclockwise lowers the drive belt in the pulley. Turning the ring clockwise raises the drive belt in the pulley.

3. Firmly tighten the clamping bolt. If possible, tighten to specified torque using a torque wrench.

TIGHTENING TORQUE	
Clamping bolt	5.5 ± 0.5 Nm (49 ± 4 lbf-in)

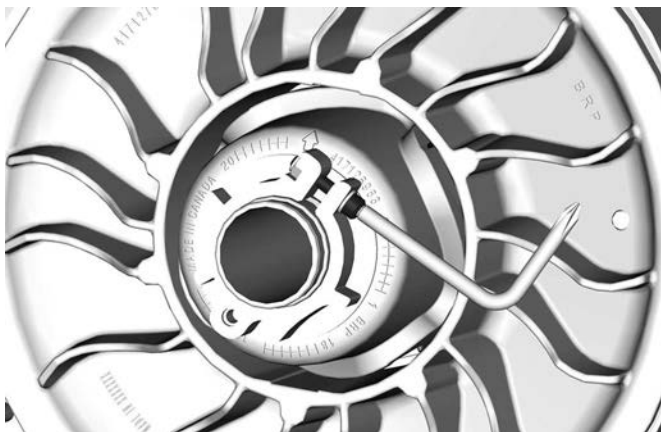

4. Install belt guard, refer to *Installing the Drive Belt Guard*.
5. Install LH side panel.
6. Start engine and check if vehicle creeps.
7. If vehicle does not creep, adjustment is complete.
8. If vehicle creeps, check the drive belt deflection.

Reverse Activation (if equipped)

Reverse may not activate or may be harder to activate if the belt is positioned too high in the driven pulley. If reverse activation does not work properly, ensure the drive belt is properly adjusted.

Adjust the drive belt lower in the driven pulley if needed.

Track

Track Condition

⚠ WARNING

Remove tether cord cap from engine cut-off switch before performing any maintenance or adjustment, unless otherwise specified. Vehicle must be parked in a safe place, away from the trail.

Remove tether cord cap from engine cut-off switch.

Lift the rear of the snowmobile and support it with a wide-base snowmobile mechanical stand with a rear deflector panel. With the engine off, rotate the track by hand, and inspect condition. If worn or cut, or if track fibers are exposed, or if missing or defective inserts or guides are noted; contact an authorized BRP snowmobile dealer.

Snowmobiles Equipped with Traction Enhancing Products

If your snowmobile is equipped with a BRP approved studded track, **PROCEED WITH A VISUAL INSPECTION OF YOUR TRACK BEFORE EACH USE.**

Look for any defects, such as:

- Perforations in the track
- Tears in the track (particularly around traction holes on studded tracks)
- Lugs that are broken or torn off, exposing portions of rods
- Delamination of the rubber
- Broken rods
- Broken studs (studded tracks)
- Bent studs (studded tracks)
- Missing studs
- Studs that are torn off the track
- Missing track guide(s)
- Also, ensure that studs nut are tighten to the recommended torque.

On approved studded tracks, replace broken or damaged studs immediately. If your track shows signs of deterioration, it must be replaced immediately. When in doubt, ask your dealer.

WARNING

Riding with a damaged track or studs could lead to a loss of control.

For complete information on traction enhancing products, refer to *TRACTION ENHANCING PRODUCTS* in *SAFETY INFORMATION* at the beginning of this Operator's Guide.

Track Tension and Alignment

NOTE:

Track tension and alignment are interrelated. Do not adjust one without the other.

⚠ WARNING

To prevent serious injury to individuals near the snowmobile:

- NEVER stand behind or near a moving track.
- Always use a wide-base snowmobile stand with a rear deflector panel if it is necessary to rotate track.
- When the track is raised off the ground, only run it at the lowest possible speed.

Centrifugal force could cause debris, damaged or loose studs, pieces of torn track, or an entire severed track to be violently thrown backwards out of the tunnel with tremendous force, possibly resulting in the loss of a leg or other serious injury.

Verifying the Track Tension

NOTE:

Ride the snowmobile in snow about 15 to 20 minutes prior to adjusting track tension.

1. Remove tether cord cap from engine cut-off switch.
2. Lift rear of vehicle and support it off the ground.

⚠ CAUTION

Use proper lifting techniques, notably using your legs force. Do not attempt to lift the rear of vehicle if it is above your limits.

3. Allow rear suspension to fully extend.
4. Prepare the tensiometer.

Service tool	
Tensiometer (P/N 414348200)	

1. Set the bottom O-ring as per the *Track Deflection* from the applicable vehicle in the *Technical Specifications* table.



1. Bottom O-ring

2. Place the upper O-ring to 0 kgf (0 lbf).



1. Upper O-ring

5. Position the tensiometer on track, halfway between front and rear idler wheels.
6. Push the tensiometer downwards until bottom O-ring (deflection set earlier) be aligned with the bottom of slider shoe.

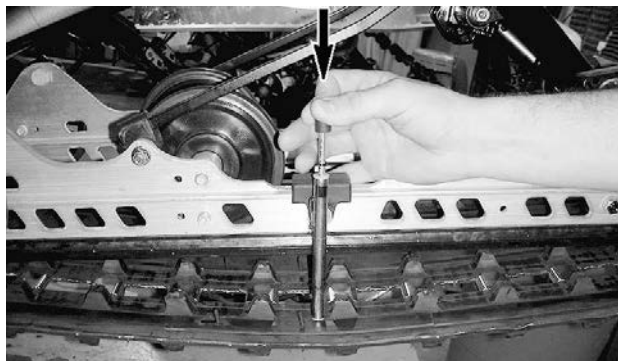

TYPICAL

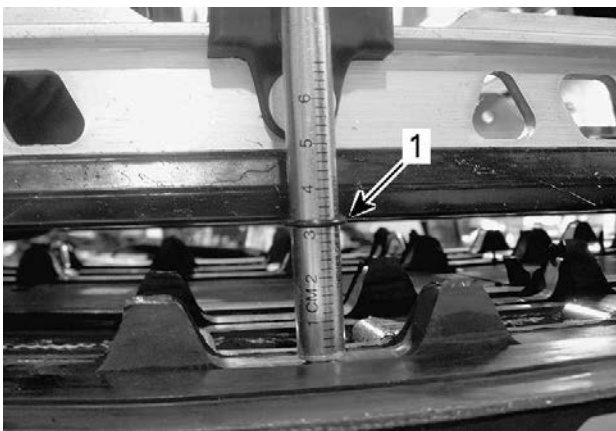

TYPICAL

1. Deflection O-ring aligned with slider shoe

7. Read load recorded by the upper O-ring on the tensiometer.



TYPICAL - LOAD READING

1. Upper O-ring

8. Load reading must be as per the track deflection in the *Technical Specifications*.
9. If load reading is not in accordance with the specification, adjust track tension. Refer to *Track Tension Adjustment*.

Adjusting the Track Tension - EasyRide-A Suspension

1. Remove the tether cord cap from engine cut-off switch.
2. Lift rear of vehicle and support it off the ground.

⚠ CAUTION

Use proper lifting techniques, notably using your legs force. Do not attempt to lift the rear of vehicle if it is above your limits.

3. Allow rear suspension to fully extend.
4. Remove rear wheel caps.

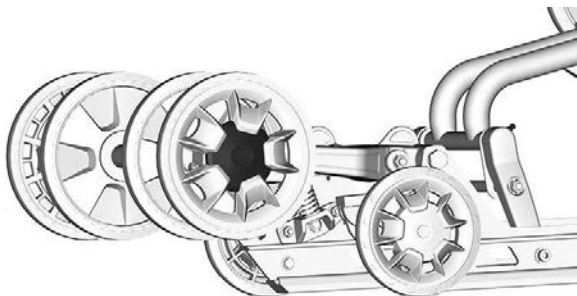

5. Loosen the rear idler wheels retaining screws.

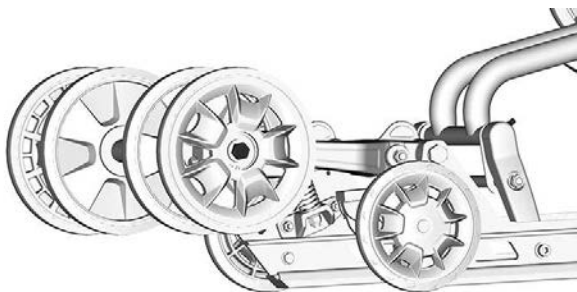

6. Tighten or loosen both adjustment screws to increase or decrease track tension.

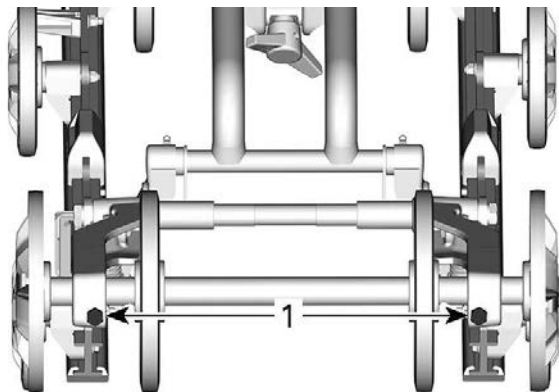

1. Adjustment screws

NOTE:

It may be necessary to rotate the driven pulley to access the adjustment screw.

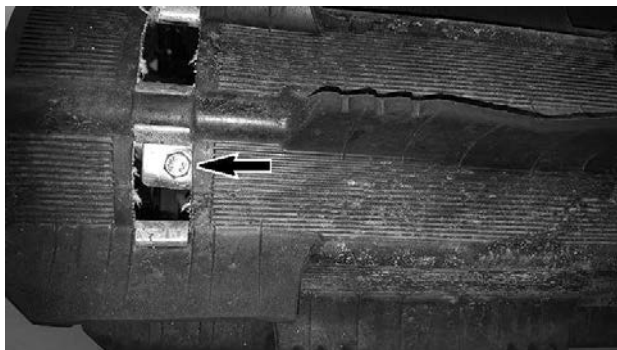

7. If correct tension is unattainable, contact an authorized BRP snowmobile dealer.
8. Retighten idler wheels retaining screws to specification.

TIGHTENING TORQUE	
Idler wheel screw	48 ± 6 Nm (35 ± 4 lbf-ft)

9. Check track alignment as described below.

Aligning the Track

WARNING

Before checking track alignment, ensure that the track is free of all particles which could be thrown out while track is rotating. Keep hands, tools, feet and clothing clear of track. Always lift the snowmobile on a wide-base stand with a rear deflector panel. Ensure no one is standing in close proximity to the snowmobile, especially at the rear of the track. Never rotate track at high speed.

Centrifugal force could cause debris, damaged or loose studs, pieces of torn track, or an entire severed track to be violently thrown backwards out of the tunnel with tremendous force.

1. Lift rear of vehicle and support it off the ground.

CAUTION

Use proper lifting techniques, notably by using the force of your legs. Do not attempt to lift the rear of vehicle if it is above your limits.

2. Start engine and accelerate slightly so that track slowly turns. This must be done in a short period of time (15 to 20 seconds).
3. Check that the track is well centered; equal distance on both sides between edges of track guides and slider shoes.

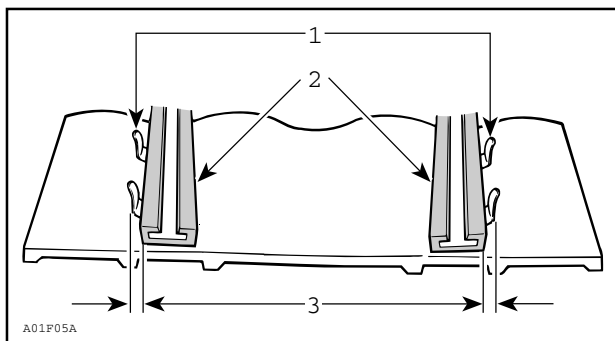

1. Guides
2. Slider shoes
3. Equal distance

4. To correct track alignment:

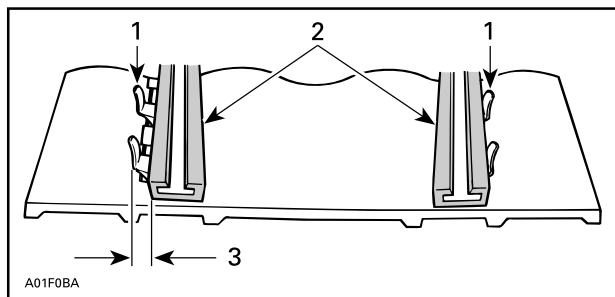

1. Guides
2. Slider shoes
3. Tighten on this side

1. Stop engine.
2. Remove tether cord cap from engine cut-off switch.

⚠ WARNING

Remove tether cord cap from engine cut-off switch before performing any maintenance or adjustment, unless otherwise specified. Vehicle must be parked in a safe place, away from the trail.

3. Loosen the rear axle nut.
4. Tighten adjustment screw on side where the slider shoe is the farthest from the track insert guides.
5. Tighten the rear axle nut.

⚠ WARNING

Properly tighten wheel retaining bolt, otherwise wheel may come off and cause track to "lock".

6. Restart engine and rotate track slowly to recheck alignment.
7. Tighten the rear axle nut to specified torque.

Tightening Torque	
Rear axle screw	48 ± 6 Nm (35 ± 4 lbf-ft)

8. Reposition snowmobile on the ground.

Suspension

Rear Suspension Condition

Visually inspect all suspension components including slider shoes, springs, wheels, etc.

NOTE:

During normal driving, snow will act as a lubricant and coolant for the slider shoes. Extensive riding on ice or sanded snow, will create excessive heat build-up and cause premature slider shoe wear.

Suspension Stopper Strap Condition

Inspect stopper straps for wear and cracks, bolt and nut for tightness. If loose inspect holes for deformation. Replace as required. Tighten nut to specification.

Tightening Torque	
-------------------	--

Stopper strap nut	11 ± 1 Nm (97 ± 9 lbf-in)
-------------------	---------------------------

Suspension Lubrication – EasyRide

Lubricate the following suspension pivots at grease fittings. Refer to *Maintenance Schedule* for maintenance frequency.

Suspension Grease

XPS Synthetic suspension grease

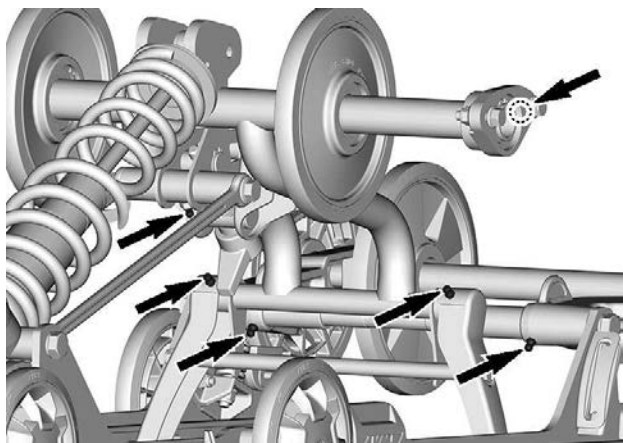
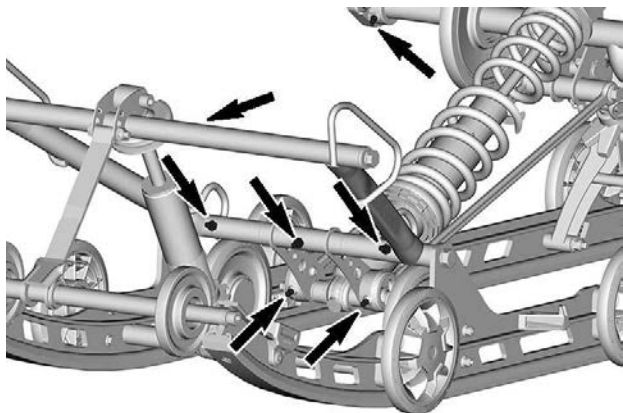

Steering and Front Suspension Condition

Visually inspect steering and front suspension for tightness of components (steering arms, control arms and links, tie rods, ball joints, ski bolts, ski legs, etc.). If necessary, contact an authorized BRP snowmobile dealer.

Skis

Wear and Condition of Skis and Runners

Check the condition of the skis and ski runner carbides. If worn, contact an authorized BRP snowmobile dealer.

⚠ WARNING

Excessively worn skis and/or ski runners will adversely affect snowmobile control.

Fuses

Access to Fuse Block

Open RH side panel, refer to *Body and Seat*.

Fuses Location

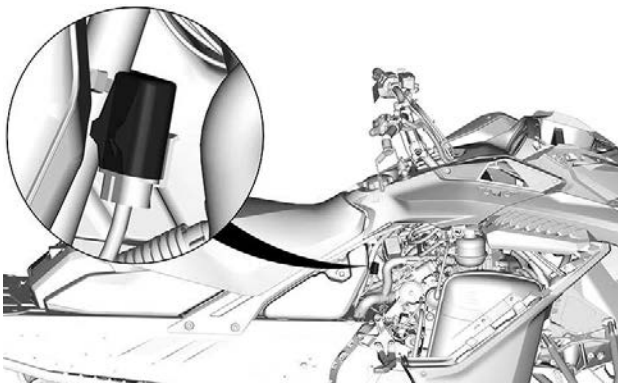

TYPICAL - FA

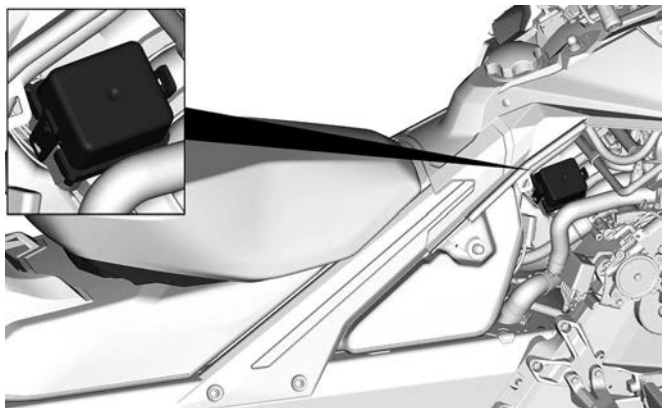

TYPICAL – FUSE BOX 1 (FB1)

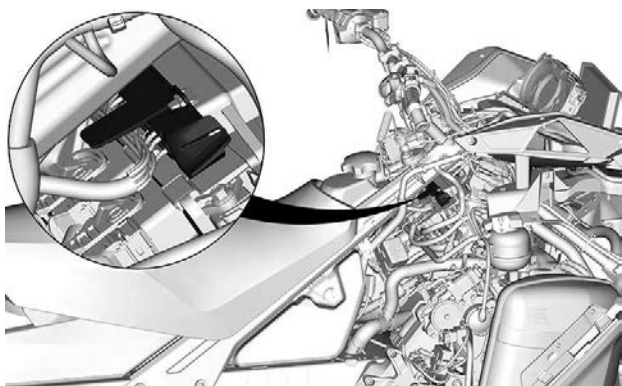

TYPICAL – RELAY BLOCK - IF EQUIPPED

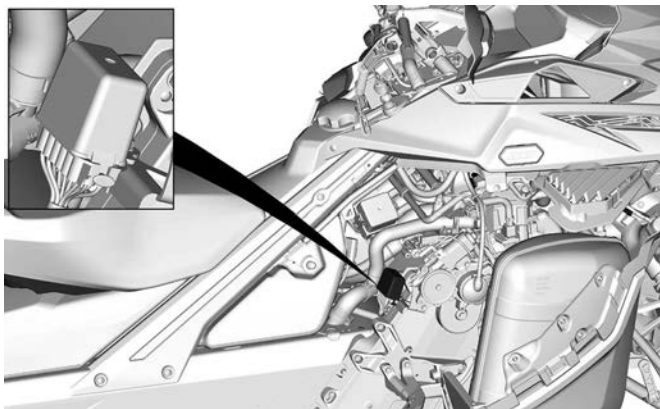

TYPICAL – FUSE BOX 2 (FB2) - IF EQUIPPED

Refer to *Technical Specification* for relay and fuse identification.

Fuse Inspection

Check fuse condition and replace it if necessary.

To remove fuse from holder, pull fuse out. Check if filament is melted.

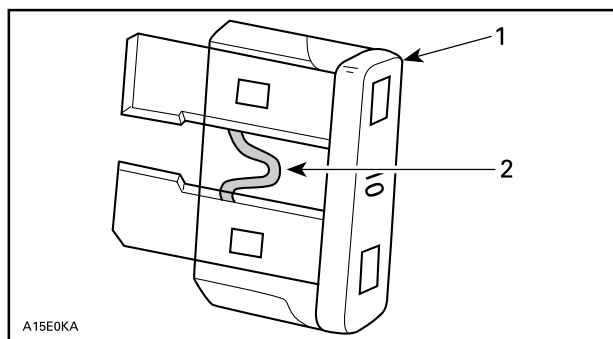

1. Fuse
2. Check if melted

⚠ WARNING

Do not use a higher rated fuse.

⚠ WARNING

If fuse has burnt out, source of malfunction should be determined and corrected before restarting. See an authorized BRP snowmobile dealer for servicing.

Headlights

Headlights Bulb Replacement

1. Remove the windshield. Refer to *Removing the Windshield* in *Body and Seat* subsection.
2. Open the storage compartment.

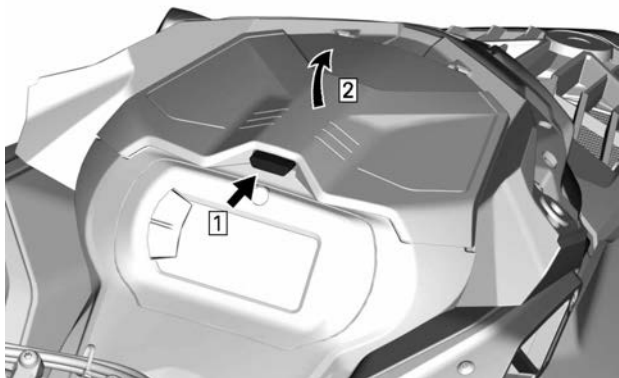

TYPICAL

3. Remove the gauge support retaining screws.



4. Lift the front of the gauge support, then slide it forward to remove it.

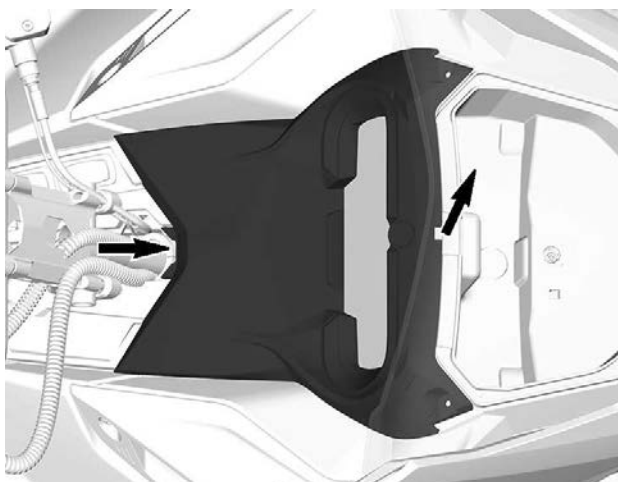

5. Set gauge support aside.
6. Remove the storage compartment.

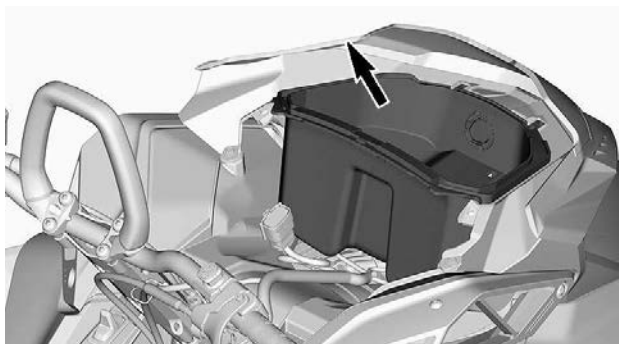

7. Disconnect 12V power outlet connectors to remove (if equipped).
8. Disconnect bulb connector.

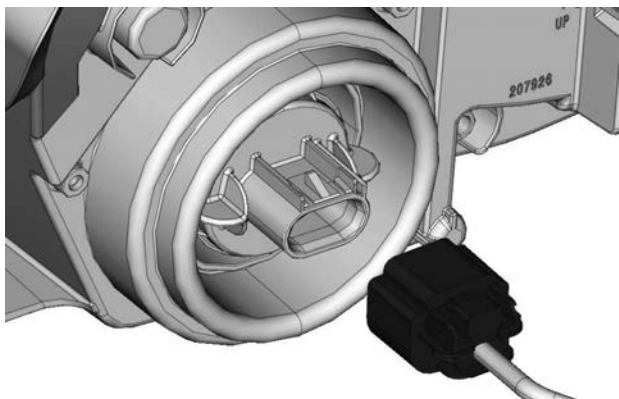

9. Unlock bulb by turning it counterclockwise.
10. Pull bulb out.

NOTE:
Ensure bulb seal stays in place.

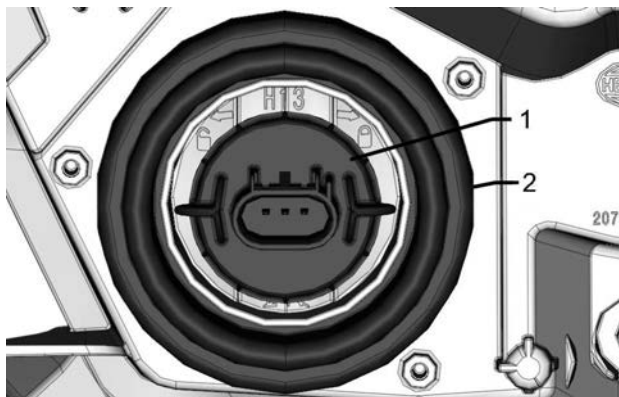

1. Bulb
2. Bulb seal

Install a new bulb using the reverse of the removal procedure.

NOTICE

Never touch glass portion of an halogen bulb with bare fingers, it shortens its operating life. If glass is touched, clean it with isopropyl alcohol which will not leave a film on the bulb.

Check headlights operation.

Headlights Beam Aiming

Open the storage compartment.

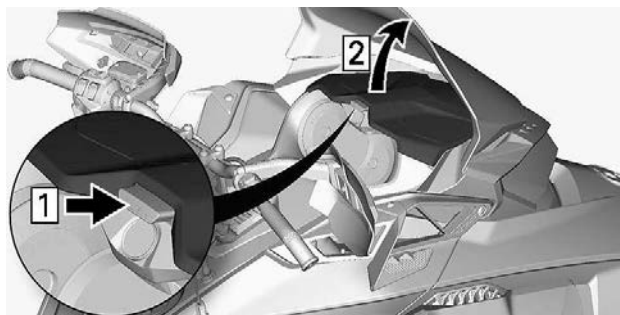
**TYPICAL**

Turn the adjustment screw to reach desired beam height.

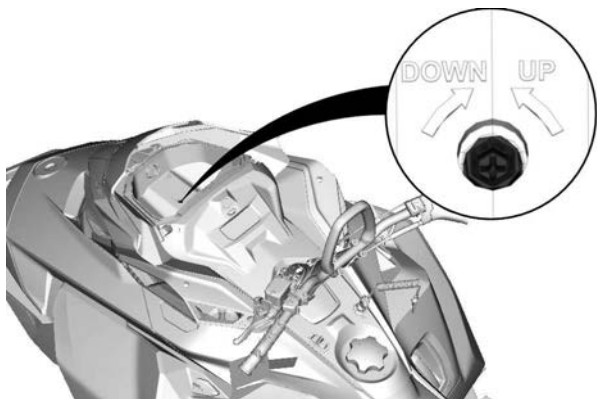
**Battery**

400 mm (16 in.) Tunnel Width

Removing the Battery

1. Remove the seat.
2. Remove the battery cover.

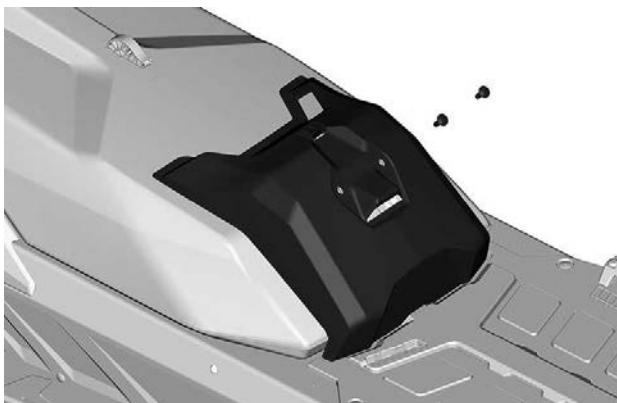

TYPICAL

3. Disconnect the negative terminal first, then the positive terminal.

NOTICE

Battery BLACK (-) cable must always be disconnected first and connected last.

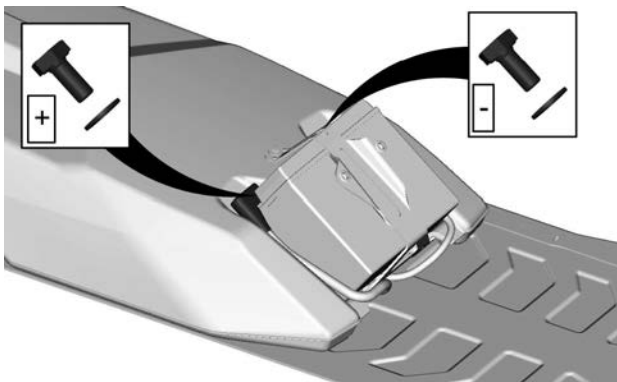

4. Remove the battery hold down bracket.

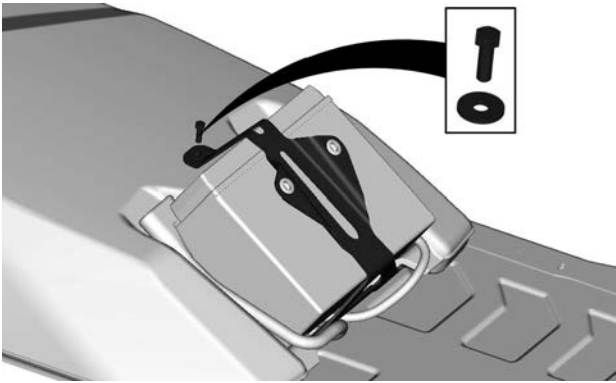

5. Remove the battery.

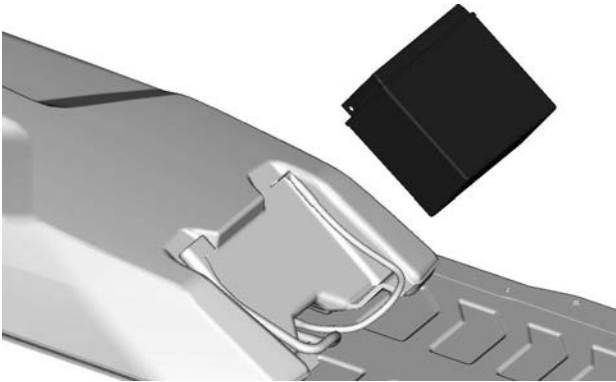

Installing the Battery

NOTICE

Battery BLACK (-) cable must always be disconnected first and connected last.

The installation is the reverse of the removal procedure. However, pay attention to the following details.

TIGHTENING TORQUE	
Battery terminals (positive and negative)	10 ± 2 Nm (89 ± 18 lbf-in)
Battery hold down bracket	5 ± 0.5 Nm (44 ± 4 lbf-in)
Battery cover retaining screws	1.5 ± 0.5 Nm (13 ± 4 lbf-in)

500 and 600 mm (20 and 24 in.) Tunnel Width**Removing the Battery**

1. Remove the passenger seat and backrest, if equipped.
2. Open the cargo box, remove the battery cover and all mounting screws.

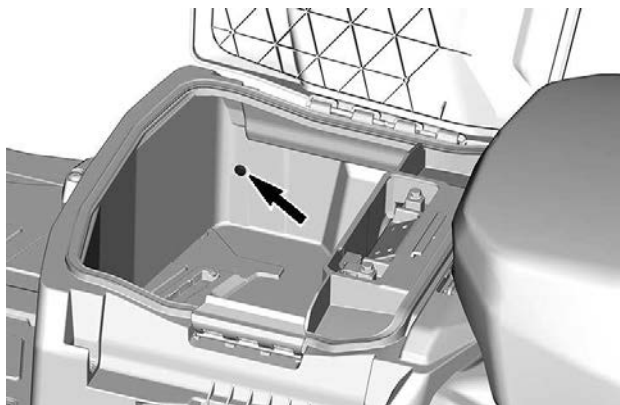

LH SIDE SCREW SHOWN

3. Remove the cargo box.



4. Disconnect the negative terminal first, then the positive terminal.

NOTICE

Battery BLACK (-) cable must always be disconnected first and connected last.

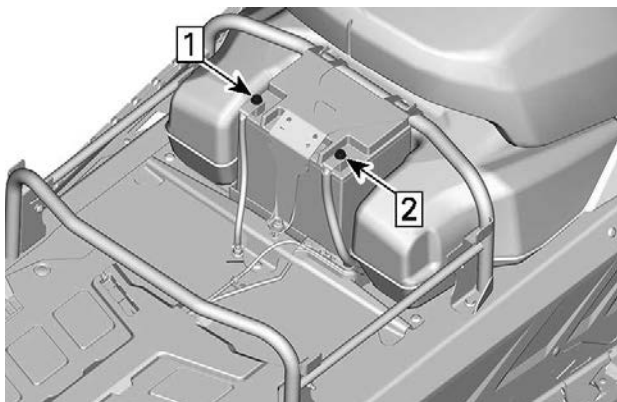

1. *Disconnect negative*
2. *Disconnect positive*

5. Remove the battery hold down bracket.

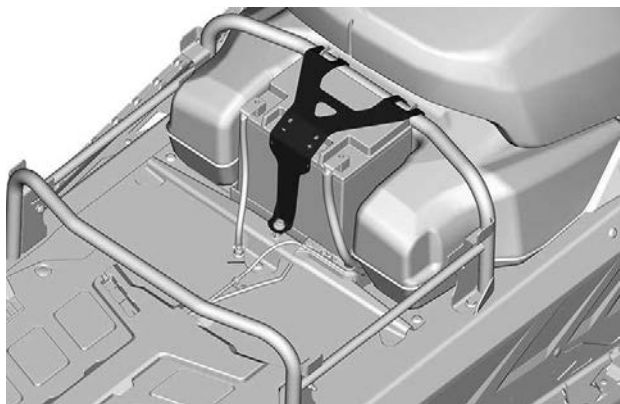

6. Remove the battery.

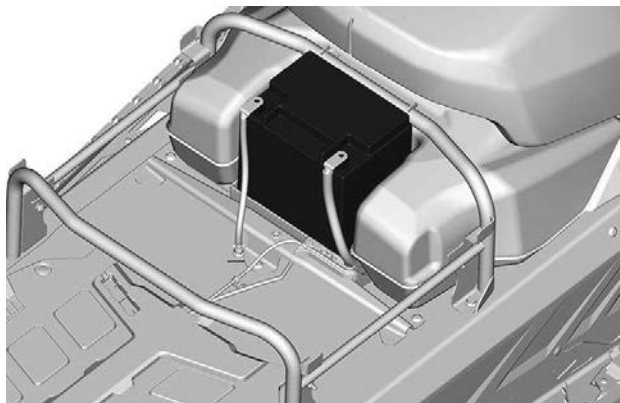

Installing the Battery

The installation is the reverse of the removal procedure. However, pay attention to the following details.

TIGHTENING TORQUE	
Battery terminals (positive and negative)	10 ± 2 Nm (89 ± 18 lbf-in)
Battery hold down bracket	5 ± 0.5 Nm (44 ± 4 lbf-in)
Battery cover retaining screws	5 ± 0.5 Nm (44 ± 4 lbf-in)

VEHICLE CARE

Post-Operation Care

Remove snow and ice from rear suspension, track, front suspension, steering mechanism and skis.

 **WARNING**

Make sure D.E.S.S. key is removed from D.E.S.S. post before standing in front the vehicle, getting close to the track or rear suspension components.

Always cover your snowmobile when leaving it outside overnight or during extended periods of inactivity. This will protect it from frost and snow as well as help retain its appearance.

Vehicle Cleaning and Protection

Wash snowmobile using water mixed with a mild detergent.

Use only microfiber cloths or an equivalent.

NOTICE

Never use a high pressure washer to clean the vehicle. Use low pressure only, like a garden hose.

Non Compatible Cleaning Products

Material Type	Non-Compatible Cleaning Products
All plastics, vinyls, painted steel and aluminium	BRAKE AND PARTS CLEANER OR ANY PETROLEUM BASE CLEANING PRODUCTS

Compatible Cleaning Products

Material Type	Cleaning Product
All plastics, vinyls, painted steel and aluminium.	Automotive type soap with water XPS Spray Cleaner and Polish XPS All Purpose Cleaner

For more information and products, Visit the XPS Products website at www.xpslubricants.com

STORAGE

During summer, or when a snowmobile is not in use for more than three months, proper storage is necessary.

Storage
Clean the vehicle
Add fuel stabilizer to fuel following the product manufacturer recommendations. Run the engine after adding the product to the fuel
Lubricate engine
Lubricate brake lever pivot
Lubricate rear suspension
Charge battery monthly to keep it fully charged during storage
Block muffler outlet with rags
Lift rear of vehicle until track is clear of the ground. Do not release track tension

CAUTION

Use appropriate lifting device or have assistance to share lifting stress. If a lifting device is not used, use proper lifting techniques, notably using your legs force. Do not attempt to lift the rear of vehicle if it is above your limits.

NOTICE

The snowmobile has to be stored in a cool and dry place and covered with an opaque but ventilated tarpaulin. This will prevent sun rays and grime from affecting plastic components and vehicle finish.

NOTICE

Fuel stabilizer should be added prior to engine lubrication to ensure carburetor protection against varnish deposits.

PRESEASON PREPARATION

Proper vehicle preparation is necessary when a vehicle has not been used for more than three months.

Using the *maintenance schedule*, perform the items titled *EVERY YEAR AT PRESEASON*.

Visit your authorized BRP snowmobile dealer for more information.

MAINTENANCE RECORDS

Send photocopy of maintenance record to BRP if needed.

Pre-delivery	
Serial number: _____	Signature/Print:
Mileage / km: _____	
Hours: _____	
Date: _____	
Dealer no: _____	
Notes: _____	

Refer to vehicle Pre-Delivery Bulletin for detailed installation procedures	

First inspection

Mileage / km: _____ Hours: _____ Date: _____ Dealer no: _____ Notes: _____ _____ _____	Signature/Print:
----------------------------------------------------------------------------------------------------------	------------------

For maintenance schedule refer to Maintenance Information section of this operator's guide

Service

Mileage / km: _____ Hours: _____ Date: _____ Dealer no: _____ Notes: _____ _____ _____	Signature/Print:
----------------------------------------------------------------------------------------------------------	------------------

For maintenance schedule refer to Maintenance Information section of this operator's guide

Service	
Mileage / km:	Signature/Print:
Hours:	
Date:	
Dealer no:	
Notes:	
For maintenance schedule refer to Maintenance Information section of this operator's guide	

Service	
Mileage / km:	Signature/Print:
Hours:	
Date:	
Dealer no:	
Notes:	
For maintenance schedule refer to Maintenance Information section of this operator's guide	

Service	
Mileage / km: _____ Hours: _____ Date: _____ Dealer no: _____ Notes: _____ _____ _____	Signature/Print:
For maintenance schedule refer to Maintenance Information section of this operator's guide	

Service	
Mileage / km: _____ Hours: _____ Date: _____ Dealer no: _____ Notes: _____ _____ _____	Signature/Print:
For maintenance schedule refer to Maintenance Information section of this operator's guide	

Service	
Mileage / km: _____	Signature/Print:
Hours: _____	
Date: _____	
Dealer no: _____	
Notes: _____	

For maintenance schedule refer to Maintenance Information section of this operator's guide	

Service	
Mileage / km: _____	Signature/Print:
Hours: _____	
Date: _____	
Dealer no: _____	
Notes: _____	

For maintenance schedule refer to Maintenance Information section of this operator's guide	

Service	
Mileage / km: _____ Hours: _____ Date: _____ Dealer no: _____ Notes: _____ _____ _____	Signature/Print:
For maintenance schedule refer to Maintenance Information section of this operator's guide	

Service	
Mileage / km: _____ Hours: _____ Date: _____ Dealer no: _____ Notes: _____ _____ _____	Signature/Print:
For maintenance schedule refer to Maintenance Information section of this operator's guide	

Service	
Mileage / km: _____	Signature/Print:
Hours: _____	
Date: _____	
Dealer no: _____	
Notes: _____	

For maintenance schedule refer to Maintenance Information section of this operator's guide	

Service	
Mileage / km: _____	Signature/Print:
Hours: _____	
Date: _____	
Dealer no: _____	
Notes: _____	

For maintenance schedule refer to Maintenance Information section of this operator's guide	

Service	
Mileage / km: _____ Hours: _____ Date: _____ Dealer no: _____ Notes: _____ _____ _____	Signature/Print:
For maintenance schedule refer to Maintenance Information section of this operator's guide	

Service	
Mileage / km: _____ Hours: _____ Date: _____ Dealer no: _____ Notes: _____ _____ _____	Signature/Print:
For maintenance schedule refer to Maintenance Information section of this operator's guide	

This page is intentionally blank

TECHNICAL INFORMATION

VEHICLE IDENTIFICATION

Vehicle Description Decal

Vehicle description decal is located on right hand side of tunnel.

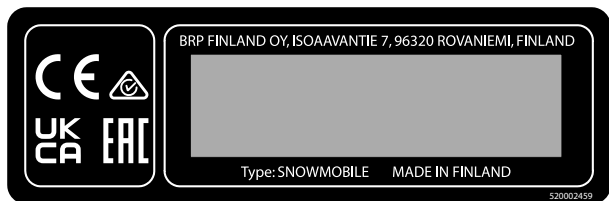
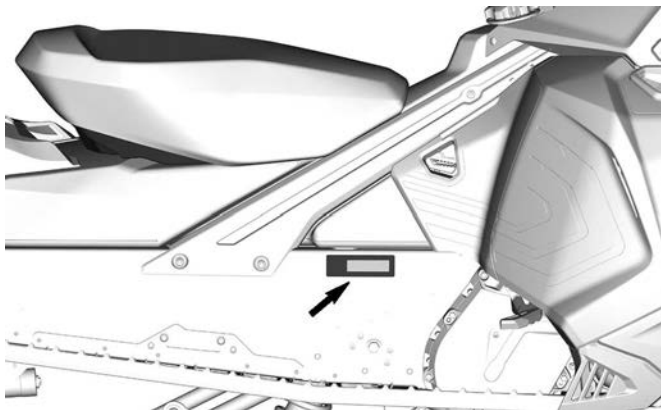

FOR EUROPEAN MARKET

Identification Numbers

The main components of your snowmobile (engine and frame) are identified by different identification numbers. It may sometimes become necessary to locate these numbers for warranty purposes or to trace your snowmobile in the event of loss. These numbers are required by the authorized BRP snowmobile dealer to complete warranty claims properly. We strongly recommend that you take note of all the identification numbers on your snowmobile and supply them to your insurance company.

Vehicle Identification Number (VIN)

VIN is scribed on vehicle description decal. See above. It is also engraved on tunnel near vehicle description decal.

Model number and model year are part of the information found in the VIN. See illustration.

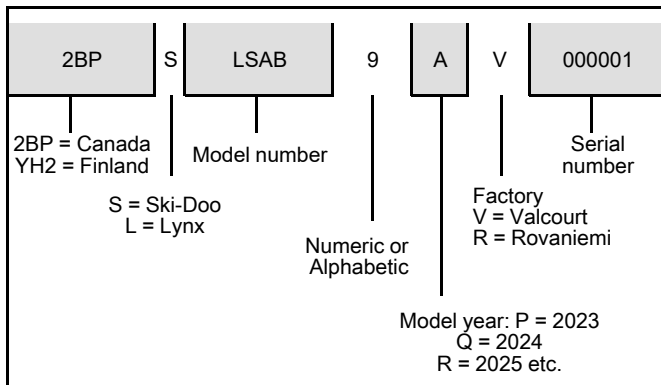
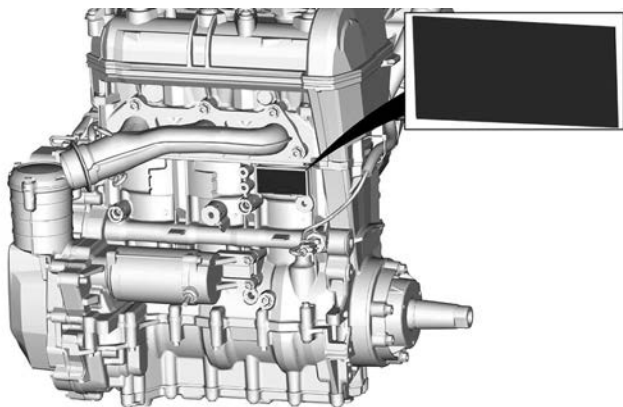
**Engine Identification Number Location**

COMPLIANCE LABELS

Regulation (EU) 2016/1628 applicable for Non-Road Mobile Machineries

Vehicles who comply to Regulation (EU) 2016/1628 (NRMM) are identified on the engine valve cover.

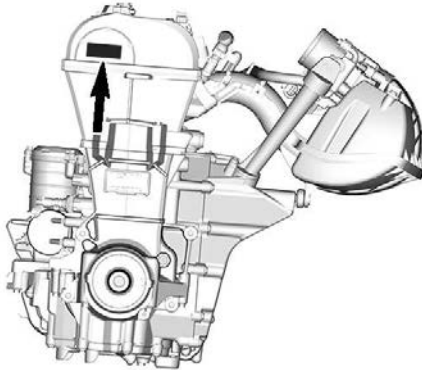

TYPICAL

10997 	Rotax	NRSC H CO2 g/kWh: xxxx
		# XXXXXXXXX
	Prod. date:	XX-XXXX
	Family type:	XXXXXX
	eXX	SMB/P V-XXXX

NRMM IDENTIFICATION ON ENGINE

COMPLIANCE LABELS

Depending on your particular vehicle configuration, an additional NRMM identification decal may be installed on the tunnel, near the gearbox.

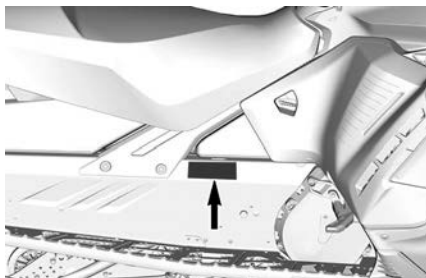

TYPICAL - ON RH SIDE OF TUNNEL



NRMM IDENTIFICATION ON VEHICLE

NOISE EMISSION AND VIBRATION VALUES

MODEL		600 ACE	900 ACE
NOISE EMISSION AND VIBRATION VALUES ¹			
Noise	Sound power level (L _{WA})	90,4 dB @ 3625 RPM (Uncertainty (K _{wa}) 3 dB)	91,2 dB @ 3625 RPM (Uncertainty (K _{wa}) 3 dB)
Vibration	Hand-arm system	<2.5 m/s ² @ 3625 RPM	3.15 m/s ² @ 3625 RPM
	Whole body at seat	<0.5 m/s ² @ 3625 RPM	<0.5m/s ² @ 3625 RPM
1: Noise emission and Vibration values are measured in accordance with Annexes A and B of ISMA 1 regulation on a snow covered or grass surface in neutral or without belt.			

MODEL		900 ACE Turbo (130 hp) and Turbo R (180 hp)
NOISE EMISSION AND VIBRATION VALUES ¹		
Noise	Sound power level (L _{WA})	99 dB @ 3625 RPM (Uncertainty (K _{wa}) 3 dB)
	Sound pressure (L _{pA})	92 dB @ 3625 RPM (Uncertainty (K _{pa}) 3 dB)
Vibration	Hand-arm system	<2.5 m/s ² @ 3625 RPM
	Whole body at seat	<0.5m/s ² @ 3625 RPM
1: Noise emission and Vibration values are measured in accordance with Annexes A and B of ISMA 1 regulation on a snow covered or grass surface in neutral or without belt.		

UK DECLARATION OF CONFORMITY



ADVENTURE BY DESIGN

BRP Finland Oy
PL 8040 (Rovaniemi 7)
FI-96101 Rovaniemi, Finland
T 358 40 800 7700
F 358 16 318 114
www.brp.com

UK Declaration of Conformity

Authorized Representative: BRP Recreational Products UK Ltd., Castle Chambers, 43 Castle Street, Liverpool, L2 9SH

This declaration of conformity is issued under the sole responsibility of the manufacturer.

The undersigned, representing the manufacturer, hereby declares that model year **2024**

Snowmobile marked with the ^{UK} mark and a 17-character vehicle identification number (VIN) structured as **YH2LxxxxRRxxxxxx** under commercial name **Lynx** comply with all the relevant provisions of the following UK Statutory instrument and Regulations:

The Supply of Machinery (Safety) Regulations 2008, UK Statutory Instrument 2008/1597 as amended up to and including SI 2020/1112	ISO 12100:2010
Non-Road Mobile Machinery (Type-Approval and Emission of Gaseous and Particulate Pollutants) Regulation 2018, UK SI 2018/764 as amended up to and including SI 2020/1393	Category SMB, Stage V emissions limits
Electromagnetic Compatibility Regulations 2016, UK SI 2016/1091 as amended up to and including SI 2020/1112	CISPR 12:2007/A1:2009 & IEC 61000-6-1:2005 or UN R10.04 or later version
Batteries and Accumulators (Placing on the Market) Regulations 2008, UK SI 2008/2164 as amended up to and including UK SI 2020/904	EN 50342-7:2015
Radio Equipment Regulations 2017, UK SI 2017/1206 as amended up to and including SI 2020/1112	IEC 62368-1:2014 CISPR 25:2016 ISO 11452-2:2004 ETSI EN 300 330 V2.1.1:2017

Risto Perttula
Director, Research and Development, Lynx
BRP Finland Oy

Rovaniemi, Finland

December 14th, 2022

skifoo LYNX BENSON EVIRUDE ROTAX CAN-AM

EU DECLARATION OF CONFORMITY



BRP Finland Oy
PL 8040 (Suomenkatu 7)
FI-06101 Rovaniemi, Finland
T 358 40 800 7700
F 358 16 318 114
www.brp.com

EU Declaration of Conformity

Authorized Representative: BRP Europe N.V., Skaldenstraat 125, Gent, Belgium, 9042

This declaration of conformity is issued under the sole responsibility of the manufacturer.

The undersigned, representing the manufacturer, hereby declares that model year **2024 Snowmobiles** marked with the **CE** mark and a 17-character vehicle identification number (VIN) structured as **YH2LxxxxRRxxxxxx** under commercial name **Lynx** comply with all the relevant provisions of the following Directives and Regulations:

Machinery Directive 2006/42/EC as amended up to and including Reg. 2019/1243/EU	ISO 12100:2010
Non-Road Mobile Machinery (NRMM) Regulation (EU) 2016/1628 on gaseous pollutants	Category SMB, Stage V emissions limits
Electromagnetic Compatibility (EMC) Directive 2014/30/EU as amended up to and including Reg. (EU) 2018/1139	CISPR 12:2007/A1:2009 & IEC 61000-6-1:2005 or UN R10.04 or later version
Battery Directive 2006/66/EC as amended up to and including Dir. (EU) 2018/849	EN 50342-7:2015
Radio Equipment (RED) Directive 2014/53/EU as amended up to and including Reg. 2018/1139 (If fitted with radio frequency (RF) D.E.S.S. key)	IEC 62368-1:2014 CISPR 25:2016 ISO 11452-2:2004 ETSI EN 300 330 V2.1.1:2017

Risto Perttula
Director, Research and Development, Lynx
BRP Finland Oy

Rovaniemi, Finland

December 14th, 2022

SKI-DOO LYNX SEBAGO EVARUDE ROTAX CAN-AM

RADIO FREQUENCY DIGITALLY ENCODED SECURITY SYSTEM (RF D.E.S.S. KEY)

This device complies with FCC Part 15 and Industry Canada license exempt RSS standard(s).

Operation is subject to the following two conditions: (1) this device may not cause interference, and (2) this device must accept any interference, including interference that may cause undesired operation of the device.

Changes or modifications not expressly approved by the party responsible for compliance could void the user's authority to operate the equipment.

IC Registration Number: 12006A-1001317030

FCC ID: 2ACER-1001317030

We, the party responsible for compliance, declare under our sole responsibility that the device is in conformity with the provisions of the following Council Directive: 2014/53/EU. To which this declaration relates is in conformity with the essential requirements and other relevant requirements. The product is in conformity with the following directives, harmonized standards and regulations:

Radio Equipment Directive (RED) 2014/53/EU and Harmonized Standards:

IEC 62368-1:2014, CISPR 25:2016, ISO 11452-2:2004, ETSI EN 300 330 V2.1.1:2017

Radio Equipment Statutory Instrument 2017/1206 and Designated Standards:

IEC 62368-1:2014, CISPR 25:2016, ISO 11452-2:2004, ETSI EN 300 330 V2.1.1:2017

MULTIFUNCTION GAUGE REGULATORY INFORMATION

Technical Information

Transmitter:

- BT operating frequency range: 2402 - 2480 MHz
- BT version: 4.2 (no BTLE)
- BT output power: < 8.5 dBm

Receiver:

- FM operating range: 76 - 108 MHz

Manufacturer and Address

Manufacturer:

- Robert Bosch LLC

Address:

- 38000 Hills Tech Drive,
Farmington Hills, MI 48331,
USA

To display the regulatory information on the vehicle digital display: From the home screen, access the main menu and keep the joystick pressed down for more than 10 seconds.

USA and Canada

This device complies with FCC Part 15 and Industry Canada license exempt RSS standard (s). Operation is subject to the following two conditions:

- (1) this device may not cause interference, and
- (2) this device must accept any interference, including interference that may cause undesired operation of the device.

Le présent appareil est conforme aux CNR d'Industrie Canada applicables aux appareils radio exempts de licence. L'exploitation est autorisée aux deux conditions suivantes:

- (1) l'appareil ne doit pas produire de brouillage, et
- (2) l'utilisateur de l'appareil doit accepter tout brouillage radioélectrique subi, même si le brouillage est susceptible d'en compromettre le fonctionnement.

Changes or modifications not expressly approved by the party responsible for compliance could void the user's authority to operate the equipment.

IC: 22868 - VDIBRHS01

FCC ID: 2AMJS - VDIBRHS01

RF exposure:

- The equipment complies with FCC RF exposure limits set forth for an uncontrolled environment.
- This equipment must be installed and operated with a separation distance of at least 20 cm from all persons.
- The antenna(s) used for this transmitter must not be co-located or operating in conjunction with any other antenna or transmitter.

Mexico

IFETEL

Marca: Robert Bosch LLC

Modelo(s): VIPHI2BT

Número: RCPBOVI18-0967

NOM-121-SCT1-2009

La operación de este equipo está sujeta a las siguientes dos condiciones: (1) es posible que este equipo o dispositivo no cause interferencia perjudicial y (2) este equipo o dispositivo debe aceptar cualquier interferencia, incluyendo la que pueda causar su operación no deseada.

Brazil



03473-18-04473

Este equipamento opera em caráter secundário, isto é, não tem direito a proteção contra interferência prejudicial, mesmo de estações do mesmo tipo, e não pode causar interferência a sistemas operando em caráter primário.

Japan

This device is granted pursuant to the Japanese Radio Law (電波法) and the Japanese Telecommunications Business Law (電気通信事業法). This device should not be modified (otherwise the granted designation number will become invalid).

Europe

Declaration of Conformity

Simplified EU Declaration of Conformity according Radio Equipment Directive 2014/53/EU.



DE

Hiermit erklärt Robert Bosch LLC, dass der Funkanlagentyp VIPHI2BT der Richtlinie 2014/53/EU entspricht. Der vollständige Text der EU-Konformitätserklärung ist unter der folgenden Internetadresse verfügbar: eu-doc.bosch.com

FR

Le soussigné, Robert Bosch LLC, déclare que l'équipement radioélectrique du type VIPHI2BT est conforme à la directive 2014/53/UE.

Le texte complet de la déclaration UE de conformité est disponible à l'adresse internet suivante: eu-doc.bosch.com

BG

С настоящото Robert Bosch LLC декларира, че този тип радиосъоръжение VIPHI2BT е в съответствие с Директива 2014/53/ЕО.

Цялостният текст на ЕС декларацията за съответствие може да се намери на следния интернет адрес: eu-doc.bosch.com

EL

Με την παρούσα ο/η Robert Bosch LLC, δηλώνει ότι ο ραδιοεξοπλισμός VIPHI2BT πληροί την οδηγία 2014/53/ΕΕ. Το πλήρες κείμενο της δήλωσης συμμόρφωσης ΕΕ διατίθεται στην ακόλουθη ιστοσελίδα στο διαδίκτυο: eu-doc.bosch.com

CS

Tímto Robert Bosch LLC prohlašuje, že typ rádiového zařízení VIPHI2BT je v souladu se směrnicí 2014/53/EU. Úplné znění EU prohlášení o shodě je k dispozici na této internetové adrese: eu-doc.bosch.com

DA

Hermed erklærer Robert Bosch LLC, at radioudstyrstypen VIPHI2BT er i overensstemmelse med direktiv 2014/53/EU.

EU-overensstemmelseserklæringens fulde tekst kan findes på følgende internetadresse: eu-doc.bosch.com

ET

Käesolevaga deklareerib Robert Bosch LLC, et käesolev raadioseadme tüüp VIPHI2BT vastab direktiivi 2014/53/EL nõuetele.

El'i vastavusdeklaratsiooni täielik tekst on kättesaadav järgmisel internetiaadressil: eu-doc.bosch.com

ES

Por la presente, Robert Bosch LLC declara que el tipo de equipo radioeléctrico VIPHI2BT es conforme con la Directiva 2014/53/UE.

El texto completo de la declaración UE de conformidad está disponible en la dirección Internet siguiente: eu-doc.bosch.com

FI

Robert Bosch LLC vakuuttaa, että radiolaitetyyppi VIPHI2BT on direktiivin 2014/53/EU mukainen.

EU-vaatimustenmukaisuusvakuutuksen täysimittainen teksti on saatavilla seuraavassa internetosoitteessa: eu-doc.bosch.com

EN

Hereby, Robert Bosch LLC declares that the radio equipment type VIPHI2BT is in compliance with Directive 2014/53/EU.

The full text of the EU declaration of conformity is available at the following internet address: eu-doc.bosch.com

HR

Robert Bosch LLC ovime izjavljuje da je radijska oprema tipa VIPHI2BT u skladu s Direktivom 2014/53/EU.

Cjeloviti tekst EU izjave o sukladnosti dostupan je na sljedećoj internetskoj adresi: eu-doc.bosch.com

HU

Robert Bosch LLC igazolja, hogy a VIPHI2BT típusú rádióberendezés megfelel a 2014/53/EU irányelvnek.

Az EU-megfelelőségi nyilatkozat teljes szövege elérhető a következő internetes címen: eu-doc.bosch.com

IT

Il fabbricante, Robert Bosch LLC, dichiara che il tipo di apparecchiatura radio VIPHI2BT è conforme alla direttiva 2014/53/UE.

Il testo completo della dichiarazione di conformità UE è disponibile al seguente indirizzo Internet: eu-doc.bosch.com

MULTIFUNCTION GAUGE REGULATORY INFORMATION

LT

Aš, Robert Bosch LLC, patvirtinu, kad radio įrenginių tipas VIPHI2BT atitinka Direktyvą 2014/53/ES.

Visas ES atitikties deklaracijos tekstas prieinamas šiuo interneto adresu: eu-doc.bosch.com

LV

Ar šo Robert Bosch LLC deklarē, ka radioiekārta VIPHI2BT atbilst Direktīvai 2014/53/ES.

Pilns ES atbilstības deklarācijas teksts ir pieejams šādā interneta vietnē: eu-doc.bosch.com

MT

B'dan, Robert Bosch LLC, niddikjara li dan it-tip ta' taghmir tar-radju VIPHI2BT huwa konformi mad-Direttiva 2014/53/UE.

It-test kollu tad-dikjarazzjoni ta' konformità tal-UE huwa disponibbli f'dan l-indirizz tal-Internet li ġej: eu.doc.bosch.com

NL

Hierbij verklaar ik, Robert Bosch LLC, dat het type radioapparatuur VIPHI2BT conform is met Richtlijn 2014/53/EU.

De volledige tekst van de EU-conformiteitsverklaring kan worden geraadpleegd op het volgende internetadres: eu.doc.bosch.com

PL

Robert Bosch LLC niniejszym oświadcza, że typ urządzenia radiowego VIPHI2BT jest zgodny z dyrektywą 2014/53/UE.

Pełny tekst deklaracji zgodności UE jest dostępny pod następującym adresem internetowym: eu-doc.bosch.com

PT

O(a) abaixo assinado(a) Robert Bosch LLC declara que o presente tipo de equipamento de rádio VIPHI2BT está em conformidade com a Diretiva 2014/53/UE.

O texto integral da declaração de conformidade está disponível no seguinte endereço de Internet: eu.doc.bosch.com

RO

Prin prezenta, Robert Bosch LLC declară că tipul de echipamente radio VIPHI2BT este în conformitate cu Directiva 2014/53/UE.

Textul integral al declarației UE de conformitate este disponibil la următoarea adresă internet: eu-doc.bosch.com

SV

Härmed försäkrar Robert Bosch LLC att denna typ av radioutrustning VIPHI2BT överensstämmer med direktiv 2014/53/EU.

Den fullständiga texten till EU-försäkran om överensstämmelse finns på följande webbadress: eu-doc.bosch.com

SL

Robert Bosch LLC potrjuje, da je tip radijske opreme VIPHI2BT skladen z Direktivo 2014/53/EU.

Celotno besedilo izjave EU o skladnosti je na voljo na naslednjem spletnem naslovu: eu-doc.bosch.com

SK

Robert Bosch LLC týmto vyhlasuje, že rádiové zariadenie typu VIPHI2BT je v súlade so smernicou 2014/53/EÚ.

Úplné EÚ vyhlásenie o zhode je k dispozícii na tejto internetovej adrese: eu-doc.bosch.com

IS

Robert Bosch LLC lýsir því hér með yfir að þráðlausí fjarskiptabúnaðurinn VIPHI2BT er í samræmi við tilskipun 2014/53/ESB.

Óstytta texta ESB-samræmisýfirlýsingarinnar er að finna á veffanginu: eu-doc.bosch.com

Liechtenstein

Hiermit erklärt Robert Bosch LLC, dass der Funkanlagentyp VIPHI2BT der Richtlinie 2014/53/EU entspricht.

Der vollständige Text der EU-Konformitätserklärung ist unter der folgenden Internetadresse verfügbar: eu.doc.bosch.com

NO

Hermed erklærer Robert Bosch LLC at radioustyrstypen VIPHI2BT er i samsvar med direktiv 2014/53/EU.

Hele teksten i EU-samsvarserklæringen finnes på følgende internettadresse: eu-doc.bosch.com

TECHNICAL SPECIFICATIONS

ENGINE

600 ACE

ENGINE	
Engine type	Rotax 600, liquid cooled, 4-stroke, D.O.H.C., dry sump.
Number of cylinder	2
Bore	74 mm (2.91 in)
Stroke	69.7 mm (2.74 in)
Displacement	600 cm ³ (36.6 in ³)
Maximum power engine speed	7250 RPM

FUEL SYSTEM		
Fuel delivery		Multi point EFI, 46 mm heated throttle body
Idle speed (not adjustable)	At ECO Mode	1500 ± 200 RPM
	STD/ Sport Mode	1700 ± 200 RPM

ELECTRICAL SYSTEM		
Total system output		30 A @ 14.5 V 520 W @ 6000 RPM
Spark plug	Type	NGK MR7BI-8 or equivalent
	Gap	Not adjustable 0.7 to 0.8 mm (.028 to .031 in)

LUBRICATION SYSTEM			
Engine oil	Type	Recom mended XPS oil	XPS 4T 0W40 Synthetic oil
		If XPS product is not available	Use a 0W40 4-stroke SAE synthetic engine oil meeting or exceeding the following lubricant industry specifications. Always check the API service label certification on the oil container, it must contain at least the indicated standard. – – API service classification SN
	Quantity	Oil change with filter: 2.1 l (2.22 qt (liq., US))	

900 ACE

ENGINE	
Engine type	Rotax 903, liquid cooled, 4-stroke, D.O.H.C., dry sump
Number of cylinder	3
Bore	74 mm (2.9 in)
Stroke	69.7 mm (2.74 in)

ENGINE

ENGINE	
Displacement	899 cm ³ (54.9 in ³)
Maximum power engine speed	7250 ± 200 RPM

FUEL SYSTEM		
Fuel delivery	Multi point EFI, 46 mm heated throttle body	
Idle speed (not adjustable)	Standard and ECO mode	1300 ± 200 RPM
	Sport mode	1500 ± 200 RPM

ELECTRICAL SYSTEM		
Total system output	30 A @ 14.5 V 650 W @ 6000 RPM	
Spark plug	Type	NGK MR8BI-8 or equivalent
	Gap	Not adjustable 0.7 to 0.8 mm (.028 to .031 in)

LUBRICATION SYSTEM			
Engine oil	Type	Recommended XPS oil	XPS 4T 0W40 Synthetic oil

LUBRICATION SYSTEM			
		If XPS product is not available	Use a 0W40 4-stroke SAE synthetic engine oil meeting or exceeding the following lubricant industry specifications. Always check the API service label certification on the oil container, it must contain at least the indicated standard. – – API service classification SN
	Quantity		Oil change with filter: 3.3 l (3.5 qt (liq.,US))

900 ACE Turbo

ENGINE	
Engine type	Rotax 903, liquid cooled, 4-stroke, D.O.H.C., dry sump, turbo without intercooler
Number of cylinder	3
Bore	74 mm (2.9 in)
Stroke	69.7 mm (2.74 in)
Displacement	899 cm ³ (54.9 in ³)
Maximum power engine speed	7400 ± 200 RPM

FUEL SYSTEM		
Fuel delivery		Multi point EFI, 46 mm heated throttle body
Idle speed (not adjustable)	Standard and ECO mode	1300 ± 200 RPM
	Sport mode	1500 ± 200 RPM

ELECTRICAL SYSTEM		
Total system output		30 A @ 14.5 V 650 W @ 6000 RPM
Spark plug	Type	NGK LMAR9AI-8D or equivalent
	Gap	Not adjustable 0.7 to 0.8 mm (.028 to .031 in)

LUBRICATION SYSTEM			
Engine oil	Type	Recom mended XPS oil	XPS 4T 0W40 Synthetic oil
		If XPS product is not available	Use a 0W40 4-stroke SAE synthetic engine oil meeting or exceeding the following lubricant industry specifications. Always check the API service label certification on the oil container, it must contain at least the indicated standard. – – API service classification SN

LUBRICATION SYSTEM		
	Quantity	Oil change with filter: 3.3 l (3.5 qt (liq.,US))

900 ACE Turbo R

ENGINE	
Engine type	Rotax 903, liquid cooled, 4-stroke, D.O.H.C., dry sump, turbo with intercooler
Number of cylinder	3
Bore	74 mm (2.9 in)
Stroke	69.7 mm (2.74 in)
Displacement	899 cm ³ (54.9 in ³)
Maximum power engine speed	7900 ± 200 RPM

FUEL SYSTEM		
Fuel delivery	Multi point EFI, 46 mm heated throttle body	
Idle speed (not adjustable)	Standard and ECO mode	1300 ± 200 RPM
	Sport mode	1650 ± 200 RPM

ELECTRICAL SYSTEM		
Total system output		30 A @ 14.5 V 650 W @ 6000 RPM
Spark plug	Type	NGK LMAR9AI-8D or equivalent
	Gap	Not adjustable 0.7 to 0.8 mm (.028 to .031 in)

LUBRICATION SYSTEM			
Engine oil	Type	Recom mended XPS oil	XPS 4T 0W40 Synthetic oil
		If XPS product is not available	Use a 0W40 4-stroke SAE synthetic engine oil meeting or exceeding the following lubricant industry specifications. Always check the API service label certification on the oil container, it must contain at least the indicated standard. – – API service classification SN
	Quantity		Oil change with filter: 3.3 l (3.5 qt (liq., US))

VEHICLE

49 Ranger

COOLING SYSTEM		
Coolant type	Recommended XPS coolant	XPS Extended life pre-mixed coolant
	If the recommended XPS product is not available	Ethyl glycol and distilled water (50%/50%) or coolant specifically formulated for aluminum engines
Coolant capacity	49 Ranger	6.9 l (7.3 qt (liq.,US))
	49 Ranger ST	7.2 l (7.6 qt (liq.,US))

FUEL SYSTEM			
Fuel pump			In-tank electrical
Fuel	Type	600 ACE 900 ACE	Regular unleaded gasoline (fuel which may contain up to 10% MAX ethanol)
	Octane rating		87 Pump Posted AKI (R+M)/2 92 RON
	Type	900 ACE Turbo	Premium unleaded gasoline (fuel which may contain up to 10% MAX ethanol)
	Octane rating		91 Pump Posted AKI (RON+MON)/2 95 RON
Fuel tank capacity			37 l (9.8 gal (liq.,US))

ELECTRICAL SYSTEM			
Battery		12 V, 18 A•h	
Headlamp		2 x 60/55 W (H-13)	
Taillight and stoplight		2 x 0.4/1.4 W LED	
Fuses	F1	Starter/Relays	5 A
	F2	Accessory	15 A
	F3	Taillight/Brake/ PAC	10 A
	F4	ECM/RFID/O2/ Sensor/CAPS	10 A
	F7	Fuel pump/ Engine	10 A
	F8	Cluster	15 A
	F9	Fan	15 A
	F10	Headlamps	20 A
Relays	RY 1	Main	-
	RY 2	Accessory	-
	RY 3	Fan	-
	RY 4	Lighting	-

DRIVE SYSTEM - CHAINCASE			
Chaincase oil (if equipped)	Type	Recommended	XPS Synthetic chaincase oil
		Alternative, or if not available	75W140 gear oil that meets the API GL-5 specification
	Capacity		550 ml (18.6 fl oz (US))

DRIVE SYSTEM - CHAINCASE		
Chain drive ratio	49 Ranger 600 ACE	21 / 53 / 116
	49 Ranger ST 900 ACE	21 / 49 / 114
	49 Ranger ST 900 ACE Turbo	24 / 49 / 116

DRIVE SYSTEM - PULLEYS		
Drive pulley type	600 ACE	eDrive II LC
	900 ACE	pDrive LD
	900 ACE Turbo	pDrive 4S
Drive pulley engagement RPM	600 ACE 900 ACE	2200 ± 100 RPM
	900 ACE Turbo	2100 ± 100 RPM
Driven pulley type	600 ACE 900 ACE	QRS-4S
	900 ACE Turbo	QRS-4S-VENT

DRIVE SYSTEM - TRACK			
Drive sprocket number of teeth		8	
Track	Width	40.6 cm (16 in)	
	Length	392.3 cm (154.4 in)	
Track	Profile height	49 Ranger	39 mm (1.54 in)
		49 Ranger ST	50 mm (2.0 in)

DRIVE SYSTEM - TRACK		
Track adjustment	Deflection	32 mm (1.26 in)
	Force	7.3 kgf (16 lbf)

BRAKE SYSTEM		
Brake	Type	Single 200 mm cross drilled carbon steel disc
Brake fluid	Type	DOT 4
	Quantity	65 ml (2.2 fl oz (US))
Caliper		Fixed twin pistons (2 x 40mm)
Brake pad material		Organic
Minimum brake pad thickness (includes backing plate)		5 mm (.2 in)
Minimum brake disc thickness		4.5 mm (.177 in)
Maximum brake disc warpage		0.25 mm (.01 in)

FRONT SUSPENSION		
Suspension type	49 Ranger ST	LFS X
	49 Ranger	LFS X with bended lower A-arms
Suspension maximum travel	49 Ranger	215 mm (8.5 in)
	49 Ranger ST	221 mm (8.7 in)

FRONT SUSPENSION	
Shock absorber type	HPG 36
Stabilizer bar type	Link

REAR SUSPENSION	
Suspension type	EasyRide
Suspension maximum travel	340 mm (13.4 in)
Shock absorber type	Center
	Rear
	HPG 36
	HPG 36

WEIGHT AND DIMENSIONS		
Mass (dry)	49 Ranger 600 ACE	248 kg (546.7 lb)
	49 Ranger ST 900 ACE	270 kg (594 lb)
	49 Ranger ST 900 ACE Turbo	277 kg (609.4 lb)
Overall length (without snowflap)	All models	336 cm (132.3 in)
Overall width	49 Ranger ST	120 cm (47.2 in)
	49 Ranger ST	128 cm (50.4 in)
	49 Ranger ST	147 cm (57.9 in)
	49 Ranger	154 cm (60.6 in)

WEIGHT AND DIMENSIONS		
Ski Stance	49 Ranger	97.5 to 101.7 cm (38.4 to 40 in)
	49 Ranger ST	108 cm (42.5 in)

59 Ranger

COOLING SYSTEM		
Coolant type	Recommended XPS coolant	XPS Extended life pre-mixed coolant
	If the recommended product is not available	Ethyl glycol and distilled water (50%/50%) or coolant specifically formulated for aluminum engines
Coolant capacity		6.9 l (7.3 qt (liq.,US))

FUEL SYSTEM		
Fuel pump		In-tank electrical
Fuel	Type	Regular unleaded gasoline (fuel which may contain up to 10% MAX ethanol)
	Octane rating	87 Pump Posted AKI (R+M)/2) 92 RON
Fuel tank capacity		42 l (11.1 gal (liq.,US))

ELECTRICAL SYSTEM			
Battery		12 V, 18 A•h	
Headlamp		2 x 60/55 W (H-13)	
Taillight and stoplight		2 x 0.4/1.4 W LED	
Fuses	F1	Clock/Starter/ Relays	5 A
	F2	Headlamps	20 A
	F3	Taillight/Brake/ PAC	10 A
	F4	ECM/RFID/O2/ Sensor/CAPS	10 A
	F5	Fuel pump/ Starter	10 A
	F6	Fan	15A
	F7	Accessory	15 A
	F8	Cluster	15 A
	F10	RER	30 A
	Relays	RY 1	Main
RY 2		Forward	-
RY 3		Fan	-
RY 4		Reverse	-
RY 5		Accessory	-
RY 6		Lighting	-

DRIVE SYSTEM - GEARBOX			
Gearbox oil	Type	Recommended XPS oil	XPS Synchronmesh Transmission Synthetic Oil or equivalent.
		If the recommended product is not available	75W140 gear oil that meets the API GL-5 specification
	Capacity		700 ml (23.7 fl oz(US))
Chain drive ratio			21 / 51 / 100
Gearbox ratio	Low		4.81 : 1
	High		2.66 : 1

DRIVE SYSTEM - PULLEYS	
Drive pulley type	eDrive II LC
Drive pulley engagement RPM	2200 ± 100 RPM
Driven pulley type	QRS-4S

DRIVE SYSTEM - TRACK		
Drive sprocket number of teeth		8
Track	Width	50 cm (20 in)
	Length	392.3 cm (154.4 in)
	Profile height	44 mm (1.75 in)
Track adjustment	Deflection	32 mm (1.26 in)

DRIVE SYSTEM - TRACK		
	Force	7.3 kgf (16 lbf)

BRAKE SYSTEM		
Brake	Type	Single 200 mm cross drilled carbon steel disc
Brake fluid	Type	DOT 4
	Quantity	65 ml (2.2 fl oz (US))
Caliper	Fixed twin pistons (2 x 40mm)	
Brake pad material	Organic	
Minimum brake pad thickness (includes backing plate)	5 mm (.2 in)	
Minimum brake disc thickness	4.5 mm (.177 in)	
Maximum brake disc warpage	0.25 mm (.01 in)	

FRONT SUSPENSION	
Suspension type	LFS X
Suspension maximum travel	210 mm (8.3 in)
Shock absorber type	HPG 36

REAR SUSPENSION		
Suspension type		EasyRide
Suspension maximum travel		340 mm (13.4 in)
Shock absorber type	Center	HPG 36
	Rear	HPG 36

WEIGHT AND DIMENSIONS	
Mass (dry)	265 kg (584 lb)
Overall length (without snowflap)	324 cm (127.6 in)
Overall width	120 cm (47.2 in)
Overall height	150 cm (59 in)
Ski Stance	97.5 to 101.7 cm (38.4 to 40 in)

69 Ranger

COOLING SYSTEM		
Coolant type	Recommended XPS coolant	XPS Extended life pre-mixed coolant
	If the XPS product is not available	Ethyl glycol and distilled water (50%/50%) or coolant specifically formulated for aluminum engines
Coolant capacity	900 ACE	7.0 l (7.4 qt (liq.,US))

COOLING SYSTEM		
	900 ACE Turbo 900 ACE Turbo R	7.2 l (7.5 qt (liq.,US))

FUEL SYSTEM			
Fuel pump			In-tank electrical
Fuel	Type	900 ACE	Regular unleaded gasoline (fuel which may contain up to 10% MAX ethanol)
	Octane rating		87 Pump Posted AKI (R+M)/2 92 RON
	Type	900 ACE Turbo 900 ACE Turbo R	Premium unleaded gasoline (fuel which may contain up to 10% MAX ethanol)
	Octane rating		91 Pump Posted AKI (RON+MON)/2 95 RON
Fuel tank capacity			42 l (11.1 gal (liq.,US))

ELECTRICAL SYSTEM			
Battery		All except SnowCruiser	12 V, 18 A•h
		SnowCruiser	12 V, 30 A•h
Headlamp			2 x 60/55 W (H-13)
Taillight and stoplight			2 x 0.4/1.4 W LED
Fuses	F1	Clock/Starter/ Relays	5 A

ELECTRICAL SYSTEM			
	F2	Headlamps	20 A
	F3	Taillight/Brake/ PAC	10 A
	F4	ECM/RFID/O2/ Sensor/CAPS	10 A
	F5	Fuel pump/ Starter	10 A
	F6	Fan	15A
	F7	Accessory	15 A
	F8	Cluster	15 A
	F10	RER	30 A
Relays	RY 1	Main	-
	RY 2	Forward	-
	RY 3	Fan	-
	RY 4	Reverse	-
	RY 5	Accessory	-
	RY 6	Lighting	-

DRIVE SYSTEM - GEARBOX			
Gearbox oil	Type	Recommended XPS oil	XPS Synchronmesh Transmission Synthetic Oil or equivalent.
		If the XPS product is not available	75W140 gear oil that meets the API GL-5 specification
	Capacity		700 ml (23.7 fl oz (US))

DRIVE SYSTEM - GEARBOX			
Chain drive ratio		900 ACE	21 / 51 / 100
		900 ACE Turbo	23 / 51 / 102
		900 ACE Turbo R	25 / 51 / 102
Gearbox ratio	Low	900 ACE	4.81 : 1
	High		2.66 : 1
	Low	900 ACE Turbo	3.88 : 1
	High		2.14 : 1
	Low	900 ACE Turbo R	3.89 : 1
	High		2.15 : 1

DRIVE SYSTEM - PULLEYS			
Drive pulley type		900 ACE	pDrive LD
		900 ACE Turbo	pDrive 4S
		900 ACE Turbo R	pDrive 4S PLUS
Drive pulley engagement RPM		900 ACE	2200 ± 100 RPM
		900 ACE Turbo 900 ACE Turbo R	2100 ± 100 RPM
Driven pulley type		900 ACE	QRS-4S
		900 ACE Turbo 900 ACE Turbo R	QRS-4S-VENT

DRIVE SYSTEM - TRACK		
Drive sprocket number of teeth		8
Track	Width	60 cm (24 in)
	Length	392.3 cm (154.4 in)
	Profile height	38 mm (1.5 in)
Track adjustment	Deflection	32 mm (1.26 in)
	Force	7.3 kgf (16 lbf)

BRAKE SYSTEM		
Brake	Type	Single 200 mm cross drilled carbon steel disc
Brake fluid	Type	DOT 4
	Quantity	65 ml (2.2 fl oz (US))
Caliper		Fixed twin pistons (2 x 40mm)
Brake pad material		Organic
Minimum brake pad thickness (includes backing plate)		5 mm (.2 in)
Minimum brake disc thickness		4.5 mm (.177 in)
Maximum brake disc warpage		0.25 mm (.01 in)

FRONT SUSPENSION		
Suspension type	SnowCruiser	LFS X
	All other 69 Ranger	LFS X with bended lower A-arms
Suspension maximum travel		257 mm (10.1 in)
Shock absorber type	SnowCruiser	KYB 36 R
	All other 69 Ranger	HPG 36

REAR SUSPENSION			
Suspension type			EasyRide
Suspension maximum travel			340 mm (13.4 in)
Shock absorber type	Center	SnowCruiser	KYB 46 Kashima coated
		All other 69 Ranger	HPG 36
	Rear	SnowCruiser	KYB 46 Kashima coated
		All other 69 Ranger	HPG 36

WEIGHT AND DIMENSIONS		
Mass (dry)	69 Ranger	292 kg (643.7 lb)
	69 Ranger Limited	327 kg (720.9 lb)
	69 Ranger SnowCruiser	315 kg (694.5 lb)

WEIGHT AND DIMENSIONS		
Overall length (without snowflap)		324 cm (127.6 in)
Overall width	69 Ranger 69 Ranger Limited	120 cm (47.2 in)
	69 Ranger SnowCruiser	128 cm (50.4 in)
Overall height	69 Ranger 69 Ranger Limited	150 cm (59 in)
	69 Ranger SnowCruiser	147 cm (57.9 in)
Ski Stance	69 Ranger 69 Ranger Limited	97.5 to 101.7 cm (38.4 to 40 in)
	69 Ranger SnowCruiser	108 cm (42.5 in)

TROUBLESHOOT- ING

TROUBLESHOOTING- GUIDELINES

1. ELECTRIC STARTER DOES NOT WORK

Emergency engine stop switch in OFF position or tether cord cap not installed on engine cut-off switch.

- *Place the emergency engine stop switch in the ON position and install tether cord cap (on engine cut-off switch).*

Throttle applied while attempting an engine start.

- *Release throttle while cranking.*

2. ENGINE IS CRANKED BUT FAILS TO START

No fuel to the engine.

- *Check fuel tank level, add fuel if necessary.*

System voltage too low.

- *Contact an authorized BRP snowmobile dealer.*

3. ENGINE RPM DOES NOT REACH CLUTCH ENGAGEMENT POINT

D.E.S.S. did not read D.E.S.S. key code in the tether cord cap.

- *Properly install tether cord cap.*

D.E.S.S. has read a different code than the one programmed.

- *Install a tether cord cap for which this snowmobile was programmed.*

ECM does not recognize the D.E.S.S. key.

- *Refer to an authorized BRP snowmobile dealer.*

4. ENGINE LACKS ACCELERATION OR POWER

Engine warm-up in progress.

- *Drive vehicle at low speeds for a few minutes.*

Engine break-in period not completed.

- *Complete break-in period.*

Drive and driven pulleys require servicing.

- *Contact an authorized BRP snowmobile dealer.*

Engine overheats.

- *Check coolant level, see Maintenance Procedures.*
- *Check heat exchangers cleanliness. Clean if necessary.*

Drive belt worn too thin.

- *If the drive belt has lost more than 3 mm (1/8 in) of its original width, it will affect vehicle performance.*
- *Replace drive belt.*

Incorrect track adjustment.

- *See Maintenance Procedures and/or an authorized BRP snowmobile dealer for proper alignment and tension adjustments.*

Fuel pressure too low.

- *Seek service from an authorized BRP snowmobile dealer, repair shop, or person of your own choosing for maintenance, repair, or replacement. Please refer to the US EPA EMISSION-RELATED WARRANTY contained herein for information about warranty claims.*

5. ENGINE BACKFIRES

Engine is running too hot.

- *See item 4 of ENGINE LACKS POWER.*

Ignition timing is incorrect or there is an ignition system failure.

- *Seek service from an authorized BRP snowmobile dealer, repair shop, or person of your own choosing for maintenance, repair, or replacement. Please refer to the US EPA EMISSION-RELATED WARRANTY contained herein for information about warranty claims.*

Exhaust system leak.

- *Seek service from an authorized BRP snowmobile dealer, repair shop, or person of your own choosing for maintenance, repair, or replacement. Please refer to the US EPA EMISSION-RELATED WARRANTY contained herein for information about warranty claims.*

Fuel pressure too low.

- *Seek service from an authorized BRP snowmobile dealer, repair shop, or person of your own choosing for maintenance, repair, or*

replacement. Please refer to the US EPA EMISSION-RELATED WARRANTY contained herein for information about warranty claims.

6. ENGINE MISFIRES

Water in fuel.

- *Drain fuel system and refill with fresh fuel.*

7. HEATED GRIPS/THUMB WARMERS ARE NOT WORKING

Engine RPM is too low.

- *Make sure engine RPM is above 2000.*

8. ENGINE HAS SHUT DOWN

The engine shuts down after long periods of idling.

- *Do not let engine idle too long. Refer to Vehicle Warm-up in Operating Instruction.*

MONITORING SYSTEM

Pilot Lamps, Messages and Beeper Codes

Gauge pilot lamp(s) will inform you if an anomaly occurs or to inform you of a particular condition.



TYPICAL — PILOT LAMPS

Pilot lamp can flash alone or in combination with another lamp.

The lower display is used as a complement of the pilot lamps to give you a brief description if an anomaly occurs or to inform you of a particular condition.

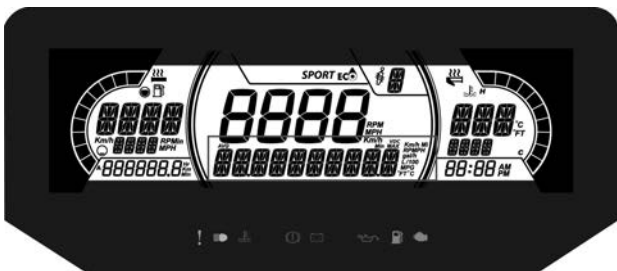

7.2" DIGITAL LOWER DISPLAY

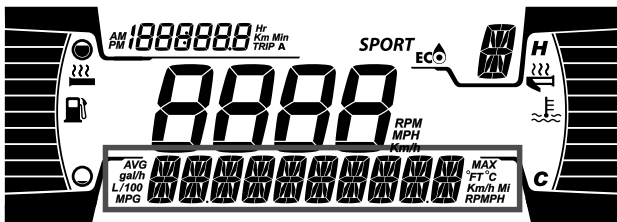

4.5" DIGITAL LOWER DISPLAY



Messages will be displayed with a beep code and pilot lamp(s).



Beeper codes will be heard and messages will be displayed to catch your attention.

See table below for details.

NOTE:

Some of the listed pilot lamps and messages do not apply to all models.

Pilot lamp ON	Beeper	Message display	Description
	1 Long beep repeating	HIGH ENGINE TEMPERATURE	Engine is overheating, reduce snowmobile speed and run in loose snow or stop engine immediately and let engine cool down. Check coolant level, refer to <i>Maintenance</i> . If coolant level is correct and overheating persists, contact an authorized BRP snowmobile dealer. Do not run the engine if condition persists.
		MUFFLER OVERHEAT	Reduce speed or stop engine. Let engine cool down and restart. If overheating persists, contact an authorized BRP snowmobile dealer. Do not run the engine if condition persists.
	1 Long beep repeating	HIGH ENGINE TEMPERATURE	Critical overheat. Stop engine immediately and let engine cool down. Check coolant level, refer to <i>Maintenance</i> . If coolant level is correct and overheating persists, contact an authorized BRP snowmobile dealer. Do

Pilot lamp ON	Beeper	Message display	Description
			not run the engine if condition persists.
		MUFFLER OVERHEAT	Critical overheat. Stop engine immediately and let engine cool down. If overheating persists, contact an authorized BRP snowmobile dealer. Do not run the engine if condition persists.
		ECM OVERHEAT	
	—	BATT VOLT	Indicate a low or high battery voltage condition. See an authorized BRP snowmobile dealer as soon as possible.
	1 Long beep repeating	CHECK ENGINE	Engine fault, see an authorized BRP snowmobile dealer, repair shop or person of your own choosing as soon as possible.
	—	—	Displayed when brake is applied for more than 15 seconds while throttle lever is squeezed and vehicle is moving at more than 5 km/h (3 MPH).
—	4 short beeps every 5 minutes	KNOCK	Engine detonation (RPM is limited when this condition occurs).

Pilot lamp ON	Beeper	Message display	Description
			<ul style="list-style-type: none"> - Ensure recommended fuel is used. - Check fuel quality, replace if necessary. - If fault still occurs, contact an authorized BRP snowmobile dealer, repair shop, or person of your own choosing.
—	4 short beeps every 5 minutes	REV LIMIT	Engine RPM limited for protection when certain faults occur.
—	—	OVER REV	Indicates that maximum engine RPM is reached. Check clutch calibration.
—	Short beeps repeating rapidly	SHUTDOWN	Shutdown procedure in force due to engine overheating or fuel pump problem.
DESS	—	—	Good key, vehicle ready to operate.
	—	WRONG KEY	Unable to read key (bad connection). Make sure the key is clean and correctly snapped on post.

Pilot lamp ON	Beeper	Message display	Description
	—	CHECK KEY	Invalid key or key not programmed. Use the proper key for the vehicle or have the programmed.
 (blinking)	—	—	Fuel level sensor problem.

Fault Codes

The fault codes can be displayed on the center display.

The fault codes are accessible in the setting menu.

Contact an authorized BRP snowmobile dealer for code signification.

This page is intentionally blank

WARRANTY

BRP INTERNATIONAL LIMITED WARRANTY: 2024 LYNX® SNOWMOBILES

SCOPE OF THE LIMITED WARRANTY

Bombardier Recreational Products Inc. ("BRP") warrants its 2024 LYNX snowmobiles sold by distributors or dealers authorized by BRP to distribute LYNX snowmobiles ("LYNX Distributor / Dealer") outside of the fifty United States, Canada, members of the European Economic Area (which is comprised of the member states of the European Union plus United Kingdom, Norway, Iceland and Liechtenstein) ("EEA"), members states of the Commonwealth of the Independent States (including Ukraine and Turkmenistan) ("CIS") and Turkey, from defects in material or workmanship for the period and under the conditions described below.

Non-factory installed parts and accessories are not covered under this limited warranty. Please refer to the applicable parts and accessories limited warranty text.

This limited warranty will become null and void if: (1) the snowmobile was used for racing or any other competitive activity, at any point, even by a previous owner; or (2) the snowmobile has been altered or modified in such a way so as to adversely affect its operation, performance or durability, or has been altered or modified to change its intended use.

LIMITATIONS OF LIABILITY

TO THE EXTENT PERMITTED BY LAW, THIS WARRANTY IS EXPRESSLY GIVEN AND ACCEPTED IN LIEU OF ANY AND ALL OTHER WARRANTIES, EXPRESSED OR IMPLIED, INCLUDING WITHOUT LIMITATION ANY WARRANTY OF MERCHANTABILITY OR FITNESS FOR A PARTICULAR PURPOSE. TO THE EXTENT THAT THEY CANNOT BE DISCLAIMED, THE IMPLIED WARRANTIES ARE LIMITED IN DURATION TO THE LIFE OF THE EXPRESS WARRANTY. INCIDENTAL AND CONSEQUENTIAL DAMAGES ARE EXCLUDED FROM COVERAGE UNDER THIS WARRANTY. SOME JURISDICTIONS DO NOT ALLOW FOR THE DISCLAIMERS, LIMITATIONS AND EXCLUSIONS IDENTIFIED ABOVE. AS A RESULT, THEY MAY NOT APPLY TO YOU. THIS WARRANTY GIVES YOU SPECIFIC RIGHTS, AND YOU MAY ALSO HAVE OTHER LEGAL RIGHTS WHICH MAY VARY FROM COUNTRY TO COUNTRY. BRP SHALL NOT BE HELD LIABLE IF PRODUCTS OR WARRANTY PARTS ARE NOT AVAILABLE IN CERTAIN COUNTRIES FOR REASONS OUTSIDE OF BRP'S CONTROL. (FOR PRODUCTS PURCHASED IN AUSTRALIA REFER TO "FOR PRODUCTS SOLD IN AUSTRALIA ONLY", BELOW).

Neither the LYNX Distributor / Dealer nor any other person has been authorized to make any affirmation, representation or warranty

regarding the product, other than those contained in this limited warranty, and if made, shall not be enforceable against BRP.

BRP reserves the right to modify this warranty at any time, being understood that such modification will not alter the warranty conditions applicable to the products sold while this warranty is in effect.

EXCLUSIONS – ARE NOT WARRANTED

The following are not warranted under this limited warranty under any circumstances:

- Normal wear and tear;
- Routine maintenance items, tune ups, adjustments;
- Damage caused by negligence or failure to provide proper maintenance and/or storage, as described in the operator's guide;
- Damage resulting from removal of parts, improper repairs, service, maintenance, modifications or use of parts or accessories not manufactured or approved by BRP which in its reasonable judgment are either incompatible with the product or adversely affect its operation, performance and durability, or resulting from repairs done by a person that is not an authorized servicing BRP snowmobile distributor/ dealer;
- Damage caused by abuse, abnormal use, neglect, racing or operation of the product on surfaces other than snow, or operation of the product in a manner inconsistent with the recommended operation described in the Operator's Guide;
- Damage resulting from accident, submersion, fire, snow or water ingestion, theft, vandalism or any act of God;
- Operation with fuels, oils or lubricants which are not suitable for use with the product (see the Operator's Guide);
- Damage resulting from rust, corrosion or exposure to the elements;
- Incidental or consequential damages, or damages of any kind including without limitation towing, storage, transportation expenses, telephone, rental, taxi, inconvenience, insurance coverage, loan payments, loss of time, loss of income; or time missed for downtime experience due to service work.
- And damage resulting from studs installed on tracks if the installation does not conform to BRP's instructions.

WARRANTY COVERAGE PERIOD

This warranty will be in effect from (1) the date of delivery to the first retail consumer or (2) the date the product is first put into use, whichever occurs first and for a period of:

TWELVE (12) CONSECUTIVE MONTHS, for private or commercial use owners. However, the warranty coverage period on a snowmobile

delivered between June 1st and December 1st of a given year will expire November 30th of the following year.

The repair or replacement of parts or the performance of service under this warranty does not extend the life of this warranty beyond its original expiration date.

Note that the duration and any other modalities of the warranty coverage are subject to the applicable national or local legislation in the customer's country.

FOR PRODUCTS SOLD IN AUSTRALIA ONLY

Nothing in these Warranty terms and conditions should be taken to exclude, restrict or modify the application of any condition, warranty, guarantee, right or remedy conferred or implied under the Competition and Consumer Act 2010 (Cth), including the Australian Consumer Law or any other law, where to do so would contravene that law, or cause any part of these terms and conditions to be void. The benefits given to you under this limited warranty are in addition to other rights and remedies that you have under Australian law.

Our goods come with guarantees that cannot be excluded under the Australian Consumer Law. You are entitled to a replacement or refund for a major failure and for compensation for any other reasonably foreseeable loss or damage. You are also entitled to have the goods repaired or replaced if the goods fail to be of acceptable quality and the failure does not amount to a major failure.

CONDITIONS TO HAVE WARRANTY COVERAGE

This warranty coverage is available **only** if each of the following conditions has been fulfilled:

- The 2024 LYNX snowmobile must be purchased as new and unused by its first owner from a LYNX Distributor / Dealer authorized to distribute LYNX snowmobiles in the country in which the sale occurred;
- The BRP specified pre-delivery inspection process must be completed and documented;
- The product must have undergone proper registration by an authorized LYNX Distributor / Dealer;
- The 2024 LYNX snowmobile must be purchased in the country in which the purchaser resides.
- Routine maintenance outlined in the operator's guide must be timely performed in order to maintain warranty coverage. BRP reserves the right to make warranty coverage contingent upon proof of proper maintenance.

BRP will not honour this limited warranty to any private use owner or commercial use owner if one of the preceding conditions has not been

met. Such limitations are necessary in order to allow BRP to preserve both the safety of its products, and also that of its consumers and the general public.

WHAT TO DO TO OBTAIN WARRANTY COVERAGE

The customer must cease using the snowmobile upon the appearance of an anomaly. The customer must notify a servicing LYNX Distributor / Dealer within two (2) days of the appearance of a defect, and provide it with reasonable access to the product and reasonable opportunity to repair it. The customer must also present to the authorized LYNX Distributor / Dealer, proof of purchase of the product and must sign the repair / work order prior to starting the repair in order to validate the warranty repair. All parts replaced under this limited warranty become the property of BRP.

Note that the notification period is subject to the applicable national or local legislation in customer's country.

WHAT BRP WILL DO

To the extent permitted by law, BRP's obligations under this warranty are limited to, at its sole discretion, repairing parts found defective under normal use, maintenance and service, or replacing such parts without charge for parts and labour, at any authorized LYNX Distributor / Dealer during the warranty coverage period under the conditions described herein. BRP's responsibility is limited to making the required repairs or replacements of parts. No claim of breach of warranty shall be cause for cancellation or rescission of the sale of the snowmobile to the owner. You may have other legal rights which may vary from country to country.

In the event that service is required outside of the country of original sale, the owner will bear responsibility for any additional charges due to local practices and conditions, such as, but not limited to, freight, insurance, taxes, license fees, import duties, and any and all other financial charges, including those levied by governments, states, territories and their respective agencies.

BRP reserves the right to improve or modify products from time to time without assuming any obligation to modify products previously manufactured.

TRANSFER

If the ownership of a product is transferred during the warranty coverage period, this limited warranty, subject to its terms and conditions, shall also be transferred and be valid for the remaining coverage period provided BRP or an authorized LYNX Distributor / Dealer receives

a proof that the former owner agreed to the transfer of ownership, in addition to the coordinates of the new owner.

CONSUMER ASSISTANCE

In the event of a controversy or a dispute in connection with this limited warranty, BRP suggests that you try to resolve the issue at the LYNX Distributor / Dealer level. We recommend discussing the issue with the authorized LYNX Distributor / Dealer's service manager or owner.

If the matter still remains unresolved, contact BRP by filling out the customer contact form at www.brp.com or contact BRP by mail at one of the addresses listed under the *CONTACT US* section of this guide.

BRP LIMITED WARRANTY FOR THE EUROPEAN ECONOMIC AND THE COMMONWEALTH OF THE INDEPENDENT STATES (CIS) AREAS AND TURKEY: 2024 LYNX® SNOWMOBILES

SCOPE OF THE LIMITED WARRANTY

Bombardier Recreational Products Inc. ("BRP") warrants its 2024 LYNX snowmobiles sold by distributors or dealers authorized by BRP to distribute LYNX snowmobiles ("LYNX Distributor / Dealer") in member states of the European Economic Area (which is comprised of the member states of the European Union plus the United Kingdom, Norway, Iceland and Liechtenstein) ("EEA"), in member states of the Commonwealth of the Independent States (including Ukraine and Turkmenistan) ("CIS") and Turkey from defects in material or workmanship for the period and under the conditions described below.

Non-factory installed parts and accessories are not covered under this limited warranty. Please refer to the applicable parts and accessories limited warranty text.

This limited warranty will become null and void if: (1) the snowmobile was used for racing or any other competitive activity, at any point, even by a previous owner; or (2) the snowmobile has been altered or modified in such a way so as to adversely affect its operation, performance or durability, or has been altered or modified to change its intended use.

LIMITATIONS OF LIABILITY

TO THE EXTENT PERMITTED BY LAW, THIS WARRANTY IS EXPRESSLY GIVEN AND ACCEPTED IN LIEU OF ANY AND ALL OTHER WARRANTIES, EXPRESSED OR IMPLIED, INCLUDING WITHOUT LIMITATION ANY WARRANTY OF MERCHANTABILITY OR FITNESS FOR A PARTICULAR PURPOSE. TO THE EXTENT THAT THEY CANNOT BE DISCLAIMED, THE IMPLIED WARRANTIES ARE LIMITED IN DURATION TO THE LIFE OF THE EXPRESS WARRANTIES. INCIDENTAL AND CONSEQUENTIAL DAMAGES ARE EXCLUDED FROM COVERAGE UNDER THIS WARRANTY. SOME JURISDICTIONS DO NOT ALLOW FOR THE DISCLAIMERS, LIMITATIONS AND EXCLUSIONS IDENTIFIED ABOVE. AS A RESULT, THEY MAY NOT APPLY TO YOU. THIS WARRANTY GIVES YOU SPECIFIC RIGHTS, AND YOU MAY ALSO HAVE OTHER LEGAL RIGHTS WHICH MAY VARY FROM COUNTRY TO COUNTRY. BRP SHALL NOT BE HELD LIABLE IF PRODUCTS OR WARRANTY PARTS ARE NOT AVAILABLE IN CERTAIN COUNTRIES FOR REASONS OUTSIDE OF BRP'S CONTROL.

Neither the LYNX Distributor / Dealer nor any other person has been authorized to make any affirmation, representation or warranty regarding the product, other than those contained in this limited warranty, and if made, shall not be enforceable against BRP.

BRP reserves the right to modify this warranty at any time, being understood that such modification will not alter the warranty conditions applicable to the products sold while this warranty is in effect.

EXCLUSIONS – ARE NOT WARRANTED

The following are not warranted under this limited warranty under any circumstances:

- Normal wear and tear;
- Routine maintenance items, tune ups, adjustments;
- Damage caused by negligence or failure to provide proper maintenance and/or storage, as described in the operator's guide;
- Damage resulting from removal of parts, improper repairs, service, maintenance, modifications or use of parts or accessories not manufactured or approved by BRP which in its reasonable judgment are either incompatible with the product or adversely affect its operation, performance and durability, or resulting from repairs done by a person that is not an authorized servicing BRP snowmobile distributor/ dealer;
- Damage caused by abuse, abnormal use, neglect, racing or operation of the product on surfaces other than snow, or operation of the product in a manner inconsistent with the recommended operation described in the Operator's Guide;
- Damage resulting from accident, submersion, fire, snow or water ingestion, theft, vandalism or any act of God;
- Operation with fuels, oils or lubricants which are not suitable for use with the product (see the Operator's Guide);
- Damage resulting from rust, corrosion or exposure to the elements;
- Incidental or consequential damages, or damages of any kind including without limitation towing, storage, transportation expenses, telephone, rental, taxi, inconvenience, insurance coverage, loan payments, loss of time, loss of income; or time missed for downtime experience due to service work.
- And damage resulting from studs installed on tracks if the installation does not conform to BRP's instructions.

WARRANTY COVERAGE PERIOD

This warranty will be in effect from (1) the date of delivery to the first retail consumer or (2) the date the product is first put into use, whichever occurs first and for a period of:

TWENTY-FOUR (24) CONSECUTIVE MONTHS, for private use owners and TWELVE (12) CONSECUTIVE MONTHS for commercial use owners. However, the warranty coverage period on a snowmobile delivered between June 1st and December 1st of a given year will expire November 30th of the applicable year. A snowmobile is used commercially when it is used in connection with generating income or any work or employment during any part of the warranty period. A snowmobile is also used commercially when, at any point during the warranty period, it has commercial tags or is licensed for commercial use.

The repair or replacement of parts or the performance of service under this warranty does not extend the life of this warranty beyond its original expiration date.

Note that the duration and any other modalities of the warranty coverage are subject to the applicable national or local legislation in the customer's country.

CONDITIONS TO HAVE WARRANTY COVERAGE

This warranty coverage is available **only** if each of the following conditions has been fulfilled:

- The 2024 LYNX snowmobile must be purchased as new and unused by its first owner from a LYNX Distributor / Dealer authorized to distribute LYNX products in the country in which the sale occurred;
- The BRP specified pre-delivery inspection process must be completed and documented;
- The product must have undergone proper registration by an authorized LYNX Distributor / Dealer;
- The 2024 LYNX snowmobile must be purchased in the country (or in the case of the EEA, union of countries) in which the purchaser resides; and
- Routine maintenance outlined in the operator's guide must be timely performed in order to maintain warranty coverage. BRP reserves the right to make warranty coverage contingent upon proof of proper maintenance.

BRP will not honour this limited warranty to any private use owner or commercial use owner if one of the preceding conditions has not been met. Such limitations are necessary in order to allow BRP to preserve both the safety of its products, and also that of its consumers and the general public.

WHAT TO DO TO OBTAIN WARRANTY COVERAGE

The customer must cease using the snowmobile upon the appearance of an anomaly. The customer must notify a servicing LYNX Distributor

/ Dealer within two (2) months of the appearance of a defect, and provide it with reasonable access to the product and reasonable opportunity to repair it. The customer must also present to the authorized LYNX Distributor / Dealer, proof of purchase of the product and must sign the repair / work order prior to starting the repair in order to validate the warranty repair. All parts replaced under this limited warranty become the property of BRP.

Note that the notification period is subject to the applicable national or local legislation in customer's country.

WHAT BRP WILL DO

To the extent permitted by law, BRP's obligations under this warranty are limited to, at its sole discretion, repairing parts found defective under normal use, maintenance and service, or replacing such parts without charge for parts and labour, at any authorized LYNX Distributor / Dealer during the warranty coverage period under the conditions described herein. BRP's responsibility is limited to making the required repairs or replacements of parts. No claim of breach of warranty shall be cause for cancellation or rescission of the sale of the snowmobile to the owner. You may have other legal rights which may vary from country to country.

In the event that service is required outside of the country of original sale, or for EEA residents, if service is required outside of the EEA, the owner will bear responsibility for any additional charges due to local practices and conditions, such as, but not limited to, freight, insurance, taxes, license fees, import duties, and any and all other financial charges, including those levied by governments, states, territories and their respective agencies.

BRP reserves the right to improve or modify products from time to time without assuming any obligation to modify products previously manufactured.

TRANSFER

If the ownership of a product is transferred during the warranty coverage period, this limited warranty, subject to its terms and conditions, shall also be transferred and be valid for the remaining coverage period provided BRP or an authorized LYNX Distributor / Dealer receives a proof that the former owner agreed to the transfer of ownership, in addition to the coordinates of the new owner.

CONSUMER ASSISTANCE

In the event of a controversy or a dispute in connection with this limited warranty, BRP suggests that you try to resolve the issue at the LYNX

Distributor / Dealer level. We recommend discussing the issue with the authorized LYNX Distributor / Dealer's service manager or owner.

If the matter still remains unresolved, contact BRP by filling out the customer contact form at www.brp.com or contact BRP by mail at one of the addresses listed under the *CONTACT US* section of this guide.

ADDITIONAL TERMS AND CONDITIONS FOR FRANCE ONLY

The following terms and conditions are applicable to products sold in France only:

The seller shall deliver goods that are complying with the contract and shall be responsible for defects existing upon delivery. The seller shall also be responsible for defects resulting from packaging, assembling instructions or the installation when it is its responsibility per the contract or if accomplished under its responsibility. To be compliant with the contract, the good shall:

1. Be fit for normal use for goods similar thereto and, if applicable:
 - Correspond to the description provided by the seller and have the qualities presented to the buyer through sample or model;
 - Have the qualities that a buyer may legitimately expect considering the public declarations of the seller, the manufacturer of its representative, including in advertising or labeling; or
2. Have the characteristics mutually agreed upon as between the parties or be fit for the specific use intended by the buyer and brought to the attention of the seller and which accepted.

The action for failure to comply is prescribed after two years after delivery of the goods. The seller is responsible for the warranty for hidden defects of the good sold if such hidden defects are rendering the good unfit for the intended use, or if they diminish its use in such a way that the buyer would not have acquired the good or would have given a lesser price, had he known. The action for such hidden defects shall be taken by the buyer within 2 years of the discovery of the defect.

CUSTOMER INFORMATION

DATA PRIVACY INFORMATION

Bombardier Recreational Products inc., its affiliates and subsidiaries (“BRP”) is committed to protecting your privacy and support a general policy of openness about how we collect, use and disclose your personal information in the course of managing our relationship with you. **More details can be found by visiting BRP’s Privacy Policy at: <https://brp.com/en/privacy-policy.html> or by scanning the QR Code below.**

Please be assured that we have appropriate security measures in place to ensure that your personal information is protected against loss and unauthorized access.

Your personal information that may be collected by BRP, directly from you or from authorized dealers or authorized third parties, includes:

- **Contact, Demographic & Registration Information** (e.g., name, full address, phone number, email, gender, ownership history, language of communication)
- **Vehicle Information** (e.g., serial number, purchase and delivery date, unit usage, vehicle location and movements)
- **Third Party Information** (e.g., information received from BRP partners, joint-marketing activities information, social media)
- **Technological Information** (e.g., IP address, type of device, operating system, browser type, webpages you view, cookies and similar technologies when you use BRP or dealers’ websites or mobile application)
- **Interaction with BRP Information** (e.g., information collected when you call BRP’s in-house sales representatives, buy items on a BRP web Site, sign up for BRP emails, participate in BRP-sponsored contests and sweepstakes or attend BRP-sponsored events)
- **Transactional Information** (e.g., information necessary to handle returns, payment information when you purchase our products or services through our websites or mobile applications and other issues related to your purchase of BRP products)

This information may be used and processed for the following purposes:

- Safety & Security
- Customer Support for Sales & After Sales (e.g., complete or follow up with you about your purchase or maintenance)
- Registration & Warranty
- Communication (e.g., sending you a BRP satisfaction survey)
- Online Behavioural Advertising, Profiling and Location-Based Services (e.g., offer customized experience)
- Compliance & Dispute Resolution
- Marketing & Advertising
- Assistance (e.g., help with any delivery issues, handle returns, and other issues related to your purchase of BRP products).

We also may use personal information to generate aggregated or statistical data that no longer identifies you personally.

Your personal information may be disclosed to the following: BRP, BRP's authorized dealerships, distributors, service providers, advertising & market research partners and other authorized third parties.

We may receive information about you from diverse sources, including third parties, such as BRP's authorized dealerships and partners, with whom we offer services or engage in joint-marketing activities. We may also receive information about you from social media platforms such as Facebook and Twitter, when you interact with us on those platforms.

Depending on the circumstances, your personal information may be communicated outside the region where you reside. Your personal information is retained only for as long as necessary for the purpose for which we obtained it and according to our retention policies.

To exercise your data privacy rights (e.g. right of access, right of rectification), to withdraw your consent in order to be removed from the address list for marketing purposes or for the satisfaction survey or for general data privacy questions, please contact BRP's Data Protection Officer at or by mail at **privacyofficer@brp.com** or by mail at: BRP Legal Service, 726 St-Joseph, Valcourt, Quebec, Canada, J0E 2L0.

When BRP processes your personal information, they do so in compliance with its Privacy Policy available at: <https://www.brp.com/en/privacy-policy.html> or by using the following QR Code.



CONTACT US

www.brp.com

Asia Pacific

Australia

Level 26
477 Pitt Street
Sydney, NSW 2020

China

上海市徐汇区衡山路10号6号楼301
Rm 301, Building 6,
No.10 Heng Shan Rd,
Shanghai, China

Japan

21F Shinagawa East One Tower
2-16-1 Konan, Minato-ku-ku,
Tokyo 108-0075

New Zealand

Suite 1.6, 2-8 Osborne Street,
Newmarket, Auckland 2013

Europe, Middle East and Africa

Belgium

Oktrooiplein 1
9000 Gent

Czech Republic

Stefanikova 43a
Prague 5
150 00

Germany

Itterpark 11
40724 Hilden

Finland

Isoaavantie 7
PL 8040
96101 Rovaniemi

France

Arteparc Bâtiment B
Route de la côte d'Azur,
13 590 Meyreuil

Norway

Ingvald Ystgaardsvei 15
N-7484 Trondheim
Salg, marketing, ettermarked

Sweden

Spinnvägen 15
903 61 Umeå
Sweden 90821

Switzerland

Avenue d'Ouchy 4-6
1006 Lausanne

Latin America

Brazil

Av. James Clerck Maxwell, 230
Campinas, Sao Paulo
CEP 13069-380

Mexico

Av. Ferrocarril 202
Parque Industrial Querétaro
Santo Rosa Jauregui, Querétaro
C.P. 76220

North America

Canada

3200A, rue King Ouest,
Suite 300
Sherbrooke (Québec) J1L 1C9

United States of America

10101 Science Drive
Sturtevant, Wisconsin
53177

CHANGE OF ADDRESS/OWNERSHIP

If your address has changed or if you are the new owner of the snowmobile, be sure to notify BRP by either:

- Notifying an authorized BRP snowmobile dealer or distributor.
- **North America Only:** calling at 1 888 272-9222.
- Mailing one of the change of address cards on the following pages at one of the BRP addresses indicated in the *Contact Us* section of this guide.

In case of change of ownership, please join a proof that the former owner agreed to the transfer.

Notifying BRP, even after the expiration of the limited warranty, is very important as it enables BRP to reach the snowmobile owner if necessary, like when safety recalls are initiated. It is the owner's responsibility to notify BRP.

STOLEN UNITS: If your personal snowmobile is stolen, you should notify BRP or an authorized BRP snowmobile dealer. We will ask you to provide your name, address, phone number, the vehicle identification number and the date it was stolen.

This page is
intentionally blank



CHANGE OF ADDRESS CHANGE OF OWNERSHIP

VEHICLE IDENTIFICATION NUMBER

Model Number

Vehicle Identification Number (V.I.N.)

OLD ADDRESS
OR PREVIOUS OWNER:

NAME

NO. STREET APT

CITY STATE/PROVINCE ZIP/POSTAL CODE

COUNTRY TELEPHONE

NEW ADDRESS
OR NEW OWNER:

NAME

NO. STREET APT

CITY STATE/PROVINCE ZIP/POSTAL CODE

COUNTRY TELEPHONE

E-MAIL ADDRESS

This page is
intentionally blank



CHANGE OF ADDRESS CHANGE OF OWNERSHIP

VEHICLE IDENTIFICATION NUMBER

Model Number Vehicle Identification Number (V.I.N.)

OLD ADDRESS
OR PREVIOUS OWNER:

NAME

NO. STREET APT

CITY STATE/PROVINCE ZIP/POSTAL CODE

COUNTRY TELEPHONE

NEW ADDRESS
OR NEW OWNER:

NAME

NO. STREET APT

CITY STATE/PROVINCE ZIP/POSTAL CODE

COUNTRY TELEPHONE

E-MAIL ADDRESS

This page is
intentionally blank



CHANGE OF ADDRESS

CHANGE OF OWNERSHIP

VEHICLE IDENTIFICATION NUMBER

Model Number

Vehicle Identification Number (V.I.N.)

OLD ADDRESS
OR PREVIOUS OWNER:

NAME

NO.

STREET

APT

CITY

STATE/PROVINCE

ZIP/POSTAL CODE

COUNTRY

TELEPHONE

NEW ADDRESS
OR NEW OWNER:

NAME

NO.

STREET

APT

CITY

STATE/PROVINCE

ZIP/POSTAL CODE

COUNTRY

TELEPHONE

E-MAIL ADDRESS

This page is
intentionally blank

Model No. _____

VEHICLE

IDENTIFICATION NUMBER (V.I.N.) _____

ENGINE

IDENTIFICATION NUMBER (E.I.N.) _____

Owner: _____

NAME

No. _____ STREET _____ APT _____

CITY _____ STATE/PROVINCE _____ ZIP/POSTAL CODE _____

Purchase Date _____
YEAR MONTH DAYWarranty Expiry Date _____
YEAR MONTH DAY

To be completed by the dealer at the time of the sale.

DEALER IMPRINT AREA

 **WARNING**

Disregarding any of the safety precautions and instructions contained in the operator's guide, safety video and on product safety labels could cause injury including the possibility of death.



®TM AND THE BRP LOGO ARE TRADEMARKS OF BOMBARDIER RECREATIONAL PRODUCTS INC. OR ITS AFFILIATES.
©2023 BOMBARDIER RECREATIONAL PRODUCTS INC. ALL RIGHTS RESERVED.

www.brp.com

619901020