

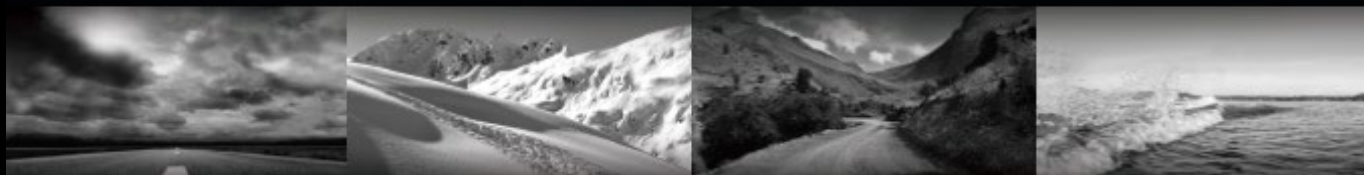

ski-doo *LYNX* *SEA-DOO* *ROTAX* *can-am*



EXOME HELMET

USER GUIDE

USER GUIDE

EXOME

ENGLISH



EXOME Helmet

CONGRATULATIONS!

You now have in your possession our newly designed Exome helmet. This modular style helmet has been engineered to give you the absolute winter trail experience. The incredible nature of the modular helmet allows you to easily spend a whole day without taking the helmet off at all!

If equipped with the new mask system, it gives you comfort and a fog free experience no matter the condition or day ahead! With our new mask system, you can ride, feeling confident that all humidity will be drawn out of the helmet through our patented mask system technology.

This helmet has also gone through rigorous testing and has passed even the most advanced DOT and/or ECE certification, so you can worry less about your helmet and truly focus on the adventure ahead.

You can feel secure in the knowledge that you now own a quality helmet that is designed to provide you safety and high standards of performance – in particular on long journeys – and that will give you a great deal of pleasure at the same time.

Please take the time to read through this manual carefully so that your helmet protects you properly when riding your vehicle. To ensure that you do not overlook any aspect of the manual that is relevant to your safety, we recommend that you read it in the order in which it appears.

WARNING

This helmet complies with U.S. Federal Motor Vehicle Safety Standard 218 (DOT FMVSS 218) and/or the United Nations Economic Commission for Europe Regulation 22 (ECE R22.06). This helmet was not designed to be used by a child under 13.

We wish you a safe ride.



CONTENTS

A. GENERAL	4
1. SAFETY INFORMATION	4
2. MINIMAL REQUIREMENT	5
B. THE HELMET	5
1. ANATOMY OF THE HELMET	5
2. HELMET SIZING	5
3. BREATH VENTILATION SYSTEM COMPONENTS	5
4. CHIN CURTAIN	6
5. MICROMETRIC CHIN STRAP	7
6. BREATH VENTILATION SYSTEM	8
7. FACE SHIELD	9
8. SUN VISOR	11
9. FACE SHIELD MECHANISM	12
10. INNER LINER	13
11. VENTILATION SYSTEM	15
C. FIT & USAGE	15
1. HOW TO PUT THE HELMET ON	15
2. PROPER FIT	16
3. PUT THE HELMET OFF	17
4. OPERATING INSTRUCTIONS	17
D. BEFORE EVERY RIDE	18
1. CHECKING THE HELMET	18
2. CHECKING THE CHINSTRAP	19
3. CHECKING THE FACE SHIELD AND SUN VISOR	19
E. OTHER IMPORTANT INFORMATION	20
1. MODIFICATIONS / ACCESSORIES	20
2. FROSTBITE	20
F. CARE AND MAINTENANCE	21
1. SHELL CLEANING	21
2. INTERIOR CLEANING	21
3. OUTER SURFACE OF THE FACE SHIELD	21
4. HEATING LENS	21
5. SUN VISOR	22
6. HELMET INSPECTION	22
7. HELMET STORAGE	22

G. TROUBLESHOOTING GUIDE	23
H. ACCESSORIES AND SPARE PARTS	24
1. ACCESSORIES	24
2. REPLACEMENT PARTS	24
I. BRP SERVICE	24
1. REPAIR SERVICE	24
2. WARRANTY	24
J. HOW TO CONTACT US	25

A. GENERAL

1. SAFETY INFORMATION

This helmet is backed by the BRP warranty and a network of authorized dealers and distributors ready to provide the parts, service, or accessories that you may require. Genuine BRP parts should be used for replacement to maintain the warranty, consult an authorized BRP dealer.

Use this User Guide to acquaint yourself with your new helmet and its various functions. Make sure you read and understand the contents of this guide and keep it for future reference. The information and components descriptions contained in this guide are accurate at time of publication. The illustrations in this document may not show the typical construction of the different assemblies or may not reproduce the full detail or exact shape of the parts shown, however, they represent parts which have the same or a similar function.

This guide uses the following safety alert symbol  in conjunction with signal words to indicate a potential personal injury hazard.

 WARNING
Indicates a hazardous situation which, if not avoided, could result in death or serious injury.

NOTICE
Address practices not related to personal injury.

Simply reading this guide will not eliminate hazards. The user must understand and follow the instructions. Because of its ongoing commitment to product quality and innovation, BRP reserves the right at any time to discontinue or change specifications, designs, features, or equipment without incurring obligation. If anyone seeks to translate any portion of this guide into any language, this person must ensure that the translation is accurate.

WARNING

Riding a motorized vehicle can be extremely dangerous. This helmet provides limited protection to the head. It complies with U.S. Federal Motor Vehicle Safety Standard 218 (DOT FMVSS 218) and/or the United Nations Economic Commission for Europe Regulation 22 (ECE R22.06).

However, it will not protect the wearer against all possible impacts. Some impacts may exceed this helmet's capability to provide protection and result in serious head, brain, spinal, or other injury including paralysis or death. For maximum protection, the helmet must fit firmly on the head with the chin strap securely fastened.

If your helmet is equipped with a main visor, it must be fully closed. If your helmet is equipped with other component, such as wind deflector, breath deflector, breathing mask, mandible, etc., make sure to install them in proper position to direct exhaled breath away from the main visor. Always wear appropriate protection against frostbite, which may include a balaclava, neck tube, facemask, or combination of these items.

Inspect the helmet before each use following the inspection procedure in the instructions. Replace any part showing wear or damage. Do not alter the helmet or attach any items not recommended by the manufacturer. The helmet is designed to absorb shock by partial destruction of the shell and it should not be visible. Destroy and replace helmet if subjected liner, which may not be visible. Destroy and replace helmet if subjected to a severe blow even if it appears undamaged.

The helmet shell, liner and other components may be damaged and rendered ineffective by petroleum products, cleaning agents, paint, adhesives, etc., without the damage being visible. Use only warm mild soapy water to clean the helmet.

Follow all warnings and instructions provided with this helmet. For replacement instructions, contact BRP. Failure to follow all warnings and instructions can result in serious personal injury or death.

A. GENERAL

2. MINIMAL REQUIREMENT

If your new EXOME helmet is equipped with electrified feature such as a heated visor who require to be operated on a **12VDC** power source (normally in between 11.5VDC to 16.5VDC).

Note: Your vehicle power capacity (i.e.: generator, battery, etc.) combined to the number of accessories installed (i.e.: heated seat, auxiliary light, etc.) may affect the performance of the helmet. Please consult an authorized BRP dealer or distributor at any time for help and support.

B. THE HELMET

1. ANATOMY OF THE HELMET

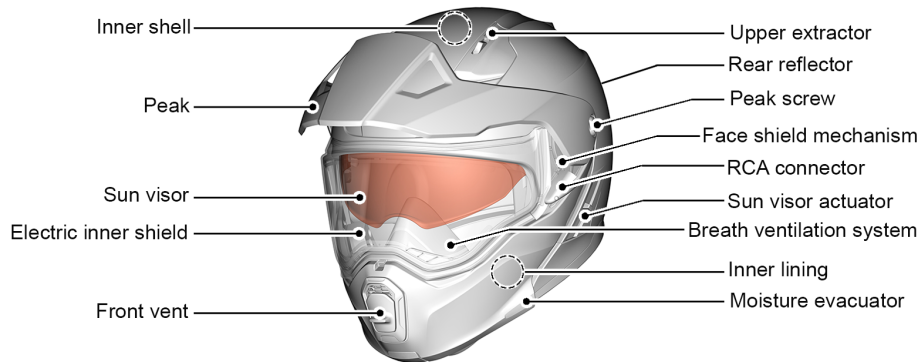

2. HELMET SIZING

Helmet size	XS	S	M	L	XL	2XL	3XL	
Shell size	S			L				
Head size	mm	53 - 54	55 - 56	57 - 58	59 - 60	61 - 62	63 - 64	65 - 66
	Inches	20 7/8 - 21 1/4	21 5/8 - 22	22 3/8 - 22 3/4	23 1/8 - 23 5/8	24 - 24 3/8	24 3/4 - 25 1/8	25 1/2 - 25 7/8

3. BREATH VENTILATION SYSTEM COMPONENTS

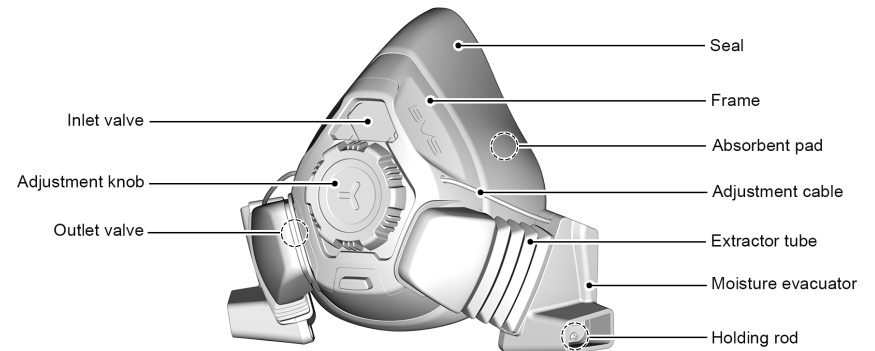

B. THE HELMET

4. CHIN CURTAIN

The chin curtain reduces air intrusion and unpleasant effect of the wind created when you ride by flowing into the helmet. This feature allows to also reduce the riding noises (such as wind, motor, track...).

The fit at the bottom of the helmet is extremely important to make the helmet as quiet as possible. Even with the chin curtain, we recommend you wear a balaclava.

REMOVING THE CHIN CURTAIN

1. The chin curtain is attached on the chin portion by 4 “arrow snaps”.

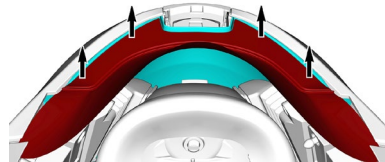

To remove the chin curtain, take one side of the chin curtain pull gently upward to disengage the plastic arrow snap.

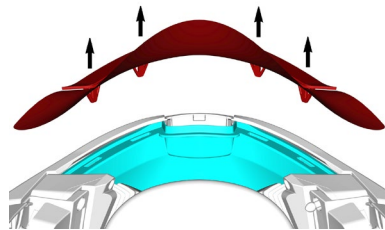

INSTALLING THE CHIN CURTAIN

1. Insert the 4 “arrow snaps” of the chin curtain into their specific housing on the chin portion.

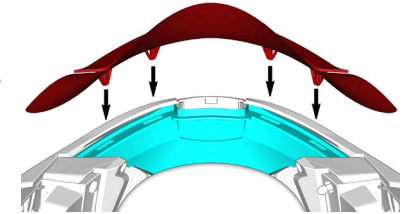

2. Press one by one on the plastic arrow snap to be sure each one is engage in the chin plastic strip housing as shown.

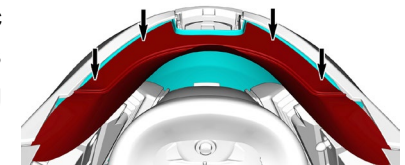

⚠ WARNING

Do not carry or hold the helmet by the chin curtain. The chin curtain may come off, causing the helmet to drop.

B. THE HELMET

5. MICROMETRIC CHIN STRAP

The retention system of the EXOME helmet comes with a ratchet fastener. This locking system is easy to use and enables you to adjust the chinstrap perfectly to your head every time you put the helmet on.

ADJUSTING THE CHIN STRAP

The length of the chinstrap is adjusted by increasing or reducing the length of strap pulled through the metal buckles. Adjust the length of the chinstrap so that it fits firmly but comfortably under your chin and fix the end of the strap using the retaining loop with comfort pad.

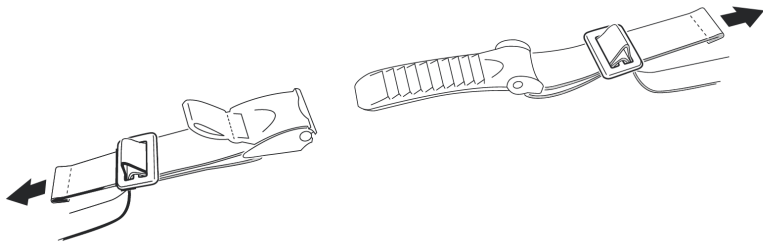

⚠ WARNING

When adjusting the strap, make sure that the helmet cannot be pulled off in a forward direction with the chinstrap closed.

⚠ WARNING

Check the adjustment of the chinstrap length at regular intervals.

OPENING AND CLOSING

To close the chinstrap fastener, slide the ratchet tongue step by step into the locking buckle. If you find that the chinstrap fits too loosely around your chin, slide the ratchet tongue one step further into the locking buckle.

When adjusting the chinstrap, make sure that it rests firmly but not uncomfortably around your chin. To open the chinstrap, pull the red ribbon on the ratchet fastener upwards to release the locking buckle. Then pull the ratchet tongue out of the locking buckle.

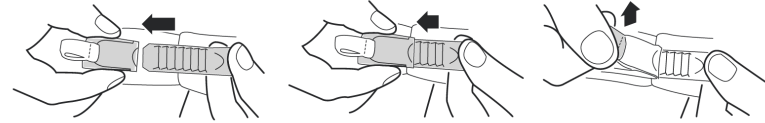

⚠ WARNING

Never ride without making sure that the chinstrap is correctly fastened and adjusted and properly positioned. If the chinstrap is not correctly adjusted or fastened, the helmet could be displaced in the event of an accident.

⚠ WARNING

Closing the comfort pad of the chinstrap alone will not provide adequate protection. The chinstrap must always be fully fastened.

⚠ WARNING

Never open the chinstrap while riding.

B. THE HELMET

6. BREATH VENTILATION SYSTEM (WINTER MODEL)

The EXOME helmet's breath ventilation system contributes greatly to the overall performance of the helmet and the comfort of the wearer.

This system is designed to be easy to use and to allow the operator to focus on the trail rather than on the fog.

INSTALLATION AND ADJUSTMENT

For optimal performance of the EXOME helmet, it is essential to ensure that the breath ventilation system is properly installed and adjusted.

1. Make sure the adjustment cable is free to move from left to right. With the helmet on your head and the jaw in the open position, install the retaining pin in the opening provided on the side of the helmet.

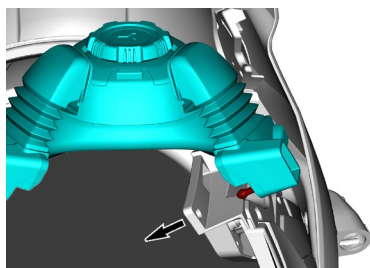

2. Rotate the breath ventilation system on the other side until it is securely in position.

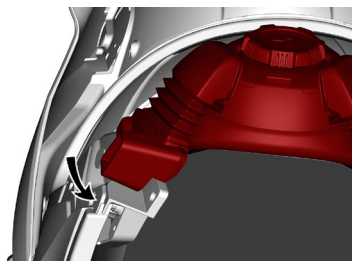

3. Ensure that the breath ventilation system is securely attached, then adjust the pressure of the breath ventilation system on the face by turning the adjustment knob.

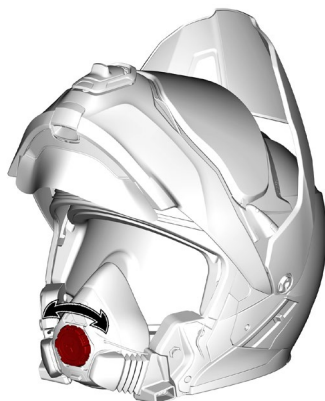

4. For optimum performance, it is important that the seal between the mask and the face is completely tight. To verify the seal, block the moisture vents and then attempt to exhale. If air is escaping, the mask is either not positioned correctly or the pressure on the face is not enough. Readjust the mask, then retest.

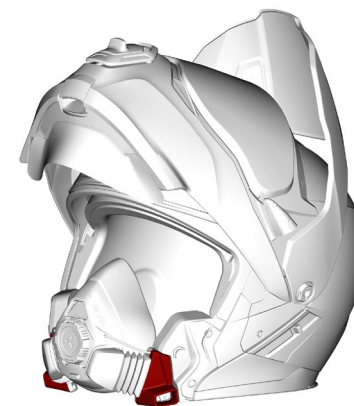

5. Validate that the absorption pad is in the right orientation.



6. Insert the absorption pad by starting with the upper part into the breath ventilation system as illustrated.



7. Change the absorption pad when it is saturated with water.



B. THE HELMET

7. FACE SHIELD

Changing the face shield is easy to do without tools. To replace the visor, it is helpful to place the helmet on a flat surface on soft cloth or on your lap while seated.

REMOVING THE FACE SHIELD

1. Make a quarter turn to the peak screw.

- Clockwise to unlock right side
- Counterclockwise to unlock left side

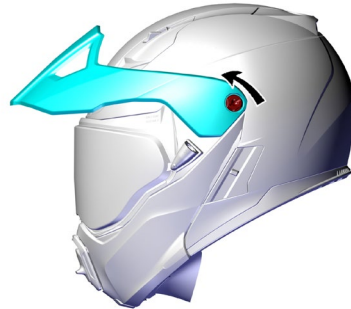

2. Pull perpendicularly on the side of the peak as shown.



3. Repeat steps 1 - 2 for the other side.

4. Move the face shield into the uppermost locked position.



5. On one side, pull the lever of the face shield mechanism downward to release the lower tab of the face shield.

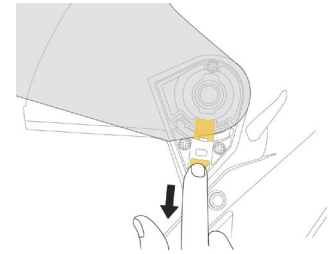

6. Move the lower portion of the face shield upwards until the lower tab is released from the face shield mechanism.

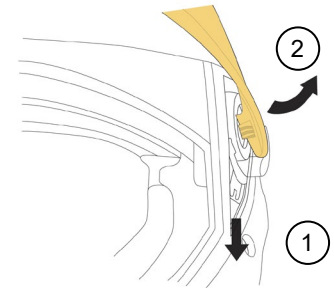

7. Then, pull the face shield downward to release the upper tab from the face shield mechanism.

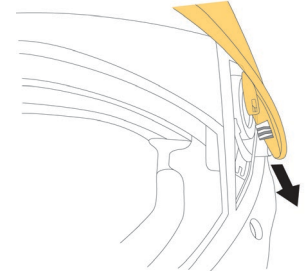

8. Repeat steps 5 – 7 for the other side.

B. THE HELMET

INSTALLING THE FACE SHIELD

1. Insert the upper tab of the face shield into the specific location on the face shield mechanism.

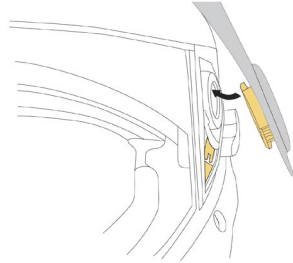

2. Once the tab is in position, pull the lever of the face shield mechanism downward and slightly push the lower portion of the face shield to put back in position the lower tab of the face shield.

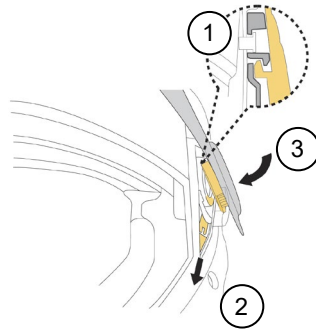

3. Then, release the lever. Make sure the spring put it back to the up position and check if the visor is correctly in place.

4. Repeat steps 1 - 3 for the other side.

For the other side, note that the face shield will be slightly tilted. Make sure the lower tab of the face shield and the recess are perfectly aligned.

5. Once both sides are in position, press the face shield pivots gently towards the helmet with a simultaneous closing movement.

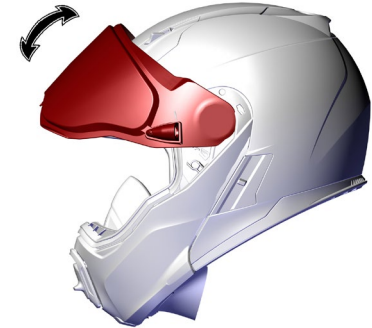

6. Make sure that the face shield mechanism is functioning properly by closing and opening the face shield to its maximum extent.

B. THE HELMET

8. SUN VISOR

OPERATION

The sun visor is operated by the lever positioned on the left side of the helmet, which makes it easy to use even when wearing thick gloves.

Moving the lever upward lowers the sun visor, moving it downward retracts the sun visor inside the inner helmet shell and locks it in position.



REMOVING THE SUN VISOR

1. Turn the helmet jaw to the open position.



2. Remove breath ventilation system.

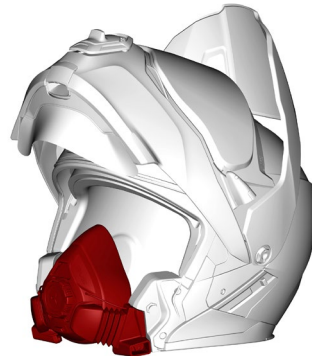

3. Pivot the sun visor in the lower position.

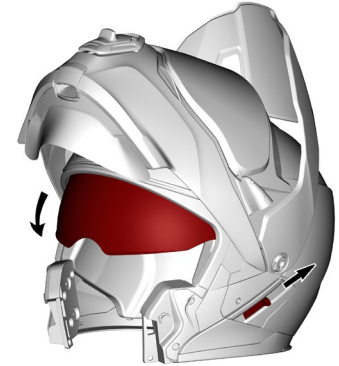

4. Pull the sun visor downward until you see the upper edge.

5. Hold your helmet in position and pull the sun visor on the right side, toward the outside of the helmet.

6. Repeat steps 4-5 for the other side.

The sun visor lever should remain in the same position while you install the visor.

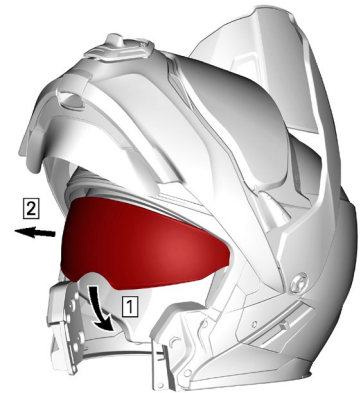

B. THE HELMET

INSTALLING THE SUN VISOR

1. Make sure the sun visor mechanism is in low position. (Sun visor lever up)

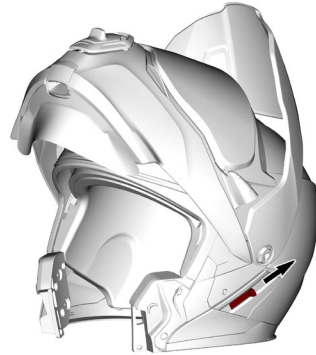

2. Insert the sun visor between helmet inner and outer shell and fit it on to the locating pegs on both sides.

Then, press firmly towards the inside of the helmet until the fork's inner insert is completely inserted.

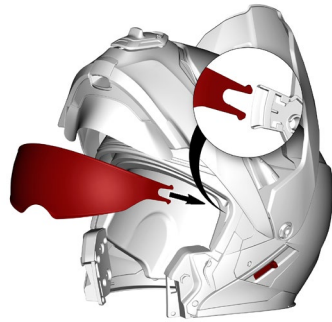

3. Check that the sun visor mechanism is functioning correctly.



9. FACE SHIELD MECHANISM

REMOVING / REPLACING THE FACE SHIELD MECHANISM

1. Remove the face shield as described in the "7. FACE SHIELD" section of this manual.

2. Use a Phillips #1 screwdriver to remove the two screws.

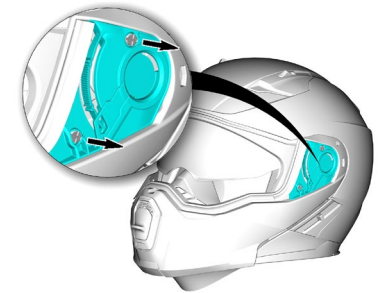

3. Grab the sun visor mechanism and lift it gently.

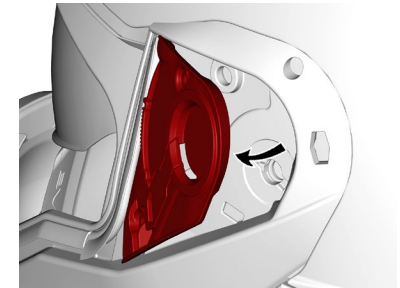

4. Position the sun visor mechanism and put back the two screws. Tighten them to 0.4 Nm.

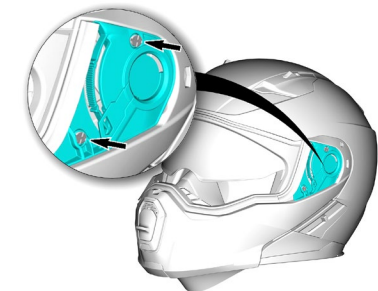

5. Repeat steps 2 – 4 for the other side.

6. Put back the face shield as described in the "7. FACE SHIELD" section of this manual.

B. THE HELMET

10. INNER LINER

The replaceable inner lining of the EXOME helmet is washable and ensures both an excellent fit and improved ventilation of the helmet.

The dual-density cheek pads have a specific 3D shape to ensure that the helmet fits comfortably around the cheeks, and the headliner provides an optimal fit all around the head.

All interior fittings are made entirely of skin-friendly material. The material used for the cheek pads and head liner has been treated with an antimicrobial treatment.

When removing the lining, the cheek pads must first be detached before taking out the headliner pad. When fitting the lining, remember to insert the headband pad before the cheek pads.

PAD SIZES

Helmet size	XS	S	M	L	XL	2XL	3XL	
Cheek pad thickness	35 mm	30 mm	25 mm	35 mm	35 mm	30 mm	20 mm	
Head liner thickness	Top	16 mm	16 mm	16 mm	16 mm	12 mm	12 mm	12 mm
	Crown	18 mm	16 mm	16 mm	18 mm	8 mm	6 mm	6 mm

REMOVING THE CHEEK PADS

1. With the jaw in the open position, detach the Velcro™ and the 2 snaps by pulling the cheek pad towards the inside of the helmet.

2. Slide the chinstrap into the cheek pad notch.

3. Repeat these steps for the other side.



INSTALLING THE CHEEK PADS

1. Before installing the cheek pads, identify the right and the left sides.

2. Fasten the 2 snaps and attach the Velcro™ upper part in position. Make sure the strap is in position inside the cheek pad notch.

3. Repeat these steps for the other side.



B. THE HELMET

REMOVING THE HEAD LINER

1. First, remove the rear portion of the head liner. The head liner is attached to the inner shell with 2 snaps (on each side of the neck) and a frontal portion, with 3 plastic strips.



2. Then you can remove the frontal portion by pulling the 3 plastic strips out carefully. For the frontal portion, start to pull from one side of the plastic strip.



INSTALLING THE HEAD LINER

1. Insert the frontal plastic strip under the notches of the other plastic strip attached to the inner shell.



2. Next, position the head liner inside the helmet.

3. Then, fasten the 2 snaps on the neck portion.



WARNING

Never ride when parts of the inner lining have been removed.

To avoid damage to the inner lining and inner shell, do not hang the helmet over the mirrors or handlebar grips.

B. THE HELMET

11. VENTILATION SYSTEM

The EXOME helmet has a two-way adjustable ventilation system. As needed, you can modulate the air flow as per three distinct configurations:

1. The front vent is adjustable in 3 positions. When the sliding button is in the highest position, the vent is closed. When the sliding button is lowered, it switches to partially open and then fully open.

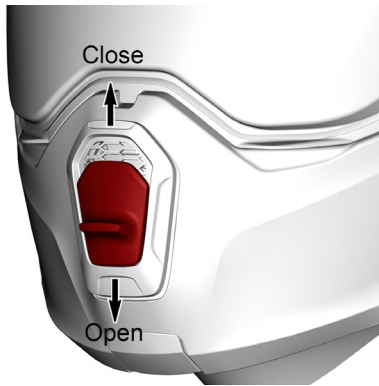

2. The upper extractors are adjustable in 2 positions. They are either fully closed or fully open. For the winter model, when the sliding button is in the front position it corresponds to the fully open mode and when the sliding button is in the rear position it corresponds to the fully closed mode. For the summer model, it is the opposite.

Winter model

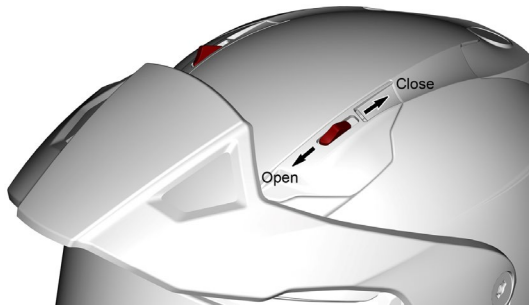

Summer model

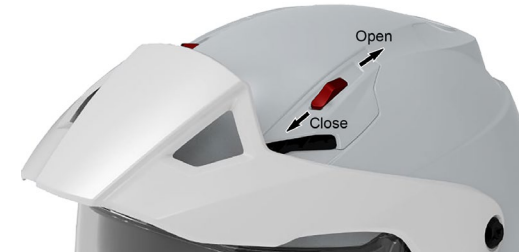

In all three cases, it allows you to increase or reduce the air flow to reach the desired level of comfort.

Note that the snowmobile speed, the windshield, or the head rotation can affect the air flow inside the helmet.

C. FIT & USAGE

1. HOW TO PUT THE HELMET ON

1. Make sure the sun visor is retracted into the helmet shell.
2. Move the neck protector outward to clear the opening.
3. Turn the helmet jaw to the open position.
4. Open the breath ventilation system.
5. Open the chinstrap and chinstrap comfort pad.
6. Pull apart the lower ends of the chinstrap.
7. It will now be easy to put the helmet on.
8. Close and fasten the chinstrap.
9. Make sure the chinstrap passes under the chin and fits snugly.
10. Check that the helmet jaw is securely locked by pushing it up from below.

C. FIT & USAGE

2. PROPER FIT

WARNING

Wearing the wrong helmet size can increase the risk of serious injury or death in an accident. A helmet that is too large for your head may be dislodged or knocked off in an accident.

To select the right helmet size for your head, follow the steps:

1. TRY ON THE HELMET

Grasp both chin straps to pull the helmet completely onto your head, ensuring that the top of your head is in contact with the top of the helmet interior. Try the helmet with all the protection you plan to use (balaclava, neck tube, etc.)

2. CHECK FOR A PROPER FIT

To make sure that your helmet is the right size, check that:

- The helmet inner lining fits snugly around your head.
- The top pad presses firmly on your head.
- The cheek pads contact your cheeks.
- There is no space around your brow under the inner lining. Test this by trying to insert your fingers. If the helmet does not fit snugly, try on a smaller size.

This step might take several trials before finding the perfect adjustment.

3. CHECK YOUR FIELD OF VISION

Some helmets may obstruct or block your vision when looking left, right, up, or down.

WARNING

Always make sure you can see well enough to safely operate your vehicle.

4. TEST THE HELMET FIT

Place your hands on each side of the helmet. While holding your head as motionless as possible, try rotating your helmet from left to right then up and down. You should feel the helmet move the skin on your head and face as you try to move the helmet.

If it is not the case or if you can feel the helmet padding sliding on your head, it is too big. If the helmet is constricting or painful, it is too small.



5. FASTEN THE CHIN STRAP

Tight it under your jaw until it remains no slack in the strap, and the strap must be tight up against your jaw.

6. TEST THE CHIN STRAP FIT

- Put your hands on the back of the helmet (B) and try to push the helmet off by rotating it forward.
- Put your hands on the front of the helmet above your forehead (or on the chin guard) and try to push.
- If helmet comes off, try another size or model.

Repeat steps 1 through 6 until you find a helmet that fits your head snugly and securely.

C. FIT & USAGE

3. PUT THE HELMET OFF

1. Make sure the sun visor is retracted.
2. Move the neck protector outward to clear the opening.
3. Turn the helmet jaw to the open position.
4. Open the breath ventilation system.
5. Open the chinstrap and chinstrap comfort pad.
6. Pull apart the lower ends of the chinstrap.
7. The helmet can now be removed easily.

To avoid scratching any objects you might place the helmet on, we recommend closing the chin-strap after you have taken the helmet off.

4. OPERATING INSTRUCTIONS

CONNECTING THE POWER CABLES

We highly recommend that you get your helmet cables connected by an authorized BRP dealer so that he can refer to the vehicle's shop manual to determine the best connection point.

1. Vehicle Connection

- Option 1a: Via the vehicle's power outlet intended for this purpose (sold separately).

For more details, see your authorized BRP dealer or distributor.

- Option 1b: Via the battery power outlet intended for this purpose (sold separately).

For more details, see your authorized BRP dealer or distributor.

WARNING

It is important not to connect the helmet to another electrical accessory (like heated grips) to avoid overloading existing circuits. This could lead to a fire.

2. Power cable (vehicle side)

- Connect the vehicle power cable to the main power outlet (1a or 1b) and leave it in position for further use.

3. RCA power cable

- Then, place your riding coat on a clean surface and route the RCA power cable as shown below:

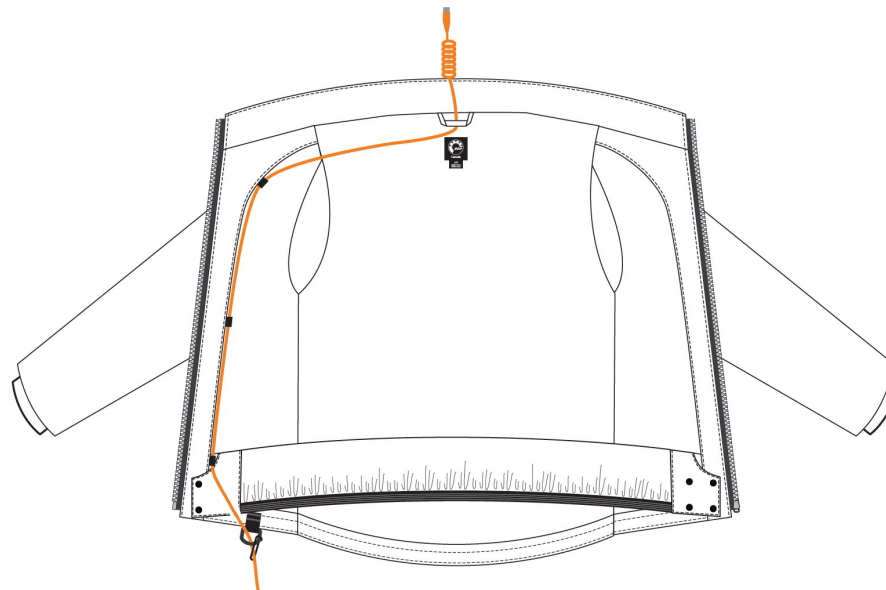

C. FIT & USAGE

4. Final connection

- Once the RCA power cable is in place, put on your coat and let the power cable pass under your left or right arm, depending which side is your key ring on your jacket;
- Put on your helmet as described in the “1. HOW TO PUT HELMET ON” section of this manual;
- Grab the RCA power cable at the back of your neck and bring it closer to the connection housing at the left side of the helmet.
- Next, grab the RCA cable end and connect it to the vehicle power cable.

WARNING

Ensure that the cables stay away from any moving parts. Do not let the power cables become entangled in the vehicle and do not drive over them. Do not use any extension. If the cables are damaged, stop using them. Discard and replace them with new OEM BRP cables.

WARNING

The magnets contained in this helmet could interfere with the operation of electronic devices such as pacemakers. Please consult your doctor before wearing this product.

Also, note that the credit cards' magnetic stripe could be affected.

D. BEFORE EVERY RIDE

1. CHECKING THE HELMET

Regularly inspect your helmet for damage. Small superficial scratches will not impair the protective function of your helmet.

WARNING

In the case of more serious damage (cracks, dents, flaking and cracking paint, etc.), the helmet should no longer be used.

D. BEFORE EVERY RIDE

2. CHECKING THE CHINSTRAP

1. Check that the chinstrap passes under your chin.
2. Slip your index finger under the chinstrap and pull.
If the chinstrap is loose under the chin, it is too long and needs to be tightened. If the chinstrap loosens when you pull it, it is not properly fastened. Undo the chinstrap completely and try fastening it again. Repeat the test.
3. If you are unable to fasten the chinstrap so that it fits firmly against the chin, check that your helmet is still the right size for you.

Repeat the test after each adjustment.

WARNING

Never ride with the chinstrap unfastened or incorrectly adjusted. The chinstrap should fit correctly and should not become loose when pulled. The fastener is not correctly closed if the chinstrap becomes loose when pulled.

3. CHECKING THE FACE SHIELD AND SUN VISOR

The protective film used during shipping should be removed before use.

Before every ride, check that the mechanisms of the face shield and sun visor are working properly and that the face shield and sun visor will provide sufficiently clear visibility. Any dirt should be removed before riding.

Check the face shield and sun visor for physical damage and cracks. A badly scratched face shield will considerably impair your vision and should be replaced before setting off on a journey.

WARNING

Never use tinted face shield or sun visor in conditions of poor visibility, when riding at night or in a tunnel.

WARNING

A scratched and/or dirty face shield will seriously impair visibility. For your own safety, replace it or clean it immediately.

WARNING

Make sure the face shield and sun visor are always in good condition. A damaged face shield is not suitable for riding and needs to be replaced.

WARNING

Stop riding if visibility is poor.

E. OTHER IMPORTANT INFORMATION

1. MODIFICATIONS / ACCESSORIES

WARNING

Original components (in particular on the outer shell, inner shell and restraint system) should not be altered or removed.

Remember that installing unapproved accessories or doing any helmet modification can reduce the protective effect, renders the certification, all warranty and insurance claims invalid.

Use only original parts, replacement parts and accessories that BRP has expressly approved for your helmet!

Modifying your helmet may reduce its ability to protect you and increase your risk of serious injury or death in an accident.

Modifications include the following:

- Drilling holes
- Cutting shell, strap or shock absorbing liner
- Pressing shock absorbing liner
- Modifying the retention system, including adding a chin cup
- Removing parts
- Painting
- Using adhesives
- Installing unapproved accessories

2. FROSTBITE

WARNING

What is frostbite?

Frostbite can be defined as the freezing of the skin and/or the bodily tissues under the skin. It is thermal injury that can result from prolonged exposure to moderate cold or brief exposure to extreme cold.

What causes frostbite to occur?

Different factors can contribute to the occurrence of frostbite such as:

- Length of time a person is exposed to the cold;
- Temperature outside;
- Force of the wind (wind-chill factor);
- Humidity in the air;
- Wetness of clothing;
- Previous frostbite or cold injury.

How to prevent frostbite

- Do not go outdoors for prolonged periods in severely cold weather.
- Always wear additional headwear such as a balaclava, neck tube, face mask, or a combination of those items.
- Change any wet clothes immediately.
- Watch for signs of frostbites frequently: Red or pale skin, prickling and numbness.
- Avoid caffeine, tobacco and alcohol when going out in the cold, as these leave the skin more prone to thermal injury;

Sources:

- National Institutes of Health's Website:

<https://medlineplus.gov/frostbite.html>

<https://medlineplus.gov/ency/patientinstructions/000866.htm>

F. CARE AND MAINTENANCE

WARNING

Never use petroleum-based chemicals, solvents, gasoline, cleaning agents or adhesives to clean the shell, liners or visors of your helmet. Your helmet shell, liner and visors may be seriously damaged by the use of such products and the full safety function of the helmet can then no longer be guaranteed.

1. SHELL CLEANING

To clean the helmet shell, you can use water, soap or one of the commonly available motorcycle shampoos, cleaners, polishes, plastic cleaners or cleaning fluids.

Using water and soap is usually sufficient. Make sure when using the other cleaning materials that these do not come into contact with the face shield, since they can cause damage to the visor and its coating.

2. INTERIOR CLEANING

The inner lining of the EXOME helmet can be removed completely. The head and cheek pads can be washed by hand using a mild soap solution (e.g. with highly diluted standard mild detergent) at a maximum temperature of 30 °C.

Hand washing is recommended, but machine washing is also permitted. Use the "delicate" cycle to prevent the agitator from damaging the sweat-wicking material covering the liner parts. Allow the lining to dry at room temperature and with good ventilation.

WARNING

Do not place lining parts in the dryer: Excess heat may damage the foam and coverings.

3. OUTER SURFACE OF THE FACE SHIELD

The helmet's shields are specially treated on both sides with an ANTI-FOG or ANTI-SCRATCH coating.

Always use warm soapy water to clean the shields

Always use a soft clean cloth to wipe the shields and avoid scratching the surface.

Never use petroleum based chemicals, solvent, gasoline, cleaning agent or adhesives to clean the shields

4. HEATING LENS

The inside surface of the face shield must only be cleaned with a soft cloth, which may be slightly dampened if required (we recommend a microfiber cloth).

WARNING

Do not use any cleaning agents.

F. CARE AND MAINTENANCE

5. SUN VISOR

5.1 CLEANING THE SUN VISOR

The sun visor should only be cleaned with a soft and, if necessary, slightly damp cloth (we recommend a microfiber cloth).

Only use tepid water (< 20 °C) for cleaning. Never on any account clean the face shield or sun visor with petrol, solvent, a window or glass cleaner or other cleaning agents containing alcohol.

The face shield should not be soaked in water even if it is very dirty on the outside, as this will severely reduce the surface hardness and thus the durability of the anti-fog/anti-scratch coating.

Never attach labels, adhesive tape or stickers to the face shield or sun visor.

Stubborn dirt on the outer surface of the face shield (e.g. dried-on insect remains) can be easily removed by covering the closed visor with a moist or wet cloth and allowing the dirt to soften for around 30 minutes to 1 hour.

6. HELMET INSPECTION

Check for helmet damages. If your helmet is damaged or cracked, stop using it immediately and replace it.

Check for worn or damaged parts. Plastic components may wear out over time. If you find worn or damaged parts, replace them or purchase a new helmet. See "Replacement parts" for information on parts replacement.

WARNING

To reduce the risk of serious injury or death, always inspect your helmet before each ride.

The helmet should be replaced after 3 to 5 years after the date of purchase, depending on use and care. Although the outer shell is in principle capable of a longer service life, the occurrence of material fatigue and wear to other components, as well as the overall action of the helmet and the unknown conditions in which the helmet has been used, make it advisable for your own safety to replace the helmet after this period of use.

Excessive heat (e.g. exhaust heat) can cause damage to the helmet esthetics, the inner shell of the helmet and the interior lining.

7. HELMET STORAGE

- Store helmet in a cool and dry place;
- Keep helmet away from pets and other animals;
- Keep helmet away from heat more than 50°C (122°F) and do not set on or near hot surfaces;
- Store helmet in a helmet bag.

WARNING

Improperly stored helmet can become damaged.

G. TROUBLESHOOTING GUIDE

PROBLEM	ACTION
NO HEATING AND/OR FOG APPEARING ON THE MAIN VISOR	<ol style="list-style-type: none"> 1. Check if the heating visor has been damaged. Replace it if necessary. 2. Check if the power cable is properly connected to your vehicle and to your helmet. 3. Remove the face shield and make sure that the visor internal lens is properly sealed to detect fogging in between the two lenses. Replace it if necessary. 4. At IDLE, load shedding might happen on some vehicles, including BRP snowmobiles equipped with a 420W magneto. Run the engine at higher RPM (Rotation Per Minutes) a few minutes and it should turn on the main visor heating. Note that the time required to recover from the load shedding may vary depending on the condition of the battery and/or the vehicle model. <p>If the problem is still not resolved, go to your authorized BRP dealer for detailed inspection.</p>
THE HEATING VISOR SEEMS HAZY	<ol style="list-style-type: none"> 1. In unusual circumstances, a haze may appear on the surface of the anti-fog coating. This can be easily removed and never reappear by following these steps: <ol style="list-style-type: none"> a. Moisten a soft cloth with warm soapy water. b. Gently clean and let air dry. c. Let air dry without trying to rub dry. d. Repeat if necessary. 2. If the problem is still not resolved, check if the fog seems to be between the two lenses. If this is the case, go to your authorized BRP dealer for detailed inspection.
SUN VISOR DYSFUNCTIONING	<ol style="list-style-type: none"> 1. Check if the sun visor is installed and positioned correctly on the helmet. 2. Check if there are any broken parts. Replace them by new ones if necessary. 3. If the problem is still not resolved, go to your authorized BRP dealer for detailed inspection.
ICE FORMATION ON FACE SHIELD LATCH	<p>Make sure your face shield is properly closed.</p> <ol style="list-style-type: none"> 1. You should hear/feel a “click”. 2. Make sure you use the absorbent pad to reduce water accumulation in this area.
DIFFICULTY TO BREATHE IN THE MASK?	<ol style="list-style-type: none"> 1. Verify that the valves of the mask are working properly. 2. Verify the absorption pad, if it is completely soaked, replace it or at least try to remove water from it.

H. ACCESSORIES AND SPARE PARTS

You will find a summary of all available accessories and spare parts on internet at www.brp.com

WARNING

For safety reasons, all accessories should be approved by BRP for that specific helmet.

WARNING

Use of replacement parts other than the ones offered by BRP may increase your risk of serious injury or death. Only use parts that are specifically designed to work with this helmet. BRP recommends that all replacement parts shall be installed by a BRP dealer.

WARNING

Never modify your helmet – It may reduce your helmet's ability to protect you and increase your risk of serious injury or death.

1. ACCESSORIES

Original BRP accessories are available at your authorized BRP dealer. To find BRP dealers in your area, use the dealer search on the BRP website: www.brp.com

2. REPLACEMENT PARTS

Original BRP parts are available at your authorized BRP dealer. To find BRP dealers in your area, use the dealer search on the BRP website: www.brp.com

Note: For more information on available replacement parts, please visit our website at the following address: <http://store.ski-doo.com/>

I. BRP SERVICE

1. REPAIR SERVICE

The EXOME helmet is a BRP quality product that has been designed and manufactured using the latest development and production methods. If a repair to your helmet is necessary, please consult your authorized BRP dealer or distributor.

Upon receipt of a claim, BRP may examine the item and/or delay completion of the claim until the analysis is completed.

Even where a clear description of the original fault has been provided, if BRP discover further defaults during the repair, BRP may rectify these without a specific order if this is necessary to restore the correct functioning of the helmet.

2. LIMITED WARRANTY

Buying your helmet at an authorized BRP dealer provides a limited warranty for purchased equipment on manufacturing defects.

The limited warranty period is 4 years from the purchasing date. Should you have a reason to complain, please contact your authorized BRP dealer.

BRP ask that you provide a precise description of the claim as well as a copy of your receipt.

J. HOW TO CONTACT US

North America

565 de la Montagne Street
Valcourt (Québec) J0E 2L0
Canada

Sturtevant, Wisconsin, U.S.A.
10101 Science Drive
Sturtevant, Wisconsin
53177
U.S.A.

Sa De Cv, Av. Ferrocarril 202
Parque Ind. Querétaro, Lote2-B
76220
Santa Rosa Jáuregui, Qro.
Mexico

Oceania

6 Lord Street
Lakes Business Park
Botany, NSW 2019
Australia

South America

Rua James Clerck Maxwell, 230
TechnoPark Campinas
SP 13069-380
Brazil

Asia

15/F Parale Mitsui Building,8
Higashida-Cho, Kawasaki-ku
Kawasaki 210-0005
Japan

Room Dubai, level 12, Platinum
Tower
233 Tai Cang Road
Xintiandi, Lu Wan District
Shanghai 200

For your nearest authorized BRP dealer or distributor or for more information on BRP products, please visit our web site:

www.brp.com

©™ and the BRP logo are trademarks of Bombardier Recreational Products inc. or its affiliates.

© 2022. Bombardier Recreational Products Inc.

BRP_20211122_R00EN