

**⚠ WARNING**

Read this Guide thoroughly. It contains important safety information.  
Minimum recommended operators age: 16 years old.  
Keep this Operators Guide in the boat.

# *Operator's Guide*

200, 225, 250, 300 HORSEPOWER



Revision A

***EVINRUDE***<sup>®</sup>  
***E-TEC***<sup>®</sup>





# CALIFORNIA PROPOSITION 65 WARNING

**⚠ WARNING.** This product can expose you to chemicals including gasoline engine exhaust, which is known to the State of California to cause cancer, and carbon monoxide, which is known to the State of California to cause birth defects or other reproductive harm.

For more information go to [www.p65warnings.ca.gov](http://www.p65warnings.ca.gov)

## Operator's Guide

200 / 225 / 250 / 300 HORSEPOWER



Revision A





# Features at a Glance

## Easy to Own and Operate

- 5-Year\* Engine Warranty
- 5-Year Non-Declining Corrosion Warranty
- 5-Years or 500 hours No Scheduled Dealer Maintenance (Normal Recreational Use)
- No Operational Break-In Procedure
- Easy Starts (no choking or priming)
- Digital Engine Management
- Self Flushing Cooling System
- Long Term Storage Design
- Simplified Winterization Procedure
- Digital Diagnostics
- Low Oil Usage

## Durable and Reliable

- Full Corrosion Protection
- *Evinrude E-TEC G2* Lubrication System
- Robust, Heavy-Duty Design
- Extra Capacity Water Pump
- Iridium Spark Plugs
- Vibration Isolated Electronics
- Beltless 50 Amp Charging System
- Stainless Steel Thermostat
- Nickel/Chrome-Faced Piston Rings
- Micro Finished Connecting Rods/Crankshaft

## Cleaner and Quieter

- EPA Emissions Compliance
- European Union Emissions Compliance
- California 3-Star Emissions Compliance
- Sealed Fuel System
- Low Friction Design (No powerhead gears, belts, cams, oil scraping rings, or mechanical oil pump)
- Full Length Insulated Engine Covers
- Quiet Signature Sound
- Air Intake/Silencer
- Idle Air Bypass

*\*3-Years + 2-Year BRP Extended Service Terms (B.E.S.T.)  
Refer to Warranty Statement and B.E.S.T. contract*

The following trademarks are the property of Bombardier Recreational Products Inc. or its affiliates:

*Evinrude®*

*Evinrude® E-TEC® G2*

*Evinrude® Genuine Parts*

*Evinrude® XD100™*

*Evinrude® XD50™*

*RPM Tune™*

*BRP Logo*

*2+4™ Fuel Conditioner*

*HPF Pro™ Gearcase Lubricant*

*PowerSync™*

*Evinrude ICON Touch™*

*S.A.F.E.™*

*SystemCheck™*

*Triple-Guard™ Grease*

*Evinrude ICON II Remote Control*

Printed in the United States.

© 2018 Bombardier Recreational Products Inc. and BRP US Inc. All rights reserved.

® ™ and the BRP logo are trademarks of Bombardier Recreational Products Inc. or its affiliates.

# Table of Contents

|  |           |
|--|-----------|
| <b>About This Guide</b> .....                                  | <b>4</b>  |
| <b>Important Safety Messages</b> .....                         | <b>5</b>  |
| Product References, Illustrations and Specifications .....     | 7         |
| Declaration of Conformity .....                                | 8         |
| <br><b>Using Your <i>Evinrude E-TEC G2</i> Outboard</b>        |           |
| <b>Important On-Product Labels</b> .....                       | <b>10</b> |
| <b>Component Identification</b>                                |           |
| 200, 225, 250, 300 HP 74° V6 .....                             | 12        |
| <b>2–Stroke Engine Oil and Fuel</b> .....                      | <b>14</b> |
| 2–Stroke Engine Oil Requirements .....                         | 14        |
| Oiling System Information .....                                | 14        |
| Fuel Requirements .....  | 15        |
| Fuel System Information .....                                  | 16        |
| <b>Operation</b> .....   | <b>19</b> |
| Safety Information .....                                       | 19        |
| Engine Starting / Stopping .....                               | 19        |
| Remote Controls – <i>Evinrude ICON II</i> Control System ..... | 23        |
| Remote Controls – <i>Evinrude</i> Mechanical Controls .....    | 24        |
| Fuel Economy .....   | 25        |
| <b>Trim, Tilt and Steering</b> .....                           | <b>26</b> |
| Power Trim and Tilt .....                                      | 26        |
| Impact Damage Protection .....                                 | 28        |
| Dynamic Power Steering (DPS) .....                             | 29        |
| <i>iDock</i> Maneuvering System .....                          | 29        |
| <b>Engine Monitoring</b> .....                                 | <b>30</b> |
| Displays and Gauges .....                                      | 30        |
| Speed Adjusting Failsafe Electronics ( <i>S.A.F.E.</i> ) ..... | 30        |
| <b>Special Operating Conditions</b> .....                      | <b>32</b> |
| Cold and Freezing Weather .....                                | 32        |
| Multiple Outboard Operation .....                              | 32        |
| High Altitude .....  | 32        |
| Salt Water .....   | 32        |
| Shallow Water .....  | 32        |
| Under Tow .....  | 32        |
| Weedy Water .....  | 32        |
| <b>Transporting the Outboard</b> .....                         | <b>33</b> |
| Trailerling .....  | 33        |
| Transporting / Storage .....                                   | 34        |

|                                      |    |
|--------------------------------------|----|
| Pre-Ride Inspection .....            | 35 |
| Aquatic Invasive Species (AIS) ..... | 36 |

## Maintenance

|   |    |
|---|----|
| Engine Emissions Installation Information ..... | 40 |
| Maintenance & Inspection Schedule .....         | 42 |
| Engine Care Products .....                      | 42 |
| Service .....                                   | 43 |
| Anodes .....                                    | 43 |
| Flushing .....                                  | 43 |
| Fuses .....                                     | 45 |
| Gearcase Lubricant Level .....                  | 45 |
| Hull Finish .....                               | 45 |
| Outboard External Finish .....                  | 46 |
| Scratch Repair .....                            | 46 |
| Spark Plugs .....                               | 46 |
| Submerged Outboard .....                        | 46 |
| Storage .....                                   | 47 |
| Short-Term Storage .....                        | 47 |
| Long-Term Storage (Winterization) .....         | 47 |
| Troubleshooting .....                           | 49 |
| S.A.F.E. Reset .....                            | 50 |
| Emergency Start Procedure .....                 | 51 |

## Product Information

|   |    |
|---|----|
| Installation .....                            | 54 |
| Transom Height .....                          | 54 |
| Outboard Shipping Cover .....                 | 54 |
| Installing the Outboard .....                 | 55 |
| Boat-Mounted Fuel Filters .....               | 55 |
| Battery .....                                 | 56 |
| Accessory Battery Connection .....            | 57 |
| Water Pressure .....                          | 57 |
| Propeller .....                               | 58 |
| Adjustments .....                             | 59 |
| Specifications .....                          | 60 |
| Product Warranty Information .....            | 63 |
| Readiness Test .....                          | 75 |
| Frequently Asked Questions .....              | 77 |
| Change of Address / Change of Ownership ..... | 79 |
| Confirmation of Receipt .....                 | 81 |

# About This Guide

This Operator's Guide is an essential part of your *Evinrude E-TEC G2* outboard. It contains pertinent information which, if followed, will provide you with a thorough understanding needed for proper operation, maintenance, care, and—above all—safety. Safety is our first priority and it should be yours too. It is strongly recommended you read this Guide from cover to cover. The more you know and understand about your *Evinrude E-TEC G2* outboard, the greater the safety and pleasure you will get from using it. Following this recommendation will assure the completeness of the information essential to your safety, the safety of any passengers, and other water users.

This Operator's Guide identifies important safety messages.

Although the mere reading of such information does not eliminate the hazard, the understanding and application of the information will promote the correct use of your outboard engine.

## Safety Alert Symbol

**This is the Safety Alert symbol. It is used to alert you to potential personal injury hazards. Obey all safety messages that follow this symbol to avoid possible injury or death.**

This Guide should be kept in a waterproof bag with the outboard at all times during operation. If the product ownership is transferred, this Guide should be forwarded to the new owners.

A responsible, educated boater will fully appreciate the pleasures of boating and will be a safe boater. Boating Safety Classes are conducted by the U.S. Coast Guard Auxiliary, the U.S. Power Squadron and some Red Cross Chapters. For information about classes, call toll free 1-800-336-BOAT.

For additional information about boating safety and regulations, call:

- U.S. Coast Guard Boating Safety Hotline  
1-800-368-5647.

Outside North America please contact your Dealer or distributor for details about boating safety.

This Operator's Guide uses the following signal words identifying important safety messages.

## DANGER

Indicates a hazardous situation which, if not avoided, will result in death or serious injury.

## WARNING

Indicates a hazardous situation which, if not avoided, could result in death or serious injury.

## CAUTION

Indicates a hazardous situation which, if not avoided, could result in minor or moderate injury

## NOTICE

Indicates an instruction which, if not followed, could severely damage engine components or other property.

## ENVIRONMENTAL NOTE

A note which provides tips and behaviors related to protecting the environment.

**IMPORTANT:** Identifies information that will help with assembly and operation of the product.

# Important Safety Messages

This Operator's Guide contains essential information to help prevent personal injury and damage to equipment. Safety messages appear throughout this Guide in the applicable section.

Be careful! Human error is caused by many factors: carelessness, fatigue, overload, pre-occupation, unfamiliarity of operator with the product, drugs and alcohol to name a few. Damage to your boat and outboard can be fixed in a short period of time, but injury or death, has a lasting effect.

## **WARNING**

**For your safety and the safety of others, follow all safety warnings and recommendations. Do not disregard any of the safety precautions and instructions.**

**Anyone operating your boat should first read and understand this guide before they operate your boat and outboard.**

### ***SAFETY MEASURES — General***

- To fully appreciate the pleasures, enjoyment and excitement of boating there are some basic rules that should be observed and followed by any boater. Some rules may be new to you and others may be common sense or obvious... irrespective, take them seriously!
- Be sure at least one of your passengers knows how to handle your boat in case of an emergency.
- All passengers should know the location of emergency equipment and how to use it.
- Know the marine traffic laws and obey them.
- All safety equipment and personal flotation devices must be in good condition and suitable for your type of boat. Always comply with the regulations that apply to your boat.
- Remember, gasoline fumes are flammable and explosive. Always adhere to the fueling procedure contained in this Operator's Guide and those given to you by the fueling station. Always verify fuel level before use and during the ride. Apply the principle of 1/3 fuel to destination, 1/3 back and 1/3 reserve fuel supply. Do not carry spare fuel or flammable liquids in any storage or engine compartments.
- Whenever running the engine, assure there is proper ventilation to avoid the accumulation of carbon monoxide (CO), which is odorless, colorless, and tasteless, and can lead to unconsciousness, brain damage, or death if inhaled in sufficient concentrations. CO accumulation can occur while docked, anchored, or underway, and in many confined areas such as the boat cabin, cockpit, swim platform, and heads. It can be worsened or caused by weather, mooring and operating conditions, and other boats. Avoid exhaust fumes from your engine or other boats, provide proper ventilation, shut off your engine when not needed, and be aware of the risk of backdrafting and conditions that create CO accumulation. In high concentrations, CO can be fatal within minutes. Lower concentrations are just as lethal over long periods of time.
- Avoid standing up or shifting weight suddenly in light weight boats.
- Keep your passengers seated in seats. The boat's bow, gunwale, transom and seat backs are not intended for use as seats.
- Insist on the use of personal flotation devices, approved by the U.S. Coast Guard, by all passengers when boating conditions are hazardous, and by children and nonswimmers at all times.

## **Safety Measures — Installation and Maintenance**

- Proceed with caution and at very low speed in shallow water. Grounding or abrupt stops may result in personal injury or property damage. Also be alert for debris and objects in the water.
  - Be familiar with the waters you are operating in. The gearcase of this outboard extends below the water surface and could potentially come in contact with underwater obstructions. Contact with underwater obstructions may result in loss of control and personal injury.
  - Respect no wake zones, rights of other water users and the environment. As the "skipper" and owner of a boat you are responsible for damage to other boats caused by the wake of your boat. Allow no one to throw refuse overboard.
  - Do not operate your boat if you are under the influence of drugs or alcohol.
  - High performance boats have a high power-to-weight ratio. If you are not experienced in the operation of a high performance boat, do not attempt to operate one at, or near, its top speed until you have gained that experience.
  - Become completely familiar with the control and operation of your boat and outboard before embarking on your first trip or taking on a passenger(s). If you have not had the opportunity to do so with your Dealer, practice driving in a suitable area and feel the response of each control. Be familiar with all controls before applying the throttle above idle speed. As the operator, you are in control and responsible for safe operation.
- The outboard must be correctly installed. Failure to correctly install the outboard could result in serious injury, death or property damage. BRP recommends that your Dealer install your outboard to ensure proper installation.
  - Do not overpower your boat by using an engine that exceeds the horsepower indicated on the boat's capacity plate. Overpowering could result in loss of control. If your boat has no capacity plate, contact your Dealer or the boat's manufacturer.
  - When replacement parts are required, use *Evinrude Genuine Parts* or parts with equivalent characteristics, including type, strength and material. Using sub-standard parts could result in injury or product malfunction.
  - Only perform service procedures which are detailed in this Operator's Guide. Attempting to perform maintenance or repair on your outboard if you are not familiar with the correct service and safety procedure could cause personal injury or death. Further information can be obtained from your authorized *Evinrude* Dealer. In many instances proper tools and training are required for certain service or repair procedures.
  - Maintain your boat and engine in top condition at all times. Adhere to the **Maintenance & Inspection Schedule** on page 42.
  - Operate your boat and outboard prudently and have fun. Do not forget that all persons must assist other boaters in case of emergency.
  - Prevent injury from contact with rotating propeller; remove propeller before flushing or before performing any maintenance.

## Product References, Illustrations and Specifications

BRP reserves the right to make changes at any time, without notice, to features, specifications and model availability, and to change any specification or part at any time without incurring any obligation to update older models. The information in the Guide is based on the latest specifications available at the time of publication.

Photographs and illustrations used in this Guide might not depict actual models or equipment but are intended as representative views for reference only.

Certain features of systems discussed in this Guide might not be found on all models in all marketing areas.

### ***Owner's Identification***

**United States and Canada** — At the time of purchase, your Dealer will complete your outboard registration forms. Your portion provides proof of ownership and date of purchase.

**Outside United States and Canada** — See your Dealer or distributor for details.

### ***Model and Serial Numbers***

The model and serial numbers appear on a plate attached to the stern bracket or swivel bracket. Record your outboard's:

Model Number \_\_\_\_\_

Serial Number \_\_\_\_\_

Purchase Date \_\_\_\_\_

Ignition Key Number \_\_\_\_\_

### ***Stolen Outboards***

**United States and Canada** — Report stolen outboards to your local dealer or distributor.

**Outside United States and Canada** — Report the theft to the Bombardier Recreational Products distributor where the outboard was registered.

### ***Technical Literature***

BRP offers technical literature specifically for your outboard. A service manual, or an extra Operator's Guide can be purchased from your selling Dealer. For the name and location of the nearest *Evinrude* Dealer in the United States and Canada visit **[www.evinrude.com](http://www.evinrude.com)**.

## **Declaration of Conformity**

The EC Declaration of Conformity does not appear in this version of the Operator's Guide. Please refer to the printed version that was delivered with your engine.



---

**Using Your  
*Evinrude E-TEC G2*  
Outboard**

## Important On-Product Labels

This outboard comes with hang tags and labels containing important safety information about the operation of the outboard. Any person who operates this outboard should read and understand this safety information.

### Labels

All outboards have the following labels attached:

### Warning Symbols

The following symbols are used together to indicate “CAUTION: Read the engine’s Operator’s Guide before proceeding.”

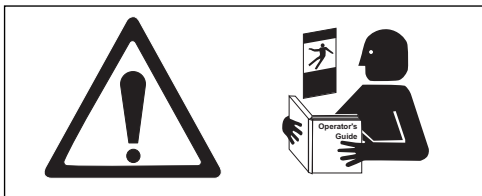

1. Read Operator’s Guide Label

355633

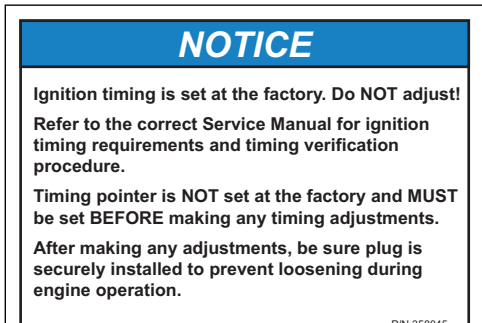

2. Ignition Timing Notice Label

0358045



3. Warning Label

0358046

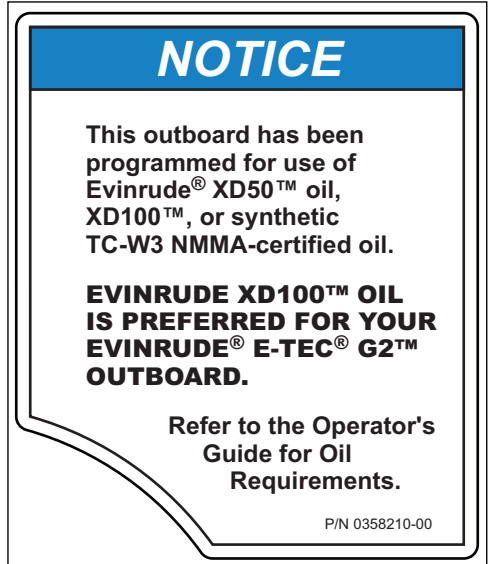

4. Oil Usage Notice Label

0358210



5. Emissions Control Label

5008922

### Manufacturing Date

A two-character code is used to indicate the month and year of manufacture, following the U.S. EPA model year naming convention.

- The first character is the year.
- The second character is the month (January = A, February = B, March = C, etc.).

For more information about Family Naming Conventions for Vehicles and Engines, go to:

<https://www.epa.gov/vehicle-and-engine-certification/information-about-family-naming-conventions-vehicles-and-engines>

## Hang Tag

All outboards are shipped with the following hang tag attached.

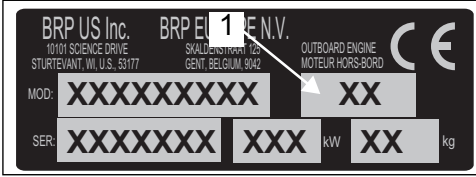

### 6. Serial / Model Number Label

1. Manufacturing date code

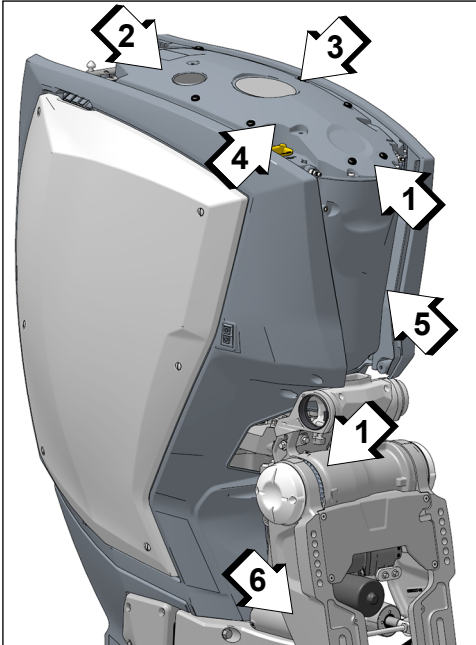

#### Label Locations

1. Read Operator's Guide Label
2. Ignition Timing Notice Label (remove top cover)
3. Warning Label (remove top cover)
4. Oil Usage Label (remove top cover)
5. Emissions Control Label (remove front cover)
6. Serial / Model Number Label

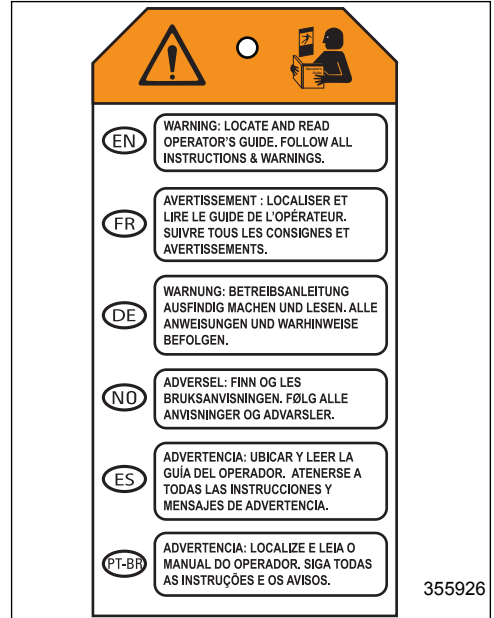

## Remote Control Labels

All mechanical remote controls have the following labels attached.

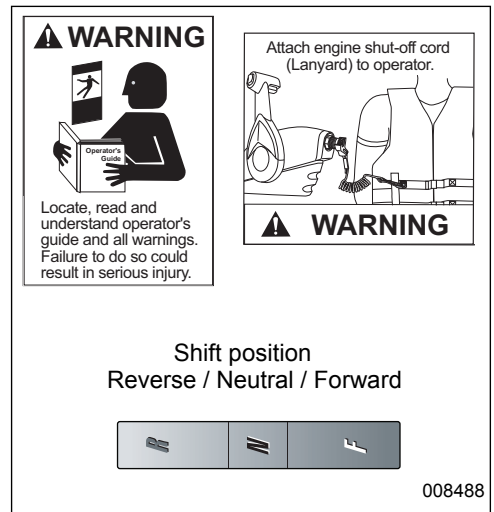

008488

## Component Identification

### 200, 225, 250, 300 HP 74° 3.4 L V6

**NOTE:** Some engine safety labels are not shown on illustrations. For information on engine safety labels, refer to **Important On-Product Labels** on page 10.

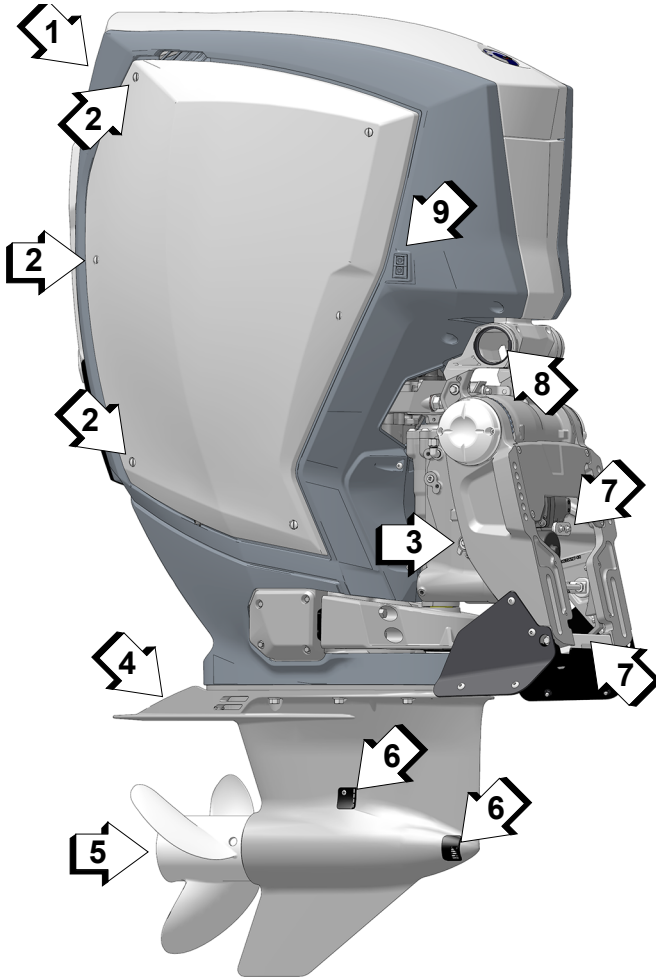

009041

| Item | Description             | Item | Description                |
|------|-------------------------|------|----------------------------|
| 1    | Air Inlet               | 6    | Water Intake Screens       |
| 2    | Cover Fasteners (6)     | 7    | Anodes                     |
| 3    | Tilt Support Lever      | 8    | Rigging Center cable entry |
| 4    | Anode                   | 9    | Trailing Tilt Switch       |
| 5    | Anode (propeller shaft) |      |                            |

### Starboard

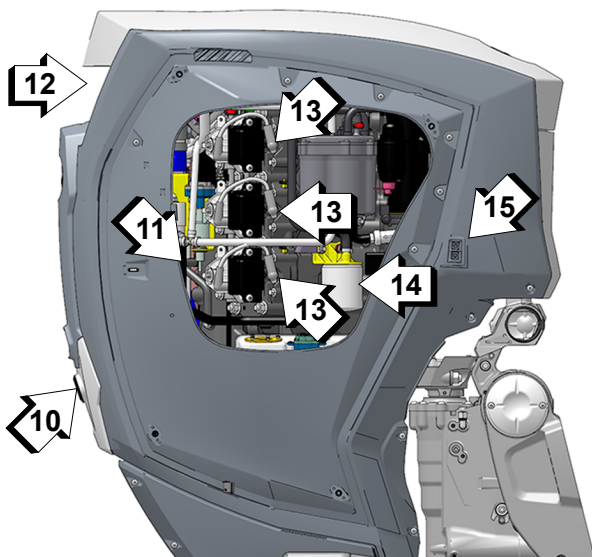

009042

### Port

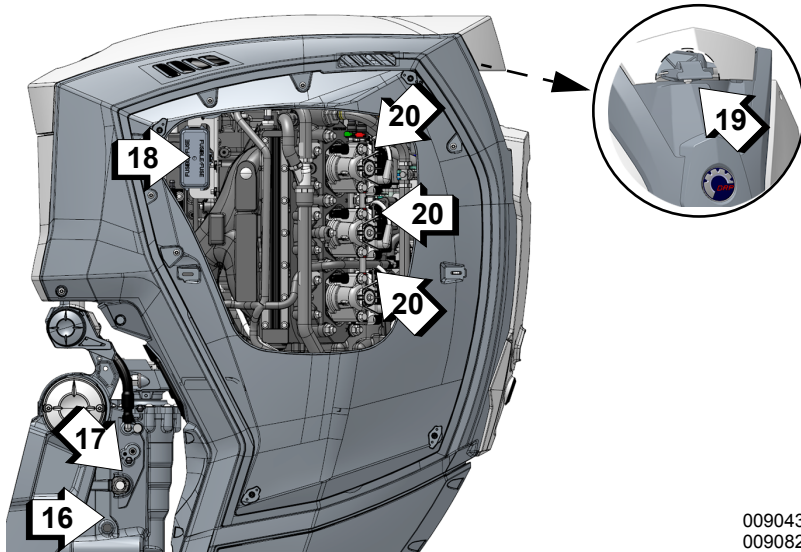

009043  
009082

| Item | Description                          | Item | Description          |
|------|--------------------------------------|------|----------------------|
| 10   | Water Pump Indicator, Flushing Port  | 16   | Manual Release Valve |
| 11   | Gearcase Oil Reservoir (Check Level) | 17   | Trim and Tilt Fill   |
| 12   | Air Inlet                            | 18   | Fuse Box             |
| 13   | Spark Plugs                          | 19   | Top Cover Latch      |
| 14   | Fuel Filter                          | 20   | Spark Plugs          |
| 15   | Trailing Tilt Switch                 |      |                      |

## 2-Stroke Engine Oil and Fuel

### 2-Stroke Engine Oil Requirements

#### NOTICE

When operating in conditions under 32°F (0°C), *Evinrude XD100* oil must be used.

#### **Evinrude Brand Oils**

*Evinrude XD* 2-stroke outboard oils are formulated to give best engine performance while controlling piston and combustion chamber deposits, providing superior lubrication, and ensuring maximum spark plug life.

The following 2-stroke outboard oils are recommended for use in your *Evinrude E-TEC G2* outboard:

- *Evinrude XD100* Direct Injection Oil
- *Evinrude XD50* 2-Stroke Oil
- or a synthetic TC-W3 NMMA-certified oil

***Evinrude XD100* oil is preferred for your *Evinrude E-TEC G2* outboard.** This synthetic formula oil provides uncompromised lubrication and superior performance, even in extreme conditions especially in cold temperatures down to 0°F (-17°C).

#### NOTICE

**DO NOT add automotive type 4-stroke oils to 2-stroke engine oil tank(s).**

**Do not add oil to the fuel.**

Failure to follow oil specifications could void the engine warranty if a lubrication-related failure occurs.

### Oiling System Information

If a “LOW OIL” warning occurs, you have a limited amount of time of normal operation before running out of oil. Refill the oil tank with approved oil as soon as possible.

Refer to **Engine Monitoring** on page 30.

To check oil level:

- Trim outboard to the vertical position.
- Use a digital display or gauge to check the oil tank level.

Always “top off” your oil tank prior to prolonged usage or long trips. You may want to keep an extra supply of outboard oil in the boat.

New outboards are programmed to use additional oil during the first two hours of operation above 2000 RPM.

If you run the oil tank empty, REFILL the oil tank and prime the oil system before using the engine. Refer to **Filling the On-Engine Oil Tank** on page 15 and **Priming the Oil System** on page 15.

If an accessory remote oil tank is installed and the oil hose is disconnected for any reason, seal it to prevent spillage. Install a cap on the hose fitting to prevent contamination.

#### **Oil Tank Capacity**

The on-engine oil tank capacity is 2.0 gallons (7.5 liters).

#### **Optional Remote Oil Tank**

The following optional accessory remote oil tank kits are available:

- 1.8 gallons (6.8 liters)
- 3.0 gallons (11.3 liters)
- An oil tank pick-up kit is also available for the 10 gallon (37.8 liters) capacity oil tank.

Install the optional remote oil tank following the instructions provided with the unit.

## Filling the On-Engine Oil Tank

Remove the top cap of the engine cover. Next, remove the oil fill cap. Fill the oil tank with outboard lubricant. Oil capacity is 2 gallons (7.5 liters)

Replace the filler cap and tighten securely. If you run the tank empty, you **MUST** prime the oil system before using the engine.

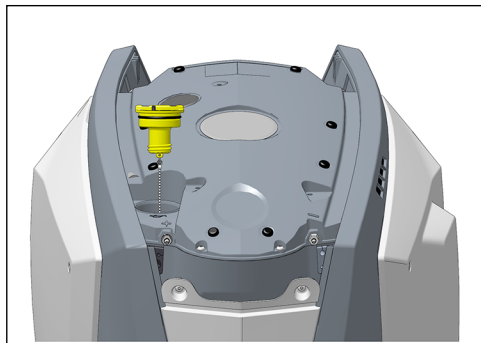

Oil Fill Cap

009044

## Priming the Oil System

The oil system of *Evinrude E-TEC G2* outboards is primed at the factory.

Priming the oil system is only required if:

- The oil system is disassembled for service or parts replacement; or
- The oil tank is run out of oil.

**NOTE:** If the oil tank is run out of oil, the *EMM* will activate SHUT DOWN mode and set Fault Code 33. See “NO OIL” on page 31.

After refilling an empty oil tank or servicing the oil system, air **MUST** be removed from the oil system before operating the outboard.

Prime the oil system by performing the **Long-Term Storage (Winterization)** on page 47 **TWO** times.

If available, *Evinrude Diagnostic* software v 6.1 or higher may be used to prime the oil system **ONE** time.

## Fuel Requirements

### ⚠ WARNING

**Gasoline is extremely flammable and highly explosive under certain conditions. Follow the instructions in this section explicitly. Improper handling of fuel could result in property damage, serious injury or death.**

**Leaking fuel is a fire and explosion hazard. All parts in the fuel system should be inspected frequently and replaced if signs of deterioration or leakage are found. Inspect the fuel system each time you refuel, each time you remove the engine cover and annually.**

### NOTICE

**Always use fresh gasoline. Gasoline will oxidize; the result is loss of octane, volatile compounds, and the production of gum and varnish deposits which can damage the fuel system.**

Fuel blending varies by country and region. Your outboard has been designed to operate using the recommended fuels; however, be aware of the following:

- The boat's fuel system may have different requirements regarding the use of alcohol fuels. Refer to the boat's owner guide.
- Alcohol blended fuels attract and hold moisture which may lead to fuel phase separation and can result in engine performance problems or engine damage.
- Use of fuel containing alcohol above the percentage specified by government regulation can result in the following problems in outboard engines and fuel system components:
  - Vapor lock or fuel starvation
  - Starting and operating difficulties
  - Deterioration of rubber or plastic parts
  - Corrosion of metal parts
  - Damage to internal engine parts
- Have your dealer inspect for fuel leaks or other fuel system abnormalities if you suspect the presence of alcohol in gasoline exceeds the current government regulation limits.

## Using Your Evinrude E-TEC G2 Outboard

**Recommended Fuel:** Use unleaded gasoline with an AKI (R+M)/2 octane rating of 87, or an RON octane rating of 90.

### **Biobutanol (Bu16) Fuel**

Biobutanol is a four-carbon alcohol produced from renewable, plant-derived energy sources in a fermentation process similar to beer and wine production. Biobutanol delivers more renewable energy content than ethanol while remaining compatible with current vehicles, boats, and infrastructure. Biobutanol does not phase separate in the presence of water like ethanol and is less corrosive to fuel system components such as fuel tanks, fuel fittings and fuel hoses.

Biobutanol blended fuel (either isobutanol or n-butanol) may be used in all *Evinrude* outboards. Use of biobutanol blended fuel will NOT void the warranty of *Evinrude* outboards. Biobutanol blended fuel (Bu16 - up to 16.1% by volume) has been approved for use by the *National Marine Manufacturers Association (NMMA)*.

### **Use in North America**

#### **NOTICE**

**Do NOT use fuel from fuel pumps labeled E85. Never experiment with other fuels.**

The use of unleaded gasoline containing alcohol above the percentage specified by government regulations is not recommended. Use of fuel labeled E15 is prohibited by U.S. EPA Regulations.

Use of a boat mounted water separating fuel filter is strongly recommended.

### **Use Outside North America**

The use of unleaded gasoline containing alcohol above the percentage specified by local government regulations is not recommended.

Use of a boat mounted water separating fuel filter is strongly recommended.

### **Use In the European Union**

Deployment of Alternative Fuels Infrastructure Directive 2014/94/EU.

This directive provides harmonized labeling across Europe to effectively assist consumers in identifying the compatibility of fuels supplied at refueling points with an engine.

All *Evinrude* outboards are compatible with up to 10% ethanol fuel blends (E10). The decal shown below should be present near the fuel filler cap of all recreational vessels.

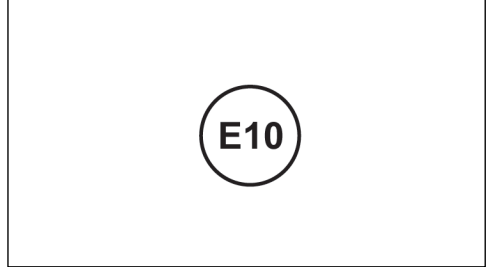

Decal

0361860

## **Fuel System Information**

In the United States, the U.S. EPA requires low permeability fuel hose, fuel primer bulbs, portable fuel tanks and fuel caps to be used with outboard engines.

**IMPORTANT:** Fuel distribution hoses in the boat must deliver fuel at a specific flow rate. Minimum inside diameter of fuel hoses must be 3/8 in. (9 mm).

Fuel systems with built-in tanks, particularly those that include antisiphon valves and filter/primer units, may have restrictions not allowing the engine fuel pump to deliver sufficient fuel under all conditions. This can result in a loss of performance. If a performance problem exists, see the **Service Note** on page 51.

### **Fuel Hose Connections**

- 1) If the fuel hose is disconnected for any reason, seal the hose and fitting to prevent spillage. or contamination.
- 2) Connect the fuel hose to the 3/8 in. (9 mm) fuel fitting. Fasten hose securely with the 18.5 mm clamp from owner's kit.



## Fueling Procedure

### WARNING

Fuel is flammable and explosive under certain conditions. Follow these instructions to ensure safety when handling fuel:

- Always work in a well ventilated area.
- Always turn off the engine before fueling.
- Never permit anyone other than an adult to refill the fuel tank.
- Do not smoke, or allow open flames, or sparks or use electrical devices such as cellular phones in the vicinity of a fuel leak or while fueling.
- When fueling, keep boat level.
- Remove portable fuel tanks from the boat before fueling.
- Fuel tank may be pressurized, turn cap slowly when opening.
- Do not overfill or top off the fuel tank and leave boat in the sun. As temperature increases, fuel expands and might overflow.
- To prevent fuel back-flow, fill the fuel tank slowly so air can escape from tank.
- Always wipe off any fuel spillage.

### ENVIRONMENTAL NOTE

Dispose of fuel contaminated towels in an environmentally responsible manner, or according to local regulations.

Do NOT add 2-stroke engine oil to the fuel.

### *On a Trailer*

- 1) Make sure the boat is level.
- 2) Slowly turn the fuel tank cap counterclockwise to remove it.
- 3) Insert the gas pump nozzle into the filler neck of the fuel tank and fill the fuel tank.
- 4) Stop filling immediately when the automatic shut-off feature of the gas pump handle activates.
- 5) Wait a moment before removing the gas pump nozzle from the filler neck. Do not retract the gas pump nozzle from the filler neck to top off the fuel tank.

- 6) Install the fuel tank cap and turn clockwise to fully tighten it.

### *In the Water*

- 1) Turn off engine.
  - 2) Tie boat securely to the fueling pier.
  - 3) Do not allow anyone to remain in or on the boat.
  - 4) Have a fire extinguisher close at hand.
  - 5) Slowly turn the fuel tank cap counterclockwise to remove it.
  - 6) Insert the gas pump nozzle into the filler neck of the fuel tank and fill the fuel tank.
  - 7) Stop filling immediately when the automatic shut-off feature of the gas pump handle activates.
  - 8) Wait a moment before removing the gas pump nozzle from the filler neck. Do not retract the gas pump nozzle from the filler neck to top off the fuel tank.
- Install fuel tank cap and turn clockwise to fully tighten it.

### Fuel Additives

#### **NOTICE**

**Use of other fuel additives can result in poor performance or engine damage.**

The only fuel additives approved for use in your *Evinrude E-TEC G2* outboard are:

- *Evinrude 2+4 Fuel Conditioner*
- *Evinrude Fuel System Cleaner*

*Evinrude 2+4 Fuel Conditioner* will help prevent gum and varnish deposits from forming in fuel system components and will remove moisture from the fuel system. It can be used continuously and should be used during any period when the outboard is not being operated on a regular basis. Its use will reduce spark plug fouling, fuel system icing, and fuel system component deterioration.

*Evinrude Fuel System Cleaner* will help keep fuel injectors in optimal operating condition.

#### ***Fuel System Priming***

If the outboard is run out of fuel, refill the fuel tank. Turn the key switch to the ON position to activate the fuel pump.

# Operation

## Safety Information

### **⚠ DANGER**

Serious injury or death can result from contact with a rotating propeller or moving boat and outboard.

Propeller blades can be sharp and the propeller can continue to turn even after the engine is off.

Assure the engine propeller area is clear of people and objects before starting engine or operating the boat.

Be alert of people in the water.

Always shift the outboard to **NEUTRAL** and shut off the engine immediately when your boat is in an area where there might be people in the water.

### **⚠ DANGER**

**DO NOT** run the engine indoors or without adequate ventilation or permit exhaust fumes to accumulate in confined areas. Engine exhaust contains carbon monoxide which, if inhaled, can cause serious brain damage or death.

### **⚠ WARNING**

The engine cover is a machinery guard. **DO NOT** operate your outboard with the cover off unless you are performing maintenance. Be careful to keep hands, hair, and clothing clear of all moving parts. Contact with moving parts could cause injury.

### **⚠ WARNING**

Be familiar with the waters you are operating in. The gearcase of this outboard extends below the water surface and could potentially come in contact with underwater obstructions. Contact with underwater obstructions may result in loss of control and personal injury.

## Engine Starting / Stopping

Refer to the **Pre-Ride Inspection** on page 35. Complete the inspection before using your *Evinrude E-TEC G2* outboard.

### **NOTICE**

**You MUST supply water to the engine before attempting to start it. Engine damage can occur quickly.**

Be sure the water intake screens are below the water surface.

### **Engine Cut-off Switch/Key Switch**

A combination engine cut-off switch and key switch is a feature of *Evinrude* prewired remote controls and all *Evinrude* control wiring kits. Use of the engine cut-off switch feature is highly recommended on all boats.

Connect the clip to the engine cut-off switch/key switch.

If boat is equipped with a second station, connect the clip to the second station cut-off switch.

**IMPORTANT:** The second station clip **MUST** be installed. The outboard cannot be started if the second station clip is not in place.

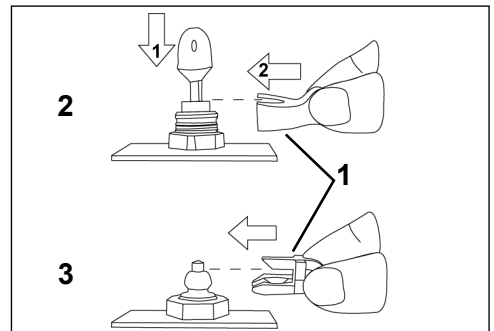

1. Clip
2. Engine cut-off switch/key switch
3. Second station cut-off switch

009045

## **⚠ WARNING**

**Always use the tether cord when operating your boat to help prevent a runaway boat and reduce the risk of personal injury or death**

In an emergency situation, the engine can be started without the clip installed on the key switch. Follow the normal starting procedure. Reinstall a clip as soon as possible. **The operator should always use the clip and tether cord anytime the engine is running.** Refer to **Engine Cut-off Switch/Key Switch** on page 19.

## **⚠ WARNING**

**Avoid knocking or pulling the clip off the engine cut-off switch during normal boating. Avoid bumping the key if operating without the clip on the switch. The resulting unexpected loss of forward motion can throw occupants forward, causing injury.**

**Keep the tether cord free from obstructions and entanglements.**

**At each outing, test the system's operation. With the engine running, remove the clip from the switch by pulling the tether cord. If the engine does not stop running, see the Service Note on page 45.**

**IMPORTANT:** Your engine cut-off switch can be effective only when in good working condition. At each outing, inspect clip and tether cord for cuts, breaks, or wear. Replace worn or damaged parts.

Snap the tether cord to a **secure** place on the operator's clothing or life vest — not where it

might tear away instead of activating the engine cut-off switch.

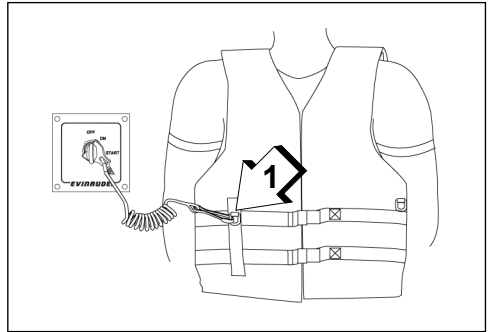

1. Tether cord

009046

Disconnecting the clip and tether cord will stop the engine and prevent the boat from becoming a runaway if the driver moves beyond the range of the tether cord. If the tether cord is too long, it can be shortened by knotting or looping it. **DO NOT** cut and retie the tether cord.

## **NOTICE**

**Carefully check the function of all control and engine systems before leaving the dock.**

Move the remote control handle to NEUTRAL.

Set control to SLOWEST speed position.

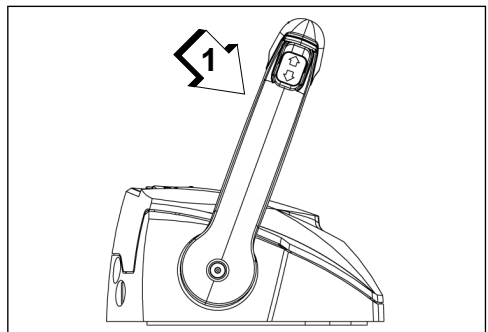

1. SLOWEST speed position

009047

**DO NOT** advance the throttle before start-up. Advancing the throttle overrides the electronic idle control system.

If the outboard is started with the throttle advanced, the outboard will be in a safety mode.

It will not respond to throttle until the throttle is returned to slowest IDLE position

After the engine starts, the engine management module (EMM) automatically increases idle speed slightly. Idle speed will decrease as the engine warms up.

### Engine Starting

**IMPORTANT:** If equipped with *Evinrude ICON II* Remote Control System, refer to **Remote Controls — Evinrude ICON II Control System** on page 23.

Turn the key switch to the on position, then:

**Single engine applications** — turn the key fully clockwise to the START position.

**Multiple engine applications** — Push and hold the START button(s).

If the engine did not start, release the key or button momentarily, then try again.

Each time the key switch is turned from OFF to ON, the warning system will self-test. Refer to **Engine Monitoring** on page 30.

If your outboard does not react normally to this starting procedure or if it fails to start, refer to **Troubleshooting** on page 49.

### After Engine Starts

The engine monitoring system will alert you of any abnormalities.

### Engine Stopping

Move control handle to NEUTRAL.

**Multiple engine applications** — Briefly push the STOP buttons.

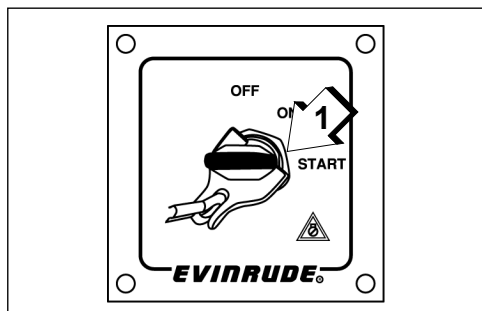

1. Key switch START position 009048

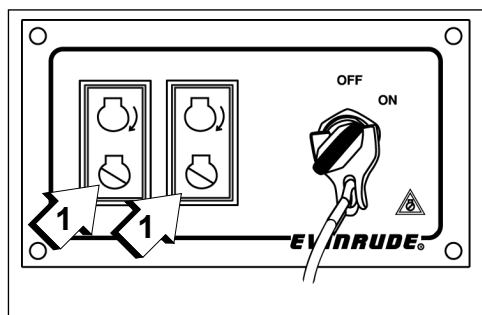

1. Stop buttons 009158

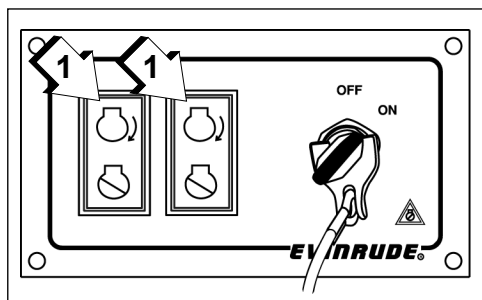

1. Start buttons 009158

Upon start-up, release the key or buttons.

## Using Your Evinrude E-TEC G2 Outboard

**All applications** — Or turn key switch counterclockwise to the OFF position.

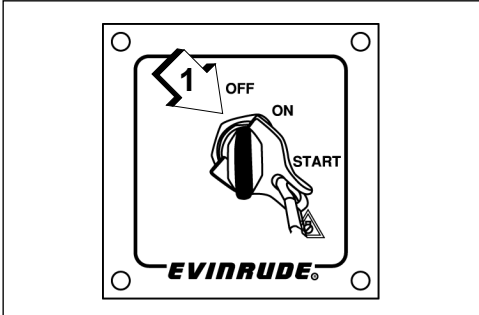

1. Key switch, OFF position

009049

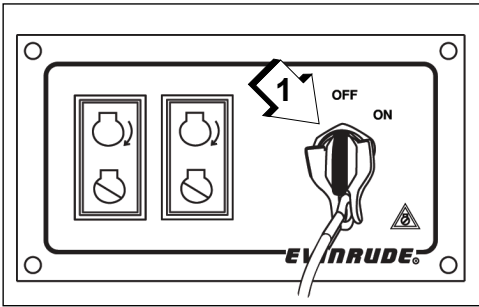

1. Key switch, OFF position

009159

Remove the key when the boat will be unattended. 44

## Remote Controls — Evinrude ICON II Control System

### ICON II User's Guide

**IMPORTANT:** For complete information about using *ICON II* remote control systems, refer to the “*ICON II User's Guide*”.

### Remote Control Selection

*Evinrude ICON II* is an intelligent, electronic shift and throttle control system for use with *Evinrude E-TEC G2* outboards. *ICON II* control systems are available for up to four-engine installations. The *ICON II* control system supports dual station and “flying bridge” applications.

### ICON II Remote Control Features

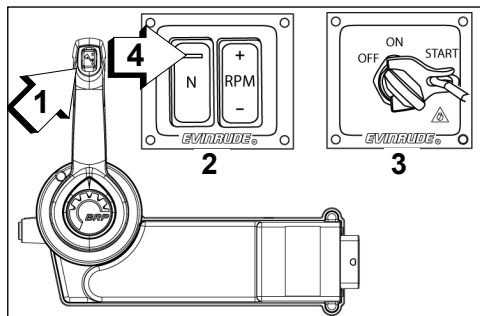

Concealed Side Mount *ICON II* Control 009052

1. Trim/tilt switch
2. RPM switch panel
3. OFF/ON/START switch
4. NEUTRAL Indicator LED

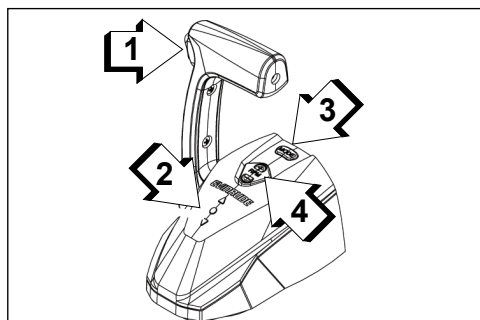

Single Binnacle *ICON II* Control 009053

1. Trim/tilt switch
2. Gear position indicators
3. Neutral button
4. RPM Tune button

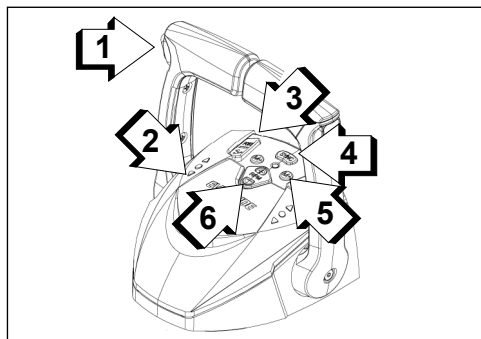

Dual Binnacle *ICON II* Control 009054

1. Master Trim/tilt switch
2. Gear position indicators
3. Individual engine trim switches
4. SYNC button
5. Mode button
6. RPM Tune button

### Shifting

With engine running and control handle in NEUTRAL:

Move the control handle forward or aft until it engages the forward or reverse gear detent.

### Speed Control

After gear engagement, move the control handle slowly in the same direction to increase speed.

Press the **RPM + or -** button to fine tune engine speed up or down in 1% increments.

### Engine Synchronization (Dual Binnacle Only)

Press the **SYNC** button to automatically synchronize the RPM of multiple engines. The **SYNC** button also transfers control of all engines to the port lever on the control.

### Multiple Outboard Installations

#### *iDock User's Guide*

For boats equipped with the *Evinrude iDock* maneuvering system for two outboards, refer to the “*iDock User's Guide*” for complete information about using the *iDock* system.

## Remote Controls - Evinrude Mechanical Controls

### ⚠ WARNING

If you choose a non-Evinrude remote control, it must have a start-in-gear prevention feature. This feature can prevent injuries resulting from unexpected boat movement when the engine starts.

Use of a mechanical remote control requires an accessory mechanical to digital shift and throttle converter.

**IMPORTANT:** When selecting the remote control system for your boat, specify *Evinrude* components. *Evinrude* controls incorporate safety and convenience features as:

- Start-in-gear prevention
- Plug-in compatibility with *Evinrude* Modular Wiring System (MWS)

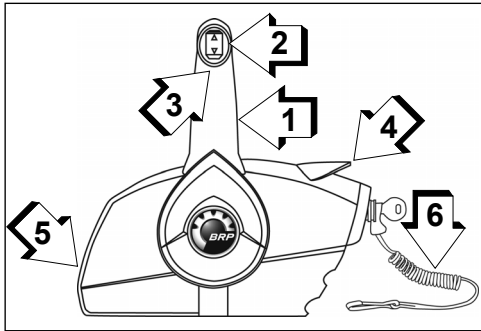

Side Mount Control

006448

1. Handle – shift and throttle
2. Trim/tilt switch (where equipped)
3. Neutral lock lever
4. Fast idle lever (warm-up)
5. Throttle friction adjusting screw
6. Engine cut-off switch clip and tether cord

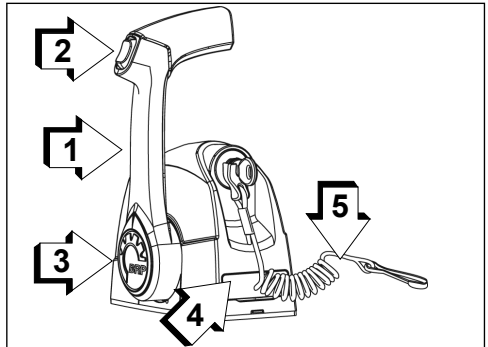

Single Lever Binnacle Mount Control

006446

1. Handle – shift and throttle
2. Trim/tilt switch (where equipped)
3. Fast idle button (warm-up)
4. Throttle friction adjusting screw (under cover)
5. Engine cut-off switch clip and tether cord

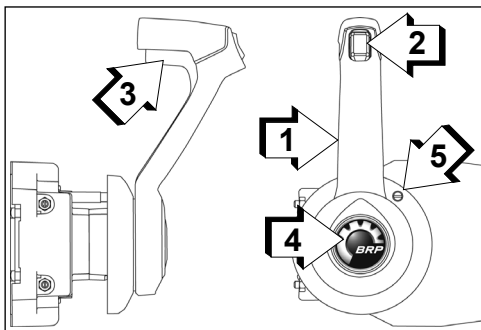

Concealed Side Mount Control

006447

1. Handle – shift and throttle
2. Trim/tilt switch (where equipped)
3. Neutral lock lever
4. Fast idle button (warm-up)
5. Throttle friction adjusting screw

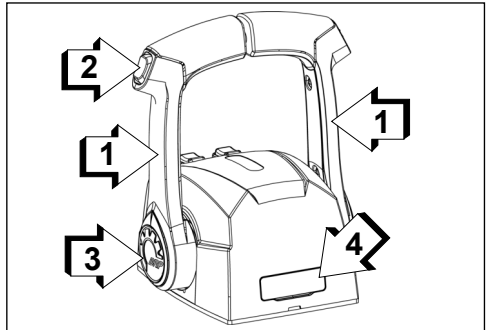

Dual Lever Binnacle Mount Control

006445

1. Handle – shift and throttle
2. Trim/tilt switch (where equipped)
3. Fast idle button (warm-up)
4. Throttle friction adjusting screw (under cover)



## Shifting

With engine running and control handle in NEUTRAL:

### Side Mount Controls

Unlock the control handle by lifting the neutral lock lever on the hand grip. Move the control handle with a firm, quick motion, forward or aft until it engages the forward or reverse gear detent.

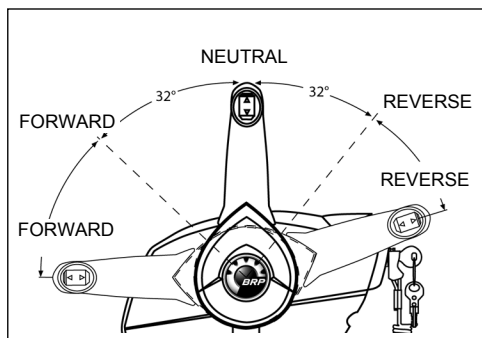

004854

### Binnacle Mount Controls

Move the control handle with a firm, quick motion, forward or aft until it engages the forward or reverse gear detent.

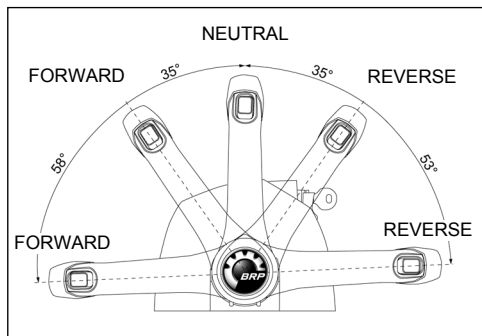

005502

## Speed Control

After gear engagement, move the control handle slowly in the same direction to increase speed.

## Fuel Economy

Fuel economy can vary depending on boat load, hull design, and throttle setting. When boat reaches top speed, throttle back from FULL SPEED to a lower throttle setting. You can save fuel with a minimal loss of speed.

If equipped, use the “fuel economy” feature of digital displays or gauges to optimize fuel consumption. Refer to the user’s guide for the digital display.

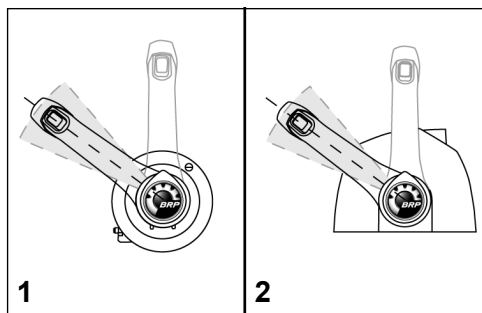

Typical Fuel Economy Throttle Range

1. Side mount control
2. Binnacle mount control

008490

## Trim, Tilt and Steering

### Power Trim and Tilt

The trim and tilt functions of *Evinrude E-TEC G2* outboards are controlled by the engine *EMM*.

**IMPORTANT:** Activating any trim button while the key switch is in the OFF position will briefly turn on the system. This will cause the electric fuel pump to run and the remote control and any displays or gauges to turn on. There will be a short delay before the trim system operates. This is normal. The system will turn off after a few seconds of non-use.

#### **⚠ WARNING**

**When operating in rough water or crossing a wake, excessive bow-up trim may result in the boat's bow suddenly rising skyward, possibly ejecting or otherwise seriously injuring occupants.**

**Some boat/outboard/propeller combinations may encounter boat instability and/or high steering torque when operated at high speed at or near the outboard's trim range limits (full bow-up or bow-down). Boat stability and steering torque can also vary due to changing water conditions. If any adverse conditions occur, reduce throttle and/or adjust trim angle to maintain control. If you experience boat instability and/or high steering torque, see your Dealer to correct these conditions.**

Some boats plow, or are difficult to plane, when operated in the lowest trim position. If your boat handles unsuitably when trimmed fully bow-down, adjust the trim.

#### **⚠ WARNING**

**If the bow of the boat plows the water at high speeds, the boat may bow steer or spin suddenly, possibly ejecting or otherwise seriously injuring occupants.**

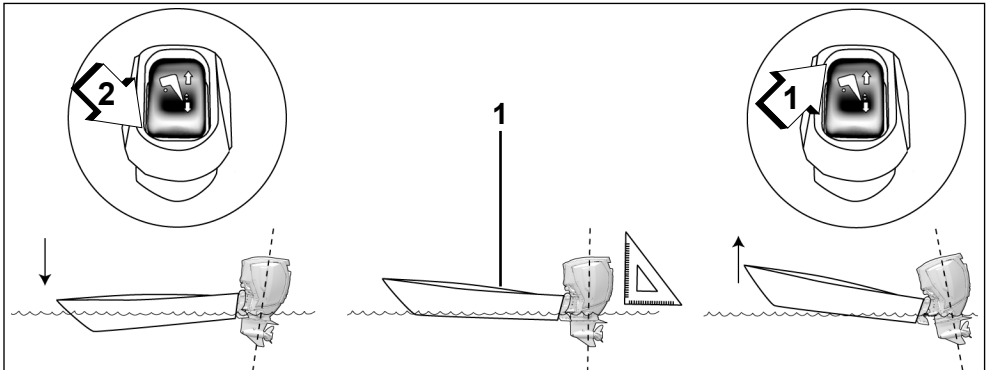

009055

1. Parallel to the surface of the water
2. Trim switch, DOWN
3. Trim switch, UP

The boat should accelerate quickly, plane easily, and run parallel to the surface of the water at high speeds.

- If trim position is too LOW the front of boat will be DOWN and push water.
- If trim position is too HIGH the front of boat will be UP and bounce.

## *iTrim*

Your outboard is equipped with *iTrim*, a trim assist feature. By default, this feature is disabled from the factory.

Use the *Evinrude ICON-Touch* or *ICON CS* digital display to enable *iTrim*. If your boat is not equipped with an *ICON* digital display, your Dealer must use *Evinrude Diagnostic* software to enable this feature.

To activate the *iTrim*:

- the key switch must be in the ON position
- use the trim/tilt switch to trim the engine to the full DOWN position.

During operation, the outboard will automatically trim up or down to an acceptable trim angle based on pre-programmed parameters.

Use the trim/tilt switch on the control lever to fine tune to an optimum trim angle.

**IMPORTANT:** Use of the trim/tilt switch to manually adjust the outboard trim angle will temporarily deactivate *iTrim*.

To reactivate *iTrim*:

- use the trim/tilt switch to trim the engine to the full down position
- bring the engine to idle speed.

## *Trim*

In most operating conditions, it is recommended to trim the outboard to the full down position while accelerating. As the boat comes on plane, trim the outboard up for best performance.

Run the boat in the water to determine the best trim angle.

Over-trimming increases engine RPM while decreasing speed. The best trim setting is when the highest speed is achieved with the lowest engine RPM.

**IMPORTANT:** Weight distribution can affect the performance of the boat. Distribute weight evenly in the boat.

## *Trim Angle Adjustment*

Use the trim/tilt switch to adjust the outboard position in the tilt range or trim range.

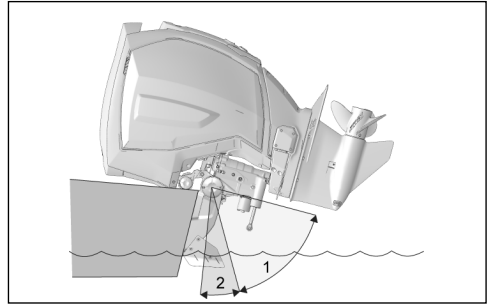

1. Tilt range
2. Trim range

009056

## *Shallow Water*

### **NOTICE**

**When operating a tilted outboard, do not run above a fast idle speed. Keep the water intakes submerged at all times to prevent the engine from overheating.**

Adjust the outboard position within the tilt range for shallow water operation.

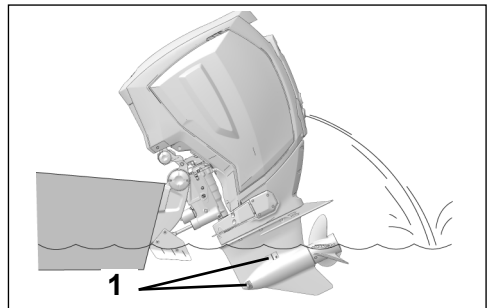

1. Water intakes

009057

## *Tilt*

The tilt range allows the operator to tilt the outboard for clearance when beaching, mooring, launching, or trailering.

## *Tilt Limit*

See **Adjustments** on page 59, if your outboard contacts the boat's motor well while tilting.

# Using Your Evinrude E-TEC G2 Outboard

## Manual Release Valve

If needed, the outboard will tilt up or down manually, using the manual release valve.

### **⚠ WARNING**

**Keep everyone clear of a tilted outboard when backing out the manual release screw. The outboard could drop suddenly and forcibly. Be sure to tighten the manual release screw after manually repositioning the outboard. Tightening the screw also reactivates the outboard's impact protection and reverse thrust capability.**

- 1) Turn the manual release screw counter-clockwise, slowly (about 3 1/2 turns), until it **lightly** contacts its retaining ring.
- 2) Reposition the outboard.
- 3) Tighten the manual release valve to hold the outboard in its new position.

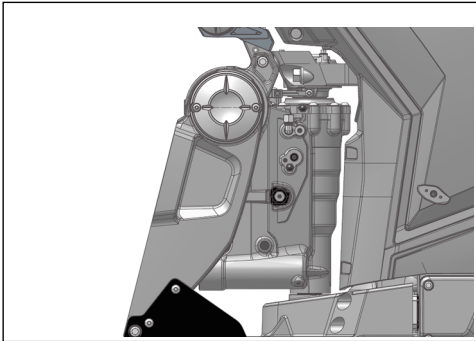

Manual Release Screw

009059

## Impact Damage Protection

### **⚠ WARNING**

**Any malfunction of the power trim and tilt unit could result in loss of shock absorber protection if an underwater obstruction is hit. Malfunction can also result in loss of reverse thrust capability. Correct fluid level must be maintained to ensure operation of the impact protection on this unit.**

Your outboard has a shock absorption system designed to help withstand damage from im-

part with underwater objects at low to moderate speeds.

Such impacts can result in serious damage to your outboard or boat. Occupants can also be ejected or injured by falling against portions of the boat as a result of rapid deceleration following impacts.

When boating in unfamiliar, shallow, or debris-laden waters, seek information on safe boating areas and navigation hazards from a reliable local source. Reduce your speed and keep a sharp lookout!

**IMPORTANT:** Impact damage is NOT covered by the outboard warranty.

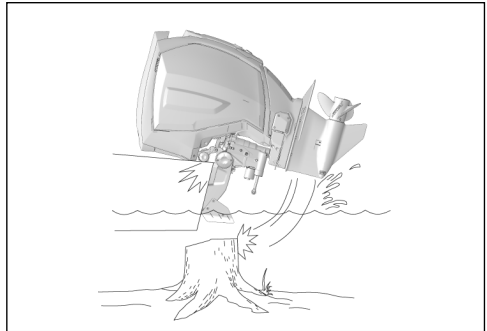

009060

### **NOTICE**

**The outboard's shock absorption system does not work while operating in reverse. If you back into an object, either in the water or while trailering, your boat and outboard can be seriously damaged.**

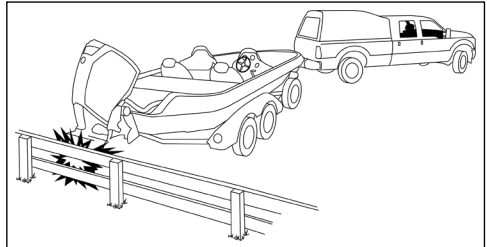

009061

If you hit any object:

- STOP immediately and examine the outboard for loosening of attaching hardware.

- INSPECT for damage to swivel and stern brackets, and steering components.
- EXAMINE the boat for structural damage.
- TIGHTEN any loosened hardware.

If the collision occurred in the water, proceed slowly to harbor. Before boating again, have your Dealer thoroughly inspect all components.

If your engine will not trim to the fully DOWN position, it may have impacted an underwater object. See the **Service Note** on page 51.

**⚠ WARNING**

**Failure to inspect for damage after an accident or striking an object could result in sudden, unexpected component failure, loss of boat control, and personal injury. Unrepaired damage could reduce your boat and outboard's ability to resist future impacts.**

## Dynamic Power Steering (DPS)

Your outboard may be equipped with Dynamic Power Steering (DPS). DPS offers three power steering assist levels.

### Power Steering Assist Levels

All power steering assist levels provide the same rate of assist at engine speeds below 4500 RPM.

As engine speed increases above 4500 RPM, assist levels progressively decrease.

The factory default assist level is "Minimum". Use the *Evinrude ICON-Touch* or *ICON CS*

digital display to change the power steering assist level to "Medium" or "Maximum".

**⚠ WARNING**

**Selection of power steering assist level is a matter of operator preference.**

**Be aware that changing the power steering assist level can affect boat handling.**

**After changing the level of power steering assist, operate the boat with care to become familiar with any changes in boat handling characteristics.**

If your boat is not equipped with an *ICON* digital display, your Dealer must use *Evinrude Diagnostic* software to change the power steering assist level.

## iDock Maneuvering System

For boats equipped with the *Evinrude iDock* maneuvering system for two outboards, refer to the "*iDock User's Guide*" for complete information about using the *iDock* system.

## Engine Monitoring

**IMPORTANT:** Your outboard must be equipped with an engine monitoring system such as *Evinrude ICON Touch*, *ICON*, or other *NMEA 2000* compliant CANbus instruments.

An analog *SystemCheck* gauge, or equivalent may be used. Analog gauges REQUIRE the installation of a digital to analog converter.

The engine monitoring system provides engine operating information and alerts you of abnormal conditions that could damage your outboard. The monitoring system consists of a dash-mounted display or gauge, sensors on the engine and oil tank, and related wiring. A warning horn is an OPTIONAL accessory and SHOULD be ordered separately.

### Displays and Gauges

Gauges and displays are available in several styles, such as a *Evinrude ICON Touch*, *ICON Pro* with digital LCD display or a basic *SystemCheck* gauge.

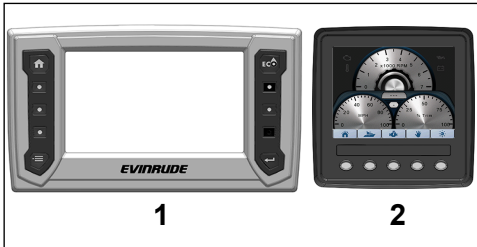

Displays and Gauges (Typical) 009062  
1. *Evinrude ICON Touch 7.0* 010671  
2. *ICON 3.5C*

Refer to the display or gauge user's guide for operation, warnings, and monitoring instructions.

### System Self-Test

During engine start-up, pause with the key switch in the ON position. Digital displays and gauges will self test as follows:

***Evinrude ICON Touch*** — The digital touch screen displays a “booting” screen, followed

by the *Evinrude* logo and then the default home page.

***ICON*** — The *ICON* gauge sounds a beep. The tachometer and speedometer LCD screens display SELF TEST MODE IN OPERATION. When the self test is complete, the gauges will beep a final time and then display SELF TEST COMPLETE!

***SystemCheck*** — The *SystemCheck* gauge indicator lights turn on simultaneously, then off in sequence. If equipped with an OPTIONAL warning horn, the *SystemCheck* monitor sounds a beep.

### Engine Monitor Warnings

Engine monitor system warnings activate the the appropriate warning indicator for a minimum of 30 seconds, or until the alarm is acknowledged. If the abnormal operating condition continues, the warning indicator remains ON until the key is turned OFF or the failure is corrected.

The warning will reoccur at the next startup if the problem is not corrected.

### Speed Adjusting Failsafe Electronics (S.A.F.E.)

If the *EMM* senses a problem could cause permanent engine damage, it will limit engine speed to 1200 RPM. This additional protection feature is referred to as *S.A.F.E.* (Speed Adjusting Failsafe Electronics).

If the engine was running faster than 1200 RPM when the *S.A.F.E.* mode activated, it will shake noticeably.

Under certain operating conditions the *EMM* will shut OFF the engine.

**⚠ WARNING**

In the *S.A.F.E.* mode, engine speed is limited. Under certain conditions, the engine's limited speed may reduce maneuverability of your boat. If the *S.A.F.E.* mode is activated and you are unable to correct the problem, seek assistance and/or return to safe harbor. Serious engine damage and/or reduced maneuverability may be imminent.

**Under certain operating conditions the EMM will shut OFF the engine.**

The following warnings may appear on the engine monitor gauge:

**LOW OIL**

The LOW OIL warning indicates the oil in the oil tank is at the reserve level (about 1/4 full). The *EMM* will initiate the following failsafe actions:

- activate the display warning or LOW OIL indicator

Fill the oil tank with recommended outboard oil soon to avoid emptying the tank. See **Fill-ing the On-Engine Oil Tank** on page 15.

There is approximately one-hour of wide-open-throttle running time when the reserve oil level is reached.

**NO OIL**

The NO OIL warning indicates there is an oil delivery problem. The *EMM* will initiate the following failsafe actions:

- activate the display warning or NO OIL indicator
- activate *S.A.F.E.* mode

If the oil tank is empty, add the recommended oil.

If the oil tank is not empty, seek assistance and/or return to safe harbor.

Your outboard is designed to run in *S.A.F.E.* mode at reduced speed for up to 5 hours in the event you run out of oil. Refill the oil tank.

After 5 hours, the *EMM* will activate SHUT DOWN mode and set Fault Code 33; Critical NO OIL.

**IMPORTANT:** If the outboard enters SHUT DOWN mode, refill the oil tank. Then prime oil system. See **Priming the Oil System** on page 15.

**TEMP or HOT**

The TEMP warning indicates the engine is overheating. Depending on the severity of the overheating, the *EMM* may initiate one or more of the following failsafe actions:

- activate the TEMP warning or HOT indicator
- activate *S.A.F.E.* mode
- activate shut down

If the TEMP warning activates, see **Trouble-shooting** on page 49.

**CHECK ENGINE**

The CHECK ENGINE warning indicates an abnormal engine condition. Depending on the severity of the condition, the *EMM* may initiate any of the following failsafe actions:

- activate the display warning or CHECK ENGINE indicator
- activate *S.A.F.E.* mode
- activate shut down

If the CHECK ENGINE warning activates, see **Troubleshooting** on page 49.

**⚠ WARNING**

**If the outboard shuts OFF and the "CHECK ENGINE" indicator is flashing, the outboard cannot be restarted. A hazardous fuel condition may exist.**

**Seek assistance to return to port. Seek service from an authorized Evinrude dealer, repair shop, or person of your own choosing for maintenance, repair, or replacement.**

## Special Operating Conditions

### Cold and Freezing Weather

#### NOTICE

**When operating in conditions under 32°F (0°C), Evinrude XD100 oil, must be used.**

During operation in freezing weather, keep the gearcase submerged at all times.

Upon removing your outboard from the water, leave it in a vertical position until its cooling system is drained. Store the outboard vertically.

#### NOTICE

**Water remaining in the gearcase, cooling system or other components can freeze, causing serious engine damage.**

### Multiple Outboard Operation

When in reverse above slow speed, be sure all outboards are running, even if one is in NEUTRAL.

If it is necessary to return to harbor with one outboard not running, tilt the inoperative outboard high enough to keep its propeller out of the water.

### High Altitude

Your outboard's *EMM* will automatically compensate for changes in altitude. However, if you boat above 3000 ft. (900 m), you will experience some loss of power due to reduced air density.

If your engine drops below the recommended RPM operating range at full throttle, have your Dealer select a lower pitch propeller.

If you return to sea level, have your Dealer install the original propeller and verify correct RPM operating range.

### Salt Water

Anode protection for the outboard has been provided for use in salt or brackish water.

Upon removal from salt water, leave outboard in a vertical position until its cooling system has drained. During long periods of mooring, tilt the gearcase out of the water, except in freezing temperatures. Flush the outboard, if desired. Refer to **Flushing** on page 43.

### Shallow Water

Gearcase damage can occur if the gearcase is allowed to drag on the waterway bottom. Use caution when operating in shallow water.

**IMPORTANT:** Impact damage is NOT covered by the outboard warranty.

### Under Tow

Should you require a tow from another boat:

- Shift your engine to NEUTRAL;
- Tilt its gearcase out of the water;
- Off-load all persons into another boat; and
- Keep speed slower than planing speed.

### Weedy Water

Weeds block water intakes and may cause your outboard to overheat. Weeds on the propeller create vibration and reduce boat speed.

When operating in weedy water, run at slow speeds and in REVERSE frequently to clear weeds from the propeller and water intakes. Check the water pressure often.

If REVERSE operation does not clear away weeds, SHUT OFF the engine. Remove weeds from propeller area and water intakes before operating at higher speed.



# Transporting the Outboard

## Trailerling

### WARNING

Keep everyone clear of stern area when raising or lowering the outboard. Personal injury or death can result from contact with moving parts of the outboard.

### NOTICE

When trailerling your outboard, **DO NOT** cover the engine with canvas—it will dull the finish of the outboard's engine covers.

### Trailerling Lever

The outboard is designed to be trailerled in a tilted position using the trailerling lever, or in a vertical position.

**To engage lever** — Tilt the outboard fully using the trailerling tilt switch on the starboard engine cover, or the trim/tilt switch on the remote control.

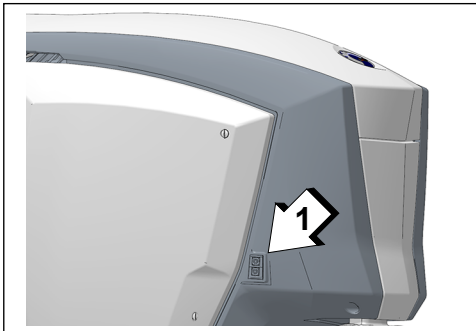

1. Trailerling tilt switch

009041A

Push the trailerling lever up. A detent will hold the lever in position.

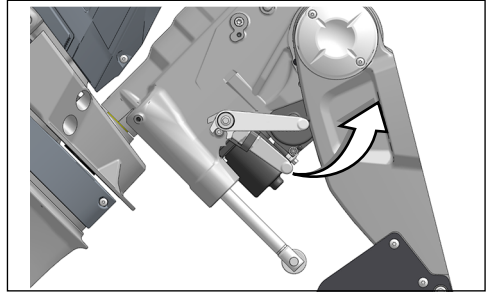

009066

Lower the outboard until the trailerling lever locks into place in the stern brackets.

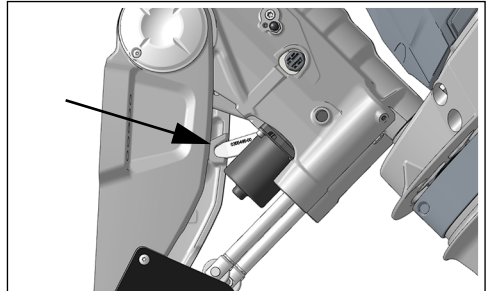

009083

Use the trailerling lever if you intend to leave the outboard tilted for a period of time.

**To disengage lever** — Tilt the outboard fully. Return the trailerling lever to its stowed position. Lower the outboard to its vertical position.

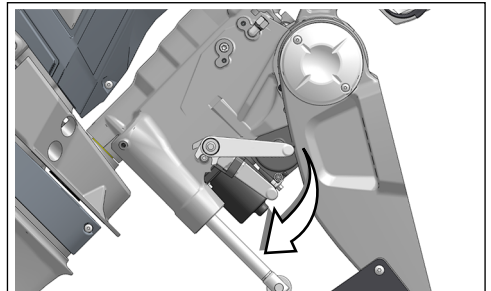

009068

## Transporting / Storage

If the outboard is removed from the boat for transportation or storage, you **MUST**:

- Seal the oil and fuel lines on the boat and on the outboard to prevent leaks and prevent contaminants from entering the oil or fuel system.
- Install shipping brackets to prevent the outboard from turning.
- Cap steering fittings on the outboard and hydraulic hoses to prevent leaks and prevent contaminants from entering the hydraulic system.

### **WARNING**

**A small amount of fuel may be released when the fuel line is disconnected.**

**Gasoline is extremely flammable and highly explosive under certain conditions. Do not allow disconnected fuel hoses to leak fuel.**

**Use caution when working on the fuel system. Wear safety glasses and work in a well ventilated area. Extinguish all smoking materials and make certain no open flames or ignition sources exist.**

**Always wipe off any fuel spillage.**

### **ENVIRONMENTAL NOTE**

Dispose of oil or fuel contaminated towels in an environmentally responsible manner, or according to local regulations.

The engine is shipped from the factory without color engine cover panels. A shipping cover is used to protect the engine during shipment.

### **NOTICE**

**Do not install the shipping cover after the engine cover panels are installed, the decals or covers could be scratched.**

# Pre-Ride Inspection

## WARNING

Always perform a pre-ride inspection before operating the boat. Check the proper operation of critical controls, safety features and mechanical components. Correct any problems BEFORE leaving the dock. Make sure all safety equipment required by local law is onboard.

## WARNING

The engine(s) should be OFF and the tether cord must always be removed from the engine cut-off switch before verifying any of the following. Only start the engine(s) after all items have been checked and operate properly.

| ITEM                               | OPERATION   | ✓ |
|------------------------------------|---|---|
| Hull                               | Inspect.  |   |
| Propeller                          | Inspect condition of propeller. Repair or replace damaged propeller.  |   |
| Cooling system                     | Inspect water intake screens.   |   |
| Safety equipment                   | Ensure safety equipment is onboard.   |   |
| Oil level                          | Check. Refill as needed.  |   |
| Bilge                              | Drain. Ensure drain plug(s) are securely installed.   |   |
| Battery                            | Check battery connections are clean, tight, and insulated. Ensure battery/battery box are secure.   |   |
| Fuel level                         | Check. Refill as needed.  |   |
| Navigation lights                  | Check operation.  |   |
| Steering system                    | Check operation.  |   |
| Boat systems (horn, pumps, radio)  | Check operation.  |   |
| Engine cut-off switch/ tether cord | Inspect condition of tether cord. Attach to key switch or engine cut-off switch (depending on application). Test operation. Reattach tether cord to switch. |   |
| Operator's Guide                   | Confirm this Operator's Guide is onboard and readily accessible.  |   |
| Key / Engine Start switches        | Test operation.   |   |
| Displays & Gauges                  | Self-test, check operation  |   |
| Shift and Throttle                 | Check operation.  |   |
| Trim System                        | Check operation.  |   |
| Cooling system                     | Confirm operation (water pump indicator).   |   |

## Aquatic Invasive Species (AIS)

Aquatic Invasive Species (AIS) are non-native plant or animal species that threaten the diversity or abundance of the native species. They also threaten the natural ecology of the body of water they infest. AIS almost always have a negative impact on the waterway, its native species, and recreational or commercial activities on the waterway.

Common examples of AIS are; Eurasian watermilfoil, hydrilla, sea lampreys, zebra mussels, Asian carp, and gobies. Many other examples of AIS exist throughout the world's waterways.

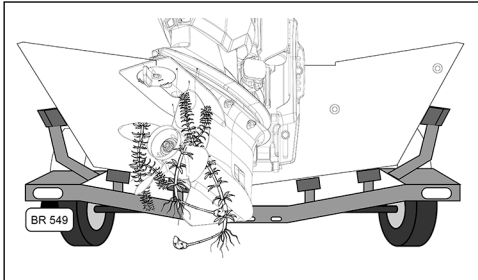

AIS on Outboard

010615

A typical factor in AIS infestations is that the non-native species are introduced by human activity. Some AIS are introduced by commercial operations; however AIS can be introduced through recreational boating activities. The transportation of recreational boats and water sports equipment between waterways can be a major factor in the spread of AIS.

Small pieces of plants or animals hanging from a propeller, trailer or wakeboard can transfer enough biological material to establish an AIS in a new waterway. The early reproductive stages of many AIS are microscopic; small amounts of water in a bilge, live well, cooler or trapped in a compartment can contain enough organisms to establish an infestation.

As responsible boat owners we **MUST** do our part to prevent the spread of these aquatic hitchhikers. Check your boat each time you leave the water! In many cases it is required by law, be sure to check the local regulations for the waterways where you boat.

### **Clean, Drain & Dry – Everything, Every Time!**

Before you leave a waterway, follow the procedure below to help prevent the spread of AIS.

#### **Clean**

Inspect and remove any visible mud, aquatic plants, fish or animals from the boat, trailer and any water sports equipment before transporting your equipment.

#### **Drain**

Remove all water from the boat, including ballast, bilge, livewell, engine and gearcase. Dispose of unwanted live bait in the trash.

#### **Dry**

Allow the boat to completely dry before visiting any other bodies of water.

## AIS Inspection Checklist

Use the following checklist as a guide when inspecting for AIS.

| Inspection Items |    |   | ✓ |
|------------------|----|---|---|
| Boat             | 1  | Inspect hull.   |   |
|                  | 2  | Inspect floor.  |   |
|                  | 3  | Inspect live well.                                      |   |
|                  | 4  | Inspect transom well.                                   |   |
|                  |    | Inspect water inlet & outlet fittings.                  |   |
|                  |    | Inspect anchors and lines.                              |   |
|                  |    | Inspect boarding ladder.                                |   |
|                  |    | Inspect transducers or other attachments to the hull.   |   |
| Accessories      |    | Inspect fishing tackle and fishing lines.               |   |
|                  |    | Inspect bait buckets.                                   |   |
|                  |    | Inspect landing nets.                                   |   |
|                  |    | Inspect water sports equipment (skis, wakeboards etc.). |   |
|                  |    | Inspect tow ropes.                                      |   |
| Outboard(s)      | 5  | Inspect water intake screens.                           |   |
|                  | 6  | Inspect gearcase.                                       |   |
|                  | 7  | Inspect propeller.                                      |   |
| Trailer          | 8  | Inspect bunks and/or rollers.                           |   |
|                  | 9  | Inspect fenders & frame.                                |   |
|                  | 10 | Inspect tires & wheels (including spare tire)           |   |
|                  |    | Inspect license plate & brackets.                       |   |
|                  |    | Inspect lights and wiring.                              |   |

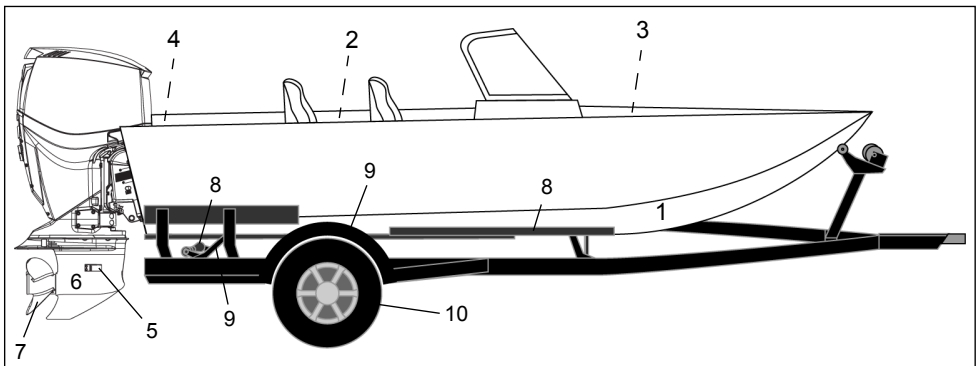

***EVINRUDE***®  
***E-TEC***®



---

# Maintenance

# Engine Emissions Installation Information

A repair shop or person of the owner's choosing may maintain, replace, or repair emission control devices and systems. These instructions do not require components or service by BRP or authorized *Evinrude* dealers. Although an authorized *Evinrude* dealer has the in-depth technical knowledge and tools to service *Evinrude* outboard engines, the emission-related warranty is not conditioned on the use of an authorized *Evinrude* dealer or any other establishment with which BRP has a commercial relationship.

For emission-related warranty claims, BRP is limiting the diagnosis and repair of emission-related parts to authorized *Evinrude* dealers. For more information, please refer to the US EPA EMISSION-RELATED WARRANTY contained herein. Proper maintenance is the owner's responsibility. A warranty claim may be denied if, among other things, the owner or operator caused the problem through improper maintenance or use.

You must follow the instructions for fuel requirements in the **FUEL REQUIREMENTS** section of this manual. Even if gasoline containing greater than ten volume percent ethanol is readily available, the US EPA has issued a prohibition against the use of gasoline containing greater than 10 vol% ethanol that applies to this engine. The use of gasoline containing greater than 10 vol% ethanol with this engine may harm the emission control system.

### ***Manufacturer's Responsibility***

Beginning with 1999 model year outboards, manufacturers of marine engines must determine the exhaust emission levels for each engine horsepower family and certify these outboards with the United States of America Environmental Protection Agency (EPA). An emissions control information label, showing emission levels and engine specifications, must be placed on each outboard at the time of manufacture.

### ***Dealer's Responsibility***

When performing service on all 1999 and more recent *Evinrude* outboards that carry an emissions control information label, adjustments must be kept within published factory specifications.

Replacement or repair of any emission related component must be executed in a manner that maintains emission levels within the prescribed certification standards.

Dealers are not to modify the outboard in any manner that would alter the horsepower or allow emission levels to exceed their predetermined factory specifications.

Exceptions include manufacturer's prescribed changes, such as altitude adjustments, for example.

### ***Owner Responsibility***

The owner/operator is required to have engine maintenance performed to maintain emission levels within prescribed certification standards.

The owner/operator is not to, and should not allow anyone to, modify the engine in any manner that would alter the horsepower or allow emissions levels to exceed their predetermined factory specifications.



Tampering with the fuel system to change horsepower or modify emission levels beyond factory settings or specifications will void the product warranty.

### ***EPA Emission Regulations***

All new 1999 and more recent *Evinrude* outboards manufactured by BRP are certified to the EPA as conforming to the requirements of the regulations for the control of air pollution from new watercraft marine spark ignition engines. This certification is contingent on certain adjustments being set to factory standards. For this reason, the factory procedure for servicing the product must be strictly followed and, whenever practicable, returned to the original intent of the design. The responsibilities listed above are general and in no way a complete listing of the rules and regulations pertaining to the EPA requirements on exhaust emissions for marine products. For more detailed information on this subject, you may contact the following locations:

U. S. Environmental Protection Agency  
Office of Transportation and Air Quality  
Certification Division  
Gasoline Engine Compliance Center  
2000 Traverwood Drive  
Ann Arbor, MI 48105

### **EPA Internet Web Site:**

[www.epa.gov/otaq](http://www.epa.gov/otaq)

## Maintenance & Inspection Schedule

Routine inspection and maintenance is necessary to ensure outboard life. The following chart provides guidelines for inspection and maintenance. The 500 hour/5 year service should be performed by an authorized Dealer, repair shop, or person of your own choosing.

**IMPORTANT:** Adjust the maintenance schedule for operating and environmental conditions. Outboards used in rental, commercial, or other high hour applications require more frequent inspections and maintenance.

| Description                                | Dealer Maintenance Every 500 Hours or 5 Years <sup>(1)</sup>    |   |     |
|--|---|---|-----|
|  | Customer Inspections Every 100 Hours or Annually <sup>(1)</sup> |   |     |
|  | Engine Care Product   |   |     |
|  | Action  |   |     |
| Anodes (corrosion protection)              | Check condition <sup>(1), (2)</sup>                             |   | ✓ ✓ |
| Back pressure probe                        | Replace   |   | ✓   |
| Covers                                     | Wash and wax, repair scratches                                  |   | ✓   |
| Fluid levels (steering and trim)           | Inspect level   |   | ✓   |
| Fuel filters                               | Replace   |   | ✓   |
| Gearcase lubricant                         | Inspect level, See “Gearcase Lubricant Level” on page 45.       |   | ✓   |
| Gearcase lubricant                         | Replace   | A | ✓   |
| Grease fittings                            | Lubricate   | B | ✓   |
| Oil Filter (optional remote oil tank only) | Replace   |   | ✓   |
| Propeller shaft splines                    | Inspect and lubricate   | B | ✓   |
| Service codes                              | Access EMM, check for and resolve any codes                     |   | ✓   |
| Spark plugs                                | Replace <sup>(3)</sup>  |   | ✓   |
| Thermostat                                 | Inspect <sup>(3)</sup>  |   | ✓   |
| Water pump                                 | Replace   |   | ✓   |

- (1) Whichever comes first. Certain conditions may require more frequent inspection and maintenance.
- (2) Annually in salt water applications – Refer to **Service** on page 43.
- (3) Emission-related component. Refer to **Owner Responsibility** on page 40, **Product Warranty Information** on page 63 and, if applicable, **California Emission Control Warranty Statement** on page 72.

### Engine Care Products

The engine care products listed in the table below are referenced in this guide, and are recommended for use with *Evinrude E-TEC G2* outboards.

|           | Product                                   | Use                                    |
|-----------|---|--|
| <b>A.</b> | <i>HPF Pro</i> Gearcase Lubricant         | Gearcase                               |
| <b>B.</b> | <i>Triple-Guard</i> Grease                | Grease fittings, propeller shaft       |
| –         | <i>Power Trim/Tilt Fluid</i> , P/N 767969 | Power Trim and Tilt System             |
| –         | <i>SeaStar</i> Steering Fluid, P/N 770891 | Hydraulic Steering System              |
| –         | <i>Evinrude 2+4 Fuel Conditioner</i>      | Protect fuel system and condition fuel |
| –         | Anti-Corrosion Spray                      | Protect metal parts from corrosion     |

# Service

## Anodes

Your outboard is equipped with one or more sacrificial anodes that protect it from galvanic corrosion. Disintegration of the anode is normal and indicates it is working. Check each anode periodically. Replace anodes smaller than 2/3 their original size. See your Dealer for replacements.

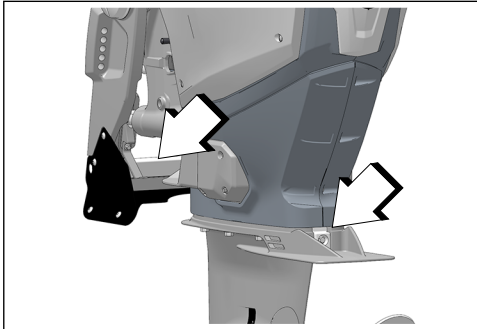

Anti-corrosion anodes

009069

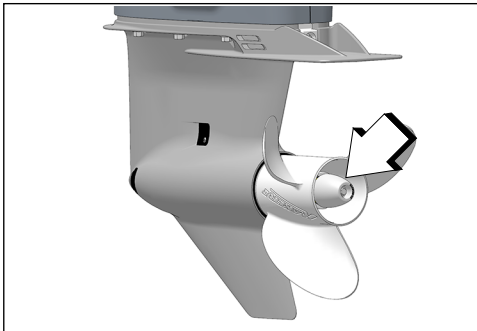

Anti-corrosion anode

009070

Galvanic corrosion destroys underwater metal parts and can occur in fresh or salt water; however, salt, brackish, and polluted waters will accelerate corrosion.

Metal-based anti-fouling paint on the boat or outboard and the use of improperly installed

shore power in the area of your moored boat will also accelerate corrosion.

### NOTICE

**NEVER** paint the anode, its fasteners, or its mounting surface. Painting will reduce its corrosion protection.

## Flushing

### NOTICE

**IMPORTANT:** Trim the outboard to the fully down position to flush the engine.

Flushing the engine with the outboard tilted can allow water to enter the cylinders, resulting in engine damage.

When flushing is complete, store the outboard in the recommended down position.

If the outboard must be stored in a tilted position, make **SURE** the cooling system is drained completely **BEFORE** tilting.

Never place the gearcase higher than the powerhead. Any water remaining in the exhaust passages can run into the cylinders and cause serious damage.

Flush the outboard with fresh water following use in brackish, or polluted water to minimize the accumulation of scale and silt deposits in cooling system passages. The outboard can be flushed on the trailer or at dockside. Trim the outboard to the fully down position in a well ventilated area.

It is **not** necessary to run the engine when flushing. IF you decide to run the engine observe the following additional steps:

- Remove the propeller.
- RUN AT IDLE SPEED only.
- Reinstall the propeller. See **Propeller** on page 58.

## Maintenance

### Accessory Flushing Kit

- 1) Place the outboard in an area with good drainage.
- 2) Turn the rigging center cover 90° counter-clockwise and gently squeeze to remove the cover. Access the flushing hose connector and remove the protective cover from the connector.
- 3) Connect a garden hose to the flushing adapter and connect it to the flushing hose connector.

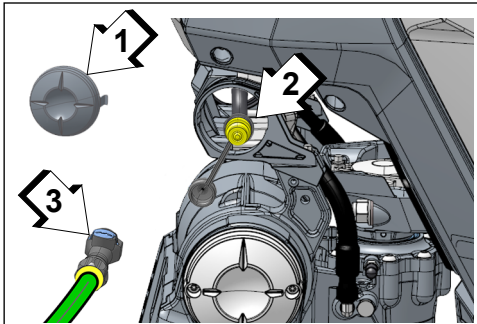

1. Rigging center cover
2. Flushing hose connector
3. Flushing adapter

009896

- 4) Make sure the outboard is tilted fully down. Turn on the water. Keep the water pressure between 20 and 40 psi (140 to 300kPa).
- 5) After flushing, leave the outboard in the vertical position long enough to completely drain the powerhead.
- 6) While the outboard is draining:
  - Disconnect the flushing adapter from the connector and install the protective cap on the flushing hose connector
  - Replace the rigging center cover: Align the tabs on the cover, with the slot on the rigging center.

Turn the cover 90° clockwise to lock in place.

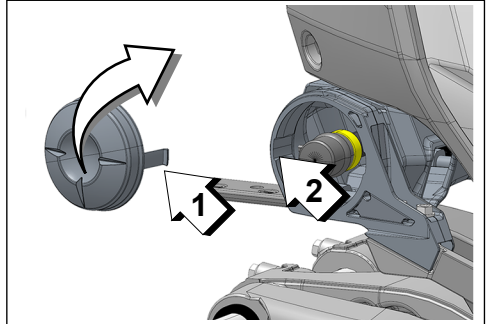

1. Tab
2. Slot

009905

### Lower Engine Cover Flushing Port

- 1) Place the outboard in an area with good drainage.
- 2) Connect a garden hose to the flushing port.

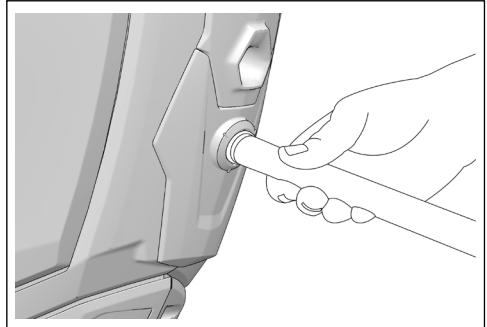

009071

- 3) Turn on the water. Keep the water pressure between 20 and 40 psi (140 to 300kPa).
- 4) After flushing, leave the outboard in the vertical position long enough to completely drain the powerhead.

## Fuses

A blown fuse could prevent the engine from starting.

Repeated fuse failures indicate a potentially serious problem. Do not replace it with higher rated fuse.

### Fuse Replacement

#### NOTICE

Use only fuses of the same rating.

Your outboard uses the following Mini-Fuses. See your Dealer for replacement fuses.

| Fuses       |                      |
|-------------|----------------------|
| Fuse Rating | Replacement Fuse P/N |
| 3           | 3011805              |
| 5           | 514764               |
| 10          | 514766               |
| 30          | 3011729              |

Remove port engine cover. Remove cover from fuse box. Replace failed fuse.

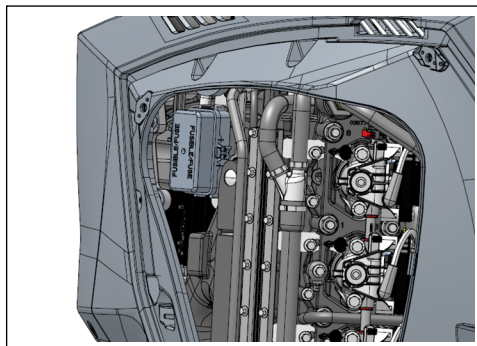

Fuse Box

009074

#### NOTICE

Failure to install cover securely may cause electrical problems.

## Gearcase Lubricant Level

Remove starboard engine cover. Inspect the lubricant level in the oil reservoir.

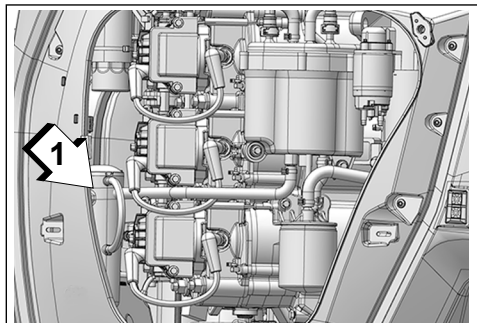

1. Lubricant reservoir

009140

Lubricant level should be between the marks as shown.

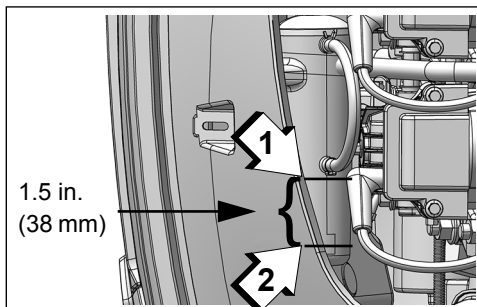

Lubricant Level

009141

1. Maximum
2. Minimum

## Hull Finish

The condition of your boat's bottom affects performance. Marine growth or bottom painting may reduce speed and fuel efficiency.

For maximum performance, keep the boat's running surface clean by rinsing it with fresh water and wiping it dry. Apply *Evinrude* anti-corrosion spray to any surface subject to corrosion, but avoid the anti-corrosion anode(s).

## Maintenance

### Outboard External Finish

Periodically, wash the entire boat and outboard with soapy water and apply a coat of automotive wax. Leave the engine covers in place when washing the outboard.

#### NOTICE

If needed, use *Evinrude* Marine Cleaner to clean plastic covers or panels. Do NOT use solvents such as acetone.

### Scratch Repair

Surface scratches on the engine covers can be repaired or painted.

**IMPORTANT:** Your Dealer has the professional materials or matching paint colors to properly repair scratches. See your Dealer to repair any deep scratches or gouges.

### Spark Plugs

#### ⚠ CAUTION

The ignition system presents a serious shock hazard. Use caution to avoid injury from shock or injury resulting from your reaction to shock. Do not handle primary or secondary ignition components while the engine is cranking or running.

Incorrect spark plug maintenance can lead to engine damage.

### Marine Engine Duty Cycles

The International Council of Marine Industry Associations (ICOMIA) Standard No. 36-88 specifies a marine engine duty cycle based on documented studies. A duty cycle is a profile of engine running and usage. This duty cycle is used to determine average spark plug longevity and maintenance requirements.

#### ICOMIA Marine Engine Duty Cycle

| Engine Speed as Percentage of Rated Speed (RPM) | Time at Specified RPM (Percentage of total engine running time) |
|---|---|
| IDLE  | 40%   |
| 40%   | 25%   |
| 60%   | 15%   |
| 80%   | 14%   |
| 100%  | 6%  |

#### NOTICE

Some running profiles and conditions can lead to spark plug wear sooner than expected. Depending on your specific usage, the spark plug maintenance schedule may require adjustment.

### Submerged Outboard

If your outboard has been under water, **have it serviced immediately upon recovery.**

After submersion, all boat and engine electrical, fuel, and oiling systems must be inspected for signs of water intrusion. See the **Service Note** on page 51.

# Storage

## WARNING

**DO NOT run the engine indoors or without adequate ventilation or permit exhaust fumes to accumulate in confined areas. Engine exhaust contains carbon monoxide which, if inhaled, can cause serious brain damage or death.**

Protect against natural environmental conditions that can be damaging to an outboard. Your warranty does not cover engine failure caused by these conditions.

## NOTICE

**Temperature and humidity changes during storage period can cause corrosion of internal engine components.**

**Stabilize the fuel supply.** Fuel remaining in your fuel tank can oxidize, resulting in loss of octane and fuel system deposits.

Use *Evinrude 2+4 Fuel Conditioner* to prevent gum and varnish deposits from forming in fuel system components.

## WARNING

**Prevent injury from moving engine components. Before starting the outboard:**

- **Shift it to NEUTRAL.**
- **Keep hands, clothes, and hair clear of powerhead.**

**If on a trailer, remove the propeller.**

If the outboard is removed from the boat for transportation or storage, you **MUST**:

- Seal the oil and fuel lines on the boat and on the outboard to prevent leaks and prevent contaminants from entering the oil or fuel system.
- Install shipping brackets to prevent the outboard from turning.
- Cap steering fittings on the outboard and hydraulic hoses to prevent leaks and prevent contaminants from entering the hydraulic system.

## Short-Term Storage

If you must tilt the outboard to remove it from the water, lower it and allow the cooling system to drain completely as soon as you clear the launch area. Between uses, store your outboard in a vertical position.

## Long-Term Storage (Winterization)

### WARNING

**If winterizing on a trailer, the propeller must be removed before performing procedure. Failure to remove propeller can cause personal injury or death.**

Winterization prepares your outboard for long-term off-season storage. During winterization, the engine is “fogged” with extra oil to coat internal engine components.

Winterization requires a specific process of steps.

**Note:** The *Evinrude ICON* touch digital display provides a one-touch winterization. See the *ICON Touch User’s Guide*.

Closely follow the applicable winterization procedure for your outboard:

- Remote control
- Remote control with foot throttle

You can confirm your outboard enters winterization mode when the engine runs at fast idle and:

- The *ICON* gauge displays a winterization message (if equipped).
- The *SystemCheck* gauge lights flash (if equipped).

### Preparation

Your outboard can be winterized in the water. **If winterizing in water**, make sure the water intake screens are completely submerged.

- 1) Stabilize the engine’s fuel supply. Add 2+4 Fuel Conditioner following instructions on container. Fill fuel tank.
- 2) **If winterizing on a trailer**, remove the propeller. Attach a garden hose to flushing

## Maintenance

port and turn on the water. Refer to **Flushing** on page 43.

- 3) Turn the key switch to the OFF position.
- 4) Move the lever(s) to the FORWARD wide open throttle position.

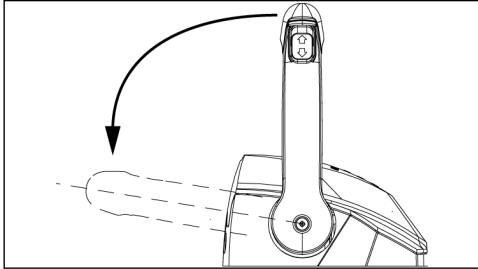

Binnacle Mount Control (shown)

009076

- 5) Turn the key switch to ON and wait a minimum of three seconds.
- 6) Attempt to start the outboard three times within three seconds (the starter will not engage or crank the outboard).
- 7) Move the lever to NEUTRAL and start the outboard(s).
- 8) Run the outboards at idle for a minimum of three seconds.
- 9) With the outboard(s) running, attempt to start the outboard three times within three seconds (the starter will not engage or crank the outboard).
- 10) The remote control will send the winterization message to each outboard. Only running outboard(s) will be winterized.
- 11) The outboard(s) will automatically shut off when the process is complete.

During the winterization process, the remote control will ignore all throttle, gear, and switch operations. The control WILL acknowledge Key OFF or Emergency Stop commands.

Trim the outboard to the fully down position to store. If the outboard must be stored in a tilted position, make SURE the cooling system is drained completely BEFORE tilting.

### Pre-Season Check

Remove your outboard from storage and prepare it for a season of reliable service by performing a general check and a few preventive maintenance procedures.

Check for loosened or removed hardware. Replace damaged or missing parts with *Evinrude Genuine Parts* or equivalent. Check the gearcase for leakage. If leakage is evident, the gearcase seals should be replaced. See the **Service Note** on page 51.

**IMPORTANT:** Gearcase lubricant is **thick and clear**. Do not confuse this with engine oil, which may normally appear on the skeg after performing the long-term storage procedure.

**Anti-corrosion anodes** — Check condition. See **Anodes** on page 43.

**Battery** — Charge. See **Battery** on page 56.

### ⚠ WARNING

**Do not use a booster battery and jumper cables to start the outboard. Gasoline fumes can cause explosion and fire, resulting in property damage, personal injury or death.**

Review your outboard's warning system self-test routine. During start-up, make sure the warning system self-tests properly.

### NOTICE

**Do not run your outboard—even for a brief start-up—without supplying water to it.**

Following **Engine Starting** on page 21, start the outboard. If the outboard was winterized, it will emit a puff of smoke on the first start of the season.

Let engine idle while you:

Observe running quality. If poor, refer to **Troubleshooting** on page 49.

Confirm water pump operation. Water must flow from the water pump indicator in a steady stream. If it does not, shut off the outboard and investigate.

Stop the outboard and check the fuel system for leaks.

### ⚠ WARNING

**Failure to check for fuel leakage could allow a leak to go undetected, resulting in fire or explosion.**



# Troubleshooting

| SYMPTOM                                      | POSSIBLE CAUSE   |
|--|--|
| Starter motor will not operate               | <ul style="list-style-type: none"> <li>• Shift handle not in NEUTRAL.</li> <li>• Fuse blown.</li> <li>• Battery switch is in OFF position.</li> <li>• Battery is dead.</li> <li>• Flashing “NEUTRAL” LED indicator on remote control, refer to Emergency Start Procedure on page 46</li> </ul>   |
| Engine will not start                        | <ul style="list-style-type: none"> <li>• Not following starting instructions. Refer to <b>Engine Starting / Stopping</b> on page 19.</li> <li>• Fuel system not primed after running out of fuel. Refer to <b>Operation</b> on page 19.</li> <li>• Fuel tank empty.</li> <li>• Fuel hose kinked.</li> <li>• Fuel system contaminated with water or dirt.</li> <li>• Fuel filter obstructed.</li> <li>• Spark plugs incorrect. Refer to <b>Service</b> on page 43.</li> <li>• Spark plugs improperly gapped, carboned, burned, or wet.</li> <li>• Flashing “Check Engine” or “Chk Eng” indicator, refer to <b>Engine Monitoring</b> on page 30.</li> </ul>  |
| Run Quality / Engine will not idle properly  | <ul style="list-style-type: none"> <li>• Debris on propeller.</li> <li>• Spark plugs damaged or incorrect. Refer to <b>Service</b> on page 43.</li> <li>• Fuel system contaminated with water or dirt.</li> </ul>  |
| Run Quality / Engine loses power             | <ul style="list-style-type: none"> <li>• S.A.F.E. protection mode activated. Review warning system information elsewhere in this chart. Also refer to <b>Engine Monitoring</b> on page 30.</li> <li>• Water intakes obstructed and cooling system not operating correctly. Refer to <b>Special Operating Conditions</b> on page 32.</li> <li>• Spark plugs damaged or incorrect. Refer to <b>Service</b> on page 43.</li> <li>• Fuel filter obstructed.</li> <li>• Fuel system contaminated with water or dirt.</li> <li>• Oiling system malfunction.</li> </ul>   |
| Engine runs, but makes little or no progress | <ul style="list-style-type: none"> <li>• Throttle needs to be reset, refer to <b>Operation</b> on page 19.</li> <li>• Propeller hub loose, slipping.</li> <li>• Propeller blades bent or missing.</li> <li>• Propeller fouled with debris.</li> </ul>  |
| Warning system activates the TEMP warning    | <p>S.A.F.E. protection mode activated with a <b>continuous</b> indicator — The <i>EMM</i> has identified an overheating condition.</p> <ul style="list-style-type: none"> <li>• Check the water pump indicator for a steady stream of water. Shut OFF the engine.</li> <li>• Clear the water intake screens of any debris. If the overheat condition still exists, the engine will operate in “get home” mode. Return to harbor immediately.</li> <li>• See <b>S.A.F.E. Reset</b> on page 50.</li> </ul> <p>S.A.F.E. protection mode activated with a <b>flashing</b> indicator — The <i>EMM</i> has identified a damaging overheating condition. The engine will not operate.</p> <ul style="list-style-type: none"> <li>• Allow the engine to cool for 20 minutes and return to harbor.</li> <li>• See <b>S.A.F.E. Reset</b> on page 50.</li> <li>• See the <b>Service Note</b> on page 51.</li> </ul> |

## Maintenance

| SYMPTOM   | POSSIBLE CAUSE  |
|---|---|
| Warning system activates the CHECK ENGINE warning | <p>S.A.F.E. protection mode activated with a <b>continuous</b> indicator — The <i>EMM</i> has identified a problem with the outboard.</p> <ul style="list-style-type: none"> <li>• Seek assistance and/or return to harbor.</li> <li>• See the <b>Service Note</b> on page 51.</li> </ul> <p>A <b>continuous</b> indicator without S.A.F.E. mode — The <i>EMM</i> has identified a problem that should be addressed as soon as practical to avoid operational difficulties. See the <b>Service Note</b> on page 51.</p> <p>Shut-down mode activated with a <b>flashing</b> indicator — The <i>EMM</i> has identified an abnormal operating condition related to the fuel system.</p> <ul style="list-style-type: none"> <li>• The engine will shut OFF and cannot be restarted.</li> <li>• Seek assistance and/or return to harbor.</li> <li>• See the <b>Service Note</b> on page 51.</li> </ul> <p>S.A.F.E. protection mode activated with a <b>continuous</b> indicator, outboard reduces speed to idle and shifts into NEUTRAL. Remote control LED indicators <b>flashing</b> rapidly. The digital display identifies codes 114 and 115, loss of network communication — The <i>EMM</i> has identified a problem with the digital networks.</p> <ul style="list-style-type: none"> <li>• Reset networks. Turn the key switch OFF. Then restart the engine(s).</li> <li>• Seek assistance and/or return to harbor.</li> <li>• See the <b>Service Note</b> on page 51.</li> </ul> |
| Steering is not smooth or feels “bumpy”           | <ul style="list-style-type: none"> <li>• Air in steering system</li> <li>• Hydraulic steering fluid low</li> <li>• Hydraulic hose kinked or restricted.</li> <li>• See the <b>Service Note</b> on page 51.</li> </ul>   |
| Steering effort is high                           | <ul style="list-style-type: none"> <li>• Air in steering system.</li> <li>• Hydraulic hose kinked or restricted.</li> <li>• See the <b>Service Note</b> on page 51.</li> </ul>  |

### S.A.F.E. Reset

In the event of an engine overheat, it may be possible to reset the S.A.F.E. system and restore normal operation:

- The engine must be shut off and the cooling temperature restored.

**IF** the S.A.F.E. mode activates and water pressure becomes intermittent or stops, reduce speed to idle and:

- 1) Shift to NEUTRAL.
- 2) SHUT OFF the engine.
- 3) Tilt the outboard up.
- 4) Clean the water intake screens of any blockage.
- 5) Clean the water pump indicator of any blockage.
- 6) Lower the outboard.
- 7) Restart the engine and run at idle.

**IF** cleaning the screens and indicator *does not* restore the water pump indicator’s steady discharge, the engine will operate only in S.A.F.E. mode. Return to harbor immediately. See the **Service Note** on page 51.

**IF** cleaning the screens and indicator *does* restore the water pump indicator’s steady discharge, you might have to run for two minutes in NEUTRAL to allow the engine to cool and the warning indicator to turn OFF.

**IMPORTANT:** If cooling is not restored, the *EMM* will identify a progressive overheating condition and shut off the engine. The “TEMP” warning will flash. The engine will not restart until the engine is allowed to cool.

*(Continued on next page)*

After any overheat causing engine shutdown, The following items should be inspected:

- Inspection of the water pump for excessive wear or damage.
- Inspection of the thermostats.
- See the **Service Note** on page 51.

### NOTICE

**Although the S.A.F.E. mode can help prevent engine damage, it does not guarantee you can run your engine indefinitely without engine damage.**

### Service Note

Seek service from an authorized *Evinrude* dealer, repair shop, or person of your own choosing for maintenance, repair, or replacement. Please refer to the US EPA EMISSION-RELATED WARRANTY contained herein for information about warranty claims.

### Emergency Start Procedure

**IMPORTANT:** *Evinrude E-TEC G2* models use a dedicated remote control network for all remote control-related functions.

In the event network communication between the remote control and the engine *EMM* is disabled, back-up remote control function is provided using the *NMEA 2000* network.

Start the engine using the following procedure:

- 1) Turn the key switch to the ON position.

**Note:** The NEUTRAL LED indicator on the remote control will flash rapidly, and digital displays may show a network communication service code or warning.

- 2) Use the trim switch on the starboard side of the engine to momentarily activate the trim system.
- 3) Turn the key switch to the START position or press the START button within 10 seconds of activating the trim system.

In multiple engine applications, repeat this procedure for each engine.

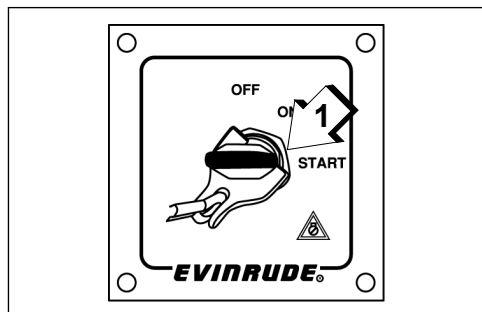

1. Key switch START position

009048

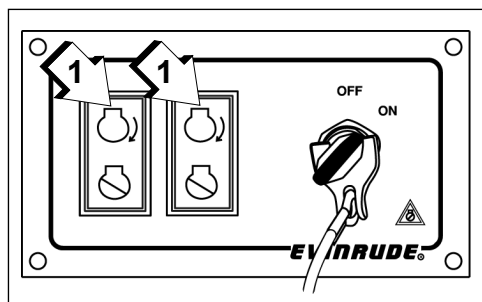

1. Start buttons

009158

***EVINRUDE***®  
***E-TEC***®



---

# **Product Information**

# Installation

## ⚠ WARNING

Your outboard must not exceed the maximum horsepower indicated on the boat's capacity plate. Such overpowering can cause loss of control. Contact your Dealer or the boat's manufacturer if your boat lacks a capacity plate.

Incorrectly matched boat and outboard transom heights can cause boat instability and loss of control. Refer to Transom Height.

Prevent lateral movement and possible outboard loss by using the mounting hardware supplied or hardware of sufficient size, strength, and quality. Refer to Installing the Outboard on page 55.

A mounting surface that is damaged or too thin to support your outboard while underway might fail during operation, causing a loss of control. Be sure the boat's transom or mounting bracket is structurally sound and between 1 3/4 in. (45 mm) and 2 3/4 in. (70 mm) in thickness.

## NOTICE

Use an appropriate hoist to lift the engine. Refer to Specifications on page 60 for engine weight.

## Transom Height

Make sure the transom height matches the length of the outboard to be installed.

- A 19 to 21 in. (48.3 to 53.3 cm) transom height uses a 20 in. (50.8 cm) shaft outboard.
- The shaft length of the outboard being installed should come close to matching the transom height of the boat.
- Refer to **Specifications** on page 60 for transom height.

Determine transom height by measuring from the top edge of the transom, along the centerline.

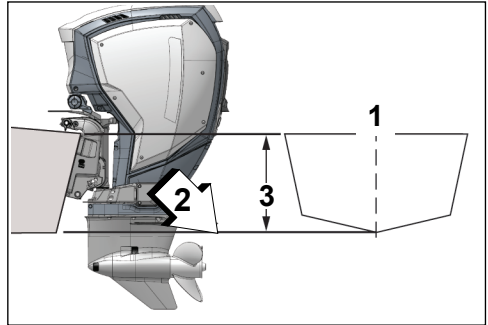

1. Centerline
2. Antiventilation plate
3. Transom Height

0009077

Boat performance depends on outboard mounting height.

Generally, the anti-ventilation plate of the gearcase should align approximately 1 in. (25 mm) above the bottom of the hull.

Test outboard and boat performance at different heights until the best performance is achieved.

**IMPORTANT:** Be sure that outboard water pressure is not adversely affected by the mounting height of the outboard.

## Outboard Shipping Cover

### NOTICE

Remove the outboard shipping cover **BEFORE** running the outboard. The shipping cover does **NOT** provide adequate air flow to run the engine.

Remove shipping carton. Remove the outboard shipping cover.



1. Shipping cover

009150

If the engine cover panel kit is not available, the shipping cover can be reinstalled to store the outboard short term.

Discard the outboard shipping cover after the engine cover panels are installed.

### NOTICE

**Do not install the shipping cover after the engine cover panels are installed, the decals or covers could be scratched.**

## Installing the Outboard

### ⚠ WARNING

**The outboard must be correctly installed. Failure to correctly install the outboard could result in serious injury, death or property damage.**

**BRP recommends your Dealer install your outboard to ensure proper installation, set-up and satisfactory performance.**

**If you install the outboard yourself, follow the instructions in the Installation and Predelivery Guide, available from your Dealer.**

### ⚠ CAUTION

**Improperly supporting an engine during lifting can result in personal injury or damage to the engine, boat or other property.**

**Verify the hoist has the correct lifting capacity for the engine weight.**

**An Engine Lift Fixture, P/N 357667, is REQUIRED to safely lift the engine. Do NOT substitute any other lifting device.**

**To avoid personal injury or damage to engine, boat or property, always install the fixture completely into the flywheel.**

**To properly install the fixture, carefully thread the fixture into the flywheel at least 6 complete turns. Do NOT cross-thread or over-torque the fixture.**

**Refer to the Installation & Predelivery Guide.**

**IMPORTANT:** Follow all directions carefully. The outboard's warranty will not cover product damage or failure that results from incorrect outboard installation.

## Boat-Mounted Fuel Filters

Boat-mounted fuel filters and water-separating fuel filter assemblies must meet the following requirements:

- **Fuel flow** – 0.4 in. Hg maximum pressure drop at 20 gph (76 l/hr) flow.
- **Filter area** – 150 in.<sup>2</sup> (1290 cm<sup>2</sup>) of filter area.

The filter must be mounted to a rigid surface above the full level of the fuel tank and accessible for servicing.

Fuel Filter Assembly, P/N 174176, meets all requirements for a water-separating fuel filter.

If equipped, replace the boat-mounted fuel filter annually.

## Battery

### **⚠ WARNING**

Battery electrolyte is acidic — handle with care. If electrolyte contacts any part of the body, immediately flush with water and seek medical attention.

Do not use a booster battery and jumper cables to start the outboard. Gasoline fumes can cause explosion and fire, resulting in property damage, personal injury or death.

### **⚠ WARNING**

Keep battery connections clean, tight, and insulated to prevent their shorting or arcing and causing an explosion. If the battery mounting system does not cover the connections, install covers. Check often to see that connections stay clean and tight.

### **Requirements**

- 12-volt, heavy-duty, designated for "marine" use;
- Vented/refillable or maintenance-free; and
- Rated according to the minimum requirements in **Specifications** on page 60.

Deep-cycle batteries are suitable **IF** they meet or exceed the minimum CCA requirements.

Ask your Dealer about your outboard's requirements before installing longer battery cables or a battery switch.

### **Installation**

### **⚠ WARNING**

Read and understand the safety information supplied with your battery **BEFORE** installation.

### **NOTICE**

Be sure all components are clean and free of corrosion. Connect **RED (+)** cable to the positive (+) post first. Connect **BLACK (-)** cable to negative (-) post last.

### **NOTICE**

**DO NOT** use wing nuts on battery connections even if they came with the battery. Wing nuts can loosen and cause errant warning signals or electrical system damage.

**Marine Battery Posts** — install each main cable on the post with a star washer below it.



1. Main cable
2. Starwasher
3. Terminal insulator

009166

**Battery Terminal Adapter Kit, P/N 385407** — install the main cable on the adapter with a star washer below it. Install wires from accessories on the threaded portion of the post.

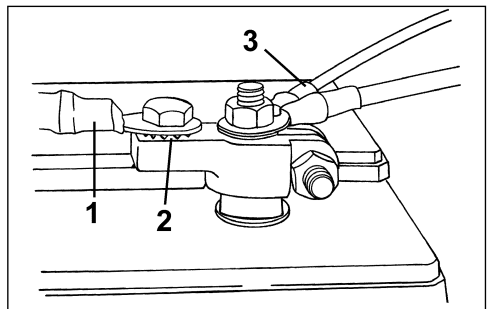

1. Main cable
2. Starwasher
3. Accessory wires

DR6495

**Automotive Type Battery Posts** — Use Battery Terminal Adapter Kit, P/N 385407. Place a star washer on the adapter first, then the



main cable. Install wires from the accessories on the main cable.

at the same time. See your Dealer to order and install this kit (P/N 5009079).

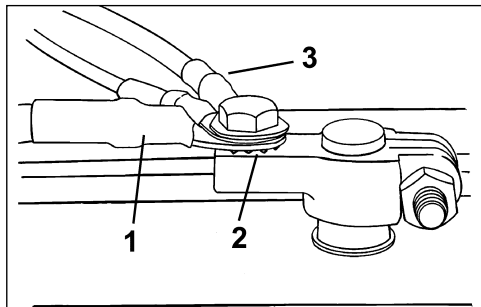

1. Main cable  
2. Starwasher  
3. Accessory wires  
DR6496

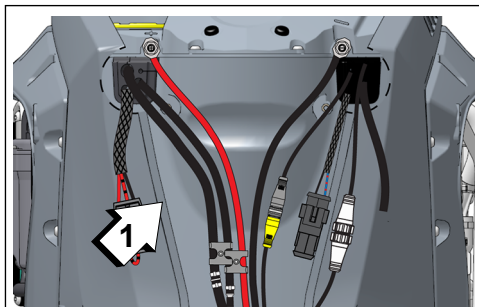

1. Accessory battery connector 009118

Tighten all connections securely and coat the installation with *Triple-Guard* grease.

**IMPORTANT:** The accessory battery connection must only be used to charge a single 12-volt battery or two 12-volt batteries wired in parallel. The accessory connection must not be used to charge either battery in a 24-volt system.

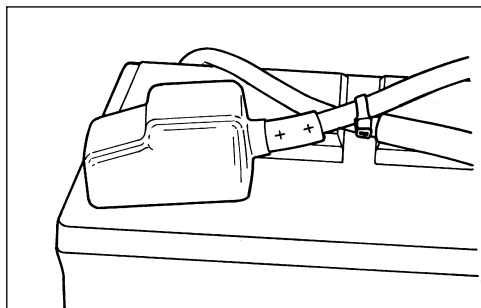

DR5104

### Water Pressure

An optional water pressure gauge is recommended to monitor cooling system pressures. Noticing changes in water pressure can help prevent engine overheating. The water pressure gauge must be connected at the correct point to ensure the most accurate pressure readings.

### Service

Follow the installation instructions included with the water pressure gauge.

#### NOTICE

**Service electrical components only while the outboard is NOT running. Be careful when identifying positive and negative battery cables and posts.**

Note: Use of *Evinrude Diagnostics* software is **REQUIRED** to activate this feature. See your authorized *Evinrude* dealer for this service.

Before servicing the battery or the outboard, remove both battery cables from the battery, battery negative (–) cable first. Keep metal objects from contacting either battery post.

### Accessory Battery Connection

An optional accessory battery charge kit is available to allow the charging system to charge the cranking and accessory batteries

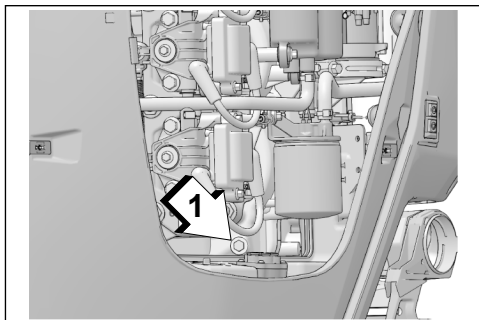

1. Water pressure port (starboard) 009078

## Propeller

### Propeller Selection

To select the correct propeller for your boating application, your boat and outboard MUST be water tested. See your Dealer for assistance.

**IMPORTANT:** The correct propeller for your boat, under normal load conditions, will allow the engine to run near the midpoint of the RPM operating range at full throttle. Refer to **Specifications** on page 60.

### **⚠ WARNING**

When servicing the propeller, always shift the outboard to **NEUTRAL** position, turn the key switch **OFF** and remove the key, so the outboard cannot be started accidentally.

### Standard vs. Counter Rotation

Right-hand propellers are considered standard rotation propellers. When propelling a boat forward, the propeller rotates in a right-hand (clockwise) direction as viewed from the rear.

Left-hand propellers are considered counter rotation propellers. When propelling a boat forward, the propeller rotates in a left-hand (counterclockwise) direction as viewed from the rear.

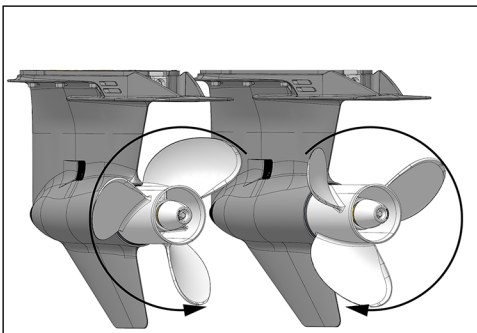

009079

### **⚠ WARNING**

In multiple outboard installations, check to make sure correct propellers are installed on each outboard before aggressively operating your boat. Shift each engine individually into **FORWARD** or **REVERSE**, at idle speed only. If the boat moves opposite the direction indicated by the remote control handle, the wrong propeller has been installed on the outboard being checked.

### Installation

### **NOTICE**

Apply *Triple-Guard* grease to the entire propeller shaft before installing the propeller.

Slide thrust washer onto shaft with shoulder facing aft.

Slide propeller onto shaft, engaging the splines and seating it on the thrust bushing.

Slide spacer onto the shaft and engage the propeller shaft splines.

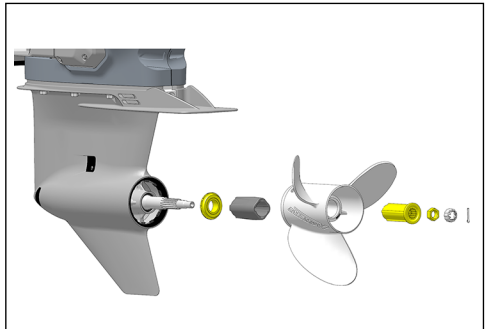

Propeller Hardware – Typical

009080

Wedge a block of wood between the propeller blade and the anti-ventilation plate.

Install propeller nut and tighten to a torque of 70 to 80 ft. lbs. (95 to 109 N·m). Install keeper on propeller nut, align keeper slots and cotter pin hole.

**IMPORTANT:** If cotter pin holes in the propeller nut and propeller shaft are not aligned,

tighten the nut until they are in line. Do not loosen.

Install new cotter pin and bend ends to secure.

Remove block of wood. Make sure engine is in NEUTRAL; give propeller a spin. It must turn freely.

Install the anode and screw on the propeller shaft. Tighten the screw to 177 to 204 in. lbs. (20 to 23 N·m).

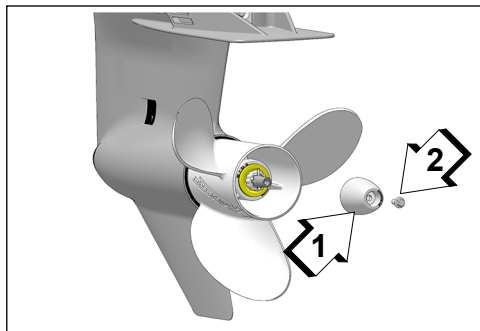

1. Anode
2. Screw

009081

### Repair

If your propeller hits a solid object, the impact is partially absorbed by the bushing in the hub to help prevent damage to the outboard. A strong impact can damage the hub and propeller blades. Damage to blades can cause unusual and excessive vibration. Damage to the hub can cause excessive engine RPM with little forward movement.

### NOTICE

**Avoid or limit operation using a damaged propeller. You may want to carry a spare propeller.**

Keep your propeller in good condition. Use a file to smooth slight damage to blade edges. See your Dealer for repair of serious damage.

## Adjustments

### Tilt Limit

Set the tilt limit if your outboard contacts the boat's motor well while tilting.

### Manual Method

**IMPORTANT:** You MUST use the trim switch on the starboard engine cover to set the tilt limit with this method.

Tilt the engine up to the desired maximum tilt position.

Then, simultaneously press both the up and down trim buttons and hold for at least three seconds.

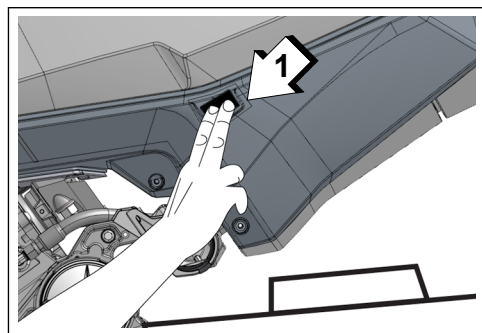

1. Trim switch

009142

To change or clear this setting, tilt the engine to the full down position.

Then, simultaneously press both the up and down trim buttons and hold for at least three seconds.

### Diagnostic Software Method

Your Dealer must use *Evinrude Diagnostic* software to limit maximum tilt-up.

Check your adjustment — tilt the outboard fully and adjust further, if necessary. Check after each adjustment.

# Specifications

## 200, 225, 250, 300 HP (3.4 Liter, 74° V6) Models

|   |  |
|---|--|
| Displacement  | 210 cu. in. (3441 cc)  |
| Engine Type   | 74° V, 6 Cylinder, Two-Cycle, <i>E-TEC</i>   |
| Full Throttle Operating Range                         | <b>200 HP</b> – 5400 to 6000 RPM<br><b>225 HP</b> – 5400 to 6000 RPM<br><b>250 HP</b> – 5400 to 6000 RPM<br><b>300 HP</b> – 5400 to 6000 RPM   |
| Power <sup>(1)</sup>                                  | <b>200 HP</b> – 200 HP (147.1 kw) @ 5500 RPM<br><b>225 HP</b> – 225 HP (165.49 kw) @ 5500 RPM<br><b>250 HP</b> – 250 HP (183.87 kw) @ 5500RPM<br><b>250 H.O.</b> – 250 HP (183.87 kw) @ 5500 RPM<br><b>300 HP</b> – 300 HP (220.65 kw) @ 5500 RPM                              |
| Idle RPM in Neutral <sup>(2)</sup>                    | 500 ± 50   |
| Idle RPM in Gear <sup>(2)</sup>                       | 500 ± 50   |
| Ignition Timing <sup>(2)</sup>                        | Controlled by the outboard's <i>EMM</i>  |
| Emission Control System: per SAE J1930 <sup>(2)</sup> | ECM, <i>E-TEC</i> (Engine Control Module, <i>E-TEC</i> )   |
| Fuel Requirements <sup>(2)</sup>                      | Refer to <b>Fuel Requirements</b> on page 15   |
| Oil<br>– Lubricant<br><br>– Capacity                  | <i>Evinrude XD</i> <sup>†</sup> oils or a synthetic TC-W3 NMMA-certified oil<br>– Refer to <b>2-Stroke Engine Oil Requirements</b> on page 14<br>2.0 gallons (7.5 liters)<br><sup>†</sup> <i>Evinrude XD</i> oils exceed the specifications of <i>NMMA TC-W3</i> certification |
| Warning Signals                                       | Controlled by the outboard's <i>EMM</i>  |
| Battery, Minimum <sup>(3)</sup>                       | 675 CCA (845 MCA) 12 volt or<br>800 CCA (1000 MCA) 12 volt below 32°F (0°C)  |
| Spark Plug <sup>(2)</sup><br>– Type<br>– Gap          | Champion <b>QC8WEPI</b><br>0.028 in. (0.71 mm)   |
| Fuses   | Refer to <b>Fuses</b> on page 45   |
| Fuel Filters<br>– Inline<br>– Water Separating        | P/N 357797<br>P/N 502906   |
| Battery Charging                                      | 50-Amp, Fully Regulated, Dual Isolated   |
| Hydraulic Steering Fluid                              | Use ONLY SeaStar Hydraulic fluid, P/N 770891   |
| Power Trim/Tilt<br>– Fluid<br>– Capacity              | <i>Power Trim/Tilt Fluid</i> , P/N 767969<br>24 fl. oz. (710 ml)   |

|   |   |
|---|---|
| Gearcase – Lubricant <sup>(4)</sup><br>– Capacity | <i>Evinrude HPF Pro</i> Gearcase Lubricant<br><b>Gearcase (Standard Rotation, 0.54 ratio)</b><br>Gearcase only – 37.3 fl. oz. (1103 ml)<br>Gearcase, vent hose and oil bottle 43 fl. oz. (1273 ml)<br><b>Gearcase (Counter Rotation, 0.54 ratio)</b><br>Gearcase only – 39 fl. oz. (1154 ml)<br>Gearcase, vent hose and oil bottle 44.7 fl. oz. (1324 ml) |
| Propeller   | Refer to <b>Propeller Selection</b> on page 58  |
| Weight  | <b>L Models</b> – 537 lbs. (TBD kg)<br><b>X Models</b> – 558 lbs. (TBD kg)<br><b>Z Models</b> – 570 lbs. (TBD kg)   |
| Sound at Driver's Ear (LpA) ICOMIA 39.94          | 88.0 dBA  |
| Pass By Noise Level ISO 14509                     | 71.7 dBA  |
| Transom Height                                    | <b>L Models</b> – 19 1/2 to 20 in. (495 to 508 mm)<br><b>X Models</b> – 24 1/2 to 25 in. (622 to 635 mm)<br><b>Z Models</b> – 29 1/2 to 30 in. (749 to 762 mm)  |

- (1) Rated following the standards of ICOMIA 28.83, ISO 3046 and NMMA.
- (2) Emission Control Information.
- (3) Under extraordinary electrical load or environmental conditions, use a 107 amp-hour minimum battery (generally available in group 29 size).
- (4) Use *Evinrude HPF Pro* Gearcase Lubricant for high performance outboards and commercial applications. *Evinrude HPF Pro* Gearcase Lubricant delivers exceptional durability and reliability and promotes long gearcase life in marine use.

***EVINRUDE***®  
***E-TEC***®



# Product Warranty Information

## BRP US Inc. Limited Warranty For *Evinrude*® Outboard Engines

### 1. Scope Of The Limited Warranty

BRP US Inc.\* ("BRP")\* warrants its *Evinrude*® outboard engines (the "Product") sold by distributors or dealers authorized by BRP to distribute *Evinrude*® outboard engines (the "OE Distributor/Dealer") from defects in material or workmanship for the period and under the conditions described below.

All genuine *Evinrude*® parts and accessories, including but not limited to propellers, gauges, oil tanks, remote controls, wiring and key switches installed by an authorized OE Distributor/Dealer at the time of delivery of the Product bear the standard BRP limited warranty for *Evinrude*® genuine parts and accessories. See your authorized OE Distributor/Dealer for a full copy of such limited warranty.

This limited warranty will become null and void if:

(1) Product was used for racing or any other competitive activity, at any point, even by a previous owner; or (2) Product has been altered or modified in such a way so as to adversely affect its operation, performance or durability, or (3) the Product has been altered or modified to change its intended use, horsepower or emission levels.

### 2. Exclusions — The following are not warranted under any circumstances:

- Replacement of parts due to normal wear and tear;
- Outboard jet pumps that are added to outboards and parts contained there in;
- Routine maintenance parts and services including but not limited to: maintenance requirements, engine and lower unit oil changes, lubrication, valve and linkage adjustments and replacement of fuses, zinc anodes, thermostats, timing belts, filters, propellers;
- Damage caused by improper or lack of installation, maintenance, winterization and/or storage, failure to follow the procedures and recommendations in the Operator's Guide;
- Damage resulting from removal of parts, improper repairs, service, maintenance, or modification, or use of parts or accessories not manufactured or approved by BRP, which in its reasonable judgment, are either incompatible with Product or adversely affect its operation, performance, or durability, or resulting from repairs done by a person that is not an authorized OE Distributor/Dealer (as described below);
- Damage caused by abuse, misuse, abnormal use, neglect, racing, improper operation or operation of the Product in a manner inconsistent with the recommended operation described in the Operator's Guide;
- Damage resulting from external damage, accident, submersion, water ingestion, fire, theft, vandalism or any act of God;
- Operation without proper fuel, oil or lubrication, or with fuels, oils or lubricants which are not suitable for use with the Product (see the Operator's Guide);
- Damage resulting from rust;
- Damage resulting from corrosion (for G2™ engines - see *Evinrude*® E-TEC® G2™ Limited Corrosion Warranty);
- Damage caused from cooling system blockage by foreign material;
- Damage resulting from sand or debris in the water pump;
- Cosmetic or paint changes due to exposure to the elements;
- Incidental or consequential damages, or damages of any kind including without limitation expense for gasoline, expense for transporting Product to and from OE Distributor/Dealer, removal of Product from a boat and reinstallation, mechanic's travel time, in-and-out of water charges, slip or dock fees, trailering or towing, storage, telephone, cell phone, fax charges, rental of a like or replacement Product or boat during warranty services or down time, taxi, travel, lodging, loss of or damage to personal property, inconvenience, cost of insurance coverage, loan payments, loss of time, loss of income, revenue or profits, or loss of enjoyment or use of Product.

### 3. Limitations of Liability

TO THE EXTENT PERMITTED BY LAW, THIS WARRANTY IS EXPRESSLY GIVEN AND ACCEPTED IN LIEU OF ANY AND ALL OTHER WARRANTIES, EXPRESSED OR IMPLIED, INCLUDING WITHOUT LIMITATION ANY WARRANTY OF MERCHANTABILITY OR FITNESS FOR A PARTICULAR PURPOSE. TO THE EXTENT THAT THEY CANNOT BE DISCLAIMED, THE IMPLIED WARRANTIES ARE LIMITED IN DURATION TO THE LIFE OF THE EXPRESS LIMITED WARRANTY.

INCIDENTAL, AND CONSEQUENTIAL DAMAGES ARE EXCLUDED FROM COVERAGE UNDER THIS LIMITED WARRANTY.

SOME COUNTRIES, STATES, PROVINCES, OR JURISDICTIONS DO NOT ALLOW FOR THE DISCLAIMERS, LIMITATIONS AND EXCLUSIONS IDENTIFIED ABOVE. AS A RESULT, THEY MAY NOT APPLY TO YOU. THIS LIMITED WARRANTY GIVES YOU SPECIFIC RIGHTS, AND YOU MAY ALSO HAVE OTHER LEGAL RIGHTS WHICH MAY VARY FROM COUNTRY TO COUNTRY, STATE TO STATE, OR PROVINCE TO PROVINCE. (FOR PRODUCTS PURCHASED IN AUSTRALIA SEE CLAUSE 4 BELOW).

Neither the OE Distributor /Dealer nor any other person has been authorized to make any affirmation, representation or warranty regarding the Product other than those contained in this limited warranty and, if made, shall not be enforceable against BRP. BRP reserves the right to modify this limited warranty at any time, being understood that such modification will not alter the warranty conditions applicable to the Products sold while this limited warranty is in effect. If a Product is purchased under a governmental contract, the terms of such contract supersede the terms stated herein.

### 4. Warranty Coverage Period

This limited warranty will be in effect (1) from the date of delivery to the first retail consumer or (2) the date the Product is first put to use, whichever occurs first, and for the applicable period below:

1. Private or recreational use: THIRTY-SIX (36) CONSECUTIVE MONTHS; or
2. Commercial use:

Products sold in Canada or United States: as agreed at the time of purchase at the OE Distributor/ Dealer and as registered by OE Distributor/Dealer in BOSSWeb, either:

(i) twelve (12) CONSECUTIVE MONTHS UNLIMITED HOURS; or

(ii) thirty-six (36) CONSECUTIVE MONTHS or 750 HOURS OF OPERATION as determined by Product Engine Management Module (EMM) whichever occurs (first).

Products sold outside Canada or United States: TWELVE (12) CONSECUTIVE MONTHS or 750 HOURS OF OPERATION as determined by Product Engine Management Module (EMM), whichever occurs first.

\*Exceptions applicable to commercial use only:

(i) Exhaust emission-related components: SIXTY (60) CONSECUTIVE MONTHS or ONE HUNDRED SEVENTY FIVE (175) HOURS of engine use, whichever occurs first.; and

(ii) Evaporative emission related components: TWENTY-FOUR (24) CONSECUTIVE MONTHS.

The Product is used commercially when it is used in connection with any work or employment that generates income, during any part of the limited warranty period. The Product is also used commercially when, at any point during the limited warranty period, it is installed on a boat that has commercial tags or is licensed for commercial use. Please see your Authorized *Evinrude* Outboard Engine Distributor/Dealer for emission-related service. In cases where the delivery date is not established to BRP's satisfaction, the date of sale will be used to determine the warranty start date.

3. For emission-related components; please also refer to the US EPA EMISSION-RELATED WARRANTY contained herein.
4. For *Evinrude* outboard engines produced by BRP for sale in the State of California that are originally sold to a resident or subsequently warranty registered to a resident in the State of California, please also refer to the applicable California Emissions Control Warranty Statement contained herein

See your Dealer or your BRP Extended Service Terms (*B.E.S.T.*) contract for terms and conditions.



The repair or replacement of parts or the performance of service to Product under this limited warranty does not extend the life of this limited warranty beyond its original expiration date.

California residents who purchased or warranty-registered a Product in California should refer to BRP's California Emissions Control Warranty Statement.

Note that the duration and any other modalities of the warranty coverage are subject to the applicable national or local legislation in the customer's country.

#### **FOR PRODUCTS SOLD IN AUSTRALIA ONLY**

Nothing in these Warranty terms and conditions should be taken to exclude, restrict or modify the application of any condition, warranty, guarantee, right or remedy conferred or implied under the Competition and Consumer Act 2010 (Cth), including the Australian Consumer Law or any other law, where to do so would contravene that law, or cause any part of these terms and conditions to be void. The benefits given to you under this limited warranty are in addition to other rights and remedies that you have under Australian law.

Our goods come with guarantees that cannot be excluded under the Australian Consumer Law. You are entitled to a replacement or refund for a major failure and for compensation for any other reasonably foreseeable loss or damage. You are also entitled to have the goods repaired or replaced if the goods fail to be of acceptable quality and the failure does not amount to a major failure.

### **5. Conditions to Have Warranty Coverage**

This limited warranty coverage is available only if each of the following conditions has been fulfilled:

The Product must be purchased as new and unused by its first owner from an OE Distributor/Dealer authorized to distribute *Evinrude* products in the country in which the sale occurred;

- The BRP specified pre-delivery inspection process must be completed, documented and signed by the purchaser and Distributor/Dealer;
- The Product must have undergone proper registration by an authorized OE Distributor/Dealer;
- The Product must be purchased in the country in which the purchaser resides; and
- Routine maintenance outlined in the Operator's Guide must be timely performed in order to maintain warranty coverage. BRP reserves the right to make warranty coverage contingent upon proof of proper maintenance as outlined in the maintenance schedule, proper service, pre-ride inspection and storage conditions.

BRP will not honor this limited warranty to any private use owner or commercial use owner if the preceding conditions have not been met. Such limitations are necessary in order to allow BRP to preserve both the safety of its products, and also that of its consumers and the general public.

### **6. What to do to Obtain Warranty Coverage**

The customer must cease using the Product upon appearance of an anomaly.

The registered owner must notify an authorized servicing OE Distributor/ Dealer within two (2) days of the appearance of a defect. BRP is not responsible for damages caused by the use of a Product after the appearance of a defect. Owner must bring Product, including any defective part therein, to OE Distributor/ Dealer promptly after the appearance of the defect, and in any event, within the warranty period, and must provide OE Distributor/Dealer with reasonable opportunity to repair the defect. The expenses of transporting Product to and from OE Distributor/Dealer for warranty service are to be borne by the owner.

The owner may also be required to present proof of purchase to OE Distributor/Dealer and is required to sign the repair work order prior to the start of the repair in order to validate the warranty repair.

All parts replaced under this limited warranty become the property of BRP.

Note that the notification period is subject to the applicable national or local legislation in customer's country.

## **7. What BRP Will Do**

To the extent permitted by law, BRP's obligations under this limited warranty are limited to, at its sole discretion, repairing or replacing parts of Product found to be defective in material or workmanship, in the reasonable judgment of BRP. Such repair or replacement of parts will be done without charge for parts and labor, at any authorized OE Distributor/Dealer. BRP's responsibility is limited to making the required repairs or replacements of parts with new or BRP-certified re-manufactured parts. No claim of breach of warranty shall be cause for cancellation or rescission of the sale of Product to owner.

In the event that warranty service is required outside of the country of original sale, the owner will bear responsibility for any additional charges due to local practices and conditions, such as, but not limited to, freight, insurance, taxes, license fees, import duties, and any and all other financial charges, including those levied by governments, states, territories and their respective agencies.

BRP reserves the right to improve, modify or change Products from time to time without assuming any obligation to modify Products previously manufactured.

## **8. Transfer**

If the ownership of a Product is transferred during the limited warranty coverage period, this limited warranty, subject to its terms and conditions, shall also be transferred and be valid for the remaining coverage period provided that BRP or an authorized Distributor/Dealer receives a proof that the former owner agreed to the transfer of ownership, in addition to the co-ordinates of the new-owner.

## **9. Consumer Assistance**

In the event of a controversy or dispute in connection with this BRP limited warranty, BRP recommends that you first try to resolve the issue at the dealership level by discussing the issue with OE Distributor/Dealer's service manager or owner;

If further assistance is required, please contact BRP US Inc., Attn: Consumer Support, P.O. Box 597, Sturtevant, WI 53177, 1-844-345-4277

For countries within European Economic Area, Middle East and Africa please contact our European office: BRP EUROPE N.V. Customer Assistance Center Skaldenstraat 125 9042 Gent Belgium Tel.: + 32 9 218 26 00.

For Scandinavian countries, please contact our Finland office: BRP FINLAND OY, Service department, Ahjotie 30, Fin-96320, Rovaniemi, Finland Tel.: +358 16 3208 111.

For all other countries, please contact your local Can-Am ATV Distributor/Dealer (visit our website at [www.brp.com](http://www.brp.com) for contact information), or contact our North American office at: BOMBARDIER RECREATIONAL PRODUCTS INC. Customer Assistance Center 75, J.-A. Bombardier Street Sherbrooke QC J1L 1W3 Canada Tel.: + 1 819 566-3366.

In Canada, Products are distributed and serviced by Bombardier Recreational Products Inc. In the European Economic Area and elsewhere, Products are distributed and serviced by BRP European Distribution SA and other affiliates of Bombardier Recreational Products Inc.

® Registered trademark of Bombardier Recreational Products Inc. or its affiliates.

© 2016 BRP US Inc. All rights reserved.

### ***Additional Terms and Conditions for France Only***

The following terms and conditions are applicable to products sold in France only:

The seller shall deliver goods that are complying with the contract and shall be responsible for defects existing upon delivery. The seller shall also be responsible for defects resulting from packaging, assembling instructions or the installation when it is its responsibility per the contract or if accomplished under its responsibility. To be compliant with the contract, the good shall:

1. Be fit for normal use for goods similar thereto and, if applicable:
  - Correspond to the description provided by the seller and have the qualities presented to the buyer through sample or model;
  - Have the qualities that a buyer may legitimately expect considering the public declarations of the seller, the manufacturer of its representative, including in advertising or labeling; or
2. Have the characteristics mutually agreed upon as between the parties or be fit for the specific use intended by the buyer and brought to the attention of the seller and which accepted.

The action for failure to comply is prescribed after two years after delivery of the goods. The seller is responsible for the warranty for hidden defects of the good sold if such hidden defects are rendering the good unfit for the intended use, or if they diminish its use in such a way that the buyer would not have acquired the good or would have given a lesser price, had he known. The action for such hidden defects shall be taken by the buyer within 2 years of the discovery of the defect.

\* Engines sold in Canada are distributed and serviced by Bombardier Recreational Products Inc.

\* In the European Economic Area and elsewhere, Products are distributed and serviced by BRP European Distribution S.A. and other subsidiaries of BRP.

Limited Warranty Revision August 2014

# BRP US Inc. Limited Corrosion Warranty For *Evinrude*® *E-TEC*® *G2*™ Engines

**What is covered:** BRP US Inc. (BRP) warrants that each new *Evinrude*® *E-TEC*® *G2*™ engine sold by authorized *Evinrude* dealers ("Product") will not be rendered inoperative as a direct result of corrosion for the period of time described below.

**Duration of coverage:** This limited corrosion warranty will be in effect from the date of delivery to the first retail consumer or the date the Product is first put to use, whichever occurs first, for a period of five (5) years. The repair or replacement of parts, or the performance of service under this limited corrosion warranty, does not extend the life of this limited corrosion warranty beyond its original expiration date. Unexpired warranty coverage can be transferred to a subsequent (non-commercial use) purchaser upon proper registration of the Product.

## Warranty Information

### Conditions required for warranty coverage:

This limited corrosion warranty is available **only** if **each** of the following conditions has been fulfilled:

- The Product must be purchased as new and unused by its first owner from an authorized *Evinrude*® dealer ("Dealer") authorized to distribute products in the country in which the sale occurred;
- The BRP specified pre-delivery inspection process must be completed and documented and signed by the Dealer and the purchaser ("Owner");
- The Product must have undergone proper registration by a Dealer;
- The Product must be purchased in the country in which the Owner resides;
- Corrosion prevention devices specified in the Operation and Maintenance Manual must be in use on the boat; and
- Routine maintenance outlined in the Operator's Guide and Service Manual must be timely performed (including, without limitation, the replacement of sacrificial anodes, use of specified lubricants, and paint touch-up of nicks and scratches) in order to maintain warranty coverage. BRP reserves the right to make warranty coverage contingent upon proof of proper maintenance by a Dealer.

**Exclusions:** The following are not warranted under any circumstances:

- Corrosion damage caused by stray electrical currents (on-shore power connections, nearby boats, submerged metal).
- Damage caused by improper application of copper base anti-fouling paints.
- Electrical system corrosion;
- Corrosion resulting from damage,
- Corrosion which causes purely cosmetic damage,
- Abuse, or improper service;
- Corrosion to accessories, instruments, steering systems;
- Damage due to marine growth;
- Replacement parts (parts purchased by Owner);
- Products used in a commercial application. Commercial use is defined as any work or employment related use of the Product, or any use of the Product which generates income, for any part of the warranty period, even if the Product is only occasionally used for such purposes.

If anti-fouling protection is required, Bis (tributyltin) adipate (TBTA) base anti-fouling paints are recommended on *Evinrude*® engine boating applications. In areas where TBTA base paints are prohibited by law, copper base paints can be used on the hull and transom. Do not apply paint to the Product. In addition, care must be taken to avoid an electrical interconnection between the Product and the paint.

**What to do to obtain warranty coverage:** The registered Owner must notify an authorized Dealer within two (2) days of the appearance of a defect. BRP is not responsible for damages caused by the use of a Product after the appearance of a defect. Owner must bring Product, including any defective part therein, to Dealer promptly after the appearance of the defect, and in any event, within the warranty period, and must provide Dealer with reasonable opportunity to repair the defect. The expenses of transporting Product to and from Dealer for warranty service are to be borne by the owner.

If the Product has not previously been registered, the Owner may also be required to present proof of purchase to Dealer for warranty repairs. Owner is required to sign the repair work order prior to the start of the repair in order to validate the warranty repair.

All parts replaced under this warranty become the property of BRP.

**What BRP will do:** BRP's sole and exclusive obligation under this limited corrosion warranty is limited to, at BRP's option, repairing a corroded part, replacing such part or parts with new genuine or *Evinrude*® certified remanufactured parts, or refunding the purchase price of the Product. BRP reserves the right to improve or modify products from time to time without assuming an obligation to modify products previously manufactured.

**TRANSFER:** If the ownership of Product is transferred during the warranty coverage period, this warranty shall also be transferred and be valid for the remaining coverage period provided that BRP is notified of such transfer of ownership in the following way:

1. The former owner contacts BRP (at the phone number provided below) or a Dealer and gives the coordinates of the new owner; or
2. BRP or a Dealer receives a proof that the former owner agreed to the transfer of ownership, in addition to the coordinates of the new owner.

### **Consumer Assistance**

In the event of a controversy or dispute in connection with this BRP limited corrosion warranty, BRP recommends that you first try to resolve the issue at the dealership level by discussing the issue with Dealer's service manager or owner;

If further assistance is required, please refer to **Consumer Assistance** on page 66 for regional contact information.

\* Engines sold in Canada are distributed and serviced by Bombardier Recreational Products Inc.

® Registered trademark of Bombardier Recreational Products Inc. or its affiliates.

© 2014 BRP US Inc. All rights reserved.

## US EPA Emission Warranty

BRP US Inc. ("BRP")\* warrants to the ultimate purchaser and each subsequent purchaser that this new engine, including all parts of its exhaust emission control system and its evaporative emission control system, meets two conditions:

1. It is designed, built, and equipped so it conforms at the time of sale to the ultimate purchaser with the requirements of 40 CFR 1045 and 40 CFR 1060.
2. It is free from defects in materials and workmanship that may keep it from meeting the requirements of 40 CFR 1045 and 40 CFR 1060.

Where a warrantable condition exists, BRP will repair or replace, as it elects, any part or component with a defect in materials or workmanship that would increase the engine's emissions of any regulated pollutant within the stated warranty period at no cost to the owner, including expenses related to diagnosing and repairing or replacing emission-related parts. All defective parts replaced under this warranty become the property of BRP.

For all emission-related warranty claims, BRP is limiting the diagnosis and repair of emission-related parts to the authorized *Evinrude* dealers, unless for emergency repairs as required by item 2 of the following list.

As a certifying manufacturer, BRP will not deny emission-related warranty claims based on any of the following:

1. Maintenance or other service BRP or BRP's authorized facilities performed.
2. Engine/equipment repair work that an operator performed to correct an unsafe, emergency condition attributable to BRP as long as the operator tries to restore the engine/equipment to its proper configuration as soon as possible.
3. Any action or inaction by the operator unrelated to the warranty claim.
4. Maintenance that was performed more frequently than BRP specify.
5. Anything that is BRP fault or responsibility.
6. The use of any fuel that is commonly available where the equipment operates unless BRP written maintenance instructions state that this fuel would harm the equipment's emission control system and operators can readily find the proper fuel. See maintenance information section and fuel requirements section.

### ***Emission Related Warranty Period***

The emission-related warranty is valid for the following period whichever comes first:

|   | <b>HOURS</b> | <b>MONTHS</b> |
|---|--------------|---------------|
| Exhaust emission-related components     | 175          | 60            |
| Evaporative emission-related components | N/A          | 24            |

## Components Covered

The emission-related warranty covers all components whose failure would increase an engine's emissions of any regulated pollutant, including the following listed components:

1. For exhaust emissions, emission-related components include any engine parts related to the following systems:
  - Air-induction system
  - Fuel system
  - Ignition system
  - Exhaust gas recirculation systems
2. The following parts are also considered emission-related components for exhaust emissions:
  - After-treatment devices
  - Crankcase ventilation valves
  - Sensors
  - Electronic control units
3. The following parts are considered emission-related components for evaporative emissions:
  - Fuel tank
  - Fuel cap
  - Fuel line
  - Fuel line fittings
  - Clamps\*
  - Pressure relief valves\*
  - Control valves\*
  - Control solenoids\*
  - Electronic controls\*
  - Vacuum control diaphragms\*
  - Control cables\*
  - Control linkages\*
  - Purge valves
  - Vapor hoses
  - Liquid/vapor separator
  - Carbon canister
  - Canister mounting brackets
  - Carburetor purge port connector
4. Emission-related components also include any other part whose only purpose is to reduce emissions or whose failure will increase emissions without significantly degrading engine/equipment performance.

\*As related to the evaporative emission control system

## Limited Applicability

As a certifying manufacturer, BRP may deny emission-related warranty claims for failures that have been caused by the owner's or operator's improper maintenance or use, by accidents for which the manufacturer has no responsibility, or by acts of God. For example, an emission-related warranty claim need not be honored for failures that have been directly caused by the operator's abuse of the engine/equipment or the operator's use of the engine/equipment in a manner for which it was not designed and are not attributable to the manufacturer in anyway.

# California Emission Control Warranty Statement

Your *Evinrude E-TEC G2* outboard has a special environmental label required by the California Air Resources Board. The label has one, two, three, or four stars. A hangtag, provided with your outboard, describes the meaning of the star rating system.

## *The Star Label Means Cleaner Marine Engines*



The Symbol for Cleaner Marine Engines:

### **Cleaner Air and Water**

For a healthier lifestyle and environment.

### **Better Fuel Economy**

Burns up to 30 to 40 percent less gas and oil than conventional carbureted two-stroke engines, saving money and resources.

### **Longer Emission Warranty**

Protects consumer for worry free operation.

## ***One Star – Low Emission***

The one-star label identifies Personal Watercraft, Outboard, Sterndrive and Inboard engines that meet the Air Resource Board's Personal Watercraft and Outboard marine engine 2001 exhaust emission standards. Engines meeting these standards have 75% lower emissions than conventional carbureted two-stroke engines. These engines are equivalent to the U.S. EPA's 2006 standards for marine engines.

## ***Two Stars – Very Low Emission***

The two-star label identifies Personal Watercraft, Outboard, Sterndrive and Inboard engines that meet the Air Resources Board's Personal Watercraft and Outboard marine engine 2004 exhaust emission standards. Engines meeting these standards have 20% lower emissions than One Star – Low Emission engines.

## ***Three Stars – Ultra Low Emission***

The three-star label identifies engines that meet the Air Resources Board's Personal Watercraft and Outboard marine engine 2008 exhaust emission standards or the Sterndrive and Inboard marine engine 2003 exhaust emission standards. Engines meeting these standards have 65% lower emissions than One Star – Low Emission engines.

## ***Four Stars – Super Ultra Low Emission***

The four-star label identifies engines that meet the Air Resources Board's Sterndrive and Inboard marine engine 2009 exhaust emission standards. Personal Watercraft and Outboard marine engines may also comply with these standards. Engines meeting these standards have 90% lower emission than One Star – Low Emission engines.

For more information: Cleaner Watercraft – Get the Facts

1-800-END-SMOG

[www.arb.ca.gov](http://www.arb.ca.gov)



## Your Emission Control Warranty Rights and Obligation

The California Air Resources Board and Bombardier Recreational Products (“BRP”) are pleased to explain the emission control system warranty on your *Evinrude E-TEC G2* outboard. In California, new outboard engines must be designed, built, and equipped to meet the State’s stringent anti-smog standards. BRP must warrant the emission control system on your outboard for the periods of time listed below provided there has been no abuse, neglect, or improper maintenance of your outboard.

Your emission control system may include parts such as the carburetor or fuel injection system, the ignition system, and catalytic converter. Also included may be hoses, belts, connectors, and other emission-related assemblies.

Where a warrantable condition exists, BRP will repair your outboard at no cost to you including diagnosis, parts, and labor provided that such work is performed by an authorized BRP dealer.

### Manufacturer’s Limited Warranty Coverage

This emission limited warranty covers *Evinrude* outboards certified and produced by BRP for sale in California, that are originally sold in California to a California resident, or subsequently warranty-registered to a California resident. The BRP U.S. and Canada limited warranty conditions for *Evinrude* outboards are still applicable to these models with the necessary modifications.

Select emission control parts of your *Evinrude E-TEC G2* outboard are warranted from the date of purchase by the first retail consumer or the date the product is first put to use, whichever occurs first, for a period of: 4 years, or for 250 hours of use, whichever occurs first.

However, warranty coverage based on the hourly period is only permitted for outboards equipped with the appropriate hour meters or their equivalent. If any emission-related part on your engine is defective under warranty, the part will be repaired or replaced by BRP.

Parts covered are:

|                                     |                                    |
|-------------------------------------|------------------------------------|
| <b>1. Electrical System</b>         | <b>4. Air Induction System</b>     |
| A. EMM (Engine Management Module)   | A. Reed Valves                     |
| B. Spark Plugs and Wires            | B. Throttle Body Assembly          |
| C. Ignition Coils                   | C. Intake Manifold                 |
| D. Wiring Harness                   |                                    |
|                                     | <b>5. Oil System</b>               |
| <b>2. Exhaust System</b>            | A. Oil Injector                    |
| A. Inner Exhaust Housing            | B. Oil Lines, Fittings, and Clamps |
| B. Adapter (Exhaust Manifold)       |                                    |
| C. Megaphone (Inner Exhaust)        | <b>6. Sensors</b>                  |
|                                     | A. Air Temperature Sensor          |
| <b>3. Fuel System</b>               | B. Crank Position Sensor           |
| A. Fuel Lift Pump                   | C. Throttle Position Sensor        |
| B. Fuel Supply Pump                 | D. Water Temperature Sensor        |
| C. Fuel Injectors                   | E. Thermostat                      |
| D. Vapor Separator                  |                                    |
| E. Fuel Lines, Fittings, and Clamps | <b>7. Gaskets</b>                  |
|                                     | A. All Emission Component Gaskets  |

The emission warranty covers damage to other engine components that is caused by the failure of a warranted part.

The BRP Operator’s Guide provided contains written instructions for the proper maintenance and use of your outboard. All emission warranty parts are warranted by BRP for the entire warranty period of the outboard, unless the part is scheduled for replacement as required maintenance in the Operator’s Guide.

Emission warranty parts that are scheduled for replacement, as required maintenance, are warranted by BRP for the period of time before the first scheduled replacement date for that part. Emission warranty parts that are scheduled for regular inspection but not regular replacement are warranted by BRP for the entire warranty period of the outboard. Any emission warranty part repaired or replaced under the terms of this warranty statement is warranted by BRP for the remainder of the warranty period of the original part. All parts replaced under this limited warranty become the property of BRP.

Maintenance receipts and records should be transferred to each subsequent owner of the outboard.

### **Owner's Warranty Responsibilities**

As the outboard owner, you are responsible for the performance of the required maintenance listed in your Operator's Guide. BRP recommends that you retain all receipts covering maintenance on your outboard, but BRP cannot deny warranty solely for the lack of receipts or your failure to ensure the performance of all scheduled maintenance.

As the outboard owner, you should however be aware that BRP may deny you warranty coverage if your outboard or a part has failed due to abuse, neglect, improper maintenance, or unapproved modifications.

You are responsible for presenting your outboard to an authorized BRP dealer as soon as a problem exists. The warranty repairs will be completed in a reasonable amount of time, not to exceed 30 days.

For any questions regarding your warranty rights and responsibilities or for the name and location of the nearest authorized BRP dealer, contact:

BRP US Inc. / Marine Propulsion Systems,  
After Sales Support,  
P.O Box 597,  
Sturtevant, WI 53177,  
1-844-345-4277

or visit [www.evinrude.com](http://www.evinrude.com).

# Readiness Test

The Operator's Readiness Test...

1. Did you read this Guide from front cover to rear cover?
2. Are you ready to take responsibility for the safe operation of your boat and outboard?
3. Do you understand all the safety precautions and instructions contained in this Guide?
4. Do you understand that this Guide contains essential information to help prevent personal injury and damage to equipment?
5. Are you ready to follow the recommendations in this Guide and take a boating safety course before you operate your boat and outboard?
6. Do you know who to ask if you have any questions about your boat and outboard?
7. Do you know your local marine traffic laws?
8. Do you understand that human error can be caused by carelessness, fatigue, overload, preoccupation, unfamiliarity of operator with the product, drugs and alcohol, just to name a few?

## **WARNING**

**It is impossible for this Guide to cover every hazardous situation you may encounter; however, your understanding of and adherence to essential information contained in this Guide will build good judgment when boating. Always be alert and careful: a good foundation for safety.**

***EVINRUDE***®  
***E-TEC***®



# Frequently Asked Questions

*No dealer-scheduled maintenance for five years or 500 hours of normal recreational use? Really?*

- Yes! BRP knows you want to spend your time out on the water, not servicing your *Evinrude E-TEC G2* outboard. There are no valves to adjust, belts to service, chains to replace, or oil to change. We do recommend pre-launch inspections of your outboard at each use and at regular intervals. Salt water applications require minimal additional inspections and lubrication.

*What fuel octane is recommended for my Evinrude E-TEC G2 outboard?*

- *Evinrude E-TEC G2* outboards require a minimum octane rating 87 {AKI (R+M)/2} in the U.S. and Canada, or 90 {RON} outside of the U.S. and Canada. Use of higher octane fuels is not harmful, but also not necessary.

*What kind of oil does my Evinrude E-TEC G2 outboard require?*

- *Evinrude XD100 Direct Injection Oil* and *Evinrude XD50 2-Stroke Oil* are recommended for your *Evinrude E-TEC G2* outboard. When operating in conditions under 32°F (0°C), *Evinrude XD100* oil must be used.

*Do I need to mix oil into my fuel?*

- No. *Evinrude E-TEC G2* outboards do not require any mixing of oil and fuel.

*Can I order replacement parts and accessories for my Evinrude E-TEC G2 outboard?*

- Yes. When replacement parts are required, use *Evinrude* Genuine Parts or parts with equivalent characteristics, including type, strength, and material. Using substandard parts could result in injury or product malfunction. Your dealer can order the parts and accessories you desire.

*Do I need to complete any paperwork when I move or sell my Evinrude E-TEC G2 outboard?*

- Yes. In order to maintain contact with you or the new *Evinrude E-TEC G2* owner, BRP requests you complete the form outlining **Change of Address / Change of Ownership** on page 79. This will ensure you or the new owner is made aware of any product announcements and keep the warranty coverage up-to-date.

*What do I need to do before storing my Evinrude E-TEC G2 outboard for the winter?*

- Winterization is minimal. Refer to **Storage** on page 47 for step-by-step instructions to store your *Evinrude E-TEC G2* outboard for the off-season.

***EVINRUDE***®  
***E-TEC***®



# Change of Address / Change of Ownership

If your address has changed or if there has been a change of ownership, be sure to fill out and mail the form provided on this page.

This notification is necessary for your own safety even after expiration of the original warranty, since BRP will be in a position to contact you if correction to your outboard is required. Outside the U.S. and Canada, this card should be sent to the Bombardier Recreational Products division where the outboard was registered. Please contact your Dealer or Distributor.



Change of Address

Change of Ownership

Model number

Serial Number

## Old Address / Previous Owner

Last name

First name  M.I.

Address

City  State

Zip code  Country

Phone number

Signature \_\_\_\_\_ Date \_\_\_\_\_

## New Address / New Owner

Type of Use  Recreational  Commercial  Government

Last name

First name  M.I.

Address

City  State

Zip code  Country

Phone number

Signature \_\_\_\_\_ Date \_\_\_\_\_

## Dealer Information

Dealer name

Dealer number

Phone number

Contact name

In the U.S. or Canada, mail completed form to: BRP US Inc. / Marine Propulsion Systems  
After Sales Support  
P.O. Box 597  
Sturtevant, WI 53177

***EVINRUDE***®  
***E-TEC***®





# Confirmation of Receipt

## Your Dealer

|          |       |
|----------|-------|
| Name:    | _____ |
| Address: | _____ |
|          | _____ |
|          | _____ |

Upon delivery of your new *Evinrude* outboard, complete and sign the form below. Your Dealer will take receipt of the form for their records.

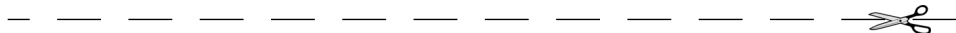

## Receipt

|   |       |
|---|-------|
| Name:   | _____ |
| Address:  | _____ |
|   | _____ |
| Owner of Model No:  | _____ |
| Serial No:  | _____ |
| (To be completed by customer or selling Dealer)   |       |
| The Dealer named on this document has instructed me on the operation, maintenance, safety features and warranty policy, all of which I understand and agree to be bound with. I am also satisfied with the predelivery set-up and inspection of my <i>Evinrude</i> outboard. I have also received a copy of the Operator's Guide. |       |
| Signature:  | _____ |
| Date:   | _____ |
|   | _____ |

***EVINRUDE***®  
***E-TEC***®





*www.brp.com*



**SKI-DOO®**  
**LYNX®**

**SEA-DOO®**  
**EVINRUDE®**

**CAN-AM®**  
**ROTAX®**