

# SEA·DOO® JET BOATS

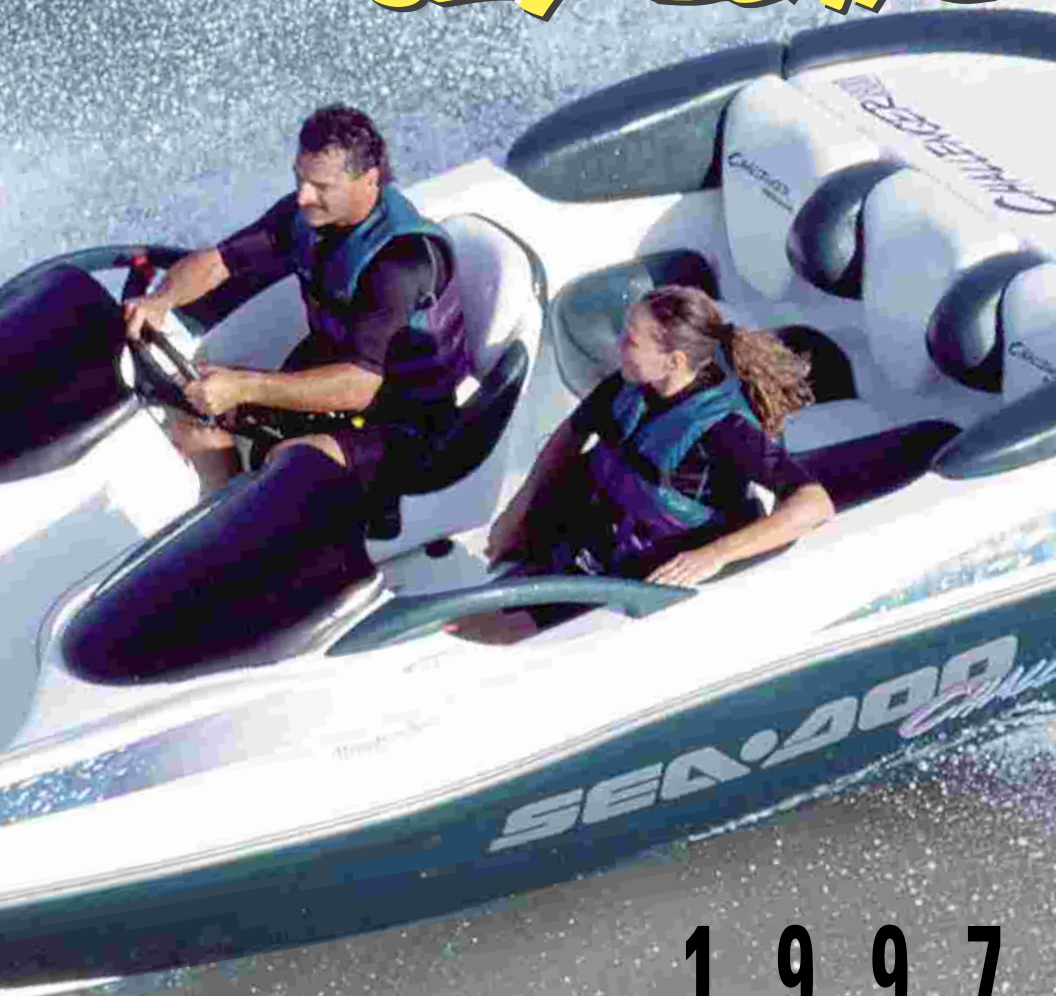

EXPLORER 5824

1 9 9 7  
OPERATOR'S  
GUIDE

2 1 9 0 0 0 0 6 7

◆ **SAFETY WARNING**

Disregarding any of the safety precautions and instructions contained in this *Operator's Guide*, the *Safety Handbook* and on *Warning Labels* could cause injury, including the possibility of death.

This *Operator's Guide*, *Safety Handbook* and the *Safety videocassette* should remain with the jet boat at the time of resale.

AFTER-SALES  
SERVICE  
BOMBARDIER INC.  
VALCOURT (QUÉBEC)  
CANADA J0E 2L0



**The following trademarks are property of  
Bombardier Inc.:**

SEA-DOO®  
Bombardier Lube®  
Sea-Doo Jet Pump Synthetic Oil  
Sea-Doo Synthetic Grease

Gelcote® is a trademark of Gelcote International

---

## **Doin't it on your new Sea-Doo Explorer Jet Boat**

Congratulations, you are now the proud owner of a jet boat. Whether you are an experienced boater or are new to the sport of boating, we ask you to take the time to view the *Safety videocassette* provided with your jet boat, read this *Operator Guide* and the *Safety handbook* and familiarize yourself with its contents. The Guide contains pertinent information which, if followed, will provide you with the necessary knowledge to help you fully enjoy the pleasures of this craft.

We strongly recommend that any boat operator complete a safety boating course. Check with your local Coast Guard or Power and Sail Squadron in your area for course availability. More serious boaters may want to obtain "***Chapman Piloting***" by Elbert S. Maloney, available at most book stores.

When introducing your family or friends to the sport, be sure they fully understand the controls and operation of the jet boat and the importance of courteous, responsible riding.

Each jet boat operator has a responsibility to ensure the safety of its passengers and other water users. Please follow all safety instruction and drive with care.

Finally, we invite you to visit your dealer for regular safety maintenance as well as any boating accessories you may require.

Have fun and .....Bon Voyage.

# TABLE OF CONTENTS

---

<b>FOREWORD .....</b>	<b>5</b>
<b>◆SAFETY WARNING.....</b>	<b>6</b>
<b>LIST OF DISTRIBUTORS .....</b>	<b>9</b>
<b>BOMBARDIER LIMITED WARRANTY: 1997 SEA- DOO® JET BOAT</b>	<b>10</b>
<b>REGISTRATION NUMBER LOCATION.....</b>	<b>12</b>
<b>LOCATION OF THE IMPORTANT LABELS .....</b>	<b>13</b>
<b>JET BOAT IDENTIFICATION.....</b>	<b>14</b>
Hull Identification Number.....	14
Tube Identification Number.....	14
Jet Boat Model Number.....	14
Engine Identification Number.....	14
<b>COMPONENT FUNCTIONS .....</b>	<b>15</b>
1) Safety Lanyard Switch.....	17
2) Handlebar.....	17
3) Throttle Lever.....	17
4) Choke Lever.....	17
5) Light Switch.....	18
6) Engine Cover Latch.....	18
7) Boarding Platform.....	18
8) Cooling System Bleed Outlet.....	19
9) Bilge Drain Plugs.....	19
10) Jet Pump Nozzle.....	19
11) Air Intake Openings.....	19
12) Fuel Tank Cap.....	20
13) Reverse Gate.....	20
14) Rear Vent Grills.....	20
15) Stern Eyelet.....	20
16) Deck.....	20
17) Grab Handles.....	20
18) Fuel Valve.....	20
19) Selector Lever.....	21
20) Engine Overheating Beeper.....	21
21) Engine Start/Stop Button.....	21
22) Rear Storage Compartment Cover.....	21
23) Rear Storage Compartment.....	21
24) Tool Kit.....	21
25) Navigation Lights.....	22
26) Front Storage Cover Latch.....	23
27) Front Storage Compartment.....	23
28) Fuel Gauge/Low Oil Warning Light.....	23
29) Oil Injection Reservoir Cap.....	23

30) Engine Compartment.....	23
31) Access Covers .....	23
32) Jet Pump Water Intake .....	23
33) Deck Drain Holes .....	24
34) Bow Eyelet.....	24
35) Deck Eyelets .....	24
36) Inflatable Tube .....	24
37) Inflatable Tube Valves .....	24
38) Air Blower Switch .....	24
39) Flushing Connector.....	24
<b>FUEL AND LUBRICATION .....</b>	<b>25</b>
Fueling Procedure .....	25
Recommended Fuel .....	25
Recommended Oil .....	25
Oil Injection System .....	25
<b>BREAK-IN PERIOD .....</b>	<b>26</b>
Engine .....	26
10-Hour Inspection .....	26
<b>PRE-OPERATION CHECKS .....</b>	<b>28</b>
Hull .....	28
Jet Pump Water Intake .....	28
Bilge .....	29
Battery.....	29
Fuel and Oil Reservoirs .....	29
Engine Compartment .....	29
Fire Extinguisher.....	29
Steering and Throttle Systems.....	29
Reverse System .....	29
Safety Lanyard and Engine Start/Stop Button .....	29
Inflatable Tube.....	30
Clothing .....	30
<b>OPERATING INSTRUCTIONS .....</b>	<b>31</b>
Principle of Operation.....	31
Boarding from a Dock or in Shallow Water .....	32
Starting the Engine.....	32
Obstacles .....	33
Boarding in Deep Water .....	34
Rough Water Operation .....	35
Crossing Waves/Wakes .....	35
Stopping/Docking .....	35
Beaching.....	36
Shutting Off the Engine.....	36

---

Night Time Operation .....	36
<b>POST-OPERATION CARE.....</b>	<b>37</b>
General Care .....	37
Additional Care for Foul Water or Salt Water .....	37
Anticorrosion Treatment.....	39
<b>SPECIAL PROCEDURES.....</b>	<b>40</b>
Engine Overheat.....	40
Jet Pump Water Intake and Impeller Cleaning .....	40
Capsized Boat.....	40
Submerged Boat.....	41
Towing the Boat .....	41
Low-Charge Battery Condition .....	42
<b>MAINTENANCE .....</b>	<b>43</b>
Lubrication .....	43
Periodic Inspection .....	45
Periodic Inspection Chart.....	46
Throttle and Choke Cable Inspection.....	47
Carburetor Adjustment .....	47
Fuel and Oil Filters.....	47
Steering Alignment.....	47
Reverse Gate Adjustment .....	48
Vacuum Bailer Pick-Ups and Deck Drain Holes .....	48
Fuses .....	48
Air Blower.....	49
Zinc Anode.....	49
Light Bulb Replacement .....	49
Tube Inflation .....	51
Order of Inflation .....	52
Tube Deflation .....	52
Tube Minor Repairs .....	52
General Inspection and Care .....	53
<b>TRANSPORTATION, STORAGE AND PRE-SEASON PREPARATION 54</b>	
Transportation.....	54
Storage .....	54
Pre-Season Preparation .....	57
<b>TROUBLESHOOTING .....</b>	<b>59</b>
<b>SPECIFICATIONS .....</b>	<b>61</b>
<b>SI METRIC INFORMATION GUIDE.....</b>	<b>63</b>
<b>CHANGE OF ADDRESS.....</b>	<b>65</b>

# FOREWORD

---

The *Operator's Guide* has been prepared to acquaint the owner/operator or passenger of this jet boat with the various jet boat controls, maintenance and safe riding instructions. It is indispensable for the proper use of the product, and should be kept in a waterproof bag in the jet boat at all times.

For any questions pertaining to the warranty and its application, please consult the WARRANTY section in this guide, or an authorized SEA-DOO jet boat dealer.

This guide uses the following symbols to emphasize particular information.



## WARNING

Identifies an instruction which, if not followed, might cause serious personal injuries including the possibility of death.



## CAUTION

Denotes an instruction which, if not followed, might severely damage the jet boat and/or components.

**NOTE:** Indicates supplementary information needed to fully complete an instruction.

Although the mere reading of such information does not eliminate the hazard, the understanding and application of the information will promote its correct use.

The information and components/system descriptions contained in this guide are correct at the time of publication. Bombardier Inc. however, maintains a policy of continuous improvement of its products without imposing upon itself any obligation to install them on products previously manufactured.

The illustrations show the typical construction of the different assemblies and may not represent the full detail or exact shape of the parts which have the same or a similar function.

Specifications are given in the SI metric system with the SAE U.S. equivalent in parenthesis. Where precise accuracy is not required, some conversions are rounded off for easier use.

A *Shop Manual* can be obtained for complete service, maintenance and repair information.



## WARNING

The engine and the corresponding components identified in this guide should not be utilized on product(s) other than those they were designed for. Maintenance procedures and specified tightening torques must be strictly adhered to. Never attempt repairs unless the appropriate tools are available. This jet boat is designed with parts dimensioned in both the metric and the imperial systems. When replacing fasteners, make sure to use only those recommended by Bombardier. Mismatched or incorrect fasteners could cause damage to the jet boat or possible personal injury.

**NOTE:** The following list gives the equivalent of terms commonly used to designate boat references.

Port: LH side

Starboard: RH side

Bow: Front

Stern: Rear

## ◆ SAFETY WARNING

---

To fully appreciate the pleasures, enjoyment and excitement of boating there are some basic rules that **MUST** be observed and followed by any boater. Some rules may be new to you while others may be common sense or obvious, nevertheless, we ask that you please take a few minutes of your time to read these safety instructions completely before you operate your craft. **Failure to follow this safety information and safe boating rules could result in injury, including the possibility of death to you, your passenger(s), or other water users.**

Information in this Guide is limited. It is strongly recommended that you obtain further boating information from the local Coast Guard or Power Squadron. We further recommend you take a boating safety course. Check local and federal boating laws applicable to the waterways where you intend to use the craft. Learn the local rules of the road.

Always carry all required safety equipment. Verify it regularly.

Become completely familiar with the controls and operation of the craft before taking on a passenger(s) or embarking on a trip. If you have not had the opportunity to do so with your dealer, practice driving solo in a suitable area. Be fully familiar with all controls before fully applying the throttle.

Observe and follow all on-product warning labels and the content of this Guide.

Operator and passenger(s) should wear suitable eye and body protection from wind and water as well as deck shoes or booties.

Coast Guard approved personal flotation devices (PFD) should be worn by all aboard.

Operation of this craft by a minor or disabled person is **NOT** recommended.

Do not operate the craft after consuming alcohol or drugs.

Store or tie-down any loose articles or necessary boating equipment before operating the craft.

Always perform the pre-operational checks as specified in this Guide. This includes:

- Attaching the safety lanyard.
- Verification of throttle lever and steering movement.
- Verification of start/stop button operation.
- Oil and fuel levels.
- Use of blower.
- Adequate water depth.
- Functional navigation lights.
- Required boating equipment. (Know how to use each).

The operator and passenger(s) must be properly seated in the designated seats before starting or moving the craft. Allow no one to jump into the boat at anytime, or move during boat operation. The risk of an accidental fall or slip is always present.

Ensure operator all-round visibility is unrestricted.

Wave or wake jumping is dangerous and in many regions illegal.



---

Most boating accidents result from the failure of the operator to keep a lookout for other water users or other potential hazards. Keep a safe distance from other boat on water. Do not attempt to splash others with your wake. Do not ride surf line.

This craft is equipped with bow and stern navigation lights which should be used as required. Lower speed and do not operate the craft in reduced visibility.

To prevent accidental starting or unauthorized use, always detach the safety lanyard from the boat during maintenance, cleaning of the intake grate, or when swimmers are nearby.

Ensure that all passengers know how to reboard the craft from the water.

Always have an observer while towing a skier.

Know the waters in which the craft is to be operated. Current, tides, rapids, shallow water, hidden obstacles etc., can affect safe operation.

When boating, apply the principle of 1/3 fuel to destination, 1/3 back and 1/3 reserve fuel supply.

Maintain the craft and equipment in top condition at all times. Adhere to the prescribed maintenance schedules. Use a protective cover when not in use. After salt or foul water use, the craft should be thoroughly rinsed and protected from corrosion. If you suspect water ingestion into the engine, contact your dealer for proper servicing.

The bilge must be kept clean of oil, water or other foreign materials. Do not carry spare fuel and inflammable liquids in any of the storage or engine compartments.

Avoid adding on accessories, carrying equipment which may alter the craft's configuration or balance. Only perform servicing procedures which are detailed in this Guide. Further assistance or information can be obtained from your dealer. In many instances proper tools and training is required for certain servicing or repair procedures.

Gasoline fumes are flammable and explosive. Always adhere to the fueling procedures contained in this Guide and those given to you by the marina.

Always keep in mind that as the throttle lever is released to idle position, less directional control is available. To turn the craft, both steering and throttle are necessary. This craft has the capability of turning more sharply than other boats, however, unless in an emergency, do not negotiate sharp, high speed turns.

Like any other boat, this craft has no brake. Stopping distance will vary depending on initial speed, load, wind, and water conditions. Practice stopping and docking in a safe area to have an idea of how long it will take to stop the craft under varying conditions.

Prolonged exposure to the sun, wind etc., causes fatigue and may affect your reaction time.

Do not overload the craft or take on more passengers than designated for the intended type of boating. Load and altitude will also affect boat performance.

Proceed with caution and at very low speeds on shallow water. Grounding or abrupt stops may result, or debris may be picked up and be jettisoned rearward to people or property. The impeller is turning even when the selector lever is at neutral.

---

As the "skipper" of a boat you are responsible for damage to other boats caused by the wake of your craft. Respect no wake zones.

Respect the rights of other water users and the environment. Allow no one to throw refuse overboard.

Do not operate the craft in inclement weather.

Constant attention and control of the boat is required by the operator for safe operation.

Use of the bilge blower should never replace "smelling" for gasoline fumes. Blower must be off during boat operation.

Lifting the craft requires special equipment and experience. Do not attempt to lift the craft without such experience or equipment.

Respect the safety and comfort of your passenger(s) and persons being towed on skis.

Drive prudently and have fun.

# LIST OF DISTRIBUTORS

---

## NORTH AMERICA

<b>U.S.A.:</b> (Continental USA except Puerto Rico)	<b>BOMBARDIER MOTOR CORPORATION OF AMERICA</b> 7575 BOMBARDIER COURT P.O. BOX 8035 WAUSAU, WI 54402-8035 Phone: (715) 842-8886
<b>CANADA</b> Alberta British Columbia Manitoba North West Territories Ontario Quebec Saskatchewan Yukon New-Brunswick Nova Scotia Prince Edward Island	<b>BOMBARDIER INC.</b> SEA-DOO SERVICE DEPARTMENT VALCOURT, QUEBEC JOE 2L0 Phone: (514) 532-22114
Newfoundland	<b>CHARLES R. BELL</b> P.O. BOX 1050 RIVERSIDE DRIVE CORNER BROOKE, NFLD A2H 6J3 Phone: (709) 634-3533 FAX: (709) 634-2444

If your SEA-DOO requires warranty service, you must take it to any authorized SEA-DOO dealer. Be sure to bring your warranty registration card or other valid proof of the original date of purchase. If a question or problem arises regarding warranty, first contact the service manager or owner of the SEA-DOO dealership.

To find the nearest authorized Sea-Doo dealer, dial: 1-800-882-2900.

○ **NOTE:** If outside North America, consult the local distributor.

# **BOMBARDIER LIMITED WARRANTY: 1997 SEA- DOO® JET BOAT**

---

## **1. WARRANTY COVERAGE PERIOD**

BOMBARDIER INC. ("Bombardier"), as manufacturer, warrants FROM THE DATE OF DELIVERY TO THE FIRST CONSUMER that each 1997 SEA-DOO jet boat sold, as NEW and UNUSED and PREDELIVERED by an authorized North American SEA-DOO jet boat dealer, will be free from any defects in material and/or workmanship for a PERIOD of:

a) For private use:

TWELVE (12) CONSECUTIVE MONTHS, with the exception for the deck and hull fiberglass structure; and

SIXTY (60) CONSECUTIVE MONTHS for the deck and hull fiberglass structure.

b) For commercial use:

FOUR (4) CONSECUTIVE MONTHS, with the exception for the deck and hull fiberglass structure; and

TWELVE (12) CONSECUTIVE MONTHS for the deck and hull fiberglass structure.

All genuine Bombardier accessories, installed by an authorized SEA-DOO jet boat dealer at the time of delivery of the new and unused SEA-DOO jet boat, carry the same Warranty Coverage Period as for the SEA-DOO jet boat.

## **2. WHAT BOMBARDIER WILL DO**

BOMBARDIER will repair or replace, at its option, all genuine BOMBARDIER part found defective in material and/or workmanship, under normal use, maintenance and service, with a genuine BOMBARDIER part without charge for parts and labor, at any authorized SEA-DOO jet boat dealer during the Warranty Coverage Period.

## **3. CONDITION TO HAVE WARRANTY WORK VALIDATED**

The customer must notify an authorized SEA-DOO jet boat dealer within two (2) days of the appearance of the defect in material and/or workmanship and present to the servicing authorized SEA-DOO jet boat dealer the SEA-DOO Warranty Registration Card or a proof of purchase of the NEW and UNUSED 1997 SEA-DOO jet boat and must sign the repair/work order prior to the start of the repair in order to validate a warranty repair. All parts replaced under this limited warranty become the property of BOMBARDIER.

## **4. EXCLUSIONS - ARE NOT WARRANTED**

- Normal wear and tear items;
- Labor, parts and lubricant costs of all maintenance services;
- Damage caused by failure to provide proper maintenance and/or storage, as described in the (1997 SEA-DOO jet boat Operator's Guide);
- Damage resulting from improper repairs, modifications or use of non-approved parts or, repairs done by a non-authorized SEA-DOO jet boat dealer;
- Damage resulting from abuse, misuse, neglect, racing;
- Damage resulting from accident, fire, theft, vandalism or any act of God;
- Incidental or consequential damages, or damages of any kind as but not limited to towing charges, telephone calls or taxi;
- Water damages caused by water ingestion;
- Damage related to gel coat finish including but not limited to cosmetic gel coat finish, blisters or fiberglass delamination caused by blisters, crazing, spider or hairline cracks; and;
- Damages resulting from improper service or maintenance.

---

## 5. LIMITATIONS OF LIABILITY

**This warranty gives you specific rights, and you may also have other legal rights which may vary from state to state, or province to province. WHERE APPLICABLE, THIS WARRANTY IS EXPRESSLY GIVEN AND ACCEPTED IN LIEU OF ANY AND ALL OTHER WARRANTIES, EXPRESSED OR IMPLIED, INCLUDING WITHOUT LIMITATION ANY WARRANTY OF MERCHANTABILITY OR FITNESS FOR ANY PARTICULAR PURPOSE.**

**Neither the distributor, any authorized SEA-DOO jet boat dealer nor any other person has been authorized to make any affirmation, representation or warranty other than those contained in this warranty, and if made, such affirmation, representation or warranty shall not be enforceable against BOMBARDIER or any other person.**

**In no event shall BOMBARDIER be liable for special, consequential or incidental damages, including but not limited to loss of use and transportation costs. Some states or provinces do not allow the exclusion or limitation of incidental or consequential damages, or limitations on how long an implied warranty lasts, so the above limitation or exclusion may not apply.**

**BOMBARDIER reserves the right to modify this warranty at any time, being understood that such modification will not alter the warranty conditions applicable to the SEA-DOO jet boat sold while this warranty is in effect.**

## 6. CONSUMER ASSISTANCE

- a) In the event of a controversy or a dispute arising in connection with this BOMBARDIER LIMITED WARRANTY, BOMBARDIER suggests that you try to resolve the issue at the dealership level. We recommend discussing the issue with the authorized dealer's service manager or owner.
- b) If further assistance is required, the DISTRIBUTOR's service department should be contacted in order to resolve the matter.
- c) If the issue has still not been resolved, please submit in writing your complaint to:

In Canada:

BOMBARDIER INC.®  
SEA-DOO/SKI-DOO Division  
Customer Assistance Center  
Valcourt, Québec  
CANADA JOE 2L0

Tel: 514-532-5000

In USA:

BOMBARDIER MOTOR  
CORPORATION OF AMERICA  
SEA-DOO/SKI-DOO Division  
Customer Assistance Center  
P.O. Box 8035  
7575 Bombardier Court  
Wausau, WI 54402-8035  
Tel: 715-848-4957

BOMBARDIER INC.  
SEA-DOO/SKI-DOO Division  
May 1996

® Registered trademark of Bombardier Inc. and/or affiliates.

# REGISTRATION NUMBER LOCATION \_\_\_\_\_

All jet boats are required by federal law to be registered and legally numbered. Due to space availability for proper display of registration number, refer to the following illustration for location. The registration number must appear on each side of jet boat.

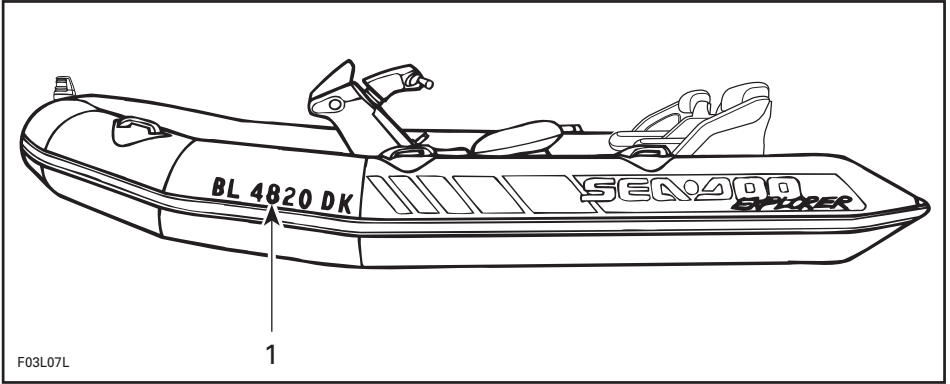

1. Registration number location

# LOCATION OF THE IMPORTANT LABELS

Please read the following labels carefully before operating this jet boat.

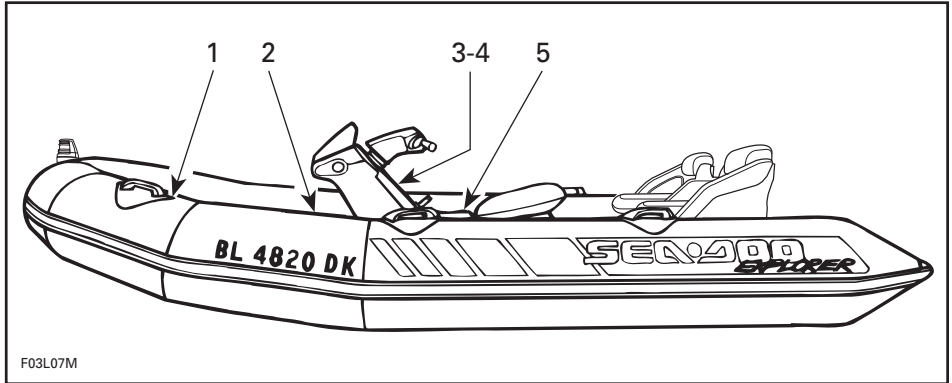

F03L07M

**1**

"THIS BOAT IS NOT REQUIRED TO COMPLY WITH THE FOLLOWING U.S. COAST GUARD SAFETY STANDARDS IN EFFECT ON THE DATE OF CERTIFICATION:

- Fuel System
- Display of Capacity Information
- Safe Loading
- Flotation
- Powered Ventilation

AS AUTHORIZED BY U.S. COAST GUARD GRANT OF EXEMPTION (CGB 88-001)."

Bombardier Corp. 7575 Bombardier Court, Wausau, WI 54401

Made in Canada Fabriqué au	Bombardier Inc. Rd./Enr., 1988	XXXX
-------------------------------	-----------------------------------	------

F01LOWY

**2**

**◆WARNING**

WHILE FUELING, STOP ENGINE. FUEL TANK MAY BE PRESSURIZED, SLOWLY TURN CAP WHEN OPENING. KEEP WATERCRAFT LEVEL. DO NOT OVERFILL. CHECK OIL LEVEL. PERIODICALLY, VERIFY FUEL SYSTEM.

F01L6V0

**3**

**REMEMBER THESE RULES OF THE ROAD**

Meeting head on: KEEP RIGHT.

Passing: Give right of way to other boat and KEEP CLEAR.

**◆WARNING**

Read & follow all Warning Labels & Operator Guide/Safety Handbook before operation. Severe injury or death can result from ignoring warnings or through improper use of watercraft.

- Carrying capacity: 1 operator and 4 passengers (1050 lbs).
- Check throttle & steering operation before starting engine.
- Directional control is lost when throttle is released or engine shut off.
- Remove debris from jet intake only when engine is turned OFF.
- Operator and passengers should always wear life vest.
- Securely attach stop switch tether to your life vest.
- This watercraft is not designed for night-time operation.
- Check all Federal & local boating regulations.
- Do not stunt or jump watercraft. Do not ride on tube.
- Check tube pressure before riding (3 Psi).
- Minimum recommended age: 14.
- Gasoline vapors can explode. Before starting engine operate blower for 4 minutes and check engine compartment bilge for gasoline vapors.

F03L1TL

**4**

**◆WARNING**

- NOT A GRAB HANDLE
- USE REVERSE ONLY AT VERY LOW SPEED

**REVERSE**

F02L2GZ

**5**

**◆WARNING**

DO NOT BOOST BATTERY. SERVICING OF ELECTRICAL COMPONENTS SHOULD BE DONE BY DEALER ONLY.

F02L2C2

# JET BOAT IDENTIFICATION

The main components of the Explorer (engine, hull and tube) are identified by different serial numbers. It may sometimes become necessary to locate these numbers for warranty purposes or to trace the jet boat in the event of theft.

## Hull Identification Number

The Hull Identification Number (H.I.N.) is located at right hand rear side of hull.

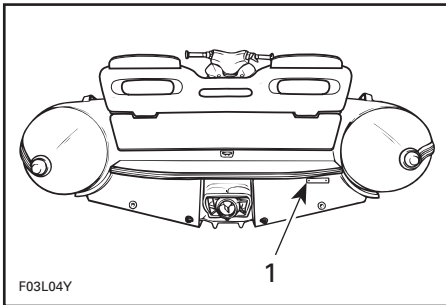

1. Hull Identification Number (H.I.N.)

## Tube Identification Number

The Tube Identification Number (T.I.N.) is located on right hand plastic cone.

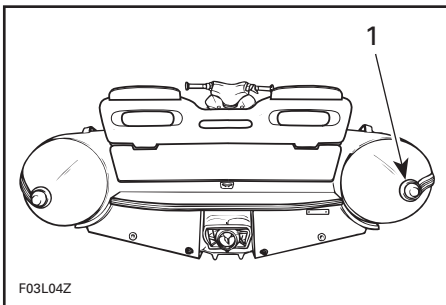

1. Tube Identification Number (T.I.N.)

## Jet Boat Model Number

The jet boat model number can be found on U.S. Coast Guard approved label located on left hand side of front storage compartment cover.

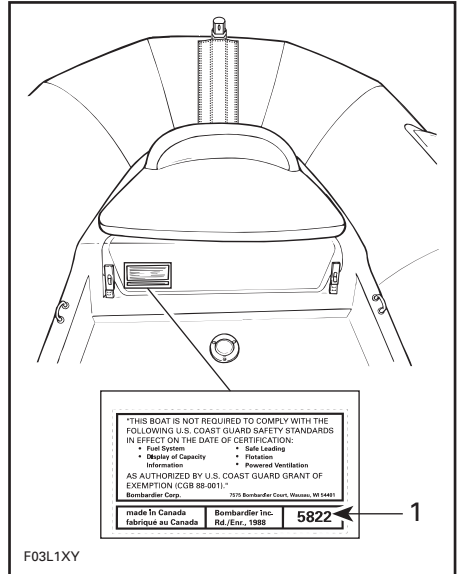

1. Model Number

## Engine Identification Number

The Engine Identification Number (E.I.N.) is located on the upper side of the magneto housing.

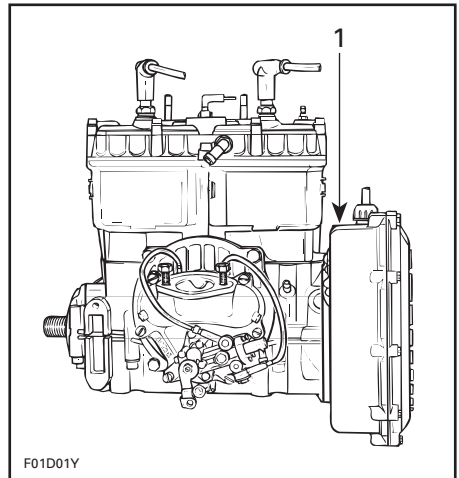

TYPICAL

1. Engine Identification Number (E.I.N.)



# COMPONENT FUNCTIONS

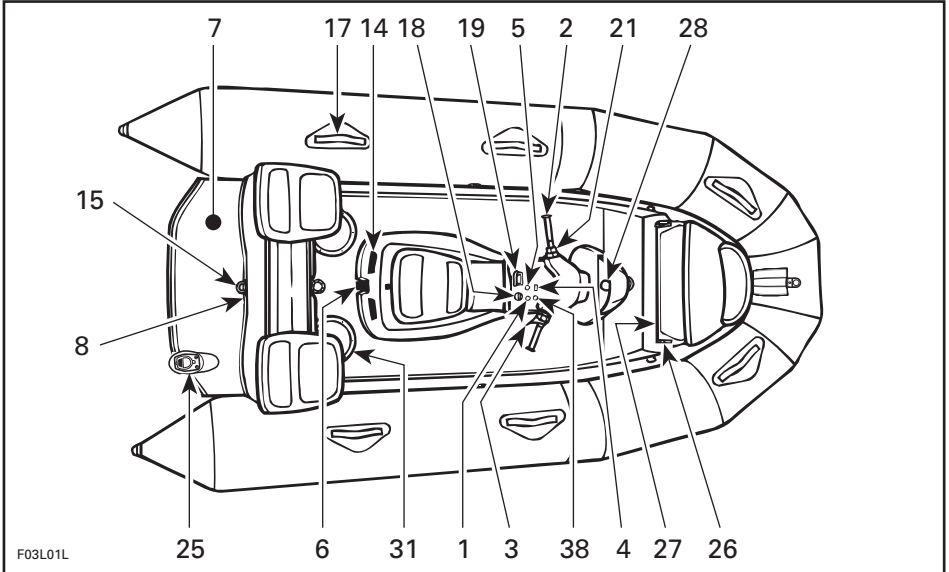

F03L01L

TOP VIEW

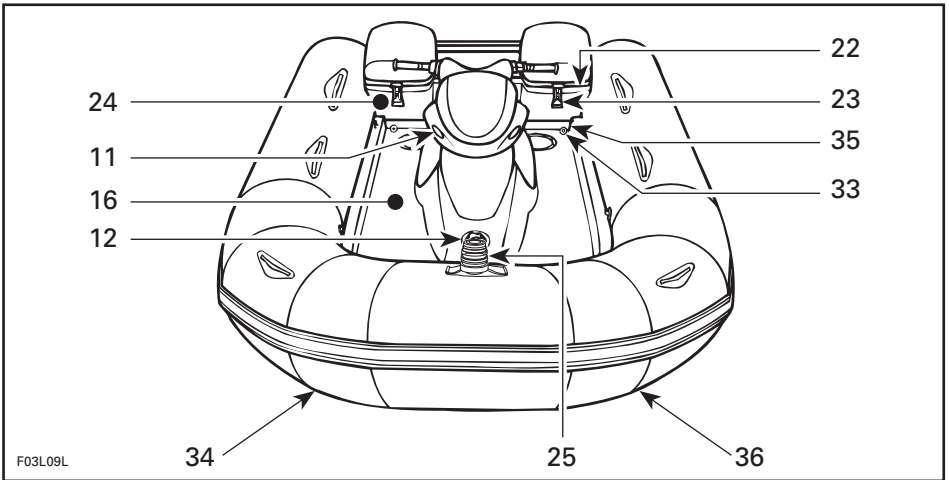

F03L09L

FRONT VIEW

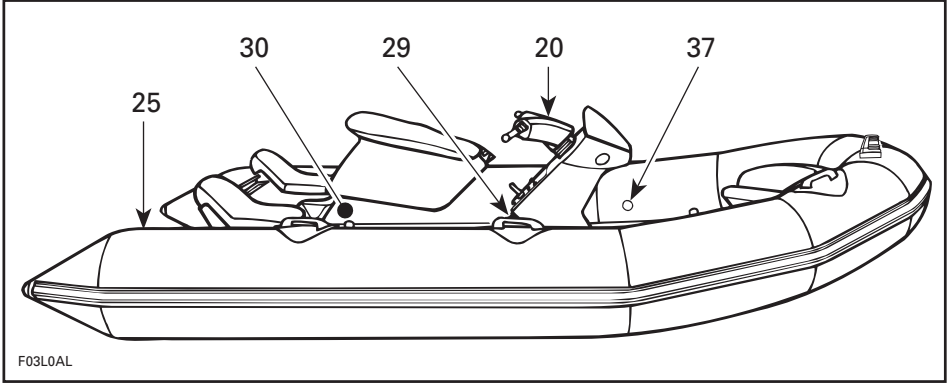

*SIDE VIEW*

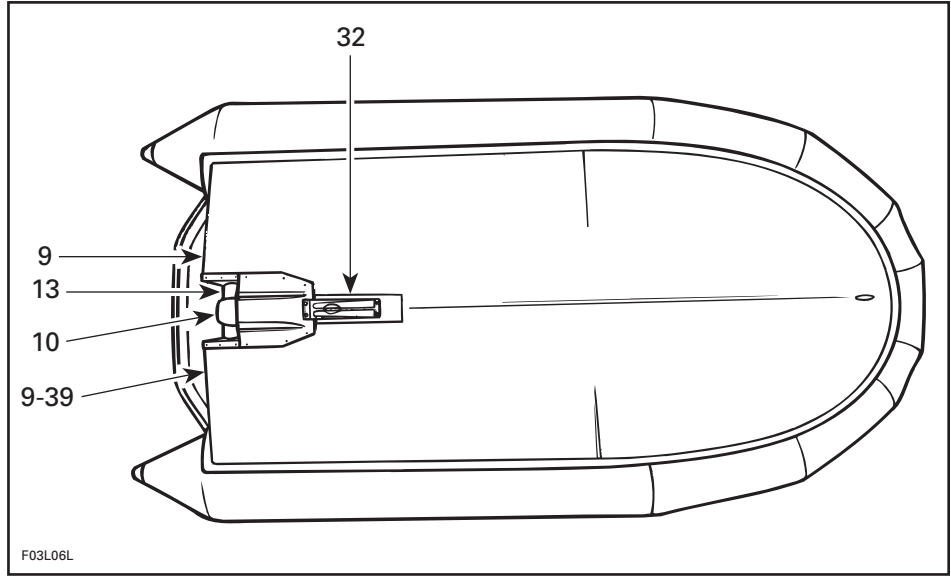

*UNDERNEATH VIEW*

## 1) Safety Lanyard Switch

Attach the safety lanyard to the operator's PFD and snap the cap to the switch to be able to start the engine.

Pulling the safety lanyard from the switch stops the engine operation.

### ◆ WARNING

Should the engine be stopped, boat directional control is not available.

### ▼ CAUTION

Always remove safety lanyard when leaving the boat. Leaving the safety lanyard on switch will eventually drain the battery.

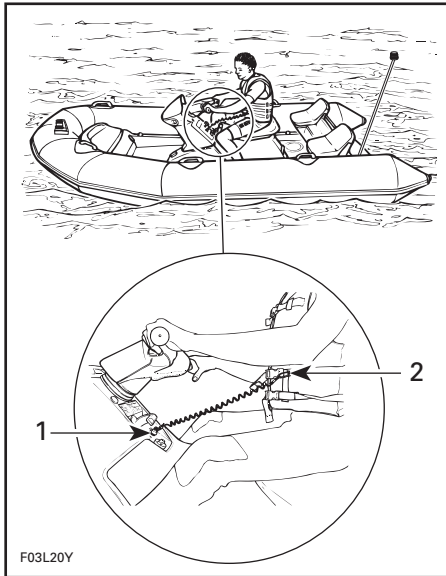

1. Safety lanyard cap on the switch
2. Safety lanyard secured on operator's PFD

## 2) Handlebar

The handlebar controls the direction of the jet boat. Turning the handlebar to the right steers the jet boat to the right and inversely.

### ◆ WARNING

Check handlebar and corresponding steering nozzle operation before starting.

## 3) Throttle Lever

It controls the speed of the engine and therefore, the speed of the boat.

When squeezed, the jet boat accelerates. When fully released, engine automatically returns to idle speed and boat is gradually stopped by water drag.

### ◆ WARNING

Check throttle lever operation before starting the engine.

## 4) Choke Lever

The choke is provided to supply a richer fuel/air mixture when starting a cold engine. When the lever is completely pulled, the choke is fully applied. The use of the choke is not recommended with a warm engine.

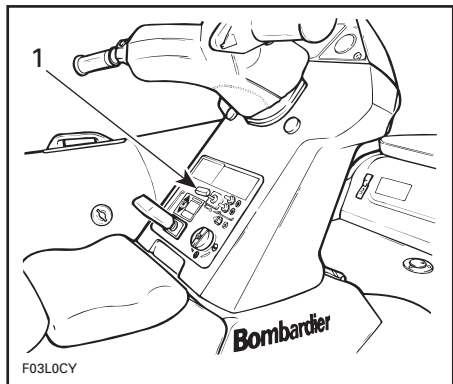

1. Fully pulled

## 5) Light Switch

A 3-position switch.

**NOTE:** The safety lanyard must be snapped to the switch to have navigation lights working.

**ANC:** Turns on the anchorage light when boat is anchored. Only the stern light is lit.

**OFF:** Turns off all lights.

**NAV:** Turns on both bow and stern lights.

## 6) Engine Cover Latch

The engine cover latch is located at the rear end of cover.

To remove engine cover, pull the latch lever upward. With the operator seat integrated handle, lift and pull the engine cover rearward.

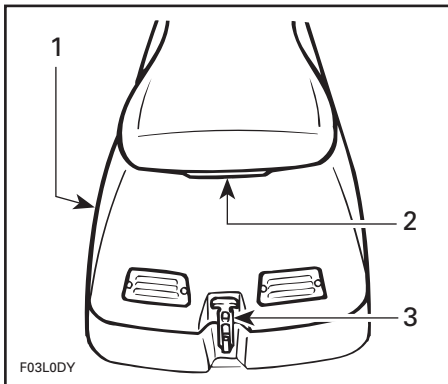

### TYPICAL

1. Engine cover
2. Seat integrated handle
3. Latch

When reinstalling the engine cover, insert engine cover front tab into body hook and install rear latch lever.

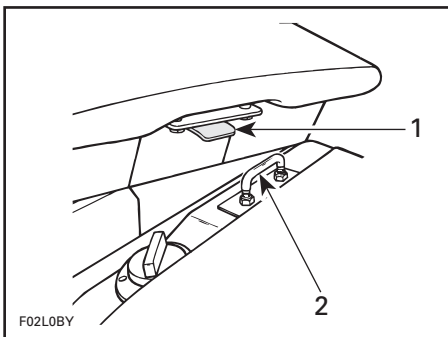

### TYPICAL

1. Insert this tab in hook
2. Hook

## ◆ WARNING

Periodically verify the seat hook upper nuts and lock nuts, tighten if needed. Make sure engine cover is securely latched.

## 7) Boarding Platform

Provides a large surface for easy boarding from rear of jet boat.

## 8) Cooling System Bleed Outlet

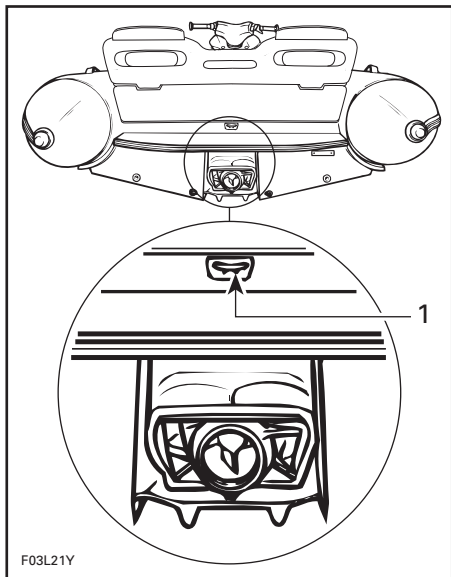

### TYPICAL

1. Bleed outlet

When engine is running, water must flow from this hole. This allows air in engine water jacket to escape. It also indicates that water is circulating in the cooling system.

### ▼ CAUTION

Should water not flow from this outlet a few seconds after engine starts, immediately stop engine and refer to POST-OPERATION CARE and look for cooling system flushing or refer to an authorized dealer for servicing.

## 9) Bilge Drain Plugs

Should water be found in the bilge, it can be easily drained by unscrewing these plugs.

### ▼ CAUTION

Remove boat from water prior to unscrew drain plugs.

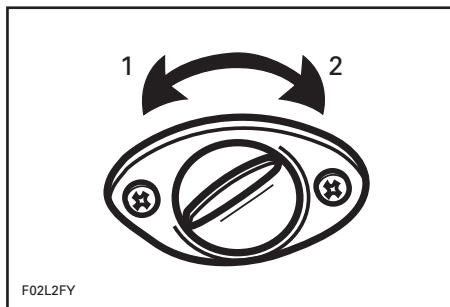

1. Unscrew
2. Tighten

Tilt the boat slightly to the rear so that the water can completely flow out of the bilge.

It is suggested to drain bilge on a ramp.

### ◆ WARNING

Always make sure bilge drain plugs are properly tighten.

## 10) Jet Pump Nozzle

It is turned from side to side via rider input at the handlebar. This provides jet boat directional control when engine is running.

## 11) Air Intake Openings

This is where air enters to supply the engine and ventilate the engine compartment.

## 12) Fuel Tank Cap

Unscrew the cap counterclockwise to allow fuel tank filling. Fully tighten when finished.



### WARNING

Never use a lit match or open flame to check fuel level.

## 13) Reverse Gate

It moves from upward to downward position to get forward, neutral, reverse and inversely. These positions are obtained with the selector lever.



### CAUTION

Never use reverse gate as a supporting point to board the jet boat, it may damage reverse system components.

## 14) Rear Vent Grills

Allows air to get in or out depending on engine operation.

## 15) Stern Eyelet

Eyelet can be used for mooring, towing and as a tie-down point during transportation.

## 16) Deck

It is an antiskid surface. User's feet should rest on the deck when riding.

## 17) Grab Handles

Provides a handhold for the passengers.



### CAUTION

Lever use the grab handles to pull anything or to lift the jet boat.

## 18) Fuel Valve

A 3-position rotating valve, OFF, ON and RESERVE:

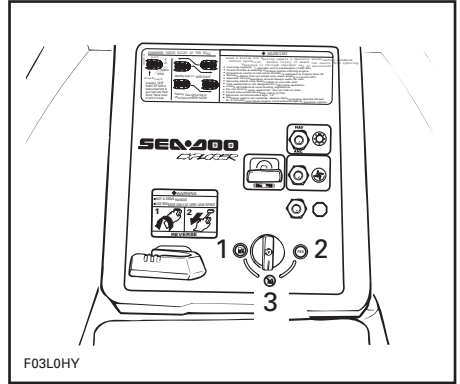

1. ON
2. RES
3. OFF

OFF: Stop fuel supply to carburetors.



### CAUTION

Turn valve to OFF position when boat is not operated.

ON: Allows fuel to flow to carburetors. This is the normal position for boat operation.

RES: Use when the jet boat has run out of fuel in the ON position.



### WARNING

Always refill the fuel tank at the first opportunity. After refueling, turn the fuel valve to the ON position for further operation.

## 19) Selector Lever

When pushed in, the boat is in forward. To obtain neutral, unlock lever by turning it counterclockwise, then pull lever until neutral mark appears on rod. To engage reverse, repeat same procedure as for neutral, but pull lever until reverse mark appears on rod. Lever locks in forward and in neutral positions only.

### ◆ WARNING

Selector lever should only be used when the engine is idling. Engaging the reverse at any other speed may damage reverse system components and possibly cause personal injuries. Ensure lever is pushed in and locked. Do not use as a grab handle.

## 20) Engine Overheating Beeper

In the event the engine overheats, a beeper (continuous sound) will warn the operator. Stop the engine and refer to SPECIAL PROCEDURES.

## 21) Engine Start/Stop Button

Dual function push type switch.

To start engine, depress and hold the button. Release immediately after engine is started.

To stop engine, fully release throttle lever then depress the button.

### ◆ WARNING

When the engine is stopped, jet boat directional control is not available.

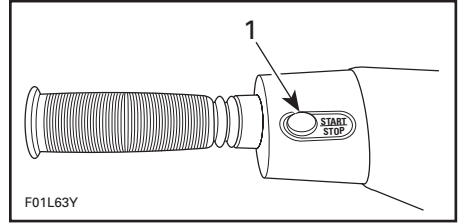

1. Engine START/STOP Button

## 22) Rear Storage Compartment Cover

To access storage compartment, lift both toggle latches and gently lift cover. When completely lifted, the cover stays open with the help of a wire. Push on cover to close it. Secure cover latch after closing.

## 23) Rear Storage Compartment

A convenient watertight, compartment to carry the tool kit, *Operator's Guide* and personal articles. Ideal location for spare spark plugs, tow rope, first aid kit, tube repair kit, foot pump, etc.

### ◆ WARNING

Never leave any heavy or breakable object in the storage compartment.

This area is the preferred location to store an approved extinguisher. The fire extinguisher holder is installed in the top right portion of the compartment. This holder contains tool kit, *Operator's Guide*, *Safety handbook* and it has a compartment to carry personal articles. Fire extinguisher should not be left loose in the storage compartment.

## 24) Tool Kit

Contains tools needed to perform basic jet boat maintenance.

## 25) Navigation Lights

Lights should always be used between sunset and sunrise or when visibility is reduced.



### WARNING

Proceed with caution and reduce speed.

### REMOVABLE STERN LIGHT

It is recommended to keep it in rear storage compartment at all time except when needed.

To remove from storage, pull it out.

Resnap to store again.

#### Installation

- Lift connector cap.
- Insert post in connector hole. Ensure to align hole keyway with post screw head.
- Firmly push downward to engage terminals.
- Push lock ring downward. Turn until locked. It may be necessary to slightly turn it to allow its insertion in the hole.
- Check light operation.

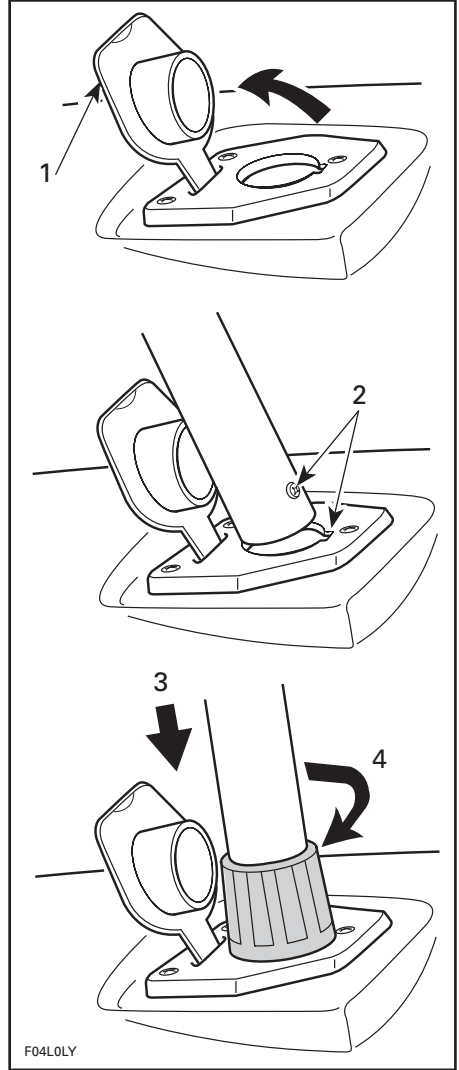

1. Lift
2. Align screw in groove
3. Insert
4. 2° Turn to lock



## 26) Front Storage Cover Latch

Pull the latch lever downward and lift in order to open the storage compartment cover. Always relatch.

## 27) Front Storage Compartment

A convenient watertight compartment to carry fishing seat, anchor, additional PFD, etc.

## 28) Fuel Gauge/Low Oil Warning Light

Located on dashboard, the analog gauge indicates the amount of fuel in the fuel tank and a light turns on when level is low in oil reservoir.

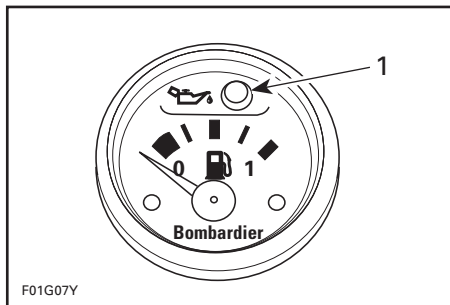

1. Low oil warning light

**NOTE:** To check fuel level when engine is not running, remove safety lanyard and briefly depress engine star/stop button; the gauge will be activated for approximately 30 seconds.

## 29) Oil Injection Reservoir Cap

**NOTE:** Engine cover has to be removed to access oil cap.

Verify oil level through oil reservoir. Unscrew the cap counterclockwise and add appropriate amount of oil.

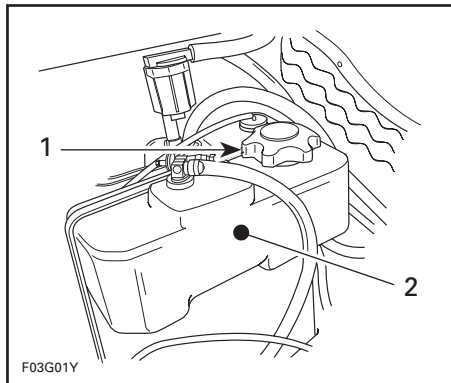

TYPICAL

1. Cap
2. Oil injection reservoir

## 30) Engine Compartment

**NOTE:** Engine cover has to be removed to access engine compartment.

This is where the mechanical, electrical and fuel/oil systems are located.

### ◆ WARNING

When starting or operating the engine, do not touch any electrical part. Never leave any object, rag, tool, etc., in the engine compartment or in the bilge.

## 31) Access Covers

**NOTE:** Covers have to be removed to access bilge. This is where vacuum bailer pick-ups, cooling inlet and outlet, seal carrier and exhaust system are located.

## 32) Jet Pump Water Intake

The water is drawn up by the impeller through this opening. The impeller and the drive shaft are protected by a grate.

### 33) Deck Drain Holes

These 2 holes are located on each side of the deck at the rear. They provide drainage for rain, deck washing or water splashing.

### 34) Bow Eyelet

Eyelet can be used for mooring, towing and as a tie-down point during transportation.

### 35) Deck Eyelets

Eyelets should be used as material tie-down or for lifting the jet boat.

#### ◆ WARNING

Ensure all loose equipment or material is securely tied down on board.

### 36) Inflatable Tube

Inflatable tube is composed of 3 air-tight compartments, separated by partitions, inflated through recessed valves. It is equipped with 6 grab handles.

Refer to maintenance for proper care of the tube.

#### ◆ WARNING

Never inflate tube more than 21 kPa (3 PSI).

### 37) Inflatable Tube Valves

Three valves are installed on the tube, one for each compartment. They are used to inflate or deflate tube as necessary. Refer to maintenance for proper inflation of the tube.

### 38) Air Blower Switch

To start air blower, activate toggle switch. The air blower must be started 4 minutes prior starting the engine.

#### ◆ WARNING

Blower must be turned off during jet boat operation.

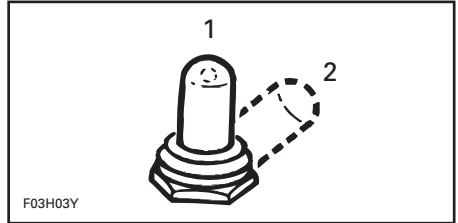

1. OFF
2. ON

### 39) Flushing Connector

Refer to POST-OPERATION CARE section for proper use.

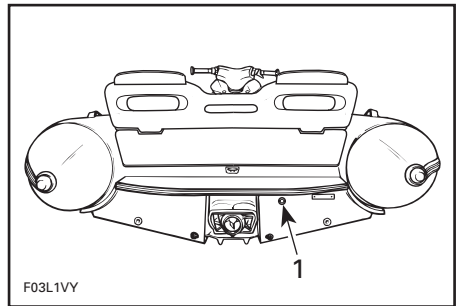

1. Flushing connector

# FUEL AND LUBRICATION

---

## Fueling Procedure

### **WARNING**

Follow these safe boating fueling instructions explicitly.

Make sure the jet boat is tied securely to the fueling pier.

Use bilge blower for a minimum of 4 minutes.

Turn off engine, bilge blower and any other devices that could produce a spark.

Disembark all people.

Do not smoke or allow open flames in the vicinity.

Have a fire extinguisher close at hand.

Do not enter the spout too far in filler neck.

Pour fuel slowly so that air can escape from the reservoir and prevent fuel flowback.

Fill fuel tank to bottom of filler neck. Do not overfill.

Fully tighten fuel tank cap and wipe off any fuel spillage.

Ensure there are no fuel fumes in the engine compartment, ventilate using the blower as necessary.

## Recommended Fuel

Use regular unleaded gasoline with 87 octane ((R + M)/2) specification.

 **NOTE:** Look on service station pump sticker for octane specification. Do not mix oil with fuel except at engine break-in. Refer to BREAK-IN PERIOD. Always check injection oil reservoir level when refueling.

The use of good quality fuel is necessary. A well known fuel brand is highly recommended.

### **CAUTION**

The use of a poor quality fuel can result in jet boat performance deterioration and damage to fuel system and engine components. Never experiment with other fuels or fuel ratios. Never use fuel containing alcohol, methanol or similar products including naphtha.

## Recommended Oil

Use only BOMBARDIER ROTAX INJECTION OIL which is available from authorized dealers. It is a blend of specially selected base oils and additives which provides outstanding lubrication, engine cleanliness and minimum spark plug fouling.

 **NOTE:** High quality low ash API TC injection oil for 2-cycle engines can be used if BOMBARDIER ROTAX INJECTION OIL is not available.

### **CAUTION**

Never use 4-cycle petroleum or synthetic motor oil and never mix these with outboard motor oil. Do not use NMMA TC-W, TC-W2 or TC-W3 outboard motor oils or other ashless type 2-cycle oil. Avoid mixing different brands of API TC oil as resulting chemical reaction may cause severe engine damage.

## Oil Injection System

This jet boat features an oil injection system which does not require manual fuel/oil mixing.

---

Oil level in reservoir should be maintained almost full. To check, remove seat to expose oil reservoir. Verify through oil reservoir. Unscrew cap to add oil as necessary.

Use a flexible funnel to pour oil into reservoir. Wipe off any oil spillage.

**NOTE:** Always carry 500 mL of BOMBARDIER ROTAX INJECTION OIL.



## CAUTION

Always maintain a sufficient amount of injection oil in the oil reservoir. Check and refill every time you refuel. Do not overfill. If the engine runs out of oil, severe engine damage will occur. If the oil reservoir is found almost empty, air can enter in the system and it must be bled. Immediately refer to an authorized dealer to have the oil injection system inspected.

## BREAK-IN PERIOD

---

### Engine

With Bombardier-Rotax® jet boat engines, a break-in period is required before operating the engine at full throttle. Engine manufacturer recommendation is about 10 operating hours.

During this period, maximum throttle should not exceed 3/4, however, brief acceleration and speed variations contribute to a good break-in. Continued wide open throttle accelerations, prolonged cruising speeds and overloading the engine are detrimental during the break-in period.

To assure additional protection during the initial engine break-in, 1L (34 oz) of BOMBARDIER ROTAX INJECTION OIL should be added in the fuel tank for the first full fuel tank filling only.



## CAUTION

Remove and clean spark plugs after engine break-in.

### 10 - Hour Inspection

It is highly recommended that after the first 10 hours of operation, the jet boat be checked by an authorized dealer. This inspection will also provide the opportunity to discuss the unanswered questions you may have encountered during the first hours of operation.

---

The 10-hour inspection is at the expense of the jet boat owner.

---

<b>10-HOUR INSPECTION CHECK LIST</b>	<b>✓</b>
Engine ignition timing (if required)	
Spark plug inspection, cleaning and adjustment	
Fuel system lines and fasteners/pressurization test	
Carburetor adjustment including throttle/choke cables (if required)	
Oil lines and filter	
Oil injection pump adjustment (if required)	
Engine support and engine rubber mounts	
Muffler, battery and reservoir fastening devices	
Exhaust system hose clamp torque	
Carburetor flange nuts and flame arrester bracket	
Steering stem arm torque	
Steering cable adjustment (if required)	
Reverse cable adjustment (if required)	
Cooling system hose condition and fasteners	
Bailer pick-ups, check for obstructions	
Safety lanyard switch	
Engine overheating beeper	
Lighting system	
Electrical connections (starter, battery, etc.)	
RPM limiter operation	
Impeller shaft reservoir oil replacement	
Impeller boot condition, impeller/wear ring clearance	
PTO flywheel lubrication	
Seal carrier lubrication	
Water intake grate/hull condition	
Inspection of fasteners for tightness	
Inspect/clean engine drain tube	
Front and rear storage gasket condition	
Inflatable tube condition	
Sacrificial anode condition	

**We recommend that this inspection chart be signed by an authorized dealer**

\_\_\_\_\_   
 Date of 10-hour inspection

\_\_\_\_\_   
 Authorized dealer signature

# PRE-OPERATION CHECKS

Some of the following items may not have been previously covered in this guide, however they will be described in the MAINTENANCE or SPECIAL PROCEDURES section. Please refer to these portions to have more detailed information.

**Prior to your daily ride, verify the following:**

## ◆ WARNING

Safety lanyard must always be removed from switch prior to verify any of the following.

ITEM	OPERATION	✓
Hull	Inspect.	
Jet pump water intake	Inspect/clean.	
Bilge	Drain. Ensure plugs are secured.	
Battery	Inspect tightness of cables and retaining straps.	
Fuel and oil reservoirs	Refill.	
Engine compartment	Verify for any fuel leak/odor.	
Fire extinguisher	Inspect condition/mounting.	
Steering and throttle systems	Check operation.	
Reverse system	Check operation.	
Inflatable tube	Visually inspect/verify air pressure.	
Safety lanyard, engine start/stop button	Check operation.	

## Hull

Inspect hull for cracks or damage.

## Jet Pump Water Intake

Remove weeds, shells, debris or anything else that could restrict the flow of water and damage cooling system or propulsion unit. Clean as necessary. If any obstruction can not be removed, refer to an authorized dealer for servicing.

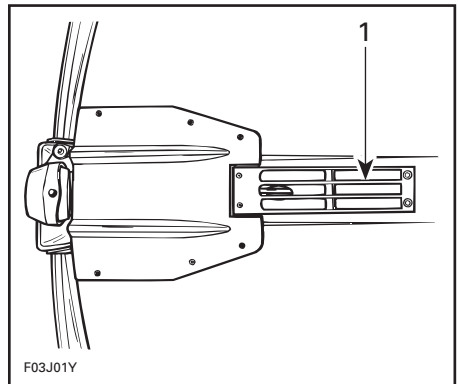

**TYPICAL**  
1. Inspect this area

Inspect leading edges of the impeller, if they have nicks or bends, performance will be greatly reduced.

## Bilge

Should water be present in the bilge, have the jet boat tilted to the rear and unscrew drain plugs to completely empty the bilge.

### ◆ WARNING

Make sure to take the jet boat out of water prior to unscrew the drain plugs.

Reinstall bilge drain plugs.

## Battery

### ◆ WARNING

Verify tightness of battery cables and retaining straps.

## Fuel and Oil Reservoirs

With the jet boat horizontal, fill the fuel tank to specified level with fuel.

Check the oil level and refill reservoir as necessary.

## Engine Compartment

### ◆ WARNING

Should any leak or gasoline odors be present, do not start the engine or operate the jet boat. Immediately refer to an authorized dealer.

## Fire Extinguisher

Make sure it is full, in good condition and well secured.

## Steering and Throttle Systems

Assisted by another person, check steering operation for free movement. When the handlebar is horizontal, the jet pump nozzle should be in the straight ahead position. Ensure the jet pump nozzle pivots easily while handlebar is turned.

Check throttle lever several times for free and smooth operation. It must return to its initial position immediately after released.

## Reverse System

Check reverse gate operation for free movement. With the selector lever pushed in and locked, the gate should be in upward position. Ensure the reverse gate moves easily while selector lever is pulled out.

### ◆ WARNING

Verify the reverse gate locking operation before starting the engine.

## Safety Lanyard and Engine Start/Stop Button

Ensure that both switches operate properly. Start engine and stop it using each switch individually.

### ◆ WARNING

If engine does not shut-off when pushing engine start/stop button or by disconnecting the safety lanyard, stop the engine by applying the choke and turning fuel valve to OFF position. Do not operate the boat further, see an authorized dealer.

---

## Inflatable Tube

Inspect tube for scratches and/or damage. Verify air pressure using valve adapter and pressure gauge. The air pressure should always be at 21 kPa (3 PSI).

○ **NOTE:** The valve adapter is part of the tube repair kit. A low pressure gauge can be used.



### CAUTION

An incorrect pressure will reduce the tube service life.



### WARNING

Never inflate tube more than 21 kPa (3 PSI). Inflating tube more than specified pressure may damage tube and cause personal injury. Never use high pressure to inflate tube.

## Clothing



### WARNING

Always wear a Coast Guard approved PFD.

It is also recommended that gloves, wet suit, deck shoes/booties and protective glasses be worn when operating the boat.



# OPERATING INSTRUCTIONS

## ◆ WARNING

Always perform the PRE-OPERATION CHECKS before operating the jet boat. Become thoroughly familiar with all controls and the function of each. Should any control or instruction be not fully understood, refer to an authorized dealer.

## Principle of Operation

### Propulsion

The engine is directly coupled to a drive shaft which, in turn, rotates an impeller. This impeller is accurately adjusted in a housing where the water is drawn up from underneath the jet boat. Then the water flows through the impeller to a venturi. The venturi accelerates the water and produces thrust to move the jet boat. Depressing the throttle lever increases engine speed and therefore jet boat speed.

The selector lever is used for either driving the jet boat forward or backward. With lever pushed in, the watercraft is in forward position, with the lever fully pulled out reverse position is obtained. The lever middle position is neutral. These 3 functions are produced by the mean of a gate, which is installed on jet pump venturi housing. This gate directs the water flow to get the proper function.

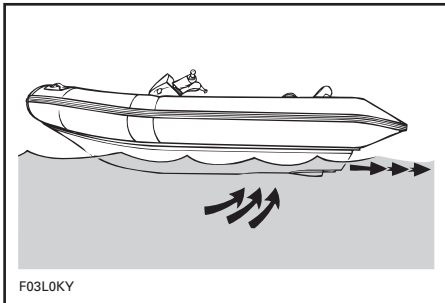

## ◆ WARNING

Whenever the engine is to be started, the operator should always be sitting on the jet boat with the selector lever in neutral position. Selector lever should only be used when the engine is **idling**. Engaging the reverse at any other speed may damage reverse system components and possibly cause personal injuries. Ensure lever is pushed in and locked.

### Turning

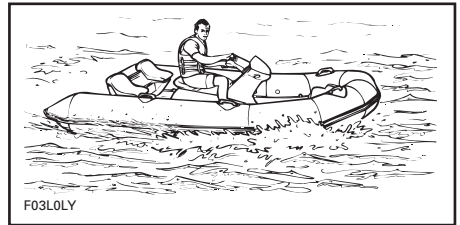

### TYPICAL

Turning the handlebar pivots the jet pump nozzle which controls the jet boat direction. Turning the handlebar to the right will turn the jet boat to the right and inversely. The throttle must be applied to turn the jet boat.

## ◆ WARNING

Directional control is lost when the throttle is released. Throttle must be applied and handlebar turned to change the direction of the jet boat. Steering efficiency will differ depending on number of passengers, load and water condition.

The more the throttle is applied while turning the handlebar, the sharper the turn will be.

The jet boat behaves differently with passengers and requires greater skill. The passengers should always grip the grab handles. Reduce speed and avoid sharp turns. Avoid choppy water conditions when carrying passengers.

## Boarding from a Dock or in Shallow Water

As with any craft, getting aboard should be done carefully.

When boarding from a dock, slowly place one foot on the jet boat deck nearest the dock and then move the other foot over inflatable tube. Never use the inflatable tube as a boarding support. Push the jet boat away from the dock.

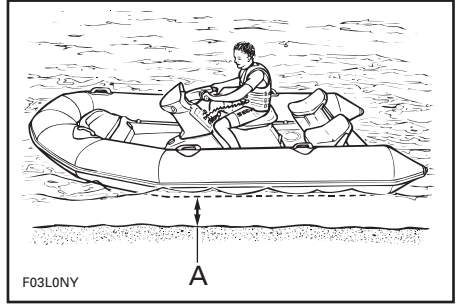

*TYPICAL*

A. 90 cm (3 ft)

In shallow water, board the jet boat either from the side or the rear.

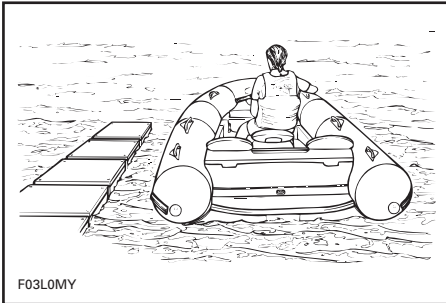

*TYPICAL*

### ▼ CAUTION

The engine should be started with at least 90 cm (3 ft) of water below the hull.

### ◆ WARNING

An inexperienced operator should practice how to get aboard close to the shore to simulate deep water boarding. Refer to **Boarding in Deep Water** in this section.

## Starting the Engine

Before unloading the jet boat from the trailer, it can be started for about 10 seconds to verify proper operation.

### ◆ WARNING

Do not touch electrical parts or jet pump area when engine is running.

Always activate air blower 4 minutes before starting the engine.

### ◆ WARNING

Blower must be turned off during jet boat operation.

Attach the safety lanyard to the operator's PFD and snap the cap to the switch.

## Cold Engine

### ◆ WARNING

Operator and passengers should be sitting on seats prior to starting the engine.

Turn the fuel valve to ON position.

Firmly grip handlebar with your left hand and place both feet on the floorboard. Turn off air blower switch.

Fully pull the choke lever with your right hand and depress the engine start/stop button.

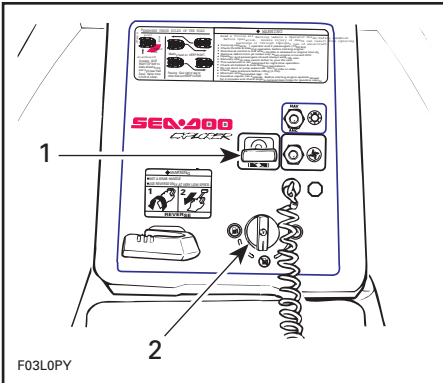

1. Fully pull
2. Turn to ON

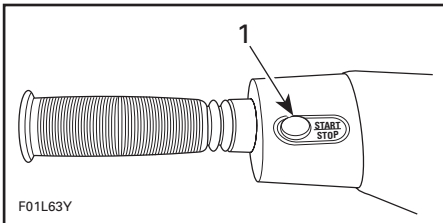

1. Press

Immediately after engine is started, release start/stop button and release choke lever half way.

○ NOTE: Do not depress the throttle lever while starting a cold engine.

### ▼ CAUTION

To avoid starter motor overheating, the cranking period should not exceed 5-10 seconds and a rest period should be observed between cranking cycles to let the starter cool down and its mechanism disengage.

A few seconds after, completely release the choke lever and, if necessary, slightly apply throttle to keep engine running.

Slowly accelerate to reach deeper water. Do not apply full throttle until the engine is warm.

### ◆ WARNING

In shallow water, shells, sand, pebbles or other objects could be drawn up by the jet pump and damage impeller, components or clog the cooling system. Also, debris could be thrown rearward into bystanders.

## Warm Engine

The same procedure as a cold engine applies, except the choke does not need to be applied and throttle lever has to be slightly depressed.

## Obstacles

Verify that the path ahead of the jet boat is clear of other craft or obstacles. Avoid riding close to swimmers. Check local boating laws for safe operation.



## WARNING

Only start the jet boat once all items have been checked and operate properly.

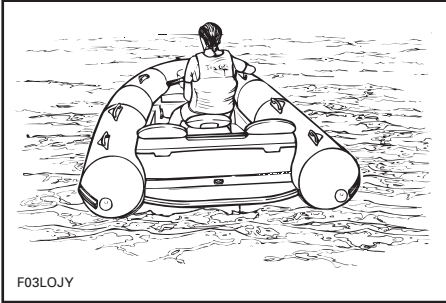

F03LOJY

TYPICAL

## Boarding in Deep Water



## WARNING

Inexperienced riders should practice how to get aboard close to shore first before venturing into deep water.

### Operator Alone

Swim to the rear of the jet boat.

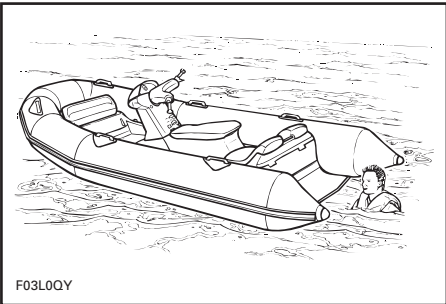

F03LOQY

TYPICAL

Grip the grab handle and pull yourself upward until your knee can reach the platform.



## CAUTION

Never use reverse gate as a supporting point to board the jet boat, it may damage reverse system components.

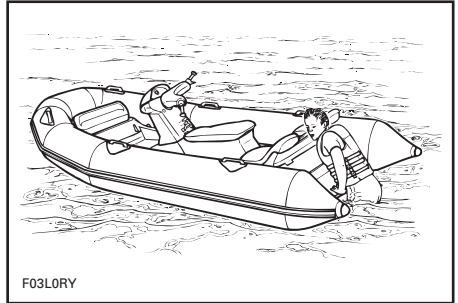

F03LORY

TYPICAL

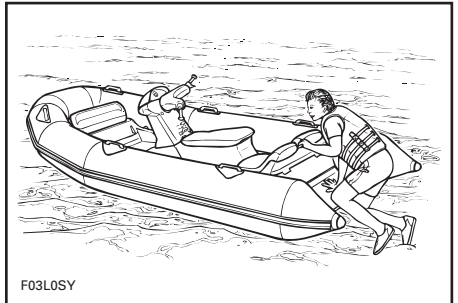

F03LOSY

TYPICAL

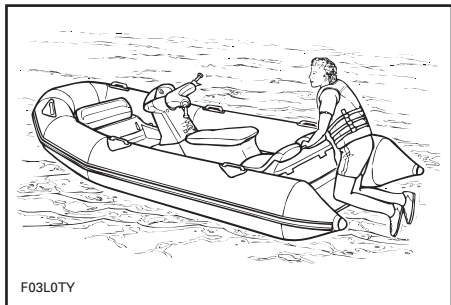

TYPICAL

Always activate air blower 4 minutes before starting the engine.

Attach the safety lanyard to the operator's PFD and snap the cap to the switch.

Turn off air blower switch.

Start the engine.

### Operator with Passengers

The operator climbs on the jet boat the same way as explained previously.

The passenger then climbs on the jet boat while the operator may help him in climbing aboard.

### ◆ WARNING

It is not recommended to climb aboard from tube area using grab handle.

Always activate air blower 4 minutes before starting the engine.

Attach the safety lanyard cap to the switch.

Turn off air blower switch.

### ◆ WARNING

Do not start engine until the passengers are properly seated.

## Rough Water Operation

Avoid operation in these conditions. If you must do so, proceed with caution using minimum speed.

## Crossing Waves/Wakes

Reduce speed and cross the wave at an angle.

Always be prepared to steer and balance as necessary.

When crossing wakes, always keep a safe distance of boat ahead.

### ◆ WARNING

When crossing waves, operator and passenger(s) should always brace themselves by posting. Do not jump or cross wakes or waves at speed.

## Stopping/Docking

The jet boat is slowed by water drag. The stopping distance will vary depending on weight, water surface condition, presence and direction of wind and current.

The operator should familiarize himself with the stopping distance under different conditions.

Release the throttle at a sufficient distance of the expected landing area, water resistance will slow down the jet boat.

Reduce speed when approaching a dock then shut off the engine just before coming alongside.

### ◆ WARNING

No directional control is available when the throttle is closed or engine is shut off. Never use the reverse system for stopping the jet boat.

## Beaching

### ▼ CAUTION

It is not recommended to run the jet boat to the beach.

Proceed the same way as for docking except for the following:

Come slowly to the beach and shut off the engine when reaching about 90 cm (3 ft) of water under the hull.

### ▼ CAUTION

Avoid docking or beaching where sharp objects are present. Tube perforation may occur.

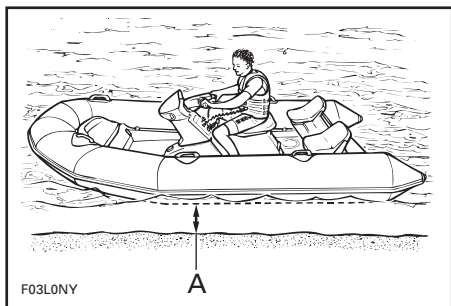

TYPICAL

A. 90 cm (3ft) of water under the hull

### ▼ CAUTION

In shallow water, shells, sand, pebbles or other objects could be drawn up by the jet pump and damage impeller, components or clog cooling system.

Get off jet boat and pull it on the beach.

## Shutting Off the Engine

To keep jet boat directional control, the engine should be running until the jet boat is stopped assuming at least 90 cm (3 ft) of water is present underneath the hull.

To shut off the engine, completely release throttle lever and press the engine start/stop button.

Remove safety lanyard from jet boat.

### ◆ WARNING

Should the engine be shut off, jet boat directional control is not available. Never leave the safety lanyard on an unattended watercraft.

## Night Time Operation

### ◆ WARNING

Proceed with caution and reduce your speed.

Be extremely cautious when operating at night.

All day time hazards exist but are hidden by darkness.

The boat is not equipped with head or search lights.

# POST-OPERATION CARE

## General Care

Should any water be present in the hull, unscrew the drain plugs and tilt the jet boat to the rear in order to allow water to flow out.

Wipe up any remaining liquid in the engine compartment (bilge, engine, battery, etc.) with clean dry rags (this is particularly important in salt water use).

Remove the jet boat from the water every day to prevent marine organisms growth.

Leave the engine cover partially opened. This will avoid engine compartment condensation and possible corrosion.

**NOTE:** When the jet boat is stored with engine cover partially opened and without a tarpaulin, unscrew the drain plugs in order to avoid water build up in the bilge during rainfall.

## Additional Care for Foul Water or Salt Water

When the jet boat is operated in foul water and particularly in salt water, additional care must be taken to protect the jet boat and its components. Rinse bilge area with fresh water.

### CAUTION

Failure to perform proper care such as: jet boat rinsing, cooling system flushing and anticorrosion treatment, when jet boat is used in salt water, will result in damage to the jet boat and its components.

## Cooling System Flushing and Engine Internal Lubrication

Flushing the cooling system with fresh water is essential to neutralize corroding effects of salt or other chemical products present in water. It will help to clean up sand, salt, shells or other particles in water jackets (engine, exhaust manifold, tuned pipe) and/or hoses.

Engine lubrication and flushing should be performed when the jet boat is not expected to be used further the same day or when it is stored for any extended time.

Proceed as follows:

### WARNING

Perform this operation in a well ventilated area.

1. Clean jet pump by spraying water in its inlet and outlet and then SEA-DOO LUBE lubricant.

**NOTE:** A quick connect hose adapter can be fixed to ease garden hose installation to boat's connector.

2. Connect a garden hose directly to the flushing connector. To prevent water leak, ensure the rubber washer is in the boat's connector. Do not open water tap yet.

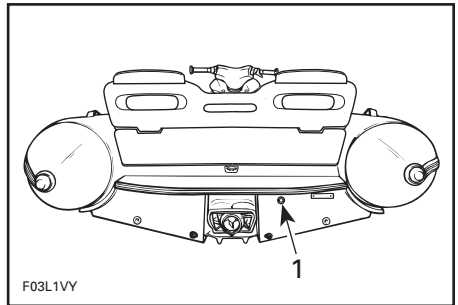

1. Flushing connector

3. Start the engine then immediately open the water tap.



## WARNING

Do not touch any electrical part or jet pump area when engine is running.



## CAUTION

Never flush a hot engine. Always start the engine before opening the water tap. Otherwise, water will back flow through the tuned pipe into the engine and may cause damage to internal parts. Open water tap immediately after engine is started to prevent overheating.

4. Run the engine about 3 minutes at a fast idle around 3500 RPM.



## CAUTION

Never run engine longer than 5 minutes. Drive line seal has no cooling when jet boat is out of water.

5. Pull plug from air intake silencer cover.
6. Spray SEA-DOO LUBE lubricant through air intake silencer cover keeping engine at fast idle.

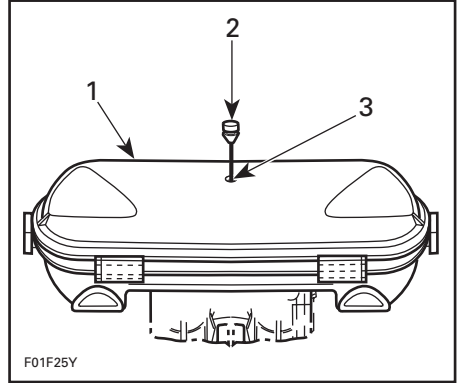

1. Air intake silencer cover
2. Pull plug
3. Spray SEA-DOO Lube here

**NOTE:** Lubrication of engine should be done at least for 1 minute. After approximately half a minute, close fuel valve to run engine out of fuel while lubricating.



## CAUTION

When engine begins to run irregularly because of fuel starvation, immediately stop water flow before engine dies. Severe engine damage could result if not done in this order.

7. Close the water tap then stop the engine.



## CAUTION

Always close the water tap before stopping the engine, otherwise severe engine damage could occur.

8. Disconnect the garden hose. Ensure the rubber washer remains in boat's connector.
9. Wipe up any residual water from the engine.



10. Remove spark plug cables and connect them on the grounding device.

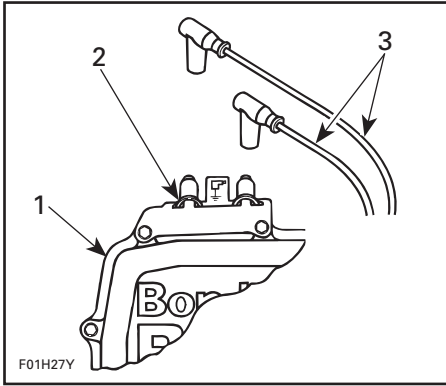

1. Magneto housing cover
2. Grounding device
3. Spark plug cables

11. Remove both spark plugs and spray SEA-DOO LUBE lubricant into each cylinder.
12. Crank the engine a few turns to distribute the oil onto cylinder wall.
13. Apply antiseize lubricant on spark plug threads then reinstall them.
14. Reinstall plug on air intake silencer cover.

## Anticorrosion Treatment

To prevent corrosion, spray a corrosion inhibitor (salt water resistant) such as SEA-DOO LUBE lubricant or equivalent over metallic components in engine compartment.

**NOTE:** Engine fogging should be done with SEA-DOO LUBE lubricant whenever the jet boat is to be stored for few days or a long period.

Apply dielectric grease (salt water resistant) on battery posts and cable connectors.

## CAUTION

Never leave rags or tools in the engine compartment or in the bilge.

# SPECIAL PROCEDURES

---

## Engine Overheat

If the engine overheating beeper sounds continuously, **stop engine immediately.**

Perform the **Jet Pump Water Intake and Impeller Cleaning** procedure in this section.

Flush cooling system, refer to POST-OPERATION CARE.

If engine still overheats, refer to an authorized dealer for servicing.

## Jet Pump Water Intake and Impeller Cleaning

Weeds, shells or debris can get caught on the intake grate, drive shaft and/or impeller. A clogged water intake may cause troubles such as:

- 1- **Cavitation:** Engine speed is high but jet boat moves slowly due to reduced jet thrust; jet pump components may be damaged.
- 2- **Overheating:** Since the jet pump operation controls the flow of water to cool the engine, a clogged intake will cause the engine to overheat and damage engine internal components.

The clogged area can be cleaned as follows:

Shut off the engine and let the boat stop by itself then wait approximately 10 seconds before restarting engine. This waiting period may allow weeds to fall free from grate.



## WARNING

When the engine is shut off, jet boat directional control is not available.

If system is still clogged, proceed with following procedure:

With the engine running, put selector lever in reverse position and vary throttle quickly several times.

Retry boat.

If still clogged, restop boat and rock several times while repeatedly pressing start/stop button for short period without starting engine.

If the jet pump can not be cleared of debris, the jet boat should be returned to the trailer or to a boat lift.

Clean the water intake area. If the system is still clogged, refer to an authorized dealer for servicing.



## CAUTION

Avoid jet boat operation in weed areas. If unavoidable, vary jet boat speed. Weeds tend to entangle more at steady speed and at slow speed. Inspect water intake grate for damage. Refer to an authorized dealer for repair as necessary.

## Capsized Boat

The jet boat is designed so that it should not turn over easily, due to its longer and larger dimensions and its inflated tubes. If it turns over, it will remain capsized. To return the jet boat upright proceed as follows:

- Deflate the right tube (seen from rear)
- Rotate jet boat **clockwise** (seen from rear) by pushing on the right side

- Handhold the **side of water intake hole** and use your weight to complete the jet boat rotation.

**◆ WARNING**

**In the event it is impossible to upright the boat, remain with it, you will be more easily located by a search plane or boat.**

### Submerged Boat

If the jet boat is submerged and engine is water-flooded, it is strongly recommended that the jet boat be serviced by an authorized dealer immediately.

In the event the engine cannot be serviced within a few hours, remove spark plug cables and connect them on the grounding device.

**◆ WARNING**

**Never crank engine with spark plugs removed unless spark plug cables are connected to the grounding device.**

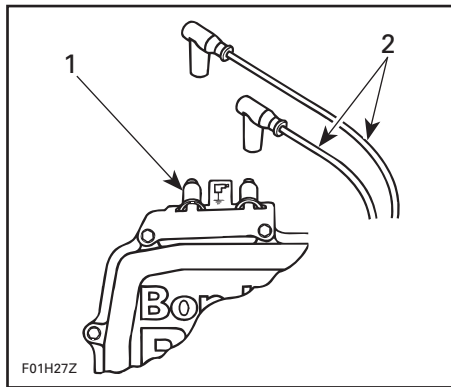

1. Grounding device
2. Spark plug cables

Remove spark plugs and dry them with a clean cloth.

Cover spark plug holes with a rag.

Crank engine to allow water to escape from spark plug holes.

Spray SEA-DOO LUBE lubricant into spark plug holes.

Crank engine again.

Reinstall spark plugs.

### Towing the Boat

In the event the jet boat becomes inoperative, tie a tow rope to the bow (front) eyelet. However, special precautions should be taken.

The maximum recommended towing speed is 24 km/h (15 MPH).

When towing your boat, pinch the water supply hose from the impeller housing to the engine with a hose pincher (not supplied) (P/N 529 030 400) shown in the following illustration.

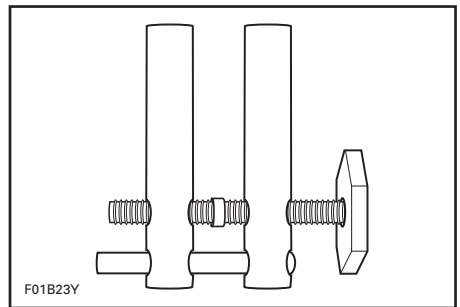

This will prevent the cooling system from filling which may lead to water being injected into and filling the exhaust system. Without the engine running there isn't any exhaust pressure to carry the water out the exhaust outlet.

**▼ CAUTION**

Failure to do this may result in damage to the engine. If you must tow a stranded boat and do not have a hose pincher be sure to stay well below the maximum towing speed of 24 km/h (15 MPH).

Snugly install the hose pincher on the hose as shown in the following illustration.

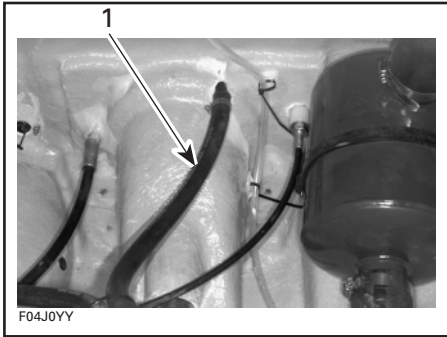

TYPICAL

1. Install hose pincher on this hose

**▼ CAUTION**

When finished towing the boat, you must remove the hose pincher before operating it. Failure to do so will result in damage to the engine.

**Low-Charge Battery Condition**

See your dealer to have it charged or replaced.

**◆ WARNING**

Do not charge or boost the battery in the jet boat. Connecting cables could produce a spark and possibly cause an explosion if fuel or electrolyte vapors are present.

# MAINTENANCE

## ◆ WARNING

Only perform procedures as detailed in this guide. It is recommended that the assistance of an authorized dealer be periodically obtained on other components/systems not covered in this guide. Unless otherwise specified, engine must not be running and the safety lanyard must be removed for all maintenance procedures.

○ NOTE: Servicing period is given in hours.

## Lubrication

### PTO Flywheel and Seal Carrier

Use SEA-DOO synthetic grease and lubricate every 10 hours. Proceed as follows:

Remove engine cover to access engine compartment.

Remove the wing nuts, washers and pull out PTO flywheel guard.

## ◆ WARNING

Always remove safety lanyard cap from its receptacle to prevent accidental engine starting before removing the PTO flywheel guard.

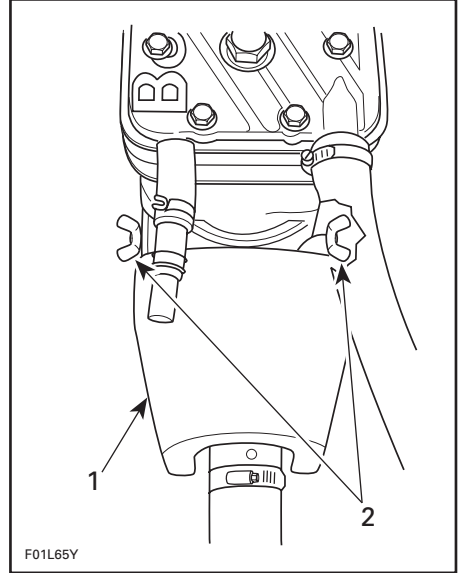

### TYPICAL

1. Flywheel guard
2. Wing nuts

Using a grease gun, carefully lubricate PTO flywheel at grease fitting until drive shaft boot is just beginning to expand.

## ▼ CAUTION

Immediately stop lubricating as soon as boot begins to expand to prevent boot damage or slipping.

Lubricate seal carrier at grease fitting until grease is just coming out.

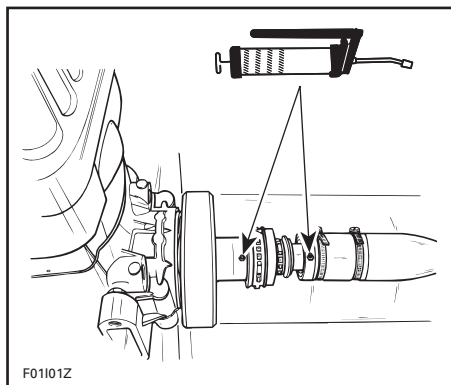

## Choke Lever

Fully pull choke lever and lubricate the metallic portion.

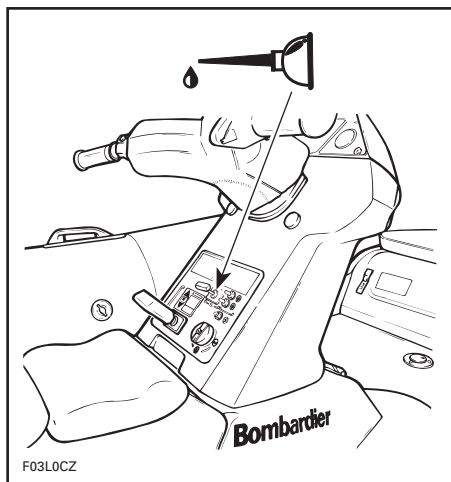

## ▼ CAUTION

As soon as grease comes out the seal immediately stop lubricating. Never leave any clothing, tool or other objects near PTO fly-wheel and seal carrier.

Secure PTO flywheel guard.

## Anticorrosion Protection

### Throttle/Choke Cables

Lubricate the throttle and choke cables with SEA-DOO LUBE lubricant every 25 hours and every 10 hours in salt water use.

### Electrical Connections

As necessary, apply anticorrosion product such as a dielectric grease on battery posts and all exposed cable connectors.

## Additional Lubrication

SEA-DOO LUBE lubricant will help to prevent corrosion and keep proper operation of moving mechanisms.

Lubrication of the following items should be performed every 50 hours in fresh water use but every 10 hours in salt water use.

## Engine Cover Attachment, Tab and Hook

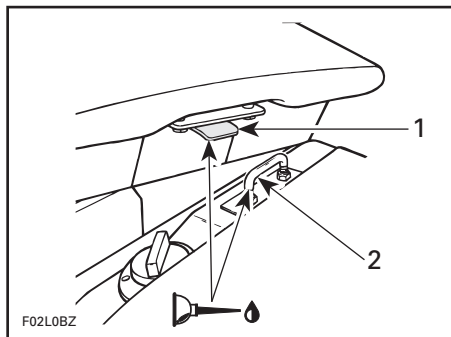

### TYPICAL

1. Tab
2. Hook

## Carburetors and Oil Injection Pump

Lubricate springs, shafts and exposed portion of cables.

○ NOTE: Grease carburetor linkage at both ends with synthetic grease.

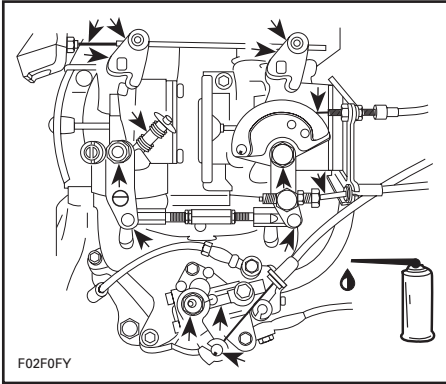

*TYPICAL*

### **Reverse System**

Lubricate support plate sliding area of sliding block, triangular lever, sliding washer and selector lever stem with synthetic grease.

### **Periodic Inspection**

Routine maintenance is necessary for all mechanized products. A periodic inspection contributes to the products life span.

The following maintenance chart gives guidelines for regular jet boat servicing schedule to be performed by you and/or by an authorized dealer. The schedule can be adjusted according to operating conditions and use.

## Periodic Inspection Chart

DESCRIPTION	FREQUENCY				
	Every 10 hours	Every 25 hours	Every 50 hours	Every 100 hours or seasonally	To be performed by
Lubrication/Corrosion Protection	①		✓		OPERATOR
Engine Ignition Timing				✓	DEALER
Spark Plug Replacement			✓		DEALER
Throttle/Choke Cables, Inspection/Lubrication	①	✓			OPERATOR
Flame Arrester Inspection			✓		DEALER
Carburetor Adjustment Including Choke/Throttle Cable Adjustments and Linkage				✓	DEALER
Oil Injection Pump Adjustment				✓	DEALER
Fuel Filter and Oil Filter Inspection		✓			DEALER
Oil Filter and Fuel Filter Replacement				✓	DEALER
Engine Head Screws, Retorque				✓	DEALER
Steering System			✓		DEALER
Reverse System/Reverse Cable Adjustment				✓	DEALER
Fastener Tightening (Flame Arrester Mount Screws, Carburetor Mount Nuts, Engine Mount Screws, Exhaust System, etc.)			✓		DEALER
Muffler, Battery and Reservoir Fastening Devices			✓		OPERATOR
Fuel/Oil Line, Check Valve and Hose Inspection, Fuel System Pressurization			✓		DEALER
Inspect/Clean Engine Drain Tube	①	✓			DEALER
Bilge System/Deck Drain Holes, Inspection			✓		OPERATOR
Battery Condition			✓		DEALER
Battery and Starter Cables		✓			DEALER
Engine Overheating Beeper/Electrical Connections			✓		DEALER
Impeller Shaft Reservoir Oil Level/Oil Condition		✓		Replace	DEALER
Impeller Condition and Impeller/Wear Ring Clearance		②	✓		DEALER
Drive Shaft Boot and Spline Condition (Both Ends)		②	✓		DEALER
Pto Flywheel Lubrication	✓				OPERATOR
Seal Carrier Lubrication	✓				OPERATOR
Water Intake Grate Condition		②	✓		DEALER
Hull Condition				✓	DEALER
Cooling System Flushing ③		✓			OPERATOR
Lights Condition		✓			DEALER
Inflatable Tube Condition		✓		④	DEALER
Zinc Anode			✓		OPERATOR
Air Blower Inspection			✓		DEALER

**NOTE:** Some items are included in the PRE-OPERATION CHECKS and are not necessarily repeated in this chart.

- ① Every 10 hours in salt water use.
- ② These items have to be initially checked after 25 hours. Thereafter, servicing to be made as specified in this chart.
- ③ Daily flushing in salt water or foul water use.
- ④ Inflatable tube should be removed and cleaned. Also verify tube attachment condition.



## Throttle and Choke Cable Inspection

### Throttle Cable

Depress and release the throttle lever several times. It must operate smoothly and return to its initial position without any hesitation. Refer to an authorized dealer if necessary.

#### ◆ WARNING

If throttle lever does not automatically return, do not operate jet boat and see your dealer.

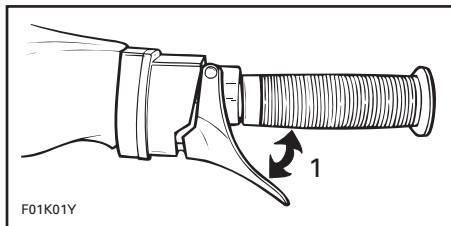

1. Must move freely

### Choke Cable Inspection

Ensure it operates smoothly and without any hesitation from fully open to fully close. When the choke lever is fully pulled, choke must be fully applied. Refer to an authorized dealer if necessary.

### Carburetor Adjustment

Carburetor adjustment is very important to allow good engine operation and therefore jet boat performance. Carburetor adjustment requires technical knowledge and experience to have the correct mixture supplied to the engine. This critical adjustment must be performed by an authorized dealer once a year or more often if necessary.

#### ▼ CAUTION

Serious engine damage can occur with improper carburetor adjustment.

### Fuel and Oil Filters

These filters should be replaced by an authorized dealer annually. Fuel system pressurization should be conducted at the same time.

#### ▼ CAUTION

An obstructed oil filter will cause oil starvation resulting in serious engine damage.

### Steering Alignment

When the handlebar is aimed in straight ahead position, the jet pump nozzle should be in the same direction allowing the jet boat to run in a straight line.

Refer to an authorized dealer if an adjustment is necessary.

#### ◆ WARNING

Ensure the handlebar/jet pump nozzle operate freely from side to side and are not stressing the steering cable and/or bracket.

Steering system wear should be inspected every 50 hours by an authorized dealer.

## Reverse Gate Adjustment

When selector lever is pushed in and locked, reverse gate should be in upward position. With the lever half way out and locked, reverse gate should be in middle position. When lever is fully pulled out, reverse gate should be in downward position. Refer to an authorized dealer if adjustment is necessary.



### WARNING

Ensure the selector lever/reverse gate operate freely and are not stressing the reverse cable. Always make sure selector lever locks in forward.

## Vacuum Bailer Pick-Ups and Deck Drain Holes

### Vacuum Bailer Pick-Ups

Remove access covers. Bailers are located each side of the drive shaft tunnel.

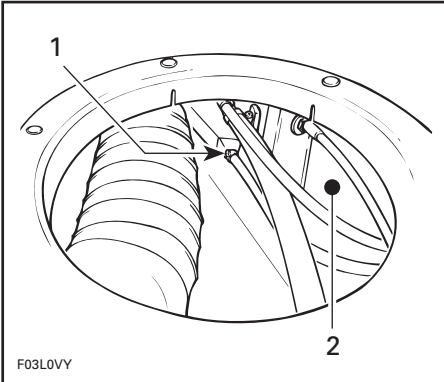

1. Vacuum bailer pick-up
2. Drive shaft tunnel

This jet boat features a vacuum activated syphon. Two pick-ups use a low pressure area in the jet pump to syphon the water out of the bilge.

Inspect each pick-up screen for obstructions, clean as necessary.

Make sure hose routing is not changed.

### Deck Drain Holes

Remove any possible obstructions at drain inlets and outlets.

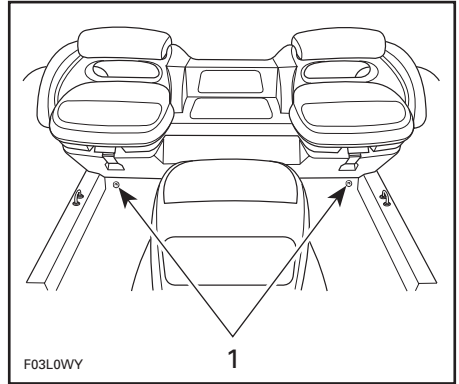

1. Deck drain inlets

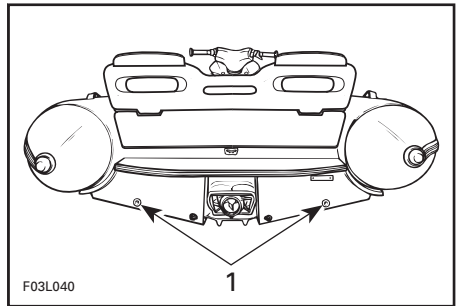

1. Deck drain outlets

## Fuses

Electrical system is protected with 4 fuses. One fuse protects the charging circuit, the second fuse protects the accessories and controls. If starter does not operate or if battery is regularly discharged, check fuse condition.

The lighting system and blower are protected with 2 fuses. If one of the system doesn't work, check fuse condition.

The fuse caps are in the electrical box located on port side (left) and hold spare fuses.

To access fuse caps unclip electrical box from its seat.

Bring it over magneto housing and remove cover.

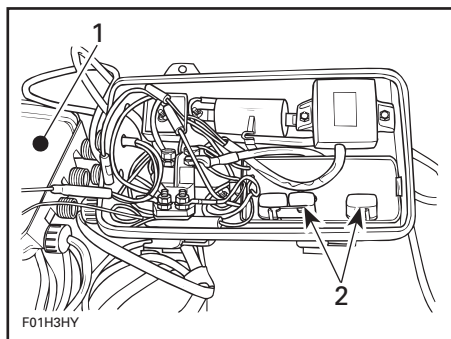

**TYPICAL**

1. Remove cover
2. Fuse caps

Replace the fuse by one of the same rating. Make sure to properly close the fuse cap.

**CAUTION**

Do not use a higher rated fuse as this can cause severe damage. Refer to SPECIFICATIONS section for recommended fuse rating.

Wires in electrical box cover must hang freely. Do not pack wires in cover.

**WARNING**

If any water is found in the electrical box, immediately refer to an authorized dealer before operating the jet boat.

Properly close electrical box cover making sure its seal is well positioned.

Replace electrical box in its support.

**Air Blower**

Verify air blower for proper operation.

**WARNING**

If air blower does not operate properly, immediately refer to an authorized dealer before operating the jet boat.

**Zinc Anode**

This is a sacrifice anode to help reduce propulsion system corrosion in salt water use. Zinc anode is located on ride shoe. Verify anode. Replace it as necessary.

**Light Bulb Replacement  
Bow Light**

Remove screw.

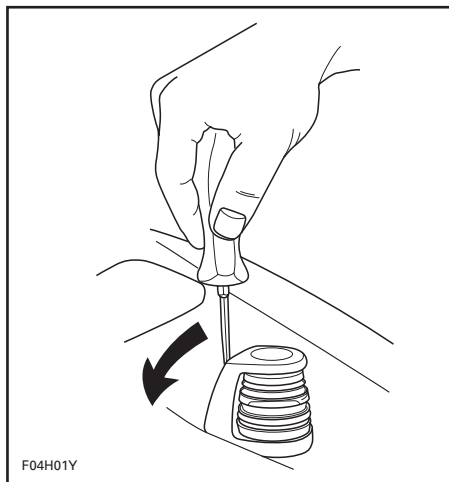

**TYPICAL**

Pull out cover.

Turn lens counterclockwise and pull it out.

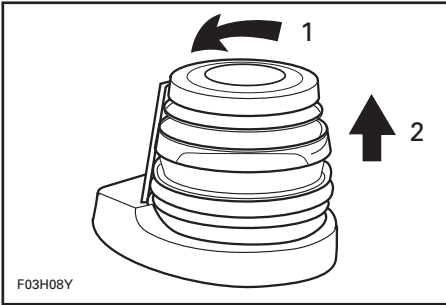

Push and turn bulb counterclockwise to remove it.

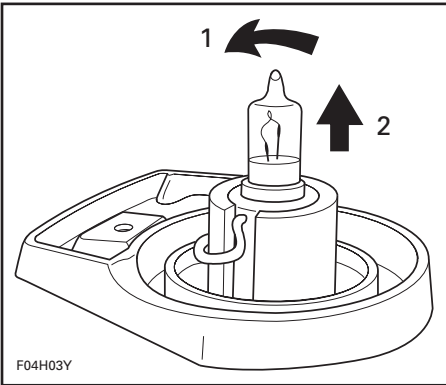

The assembly is essentially the reverse of removal procedures. However, pay particular attention to the following:

Apply dielectric grease on bulb contact surface.

**▼ CAUTION**

Avoid finger contact or grease on bulb.

Properly position lens: green on starboard side, red on port side.

### Stern Light

Turn lens a quarter turn counterclockwise and pull it out.

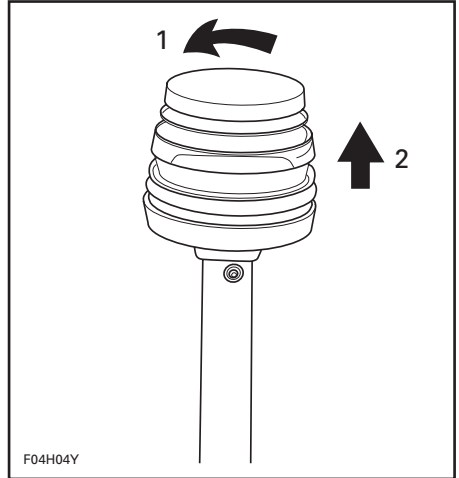

Push and turn bulb counterclockwise to remove it.

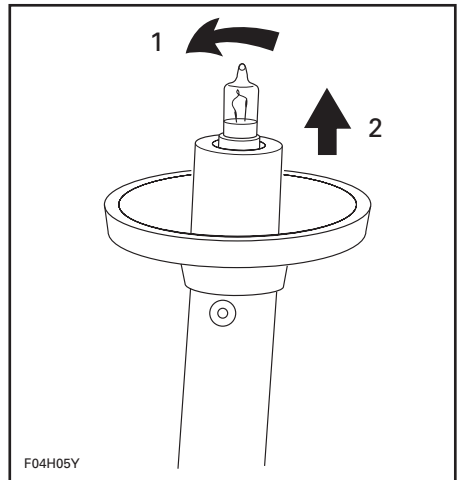

Apply dielectric grease on new bulb contact surface.

**▼ CAUTION**

Avoid finger contact or grease on bulb.

The assembly is essentially the reverse of removal procedure.

## Tube Inflation

Proceed as follows:

Remove valve cap of a rear section by unscrewing it a quarter of a turn counterclockwise.

Check that the center plunger is in the upright position.

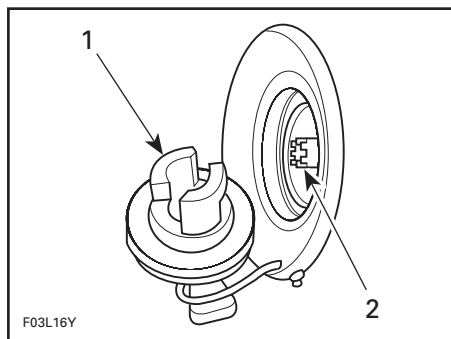

1. Valve cap removed
2. Center plunger upright

Insert foot pump hose end with proper adapter into the valve opening.

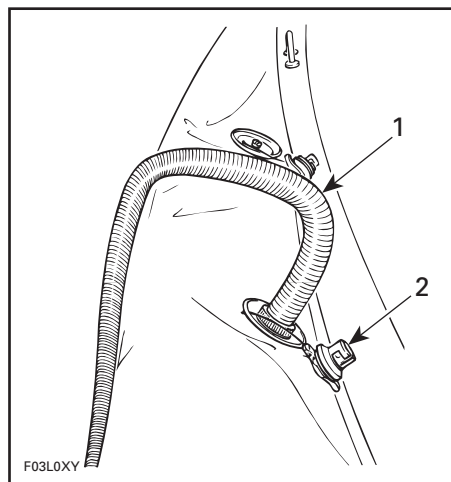

1. Foot pump hose
2. Valve cap

Inflate with one foot by pressing down on the foot pump.

## CAUTION

Always inflate rear sections FIRST. Inflate front section LAST. Never use high pressure to inflate tube, moisture will damage tube seams.

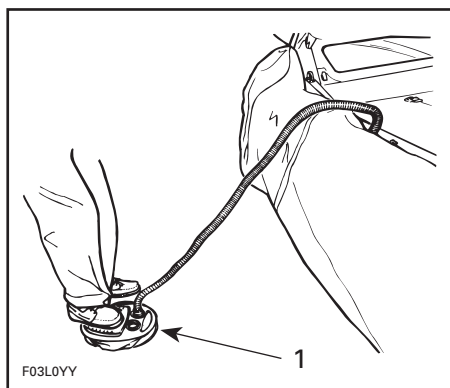

1. Foot pump

**NOTE:** Inflation is sufficient when you can no longer put air into the tube section using one foot.

When inflation is finished, remove foot pump hose end from valve.

Verify pressure using valve adapter (included in tube repair kit) and a low pressure gauge (70 kPa (10 PSI)).

**NOTE:** Seat valve adapter as quickly as possible onto valve opening and firmly maintain in position to avoid air loss.

Pressure must be set at 21 kPa (3 PSI). If pressure is too high, reduce it by slightly pushing the center plunger.



## WARNING

Never inflate tube more than 21 kPa (3 PSI). Inflating tube more than specified pressure may damage tube and possibly cause personal injury.

When pressure is set, screw valve cap.

**NOTE:** It is very important to seal the valve with this cap in order to increase air tightness and to keep out unwanted dirt and water.

Proceed with the same procedure for the remaining tube sections.

## Order of Inflation

The tubes must be inflated to the recommended pressure at all times.

**NOTE:** When you cannot depress the tube with the pressure of your finger, you have reached approximate working pressure.

Air pressure in tube sections should be rechecked while the jet boat is afloat; adjust if necessary, as the temperature of the water may be different from that of the air, which could result in changes in air pressure.

**NOTE:** Exterior air temperature affects tube air pressure; always adjust.

## Tube Deflation

Remove valve cap of any tube sections by unscrewing it a quarter of a turn counterclockwise.

Push and twist the center plunger in either direction to lock it into the open position.

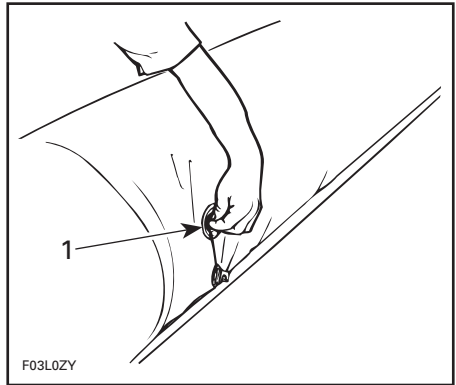

1. Valve button

The tube section will now automatically deflate.

Reinstall valve cap.

Proceed with the same procedure for the remaining tube sections.

## Tube Minor Repairs

### Tear Repair of Less than 5 cm (2 in)

For best results, repairs should be performed in temperatures of 18° to 25°C (64° to 77°F). Avoid carrying out repairs in direct sunlight, rain or in conditions of high humidity.

**NOTE:** For any major repair, refer to an authorized dealer.

Deflate completely tube section to be repaired.

Cut a patch about 75 cm (3 in) larger than the tear in every direction. Always round corners.

Using only a pencil, trace the position of the patch on the tube.



## CAUTION

Do not use pen or felt-tip pen as ink will permanently mark tube.

Sand thoroughly the area of the tube with a 80 grit sandpaper.

○ **NOTE:** Protect tube surface in vicinity with masking tape.

○ **NOTE:** Supplied materials included in repair kit do not need to be sanded.

Remove masking tape.

Clean the patch and tube areas with a solvent such as methyl ethyl ketone, toluene or acetone. Allow solvent to completely evaporate.

Apply a **thin** layer of adhesive (included in repair kit) to the patch and the tube. Allow to dry so that adhesive is dry to the touch.

Apply a second **thin** layer of adhesive on both parts.

Allow the second coat to dry until tacky to the touch; then, apply the patch.

Smooth out the patch with a spoon-shaped tool working from the center to the outside to remove all excess glue and air bubbles.

Allow 24 hours to dry before inflating.

Clean any excess of glue.

## General Inspection and Care

### Inspection

Check engine compartment for any damage and fuel/oil injection systems for leaks. Also check battery vent tube for electrolyte leaks. Ensure all hose clamps are properly secured and no hose is cracked, kinked or presenting any other damage.



### WARNING

If any gasoline leak or odor is found, do not start the engine. Have the jet boat serviced by an authorized dealer. Failure to correct a leak could lead to an explosion.

Inspect muffler, battery and reservoir fastening devices. Check electrical connections for corrosion and tightness.

### Cleaning

Twice a year, the bilge should be cleaned with hot water and detergent or bilge cleaner to remove any possible fuel/oil/electrolyte deposits and mildew.

Occasionally, wash the body with hot water and soap (only use mild detergent). Remove any marine organisms from engine and/or hull. Apply non-abrasive wax such as silicone wax.



### CAUTION

Never clean apparent fiberglass and plastic parts with strong detergent, degreasing agent, paint thinner, acetone, etc.

When the jet boat is operated in foul water and **particularly in salt water**, tube must be rinsed frequently with fresh water.

Occasionally, wash the tube with warm water and soap (only use mild detergent).

Stubborn stains and scuff marks may be removed using methyl ethyl ketone, toluene or acetone.



### CAUTION

Never clean decals with strong detergent, methyl ethyl ketone, toluene or acetone. Limit application of these solvents on tube seams to avoid glue dilution.

# TRANSPORTATION, STORAGE AND PRE-SEASON PREPARATION

## Transportation

### ◆ WARNING

Always turn the fuel valve to OFF position when transporting or storing the jet boat.

Tie the jet boat to both bow and stern (front/rear) eyelets so that it is firmly retained on the trailer. Use additional cables if necessary.

### ▼ CAUTION

Do not route ropes or tie-downs over the seats or tubes as they could produce permanent damage. Wrap ropes or tie-downs with rags or similar protectors where they can touch the jet boat body.

Ensure engine and storage covers are properly latched.

A SEA-DOO cover should protect the jet boat, particularly before driving on dirt roads.

Observe trailering safety precautions.

## Storage

It is recommended that the jet boat be serviced by an authorized dealer for storage but the following operations can be performed by you with a minimum of tools.

### ▼ CAUTION

Do not run the engine during the storage period.

## Engine Draining

Check engine drain tube. Make sure there is no sand or other particles in it and that it is not obstructed so that water can leave the engine. Clean tube and fitting (on outlet) as necessary.

### ▼ CAUTION

Water in engine drain tube must be free to flow out, otherwise water could be trapped in engine. Should water freeze in engine, severe damage will occur. Check engine drain tube for obstructions.

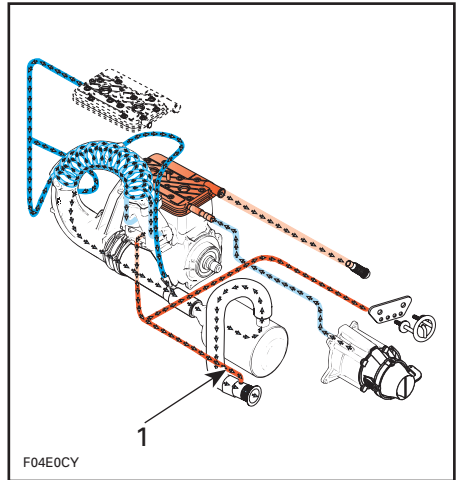

TYPICAL

1. Drain tube

## Boat Rinsing

Thoroughly rinse the hull, bilge and engine compartment with fresh water.



## Propulsion System

Lubricant in impeller shaft reservoir should be drained and reservoir cleaned. Refill with 90 mL (3 U.S. oz) of SEA-DOO synthetic polyolester oil 75W90 GL5 type C gear lube. Refer to an authorized dealer for this operation.

### ▼ CAUTION

Use only BOMBARDIER jet pump oil or equivalent synthetic gear oil, otherwise component service life could be reduced. Do not mix oil brands or types.

Lubricate PTO flywheel and seal carrier. Refer to procedure discussed in MAINTENANCE.

## Fuel System

SEA-DOO fuel stabilizer (or equivalent), can be added in fuel tank to prevent fuel deterioration and carburetor gumming. Follow manufacturer's instructions for proper use.

### ▼ CAUTION

Fuel stabilizer should be added prior engine lubrication to ensure carburetor protection against varnish deposit.

### ◆ WARNING

Fuel is flammable and explosive under certain conditions. Always work in a well ventilated area. Do not smoke or allow open flames or sparks in the vicinity. Always wipe off any fuel spillage from the jet boat. Always turn the fuel valve to OFF position when storing the jet boat.

## Cooling System Flushing and Engine Internal Lubrication

Refer to procedure discussed in POST-OPERATION CARE.

## Battery

Contact your authorized dealer or refer to the appropriate *Shop Manual* for proper storage procedure.

## Anticorrosion Treatment

Wipe off any residual water in the engine compartment.

Spray SEA-DOO LUBE lubricant over metallic components in engine compartment.

## Additional Recommended Protection

In cool regions (where freezing point temperature may be encountered), cooling system should be filled with water and antifreeze solution. (50% water, 50% antifreeze).

### ▼ CAUTION

Always use ethylene glycol anti-freeze containing corrosion inhibitors specifically recommended for aluminum engines.

○ NOTE: The engine does not have to run during this operation.

Three hoses have to be disconnected to allow air to escape and antifreeze solution to completely fill cooling system water jackets.

Install a hose pincher (not supplied) on water injection hose.

Disconnect water inlet hose, drain hose and water outlet hose.

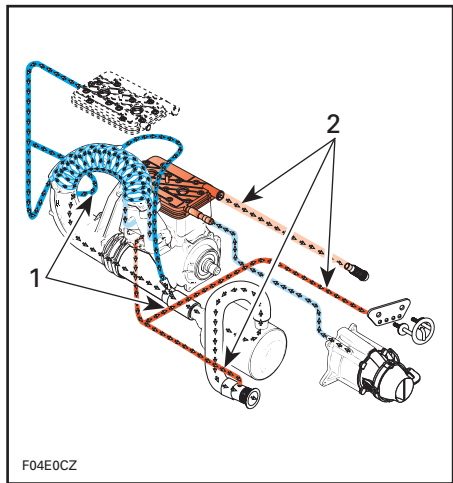

**TYPICAL**

1. Install a hose pincher on water injection hose and CSI hose
2. Disconnect here

Raise all hoses above the highest point of tuned pipe and temporarily tie them together.

Insert a funnel into **inlet hose** going to the water inlet socket at tuned pipe. Pour about 2 liters (1/2 gal) of anti-freeze solution through the funnel.

Tie up all hoses higher than tuned pipe.

**NOTE:** If hoses are not attached higher than tuned pipe, coolant will drain out.

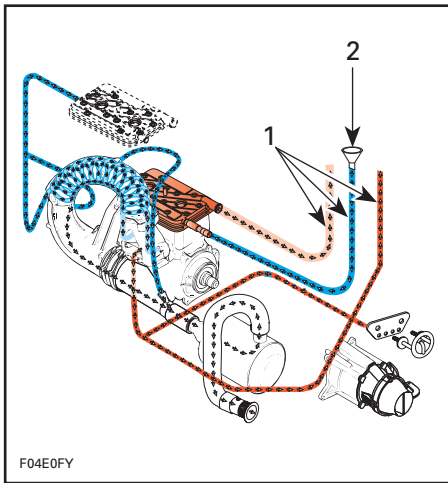

**TYPICAL**

1. Hold hoses higher than tuned pipe
2. Water inlet hose

The following steps should be performed to provide the jet boat enhanced protection.

Remove muffler and drain out as much water as possible. Reinstall muffler.

**OR:** Disconnect one hose from muffler and pour some antifreeze liquid inside muffler. Reconnect hose.

Lubricate the throttle cable with SEA-DOO LUBE lubricant.

Clean the bilge with hot water and detergent or with bilge cleaner. Rinse thoroughly. Lift front end of jet boat to completely drain bilge. If any repairs are needed to body or to the hull, contact your dealer. For paint touch up to mechanical parts use Bombardier spray paint. For small gelcoat repairs, a Bombardier repair kit is available. Replace damaged labels/decals.

---

**NOTE:** Bilge cleaning should be done prior to anticorrosion treatment.

Wash the body with soap and water solution (only use mild detergent). Rinse thoroughly with fresh water. Remove marine organisms from the hull. Apply a nonabrasive wax such as silicone wax.

**▼ CAUTION**

Never clean apparent fiberglass and plastic parts with strong detergent, degreasing agent, paint thinner, acetone, etc.

If the jet boat is to be stored outside, cover it with an opaque tarpaulin to prevent sun rays and grime from affecting the plastic components, jet boat finish as well as preventing dust accumulation.

For storage period, tube should be cleaned and dried.

If possible, store the jet boat with the tube sections 90% inflated. If it is not possible, fold the tube into the hull and tie it loosely into this position.

**▼ CAUTION**

Never leave the jet boat stored in direct sunlight. UV radiation will decrease tube life and dull finish. The jet boat must never be left in water for storage. Keep away from rodents.

The engine cover should be partially left opened during storage. This will avoid engine compartment condensation and possible corrosion.

**NOTE:** If the jet boat is stored outside with engine cover partially opened and without a tarpaulin, unscrew the rear drain plugs in order to avoid water build up in the bilge during rainfall. Tilt the jet boat to the rear so that water can flow out of floorboard.

## Pre-Season Preparation

Use the following chart.

Since technical skills and special tools are required, some operations should be performed by an authorized dealer.

**◆ WARNING**

Observe WARNINGS and CAUTIONS mentioned throughout this guide which are pertinent to the item being checked. When component conditions seem less than satisfactory, replace with genuine BOMBARDIER parts or approved equivalents.

## Pre-Season Preparation Chart

 NOTE: It is highly recommended that the dealer perform at the same time the annual safety inspection in addition to the pre-season preparation.

OPERATIONS	To be performed by
Lubrication/corrosion protection	OPERATOR
Battery condition/charging and reinstallation	DEALER
Battery, starter connections and routing ②	DEALER
Spark plug replacement ①	OPERATOR
Impeller shaft reservoir oil inspection	DEALER
Propulsion system inspection	DEALER
Oil filter replacement	DEALER
Oil injection reservoir filling	OPERATOR
Flame arrester cleaning/inspection ②	DEALER
Fuel filter replacement	DEALER
Fuel line condition ②	DEALER
Filler neck, fuel tank and fuel cap condition ②	DEALER
Check valves, fasteners, fuel system pressurization ②	DEALER
Throttle ② /choke cable inspection/adjustment	DEALER
Oil injection pump adjustment and bleeding	DEALER
Engine ignition timing	DEALER
Carburetor adjustment	DEALER
Steering system alignment/inspection ②	DEALER
Reverse cable adjustment	DEALER
Inspection of deck drain holes/bailer pick-ups	DEALER
Inspection of cooling system inlet/outlet hoses ②	DEALER
Engine overheating beeper	DEALER
fire extinguisher condition/mounting ②	OPERATOR
Tube and tube attachment condition	DEALER

① Before installing new spark plugs, it is suggested to burn the excess SEA-DOO LUBE lubricant by starting the engine using the old spark plugs.

② Safety item covered in the annual safety inspection.

### CAUTION

Coupler hose must be installed or jet boat must be in water to cool engine. Running the engine without cooling water will damage exhaust hose interior and may damage engine.

# TROUBLESHOOTING

The following chart is provided to help in diagnosing the probable source of simple troubles. You may be able to solve many of these problems rather quickly, but others may require the skills of a mechanical technician. In such a case, consult an authorized dealer for servicing.

## ENGINE WILL NOT START

OTHER OBSERVATION	POSSIBLE CAUSE	REMEDY
Engine does not turn over	<ul style="list-style-type: none"> <li>• Safety lanyard removed</li> <li>• Burnt fuse</li> <li>• Discharged battery</li> <li>• Battery connections, corroded or loose</li> <li>• Water-flooded engine</li> </ul>	Install cap over switch. Check wiring then replace fuse. Refer to an authorized dealer. Refer to an authorized dealer.  Refer to <b>Submerged Boat</b> in SPECIAL PROCEDURES.
Engine slowly turns	<ul style="list-style-type: none"> <li>• Discharged or weak battery</li> </ul>	Refer to an authorized dealer.
Engine turns over	<ul style="list-style-type: none"> <li>• Fuel tank empty or water-contaminated</li> <li>• Fuel filter clogged or water-contaminated</li> <li>• Fuel-flooded engine:               <ul style="list-style-type: none"> <li>– Fouled/defective spark plugs</li> <li>– Misuse of choke</li> <li>– Fuel valve closed</li> </ul> </li> </ul>	Refill. Syphon and fill with fresh fuel. Clean, check fuel tank for water.  Replace.  Use only with cold engine. Replace spark plugs. Turn fuel valve to ON position.

## ENGINE MISFIRES, RUNS IRREGULARLY

OTHER OBSERVATION	POSSIBLE CAUSE	REMEDY
Weak spark	<ul style="list-style-type: none"> <li>• Fouled/defective/worn spark plugs</li> <li>• Faulty rev limiter</li> <li>• Too much oil supplied to engine</li> </ul>	Replace.  Refer to an authorized dealer. Improper oil pump adjustment, refer to an authorized dealer.
Lean fuel mixture	<ul style="list-style-type: none"> <li>• Fuel: Level too low, stale or water-contaminated</li> <li>• Fuel filter, clogged or water-contaminated</li> </ul>	Syphon and/or refill.  Refer to an authorized dealer.
Rich fuel mixture (high fuel consumption)	<ul style="list-style-type: none"> <li>• Flame arrester dirty/clogged</li> <li>• Partially closed choke</li> </ul>	Clean or replace.  Refer to an authorized dealer.

## ENGINE OVERHEATS

OTHER OBSERVATION	POSSIBLE CAUSE	REMEDY
Overheating beeper sounds	<ul style="list-style-type: none"> <li>• Clogged jet pump water intake</li> <li>• Incorrect type of fuel or oil</li> <li>• Clogged coolant system</li> </ul>	<p>Clean.</p> <p>Syphon and refill.</p> <p>Flush cooling system with coupler hose.</p>

## ENGINE CONTINUALLY BACKFIRES

OTHER OBSERVATION	POSSIBLE CAUSE	REMEDY
	<ul style="list-style-type: none"> <li>• Faulty rev limiter</li> </ul>	Refer to an authorized dealer.
Weak spark	<ul style="list-style-type: none"> <li>• Fouled/defective/worn spark plugs</li> </ul>	Replace.
Overheated engine	<ul style="list-style-type: none"> <li>• See ENGINE OVERHEATS</li> </ul>	

## ENGINE PINGING OR KNOCKING

OTHER OBSERVATION	POSSIBLE CAUSE	REMEDY
	<ul style="list-style-type: none"> <li>• Poor quality gasoline/low octane</li> <li>• Spark plug heat range too high</li> <li>• Ignition timing</li> </ul>	<p>Use well known quality and recommended gasoline.</p> <p>Use recommended spark plugs.</p> <p>Refer to an authorized dealer.</p>

## ENGINE LACKS ACCELERATION OR POWER

OTHER OBSERVATION	POSSIBLE CAUSE	REMEDY
	<ul style="list-style-type: none"> <li>• Weak spark/incorrect fuel mixture</li> <li>• Water in fuel or injection oil</li> </ul>	<p>Refer to ENGINE MISFIRES...</p> <p>Syphon and replace.</p>
Overheated engine	<ul style="list-style-type: none"> <li>• See ENGINE OVERHEATS</li> </ul>	

## JET BOAT CAN NOT REACH TOP SPEED

OTHER OBSERVATION	POSSIBLE CAUSE	REMEDY
Cavitation	<ul style="list-style-type: none"> <li>• Jet pump water intake clogged</li> <li>• Damaged impeller or boot</li> </ul>	<p>Clean.</p> <p>Replace. Refer to an authorized dealer.</p>

## ABNORMAL NOISE FROM PROPULSION SYSTEM

OTHER OBSERVATION	POSSIBLE CAUSE	REMEDY
Cavitation	<ul style="list-style-type: none"> <li>• Weeds or debris jammed around impeller</li> <li>• Damaged impeller shaft or drive shaft</li> </ul>	<p>Clean and check for damage.</p> <p>Refer to an authorized dealer.</p>

# SPECIFICATIONS

<b>ENGINE</b>		<b>EXPLORER (5824)</b>
Engine type		Bombardier-Rotax 717, 2-stroke
Induction type		Rotary valve
Exhaust system		Water cooled/water injected
Lubrication	Type	Oil injection
	Oil type	BOMBARDIER ROTAX INJECTION OIL
Number of cylinders		2
Displacement		718 cm <sup>3</sup> (43.81 in <sup>3</sup> )
Rev limiter setting		7000 RPM (+100, - 50)
<b>COOLING</b>		
Type		Water cooled, total loss type. Direct flow from propulsion unit.
<b>ELECTRICAL</b>		
Magneto generator output		160 W @ 6000 RPM
Ignition system type		Capacitor discharge ignition (CDI)
Spark plug	Make and type	NGK, BR8ES
	Gap	0.5 - 0.6 mm (.020 - .024 in)
Starting system		Electric starter
Battery		12 V, 19 A
Fuse	Starting system	5 A
	Charging system	15 A
	Lights and auxiliary system	7.5 A
	Blower system	7.5 A
<b>CARBURETION</b>		
Fuel type		Regular unleaded gasoline
Carburetor		Diaphragm type, quantity: 2

<b>PROPULSION</b>		<b>EXPLORER (5824)</b>
Propulsion system		Bombardier Formula Jet Pump
Jet pump type		Axial flow, single stage
Transmission		Direct drive
Impeller shaft reservoir oil type		SEA-DOO synthetic polyolester oil 75W90 gear lube
Pivoting angle of direction (nozzle)		~26°
Minimum required water level for jet pump		90 cm (3 ft)
<b>PERFORMANCE</b>		
Cruising time at full throttle	Fuel tank without reserve	1:05 h
	Fuel tank reserve	13 min.
<b>DIMENSIONS</b>		
Number of passengers ①		1 operator and 4 passengers
Overall length		396 cm (155.9 in)
Overall width		206 cm (81.1 in)
Overall height		132 cm (52 in)
Weight (dry)		323 kg (711 lb)
Load limit (passengers + luggage)		475 kg (1045 lb)
Hull material		Composite (Fiberglass)
Tube material		Neoprene, hypalon, polyester reinforced
<b>CAPACITIES</b>		
Fuel tank		48 L (12.6 U.S. gal)
Impeller shaft reservoir	Capacity	90 mL (3 U.S. oz)
	Oil level	Up to plug
Injection oil reservoir		4.5 L (153 U.S. fl. oz)

① Refer to load limits.

BOMBARDIER INC. reserves the right to make changes in design and specifications and/or to make additions to, or improvements in its products without imposing any obligation upon itself to install them on its products previously manufactured.



# SI\* METRIC INFORMATION GUIDE

BASE UNITS			
DESCRIPTION	UNIT	SYMBOL	
length .....	meter .....	m	
mass .....	kilogram .....	kg	
force .....	newton .....	N	
liquid .....	liter .....	L	
temperature .....	Celsius .....	°C	
pressure .....	kilopascal .....	kPa	
torque .....	newton-meter .....	N•m	
land velocity .....	kilometer per hour .....	km/h	
navigation velocity .....	knot .....	kn	

PREFIXES			
PREFIX	SYMBOL	MEANING	VALUE
kilo .....	k .....	one thousand .....	1000
centi .....	c .....	one hundredth of .....	0.01
milli .....	m .....	one thousandth of .....	0.001
micro .....	μ .....	one millionth of .....	0.000001

CONVERSION FACTORS			
TO CONVERT	TO ①	MULTIPLY BY	
in .....	mm .....	25.4	
in .....	cm .....	2.54	
in <sup>2</sup> .....	cm <sup>2</sup> .....	6.45	
in <sup>3</sup> .....	cm <sup>3</sup> .....	16.39	
ft .....	m .....	0.3	
oz .....	g .....	28.35	
lb .....	kg .....	0.45	
lbf .....	N .....	4.4	
lbf•in .....	N•m .....	0.11	
lbf•ft .....	N•m .....	1.36	
lbf•ft .....	lbf•in .....	12	
PSI .....	kPa .....	6.89	
imp. oz .....	U.S. oz .....	0.96	
imp. oz .....	mL .....	28.41	
imp. gal .....	U.S. gal .....	1.2	
imp. gal .....	L .....	4.55	
U.S. oz .....	mL .....	29.57	
U.S. gal .....	L .....	3.79	
knot .....	MPH .....	1.15	
MPH .....	km / h .....	1.61	
Fahrenheit .....	Celsius .....	(°F - 32) ÷ 1.8	
Celsius .....	Fahrenheit .....	(°C x 1.8) + 32	
hp .....	kW .....	.75	

\* The international system of units abbreviates SI in all languages.  
 ① To obtain the reverse sequence, divide by the given factor. Example: to convert millimeters to inches, divide by 25.4.

○ NOTE: Conversion factors are rounded off to 2 decimals for easier use.



# CHANGE OF ADDRESS

If your address has changed, be sure to fill out and mail the card provided on this page.

Such notification is likewise necessary for your own safety even after expiration of the original warranty, since Bombardier will be in a position to contact you if correction to your watercraft becomes necessary.

**NOTE:** This card is strictly for change of address only.

## CHANGE OF ADDRESS



### CHANGE OF ADDRESS

JET BOAT  
IDENTIFICATION NUMBERS

--	--	--	--

Model Number

--	--	--	--	--	--	--	--	--	--	--	--	--	--	--	--	--	--	--	--	--

Hull Identification Number (H.I.N.)

OLD ADDRESS:

NAME

NO. STREET APT

CITY STATE / PROVINCE ZIP / POSTAL CODE

NEW ADDRESS:

NAME

NO. STREET APT

CITY STATE / PROVINCE ZIP / POSTAL CODE

### STOLEN UNITS

In the event that your watercraft is stolen, you should notify your area's distributor warranty department of such.

Please provide your name, address, phone number, hull identification number and date it was stolen.

Bombardier will provide a list of stolen units to all watercraft dealers on a monthly basis to aid in recovery of such units to their owners.



STAMP

**BOMBARDIER INC.**  
SEA-DOO WARRANTY  
VALCOURT, QUEBEC  
CANADA J0E 2L0