

# OPERATOR'S GUIDE TRAXTER MAX 2003

## EUROPEAN COMMUNITY

INCLUDES SAFETY AND MAINTENANCE INFORMATIONS



### WARNING

Read this guide thoroughly.  
It contains important safety information.  
Minimum recommended age:  
Operator: 16 years old. Passenger: 12 years old.

2 1 9 0 0 0 2 8 1



This *Operator's Guide* utilizes the following symbols to emphasize particular information:



The Safety Alert Symbol indicates a potential personal injury hazard.



Indicates a potentially hazardous situation which, if not avoided, could result in serious injury or death.

**CAUTION:** Denotes an instruction which if not followed, may damage the vehicle and/or components.



**YOUR VEHICLE CAN BE HAZARDOUS TO OPERATE.** A collision or rollover can occur quickly, even during routine maneuvers such as turning and driving on hills or over obstacles, if you fail to take proper precautions.

For your safety, understand and follow all the warnings contained in this *Operator's Guide* and the labels on your vehicle. **Failure to follow these warnings can result in SEVERE INJURY OR DEATH.**

Keep this *Operator's Guide* with the vehicle at all times.



Disregarding any of the safety precautions and instructions contained in this *Operator's Guide*, *Safety Videocassette* and on-product labels could cause injury including the possibility of death!

All safety documentation should remain with the vehicle at the time of sale.

All content of the *Safety Information section* should be interpreted by the reader as a warning which if not followed, may result in injury including the possibility of death.

In USA, products are distributed by Bombardier Motor Corporation of America. In Canada, products are distributed by Bombardier Inc.

The following are trademarks of Bombardier Inc. or its subsidiaries:

BOMBARDIER®

TRAXTER®

ROTAX®

**BOMBARDIER**  
RECREATIONAL PRODUCTS



---

# FOREWORD

Congratulations on your purchase of a new Bombardier® recreational vehicle. It is backed by the Bombardier warranty and a network of authorized Bombardier ATV dealers ready to provide the parts, service or accessories you may require.

Your dealer is committed to your satisfaction. He has taken training to perform the initial set-up and inspection of your vehicle as well as completed the final adjustment before you took possession. At delivery, your dealer would have explained the vehicle for the operation, maintenance and safety features. We trust you have taken full advantage of this! If you need more complete servicing information, please ask your dealer.

At delivery, you were also informed of the warranty coverage and completed the Warranty Registration Form which is to be sent to us for processing. In the near future you should be receiving a warranty card which will confirm our receipt of the registration as well as be used for warranty or recall purposes.

You are invited to contact our customer assistance center should you experience problems which cannot be resolved by an authorized Bombardier ATV dealer.

It is understood that this *Operator's Guide* may be translated into another language. In the event of any discrepancy, the English version shall prevail. Throughout this document the masculine is used to denote the masculine or feminine.

The information and components/system descriptions contained in this document are correct at the time of publication. Bombardier Inc. however, maintains a policy of continuous improvement of its products without imposing upon itself any obligation to install them on products previously manufactured. Due to late changes, some differences between the manufactured product and the descriptions and/or specifications in this *Operator's Guide* may occur. Bombardier Inc. reserves the right at any time to discontinue or change specifications, designs, features, models or equipment without incurring any obligation upon itself.

The illustrations in this document show the typical construction of the different assemblies and may not reproduce the full detail or exact shape of the parts. However, they represent parts that have the same or similar function.

The use of RIGHT and LEFT indications in the text, always refers to driving position (when sitting on vehicle).

Specifications are given in the SI metric system with the SAE U.S. equivalent in parenthesis. Where precise accuracy is not required, some conversions are rounded off for easier use.

We recommend genuine Bombardier products for replacement parts and accessories. They've been especially designed for your vehicle and manufactured to meet Bombardier's demanding standards.

A *Shop Manual* can be obtained for complete service, maintenance and more repair information.

---

# TABLE OF CONTENTS

While reading this *Operator's guide*, remember that:

## WARNING

Indicates a potential hazard that, if not avoided, could result in serious injury or death.

<b>NOTICE</b> .....	<b>5</b>
European Community.....	5
<b>INTRODUCTION</b> .....	<b>6</b>
<b>SAFETY INFORMATION</b>	
<b>SPECIAL SAFETY MESSAGES</b> .....	<b>9</b>
<b>OPERATION WARNINGS</b> .....	<b>12</b>
<b>SAFETY WARNING</b> .....	<b>39</b>
Riding Tips .....	40
Clothing .....	41
Carrying Loads/Passenger.....	42
Hauling a Trailer .....	42
Working with your Vehicle.....	42
Recreational Riding.....	43
Environment .....	43
Design Limitation.....	44
Off-Highway Operation.....	44
General Operating and Safety Precautions.....	44
Uphill Driving .....	45
Downhill Driving .....	45
Side Hilling.....	45
Drop-Offs.....	45
Riding Techniques .....	46
Routine Maintenance .....	52
<b>HANG TAG</b> .....	<b>53</b>
<b>LOCATION OF THE IMPORTANT LABELS</b> .....	<b>54</b>
<b>VEHICLE INFORMATION</b>	
<b>HOW TO IDENTIFY YOUR VEHICLE</b> .....	<b>60</b>
Engine and Vehicle Identification Number Location .....	60
<b>CONTROLS/INSTRUMENTS/EQUIPMENTS</b> .....	<b>61</b>
1) Throttle Lever.....	63
2) Front Brake Lever .....	63
3) Rear Brake Lever .....	63

4) Brake Lever Lock .....	64
5) Transmission Lever.....	64
6) Transmission Lever Lock .....	65
7) Outer Multi-Function Switch.....	65
8) Inner Multi-Function Switch.....	67
9) Hazard Warning Button.....	68
10) Indicator Lights Cluster .....	69
11) Speedometer .....	70
12) Rear Passenger Grab Handles .....	72
13) Backrest.....	72
14) Ignition Switch .....	72
15) Choke Knob Lever.....	73
16) Fuel Tank Cap .....	73
17) Fuel Gauge.....	73
18) Fuel Valve.....	74
19) Rear Brake Pedal.....	74
20) Rewind Starter Handle .....	75
21) Footpeg.....	75
22) Foot Board .....	75
23) Storage Compartment .....	75
24) Tool Box.....	76
25) Seat Latch.....	76
26) Front/Rear Cargo Racks .....	77
27) Air Duct.....	77
28) Trailer Hitch.....	77
29) Radiator Cap.....	77
30) 12-Volt Power Outlet .....	78
31) Fuses .....	78

**LIQUIDS..... 79**

Fuel.....	79
Engine/Transmission Oil.....	79
Engine Coolant .....	81
Brake Fluid.....	82
Battery Electrolyte.....	83

**BREAK-IN PERIOD ..... 85**

Engine .....	85
10-Hour Inspection .....	85

**PRE-OPERATION CHECK ..... 86**

**OPERATING INSTRUCTIONS ..... 87**

General.....	87
Initial Cold Starting .....	87
Warm Engine Starting .....	88

Emergency Manual Starting .....	88
Stopping the Engine .....	88
Shifting the Transmission .....	88
<b>SPECIAL PROCEDURES .....</b>	<b>90</b>
Flooded Engine .....	90
Engine Overheat .....	90
Flipped Over .....	90
Vehicle Immersion .....	90
Post-Operation Care .....	91
Emergency Shifter .....	91
Storage and Preseason Preparation .....	92
<b>CARGO AND TRANSPORTATION .....</b>	<b>93</b>
Cargo .....	93
Transportation .....	94
<b><i>MAINTENANCE INFORMATION</i></b>	
<b>MAINTENANCE CHART .....</b>	<b>96</b>
<b>MAINTENANCE .....</b>	<b>98</b>
Engine/Transmission .....	98
Air Intake System .....	101
Electrical .....	102
Drive Train .....	106
Steering/Control Systems .....	108
Suspension .....	109
Brake .....	110
Body/Frame .....	110
<b>TROUBLESHOOTING .....</b>	<b>111</b>
<b>SPECIFICATIONS .....</b>	<b>114</b>
<b>SI METRIC INFORMATION GUIDE .....</b>	<b>118</b>
<b><i>WARRANTY</i></b>	
<b>BOMBARDIER LIMITED WARRANTY INTERNATIONAL: 2003 BOMBARDIER® TRAXTER® MAX .....</b>	<b>120</b>
<b>FREQUENTLY ASKED QUESTIONS .....</b>	<b>123</b>
<b>PRIVACY OBLIGATIONS/DISCLAIMER .....</b>	<b>125</b>
<b>CHANGE OF ADDRESS/OWNERSHIP .....</b>	<b>127</b>

---

# NOTICE

This *Operator's Guide* has been prepared to acquaint the owner/operator of a new vehicle with the various vehicle controls, maintenance and safe operating instructions. They are indispensable for the proper use of the product.

This *Operator's Guide* uses the following symbols.

## **WARNING**

Indicates a potentially hazardous situation which, if not avoided, could result in serious injury or death.

**CAUTION:** Denotes an instruction which, if not followed, could severely damage vehicle components.

**NOTE:** Indicates supplementary information needed to fully complete an instruction.

Although the mere reading of such information does not eliminate the hazard, the understanding and application of the information will promote the correct use of this vehicle.

To fully appreciate the pleasures, enjoyment and excitement of using this vehicle, there are some basic rules that **MUST** be observed and followed by any user.

## European Community

This warning applies only in the European Countries where on road usage is allowed.

## **WARNING**

On road use:

This vehicle is built for OFF-ROAD purposes only. It may be used for short distances on paved surfaces at reduced speed, in order to move the vehicle from an off-road location to another.

When driving this vehicle on roads, always refrain from speeding and substantially reduce vehicle speed when turning.

Failure to do so can cause a loss of vehicle control, possibly resulting in serious injury.

Front winch:

The front winch hook of the so equipped vehicle must be removed and stored when riding the vehicle on public trails and/or roads.

Failure to do so can increase the risk of injury to bystanders.

---

# INTRODUCTION

Your selling dealer should have provided you with some basic information on the particular controls and features of your new vehicle. Please take the time to study this *Operator's Guide* and all on-product warning labels as well as *safety videocassette* that came with this vehicle. They more completely describe what you should know about this vehicle before riding it.

Whether you are a new user or an experienced rider, it is important for your personal safety as well as passenger safety that you know the controls and features of this vehicle. Equally important is knowing how to properly ride.

Irrespective of your age, experience or state regulations, it is always prudent for you or any other person who may ride your vehicle, to take an approved safe riding course. Please check with your dealer or local authorities for availability in your area. If you are a completely new rider, this should be done before your first ride. Your instructor should be able to provide advice on local conditions and safe riding practices particular to the areas.

Riding conditions vary from place to place. Each is subject to weather conditions which may radically change from time to time and from season to season. Riding on sand is different than riding on snow or through forests or marshes. Each location may require a greater degree of awareness and skill and may not be suitable with a passenger, show good judgement. Always proceed with caution. Please do not take any unnecessary risks that could leave you or your passenger stranded or possibly injured.

The vehicle handling, stability and braking distance may be affected when riding with a passenger. Safely reduce speed when riding with a passenger. Allow greater distance for braking.

The contents of this *Operator's Guide* provide riding information which has been proven reliable by other users. They are not intended as a definitive means to avoiding accidents. How you apply this information, coupled with your mental and physical condition, the particular terrain hazard and your acceptance level to risk will have an effect on your riding experience. Have fun... and ride responsibly.

This *Operator's Guide* has been prepared to acquaint the owner/operator of a new vehicle with the various vehicle controls, maintenance and safe operating instructions. They are indispensable for the proper use of the product.

We would be pleased to receive any comments on the content and format of this *Operator's Guide*, *Safety Videocassette* or on-product warnings labels.



# ***SAFETY INFORMATION***

## WARNING

Failure to follow the following recommendations could result in severe injuries including the possibility of death for the passenger and/or the operator:

### **Operator:**

No one under 16 should operate this vehicle.

Never carry more than one passenger on this vehicle.

The operator is responsible for the safety of his passenger. In doubt, disembark the passenger before executing any maneuver.

Remember that vehicle handling, stability and braking distance may be affected when riding with a passenger. Safely reduce speed when riding with a passenger. Allow greater distance for braking.

Always practice the maneuvers described in this *Operator's Guide* without carrying a passenger first and then with a passenger.

Inform the passenger concerning the basic rules for a safety ride.

### **Passenger:**

Passenger should be 12 years old or more and must be capable of completely lean his feet on the footrests and his hands on grab handles at all time when seated on the vehicle.

Passenger should always hold on to rear passenger grab handles. Never hold on to operator.

Passenger should pay attention to vehicle and operator movements.

Never get up during vehicle operation. An excessive movement would cause loss of control.

### **Operator and Passenger:**

Operator and passenger should always wear an approved helmet (with a rigid chin guard for the passenger), eye protection and protective clothing.

Operator and passenger should always keep both hands on the handlebars or on the grab handles and both feet on footrests during vehicle operation.

---

# SPECIAL SAFETY MESSAGES

## THIS VEHICLE IS NOT A TOY AND CAN BE HAZARDOUS TO OPERATE.

This vehicle handles differently from other vehicles including motorcycles and cars. A collision or rollover can occur quickly, even during routine maneuvers such as turning and driving on hills or over obstacles, if you fail to take proper precautions.

**SEVERE INJURY OR DEATH** can result if you do not follow these instructions:

- ⚠ Read this *Operator's Guide* and all on-product warnings labels carefully and follow the operating procedures described. Watch with attention the *Safety Videocassette* before operation.
- ⚠ Never operate this vehicle without proper instruction. **Take a training course.** Beginners should receive training from a certified instructor. Contact an authorized Bombardier ATV dealer to find out about the available training courses.
- ⚠ Always follow this age recommendation: A person under 16 years old should never operate this vehicle.
- ⚠ Never carry more than one passenger on this vehicle. This passenger should be 12 years old or more and must be able to completely lean his feet on footrests and his hands on grab handles at all time when seated on the vehicle.
- ⚠ The vehicle handling, stability and braking distance may be affected when riding with a passenger. Safely reduce speed when riding with a passenger. Allow greater distance for braking.
- ⚠ Never operate this vehicle on any paved surfaces, including sidewalks, driveways, parking lots and streets.
- ⚠ Never operate this vehicle on any public street, road or highway, even a dirt or gravel one.
- ⚠ Never take place on this vehicle without wearing an approved helmet that fits properly. The operator and the passenger should also wear eye protection (goggles or face shield), gloves, boots, long sleeved shirt or jacket, and long pants. The passenger should also have a rigid chin guard included in his helmet.
- ⚠ Never consume alcohol or drugs before or while riding this vehicle.
- ⚠ Never operate at excessive speeds. Always go at a speed that is proper for the terrain, visibility, and operating conditions, and your experience.
- ⚠ Never attempt wheelies, jumps, or other stunts.
- ⚠ Always inspect your vehicle each time you use it to make sure it is in safe operating condition. Always follow the inspection and maintenance procedures and schedules described further in this *Operator's Guide*.
- ⚠ The operator and the passenger must always keep both hands on the handlebars or grab handles and both feet on the footrests of the vehicle during operation.
- ⚠ Always go slowly and be extra careful when operating on unfamiliar terrain. Always be alert to changing terrain conditions when operating this vehicle. Always keep in mind that you are carrying a passenger.

- ⚠ Never operate on excessively rough, slippery or loose terrain until you have learned and practiced the skills necessary to control this vehicle on such terrain. Always be especially cautious on these kinds of terrain. Always keep in mind that you are carrying a passenger.
- ⚠ Always follow proper procedures for turning as described further in this *Operator's Guide*. Practice turning at low speeds before attempting to turn at faster speeds. Do not turn at excessive speed. Carrying a passenger may affect the stability and the handling of the vehicle.
- ⚠ Never operate this vehicle on hills too steep for the vehicle or for your abilities. Practice on smaller hills before attempting larger hills. Do not forget, the operator is responsible for the safety of his passenger. In doubt, disembark the passenger before climbing hill. Always remember that the vehicle handling, stability and braking distance may be affected when riding with a passenger.
- ⚠ Always follow proper procedures for climbing hills as described further in this *Operator's Guide*. Check the terrain carefully before you start up any hill. Never climb hills with excessively slippery or loose surfaces. Operator and passenger must shift their weight forward. Never open the throttle suddenly or make sudden gear changes. Never go over the top of any hill at high speed. Always keep in mind that you are carrying a passenger.
- ⚠ Always follow proper procedures for going down hills and for braking on hills as described further in this *Operator's Guide*. Check the terrain carefully before you start down any hill. Operator and passenger must shift their weight backward. Passenger must hold grab handles firmly. Never go down a hill at high speed. Avoid going down a hill at an angle that would cause the vehicle to lean sharply to one side. Go straight down the hill where possible. Always keep in mind that you are carrying a passenger.
- ⚠ Always follow proper procedures for crossing the side of a hill as described further in this *Operator's Guide*. Avoid hills with excessively slippery or loose surfaces. Operator and passenger must shift their weight to the uphill side of the vehicle. Never attempt to turn the vehicle around on any hill until you have mastered the turning technique described further in this *Operator's Guide* on level ground. Avoid crossing the side of a steep hill if possible. Always keep in mind that you are carrying a passenger.
- ⚠ Always use proper procedures if you stall or roll backwards when climbing a hill. To avoid stalling, use proper gear and maintain a steady speed when climbing a hill. If you stall or roll backwards, follow the special procedure for braking described further in this *Operator's Guide*. First, disembark the passenger then dismount on the uphill side or to a side if pointed straight uphill. Turn the vehicle around and remount, following the procedure described further in this *Operator's Guide*.
- ⚠ Always check for obstacles before operating in a new area. Never attempt to operate over large obstacles, such as large rocks or fallen trees. Always follow proper procedures when operating over obstacles as described in this *Operator's Guide*. Do not forget, the operator is responsible for the safety of his passenger. In doubt, disembark the passenger to get through the obstacles.

- ⚠ Always be careful when skidding or sliding. Never skid or slide with a passenger as an overturn or passenger ejection may occur. Learn to safely control skidding or sliding by practicing at low speeds and on level, smooth terrain. On extremely slippery surfaces, such as ice, go slowly and be very cautious in order to reduce the chance of skidding out of control.
- ⚠ Never operate this vehicle in fast flowing water or in water deeper than that specified further in this *Operator's Guide*. Remember that wet brakes may have reduced stopping ability. Test your brakes after leaving water. If necessary, apply them several times to let friction dry out the pads. The vehicle braking distance may be affected when riding with a passenger. Safely reduce speed when riding with a passenger. Allow greater distance for braking.
- ⚠ Always be sure there are no obstacles or people behind the vehicle when you operate in reverse. When it is safe to proceed in reverse, go slowly. Take into account that the passenger can obstruct your view.
- ⚠ Always use the size and type tires specified further in this *Operator's Guide*. Always maintain proper tire pressure as described further in this *Operator's Guide*.
- ⚠ Never modify this vehicle through improper installation or use of accessories. Only use approved Bombardier accessories. Do not install passenger seats or use the racks to carry more than one passenger.
- ⚠ Never exceed the stated load limits for this vehicle including operator and passenger, all other loads and added accessories. Cargo should be properly distributed and securely attached. Reduce speed and follow instructions in this *Operator's Guide* for carrying cargo or pulling a trailer. Allow greater distance for braking.
- ⚠ **FOR MORE INFORMATION ABOUT ATV SAFETY**, contact an authorized Bombardier ATV dealer to find out about the training courses nearest you.
- ⚠ Do not forget, the operator is responsible for the safety of his passenger. If in doubt, disembark the passenger. Always practice the maneuvers described further in this *Operator's Guide* without and with passenger. Always remember that the vehicle handling, stability and braking distance may be affected when riding with a passenger. Safely reduce speed when riding with a passenger. Allow greater distance for braking. This vehicle can perform many maneuvers easily with the operator alone but with a passenger, such maneuvers could be difficult or impossible. Use your common sense.

# OPERATION WARNINGS

While reading this *Operator's Guide*, remember that:

## WARNING

Indicates a potential hazard that, if not avoided, could result in serious injury or death.

**NOTE:** The following illustrations are general representations only. Your model may differ.

## WARNING



V00A0AQ

### **POTENTIAL HAZARD**

Operating this vehicle without proper instruction.

### **WHAT CAN HAPPEN**

The risk of an accident is greatly increased if the operator does not know how to operate this vehicle properly in different situations and on different types of terrain with or without passenger.

### **HOW TO AVOID THE HAZARD**

Beginning and inexperienced operators should complete the certified training course offered by Bombardier Inc. They should then regularly practice the skills learned in the course and the operating techniques described in this *Operator's Guide*.

For more information about the training course, contact a local authorized Bombardier ATV dealer.



V00A1AQ

**POTENTIAL HAZARD**

Failure to follow the age recommendations for this vehicle.

**WHAT CAN HAPPEN**

The no respect of this age recommendations can lead to severe injury or death of the child.

Even though a child may be within the age group for which this vehicle is recommended, he may not have the skills, abilities, or judgment needed to operate this vehicle safely and may be involved in a serious accident.

**HOW TO AVOID THE HAZARD**

No one under 16 should operate this Bombardier vehicle.

 **WARNING**



V00A1BQ

**POTENTIAL HAZARD**

Failure to follow the age recommendations for the passenger.

**WHAT CAN HAPPEN**

A child, under 12, may not have the ability needed to ride safely and may be involved in a serious accident.

**HOW TO AVOID THE HAZARD**

No one under 12 should be riding on this vehicle.

 **WARNING**

**POTENTIAL HAZARD**

Failure to respect the physical limitations for the passenger.

**WHAT CAN HAPPEN**

A passenger that cannot completely lean his feet on footrests can be ejected when riding on uneven terrain.

**HOW TO AVOID THE HAZARD**

The passenger must be able to completely lean his feet on the footrests and his hands on grab handles at all time when seated on the vehicle.



**⚠ WARNING**



V00A1CQ

**POTENTIAL HAZARD**

Carrying more than one passenger on this vehicle.

**WHAT CAN HAPPEN**

Carrying more than one passenger greatly reduced your ability to balance and control this vehicle.

Could cause an accident, resulting in harm to you and/or your passengers.

**HOW TO AVOID THE HAZARD**

Never carry more than one passenger. The long seat is to allow the operator and the passenger to shift position as needed during operation.

## **WARNING**



V00A1EQ

### **POTENTIAL HAZARD**

Operating this vehicle on public streets, roads or highways.

### **WHAT CAN HAPPEN**

You can collide with another vehicle. Paved surfaces may seriously affect handling and control of the vehicle, and may cause the vehicle to go out of control.

### **HOW TO AVOID THE HAZARD**

If a road usage is allowed in your area, operate your vehicle on paved surface only for short distance and for the only purpose of moving the vehicle from an off-road usage to another.

Always operate your vehicle at low speed (never exceed 65 km/h (40 MPH)) and reduce the speed before making a turn.

Always respect all road traffic laws when operating your vehicle on public roads or streets.

## **WARNING**



V00A1FQ

### **POTENTIAL HAZARD**

Riding this vehicle without wearing an approved helmet (with rigid chin guard for the passenger), eye protection and protective clothing.

### **WHAT CAN HAPPEN**

For the operator and the passenger:

- riding without an approved motorcycle helmet increases the chances of a severe head injury or death in the event of an accident
- riding without eye protection can result in an accident and increases the chances of a severe injury in the event of an accident
- riding without protective clothing increases the chances of severe injury in the event of an accident.

### **HOW TO AVOID THE HAZARD**

Always wear an approved motorcycle helmet that fits properly. You should also wear:

- eye protection (goggles or face shield)
- rigid chin guard (recommended for the passenger)
- gloves and boots
- long sleeved shirt or jacket
- long pants.

## WARNING



V00A07Q

### **POTENTIAL HAZARD**

Riding this vehicle after consuming alcohol or drugs.

### **WHAT CAN HAPPEN**

Operator and passenger:

Could seriously affect your judgment.

Could cause you to react more slowly.

Could affect your balance and perception.

Could result in an accident.

### **HOW TO AVOID THE HAZARD**

The operator and the passenger should never consume alcohol or drugs before or while riding this vehicle.

## **WARNING**

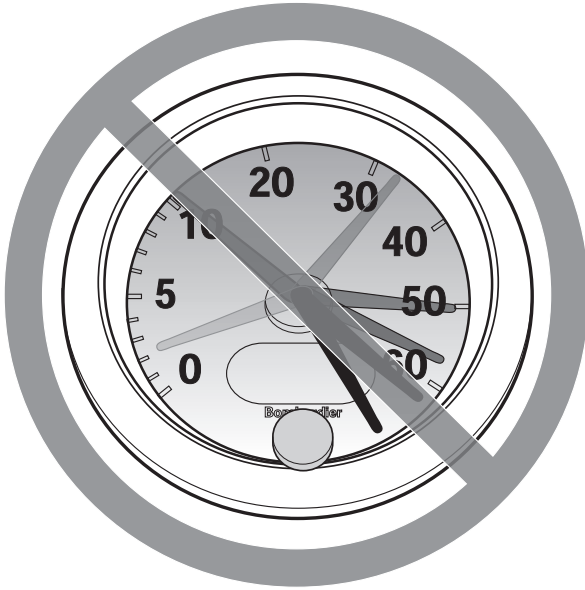

V00A08Q

### **POTENTIAL HAZARD**

Operating this vehicle at excessive speeds.

### **WHAT CAN HAPPEN**

Increases your chances of losing control of the vehicle, which can result in an accident.

### **HOW TO AVOID THE HAZARD**

Always travel at a speed which is proper for the terrain, visibility and operating conditions, and your experience.

The vehicle handling, stability and braking distance may be affected when riding with a passenger. Safely reduce speed when riding with a passenger. Allow greater distance for braking.

The maximum speed authorized with this vehicle is 65 km/h (40 MPH). Always reduce speed before making a turn.

**⚠ WARNING**



V00A1GQ

**POTENTIAL HAZARD**

Attempting wheelies, jumps and other stunts.

**WHAT CAN HAPPEN**

Increases the chance of an accident, for the operator and the passenger, including an overturn.

**HOW TO AVOID THE HAZARD**

Never attempt stunts, such as wheelies or jumps. Do not try to show off.

 **WARNING**

**POTENTIAL HAZARD**

Failure to inspect the vehicle before operating.  
Failure to properly maintain the vehicle.

**WHAT CAN HAPPEN**

Increases the possibility of an accident or equipment damage.

**HOW TO AVOID THE HAZARD**

Always inspect your vehicle each time you use it to make sure the vehicle is in safe operating condition.

Always follow the inspection and maintenance procedures and schedules described further in this *Operator's Guide*.

 **WARNING**

**POTENTIAL HAZARD**

Riding on frozen waterways.

**WHAT CAN HAPPEN**

Severe injury or death can result if the vehicle and/or operator and/or passenger break through the ice.

**HOW TO AVOID THE HAZARD**

Never ride this vehicle on a frozen surface before you are sure the ice is thick enough and sound enough to support the vehicle and its load, as well as the force that is created by a moving vehicle.

## **WARNING**



V00A1HQ

### **POTENTIAL HAZARD**

Removing hands from handlebars for the operator and from handle grips for the passenger, or feet from the footrests during operation.

### **WHAT CAN HAPPEN**

Removing even one hand or foot can reduce your ability to control the vehicle or could cause you to lose your balance and fall off the vehicle. If you remove a foot from the footrests, your foot or leg may come into contact with the rear wheels, which could injure you or cause an accident.

### **HOW TO AVOID THE HAZARD**

Operator and passenger must always keep both hands on the handlebars or on handle grips and both feet on the footrests during vehicle operation.



## WARNING



V00A11Q

### **POTENTIAL HAZARD**

Failure to use extra care when operating this vehicle on unfamiliar terrain.

### **WHAT CAN HAPPEN**

You can come upon hidden rocks, bumps, or holes, without enough time to react.

Could result in the vehicle overturning, passenger ejection or going out of control.

### **HOW TO AVOID THE HAZARD**

Go slowly and be extra careful when operating on unfamiliar terrain.

Always be alert to changing terrain conditions when operating the vehicle.

Do not forget, the operator is responsible for the safety of his passenger. Safely reduce speed when riding with a passenger.

## WARNING



V00A1JQ

### **POTENTIAL HAZARD**

Failure to use extra care when operating on excessively rough, slippery or loose terrain.

### **WHAT CAN HAPPEN**

Could cause loss of traction or vehicle control, which could result in an accident, including an overturn or passenger ejection.

### **HOW TO AVOID THE HAZARD**

Do not operate on excessively rough, slippery or loose terrain until you have learned and practiced the skills necessary to control this vehicle on such terrain.

Always be especially cautious on these kinds of terrain.

Do not forget, the operator is responsible for the safety of his passenger. In doubt, disembark the passenger before operating on these terrains.

**⚠ WARNING**



V00A1K0

**POTENTIAL HAZARD**

Turning improperly.

**WHAT CAN HAPPEN**

Vehicle could go out of control, causing a collision, an overturn or a passenger ejection.

**HOW TO AVOID THE HAZARD**

Always follow proper procedures for turning as described in this *Operator's Guide*. Practice turning at low speeds before attempting to turn at faster speeds.

Do not forget, the operator is responsible for the safety of his passenger. Always remember that the vehicle handling, stability and braking distance may be affected when riding with a passenger.

Do not turn at excessive speed.

## WARNING



V00A1LQ

### **POTENTIAL HAZARD**

Operating on excessively steep hills.

### **WHAT CAN HAPPEN**

The vehicle can overturn more easily on extremely steep hills than on level surfaces or small hills.

### **HOW TO AVOID THE HAZARD**

Never operate this vehicle on hills too steep for the vehicle or for your abilities.

Practice, without and with passenger, on smaller hills before attempting larger hills.

Always remember that, even if this vehicle can climb some steep hills, it is not recommended to climb such hills with a passenger. Always disembark him before attempting this maneuver. Show good judgement.

## WARNING



V00A1MQ

### **POTENTIAL HAZARD**

Climbing hills improperly.

### **WHAT CAN HAPPEN**

Could cause loss of control, passenger ejection or cause vehicle to overturn.

### **HOW TO AVOID THE HAZARD**

Always follow proper procedures for climbing hills as described further in this *Operator's Guide*.

Always check the terrain carefully before you start up any hill. Do not forget, the operator is responsible for the safety of the passenger. In doubt, disembark the passenger before climbing hill. Always remember that the vehicle handling, stability and braking distance may be affected when riding with a passenger.

Never climb hills with excessively slippery or loose surfaces.

Operator and passenger must shift their weight forward.

Never open the throttle suddenly or make sudden gear changes. The vehicle could flip over backwards.

Never go over the top of any hill at high speed. An obstacle, a sharp drop, or another vehicle or person could be on the other side of the hill.

## WARNING



V00A1NQ

### **POTENTIAL HAZARD**

Going down a hill improperly.

### **WHAT CAN HAPPEN**

Could cause loss of control, passenger ejection or cause vehicle to overturn.

### **HOW TO AVOID THE HAZARD**

Always follow proper procedures for going down hills as described further in this *Operator's Guide*. **NOTE:** A special technique is required when braking as you go down a hill.

Always check the terrain carefully before you start down any hill. Do not forget, the operator is responsible for the safety of the passenger. In doubt, disembark the passenger before climbing hill. Always remember that the vehicle handling, stability and braking distance may be affected when riding with a passenger.

Operator and passenger must shift their weight backward. The passenger must hold grab handles firmly.

Never go down a hill at high speed.

Avoid going down a hill at an angle which would cause the vehicle to lean sharply to one side. Go straight down the hill where possible.

## WARNING



V00A10Q

### **POTENTIAL HAZARD**

Improperly crossing hills or turning on hills.

### **WHAT CAN HAPPEN**

Could cause loss of control, passenger ejection or cause vehicle to overturn.

### **HOW TO AVOID THE HAZARD**

Never attempt to turn the vehicle around when the passenger is on board. Always disembark him before executing such maneuvers.

Never attempt to turn the vehicle around on any hill until you have mastered the turning technique as described further in this *Operator's Guide* on level ground. Be very careful when turning on any hill.

Avoid crossing the side of a steep hill if possible.

#### **When crossing the side of a hill:**

Always follow proper procedures as described further in this *Operator's Guide*.

Avoid hills with excessively slippery or loose surfaces.

Operator and passenger must shift their weight to the uphill side of the vehicle.

## WARNING

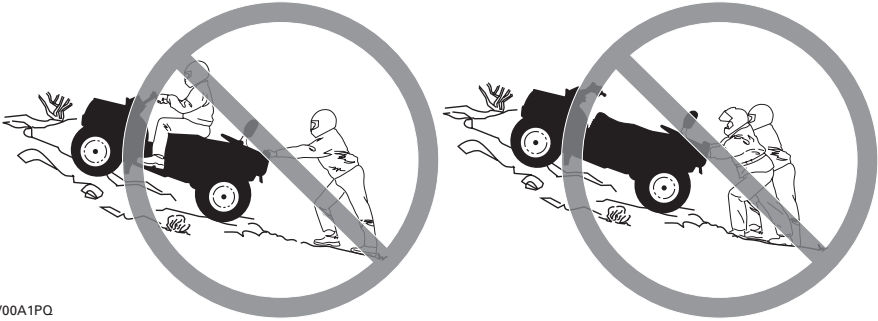

V00A1PQ

### **POTENTIAL HAZARD**

Stalling, rolling backwards or improperly dismounting while climbing a hill.

### **WHAT CAN HAPPEN**

Could result in vehicle overturning.

### **HOW TO AVOID THE HAZARD**

Use proper gear and maintain steady speed when climbing a hill.

#### **If you lose all forward speed:**

Operator and passenger must keep their weight uphill. Never open the throttle suddenly or make sudden gear changes. The vehicle could flip over backwards.

Apply the brakes.

Lock parking brake after you are stopped.

First, disembark the passenger, then dismount on uphill side, or to a side if pointed straight uphill.

#### **If you begin rolling backwards:**

Operator and passenger must keep their weight uphill. Never open the throttle suddenly or make sudden gear changes. The vehicle could flip over backwards.

Never apply the rear brake while rolling backwards.

Apply the front brake gradually.

When fully stopped, apply rear brake as well and lock parking brake.

First, disembark the passenger, then dismount on uphill side, or to a side if pointed straight uphill.

Turn the vehicle around and remount, following the procedure described further in this *Operator's Guide*.



## WARNING



V00A1QQ

### **POTENTIAL HAZARD**

Improperly operating over obstacles.

### **WHAT CAN HAPPEN**

Could cause loss of control, passenger ejection or a collision.

Could cause the vehicle to overturn.

### **HOW TO AVOID THE HAZARD**

The operator is responsible for the safety of his passenger. In doubt, disembark the passenger before riding over obstacles. Always remember that the vehicle handling and stability may be affected when riding with a passenger.

Before operating in a new area, check for obstacles.

Never attempt to ride over large obstacles, such as large rocks or fallen trees.

When you go over obstacles, always follow proper procedures as described further in this *Operator's Guide*.

## WARNING



V00A1RQ

### **POTENTIAL HAZARD**

Skidding or sliding improperly.

### **WHAT CAN HAPPEN**

You may lose control of this vehicle.

You may also regain traction unexpectedly, which may cause the vehicle to overturn or passenger ejection.

### **HOW TO AVOID THE HAZARD**

Never slide or skid with passenger. Always remember that this vehicle handling and stability may be affected when riding with a passenger.

Learn to safely control skidding or sliding by practicing at low speeds and on level, smooth terrain.

On extremely slippery surfaces, such as ice, go slowly and be very cautious in order to reduce the chance of skidding or sliding out of control.

**⚠ WARNING**



V00A1SQ

**POTENTIAL HAZARD**

Operating this vehicle through deep or fast flowing water.

**WHAT CAN HAPPEN**

Tires may float, causing loss of traction and loss of control, which could lead to an accident.

**HOW TO AVOID THE HAZARD**

Never operate this vehicle in fast flowing water or in water deeper than that specified further in this *Operator's Guide*.

Check water depth and current before you attempt to cross any water. Water should not go above footrests.

Remember that wet brakes may have reduced stopping ability. Test your brakes after leaving water. If necessary, apply them several times to let friction dry out the pads. Do not forget, allow greater distance for braking when you ride with a passenger.

**⚠ WARNING**



V00A1TQ

**POTENTIAL HAZARD**

Improperly operating in reverse.

**WHAT CAN HAPPEN**

You could hit an obstacle or person behind the vehicle, resulting in serious injury.

**HOW TO AVOID THE HAZARD**

When you select reverse gear, make sure there are no obstacles or people behind the vehicle. When it is safe to proceed, go slowly. Take into account that the passenger can obstruct your view.

**⚠ WARNING**



V00A00Q

**POTENTIAL HAZARD**

Operating this vehicle with improper tires, or with improper or uneven tire pressure.

**WHAT CAN HAPPEN**

Use of improper tires on this vehicle, or operation of this vehicle with improper or uneven tire pressure, may cause loss of control, and increases the risk of an accident.

**HOW TO AVOID THE HAZARD**

Always use the size and type tires specified further in this *Operator's Guide* for this vehicle.

Always maintain proper tire pressure as described further in this *Operator's Guide*.

**⚠ WARNING**



V00A26Q

**POTENTIAL HAZARD**

Operating this vehicle with improper modifications.

**WHAT CAN HAPPEN**

Improper installation of accessories or modification of this vehicle may cause changes in handling which in some situations could lead to an accident.

**HOW TO AVOID THE HAZARD**

Never modify this vehicle through improper installation or use of accessories. All parts and accessories added to this vehicle should be approved by Bombardier and should be installed and used according to instructions. If you have questions, consult an authorized Bombardier ATV dealer.

Do not install passenger seats or use the racks to carry more than one passenger.

**⚠ WARNING**



V00A1UQ

**POTENTIAL HAZARD**

Overloading this vehicle or carrying or towing cargo improperly.

**WHAT CAN HAPPEN**

Could cause changes in vehicle handling which could lead to an accident.

**HOW TO AVOID THE HAZARD**

Never exceed the stated load capacity for this vehicle including operator and passenger, as well as other loads and added accessories.

Cargo should be properly distributed and securely attached.

Reduce speed when carrying cargo or pulling a trailer. Allow greater distance for braking.

Always follow the instructions in this *Operator's Guide* for carrying cargo or pulling a trailer.

 **WARNING**



V03M01Q

**POTENTIAL HAZARD**

Transporting inflammable or dangerous material can lead to explosions.

**WHAT CAN HAPPEN**

This can cause serious injury or death.

**HOW TO AVOID THE HAZARD**

Never transport inflammable or dangerous material.

While reading this *Operator's Guide*, remember that:

 **WARNING**

Indicates a potential hazard that, if not avoided, could result in serious injury or death.



---

## SAFETY WARNING

To fully appreciate the pleasures and excitement of riding this vehicle, there are some basic rules and tips that you should follow. Some may be new to you while others may be common sense or obvious. Irrespective, we ask that you take a few minutes to read this *Operator's Guide* completely before you operate this vehicle.

Information in this *Operator's Guide* is limited. It is strongly recommended that you obtain further information and training from your local authorities.

Bombardier does not recommend anyone under the age of 16 to drive this vehicle. The passenger should be 12 years old or more and should be able keep his feet on footrests and his hands on the grab handles at all time when seated on the vehicle. For the child's safety, we strongly recommend you also follow and enforce this recommendation. You are the sole judge of a rider's capability to understand the risks and operate a vehicle safely.

Persons with cognitive or physical impairments or are high risk takers have an increased exposure to overturns or collisions which may result in injury including death.

Become completely familiar with the operational controls and the general operation of the vehicle before venturing into off road conditions. Practice driving in a suitable area free of hazards and feel the response of each control before carrying a passenger. Drive at low speeds. Higher speeds requires greater experience, knowledge and suitable riding conditions.

The vehicle handling, stability and braking distance may be affected when riding with a passenger. Safely reduce speed when riding with a passenger. Allow greater distance for braking.

Not all vehicles are the same. Each has its own unique performance characteristics, controls and features. Each will ride and handle differently.

Never assume that the vehicle will go everywhere safely. Sudden changes in terrain caused by holes, depressions, banks, softer or harder "ground" plus others, may cause the vehicle to topple or become unstable. To avoid this, slow down and always observe the terrain ahead. If the vehicle does begin to topple or tipover, it is usually the best advice to immediately get off... AWAY from the direction of the tipover!

## Riding Tips

While reading this *Operator's Guide*, remember that:

### **WARNING**

Indicates a potential hazard that, if not avoided, could result in serious injury or death.

### **WARNING**

The pre-operation check is very important prior to operating the vehicle. Always check the proper operation of critical controls, safety features and mechanical components before starting. If not done, severe injury or death might occur.

Before using this vehicle, the operator should always:

- a) Disengage the parking brake.
  - b) Check the steering operation.
  - c) Test throttle operation.
  - d) Check brake functions.
  - e) Check engine cut-off switch function.
  - f) Verify operation and cleanliness of headlamp and taillight.
  - g) Verify fuel and oil levels.
  - h) Inspect tires and wheel rims for excessive wear or damage.
  - i) Check tire air pressure.
  - j) Secure all cargo and storage compartments.
  - k) Check backrest condition.
  - l) Check passenger grab handles condition.
  - m) Educate the passenger concerning the basic rules for a safety ride.
- Proceed only if all items are satisfactory.

# Clothing

Actual weather conditions should help you decide how to dress. However, it is important that the operator and the passenger always wear the appropriate protective clothing and apparel, including an approved helmet (with rigid chin guard for the passenger), eye protection, boots, gloves, long sleeved shirt and pants. Operator and passenger should never wear loose clothing such as a scarf that may get entangled in the vehicle or on tree shrubs and branches. Depending on conditions, a fog free visor or protective goggles may be required. This type of clothing will provide you protection from some of the minor hazards you may encounter on route. Sun glasses should only be worn during the daytime. Different colored lenses available for goggles or glasses help you distinguish terrain variations.

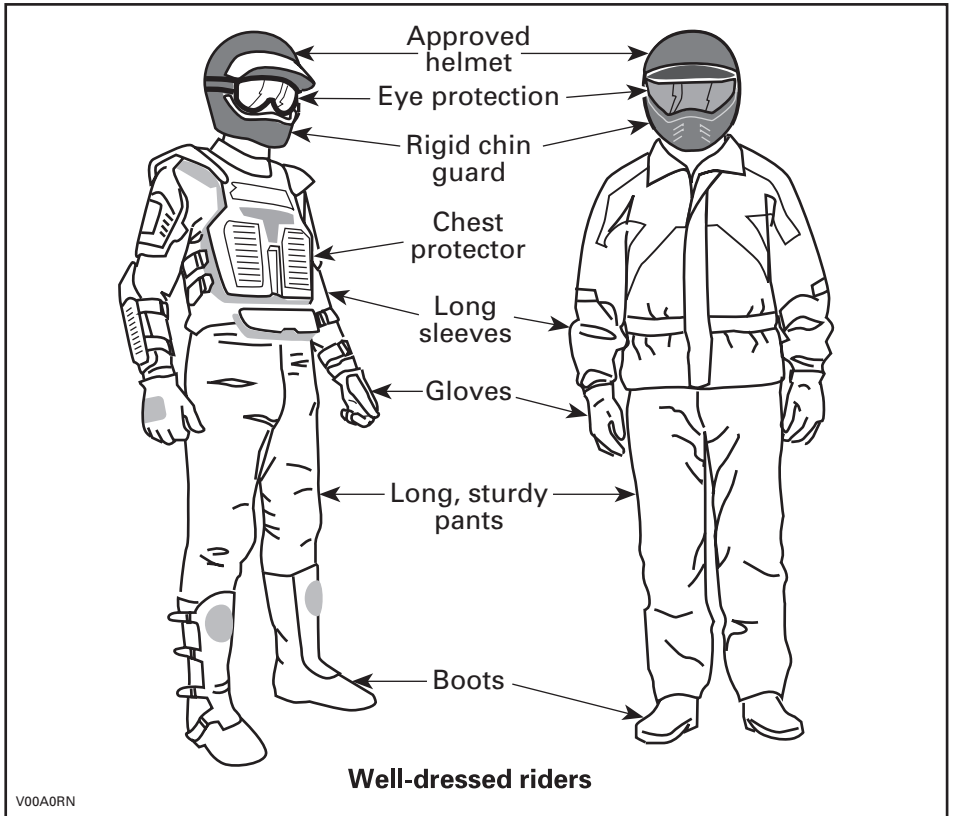

## **Carrying Loads/Passenger**

Any load carried on this vehicle's carrying rack(s) will affect the stability and control of the vehicle. For this reason, do not exceed the load limits of the vehicle manufacturer. Always make sure the load is secured and cannot interfere with your proper control. Always be aware that the "load" may slide or fall off and create an accident. Avoid loads that may protrude sideways and get snagged or caught in brush or other obstacles. Avoid covering and obstructing the headlamp or tail-lights with the cargo. Always make sure any storage compartment latches are closed. If a removable compartment cover is removed to carry a load, make sure that the load is secure and that smaller objects cannot "fly out". Secure compartment cover to the rear rack.

This vehicle is especially designed to carry an operator and ONE passenger only. Do not install other passenger seats or use the racks or their location to carry other passenger(s). Carrying more than one passenger may affect the stability and your control of the vehicle.

## **Hauling a Trailer**

Riding this vehicle with a trailer substantially increases the risk of toppling, especially on inclined slopes. If a trailer is used behind the vehicle make sure that its hitch is compatible with the one on the vehicle. Make sure the trailer is horizontal with the vehicle. (In some instances a special extension may have to be installed on the vehicle hitch). Use security chains to secure the trailer with the vehicle. This vehicle may require additional stopping distance if hauling heavy loads, especially on inclined surfaces and when a passenger is on board. Be careful not to skid or slide. When stopped or parked, block the vehicle and trailer wheels from possible movement. Always make sure load is evenly distributed on the trailer. Apply caution when disconnecting a loaded trailer, it or its load may topple on you or others. Do not turn at high speeds.

## **Working with your Vehicle**

Your vehicle can help you perform a number of different LIGHT tasks ranging from snow removal to pulling wood or carrying cargo. A variety of accessories are available from your authorized Bombardier ATV dealer. However, always respect the load and capacities of the vehicle. Overloading of the vehicle can overstress the components and cause failure. To prevent possible injury, it is equally important to follow the instructions and warnings that accompany the accessory. Avoid any physical exertion through lifting or pulling of heavy loads or manpowering the vehicle. (Continue to read RECREATIONAL RIDING below).

## Recreational Riding

Respect the rights and limitations of others. Stay away from areas designated for other types of off road use. This includes snowmobile trails, equestrian trails, cross country ski trails, mountain bike trails etc. Never assume there are no other users on the trail. Always stay to the complete right of the trail and do not zig zag to one side of the trail then the other. Be prepared to stop or pull off to the side if another trail user appears in front of you.

Always keep a safe distance from other riders. Your judgment of speed, terrain conditions, weather, mechanical condition of your vehicle and the "trust in judgment" you have in others around you will help you make a better choice of appropriate safe distance. This vehicle, like any other motorize vehicle, cannot stop "on a dime". The vehicle handling, stability and braking distance may be affected when riding with a passenger. Safely reduce speed when riding with a passenger. Allow greater distance for braking.

Always operate this vehicle at low speed, do not exceed 65 km/h (40 MPH), and reduce the speed before taking a turn when the vehicle is operated on the roadway.

Before you ride, tell someone where you are planning to travel and your expected time of return. Never consume alcohol or drugs before or while riding!

Depending on the length of your ride, carry additional tools or emergency equipment. Find out where you can get additional gasoline and oil. Be prepared for the possible conditions you may encounter. An emergency first aid kit should always be a consideration.

## Environment

One of the benefits of this vehicle is that it can take you off the beaten path away from most communities. However, you should always respect nature and the rights of others to enjoy it. Do not ride in environmentally sensitive areas. Do not drive over crops or tree shrubs... nor cut down trees or take down fencing... nor spin your wheels and destroy the terrain. "Tread Lightly".

Chasing wildlife is in many areas illegal. Wildlife can die of exhaustion after being chased by a motorize vehicle. If you encounter animals on the trail, stop and observe quietly and with caution. It will be one of the better memories of your life.

Observe the rule... "what you take in, carry out". Do not litter. Do not start campfires unless you have permission to do so... and only then... away from dry areas. The hazards you may create on the trail may cause injury to others or yourself, even at a later date.

Respect farm lands. Always obtain the permission of the landowner before riding on private land. Respect crops, farm animals and property lines. If you come to a closed a gate, close it again behind you.

Finally, do not pollute streams, lakes or rivers and do not modify the engine or muffling system, or remove any of its components.

## Design Limitation

Although the vehicle is exceptionally rugged for its class, it is still a light vehicle by definition and its operation must be restricted to its proper purpose.

The addition of weight to any part of the vehicle changes its gravitational stability and modifies its performance.

## Off-Highway Operation

The very nature of off-highway operation is dangerous. Any terrain, which has not been specially prepared to carry vehicles, presents an inherent danger where angularity, terrain substance and exact steepness are unpredictable. The terrain itself presents a continual element of danger, which must be knowingly accepted by anyone venturing over it.

An operator who takes a vehicle off-road should always exercise the utmost care in selecting the safest path and keeping close watch on the terrain ahead of him. On no account should the vehicle be operated by anyone who is not completely familiar with the driving instructions applicable to the vehicle, or should it be operated on steep or treacherous terrain.

## General Operating and Safety Precautions

Care, caution, experience and driving skill are the best precautions against the hazard of vehicle operation.

Whenever there is the slightest doubt that the vehicle can safely negotiate an obstacle of a particular piece of terrain, always choose an alternate route.

In off-road operation, power and traction, not speed, are important. Never drive faster than visibility and your own ability to select a safe route permits.

Constantly watch the terrain ahead for sudden changes in slopes or obstacles, such as rocks or stumps, that may cause loss of stability, resulting in tip-over or roll-over.

The vehicle handling, stability and braking distance may be affected when riding with a passenger. Safely reduce speed when riding with a passenger. Allow greater distance for braking.

Never operate the vehicle if the controls do not function normally.

For the users in the European Community, the winch hook removal is compulsory to operate the vehicle on the roadway. Failure to follow this recommendation could cause additional injuries including the possibility of death if an accident occurs.

While reading this *Operator's Guide*, remember that:

### **WARNING**

Indicates a potential hazard that, if not avoided, could result in serious injury or death.

## **Uphill Driving**

Due to configuration, this vehicle have excellent climbing ability, so much so that tip-over is possible before traction is lost. For example, its common to encounter terrain situations where the top of the hill has eroded to a point that the hill peak rises very sharply. The vehicle can readily negotiate such a condition, however, in doing so, when the front of the vehicle is driven to a point that the vehicle's balance changes rearward tip over can occur.

The same situation may apply if an embedded object causes the front of the vehicle to climb more than desired. If such a situation occurs take an alternate route. Be aware of sidehilling dangers when doing so.

It is also wise to know the terrain condition on the other side of the hill or bank. All too often there exists a sharp drop-off that is impossible to negotiate or descend.

## **Downhill Driving**

This vehicle can climb slopes that are steeper than they can safely descend. Therefore, it is essential to assure that a safe route exists to descend a slope before you climb it.

Decelerating while negotiating a slippery downhill slope could “toboggan” the vehicle. Maintain steady speed and/or accelerate slightly to regain control.

## **Side Hilling**

Whenever possible, such operation should be avoided. If necessary, do so with extreme caution. Always disembark the passenger before performing this operation. Sidehilling on steep inclines could result in roll-over. In addition, slippery or unfirm surfaces could result in uncontrollable side sliding. Do not attempt to turn the vehicle downhill with the slide. Avoid all objects or depressions that will intensify the raising of one side of the vehicle higher than the other, thus causing roll-over.

## **Drop-Offs**

This vehicle will “bottom-out” and usually stop if either the front or rear wheels are driven over a drop-off. If the drop is sharp or deep, the vehicle will nose dive and tip-over.

### **WARNING**

**Avoid negotiating drop-offs. Reverse and select an alternate route.**

## Riding Techniques

Riding your vehicle too fast for the conditions may result in injury. Apply only enough throttle to proceed safely. Statistics show that high speed turns usually result in mishaps and injury. Always remember that this vehicle is heavy! It's pure weight alone may entrap you should it fall and pin you down.

This vehicle is not designed for jumping nor can it, or you, absorb the energy of high impacts such as jumping. Performing "wheelies" can cause the vehicle to flip over onto you. Both practices have a high risk for you and your passenger and should be avoided at all times.

To maintain proper control it is strongly advised that you keep your hands on the handlebar and within easy reach of all controls. The same holds true for your feet. To minimize the possibility of any leg or foot injury, keep your feet on the footrests at all times. Do not direct your toes outwards nor place your foot out to assist turning as they can be hit or snagged by passing obstacles or may contact the wheels. Your passenger must also keep his hands on grab handles and his feet on footrests at all times.

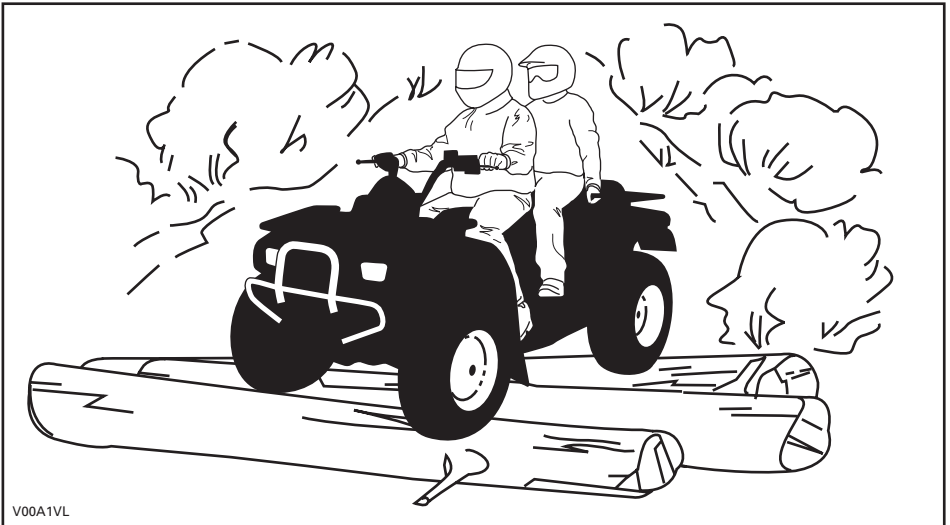

Even though there is an adequate suspension system on this vehicle there are "washboard" or rough terrain conditions that will make you feel uncomfortable and even cause back injury. "Posting" or riding in a crouched position will often be required. Slow down and allow your flexed legs to absorb impact.

If a road usage is allowed in your area, operate your vehicle on paved surface only for short distance and for the only purpose of moving the vehicle from an off-road usage to another. Always operate your vehicle at low speed (never exceed 65 km/h (40 MPH)) and reduce the speed before making a turn. Always respect all road traffic laws when operating your vehicle on public roads or streets. If you have to cross a road, the lead driver should get off his vehicle then observe and give directions to the other riders. The last person after crossing then assists the lead driver to cross. Do not travel on sidewalks. They are designated for pedestrian use.



Water can be a unique hazard. If it is too deep the vehicle may “float” and topple. Check the water depth and current before you attempt to cross any water. Water should not go above the footrest. Be wary of slippery surfaces such as rocks, grass, logs, etc., both in the water and on its banks. A loss of traction may occur. Do not attempt to enter the water at high speed. The water will act as a brake and could throw you.

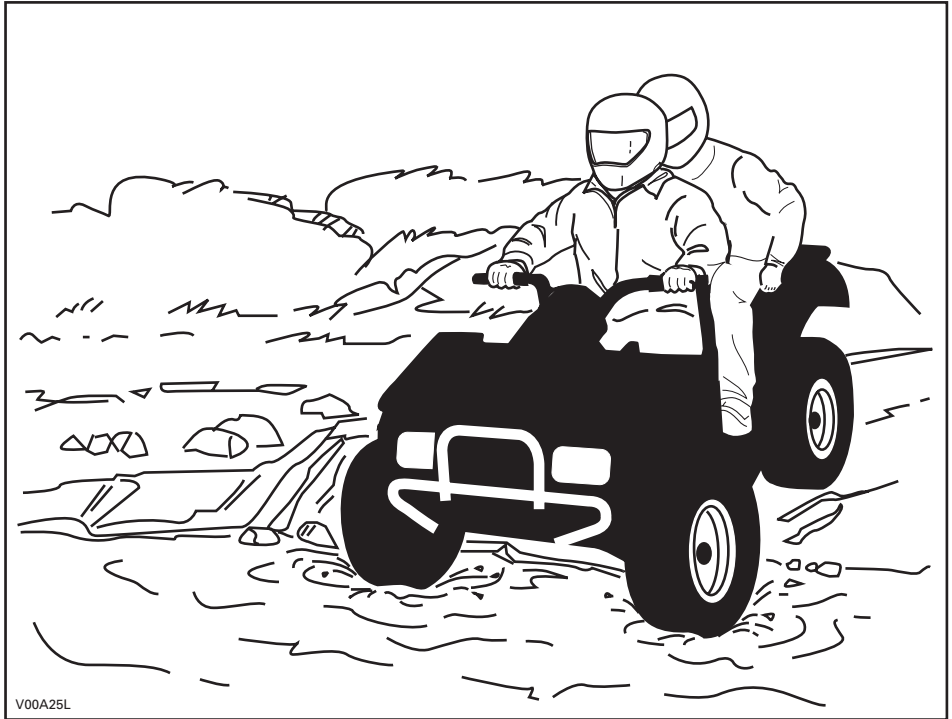

V00A25L

Water will affect the braking ability of your vehicle. Make sure you dry the brakes by applying them several times after the vehicle leaves the water. The vehicle braking distance may be affected when riding with a passenger. Safely reduce speed when riding with a passenger. Allow greater distance for braking.

Mud or marsh lands may be encountered near water. Be prepared for sudden “holes” or change in depth. Similarly so, be watchful of hazards such as rocks, logs, etc., partially covered by vegetation.

If your trip crosses frozen waterways, make sure that **the ice is thick enough and sound enough** to support the total weight of yourself, your passenger, the vehicle and its load. Be ever watchful of open water... it is a sure indication that the ice thickness will vary. The operator is responsible for the safety of his passenger. If in doubt, do not attempt to cross.

Ice will also affect the control of vehicle. Slow down and do not “gun” the throttle. This will only result in spinning of the tires and possible tipover of the vehicle. Avoid rapid braking. This again will possibly result in an uncontrolled slide and tipover of the vehicle or passenger ejection. Slush should be avoided at all times since it could block the operation or controls of the vehicle. Never attempt this maneuver with a passenger. Always remember that the vehicle handling and stability may be affected when riding with a passenger.

Sand and riding on sand dunes or on snow is another unique experience but there are some basic precautions that should be observed. Wet, deep or fine sand/snow may create a loss of traction and cause the vehicle to slide, drop off or become “bogged” down. If this occurs look for a firmer base. Again, the best advice is to slow down and be watchful of the conditions. When you ride with a passenger, drive slowly.

When riding in sand dunes it is advisable to equip the vehicle with an antenna type safety flag. This will help make your location more visible to others over the next sand bank. Proceed carefully should you see another safety flag ahead. Since the antenna type safety flag can snag and rebound on your body if caught, do not use it in areas where there are low hanging branches or obstacles. Always remember that the vehicle handling and stability may be affected when riding with a passenger.

Loose stones or gravel are very similar to riding on ice. It will affect the steering of vehicle... causing it to possibly slide or cause passenger ejection and tipover especially at high speeds. In addition, braking distance may be effected. Remember that “gunning” the throttle or sliding may cause loose stones to be ejected rearwards into the path of another rider. Never do it deliberately. Always remember that the vehicle handling, stability and braking distance may be affected when riding with a passenger.

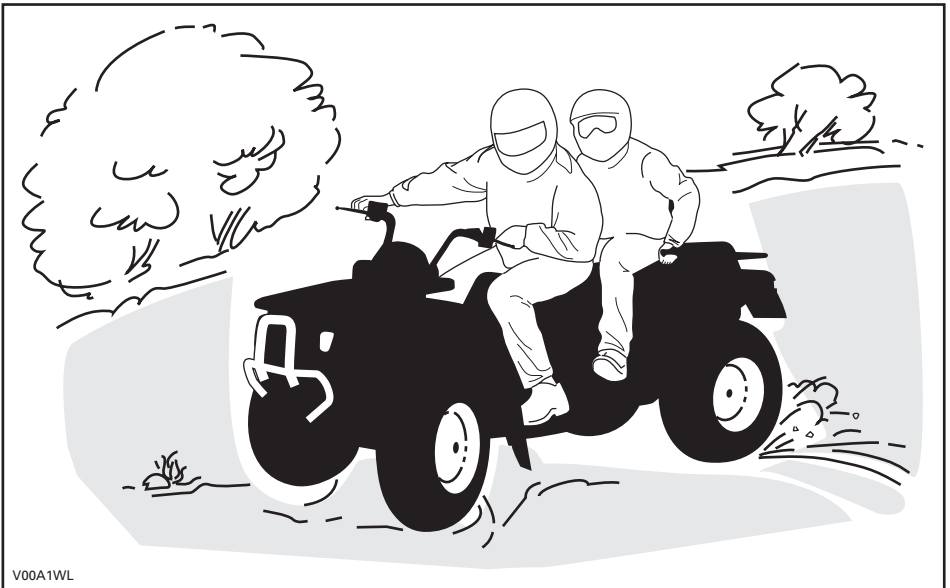

If you do get into a slide or skid, it may help to turn the handlebar into the direction of the skid until you regain control. Never jam the brakes and lock the wheels.

Respect and follow all posted trail signs. They are there to help you and others.

Obstacles in the "trail" should be traversed with caution. This includes loose rocks, fallen trees, slippery surfaces, fences, posts, and embankments and depressions. You should avoid them whenever possible. Remember that some obstacles are too large or dangerous to cross and should be avoided. The operator is responsible for the safety of the passenger and in doubt, disembark the passenger before getting through the obstacles. Small rocks or fallen trees may be safely crossed... approach at a 90° angle. Stand on the footrests while keeping your knees flexed. Adjust speed without losing momentum and do not "gun" the throttle. Hold handgrips firmly. Operator and passenger must place their body weight rearwards and proceed. Do not try to lift the vehicle front wheels off the ground. Be aware that the object may be slippery or may move while crossing.

When driving on hills or slopes two things are highly important... be prepared for slippery surfaces or terrain variations and obstacles and... use proper body positioning. The operator is responsible for the safety of his passenger and in doubt, disembark the passenger before getting through the obstacles.

## **Uphill**

Do not forget, the operator is responsible for the safety of the passenger. In doubt, disembark the passenger before climbing hill. Always remember that the vehicle handling, stability and braking distance may be affected when riding with a passenger.

If you decide to keep your passenger, the passenger must synchronize its movements with yours.

Operator and passenger must keep their body weight forward towards the top of the hill. Keep your feet on the footrests and shift into low gear then accelerate and when necessary, change gear quickly as you climb. Do not over-speed since this may cause the front of the vehicle to lift from the ground and fall back on you. If the hill is too steep and you cannot proceed or the vehicle begins to roll backwards, apply the brake, being careful not to slide. Dismount, passenger first, then use the "K" turn or "U" turn (While walking back, next to the vehicle on the up hill side and with a hand on the brake lever, slowly back the rear of the vehicle toward the top of the hill then drive downhill). Always walk or dismount on the upside of the slope while keeping clear of the vehicle and its rotating wheels. Do not try to hold on to the vehicle if it begins to toppling. **Stay clear.** Do not ride over the crest of the hill at high speed. Obstacles, including sharp drop-offs, may exist. The passenger should get on the vehicle only when the vehicle will be returned to a safe location.

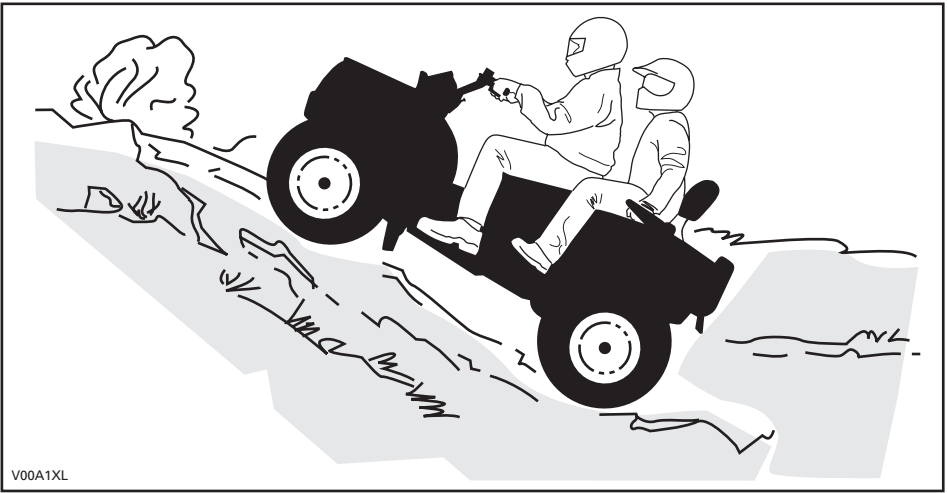

## Downhill

Do not forget, the operator is responsible for the safety of the passenger. In doubt, disembark the passenger before climbing hill. Always remember that the vehicle handling, stability and braking distance may be affected when riding with a passenger.

If you decide to keep your passenger, the passenger must synchronize its movements with yours.

Operator and passenger must keep their body weight rearwards. Apply the brake gradually to prevent skidding. Do not "coast" down the slope using solely engine compression or in neutral gear.

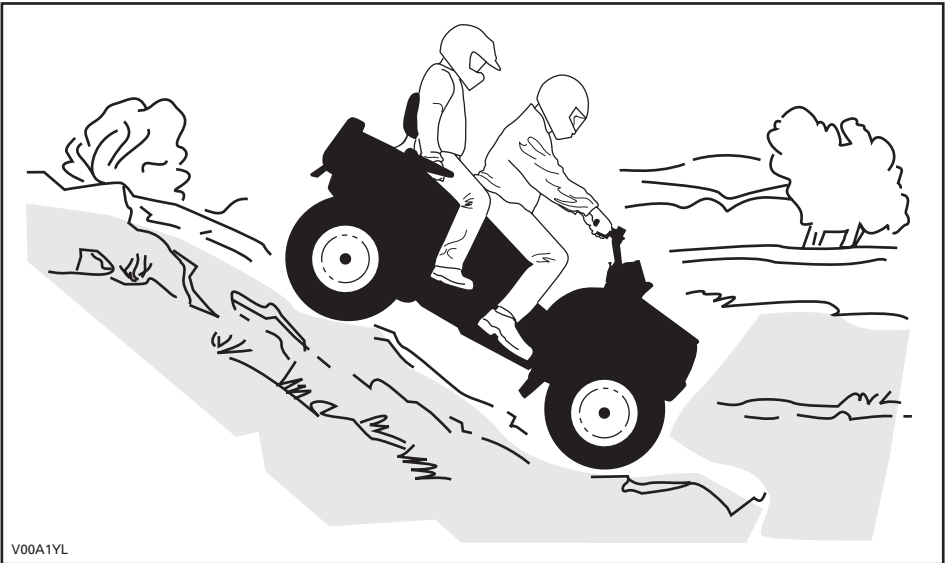

## Sidehilling

Do not forget, the operator is responsible for the safety of the passenger. In doubt, disembark the passenger before climbing hill. Always remember that the vehicle handling, stability and braking distance may be affected when riding with a passenger.

If you decide to keep your passenger, the passenger must synchronize its movements with yours.

This is one of the **most risky** types of riding since it may drastically change the balance of the vehicle. It should be avoided wherever possible. If it is necessary to do so however, it is important that you and your passenger **ALWAYS** keep your body weight on the upside of the slope... and be prepared to dismount on that side should the vehicle begin to topple. **Do not try to stop or save the vehicle from damage.**



When operating in reverse, check that the path behind the vehicle is free of people or obstacles. Proceed slowly and avoid any sharp turns. Take into account that the passenger can obstruct your view. Disembark your passenger if necessary.

When stopped or parked always apply the parking brake. This is especially important when parking on a slope. On very steep inclines or if the vehicle is carrying a cargo, the wheels should be blocked using rocks or bricks. Remember to turn the fuel valve to the closed position.

## Routine Maintenance

Once completing your ride it is wise to remove any build up of snow, ice, mud and grime. Not only will this help you keep your vehicle longer and in good condition for resale but will eliminate potential hazards the next time you use the vehicle. Wash your vehicle in warm soapy water then allow it to dry. (A towel may help). Do not wash your vehicle outside during freezing weather. Apply appropriate lubrication as described in the MAINTENANCE section.

Part of your responsibility towards safety is to respect the contents of this *Operator's Guide*. It provides valuable advise on how to properly take care of your vehicle. If further assistance is required your authorized Bombardier ATV dealer is always willing to help.

Modification of the vehicle to increase speed and performance may violate the terms and conditions of your vehicle limited warranty. In addition, certain modifications including the removal of engine or exhaust components are illegal under most laws.

Changing the wheel and/or tire size may affect the stability of the vehicle. Incorrect tire pressure may lead to blow outs or cause a tire to move around on its rim and become lost or damaged. Wheels or tires which are damaged should always be replaced.

The vehicle handling, stability and braking distance may be affected when riding with a passenger. Safely reduce speed when riding with a passenger. Allow greater distance for braking.

The operator is responsible for the safety of the passenger. In doubt, disembark the passenger executing the maneuver. Use your common sense.

While reading this *Operator's Guide*, remember that:

### **WARNING**













Indicates a potential hazard that, if not avoided, could result in serious injury or death.

# HANG TAG

This vehicle comes with a hang tag and labels containing important safety information.

The labels should be considered as permanent parts of the vehicle. If a label comes off or becomes hard to read, please contact an authorized Bombardier ATV dealer for replacements.

Any person who rides this vehicle should read and understand this information before riding.

<p><b>⚠ WARNING</b></p> <p>Improper vehicle use can result in SEVERE INJURY or DEATH.</p> <table border="0"><tr><td></td><td></td><td></td><td></td></tr></table> <p>ALWAYS USE AN APPROVED HELMET AND PROTECTIVE GEAR FOR DRIVER AND PASSENGER.</p> <p>NEVER USE ON PUBLIC ROADS.</p> <p>NEVER CARRY MORE THAN 1 PASSENGER.</p> <p>NEVER USE WITH DRUGS OR ALCOHOL.</p> <p><b>NEVER operate:</b></p> <ul style="list-style-type: none"><li>• without proper training or instructions.</li><li>• at speeds too fast for your skills or the conditions.</li><li>• on public roads - a collision can occur with another vehicle.</li></ul> <p><b>ALWAYS:</b></p> <p>use proper riding techniques to avoid vehicle overturns on hills and rough terrain and in turns.</p> <p>avoid paved surfaces - pavement may seriously affect handling and control.</p> <p>LOCATE AND READ OPERATOR'S GUIDE. FOLLOW ALL INSTRUCTIONS &amp; WARNINGS.</p> <p>This hangtag is not to be removed before sale.</p> <p>V01M0WL <span style="float: right;">7049C0628</span></p>					<p><b>2-UP ATV</b></p> <p><b>NO OPERATOR UNDER AGE 16</b></p> <p><b>NO PASSENGER UNDER AGE 12</b></p> <p><b>NEVER CARRY MORE THAN ONE PASSENGER</b></p> <hr/> <p><b>THIS VEHICLE IS FOR OFF ROAD USE ONLY.</b></p> <hr/> <p>TRAINING COURSES TO TEACH RIDING SKILLS ARE PROVIDED WITH THIS VEHICLE. MAKE SURE TO WATCH THE THE SAFETY VIDEO. READ AND UNDERSTAND THE OPERATOR'S MANUAL AND ALL OF THE WARNING LABELS ON THIS VEHICLE BEFORE OPERATING.</p> <hr/> <p>CHECK WITH YOUR DEALER TO FIND OUT ABOUT STATE OR LOCAL LAWS REGARDING VEHICLE OPERATION.</p> <p>This hangtag is not to be removed before sale.</p>
					

While reading this *Operator's Guide*, remember that:

## **⚠ WARNING**

Indicates a potential hazard that, if not avoided, could result in serious injury or death.

# LOCATION OF THE IMPORTANT LABELS

The following labels are on your vehicle. If missing or damaged, they can be replaced free of charge. See an authorized Bombardier ATV dealer.

**NOTE:** The following illustrations used in this *Operator's Guide* are a general representation only. Your model may differ.

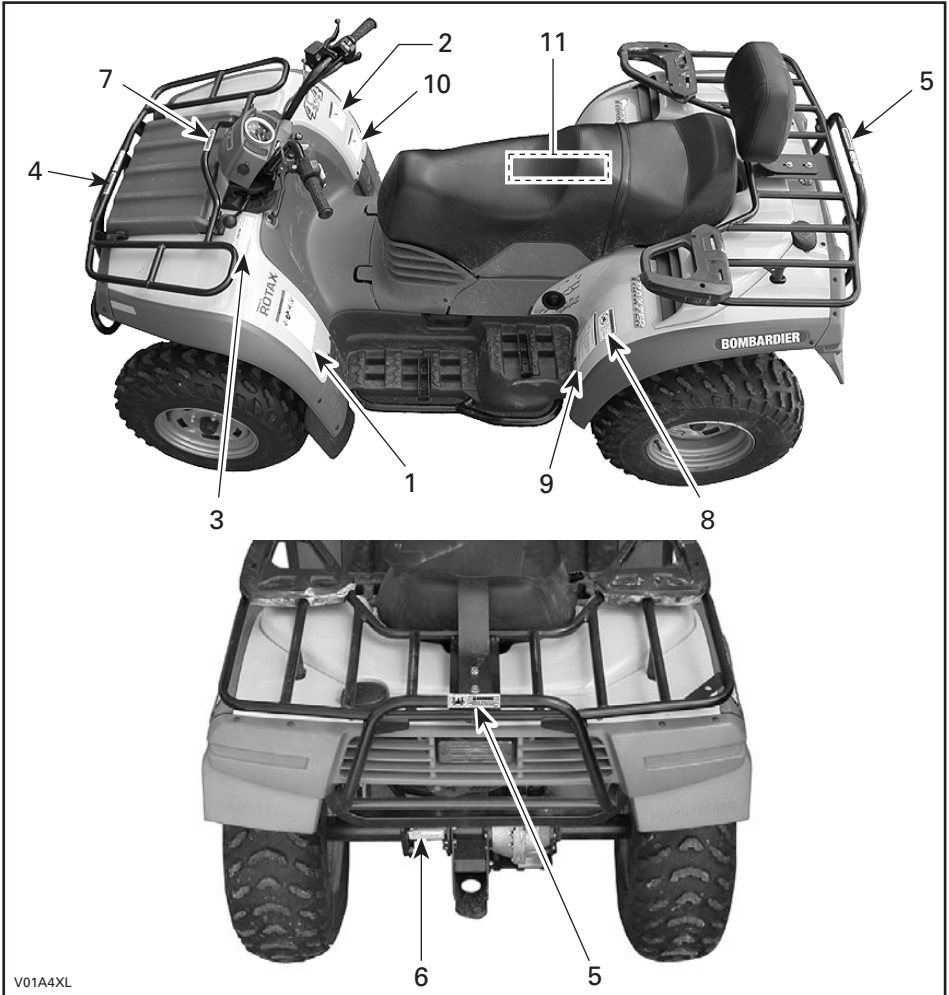

V01A4XL

TYPICAL



## Label 1

**⚠ WARNING**

Improper vehicle use can result in **SEVERE INJURY** or **DEATH**.



**ALWAYS USE AN APPROVED HELMET AND PROTECTIVE GEAR FOR DRIVER AND PASSENGER.**

**NEVER USE ON PUBLIC ROADS.**

**NEVER CARRY MORE THAN 1 PASSENGER.**

**NEVER USE WITH DRUGS OR ALCOHOL.**

**NEVER operate:**

- without proper training or instructions.
- at speeds too fast for your skills or the conditions.
- on public roads - a collision can occur with another vehicle.

**ALWAYS:**

use proper riding techniques to avoid vehicle overturns on hills and rough terrain and in turns.

avoid paved surfaces - pavement may seriously affect handling and control.

**LOCATE AND READ OPERATOR'S GUIDE. FOLLOW ALL INSTRUCTIONS & WARNINGS.**

704 900 451

V01M0QY

## Label 2

**⚠ WARNING**

**OPERATOR UNDER 16**

Operating this vehicle if you are under age 16 increases the chance of **SEVERE INJURY** or **DEATH** to both rider and passenger.

**NEVER** operate this vehicle if you are under age 16.

**NEVER** carry more than one passenger.

704 900 515

V01M0RY

## Label 3

**CAUTION**

- **ATV MUST** be stopped before shifting transmission lever.
- Always apply foot brake to shift from **PARK (P)**.

704 900 007

V01M03Z

## Label 4



**⚠ WARNING**

**NEVER** carry a passenger on this carrier.

**MAXIMUM FRONT LOAD:** 90 lbs (40 kg) evenly distributed. (Includes front storage tray load: 22 lbs (10 kg))

704 900 913

V01M0SY

## Label 5



**⚠ WARNING**

**NEVER** carry a passenger on this carrier.

**MAXIMUM REAR LOAD:** 175 lbs (80 kg) evenly distributed. (Includes trailer tongue weight if applicable.)

704 900 917

V01M0TY

## Label 6

**⚠ WARNING**

Improper loading of a trailer may cause loss of vehicle control.

- Maximum towing weight: **1100 lb (500 kg)**.
- Maximum tongue weight: **30 lb (14 kg)**.

704 900 009

V01M06Z

## Label 7

**⚠ WARNING**

**Always latch storage cover.**

704 900 038

V01M0BZ

## Label 8

**⚠ WARNING**

Improper vehicle use can result in  
**SEVERE INJURY or DEATH.**



**PASSENGER  
UNDER  
12**

**NEVER CARRY  
A PASSENGER  
UNDER AGE 12.**



**NEVER CARRY  
MORE THAN  
1 PASSENGER.**

**NEVER:**

- carry a passenger under age 12.
- carry more than one passenger.
- carry a passenger too small to firmly plant feet on footrests and securely grab handles.

704 900 516

V01M0UY

## Label 9

**⚠ WARNING**

Improper tire pressure or overloading can cause loss of control.  
Loss of control can result in **SEVERE INJURY or DEATH.**

LOAD	COLD TIRE PRESSURE
UP TO 640 lbs (290 kg)	FRONT MAX : 7 psi, 48 kPa MIN : 5 psi, 35 kPa  REAR MAX : 7 psi, 48 kPa MIN : 5 psi, 35 kPa

**ALWAYS** maintain proper tire pressure as shown.  
**NEVER** exceed the vehicle load capacity of 640 lbs (290 kg)  
Includes weight of operator, passenger, cargo, and accessories  
(and if applicable, trailer tongue weight).

**LOADING / TRAILER TOWING**

- Cargo or trailer can affect stability and handling.
- When loading with cargo or towing a trailer
  - reduce speed.
  - allow more room to stop.
  - avoid hills and rough terrain.

704900519

V01M0VY

## Label 10

**⚠ WARNING**

**This warning applies only in European  
Countries where on road usage is allowed.**

**On Road Use**

This ATV is built for "OFF ROAD" purposes only.  
It may be used for short distances on paved surfaces  
at reduced speed, in order to move the vehicle from  
an off road location to another.

When driving this ATV on roads, always refrain from  
speeding and substantially reduce vehicle speed  
when turning.

Failure to do so can cause a loss of vehicle control,  
possibly resulting in serious injury or death.

**Front Winch**

The front winch hook of the so equipped ATV's must  
be removed and stored when riding the vehicle on  
public trails and/or roads.

Failure to do so can increase the risk of injury to  
bystanders.

704 900 400

V01M0PY

# Label 11

<b>VEHICLE EMISSION CONTROL INFORMATION</b>	<b>ENGINE FAMILY:</b> 3BCXX.4982GC <b>EXHAUST EMISSION CONTROL SYSTEM:</b> EM <b>DISPLACEMENT:</b> 497.70cc <b>TUNE-UP SPECIFICATIONS:</b>		<b>BOMBARDIER</b> <i>RECREATIONAL PRODUCTS</i>	
	<b>IDLE SPEED:</b>	1100 RPM $\pm$ 100 RPM		
	<b>IDLE AIR/FUEL MIXTURE SETTING:</b>	FROM POSITION OF PILOT SCREW FOR MAXIMUM SPEED AT IDLE, UNSCREW 3/8 OF TURN		
	<b>SPARK PLUG:</b> <b>FUEL: (RON + MON) /2</b> <b>ENGINE OIL:</b>	NGK DR8EA ELECTRODE GAP $\rightarrow$ 0,6 mm - 0.7 mm UNLEADED 87 OCTANE SAE 10W40		
<b>THIS VEHICLE CONFORMS TO CALIFORNIA REGULATIONS APPLICABLE TO 2003 MODEL YEAR NEW OFF-ROAD MOTORCYCLES AND ALL TERRAIN VEHICLES AND IS CERTIFIED TO 10 g/bhp-hr HC+NOx ENGINE FAMILY EXHAUST EMISSION STANDARD.</b>				
V01MOOL				704 900 314



# ***VEHICLE INFORMATION***

# HOW TO IDENTIFY YOUR VEHICLE

The main components of your vehicle (engine and frame) are identified by different serial numbers. It may sometimes become necessary to locate these numbers for warranty purposes or to trace your vehicle in the event of loss. These numbers are required by the authorized Bombardier ATV dealer to complete warranty claims properly. No warranty will be allowed by Bombardier Inc. if the engine identification number (EIN) or vehicle identification number (VIN) is removed or mutilated in any way. We strongly recommend that you take note of all the serial numbers on your vehicle and supply them to your insurance company.

## Engine and Vehicle Identification Number Location

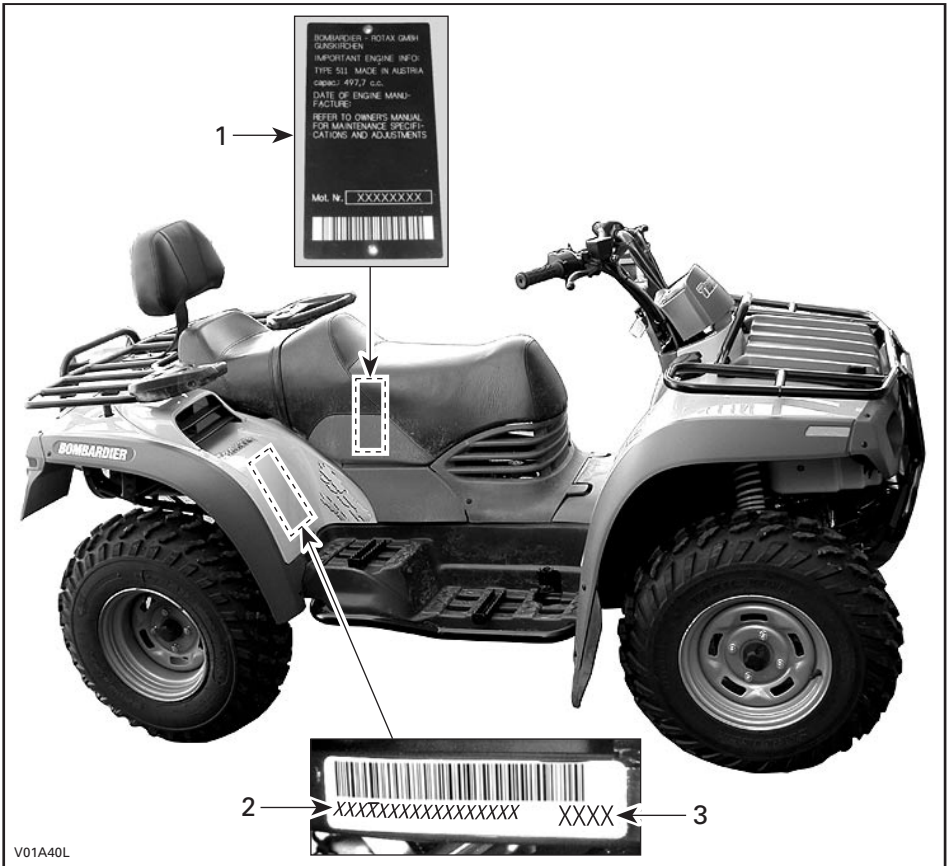

### TYPICAL

1. EIN (Engine Identification Number)
2. VIN (Vehicle Identification Number)
3. Model

# CONTROLS/INSTRUMENTS/EQUIPMENTS

NOTE: Some controls/instruments/equipments do not apply to this model. In these cases their reference numbers are deliberately missing in the illustrations. Some controls/instruments/equipments are optional on this model.

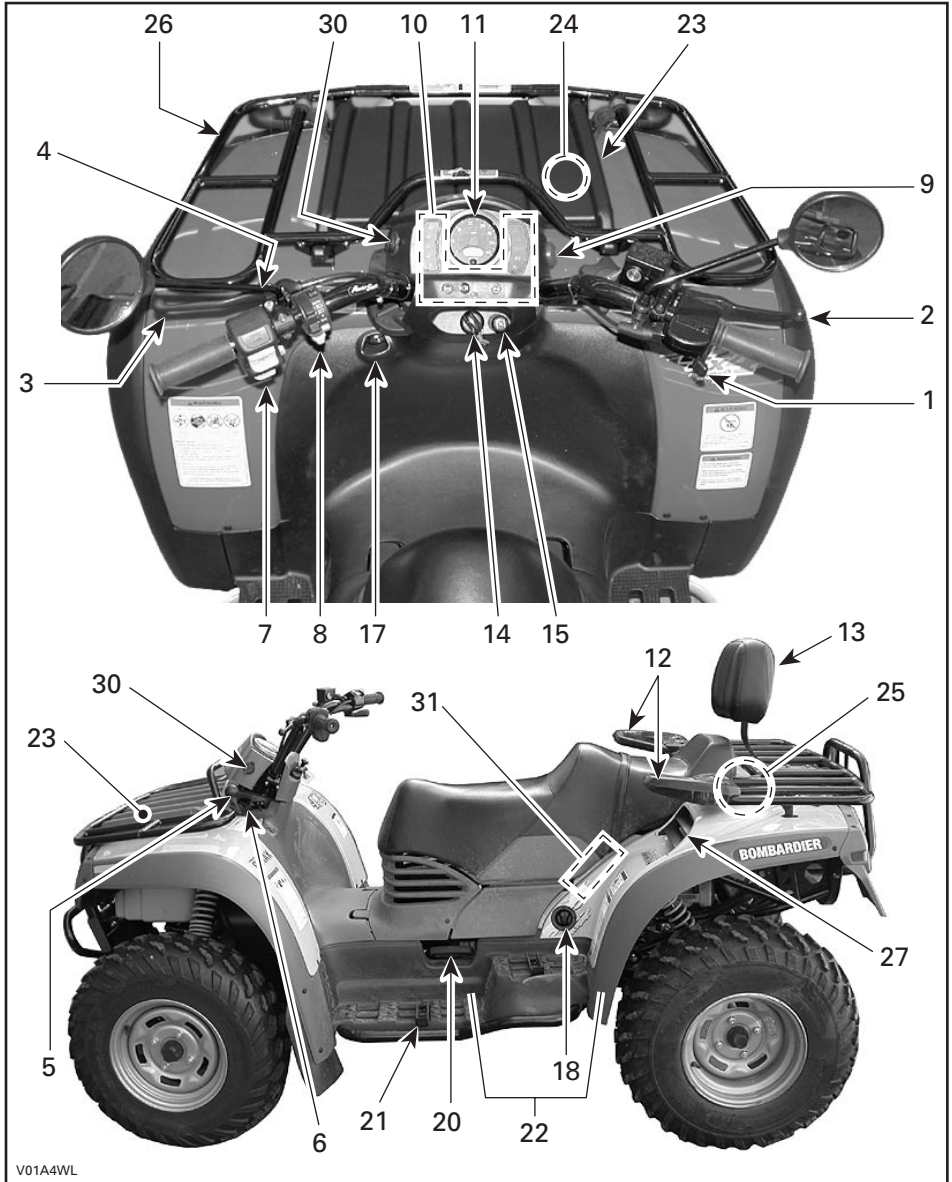

V01A4WL

TYPICAL

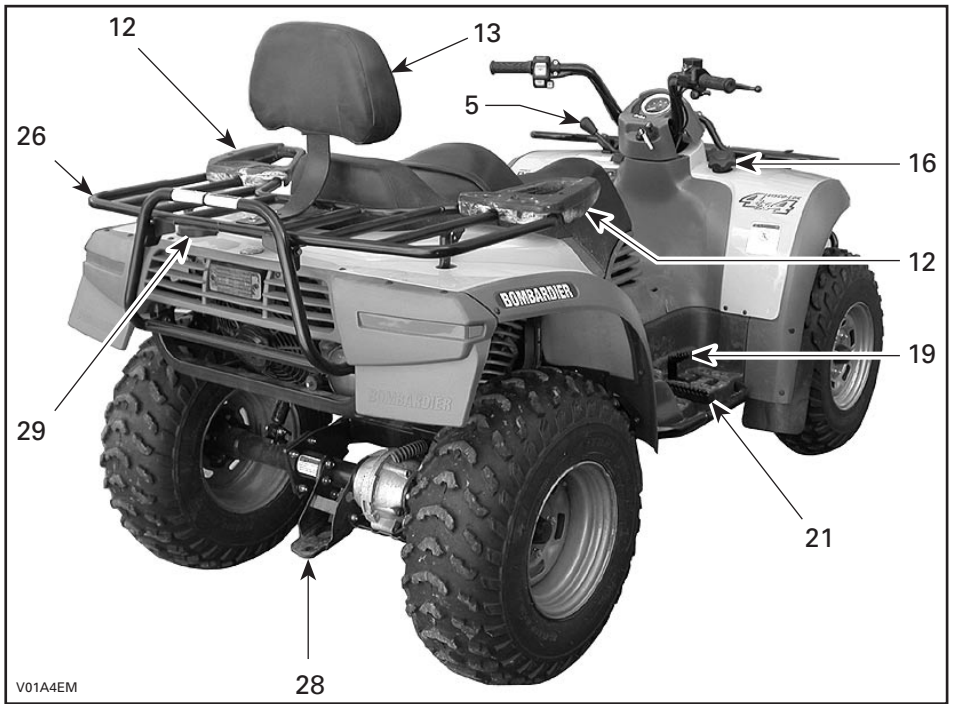

V01A4EM

TYPICAL



While reading this *Operator's Guide*, remember that:

## **WARNING**

Indicates a potential hazard that, if not avoided, could result in serious injury or death.

**NOTE:** This section gives basic functions of the various controls of your vehicle. For more details of how to operate one control in conjunction with some others, refer to OPERATING INSTRUCTIONS in this *Operator's Guide*.

### **1) Throttle Lever**

Located on the right side of handlebar. When pushed, it increases the engine speed that allows the engagement of the transmission on the selected gear. When released, the engine speed should return automatically to idle and the vehicle will gradually slow down.

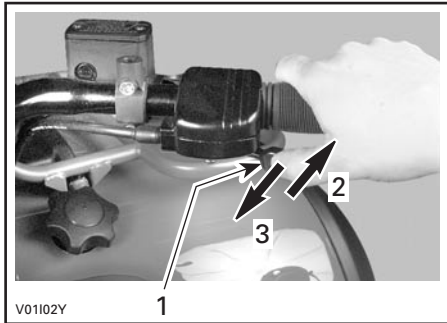

1. *Throttle lever*
2. *To accelerate*
3. *To decelerate*

### **2) Front Brake Lever**

Located on the right side of handlebar. When compressed, the brake is applied. When released, it should automatically return to its original position. Braking effect is proportional to the force applied on the lever and to the type and condition of the terrain. The front brake will have also an effect on rear wheels through the drive train.

See the note at REAR BRAKE LEVER below for additional information.

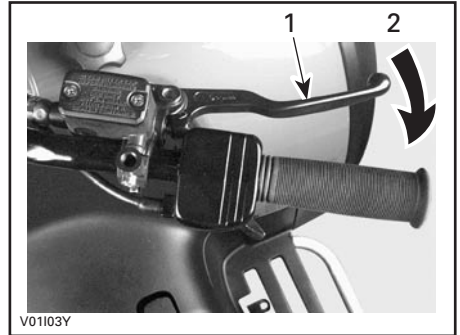

1. *Brake lever*
2. *To apply brake*

### **3) Rear Brake Lever**

Located on the left side of handlebar. When compressed, the brake is applied. When released, it should automatically return to its original position. Braking effect is proportional to the force applied on the lever and to the type and condition of the terrain.

**NOTE:** Using the rear brake will have also an effect on front wheels because they are interconnected through the drive train. As on other wheeled vehicles, the vehicle weight is transferred to the front wheels when braking. To obtain greater stopping efficiency, the brake system distributes more braking force to the front wheels. This will affect vehicle handling and steering control when braking vigorously. Take it into account when braking.

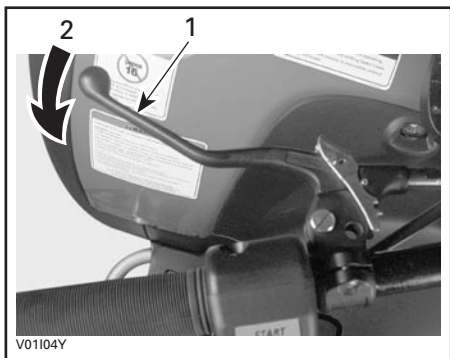

1. Brake lever
2. To apply brake

#### 4) Brake Lever Lock

Located on left side of handlebar on rear brake lever. When applied, it prevents the vehicle from moving. Useful when the brake needs to be locked for example such as doing a K-turn.

#### **⚠ WARNING**

Always use the brake lever lock **and** engage the PARK position on the transmission lever when the vehicle is not in operation.

#### **⚠ WARNING**

Make sure brake lever lock is fully disengaged before operating the vehicle.

When you ride the vehicle, brakes that are caused to drag by a continuous pressure on the lever may cause damage to the brake system and cause loss of braking capacity and/or fire.

**To engage mechanism:** Squeeze brake lever and maintain while moving lever lock with a finger. Brake lever is now compressed and applying rear brake.

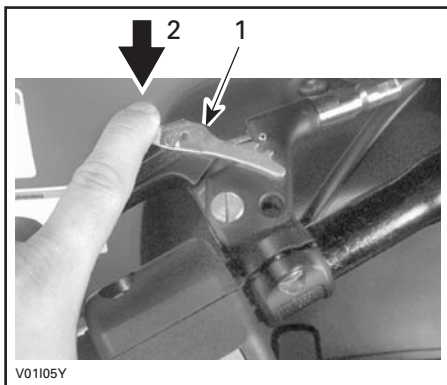

1. Brake lever lock
2. Press to apply parking brake

**To release mechanism:** Squeeze brake lever. Lever lock should automatically return to its original position. Brake lever should return to rest position. Always release brake lever lock before riding.

#### 5) Transmission Lever

Located on the left side of steering column. A 5-position lever: P, R, N, H and L.

To change the transmission position, completely stop vehicle then move lever to the desired position while pulling lever upward. Do not force lever. If unable to shift, gently apply throttle to move the vehicle and try again.

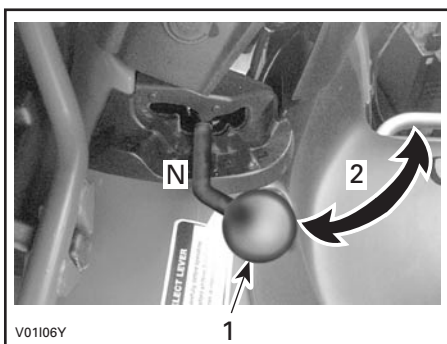

1. Transmission lever
2. To change position

**CAUTION:** Always completely stop the vehicle and apply the brake prior to moving the transmission lever.

**P: Park**

This position locks the transmission to help prevent vehicle movement. Always use when the vehicle is not in operation. In some circumstances, it may be necessary to rock the vehicle back and forth to move the gears in the transmission to allow the park to be engaged.

**R: Reverse**

This allows the vehicle to go backward. The vehicle speed is limited.

**⚠ WARNING**

Before moving vehicle in reverse, ensure the path behind is clear of obstacles or bystanders. Remain seated.

**N: Neutral**

This position disengages the transmission to allow manual vehicle movement or towing.

**H: High gear**

This selects the high speed range of the transmission in the gear box. It is the normal riding position. It allows the vehicle to reach its maximum speed.

**L: Low gear**

This selects the low speed range of transmission in the gear box. It is the working position. It allows the vehicle to move slowly with the maximum traction and power.

Refer to ELECTRIC GEAR SHIFT BUTTON below for gear shifting.

The gear position is displayed with indicator lights. Refer to ELECTRIC GEAR SHIFT BUTTON below.

## 6) Transmission Lever Lock

Locate near the transmission lever.

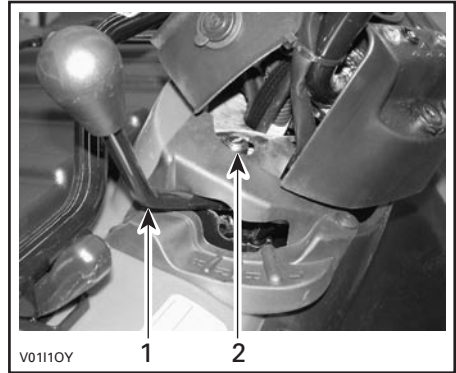

1. Transmission lever lock
2. Transmission lever

To lock the transmission lever, place the transmission lever on the PARK position and push down the bolt.

**NOTE:** The bolt can be locked without key, just press in.

To unlock, use the transmission lever lock key.

## 7) Outer Multi-Function Switch

This switch is located on the left side of handlebar, between handlebar grip and rear brake lever.

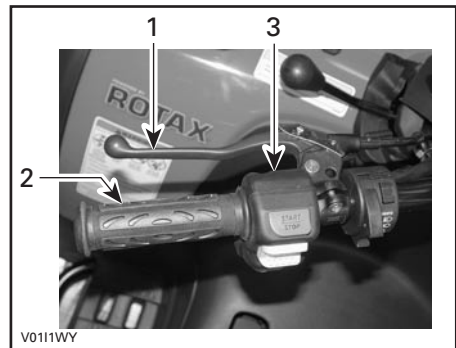

1. Rear brake lever
2. Handlebar grip
3. Outer multi-function switch

The controls located on this switch are:

### Electric Gear Shift Button

When pressing on the upper face, it shifts the transmission to the next higher gear. When pressing on the lower face, it shifts the transmission to the next lower gear.

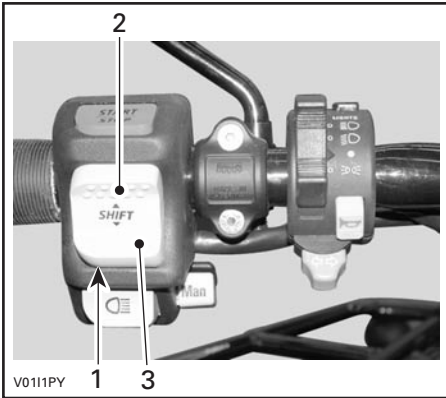

1. Gear shift button
2. Press here to upshift
3. Press here to downshift

The lower the gear, the slower the vehicle speed and the higher the gear, the higher the vehicle speed.

Vehicle must be running to allow gear change.

The button must be released then pressed again to perform another gear shift.

There are 5 gears in high and low gear positions.

This model features a manual/automatic selector located on the RH side of the multi-function switch. It is possible to change the mode at any time, even when vehicle is running.

The automatic mode activates a change of gear in accordance with the engine RPM and throttle opening. When automatic mode is selected, just press or release throttle lever.

On some occasion, it may be useful or necessary to manually change the gear selection. The electronic module will allow the rider to override the automatic mode by pressing the shift button to a lower gear or a higher gear. The automatic mode will be kept and the shifting sequence will resume after shift is performed.

**However, if the vehicle is used in severe conditions, it is highly recommended to use the manual mode.**

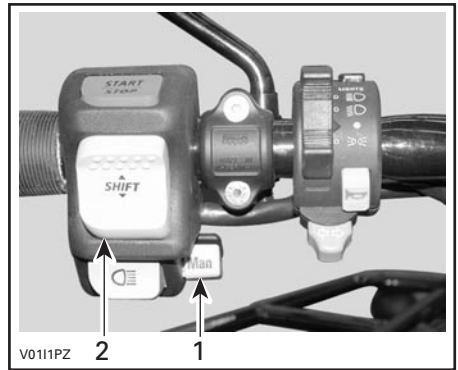

1. Manual/automatic selector
2. Gear shift button

### Start/Stop Switch

Dual function switch located on the top of the outer multi-function switch.

To start engine, press and hold the switch. Release immediately after engine is started.

To stop engine, fully release throttle lever then press the switch. It is not necessary to hold the switch.

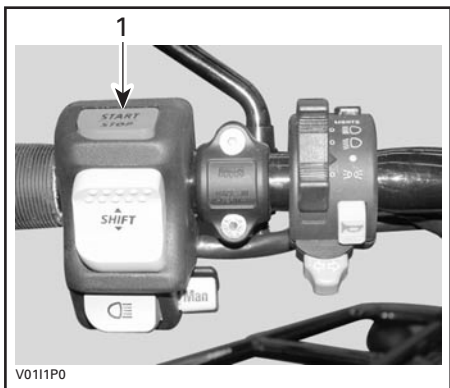

1. Start/stop switch

**NOTE:** While engine can be stopped by turning ignition key OFF, we recommend the engine be stopped by pressing the start/stop switch.

## 8) Inner Multi-Function Switch

This switch is located on the left side of handlebar, to the RH of rear brake lever.

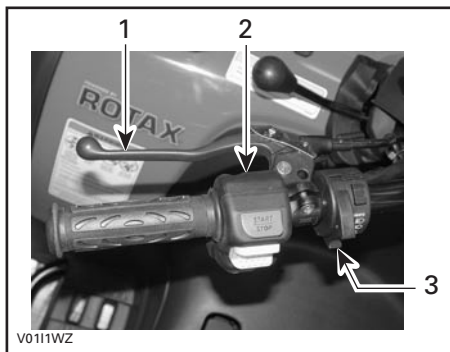

1. Rear brake lever
2. Inner multi-function switch
3. Outer multi-function switch

The controls located on this switch are:

## Headlight Switch

**NOTE:** The headlight dimmer switch located at the bottom of the outer multi-function switch is not functional. With this vehicle, use the headlight switch on the inner multi-function switch.

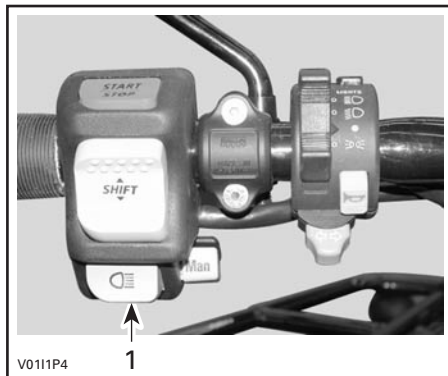

1. Dimmer switch (no functional on this vehicle)

The headlight switch controls the high and low beam position, the headlight OFF position and the parking lights position.

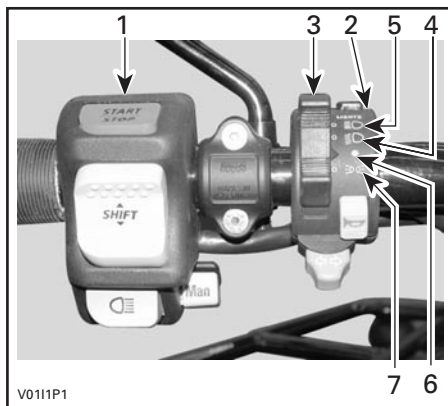

1. Outer multi-function switch
2. Inner multi-function switch
3. Headlight switch
4. Low beam position
5. High beam position
6. Headlight OFF position
7. Parking lights position

**NOTE:** The headlights do not turn on if the headlight switch is positioned to OFF position or if the ignition switch is positioned to ON "without light" position.

## Turn Signal Switch

This switch is located at the bottom of the inner multi-function switch.



ON POSITION "WITHOUT LIGHT"

## Horn Button

To set off the horn, press the horn button. Release immediately after horn is set off.

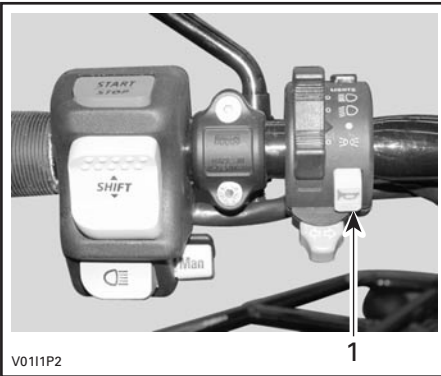

1. Horn button

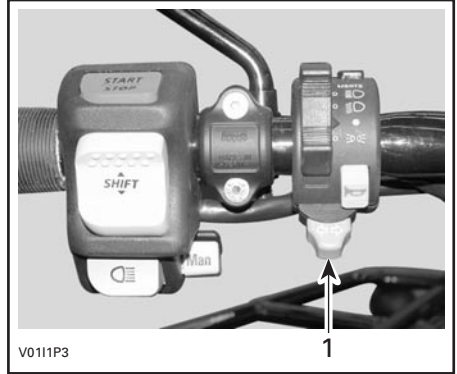

1. Turn signal switch

To turn to the right, push a the switch on the right side. When the turn is completed, reposition the switch in the middle.

For the left turn, perform the same procedure for the right turn but on the left side.

## 9) Hazard Warning Button

It is located on right side of cluster.

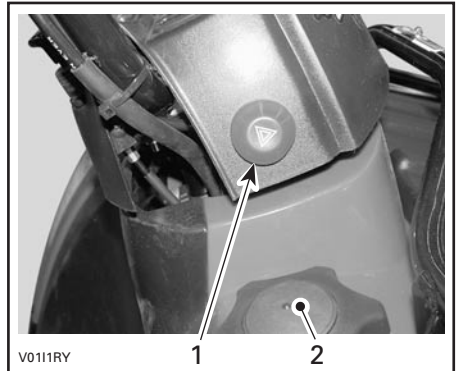

1. Hazard warning button  
2. Fuel tank cap

Device fitted to the vehicle that operates a simultaneous flashing of all the turn signals, used when the vehicle is stationary to indicate that the vehicle is temporarily obstructing traffic.

Press the hazard warning button once to activate the device. Press once again to deactivate.

The hazard warning button blinks also when the hazard warning lights blink.

## 10) Indicator Lights Cluster

**NOTE:** When first turning switch to ON (either position), all indicator lights, in the display panels, will turn on for a brief moment. This validates their operation. Thereafter, only the lights that are activated will remain on (Reverse, Neutral or Auto (on **AUTOSHIFT models only**), gear position and engine indicator lights).

If all lights flash, it indicates a particular malfunction of the transmission or the electrical system. See an authorized Bombardier ATV dealer as soon as possible.

### Left Display Panel

Located on left side of cluster. It lights up to indicate the gear position whenever the ignition switch is turned on when the transmission lever is NOT in PARK or in NEUTRAL position (either engine running or not).

If all lights flash **while shifting gear**, it indicates the shifting is not completed yet. Simply wait until the shifting completes or retry the shift with the gear shift button.

If all lights flash **continuously**, it indicates a damaged sensor (gearbox). Although the vehicle can still be operated in this condition, downshifting may increase engine "braking". Drive slowly. See an authorized Bombardier ATV dealer as soon as possible.

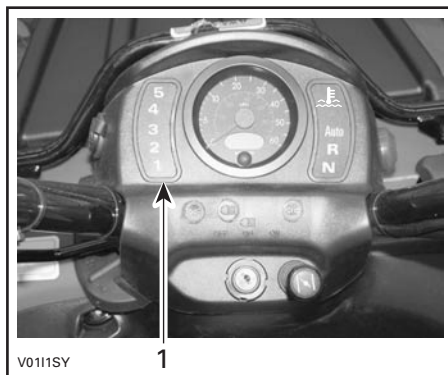

1. Gear position display

### Right Display Panel

Located on right side of cluster. They light up to monitor different functions.

If REVERSE and NEUTRAL lights flash **continuously**, it indicates a damaged sensor (sub-transmission). Although the vehicle can still be operated in this condition, downshifting may increase engine "braking". Drive slowly. See an authorized Bombardier ATV dealer as soon as possible.

IF AUTO light flash, it indicates a possible problem with the TPS sensor. The manual mode is immediately selected. See an authorized Bombardier ATV dealer as soon as possible.

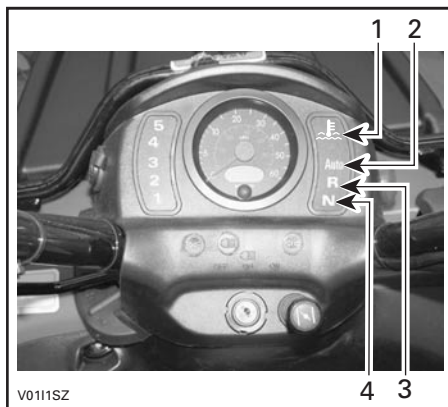

1. Engine
2. Auto (AUTOSHIFT position)
3. Reverse
4. Neutral

## Engine

Dual function light. When indicator light is ON, it indicates a low oil pressure condition of the engine. When flashing, it indicates the engine is overheating.

This light turns on when the ignition switch is turned on and remains on until engine is running.

**CAUTION:** If the light does not turn off right after engine starting, stop engine. See an authorized Bombardier ATV dealer. Do not use the vehicle until repaired.

If engine overheats, refer to **Engine Overheat** in SPECIAL PROCEDURES.

## Auto

When lit, it indicates the vehicle is operating in automatic mode.

## Reverse

When lit, it indicates the transmission is engaged in reverse.

## Neutral

When lit, it indicates the transmission is in neutral position.

## Other Indicator Lights

The others indicator lights are located between the ignition key and the speedometer.

**NOTE:** These indicator lights work only if the ignition key is positioned on the ON position with lights.

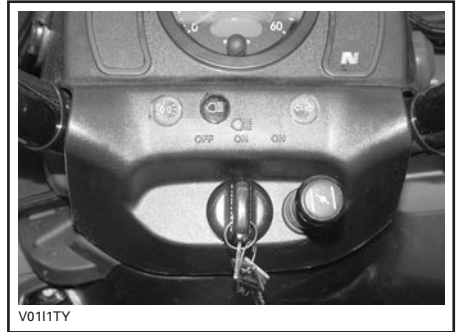

## Parking Lights

When the indicator light is ON, it indicates the Parking lights is turned on.

## High Intensity

When the indicator light is ON, it indicates the high intensity is selected on the headlights.

## Turn Signal

When the indicator light blink, it indicates the turn signal, left or right, is in operation.

## 11) Speedometer

Located in center of cluster. It indicates the speed of the vehicle in MPH and km/h. The speedometer is backlit when the ignition switch is turned on (either position).

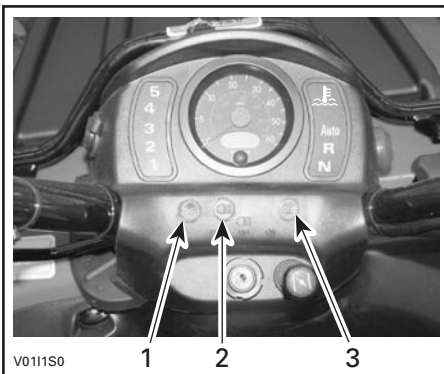

1. Parking lights
2. High intensity
3. Turn signal



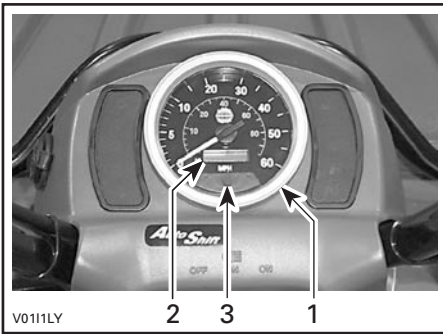

1. Speedometer
2. Odometer/trip meter/hourmeter
3. Display selection button

### **Odometer/Trip Meter/Hourmeter**

Combined LCD (Liquid Crystal Display) display. Odometer records the total distance traveled in miles or in km/h (00000). The trip meter records the distance traveled in miles or in km/h (000.0) until it is reset. The last right digit indicates the tenth of a mile or in km/h (on trip meter mode only). It can be used to approximately monitor the fuel tank range or distance between two locations for instance. The hourmeter records total hours when the ignition switch is turned ON (H0000.0).

### **Display Selection Button**

To change the display momentarily press the button on the speedometer. The display will indicate odometer/trip meter/hourmeter, one after the other.

To reset the trip meter, push and HOLD button until all numbers read zero. The trip meter can be reseted any time, even if the odometer or the hourmeter is selected.



The odometer can indicate in miles or in kilometers. See below for the procedure.

### **Change from One Unit to the Other**

The speedometer is factory pre-set in miles but it is possible to change it to kilometer reading.

**NOTE:** The unit modification is applied to the speedometer, odometer and trip meter.

Turn ignition switch OFF.

Press and hold the display selection button.

Turn ignition switch ON. The display should be blinks during 10 seconds approximately. When the display stay on, release the button. The units should be change from miles to kilometers

A dash appears on the left side of the LCD display to indicate which unit is used.

## 12) Rear Passenger Grab Handles

The grab handles are located on each side of passenger seat.

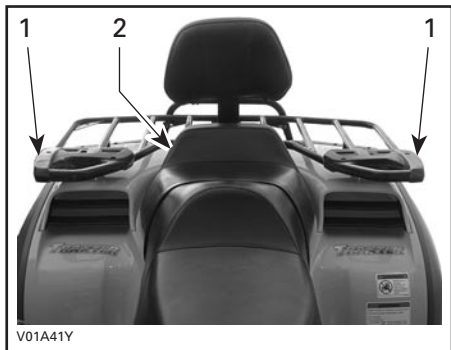

### TYPICAL

1. Grab handles
2. Passenger seat

The grab handles must be used by the passenger to hold on to it firmly during vehicle operation.

## WARNING

Never hold on to the operator. Always take the grab handles firmly.



### TYPICAL

## 13) Backrest

Part used to support the passenger's back during the ride.

## WARNING

Never ride with a passenger if the backrest is removed. Check the solidity of the backrest before each rides.

## 14) Ignition Switch

Located at bottom of cluster.

Key-operated, 3-position switch: OFF, ON with lights and ON without lights.

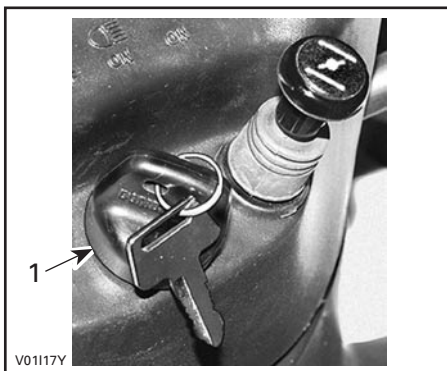

1. Ignition switch

Insert key in switch and turn to the desired position. To remove key, turn key to OFF then pull it out.

The ON with lights position, turns on all lights with either the engine running or not. The headlights automatically dim to low intensity. Remember that having the lights on without the engine running discharges the battery. Always turn ignition to OFF after engine has been stopped.

**NOTE:** While engine can be stopped by turning ignition key OFF, we recommend the engine be stopped by pressing the start/stop switch.

## Auto Shut-Down

If for some reason, the engine is not started within 3 minutes approximately, the MPEM (Multi-Purpose Electronic Module) will shut down to cut all electrical system functions. Simply turn the key to OFF then to ON to regain normal use.

## 15) Choke Knob Lever

Located at bottom of cluster. This device features a variable lever to ease cold start.

Position OFF is for normal use with a warm engine (pushed in).



*CHOKE KNOB LEVER IN THE OFF POSITION*

The full choke position is used for lower temperature (fully extended).



*CHOKE LEVER IN THE FULL CHOKE POSITION*

The other positions between OFF and FULL position, will be use depending on the temperature.

## 16) Fuel Tank Cap

Unscrew counterclockwise and remove cap to allow fuel tank filling then fully tighten clockwise.

### **⚠ WARNING**

Always stop engine before refueling. Open cap slowly. If a differential pressure condition is noticed (whistling sound heard when loosening fuel tank cap) have vehicle inspected and/or repaired before further operation. Fuel is flammable and explosive. Never use an open flame to check fuel level. Never smoke or allow flame or spark in vicinity. Always work in a well-ventilated area. Never top up the fuel tank before placing the vehicle in a warm area. As temperature increases, fuel expands and may overflow. Always wipe off any fuel spillage from the vehicle.

## 17) Fuel Gauge

Located under cluster, the gauge shows an approximate amount of the fuel in tank.

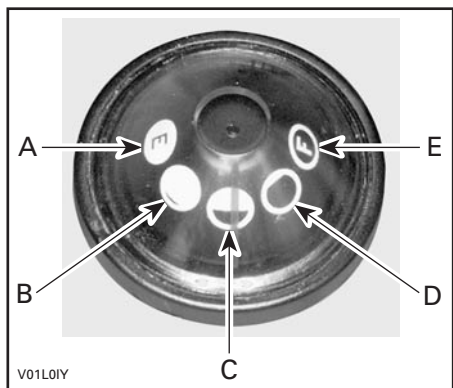

- A. Empty
- B. 1/4
- C. 1/2
- D. 3/4
- E. Full

## 18) Fuel Valve

Located on left side panel under front part of seat. 3-position rotary valve: OFF, ON, RES. Rotate the knob to align its pointer with ON, OFF or RES.

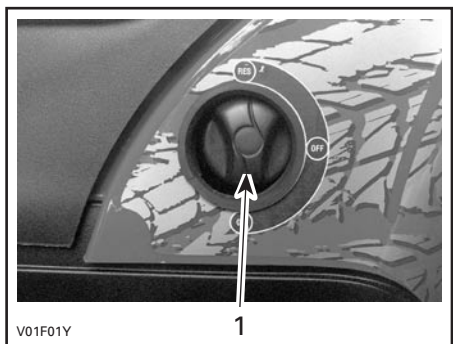

1. Align this pointer toward the desired position

### OFF

Stops fuel supply to carburetor.

**CAUTION:** Turn valve to OFF position when vehicle is not being operated or when transporting.

### ON

Allows fuel to flow to carburetor. This is the normal position for operation of the vehicle.

## RES (reserve)

When fuel is exhausted in the fuel tank when in the ON position, an emergency supply of fuel is available by turning the knob to RES. The reserve contains approximately 30% of the fuel tank capacity. Use only this position when the ON supply is empty.

When down to the reserve, refuel as soon as possible. Ensure to turn the valve back to the ON position after refuelling.

**CAUTION:** Improper opening of fuel valve will restrict the flow of fuel. Make sure valve is fully opened while running.

## 19) Rear Brake Pedal

Located on the right footrest. When pressed down, the rear brake is applied. When released, it should return to its original position. Braking effect is proportional to the force applied on the pedal and to the type and condition of the terrain.

**NOTE:** The brake will have also an effect on front wheels through the drive train.

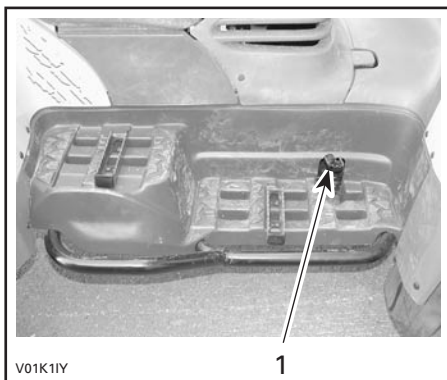

1. Rear brake pedal

## 20) Rewind Starter Handle

The rewind starter handle is provided as an emergency starting device.

Follow the usual starting procedure; but use the rewind starter instead of the electric starter.

Located on left side panel under front part of seat. Auto-rewind type. To engage mechanism, pull handle slowly until a resistance is felt then continue to slowly pull the handle until the compression stroke **peak** (strong rotating resistance) is overpassed then, pull vigorously. Slowly release handle.

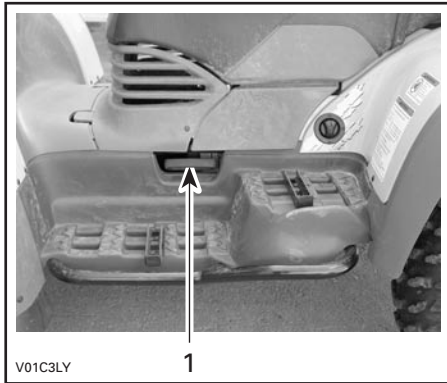

1. Rewind starter handle

## 21) Footpeg

Located on footrest. Use this area to maintain your feet stable.

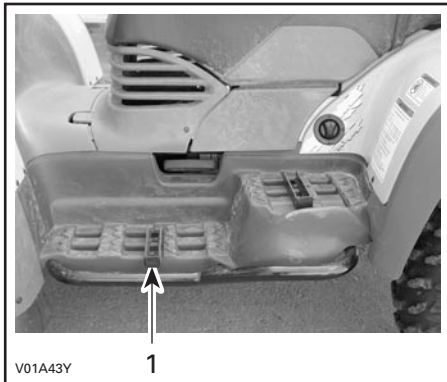

1. Footpeg

## 22) Foot Board

Locate on each footrests. The foot boards are used by the passenger to maintain his feet stable.

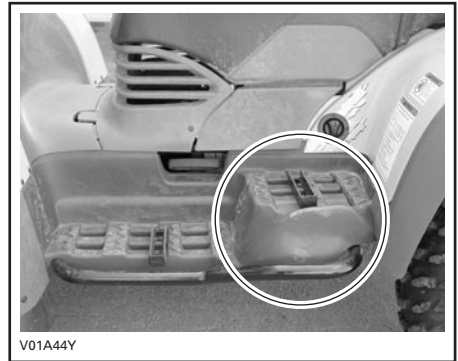

## 23) Storage Compartment

Located in front of vehicle. Convenient location to carry personal articles such as an a helmet, spare spark plugs, first aid kit, etc. Unlatch cover, gently lift then remove cover.

The compartment is equipped with a drain plug under the tool box. Remove plug to allow draining when necessary. Reinstall plug when finished.

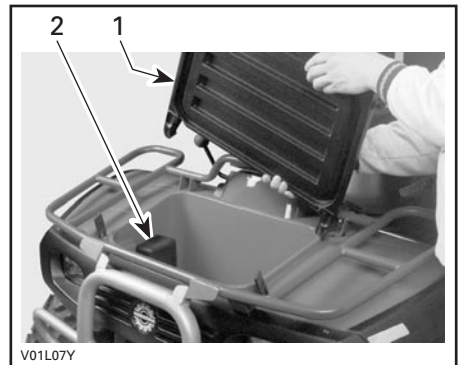

TYPICAL

1. Removing cover
2. Tool box

It also contains this *Operator's Guide* that should be kept in a waterproof bag and remain with the vehicle at all times.

## WARNING

When engine is running, always engage the PARK position on the transmission lever before opening cover. Never leave any heavy or loose breakable objects in the storage basket. Always latch cover before riding. If storage cover is removed to provide greater carrying area, ensure that cargo is secured and will not "fly out" when riding at speed on rough terrain. Slow down.

## 24) Tool Box

Located in storage compartment. The tool box contains tools for basic maintenance, this *Operator's Guide*, the *Safety Training guide* and the *ATV Winch Manual (XT models only)*.

The tools included in the tool box are:

- pliers (1)
- screwdriver (1)
- open wrench 10/13 mm (1)
- open wrench 15/17 mm (1)
- socket wrench 10/13 mm (1)
- socket wrench 16/18 mm (1)
- tire pressure gauge (1)
- Allen key 3 mm (1)
- shock absorber key (1)
- fuse 30 A (1)
- fuse 20 A (1)
- fuse 15 A (1)
- emergency shifter key (1).

## 25) Seat Latch

Located underneath rear end of seat. It allows the removal of seat to give access to engine compartment.

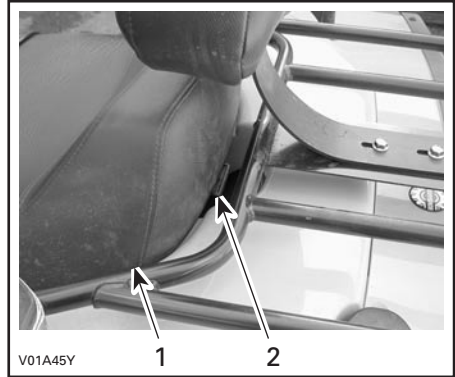

1. Seat
2. Seat latch

## Seat Removal

Pull latch upward while gently lifting rear of seat. Continue lifting movement until you can release the front retaining devices then completely remove seat.

## Seat Installation

Place seat to allow the insertion of the U-shaped bracket over the rollers. Gently slide the brackets over rollers then lower seat. When seat rests in its position, firmly push seat down to latch.

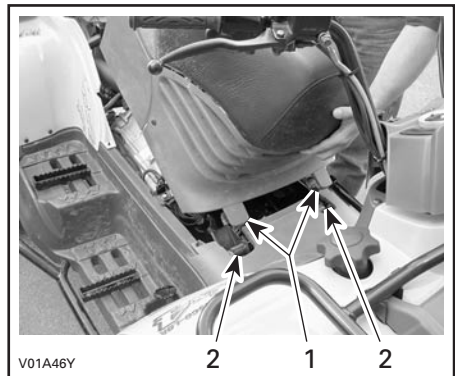

1. U-shaped bracket
2. Rollers

## **WARNING**

Periodically verify the seat lock pin and tighten if needed. Make sure seat is securely latched before riding.

## **26) Front/Rear Cargo Racks**

Located on top of chassis at front and rear. Convenient racks to carry gear.

## **WARNING**

Ensure to properly secure material to rack. Do not overload. Ensure load does not interfere with visibility and/or steering. Do not carry passenger(s).

Refer to SPECIFICATIONS for carrying loads and cargo weight distribution recommendations.

## **27) Air Duct**

Located on rear fenders. They force the flow of air to cool radiator and supply air inside air box.

**CAUTION:** Do not place anything over air intake ducts.

## **28) Trailer Hitch**

Located on rear axle. Convenient hitch to install a ball to tow a trailer or other equipment. Install the proper ball size as per trailer manufacturer recommendations. Refer to SPECIFICATIONS for carrying loads and towing recommendations.

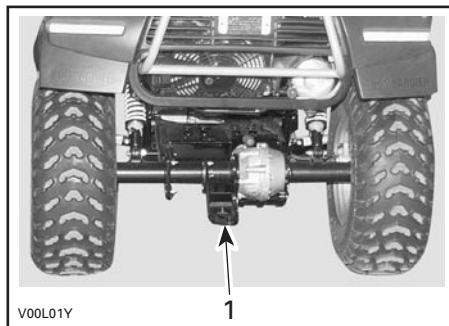

*TYPICAL*

1. Trailer hitch

## **WARNING**

Ensure to install the proper ball size that matches the equipment you will tow.

Follow manufacturer instructions for proper attachment.

## **29) Radiator Cap**

Located at rear of rear panel. It provides access to the radiator filling neck.

Pull the protector cap to give access to the radiator cap. When finished, properly reinstall radiator cap then protector cap.

## **WARNING**

To prevent burning yourself do not remove the radiator cap if the engine is hot.

Do not exceed the rating capacity. See SPECIFICATIONS.

An auxiliary supply is available to connect additional accessories. Two wires are hidden in the wiring harness at the rear of vehicle. See an authorized Bombardier ATV dealer for more details.

### 31) Fuses

The electrical system is protected with fuses. Refer to MAINTENANCE for details.

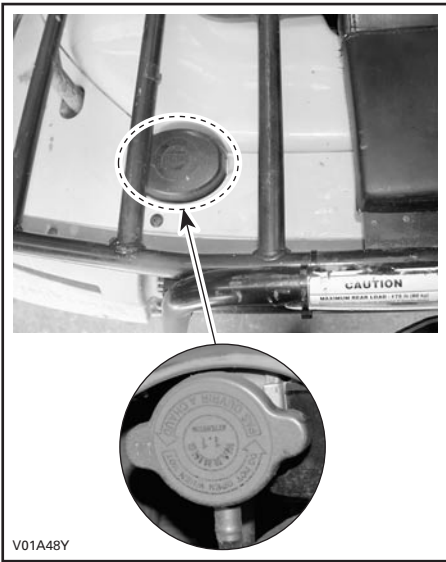

V01A48Y

### 30) 12-Volt Power Outlet

It is located on left side of cluster.

Convenient for handheld spotlight or other portable equipment.

Remove cap to use. Always reinstall protective cap after use to protect against weather.

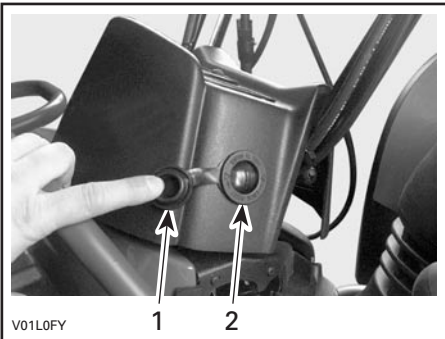

V01L0FY

1. Protective cap
2. Power outlet



---

# LIQUIDS

While reading this *Operator's Guide*, remember that:

## WARNING

Indicates a potential hazard that, if not avoided, could result in serious injury or death.

This section specifies the recommended liquids and procedures to check their levels. Refer to MAINTENANCE for procedures to replace the liquids.

## Fuel

### Recommended Fuel

Use regular unleaded gasoline or gasohol containing less than 10% of ethanol or methanol, available from most service stations. The gasoline used must have an octane number of 87 ((R + M)/2) or higher.

**NOTE:** In most service station, pump octane number corresponds to (R + M)/2 octane number. Usually a sticker can be found on the pump.

**CAUTION:** Never experiment with other fuels. The use of unrecommended fuel can result in vehicle performance deterioration and damage to critical parts in the fuel system and engine components.

**CAUTION:** Never mix oil with fuel. This vehicle has a 4-stroke engine. Oil must be added to engine base only.

## Fuel Level

### WARNING

Never top up the fuel tank before placing the vehicle in a warm area. As temperature increases, fuel expands and may overflow. Fuel is flammable and explosive under certain conditions. Always wipe off any fuel or oil spillage from the vehicle.

## Engine/Transmission Oil

### Recommended Oil

Use 4-stroke mineral-based engine oil that meets or exceeds the requirements for API service classification SG, SH or SJ. Always check the API service label on the oil container to be sure it includes the letters SG, SH or SJ. Only use high-quality high-detergent oil.

**NOTE:** The same oil lubricates both engine and transmission. For improve overall performance and wear protection use **Bombardier synthetic oil (P/N 293 600 039)**. This is a special synthetic oil formulated for clutch type gear box.

**CAUTION:** Use of synthetic or synthetic blend oil, other than **Bombardier synthetic oil 5W40 (P/N 293 600 039)**, may cause clutch slippage.

## Oil Viscosity

SAE 10W40 is recommended for summer time.

SAE 5W30 is recommended for winter time.

Other viscosity should be used if the average temperature is outside the range of the recommended oil. See chart below.

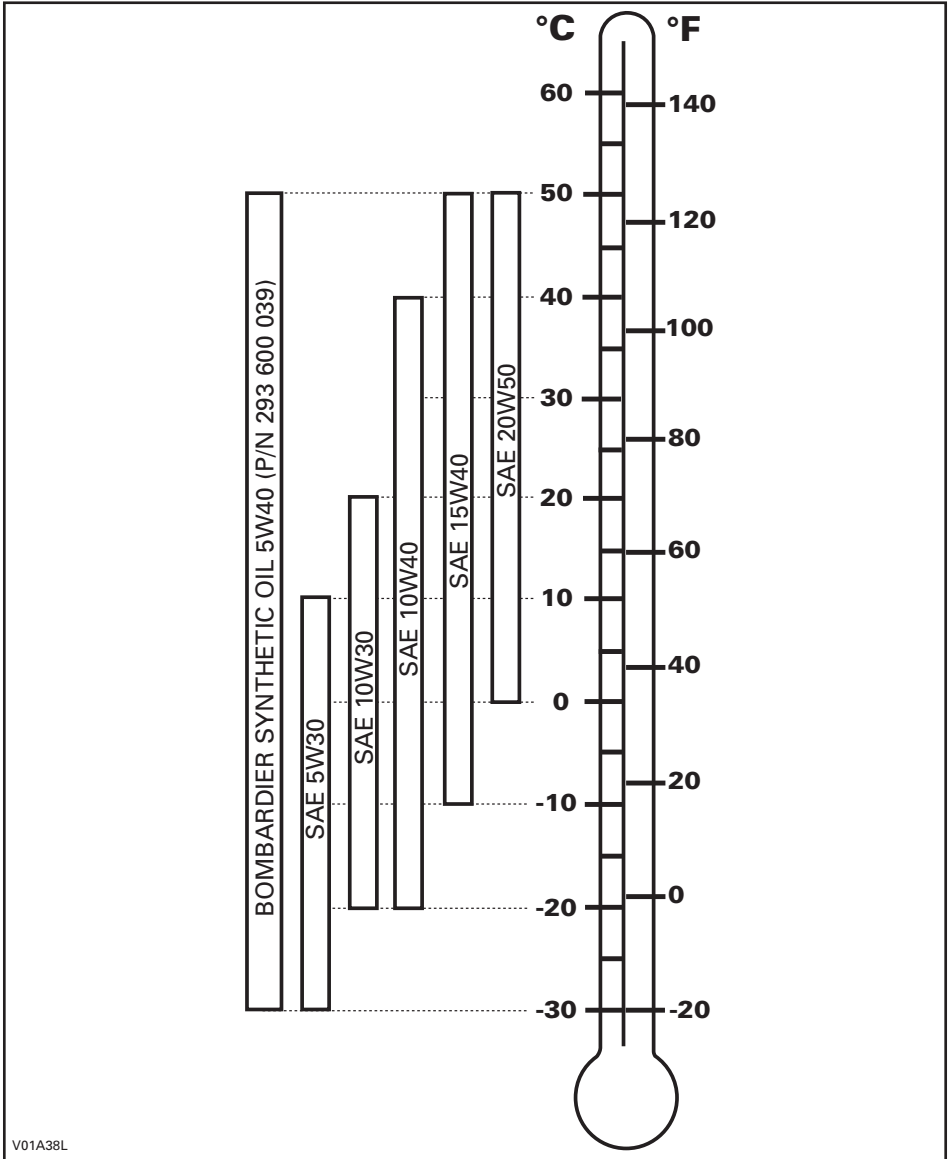

V01A38L

## Oil Level

**CAUTION:** Check level frequently and refill if necessary. Do not overfill. Operating the engine/transmission with an improper level may severely damage engine/transmission. Wipe off any spillage.

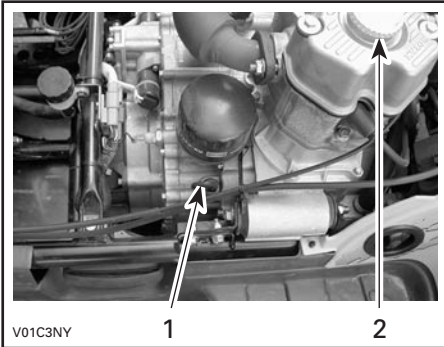

### LH SIDE OF ENGINE

1. Dipstick
2. Filler cap

With vehicle on a level surface and engine cold, not running, check the oil level as follows:

1. Pull dipstick out and wipe clean.

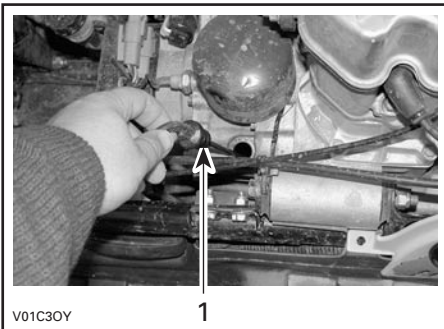

1. Pull out dipstick
2. Reinstall dipstick until it bottoms.
3. Remove and check oil level. It should be near or equal with the upper mark.

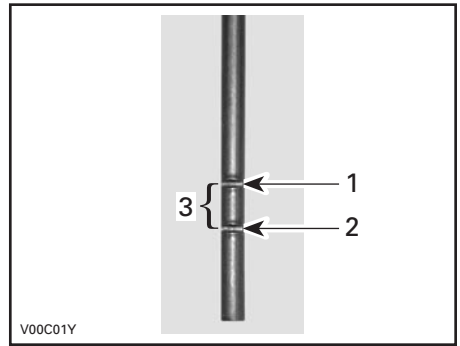

1. Full
2. Add
3. Operating range
4. Add oil up to upper mark if required.
5. To add oil, unscrew filler cap. Use a funnel to avoid spillage. Do not overfill.
6. Properly reseal dipstick, reinstall and tighten filler cap then reinstall seat.

## Engine Coolant

### Recommended Coolant

Always use ethylene-glycol antifreeze containing corrosion inhibitors specifically for internal combustion aluminum engines.

Cooling system must be filled with water and antifreeze solution (50% water, 50% antifreeze).

### Coolant Level

#### **WARNING**

Check coolant level with engine cold. Never add coolant in cooling system when engine is hot.

Remove seat.

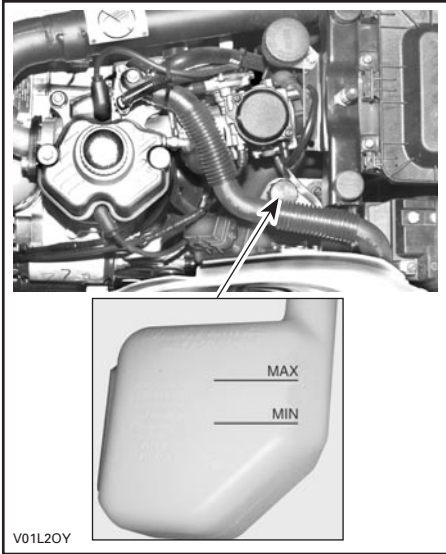

With vehicle on a level surface, liquid should be between MIN. and MAX. level marks of coolant reservoir.

**NOTE:** When checking level at temperature lower than 20°C (68°F), it may be slightly lower than MIN. mark.

Add coolant up to MAX. mark if required. Use a funnel to avoid spillage. **Do not overfill.**

Properly reinstall and tighten filler cap and reinstall seat.

If the coolant is added in the coolant reservoir, check the level in the radiator too. Add coolant if necessary.

### **⚠ WARNING**

To prevent burning yourself do not remove the radiator cap if the engine is hot.

**NOTE:** A cooling system that frequently requires coolant is the indication of leaks or engine problems. See an authorized Bombardier ATV dealer.

## **Coolant Replacement**

Refer to MAINTENANCE section.

## **Brake Fluid**

### **Recommended Fluid**

Always use brake fluid meeting the specification DOT 4 only.

**CAUTION:** To avoid serious damage to the braking system, do not use fluids other than the recommended one, nor mix different fluids for topping up.

### **Fluid Level**

With vehicle on a level surface, check brake fluid in reservoir for proper level. It should be above MIN. mark.

Add fluid as required. **Do not overfill.** Clean filler cap before removing.

**CAUTION:** Use only DOT 4 brake fluid from a sealed container. Do not use brake fluid taken from old or already opened containers.

**NOTE:** A low level may indicate leaks or worn brake pads. See an authorized Bombardier ATV dealer.

### **Front Brake Fluid Reservoir**

Turn steering in the straight-ahead position to ensure reservoir is level.

Check the brake fluid level, the reservoir is full when the fluid reaches the top of window.

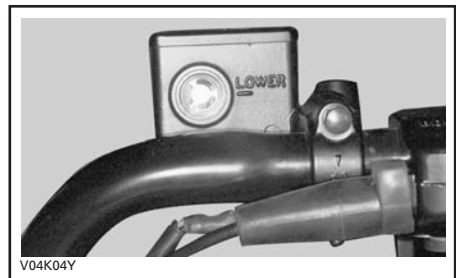

Visually inspect lever boot condition. Check for cracks, tears etc. Replace if damaged.

## Rear Brake Fluid Reservoir

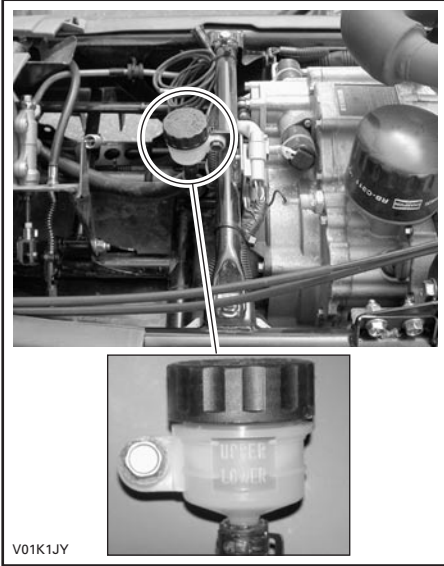

## Battery Electrolyte Recommended Liquid

It is recommended to use distilled water.

### Electrolyte Level

Place the vehicle on a level surface.

Check electrolyte level by the rear left inner fender. Use a flashlight if necessary. Do not use an open flame.

The electrolyte should be between low-er and upper marks. If level is low, re-move battery from vehicle to add dis-tilled water.

## Battery

### Removal

Disconnect BLACK (-) cable first then RED (+) cable.

### WARNING

Always respect this order for dis-assembly; disconnect BLACK (-) cable first. Electrolyte or fuel vap-ors can be present in engine compartment and a spark may ig-nite them and possibly cause per-sonal injuries.

Remove the holding straps.

Pull out vent tube from frame.

Remove battery from vehicle being careful not to tilt it so that electrolyte flows out of vent tube.

### WARNING

Battery electrolyte is a caustic sub-stance that burns or destroys or-ganic tissues by chemical action. Avoid contact with eyes, skin and clothing. Wear protective eye-glasses and a suitable pair of non-absorbent gloves when removing the battery by hand. Should any electrolyte spillage occur, imme-diately wash off with a solution of baking soda and water.

## Refilling

Place battery on a level surface.

Unscrew caps and add distilled water up to upper mark as required. Do not overfill.

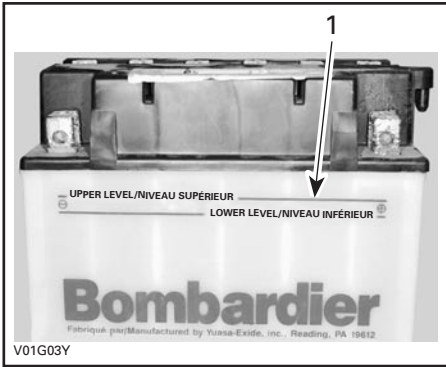

1. Upper mark

Properly retighten caps.

## Installation

Reinstall battery in vehicle. Fasten battery and make sure to reinstall the vent tube.

### **WARNING**

Connect RED (+) cable first then BLACK (-) cable. Always connect RED (+) cable first.

**NOTE:** Place the RED (+) cable between holding straps and battery.

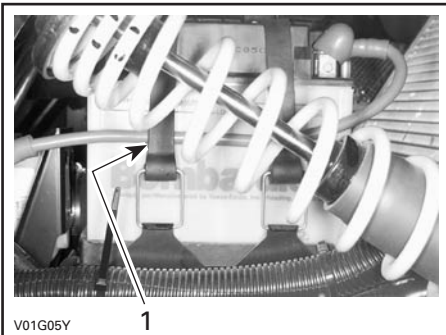

1. Cable between battery and strap

---

# BREAK-IN PERIOD

## Engine

A break-in period of 10 operating hours is required before running the vehicle at sustained full throttle.

**CAUTION: Never mix oil with fuel. This vehicle has a 4-stroke engine. Oil must be added to engine base only.**

During this period, maximum throttle should not exceed  $\frac{3}{4}$ . **However, brief full acceleration and speed variations contribute to a good break-in.** Continued wide open throttle accelerations, prolonged cruising speeds and engine overheating are detrimental during the break-in period.

## 10-Hour Inspection

As with any precision piece of mechanical equipment, we suggest that after the first 10 hours or 30 days after the purchase, whichever comes first, your vehicle be inspected by an authorized Bombardier ATV dealer. This inspection will give you the opportunity to discuss the unanswered questions you may have encountered during the first hours of operation.

---

**The 10-hour inspection is at the expense of the vehicle owner.**

---

While reading this *Operator's Guide*, remember that:

### **WARNING**

Indicates a potential hazard that, if not avoided, could result in serious injury or death.

---

# PRE-OPERATION CHECK

## **WARNING**

The pre-operation check is very important prior to operating the vehicle. Always check the proper operation of critical controls, safety features and mechanical components before starting. If not done as specified here, severe injury or death might occur.

- Apply parking brake and check if it operates properly.
- Check tire pressure and condition.
- Check wheels and bearings for wear and damage.
- Check location of controls and ensure they work properly.
- Verify steering operates freely.
- Activate throttle control lever several times to ensure it operates freely. It must return to idle position when released.
- Activate the brake levers and foot pedal to make sure the brakes fully apply. Levers and pedal must fully return when released.
- Ensure transmission lever is working then reset in PARK position.
- Check fuel, oil and coolant levels.
- Check for oil leaks on the engine/transmission and drive train components.
- Ensure fuel valve is in fully open position (ON).
- Clean headlights and taillight.
- Ensure front storage cover compartment is properly latched.
- Ensure seat is properly latched.
- If you transport cargo, respect load capacity. Ensure cargo is properly secured to the racks.
- If you are pulling a trailer or other equipment, ensure it respects the tongue capacity and towing capacity. Ensure trailer is properly secured to hitch.
- Look and feel for loose parts while engine is off. Check fasteners.
- Ensure the path of travel is free of persons and obstacles.
- Check operation of ignition and start/stop switches, headlights, dimmer switch, taillight and indicator lights.
- Start engine and drive forward slowly a few feet and apply all brakes individually to test them.
- Check backrest condition.
- Check passenger grab handles condition.
- Educate the passenger concerning the basic rules for a safety ride.

**Correct any problem you may have found. See an authorized Bombardier ATV dealer as necessary.**



# OPERATING INSTRUCTIONS

## General

Engine can be started in any gear (from 1 to 5).

Transmission lever must be on PARK or NEUTRAL to allow engine starting.

For your convenience, an override mode allows to start the engine with the transmission lever in any position. Press and hold the front or rear brake lever or the brake pedal while pressing the start button.

## Initial Cold Starting

Insert key in ignition switch and turn to ON.

In cold weather, colder than 0°C (32°F), fully pull up the choke lever.



1. Full choke position

**NOTE:** When the temperature is below -15°C (5°F), the primer kit (P/N 703 500 045) installation is recommended. See an authorized Bombardier ATV dealer.

Press start/stop button and hold until engine starts.

**CAUTION:** Do not hold start/stop switch or start button more than 30 seconds. A rest period should be observed between the cranking cycles to let starter cool down. Pay attention not to discharge battery.

**NOTE:** Throttle assist may be use to help engine starting faster. Press the throttle lever slightly. If to much throttle is used the choke system will not be activated.

Release start/stop switch or start button immediately when engine has started.

After a few seconds, push in the choke lever from full choke position to an intermediate position until a best engine RPM is achieved.

**NOTE:** Overusing choke may flood engine and make it hard to start. Refer to SPECIAL PROCEDURES if it occurs.

When the engine is warm, push the choke lever to OFF and release brakes.

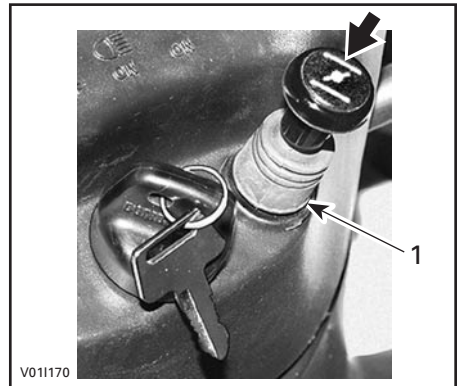

1. OFF position

## Warm Engine Starting

Start the engine as explained above but without any choke. If the engine will not start after two 5-second attempts with the electric starter, pull the choke lever and place it half way position. Start the engine without activating the throttle lever. After few times, push the choke lever to OFF.

## Emergency Manual Starting

### **WARNING**

Always place transmission lever on PARK or NEUTRAL before starting engine manually.

Manual start is provided in the event electric start does not work.

If the engine indicator light is turned off, it indicates the electrical system is in the auto shut-down mode. Turn the ignition key OFF then ON to reactivate it.

Follow the same procedure as starting procedures above except use the re-wind starter to start instead.

Grasp manual starter handle firmly and, slowly, crank engine until a resistance appears.

Pass this resistance and release the handle.

Take again the handle firmly and crank engine.

Repeat this procedure completely if necessary.

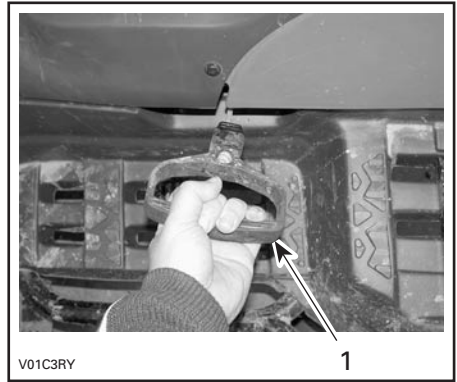

1. Grasp manual starter handle firmly and crank engine

## Stopping the Engine

### **WARNING**

Avoid parking on an incline surface.

Release throttle and completely stop the vehicle.

Apply the parking brake by using brake lever lock on rear brake lever.

Shift to 1<sup>st</sup> gear.

Set transmission lever in PARK position.

Press the start/stop switch or push the engine stop switch in OFF position.

Turn key in ignition switch to OFF.

Remove key from ignition switch.

## Shifting the Transmission

Let engine idle to warm up.

Apply brakes and select the desired gear range H/L.

**NOTE:** The brake must be applied when the transmission lever is engaged in the park position. Shift to 1<sup>st</sup> gear.

Release brakes.

**CAUTION:** Make sure parking brake is fully disengaged before operating the vehicle.

Gradually press the throttle lever to increase engine speed and thus engaging the centrifugal clutch.

When vehicle speed increases, slightly release throttle lever while pressing the electric gear shift button to upshift one gear then release button and press throttle lever again to continue the acceleration. Repeat until the last gear if desired or until vehicle speed you want is attained.

**NOTE:** While any throttle position can be used during shifting, it is recommended to slightly release the throttle position during upshifting.

Reverse the sequence to downshift.

### **Manual/Automatic Selector**

When selector is in automatic mode, the transmission upshift automatically when the vehicle speed increases. Inversely, when vehicle speed decreases, the transmission downshifts automatically.

### **Using the Reverse**

**CAUTION:** When changing from forward to reverse, or vice-versa, always completely stop the vehicle and apply the brake prior to moving the transmission lever.

The same procedures as SHIFTING THE TRANSMISSION above apply except for the following.

Set the transmission lever in REVERSE position.

---

# SPECIAL PROCEDURES

## Flooded Engine

When the engine does not start after several attempts, the engine may be fuel flooded. Proceed as follows.

Turn ignition switch to ON and ensure choke is not applied.

Ensure the transmission lever is on PARK.

Fully press throttle lever and hold while starting the engine.

As soon as the engine starts, release throttle lever. Do not race engine.

### If it does not work:

Disconnect spark plug cables.

Clean the spark plug areas then remove spark plugs (tools are supplied in tool box).

Crank engine several times. Add a small quantity of engine oil in cylinder (equivalent to a cap of oil quart). Install new spark plugs if possible or clean and dry spark plugs.

Start engine as explained above. If engine continues to flood, see an authorized Bombardier ATV dealer.

## Engine Overheat

If engine overheats and indicator light turns on, try the following:

Ensure air ducts are not obstructed.

Check and clean radiator fins. See MAINTENANCE section.

### WARNING

The radiator can be very hot, wear gloves before touching radiator.

Reduce vehicle speed but try to keep vehicle moving to supply air to radiator. If engine is still overheating after approximately one minute, stop vehicle and set transmission to PARK. Stop engine.

Place the ignition switch to ON position (**Do not restart engine yet**). The radiator fan will allow to cool the radiator.

Let engine cool down. Check coolant level and refill if possible.

### WARNING

Never refill cooling system when engine is hot.

See an authorized Bombardier ATV dealer as soon as possible.

## Flipped Over

When vehicle is flipped over or stays tilted on the side, replace the vehicle in its normal operating position (on all four wheels) and wait 3 to 5 minutes before starting engine. Before starting engine, check engine oil level and refill if necessary. If the oil pressure light stays ON after starting engine, stop engine and see an authorized Bombardier ATV dealer as soon as possible.

## Vehicle Immersion

Should the vehicle become immersed, it will be necessary to take it to an authorized Bombardier ATV dealer as soon as possible. **DO NOT START THE ENGINE!** Immersion of the vehicle can cause serious damage if the correct restart procedure is not followed.

## Post-Operation Care

When vehicle is used in salt-water environment (beach area, launching/loading boats etc.), rinsing the vehicle with fresh water is necessary to preserve vehicle and its components. Metallic parts lubrication is highly recommended. Use BOMBARDIER LUBE (P/N 293 600 016). This must be performed at the end of each operating day.

When vehicle is operated in muddy conditions, rinsing the vehicle is recommended to preserve vehicle and its components and to keep lights clean.

## Emergency Shifter

If the shifting system is not operational, you may use the emergency shifter. It allows to change the transmission gear when the vehicle is not in motion. You set the desired gear once then go back home while the transmission remains in this gear. No gear change can take place since the shifting system is not operational. The shifter shaft end is located on rear side of engine.

Place transmission on PARK position.

Remove seat.

- Use the special key in the tool box to rotate the emergency shifter. Open the tab of the tool approximately at a right angle (90°). Insert the screwdriver included in the tool box at the end of the special tool so that it can be used as a handgrip.

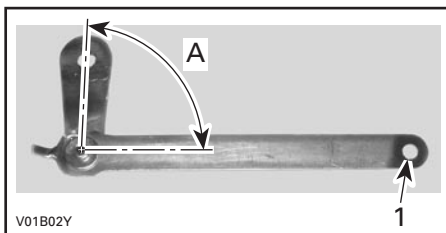

1. Insert the screwdriver here as a handgrip  
A. Open tab at a right angle (90°)

## WARNING

The exhaust pipe can be very hot. Wear gloves and/or allow exhaust pipe to cool.

Insert the tool to the end of the shifter shaft.

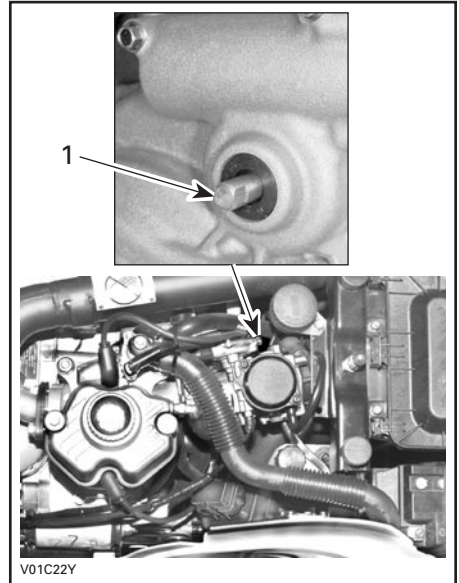

1. Emergency shifter shaft. Insert special tool here

Pull special tool upward to downshift and push downward to upshift. Place the gear in the desired position.

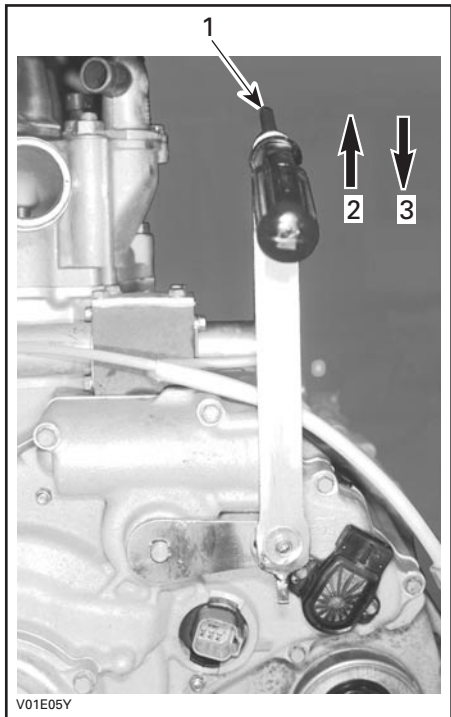

1. Use screwdriver as a handgrip
2. Pull to downshift
3. Push to upshift

**NOTE:** The 2<sup>nd</sup> or 3<sup>rd</sup> gear is recommended.

Remove the special tool. Close the tab of the tool. Replace tool and screwdriver in tool box.

Replace seat.

## Storage and Preseason Preparation

### **WARNING**

Have an authorized Bombardier ATV dealer inspect fuel system integrity as specified in MAINTENANCE CHART.

When a vehicle is not in use for more than one month, proper storage is a necessity.

See an authorized Bombardier ATV dealer for proper procedures.

When using your vehicle after storage, a preparation is required. See an authorized Bombardier ATV dealer for proper procedures.

# CARGO AND TRANSPORTATION

While reading this *Operator's Guide*, remember that:

## WARNING

Indicates a potential hazard that, if not avoided, could result in serious injury or death.

## Cargo

## WARNING

The vehicle handling, stability and braking distance are affected when loading racks and using the vehicle. Correct loading and weight distribution are therefore important. Never overload, tow or carry cargo improperly. Always ensure the cargo is safely secured and properly distributed on the rack(s) before operating the vehicle. Safely reduce speed when carrying cargo or pulling a trailer. Allow greater distance for breaking. Always secure cargo as low as possible on the rack(s) to reduce the effect of a higher center of gravity. Failure to follow the recommendations here could cause changes in vehicle handling which could lead to an accident resulting in severe injuries including the possibility of death.

When cargoing vehicle, respect these maximum loads.

**TOTAL LOAD ALLOWED:**

**290 kg (690 lb)**

(includes driver and passenger, all other loads and added accessories)

### FRONT

**40 kg (90 lb)**

Includes FRONT rack and storage compartment



### REAR

**80 kg (175 lb)**

Includes REAR rack and tongue load

V01A4DL

TYPICAL

## Transportation

When transporting a vehicle, secure vehicle to trailer or in pickup box with suitable tie-downs. Using ordinary ropes is not recommended.

### **WARNING**

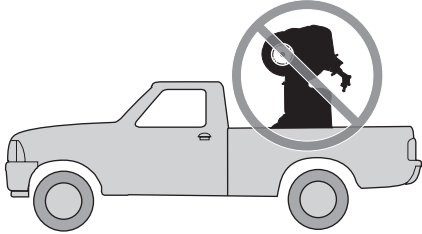

V00A174

Never tip this vehicle on end for transporting. We recommend that you carry the vehicle in its normal operating position (on all four wheels).

Place the fuel valve to OFF position.  
Select the PARK position and set the parking brake.

Secure the vehicle to front by the front bumper and rear by the frame.

**CAUTION:** Attaching vehicle at other locations may damage the vehicle.

Unload rack(s) before transporting the vehicle.

## Front Location



V00A15Y

TYPICAL

## Rear Location



V01A3MY

TYPICAL

### **WARNING**

Do not tow this vehicle behind a car or other vehicle.



# ***MAINTENANCE INFORMATION***

# MAINTENANCE CHART

The maintenance is very important, if you are not familiar with safe service practices and adjustment procedures, see your authorized Bombardier ATV dealer.

LUBRICATION AND MAINTENANCE CHART  I: Inspect, verify, clean, adjust, lubricate, replace if necessary C: Clean L: Lubricate R: Replace	INITIAL 10 h INSPECTION OR 250 km (150 m.) ①	EVERY				TO BE PERFORMED BY
		25 h OR 625 km (388 m.)	50 h OR 1250 km (777 m.)	100 h OR 1 YEAR OR 2500 km (1553 m.)	200 h OR 2 YEARS OR 5000 km (3107 m.)	
<b>ENGINE/TRANSMISSION</b>						
Engine/transmission oil and filter ④	R		R			Customer
Engine/transmission oil strainer cleaning					C	Customer
Engine mount fasteners	I			I		Dealer
Exhaust system	I			I		Dealer
Spark arrester				C		Customer
Condition of seals	I			I		Dealer
Coolant ④	I		②		R	Customer
Radiator cap/cooling system pressure test	I				I	Dealer
Radiator condition/cleanliness (air ducts and radiator fins) ③	I		I			Customer
Rewind starter rope condition				I		Dealer
Clutch and transmission operation				I		Dealer
<b>FUEL SYSTEM</b>						
Air filter ④		C ③		R ③		Customer
Fuel lines and connections	I			I		Dealer
Fuel tank strainer					R	Dealer
Carburetor	I			I		Dealer
<b>ELECTRICAL SYSTEM</b>						
Spark plugs ⑤	I			R		Dealer
Battery electrolyte level/connections/vent condition	I		I			Customer
Wiring harnesses, cables and lines	I			I		Dealer
Condition of ignition switch and start/stop switch ④	I			I		Customer
Condition of lighting system (HI/LO intensity, brake light, headlight aiming, etc.) ④	I			I		Customer
<b>DRIVE TRAIN</b>						
Drive shaft boot and protector ④	I	I				Customer
Drive shaft joint			I			Dealer
Front/rear propeller shaft joint	I		L			Dealer
Wheel bearings condition ③				I		Dealer
Front differential and rear axle oil, seals and vent	I		I		R	Dealer

LUBRICATION AND MAINTENANCE CHART	INITIAL 10 h INSPECTION OR 250 km (150 m.) ①	EVERY				TO BE PERFORMED BY
		25 h OR 625 km (388 m.)	50 h OR 1250 km (777 m.)	100 h OR 1 YEAR OR 2500 km (1553 m.)	200 h OR 2 YEARS OR 5000 km (3107 m.)	
<b>I:</b> Inspect, verify, clean, adjust, lubricate, replace if necessary <b>C:</b> Clean <b>L:</b> Lubricate <b>R:</b> Replace						
<b>STEERING/CONTROL SYSTEMS</b>						
Handlebar fasteners				I		Dealer
Throttle/housing/cable ④	I		I			Customer
Choke condition ④	I		I			Customer
Steering system ③	I			I		Dealer
Tie rod ends ③			I			Dealer
Wheel nuts/studs	I		I			Customer
Wear/pressure of tires ④	EVERY RIDE					Customer
Front wheel alignment	I			I		Dealer
<b>SUSPENSION</b>						
Swing arm ④				I		Dealer
Shock absorber ④			I			Dealer
A-arm lubrication			I			Customer
<b>BRAKE</b>						
Brake fluid front/rear ④	I	I			R	Dealer
Brake cable	I		I			Dealer
Brake pad ③		I				Dealer
Brake system (discs, hoses, etc.) ③				I		Dealer
<b>BODY/FRAME</b>						
Grab handles inspection	EVERY RIDE					Customer
Backrest inspection	EVERY RIDE					Customer
Seat fasteners	EVERY RIDE					Customer
Engine compartment	C		C			Customer
Skid plate	I		I			Customer
Frame				I		Dealer
Hitch/trailer ball condition (if installed)	I		I			Customer
Chassis fasteners			I			Customer
Front storage compartment cover/seat latches ④			I			Customer
Vehicle cleaning and protection			C			Customer

① To be performed by an authorized Bombardier ATV dealer. The initial maintenance is very important and must not be neglected.

② Every 50 hours, check coolant strength.

③ More often under severe use such dusty area, sand, snow, wet or muddy conditions.

④ Pre-ride inspection item.

⑤ Make sure that the spark plug gap is correct.

# MAINTENANCE

While reading this *Operator's Guide*, remember that:

## WARNING

Indicates a potential hazard that, if not avoided, could result in serious injury or death.

## WARNING

Unless otherwise specified, engine should not be running for all maintenance procedures.

## WARNING

Should removal of a locking device (e.g. lock tabs, self-locking fasteners, etc.) be required when undergoing disassembly/assembly, always replace with a new one.

The following covers the maintenance items that can be performed by the customer if desired. Other items found in maintenance chart must be performed by an authorized Bombardier ATV dealer.

**NOTE:** Among other things, this section gives the procedures to replace the liquids. Refer to LIQUIDS for procedures to check levels and refill.

## Engine/Transmission

### Oil Change and Oil Filter Replacement

Oil and filter are to be replaced at the same time. Oil change should be done with a warm engine.

## WARNING

The engine oil can be very hot. Wait until engine oil is warm.

- Ensure vehicle is on a level surface.
- Clean the drain plug area.
- Remove dipstick.

Place a drain pan under the engine drain plug area.

Unscrew drain plug.

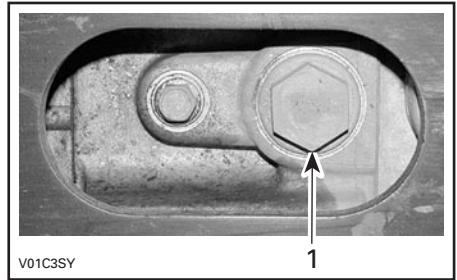

1. Oil drain plug

Wait enough time to allow oil to flow out of oil filter.

Carefully unscrew oil filter and as soon as it can be removed from the engine, turn it upright. Discard filter.

**NOTE:** Be sure that the old filter O-ring is removed.

**CAUTION:** Only use Bombardier high pressure filter or suitable equivalent. The Bombardier filter is specifically designed for this engine. This filter does not operate at the same pressure as other brands. Using a non-recommended filter may cause serious engine/transmission damage. See an authorized Bombardier ATV dealer.

Lubricate the O-ring on the filter with engine oil. Install the new filter then screw one full turn after O-ring contact.

Wipe out any oil spillage on engine.

Remove skid plate.

Remove oil strainer cover and oil collector, located near drain plug, then clean oil strainer.

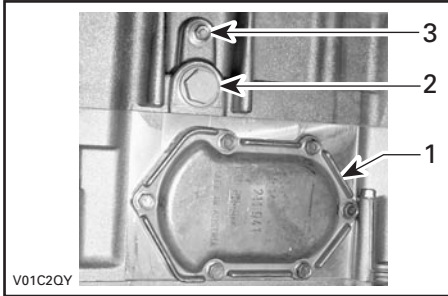

1. Oil strainer cover
2. Oil plug
3. Coolant plug

To clean oil strainer, use a solvent then dry with compressed air.

**⚠ WARNING**

**Always wear eye protection and gloves.**

Reinstall oil strainer, oil collector and oil strainer cover.

Change gasket on drain plug. Clean gasket area on engine and drain plug then reinstall plug. Refill engine at the proper level with the recommended oil. Refer to SPECIFICATIONS for capacity.

Start engine and let idle for a few minutes. Ensure oil filter area and drain plug areas are not leaking.

Stop engine. Wait a while to allow oil to flow down to crankcase then check oil level. Refill as necessary.

Dispose of oil as per your local environmental regulations.

### Coolant Replacement

**⚠ WARNING**

**To prevent burning yourself, do not remove the radiator cap or loosen the engine drain plug if the engine is hot.**

Turn the radiator cap counterclockwise and remove it.

Remove the drain plug under engine and drain the coolant into a suitable container.

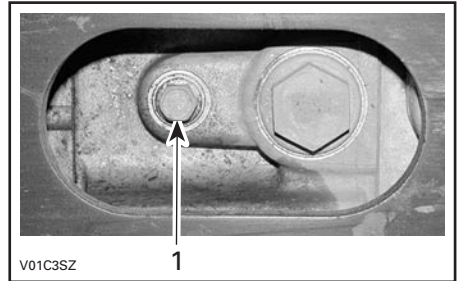

1. Cooling drain plug

Lift the rear of vehicle, about 2 or 3 inches, then remove the screw on the top of thermostat housing.

Drain the system completely and reinstall the drain plug.

Pinch hose between radiator and thermostat housing with a large hose pincher (P/N 529 032 500).



Fill the radiator until the coolant comes out by the thermostat housing hole. Install the bleeding screw then remove the hose pincher.

Complete the radiator filling.

Check the level in the coolant reservoir and refill if necessary.

Run engine at idle with the radiator cap off. Slowly add additional coolant if necessary.

At this point, wait until engine reaches normal operating temperature. Depress the throttle lever two or three times; then add coolant if required.

Install radiator cap. Inspect all connections for leaks and check coolant level in the reservoir.

### Valve Adjustment

Valve adjustment is not required on this engine.

### Spark Arrester

The muffler must be periodically purged of accumulated carbon.

## WARNING

Never run engine in an enclosed area. Never perform this operation immediately after the engine has been run because exhaust system is very hot. Make sure that there are no combustible materials in the area. Wear eye protection and gloves. Never stand behind the vehicle while purging exhaust system. Respect all applicable laws and regulations.

Select a well-ventilated area and make sure the muffler is cool.

Place transmission on PARK position.

Remove the clean-out plug from muffler.

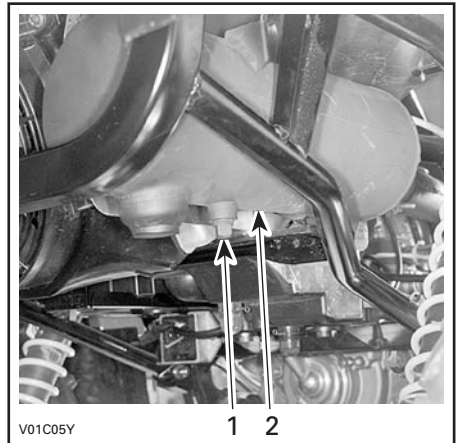

### TYPICAL

1. Clean-out plug
2. Muffler

Block the end of muffler with a shop rag and start engine.

Momentarily increase engine RPM several times to purge accumulated carbon out of the muffler.

Stop engine and allow muffler to cool. Reinstall the clean-out plug.

### Radiator

Periodically check the radiator area and the air ducts for cleanliness. Ensure air ducts are unobstructed to allow air flow to the radiator.

An access hole is available to inspect the radiator condition and to give access for cleaning.

Remove seat.

Pull on the circumference of the access plug and remove plug.

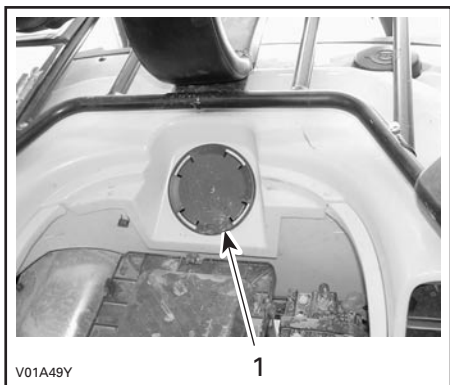

1. Access plug

Inspect radiator fins. They must be clean, free of mud, dirt, leaves and any other deposit that would prevent the radiator to cool properly.

Remove the deposits as much as you can with your hands. If water is available in proximity, try rinsing the radiator fins.

If available, use a garden hose to rinse the radiator fins.

## **WARNING**

Never clean radiator with your hands when it is hot. Let the radiator cool down before cleaning.

**CAUTION:** Be careful not to damage the radiator fins when cleaning. Do not use any object/tool that could damage the fins. The fins are purposefully thin parts to allow efficient cooling. When hosing, use low pressure only.

Properly reinstall access plug and seat.

## **Air Intake System**

### **Air Filter Cleaning/Draining**

Periodically inspect air filter box drain tube for water or deposits.

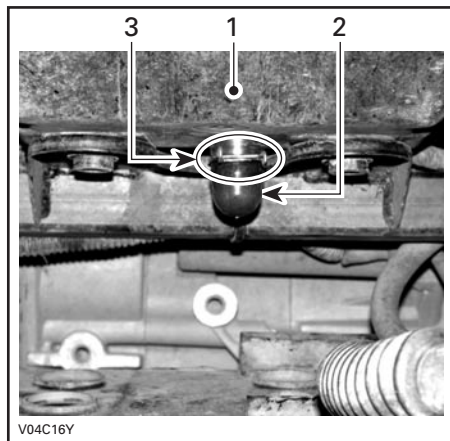

#### **TYPICAL**

1. Air filter box
2. Drain tube
3. Clamp

**NOTE:** If vehicle is used in dusty area, inspect more frequently than specified in MAINTENANCE CHART.

If water/deposits are found, squeeze and remove the clamp. Pull drain tube out.

**CAUTION:** Do not start engine when water is found in the drain tube.

When water/deposits are found, the air filter must be inspected/dried/replaced depending on its condition.

Remove air filter as explained below.

### **Air Filter Removal**

**CAUTION:** Never remove or modify any component in the air box. The engine carburetion is calibrated to operate specifically with these components. Otherwise, engine performance degradation or damage can occur.

Remove seat.

Release clamps and remove air filter box cover.

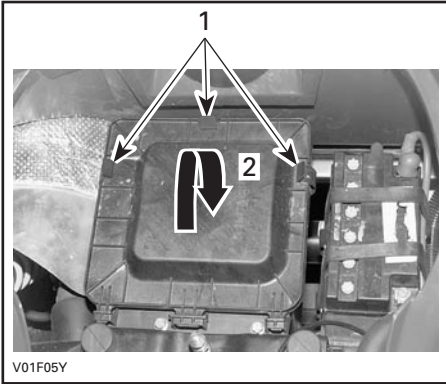

**TYPICAL**

1. Release clamps
2. Lift to remove

Loosen clamp and remove air filter.

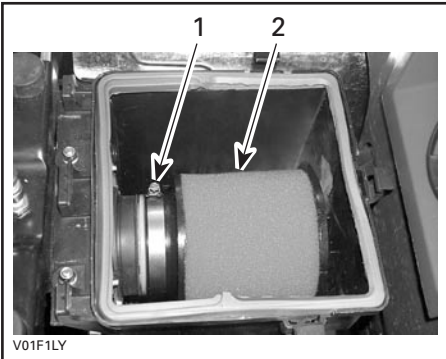

1. Clamp
2. Air filter

Pour air filter cleaning solution (P/N 293 600 059) into a bucket. Put the filter in to soak.

While filter soaks, clean inside the air box.

Rinse the filter with warm water until all cleaning solution disappears.

Then, let the filter dry completely.

When the filter is dried, re-oil with air filter oil (P/N 293 600 058).

**CAUTION:** Never remove or modify any component in the air box. Always use genuine parts when replacing air filter and foam. The engine carburetor is calibrated to operate specifically with these components. Otherwise, engine performance degradation or damage can occur.

**NOTE:** Slight dust may be cleaned using a low-pressure airgun. Blow compressed air backward of operating air flow.

**Air Filter Installation**

Properly reinstall removed parts in the reverse order of their removal.

**Electrical**

**Battery**

**⚠ WARNING**  
Never charge a battery while installed in vehicle.

Clean battery post with a wire brush. Apply dielectric grease on post to protect against oxidation.

**Fuses**

If a fuse is damaged, replace it by one of the same rating.

**CAUTION:** Do not use a higher rated fuse as this can cause severe damage.

Fuses are located in engine compartment on LH side of battery.

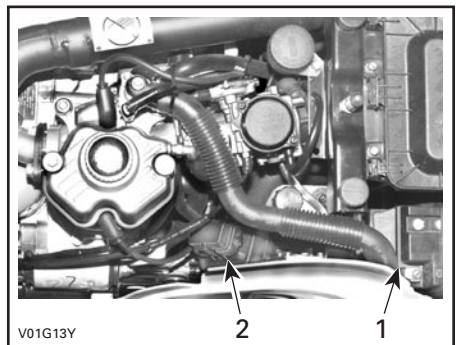

1. Battery
2. Fuse holder



Fuses are identified by a number located beside the fuse.

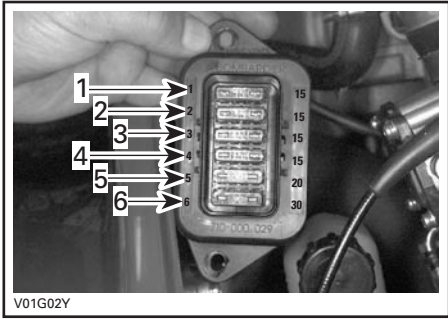

V01G02Y

1. Ignition system
2. Accessories (power outlet and auxiliary supply)
3. Solenoids
4. Fan
5. MPEM (Multi-Purpose Electronic Module)
6. Charging system

To remove fuse from holder, pull fuse out. Check if filament is melted.

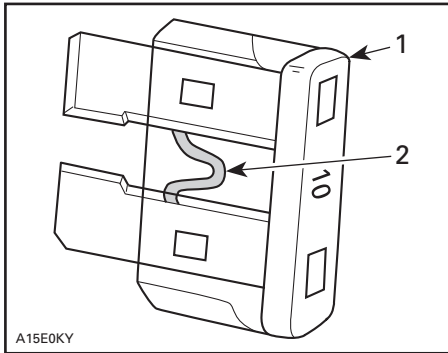

A15E0KY

**TYPICAL**

1. Fuse
2. Check if melted

**Headlight and Parking Light Bulbs Replacement**

**NOTE:** Always check light operation after replacement.

The headlight has two bulbs, the headlight bulb and the parking light bulb.

**Headlight Bulb**

To replace the headlight bulb, proceed as follows.

Disconnect the headlight connector.

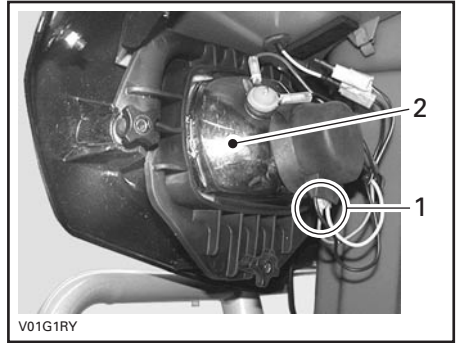

V01G1RY

1. Headlight connector
2. Headlight housing

**NOTE:** On the following illustrations, the headlight has been removed for a better comprehension.

Remove the protective rubber sleeve.



V01G1SY

Unlock the bulb socket.

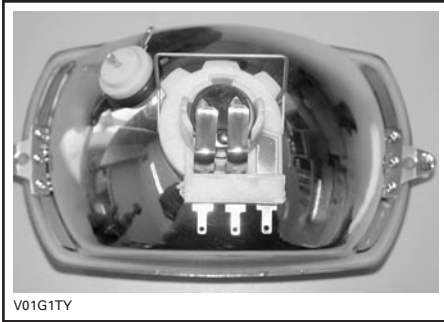

Remove the socket snap. Open the both side of socket snap.

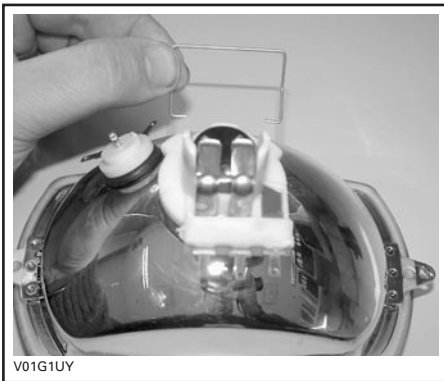

Push bulb in and hold while turning counterclockwise to release.

Install the new bulb by first pushing in while turning clockwise.

Install the socket into the headlight housing. Align holes in the housing with the socket slots.

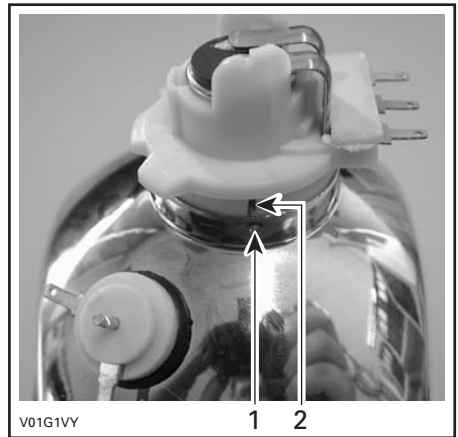

1. *Housing hole*
2. *Socket slot*

Install the socket snap.

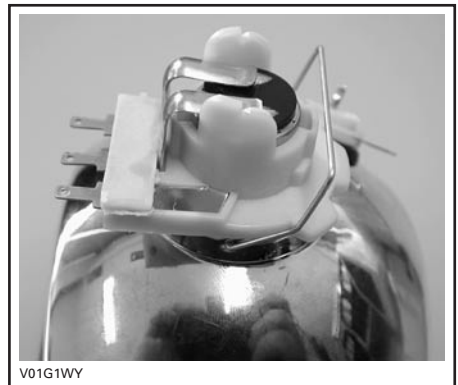

Install the protective rubber sleeve and connect the headlight connector.

**NOTE:** Take care do not pry the socket terminals.

## Parking Light Bulb

To replace the parking light bulb, proceed as follows.

Disconnect the both connectors on the parking light socket.

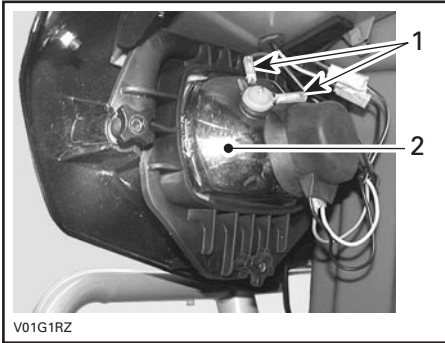

1. Parking light connectors
2. Headlight housing

**NOTE:** The headlight has been removed to ease the comprehension.

Pull the parking light socket out of headlight housing.

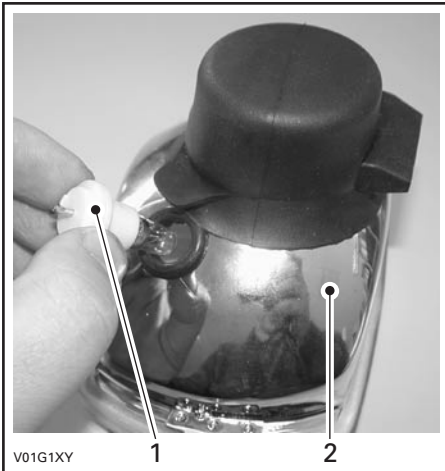

1. Parking light socket
2. Headlight housing

Push bulb in and hold while turning counterclockwise to release.

Install the new bulb by first pushing in while turning clockwise.

Put back the parking light socket in the headlight housing and connect the connectors.

Adjust beam aiming as follows:

Turn knobs to adjust beam height and side orientation to your convenience. Adjust both headlights evenly.

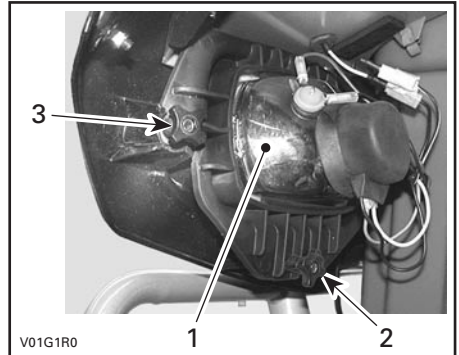

1. Headlight
2. Beam height adjustment
3. Beam side adjustment

## Taillight Bulb and Parking Light Bulb Replacement

Unscrew lens screws to expose bulbs.

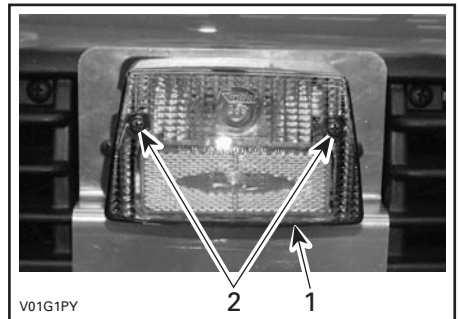

1. Lens
2. Screws

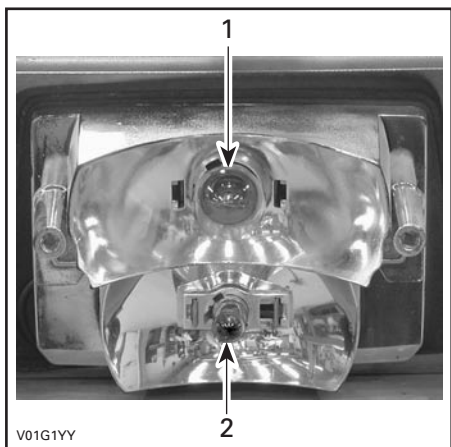

1. Taillight bulb
2. Parking light bulb

**NOTE:** Use the same procedure for both bulbs.

Push bulb in and hold while turning counterclockwise to release.

Install the new bulb by first pushing in while turning clockwise.

### Turn Signal Bulb Replacement

Remove the screw retaining the lens to the housing.

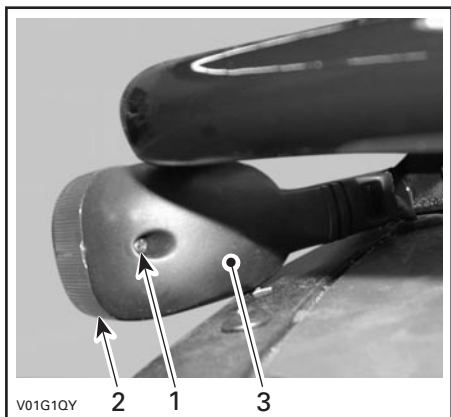

#### REAR OF TURN SIGNAL HOUSING

1. Screw
2. Lens
3. Turn signal housing

Push and turn the bulb counterclockwise. Pull the bulb to remove it.

Install the new bulb by first pushing in while turning clockwise. Check light operation.

Reinstall the lens.

### Indicator Light Replacement

If one LED is burnt in the indicator light cluster, see an authorized Bombardier ATV dealer for replacement of the light cluster.

### Speedometer Bulbs

The speedometer is lighted with LEDs. If one LED burns, replace the speedometer. The LEDs are not available separately.

### Drive Train

#### Drive Shaft Boot/Protector

##### Inspection

Visually inspect drive shaft protectors and boot conditions. Check protectors for damage or rubbing against shafts. Check boots for cracks, tears, leaking grease etc. Repair or replace damaged parts as necessary.

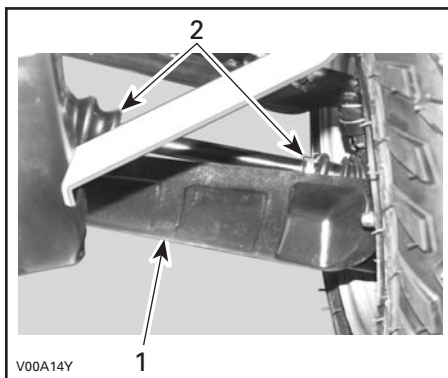

1. Drive shaft protector
2. Drive shaft boots

## Wheel

Occasionally, wheel nuts should be removed to apply anti-seize lubricant on studs to ease further removal. This is particularly important when vehicle is used in salt-water environment or in mud. Remove one nut at a time, lubricate then retorque.

## Wheel Bearing Condition

Push and pull the wheels from the upper edge to feel the play. See an authorized Bombardier ATV dealer if there is any play.

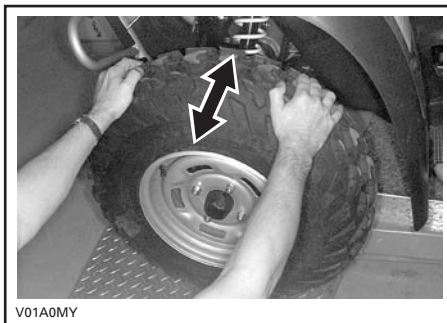

## Tires/Wheels

### Tire Pressure

#### **WARNING**

Tire pressure greatly affects vehicle handling and stability. Underpressure may cause tire to deflate and rotate on wheel. Overpressure may burst the tire. Always follow recommended pressure. Since tires are low-pressure types, a manual pump should be used.

Check pressure when tires are "cold" before using the vehicle. Tire pressure changes with temperature and altitude. Recheck pressure if one of these conditions has changed.

For your convenience, a pressure gauge is supplied in tool box.

TIRE PRESSURE			
UP TO 290 KG (640 LB)	MAXIMUM	FRONT	REAR
		48 kPa (7 PSI)	
UP TO 290 KG (640 LB)	MINIMUM	35 kPa (5 PSI)	

Although the tires are specifically designed for off-road use, a flat may still occur. Therefore, it is recommended to carry a tire pump and a repair kit.

### Tire/Wheel Condition

Check tire for damage and wear. Replace if necessary.

Do not make a tire rotation. The front and rear tires have a different size. The tires are directional and their rotation must be kept in a specific direction for proper operation.

### Wheel Removal

Loosen nuts then lift vehicle. Place a support under vehicle. Remove nuts then remove wheel.

At installation, it is recommended to apply anti-seize lubricant on threads. Gently tighten nuts in a criss-cross sequence then apply a final torque of 75 N•m (55 lbf•ft).

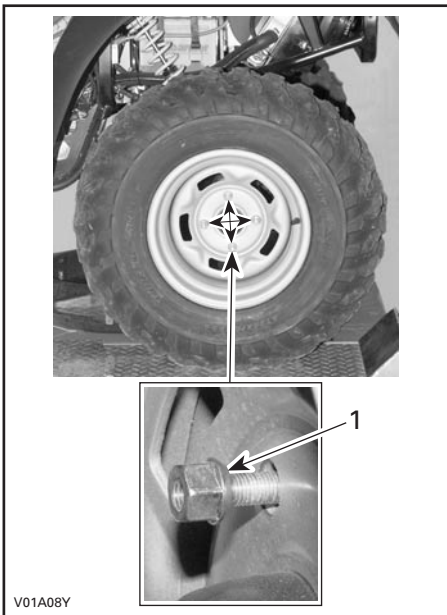

1. Taper side of nut

**CAUTION:** Always use the recommended wheel nuts (P/N 705 400 013). Using a different nut could cause damages to the rim.

## Steering/Control Systems

### Throttle Cable Lubrication

The throttle cable must be lubricated with cable lubricant (P/N 293 600 041).

#### **WARNING**

Using another lubricant could cause bad working of throttle lever/cable.

Open the throttle lever housing.

Separate the housing. Slide rubber protector back to expose throttle cable adjuster.

Screw in the throttle cable adjuster.

Remove the cable from the throttle lever housing.

**NOTE:** Slide cable in clip slot and remove the end of cable from clip.

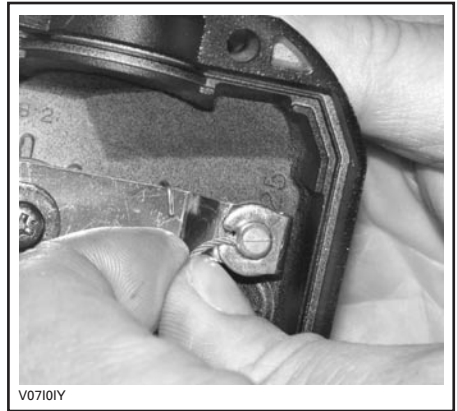

#### **TYPICAL**

Remove the carburetor side cover.

Insert the needle of lubricant can in the end of throttle cable adjuster.

#### **WARNING**

Always wear eye protection and gloves when you lubricate a cable.

**NOTE:** Place a rag around the throttle cable adjuster to prevent the lubricant splash.

Add lubricant until it runs out at carburetor end of the throttle cable.

Reinstall and adjust the cable.

### Throttle Lever Adjustment

Slide rubber protector back to expose throttle cable adjuster.

Loosen lock nut then turn the adjuster to obtain correct throttle lever free play.

**NOTE:** Measure throttle free play at the tip of throttle lever.

Tighten lock nut and reinstall protector.

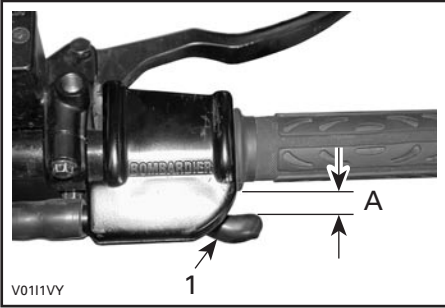

- 1. Throttle lever
- A. 3 to 6 mm (1/8 to 7/32 in)

With the transmission lever on PARK position, start the engine. Check if the throttle cable is adjusted correctly by turning handlebar fully right then fully left. If the engine RPM increases, re-adjust the throttle lever free play.

## Suspension

### A-Arms Lubrication

Lubricate front A-arms. Use synthetic grease (P/N 293 550 033). There is two grease fittings on the upper A-arm and two on the lower A-arm (underneath).

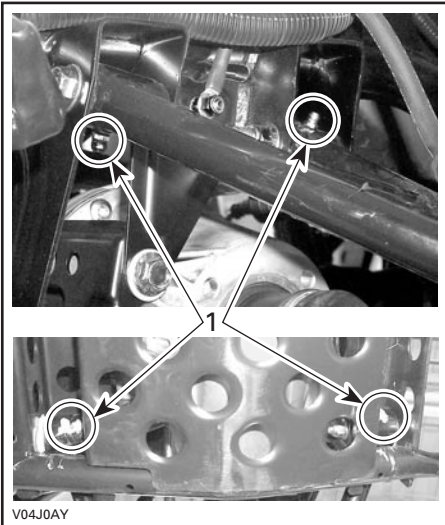

- 1. Grease fittings

## Inspection

Inspect shock absorber for oil leaks and fasteners for tightness. See an authorized Bombardier ATV dealer as necessary.

## Adjustment

### Rear Shocks

#### **WARNING**

Left and right adjusting cams must always be set at the same position. Never adjust one adjusting cam only. Uneven adjustment can cause poor handling and loss of stability, which could lead to an accident.

### Preload Adjustment

Adjust spring preload by turning adjusting cam accordingly with the adjusting wrench in vehicle tool box.

Turn the adjusting cams clockwise for a firmer ride and rough road condition or when carrying cargo or pulling a trailer.

Turn the adjusting cams counterclockwise for a light load and a smooth road condition.

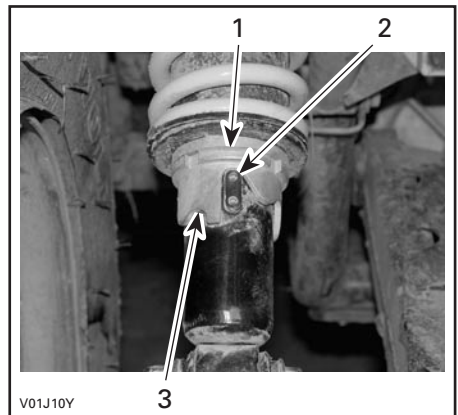

- 1. Adjusting cams
- 2. Smooth adjustment
- 3. Hard adjustment

## **Brake**

### **Front Brake**

The front brakes are hydraulic disc types. These brakes are self-adjusting and require no adjustment.

### **Rear Brake**

The rear brake employs two systems. The first system used a cable, an adjustment is necessary, see an authorized Bombardier ATV dealer. The second system is hydraulic and require no adjustment. The systems are linked together for an higher efficiency.

### **Brake Cable Lubrication**

Remove brake lever and lock (screw, nut and spring).

Remove cable from hand lever. To ease this operation, apply a force on the brake pedal to loosen the cable.

Put the cable luber (P/N 529 035 738) on the cable.

Insert the needle of the spray can in the hole.

Spray a small quantity of silicone lubricant (P/N 293 600 041) then press the brake pedal to move the brake cable. Repeat this procedure until the silicone lubricant exits the other end of the cable.

## **Body/Frame**

### **Engine Compartment**

Check engine compartment for any damage and leaks. Ensure all hose clamps are properly secured and no hose is cracked, kinked or otherwise damaged.

Inspect muffler, battery and reservoir fastening devices. Check electrical connections for corrosion and tightness.

Replace or have damaged parts repaired.

## **Skid Plate Condition**

Check tightness of fasteners and condition of plate for cracks or other damage. Properly retighten fasteners as necessary and have skid plate replaced if damaged.

### **Hitch/Trailer Ball Condition**

Check tightness of fasteners and tightness/condition of trailer ball. Properly retighten as necessary and replace ball if worn.

### **Fasteners**

Check fastener condition and tightness on the vehicle. Retighten as required.

### **Seat Latch**

Remove seat and check latch mechanism and pin for wear. See an authorized Bombardier ATV dealer for parts replacement if damaged.

### **Front Storage Compartment Latch**

Check latch condition. See an authorized Bombardier ATV dealer for parts replacement if damaged.

## **Vehicle Cleaning and Protection**

Never use a high pressure washer to clean the vehicle **USE LOW PRESSURE ONLY (like a garden hose)**. A high pressure can cause electrical or mechanical damages.

Painted parts which are damaged should be properly repainted to prevent rust.

When required, wash the body with hot water and soap (only use mild detergent). Apply non-abrasive wax.

**CAUTION:** Never clean plastic parts with strong detergent, degreasing agent, paint thinner, acetone, etc.



# TROUBLESHOOTING

<b>SYMPTOM: <i>Engine does not turn</i></b>	
<b>POSSIBLE CAUSES</b>	<b>WHAT TO DO</b>
1. Ignition switch is in the OFF position.	Place switch to ON position.
2. Transmission is not set on the PARK or NEUTRAL.	Set transmission either in PARK or in NEUTRAL or press any brake lever.
3. Burnt fuse.	Check MPEM and solenoids fuses condition.
4. Weak battery or loose connections.	Check charging system fuse. Check connections and terminals condition. Have the battery checked. Contact an authorized Bombardier ATV dealer.

<b>SYMPTOM: <i>Engine turns over but fails to start</i></b>	
<b>POSSIBLE CAUSES</b>	<b>WHAT TO DO</b>
1. Burnt fuse.	Check ignition fuse condition.
2. Mixture not rich enough to start cold engine.	Check fuel tank level and check starting procedure, particularly use of the choke.  <b>NOTE:</b> Below - 15°C (5°F) the use of fuel primer (optional) is required. Also, it is recommended to add gas line antifreeze.
3. Flooded engine (spark plugs wet when removed).	Refer to SPECIAL PROCEDURES.
4. No fuel to the engine (spark plugs dry when removed).	Check fuel tank level; turn fuel valve to ON (also try on RES). A failure of the fuel pump or carburetor may have occurred. Contact an authorized Bombardier ATV dealer.
5. Spark plug/ignition (no spark).	Check ignition fuse condition. Remove spark plugs then reconnect to spark plug caps. Check that ignition switch and/or engine stop switch(es) is/are at the ON position. Start engine with spark plugs grounded to engine away from spark plug holes. If no spark appears, replace spark plugs. If trouble persists, contact an authorized Bombardier ATV dealer.
6. Engine compression.	As the engine is pulled over with the rewind starter, "cycles" of resistance should be felt as piston goes past top dead center. If no pulsating resistance is felt, it suggests a major loss of compression. Contact an authorized Bombardier ATV dealer.

<b>SYMPTOM: <i>Engine lacks acceleration or power</i></b>	
<b>POSSIBLE CAUSES</b>	<b>WHAT TO DO</b>
1. Fouled or damaged spark plug.	Check item ENGINE TURNS OVER BUT FAILS TO START.
2. Lack of fuel to engine.	Check item ENGINE TURNS OVER BUT FAILS TO START.
3. Carburetor adjustments.	Contact an authorized Bombardier ATV dealer.
4. Engine is overheating.	Check ENGINE OVERHEAT IN SPECIAL PROCEDURES. If overheating persists, contact an authorized Bombardier ATV dealer.
5. Air filter box plugged or dirty.	Check air filter and clean if necessary. Check deposits in air box drain. Check the position of the air intake tube, reinstall properly if necessary.

<b>SYMPTOM: <i>Engine backfire</i></b>	
<b>POSSIBLE CAUSES</b>	<b>WHAT TO DO</b>
1. Exhaust system leakage.	Contact an authorized Bombardier ATV dealer.
2. Engine is running too hot.	See ENGINE LACKS ACCELERATION OR POWER.
3. Ignition timing is incorrect or there is an ignition system failure.	Contact an authorized Bombardier ATV dealer.
4. Improper carburetor setting.	Contact an authorized Bombardier ATV dealer.

<b>SYMPTOM: <i>Engine misfire</i></b>	
<b>POSSIBLE CAUSES</b>	<b>WHAT TO DO</b>
1. Fouled/damaged/worn spark plugs.	Clean/verify spark plugs and heat range. Replace as required.
2. Water in fuel.	Drain fuel system and refill with fresh fuel.

<b>SYMPTOM: <i>Vehicle cannot reach full speed</i></b>	
<b>POSSIBLE CAUSES</b>	<b>WHAT TO DO</b>
1. Engine.	See ENGINE LACKS ACCELERATION OR POWER.
2. Parking brake.	Ensure brake lever lock is completely removed.
3. Air filter box plugged or dirty.	Check air filter and clean if necessary. Check deposits in air box drain. Check the position of the air intake tube, reinstall properly if necessary.

**SYMPTOM: Engine indicator light irregularly flashes at idle speed****POSSIBLE CAUSES****WHAT TO DO**

1. Engine idle is set too low.

Contact an authorized Bombardier ATV dealer.

**SYMPTOM: Transmission does not shift smoothly****POSSIBLE CAUSES****WHAT TO DO**

1. Engine/transmission oil level is low.

Refill engine with recommended oil at the proper level.

2. Transmission shifting system.

Try depressing the throttle lever more while shifting.

3. Improper oil type.

Drain oil in engine and use recommended oil only.

4. Transmission.

See an authorized Bombardier ATV dealer.

**SYMPTOM: Transmission lever is hard to move****POSSIBLE CAUSES****WHAT TO DO**

1. Transmission gears are in a position that prevents the transmission lever to work.

Rock the vehicle back and forth to move the gears in the transmission and allow the transmission lever to be set.

2. Engine idle speed is set too high.

Adjust the idle speed. Refer to the specification.

**SYMPTOM: Automatic mode does not work****POSSIBLE CAUSES****WHAT TO DO**

1. Multi-function switch problem.

Contact an authorized Bombardier ATV dealer.

2. TPS sensor is defect.

Check TPS connector on carburetor. If the connection is good, contact an authorized Bombardier ATV dealer.

3. Engine.

Contact an authorized Bombardier ATV dealer.

**SYMPTOM: The RPM increases but the vehicle does not move****POSSIBLE CAUSES****WHAT TO DO**

1. Transmission is set on the PARK or NEUTRAL.

Move the transmission lever to R, H or L position.

# SPECIFICATIONS

VEHICLE MODEL		TRAXTER® MAX
<b>ENGINE</b>		
Type	BOMBARDIER-ROTAX, 4-stroke. Longitudinal mount, liquid cooled, OHV	
Number of cylinder	Single cylinder	
Number of valve	2 valves with hydraulic lifters (no adjustment)	
Displacement	498 cc (30.4 cu. in)	
Bore	Standard	89 mm (3.5 in)
Stroke	80 mm (3.15 in)	
Compression ratio	9:1	
Lubrication	Wet sump with replaceable oil filter (lubrication of engine and transmission simultaneously)	
Oil filter	BOMBARDIER-ROTAX	
Decompressor	Automatic	
Exhaust system	Nelson, stainless steel, USDA approved	
Air filter	2 stage foam filter	
<b>TRANSMISSION</b>		
Clutch	1 centrifugal and 1 multi-disc hydraulically controlled	
Transmission	Dual range (HI-LO) with park, neutral and reverse. 5 speeds. Electronically controlled hydraulic shift. Limited vehicle reverse speed	
<b>COOLING</b>		
Type	Liquid cooled	
Radiator	Rear mounted with thermostatic fan	
<b>CARBURETION</b>		
Carburetor make and type	Mikuni BSR33. Constant depression type with manual choke and ECS (Enricher Coasting System)	
Choke plunger position	Variable	
Idle speed	± 100	1100 RPM
Fuel pump make and type	Mikuni, external (vacuum-operated)	

VEHICLE MODEL		TRAXTER® MAX	
<b>ELECTRICAL</b>			
Magneto generator make and type		Denso, 400 W @ 6000 RPM	
Ignition type		IDI (Inductive Discharge Ignition)	
Ignition timing		Not adjustable	
Engine RPM limiter		7700 RPM (any gear in forward)	
Vehicle speed limiter		15 km/h (9 MPH) in reverse	
Spark plug make and type		NGK DR8EA	
Number of spark plug		2	
Spark plug gap		0.6 to 0.7 mm (.024 to .027 in)	
Battery		12 V, 19 A (20 A, optional). Electrolyte type battery	
Starting system		Electric start and manual rewind starter. Start in any gear (with brake applied)	
Headlight		2 x 55 W, H4703	
Taillight		8/27 W, 1157	
Pilot lamp cluster		LEDS, 0.7 V approx.	
<b>FUSES</b>			
Ignition (no. 1)		15 A	
Accessories (no. 2)		15 A (power outlet and auxiliary supply)	
Solenoids (no. 3)		15 A	
Fan (no. 4)		15 A	
MPEM (Multi-Purpose Electronic Module) (no. 5)		20 A	
Charging system (no. 6)		30 A	
<b>DRIVE TRAIN</b>			
Front differential		Shaft driven/single auto-lock differential (shear pump)	
Rear axle		Shaft driven/solid axle	
<b>SUSPENSION</b>			
Front	Type	Independent suspension — double A-arm	
	Travel	178 mm (7 in)	
Rear	Type	Rigid swing-arm	
	Travel	190.5 mm (7.5 in)	
<b>TIRES</b>			
Pressure	Up to 290 kg (640 lb)	Front	35 kPa (5 PSI) minimum, 48 kPa (7 PSI) maximum
		Rear	35 kPa (5 PSI) minimum, 48 kPa (7 PSI) maximum
Size	Front		25 x 8 — 12 TRAILWOLF
	Rear		26 x 10 — 12 TRAILWOLF

VEHICLE MODEL		TRAXTER® MAX
<b>WHEELS</b>		
Size	Front	12 x 6.5
	Rear	12 x 8
Wheel nut torque		75 N•m (55 lbf•ft)
<b>BRAKES</b>		
Front		Hydraulic, 2 drilled discs
Rear		Hydraulic, 1 drilled disc
Parking		Park through transmission. LH brake lever includes a lock
<b>LOADING CAPACITY</b>		
Front rack		40 kg (90 lb) includes front storage tray
Rear rack		80 kg (175 lb) includes tongue load
Total vehicle load allowed		290 kg (640 lb) includes operator, all other loads and added accessories
GVWR (Gross Vehicle Weight Rating)		682 kg (1500 lb)
Towing capacity		500 kg (1100 lb)
Tongue capacity		14 kg (30 lb) included with rear rack
Front storage tray		10 kg (22 lb) included with front rack
<b>DIMENSIONS</b>		
Dry mass		361 kg (795 lb)
Overall length		2.33 m (92 in)
Overall width		1.20 m (47 in)
Overall height		1.33 m (52 in)
Wheel base		1.55 m (61 in)
Wheel track	Front	992 mm (39 in)
	Rear	940 mm (37 in)
Turning radius		2.36 m (93 in)
Ground clearance	Front and under engine	244 mm (9.6 in)
	Rear axle	188 mm (7.4 in)
Weight distribution (front/rear)		47/53%

VEHICLE MODEL		TRAXTER® MAX
<b>LIQUIDS</b>		
Oil type (engine and transmission)		SAE, 4-stroke mineral-based engine oil. API classification SG,SH or SJ or Bombardier synthetic oil. <b>Do not use other synthetic oil, synthetic blend oil or special additive.</b> Refer to OIL VISCOSITY CHART for proper grade
Coolant		Ethylene-glycol/water mix (50% coolant, 50% water). Use coolant specifically designed for aluminum engines
Fuel	Type	Regular unleaded gasoline
	Octane	87 (R + M)/2 or higher
Differential	Front/rear	Synthetic polyolester oil 75W90 (API GL-5)
Hydraulic brake		Brake fluid, DOT 4
Propeller shaft joint grease		Shell, Alvania EP-2 only
<b>CAPACITIES</b>		
Vehicle range		Approximately 10 hours depending on many factors such as temperature, operating conditions and load
Fuel tank		20 L (5.3 U.S. gal) including approximately 6 L (1.6 U.S. gal) reserve
Engine/transmission oil		Oil change with filter: 2.5 L (2.65 quarts). Total: 3 L (3.17 quarts)
Coolant		3 L (3.17 quarts)
Differential	Front	650 mL (22 U.S. oz)
	Rear	300 mL (10 U.S. oz)

Because of our ongoing commitment to product quality and innovation, Bombardier reserves the right, at any time, to make changes in design and specifications and/or to make additions to, or improvements in its products without imposing any obligation upon itself to install them on its products previously manufactured.

# SI\* METRIC INFORMATION GUIDE

## BASE UNITS

DESCRIPTION	UNIT	SYMBOL
length .....	meter .....	m
mass .....	kilogram .....	kg
force .....	newton .....	N
liquid .....	liter .....	L
temperature .....	Celsius .....	°C
pressure .....	kilo pascal .....	kPa
torque .....	newton-meter .....	N•m
land velocity .....	kilometer per hour .....	km/h

## PREFIXES

PREFIX	SYMBOL	MEANING	VALUE
kilo .....	K .....	one thousand .....	1000
centi .....	C .....	one hundredth of .....	0.01
milli .....	m .....	one thousandth of .....	0.001
micro .....	μ .....	one millionth of .....	0.000001

## CONVERSION FACTORS

TO CONVERT	TO ①	MULTIPLY BY
in .....	mm .....	25.4
in .....	cm .....	2.54
in <sup>2</sup> .....	cm <sup>2</sup> .....	6.45
in <sup>3</sup> .....	cm <sup>3</sup> .....	16.39
ft .....	m .....	0.3
oz .....	g .....	28.35
lb .....	kg .....	0.45
lbf .....	N .....	4.4
lbf•in .....	N•m .....	0.11
lbf•ft .....	N•m .....	1.36
lbf•ft .....	lbf•in .....	12
PSI .....	kPa .....	6.89
imp. oz .....	U.S. oz .....	0.96
imp. oz .....	mL .....	28.41
imp. gal .....	U.S. gal .....	1.2
imp. gal .....	L .....	4.55
U.S. oz .....	mL .....	29.57
U.S. gal .....	L .....	3.79
MPH .....	km/h .....	1.61
Fahrenheit .....	Celsius .....	(°F - 32) ÷ 1.8
Celsius .....	Fahrenheit .....	(°C × 1.8) + 32
hp .....	kW .....	.75

\* The international system of units abbreviates SI in all languages.

① To obtain the reverse sequence, divide by the given factor. To convert **milli-meters to inches**, divide by 25.4.

**NOTE:** Conversion factors are rounded off to 2 decimals for easier use.



# ***WARRANTY***

---

# **BOMBARDIER LIMITED WARRANTY INTERNATIONAL: 2003 BOMBARDIER® TRAXTER® MAX**

## **1. SCOPE OF THE LIMITED WARRANTY**

BOMBARDIER INC. (hereinafter “Bombardier”), warrants its 2003 Bombardier® Traxter® MAX from defects in material or workmanship for the period described below.

All genuine BOMBARDIER parts and accessories, installed by an authorized BOMBARDIER distributor/dealer (as hereinafter defined) at the time of delivery of the 2003 Bombardier® Traxter® MAX, carry the same warranty as that of the vehicle.

### **Carlisle Tire & Wheel Company**

(Traxter and Quest tires)

23 Windham Boulevard

Aiken, SC 29805

#### *Warranty Information:*

In USA: 1 800 260-7959

In Canada: 1 800 265-6155

In Quebec: 1 877 997-4999

Use of the product for racing or any other competitive activity, at any point, even by a previous owner, will render this warranty null and void.

## **2. WARRANTY COVERAGE PERIOD**

This warranty will be in effect FROM THE DATE OF DELIVERY TO THE FIRST RETAIL CONSUMER or the date the product is first put into use, whichever occurs first and for a period of:

SIX (6) CONSECUTIVE MONTHS, for private use or commercial use owners.

The repair or replacement of parts or the performance of service under this warranty does not extend the life of this warranty beyond its original expiration date.

## **3. CONDITIONS TO HAVE WARRANTY COVERAGE**

This warranty coverage is available only on 2003 Bombardier® Traxter® MAX purchased as new and unused by its first owner from a BOMBARDIER distributor/dealer authorized to distribute Bombardier ATV products in the country in which the sale occurred (hereinafter “BOMBARDIER distributor/dealer”), and then only after the BOMBARDIER specified pre-delivery inspection process is completed and documented. Warranty coverage only becomes available upon proper registration of the product by an authorized BOMBARDIER distributor/dealer. Such limitations are necessary in order to allow BOMBARDIER to preserve both the safety of its products, and also that of its consumers and the public.

Routine maintenance outlined in this manual must be timely performed in order to maintain warranty coverage. BOMBARDIER reserves the right to make warranty coverage contingent upon proof of proper maintenance.

#### **4. WHAT TO DO TO OBTAIN WARRANTY COVERAGE**

The customer must notify a servicing BOMBARDIER distributor/dealer within two (2) days of the appearance of a defect, and provide it with reasonable access to the product and reasonable opportunity to repair it. The customer must also present to the authorized BOMBARDIER distributor/dealer, proof of purchase of the product and must sign the repair/work order prior to starting the repair in order to validate the warranty repair. All parts replaced under this limited warranty become the property of BOMBARDIER.

#### **5. WHAT BOMBARDIER WILL DO**

BOMBARDIER's obligations under this warranty are limited to, at its sole discretion, repairing parts found defective under normal use, maintenance and service, or replacing such parts with new genuine BOMBARDIER parts without charge for parts and labor, at any authorized BOMBARDIER distributor/dealer.

BOMBARDIER reserves the right to improve or modify products from time to time without assuming any obligation to modify products previously manufactured.

#### **6. EXCLUSIONS - ARE NOT WARRANTED**

- Normal wear and tear;
- Routine maintenance items, tune ups, adjustments;
- Damage caused by failure to provide proper maintenance and/or storage, as described in this manual ;
- Damage resulting from removal of parts, improper repairs, service, maintenance, modifications or use of parts not manufactured or approved by BOMBARDIER or resulting from repairs done by a person that is not an authorized servicing BOMBARDIER distributor/dealer;
- Damage caused by abuse, abnormal use, neglect or operation of the product in a manner inconsistent with the recommended operation described in this 2003 Bombardier® Traxter® MAX *Operator's Guide*;
- Damage resulting from accident, submersion, fire, theft, vandalism or any act of God;
- Operation with fuels, oils or lubricants which are not suitable for use with the product;
- Water or snow ingestion;
- Incidental or consequential damages, or damages of any kind including without limitation towing, storage, telephone, rental, taxi, inconvenience, insurance coverage, loan payments, loss of time, loss of income.

#### **7. LIMITATIONS OF LIABILITY**

THIS WARRANTY IS EXPRESSLY GIVEN AND ACCEPTED IN LIEU OF ANY AND ALL OTHER WARRANTIES, EXPRESSED OR IMPLIED, INCLUDING WITHOUT LIMITATION ANY WARRANTY OF MERCHANTABILITY OR FITNESS FOR A PARTICULAR PURPOSE. TO THE EXTENT THAT THEY CANNOT BE DISCLAIMED, THE IMPLIED WARRANTIES ARE LIMITED IN DURATION TO THE LIFE OF THE EXPRESS WARRANTY. INCIDENTAL AND CONSEQUENTIAL DAMAGES ARE EXCLUDED FROM COVERAGE UNDER THIS WARRANTY. SOME STATES/ PROVINCES DO NOT ALLOW FOR THE DISCLAIMERS, LIMITATIONS AND EXCLUSIONS IDENTIFIED ABOVE, AS A RESULT, THEY MAY NOT APPLY TO YOU. THIS WARRANTY GIVES YOU SPECIFIC RIGHTS, AND YOU MAY ALSO HAVE OTHER LEGAL RIGHTS WHICH MAY VARY FROM STATE TO STATE, OR PROVINCE TO PROVINCE.

Neither the distributor, any BOMBARDIER dealer nor any other person has been authorized to make any affirmation, representation or warranty regarding the product, other than those contained in this limited warranty, and if made, shall not be enforceable against BOMBARDIER.

BOMBARDIER reserves the right to modify this warranty at any time, being understood that such modification will not alter the warranty conditions applicable to the products sold while this warranty is in effect.

## **8. TRANSFER**

If the ownership of a product is transferred during the warranty coverage period, this warranty shall also be transferred and be valid for the remaining coverage period provided that BOMBARDIER is notified of such transfer of ownership in the following way:

- a) The former owner contacts BOMBARDIER (at the phone number provided below) or an authorized BOMBARDIER distributor/dealer and gives the coordinates of the new owner; or
- b) BOMBARDIER or an authorized BOMBARDIER distributor/dealer receives a proof that the former owner agreed to the transfer of ownership, in addition to the coordinates of the new owner.

## **9. CONSUMER ASSISTANCE**

- a) In the event of a controversy or a dispute in connection with this BOMBARDIER LIMITED WARRANTY, BOMBARDIER suggests that you try to resolve the issue at the distributorship/dealership level. We recommend discussing the issue with the authorized dealer's service manager or owner.
- b) If further assistance is required, the distributor's service department should be contacted in order to resolve the matter.

---

## FREQUENTLY ASKED QUESTIONS

- Q: Why must my vehicle be registered with the factory? After all, I do have my original invoice as proof of when I purchased my vehicle.
- A: *Registration is very important and an authorized Bombardier ATV dealer must register your vehicle with Bombardier Inc. Make sure the registration card has been sent. All of this will allow you to:*
- a) *Have warranty work performed at any authorized Bombardier ATV dealer in North America. Your registration card will provide the dealer with all the necessary data to complete warranty claim forms.*
  - b) *Be advised by Bombardier Inc. should there be a safety recall or a particular warranty campaign.*
  - c) *Be contacted much faster by the police, in the event that they find your vehicle subsequent to a theft.*
- Q: Why must my vehicle be registered with the governing body having jurisdiction over vehicle use?
- A: *Vehicle registration has two purposes: In many provinces or States, it is mandatory to register a vehicle in the same way as for a car. It allows the State or province to maintain records of existing vehicles. In some jurisdictions, governmental agencies use part of the registration fees for establishing and maintaining trails.*
- Q: Where can I find information on the lubrication and maintenance of my vehicle?
- A: *In the Operator's Guide provided with the vehicle at the time of delivery.*
- Q: Will the entire warranty be voided or cancelled, if I do not operate or maintain my new vehicle exactly as specified in the *Operator's Guide*?
- A: *The warranty of the new vehicle cannot be "Voided" or "Cancelled" if predelivered by an authorized Bombardier ATV dealer. However, if a particular failure is caused by operation or maintenance other than what is shown in the Operator's Guide, THAT failure may not be covered under warranty. This includes service work performed by the customer, oil and filter change and especially the critical adjustments such as the carburetor.*
- Q: Would you give some examples of abnormal use or strain, neglect or abuse which may affect the limited warranty coverage?
- A: *These terms are general and overlap each other in some cases. Some specific examples may include: running the engine out of oil, operating the vehicle with a broken or damaged part which causes another part to fail, and so on. If you have any specific questions on operation or maintenance, please contact an authorized Bombardier ATV dealer for advice.*
- Q: What costs are my responsibility during the warranty period?
- A: *The customer's responsibility includes all costs of normal maintenance services, non-warranty repairs, accidents and collision damage, as well as oils, and spark plugs, and incidental or consequential damages costs as explained in the warranty.*

Q: Are "Genuine" Bombardier replacement parts used in warranty repairs also covered by the limited warranty coverage?

A: *Yes. When installed by an authorized Bombardier ATV dealer, any "Genuine" Bombardier part used in warranty repairs assumes the remaining warranty that exists on the vehicle.*

Q: If I sell my vehicle within the warranty period, will the new owner qualify for the balance of the limited warranty coverage?

A: *Yes, provided the re-sale has been registered with the manufacturer.*

Q: How can I receive the best owner assistance?

A: *The satisfaction, safety and goodwill of the owners of Bombardier products are of primary concern to your ATV dealer and Bombardier Inc. Normally, any problems that arise in connection with the sales transaction or the operation of your vehicle will be handled by your Dealer's Sales or Service Departments. It is recognized, however, that despite the best intentions of everyone concerned, misunderstandings will sometimes occur. Frequently, complaints are the result of a breakdown in communications and can quickly be resolved by a member of the dealership management. If the problem already has been reviewed with the Sales Manager or Service Manager, contact the Dealer Principal himself or the General Manager.*

**We are always pleased to receive your comments on the Bombardier ATV.**

---

## **PRIVACY OBLIGATIONS/DISCLAIMER**

We wish to inform you that your coordinates will be used for safety and warranty purposes. Sometimes, we also use the coordinates of our clients to inform them about our products and to present them offers. Should you prefer not to receive information on our products, services and offers, please let us know by writing to the address below.

Also note that, from time to time, carefully selected and trustworthy organizations may be permitted to use the coordinates of our clients to promote quality products and services. If you prefer not to have your name and address released, please let us know by writing to the address below:

**Bombardier Inc.  
Recreational Products**

Warranty Department  
75 J.A. Bombardier Street  
Sherbrooke, Québec J1L 1W3  
Canada  
Fax Number (819) 566-3590









AFFIX  
PROPER  
POSTAGE

**BOMBARDIER**  
RECREATIONAL PRODUCTS

WARRANTY DEPARTMENT  
75, J.A. BOMBARDIER ST.  
SHERBROOKE (QUEBEC)  
CANADA J1L 1W3

**VEHICLE MODEL No.** \_\_\_\_\_

**VEHICLE IDENTIFICATION NUMBER (V.I.N.)** \_\_\_\_\_

**ENGINE IDENTIFICATION NUMBER (E.I.N.)** \_\_\_\_\_

**Owner:** \_\_\_\_\_

NAME

No.

STREET

APT

CITY

STATE/PROVINCE

ZIP/POSTAL CODE

**Purchase Date** \_\_\_\_\_  
YEAR MONTH DAY

**Warranty Expiry Date** \_\_\_\_\_  
YEAR MONTH DAY

To be completed by the dealer at the time of the sale.

DEALER IMPRINT AREA

**Please verify with your selling dealer to ensure your vehicle has been registered with Bombardier.**



**WARNING**

Indicates a potential hazard that, if not avoided, could result in serious injury or death.



 **WARNING**

**THIS VEHICLE CAN BE HAZARDOUS TO OPERATE.**

A collision or rollover can occur quickly, even during routine maneuvers such as turning and driving on hills or over obstacles, if you fail to take proper precautions.

**SEVERE INJURY OR DEATH** can result if

you do not follow these instructions:

- **BEFORE YOU OPERATE THIS VEHICLE, READ THIS OPERATOR'S GUIDE AND ALL ON-PRODUCTS LABELS.**
- **NEVER OPERATE THIS VEHICLE, WITHOUT PROPER INSTRUCTION.** New owners should complete a certified training course.
- **NEVER CARRY MORE THAN ONE PASSENGER.** You increase your risk of losing control if you carry more than one passenger.
- **NEVER OPERATE THIS VEHICLE ON ANY PAVED SURFACE** unless it is for short distances, at reduced speed and in order to move the vehicle from an off-road location to another.
- **ALWAYS RESPECT THE ROAD TRAFFIC LAWS** when you operate this vehicle on the roadway, even a dirt or gravel road.
- **OPERATOR AND PASSENGER SHOULD ALWAYS WEAR AN APPROVED HELMET,** eye protection, and protective clothing.
- **NEVER CONSUME ALCOHOL OR DRUGS** before or while operating this vehicle.
- **NEVER OPERATE THIS VEHICLE AT EXCESSIVE SPEEDS.** You increase your risk of losing control if you operate this vehicle at speeds too fast for the terrain, visibility conditions, or your experience. The maximum speed authorized with this vehicle is 65 Km/h.
- **NEVER ATTEMPT WHEELIES, JUMPS, OR OTHER STUNTS.**

