

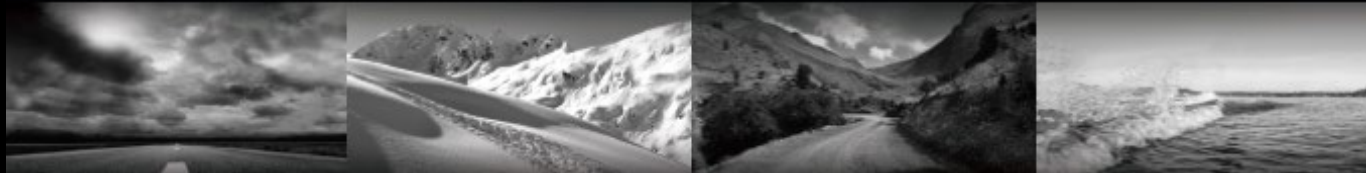

ski-doo *LYNX* *SEA-DOO* *ROTAX* *can-am*



OXYGEN FLOW HELMET

USER GUIDE

USER GUIDE

OXYGEN FLOW

ENGLISH



OXYGEN FLOW Ski-Doo® Helmet

CONGRATULATIONS!

You have made an excellent choice with the BRP Ski-Doo® OXYGEN FLOW helmet.

The OXYGEN FLOW helmet is the result of the very latest design and manufacturing methods. This helmet combines the top characteristics of a sport helmet with the comfort of a touring helmet.

You can feel secure in the knowledge that you now own a quality helmet that is designed to provide you safety and high standards of performance – in particular on long journeys – and that will give you a great deal of pleasure at the same time.

Please take the time to read through this manual carefully so that your helmet protects you properly when riding your snowmobile or motorcycle. To ensure that you do not overlook any aspect of the manual that is relevant to your safety, we recommend that you read it in the order in which it appears.

WARNING

This helmet is not intended for use in Europe where ECE Standard is the only approved standard. This helmet was not designed to be used by a child under 13. The helmet has been inspected and approved according to the DOT Standard and therefore, does not conform to specific European countries regulations and requirements. It is only legal to use the helmet in countries in which the DOT Standard is valid. If you use the helmet in other countries, you will not, in the event of injury, be entitled to make a claim for compensation before the courts of these countries, not bound by the DOT Standard.

We wish you a safe ride.



CONTENTS

A. GENERAL	4
1. SAFETY INFORMATION	4
B. THE HELMET	5
1. ANATOMY OF THE HELMET	5
2. HELMET SIZING	5
3. AEROACOUSTICS	5
4. PROTECTIVE COLLAR	6
5. MICROMETRIC CHIN STRAP	7
6. FACE SHIELD	8
7. SUN VISOR	9
8. MAGNETIC CONNECTOR	10
9. REAR LIGHT	11
10. FACE SHIELD MECHANISM	12
11. NOISE CONTROL SYSTEM	13
12. INNER LINER	13
13. VENTILATION SYSTEM	15
14. BREATH GUARD	15
15. REMOTE CONTROL	16
C. FIT & USAGE	17
1. HOW TO PUT THE HELMET ON	17
2. PROPER FIT	17
3. PUT THE HELMET OFF	18
4. OPERATING INSTRUCTIONS	18
5. COMMUNICATION SYSTEM	20
D. BEFORE EVERY RIDE	22
1. CHECKING THE HELMET	22
2. CHECKING THE CHINSTRAP	22
3. CHECKING THE FACE SHIELD AND SUN VISOR	23
4. CHECKING THE MAGNETIC CONNECTOR	23

E. OTHER IMPORTANT INFORMATION.....	23
1. MODIFICATIONS / ACCESSORIES	23
2. FROSTBITE	24
F. CARE AND MAINTENANCE	25
1. SHELL CLEANING	25
2. INTERIOR CLEANING	25
3. OUTER SURFACE OF THE FACE SHIELD	25
4. HEATING LENS	25
5. ELECTRICAL CONNECTIONS	25
6. SUN VISOR	26
7. HELMET INSPECTION	26
8. HELMET STORAGE	26
G. TROUBLESHOOTING GUIDE	27
H. ACCESSORIES AND SPARE PARTS	28
1. ACCESSORIES	29
2. REPLACEMENT PARTS	29
3. LED UTILITY LIGHT INSTALLATION	29
4. LED UTILITY LIGHT BATTERIES REMPLACEMENT	30
I. BRP SERVICE.....	31
1. REPAIR SERVICE	31
2. WARRANTY	31
J. HOW TO CONTACT US.....	32

A. GENERAL

1. SAFETY INFORMATION

This helmet is backed by the BRP warranty and a network of authorized dealers ready to provide the parts, service or accessories that you may require. Genuine BRP parts should be used for replacement to maintain the warranty, consult an authorized BRP dealer.

Use this User Guide to acquaint yourself with your new helmet and its various functions. Make sure you read and understand the contents of this guide and keep it for future reference. The information and components descriptions contained in this guide are accurate at time of publication. The illustrations in this document may not show the typical construction of the different assemblies or may not reproduce the full detail or exact shape of the parts shown, however, they represent parts which have the same or a similar function.

This guide uses the following safety alert symbol in conjunction with signal words to indicate a potential personal injury hazard.

WARNING

Indicates a hazardous situation which, if not avoided, could result in death or serious injury.

NOTICE

Address practices not related to personal injury.

Simply reading this guide will not eliminate hazards. The user must understand and follow the instructions. Because of its ongoing commitment to product quality and innovation, BRP reserves the right at any time to discontinue or change specifications, designs, features or equipment without incurring obligation. If anyone seeks to translate any portion of this guide into any language, he must ensure that the translation is accurate.

WARNING

Riding a motorized vehicle can be dangerous. This helmet provides limited protection to the head. It complies with U.S. Federal Motor Vehicle Safety Standard 218.

However, it will not protect the wearer against all possible impacts. Some impacts may exceed this helmet's capability to provide protection and result in serious head, brain, spinal, or other injury including paralysis or death.

For maximum protection, the helmet must fit firmly on the head with the chin strap securely fastened.

If your helmet is equipped with a main visor, it must be fully closed. If your helmet is equipped with other component, such as wind deflector, breath deflector, breathing mask, mandible, etc., make sure to install them in proper position to direct exhaled breath away from the main visor.

Always wear appropriate protection against frostbite, which may include a balaclava, neck tube, facemask or combination of these items.

Inspect the helmet before each use following the inspection procedure in the instructions. Replace any part showing wear or damage. Do not alter the helmet or attach any items not recommended by the manufacturer. The helmet is designed to absorb shock by partial destruction of the shell and it should not be visible. Destroy and replace helmet if subjected liner, which may not be visible. Destroy and replace helmet if subjected to a severe blow even if it appears undamaged.

The helmet shell, liner and other components may be damaged and rendered ineffective by petroleum products, cleaning agents, paint, adhesives, etc., without the damage being visible. Use only warm mild soapy water to clean the helmet.

Follow all warnings and instructions provided with this helmet. For replacement instructions, contact BRP. Failure to follow all warnings and instructions can result in serious personal injury or death.

B. THE HELMET

1. ANATOMY OF THE HELMET

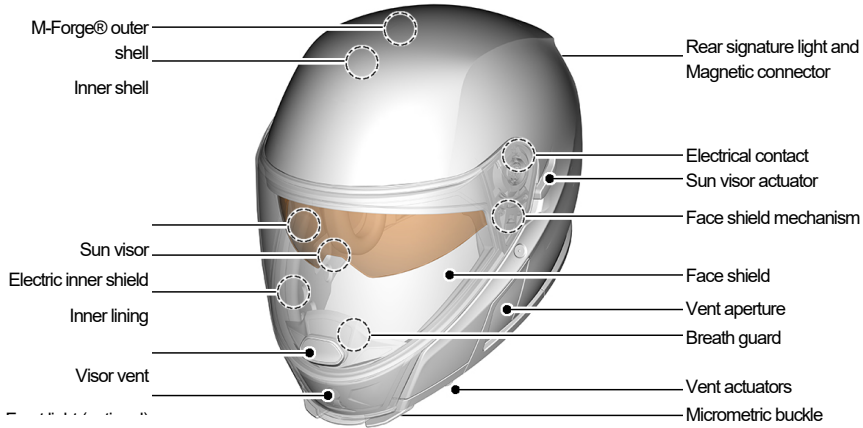

2. HELMET SIZING

Helmet size		S	M	L	XL	2XL	3XL
Shell size		L			2XL		
Head size	mm	55 - 56	57 - 58	59 - 60	61 - 62	63 - 64	65 - 66
	Inches	21 5/8 - 22	22 3/8 - 22 3/4	23 1/8 - 23 5/8	24 - 24 3/8	24 3/4 - 25 1/8	25 1/2 - 25 7/8

3. AEROACOUSTICS

Various features developed by BRP make the helmet agreeably quiet as far as aeroacoustics are concerned, while providing optimized acoustic feedback when riding.

Aeroacoustics values may vary according to the type of snowmobile, fairing design, windshield size, seat position and physical size of the rider.

⚠ WARNING

Because of the aeroacoustics optimization of the helmet (and the lower wind noise inside the helmet that comes with it), your actual speed can be underestimated. Please do not rely on your sense of hearing to estimate your speed or to estimate the distance with other vehicles – always check it using your speedometer and the surroundings.

B. THE HELMET

4. PROTECTIVE COLLAR

The protective collar reduces air intrusion and unpleasant effect of the wind created when you ride by flowing into the helmet. This feature allows to also reduce the riding noises (such as wind, motor, track...).

The fit at the bottom of the helmet is extremely important to make the helmet as quiet as possible. Even with the protective collar, we recommend you wear a balaclava.

REMOVING THE PROTECTIVE COLLAR

1. Take one side of the protective collar and pull it out of its fitting (in red).

2. To release the neck pad, pull gently upward to disengage the plastic strip.

3. Then, pull the 2nd notch out of its fitting on the other side.

4. The protective collar is also attached on the chin portion by 4 “arrow snaps”. To fully remove the protective collar, pull gently on the chin portion, toward the center of the helmet.

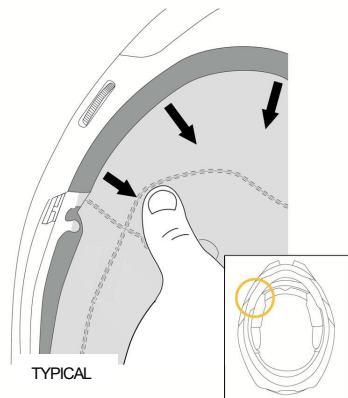
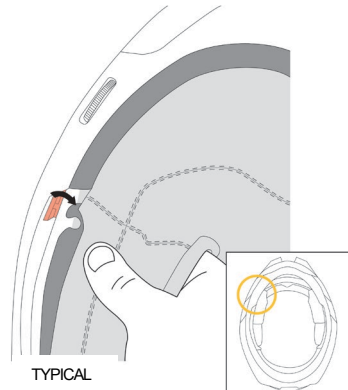

INSTALLING THE PROTECTIVE COLLAR

1. Insert the 4 “arrow snaps” on the chin plastic strip inside their specific housing.

2. Once the chin plastic strip is in position. Insert one of the notches located on each side of the neck pad plastic strip into the red housing as shown on the picture.

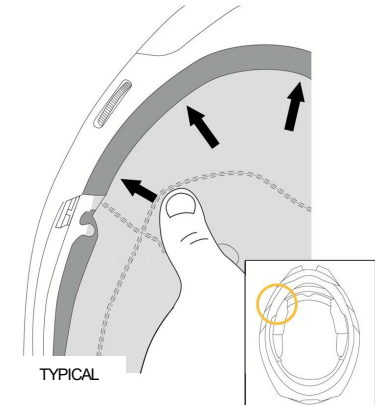

3. Then, insert the plastic strip between the impact absorbing liner and the shell, from the one side to the other, by pushing it inside and backward at the same time to be able to match the other notch with the other red housing.

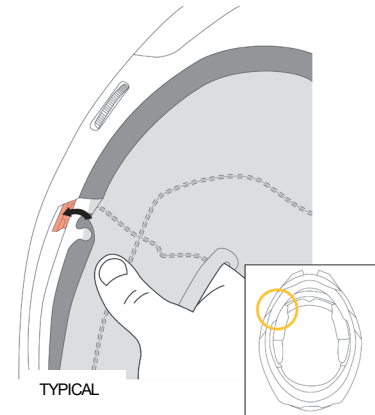

4. Once it is done and the neck pad plastic strip is in position, insert the second notch into its red housing.

⚠ WARNING

Do not carry or hold the helmet by the protective collar. The protective collar may come off, causing the helmet to drop.

B. THE HELMET

5. MICROMETRIC CHIN STRAP

The retention system of the OXYGEN helmet comes with a ratchet fastener. This locking system is easy to use and enables you to adjust the chinstrap perfectly to your head every time you put the helmet on.

ADJUSTING THE CHIN STRAP

The length of the chinstrap is adjusted by increasing or reducing the length of strap pulled through the metal buckles. Adjust the length of the chinstrap so that it fits firmly but comfortably under your chin and fix the end of the strap using the retaining loop with comfort pad.

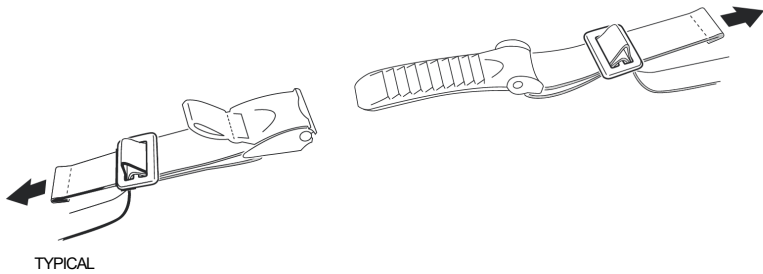

⚠️ WARNING

When adjusting the strap, make sure that the helmet cannot be pulled off in a forward direction with the chinstrap closed.

⚠️ WARNING

Check the adjustment of the chinstrap length at regular intervals.

OPENING AND CLOSING

To close the chinstrap fastener, slide the ratchet tongue step by step into the locking buckle. If you find that the chinstrap fits too loosely around your chin, slide the ratchet tongue one step further into the locking buckle.

When adjusting the chinstrap, make sure that it rests firmly but not uncomfortably around your chin. To open the chinstrap, pull the red ribbon on the ratchet fastener upwards to release the locking buckle. Then pull the ratchet tongue out of the locking buckle.

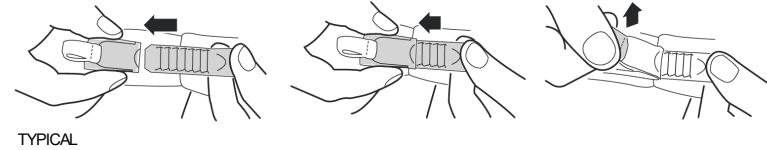

⚠️ WARNING

Never ride without making sure that the chinstrap is correctly fastened and adjusted and properly positioned. If the chinstrap is not correctly adjusted or fastened, the helmet could be displaced in the event of an accident.

⚠️ WARNING

Closing the comfort pad of the chinstrap alone will not provide adequate protection. The chinstrap must always be fully fastened.

⚠️ WARNING

Never open the chinstrap while riding.

B. THE HELMET

6. FACE SHIELD

Changing the visor shield is easy to do without tools. To replace the visor, it is helpful to place the helmet on a flat surface or on your lap while seated.

REMOVING THE FACE SHIELD

1. Move the face shield into the uppermost locked position.

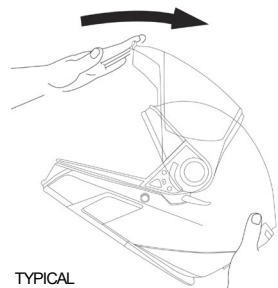

2. On one side, pull the lever of the face shield mechanism downward to release the lower tab of the face shield.

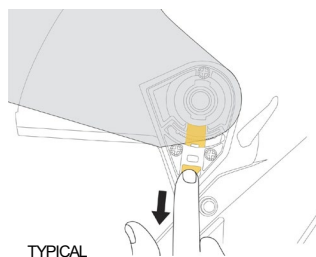

3. Move the lower portion of the face shield pivots upwards until the lower tab is released from the face shield mechanism.

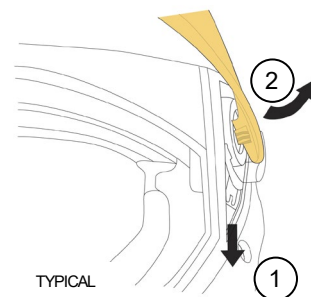

4. Then, pull the face shield downward to release the upper tab from the face shield mechanism.

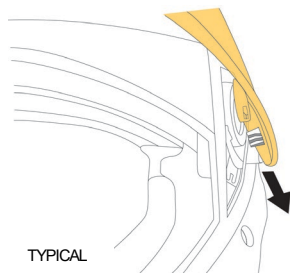

5. Repeat steps 1 – 4 for the other side.

INSTALLING THE FACE SHIELD

1. Insert the upper tab of the face shield into the specific location on the face shield mechanism.

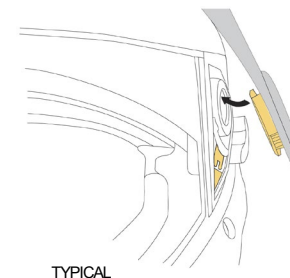

2. Once the tab is in position, pull the lever of the face shield mechanism downward and slightly push the lower portion of the face shield to put back in position the lower tab of the face shield.

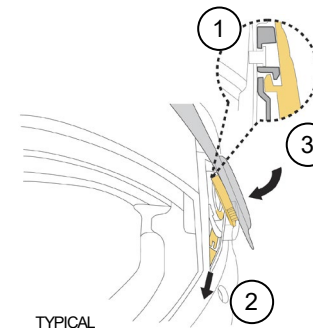

3. Then, release the lever. Make sure the spring put it back to the up position and check if the visor is correctly in place.

4. Repeat steps 1 - 3 for the other side.

For the other side, note that the face shield will be slightly tilted. Make sure the lower tab of the face shield and the recess are perfectly aligned.

B. THE HELMET

5. Once both sides are in position, press the face shield pivots gently towards the helmet with a simultaneous closing movement.

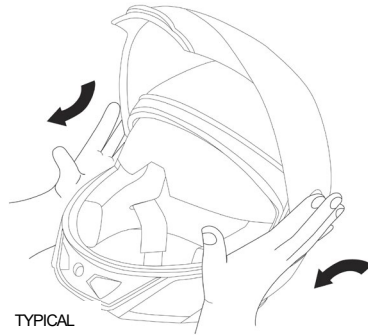

6. Make sure that the face shield mechanism is functioning properly by closing and opening the face shield to its maximum extent.

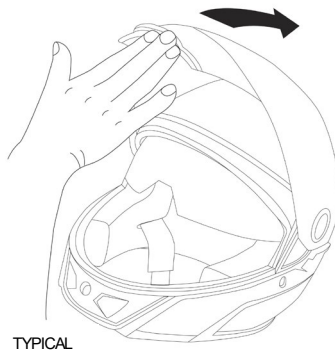

7. SUN VISOR

OPERATION

The sun visor is operated by the lever positioned on the left side of the helmet, which makes it easy to use even when wearing thick gloves.

Moving the lever upward lowers the sun visor, moving it downward retracts the sun visor inside the inner helmet shell and locks it in position.

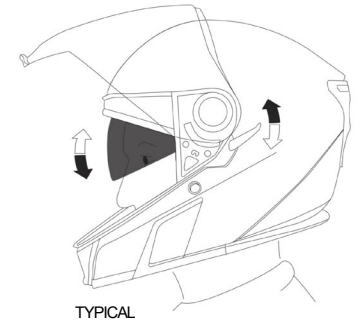

If during your ride you experience fogging or frosting on your sun visor, simply raise it back to the up position, wait a minute, and then drop it back down. The sun visor's upper storage position is heated, that will disperse any fogging that may have occurred.

REMOVING THE SUN VISOR

1. Pivot the sun visor in the lower position.
2. Pull the sun visor downward until you see the upper edge.
3. Hold your helmet in position and pull the sun visor on the right side, toward the outside of the helmet.
4. Repeat steps 2-3 for the other side.

The sun visor lever should remain in the same position while you install the visor.

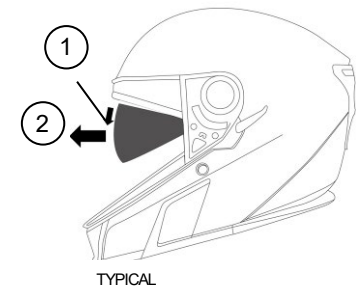
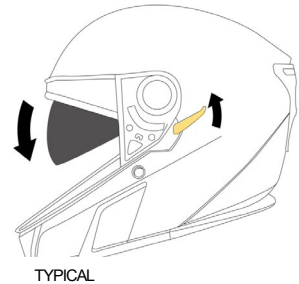

B. THE HELMET

INSTALLING THE SUN VISOR

1. Make sure the sun visor mechanism is in low position. (Sun visor lever up)

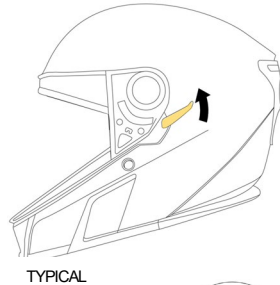

2. Insert the sun visor between helmet inner and outer shell and fit it on to the locating pegs on both sides.

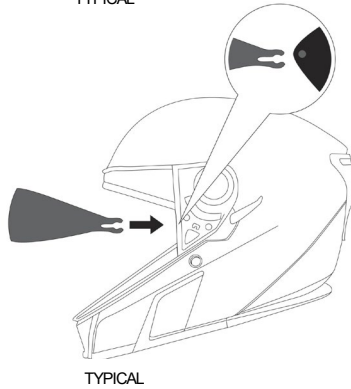

Then, press firmly towards the inside of the helmet until the fork's inner insert is completely inserted.

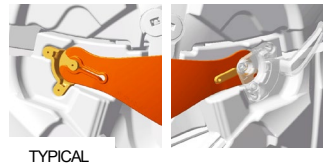

3. Check that the sun visor mechanism is functioning correctly.

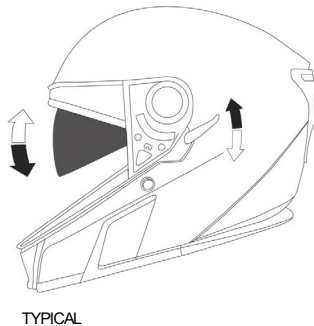

8. MAGNETIC CONNECTOR

1. Make sure your magnetic connector and your helmet power outlet are clean.

2. Plug the eLinQ connector directly into the power outlet of your OXYGEN FLOW helmet.

The power outlet and eLinQ connector might become warm during normal use.

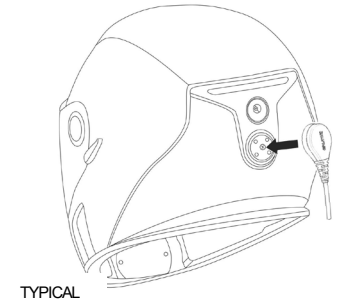

NOTICE

Do not pull directly on the cord to remove the eLinQ connector from your helmet.

B. THE HELMET

9. REAR LIGHT

OPERATION

This helmet is equipped with a rear light which increase your visibility. The rear light turns ON as soon as you are connected to your vehicle and your engine is running. There is no switch to turn this light OFF.

REMOVING / REPLACING THE REAR LIGHT

1. Remove the BRP logo sticker just below the rear light.

2. Use a Phillips #1 screwdriver to remove the two screws (1) and (2).

3. Grab the rear light module by the bottom and lift it gently.

NOTICE
If the wires are stuck into the shell, do not force on the rear light module, you could damage it. Gently pull the wires out of the shell.

4. Once you can see the wires, pull the rear light module downward while lifting the bottom until you clear the two hooks at the top of the rear light module.

5. Then disconnect the two connectors by grabbing them and pulling on the opposite direction.

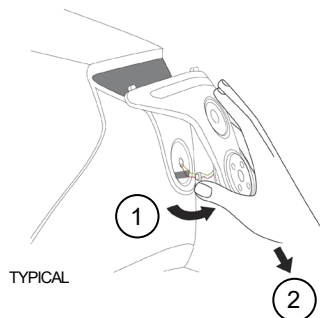
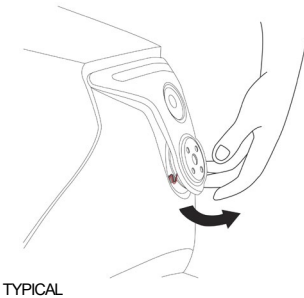
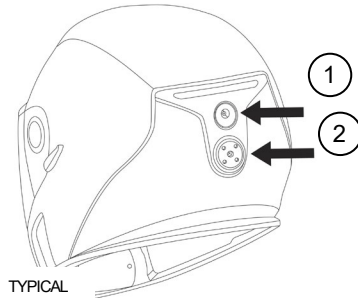

NOTICE

Do not pull directly on the electrical wires, you could damage them.

6. Take a new rear light and connect the electrical connector.

7. Once the two connectors are plugged, put gently the wires into the helmet.

8. Insert the two hooks onto the shell, as shown.

9. Push back the rear light module and, at the same time, make sure that you put the wires back into the helmet.

10. Once the rear light module is in position, secure it in position by tightening the 2 screws (0.3 Nm).

NOTICE
Do not over-torque the screws, you could damage them.

11. Put the new BRP logo over the upper screw.

Make sure that the surface is clean; otherwise the adhesive will not stick.

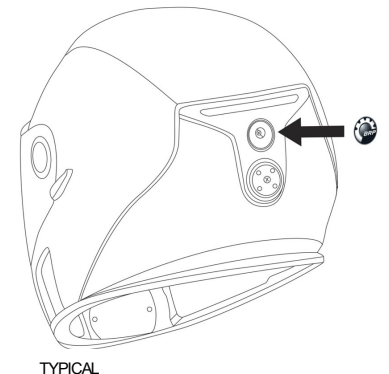
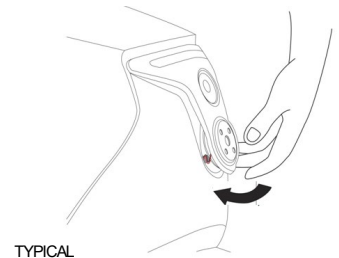
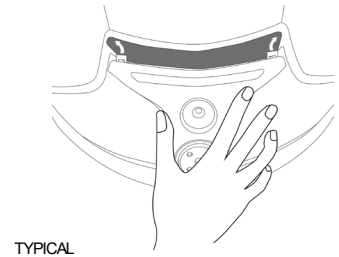

B. THE HELMET

10. FACE SHIELD MECHANISM

REMOVING / REPLACING THE FACE SHIELD MECHANISM

1. Remove the face shield as described in the “6. FACE SHIELD” section of this manual.

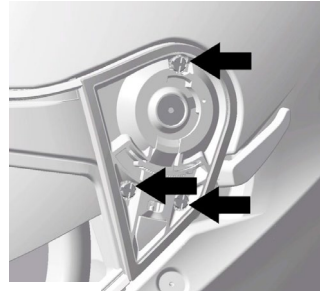

TYPICAL

2. Use a Phillips #1 screwdriver to remove the three screws (1), (2) and (3).

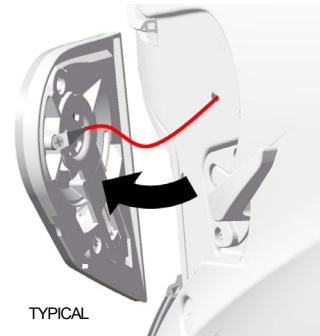

TYPICAL

3. Grab the mechanism and lift it gently.

NOTICE

If the wires are stuck into the shell, do not pull the mechanism, you could damage them. Grab the wires and try to pull them gently out of the shell.

4. Once you have access to the screw, use a Phillips #00 screwdriver to disconnect the mechanism from the helmet circuit.

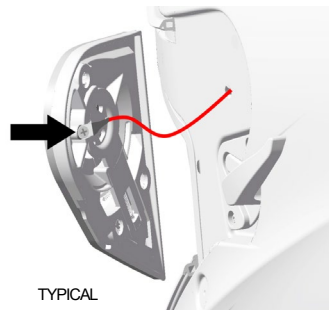

TYPICAL

NOTICE

Do not pull directly on the electrical wires, you could damage them.

5. Take a new mechanism and connect the electrical wire as shown, by tightening the screw to 0.3 Nm.

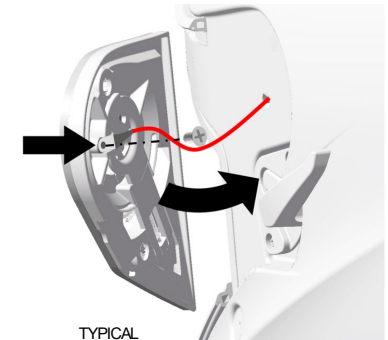

TYPICAL

Make sure there is no free play in the connection once the screw is fully tightened.

6. Put back gently the wire into the helmet. Once the wire is almost entirely inside the helmet, position the mechanism and put back the three screws. Tighten them to 0.4 Nm.

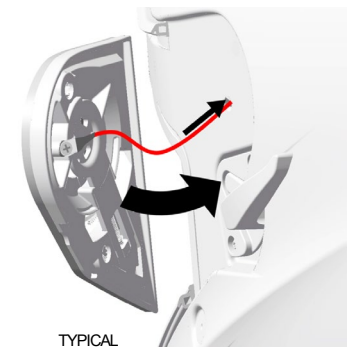

TYPICAL

NOTICE

Do not pinch the wire between the mechanism and the shell.
Do not overtighten the screws, you could damage them.

7. Repeat steps 2 – 6 for the other side.

8. Put back the face shield as described in the “6. FACE SHIELD” section of this manual.

9. Connect your helmet to your vehicle for a quick functional test, to make sure everything is working properly.

B. THE HELMET

11. NOISE CONTROL SYSTEM

Your helmet is equipped with noise reduction ear pads. You can adjust the pads position to achieve the desired comfort by following the steps below:

- Place the helmet upside down in front of you so that the visor is pointing downwards;
- Verify that the pads are correctly held in place by the Velcro;
- Put on your helmet as described in the “2. PROPER FIT” section of this manual;
- Determine your ideal pad position;
- Take off and flip your helmet, and adjust the pads as per previously determined position.
- If needed, you can also add the provided foams (3 mm thick) behind the pads to adjust the thickness and get a better fit.
- Repeat as needed until desired comfort is reached.

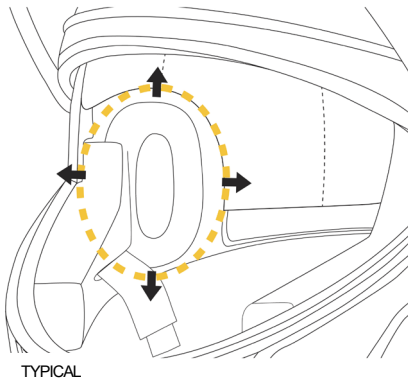

If your head measurements match the size of the helmet you are trying, but it feels too snug on the sides of your head, you can completely remove the noise control system from the helmet.

It will not affect the helmet performances as far as the fit is correct except the noise reduction.

⚠ WARNING

Always be alert for sounds – Your helmet may impair your hearing.
Your helmet is not a form of hearing protection.

12. INNER LINER

The replaceable inner lining of the OXYGEN helmet is washable and ensures both an excellent fit and improved ventilation of the helmet. The dual-density cheek pads have a specific 3D shape to ensure that the helmet fits comfortably around the cheeks, and the headliner provides an optimal fit all around the head.

All interior fittings are made entirely of skin-friendly material. The material used for the cheek pads and head liner has been treated with Silverplus®.

When removing the lining, the cheek pads must first be detached before taking out the headband pad. When fitting the lining, remember to insert the headband pad before the cheek pads.

PAD SIZES

Helmet size	S	M	L	XL	2XL	3XL	
Cheek pad thickness	55 mm	44 mm	38 mm	38 mm	38 mm	32 mm	
Head liner thickness	Top	12 mm	12 mm	12 mm	12 mm	8 mm	8 mm
	Crown	20 mm	16 mm	12 mm	12 mm	12 mm	8 mm

B. THE HELMET

REMOVING THE CHEEK PADS

1. First remove the protective collar.
(See instruction page 6)
2. Unfasten the 3 snaps to remove the first part of the pad. Next, pull the upper part of the cheek pad, to detach the Velcro.
3. Repeat these steps for the other side

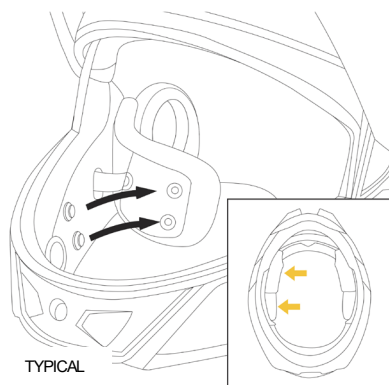

INSTALLING THE CHEEK PADS

1. Before installing the cheek pads, identify the right and the left sides.
2. Fasten the 3 snaps and attach the Velcro upper part in position. Make sure the strap is in position inside the cheek pad notch.
3. Repeat these steps for the other side

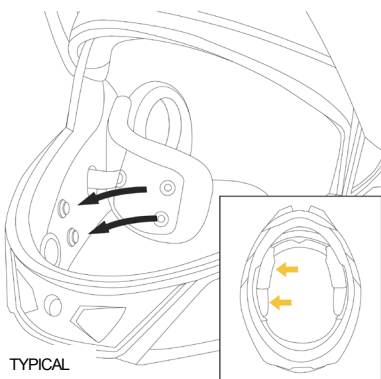

REMOVING THE HEAD LINER

1. First, remove the protective collar.
(See instruction page 6)
2. Second, remove the cheek pads.
3. The head liner is attached to the inner shell with 2 snaps (on each side of the neck) and a frontal portion, with 3 snaps. They can be removed by pulling them out carefully.
For the frontal portion, start to pull from one side of the plastic strip.

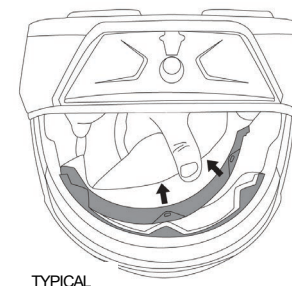
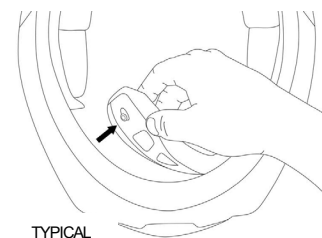

INSTALLING THE HEAD LINER

1. Insert the frontal plastic strip under the notches of the other plastic strip attached to the inner shell.
2. Next, position the head liner inside the helmet.
3. Then, fasten the 2 snaps on the neck portion.

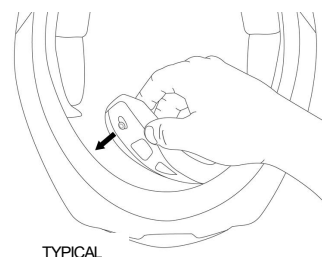
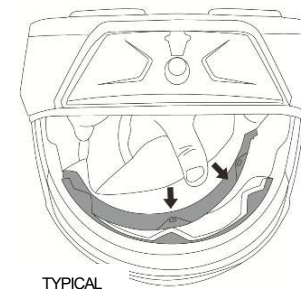

⚠ WARNING

Never ride when parts of the inner lining have been removed.

To avoid damage to the inner lining and inner shell, do not hang the helmet over the mirrors or handlebar grips.

B. THE HELMET

13. VENTILATION SYSTEM

The OXYGEN FLOW helmet has a two-way adjustable ventilation system. As needed, you can modulate the air flow as per two configurations for the air intake and several distinct configurations for the air exhaust:

The air intake can be modulated by adjusting the visor vent.

1. OPEN: When placing the visor vent into the lower position, air will flow freely into the helmet

2. CLOSED: When placing the visor vent into the upper position, air will not flow into the helmet.

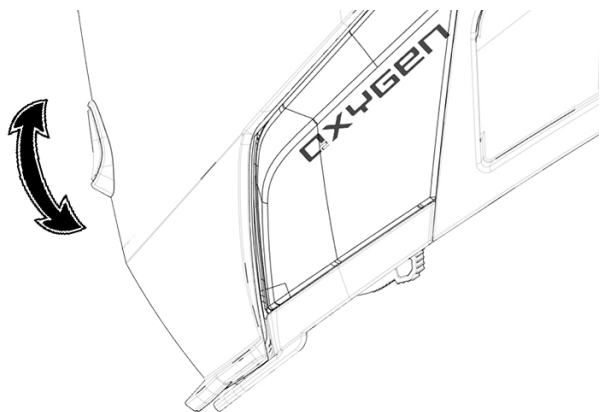

The air exhausted from the helmet can be adjusted using the side lower vent.

1. OPEN: When placing both sliding buttons on the «≡» position, this indicates that the air circulates freely;

2. CLOSED: When placing both sliding buttons on the «☒» position, this indicates that the air does not circulate;

3. OPEN/CLOSED: When placing one of the sliding buttons (left or right) on the «≡» position and the other one on the «☒» position, this indicates that the air circulates freely on one side only.

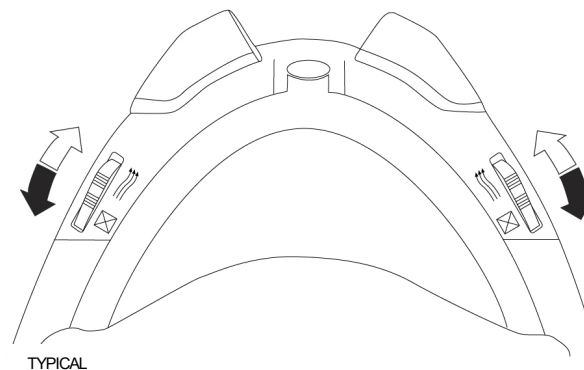

In all cases, it allows you to increase or reduce the air flow to reach the desired level of comfort.

Note that the snowmobile speed, the windshield or the head rotation can affect the air flow inside the helmet.

14. BREATH GUARD

The breath guard reduces fogging of the visor caused by breathing.

REMOVING THE BREATH GUARD

Grab and pull the breath guard from the sides first, then, detach the Velcro portion in the middle.

B. THE HELMET

INSTALLING THE BREATH GUARD

As shown below, firmly insert the breath guard between the cheek parts of the impact absorbing liner and the trim. Begin by the four legs, and finish by the Velcro part.

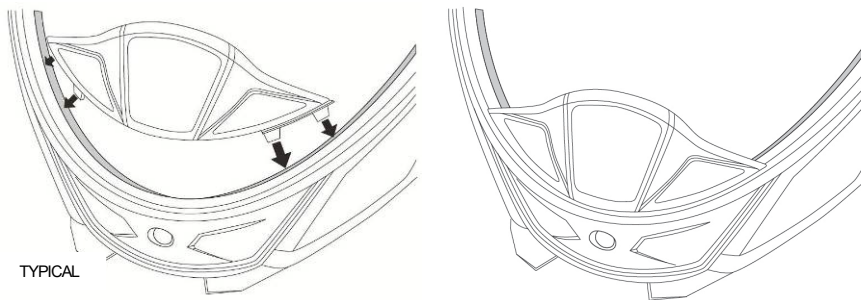

⚠ WARNING

Do not carry or hold the helmet by the breath guard. The breath guard may come off, causing the helmet to drop.

15. REMOTE CONTROL

The OXYGEN FLOW helmet has been designed to perform at very cold temperatures, but to keep the performances without compromising the comfort, you can adjust the heat intensity to the weather conditions.

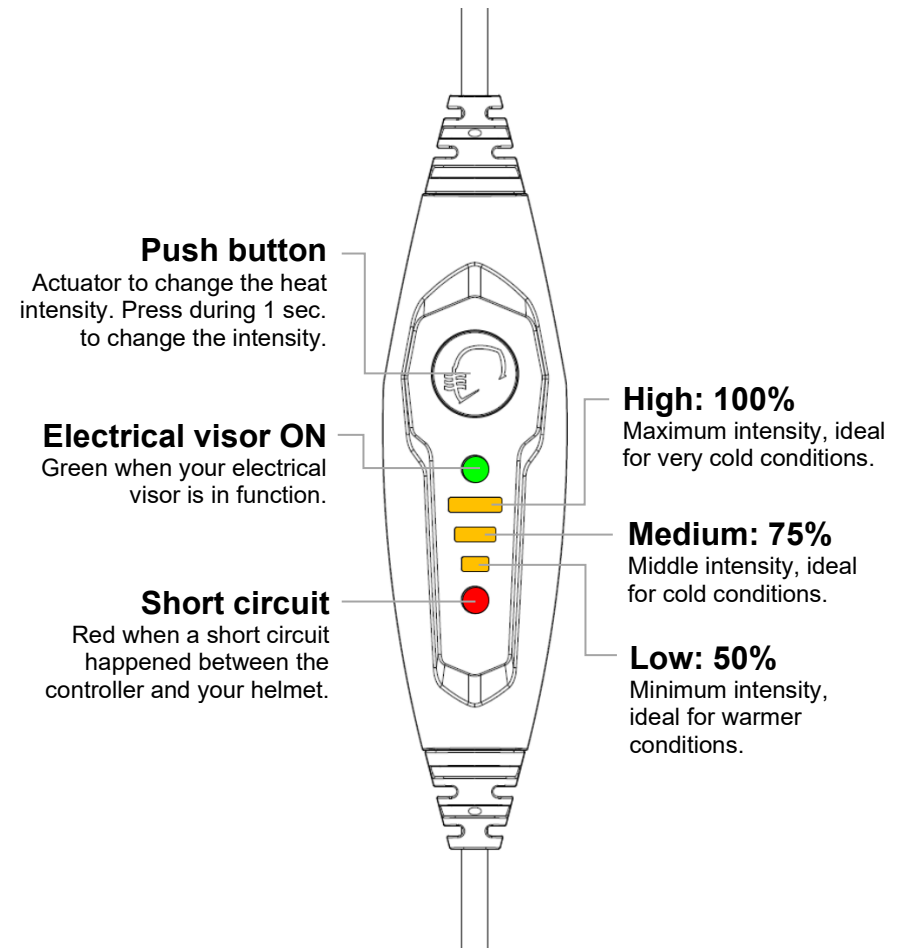

If the red LED is lighted, this means that a short circuit happened, follow the steps below:

1. Stop your vehicle.
2. Unplug your device from your vehicle.
3. Look for the root cause of the short circuit.

See the Troubleshooting section of this manual.

C. FIT & USAGE

1. HOW TO PUT THE HELMET ON

1. Make sure the sun visor is retracted into the helmet shell.
2. Move the neck protector outward to clear the opening.
3. Open the chinstrap and chinstrap comfort pad.
4. Pull apart the lower ends of the chinstrap.
5. It will now be easy to put the helmet on.
6. Make sure your ears are inside the earmuffs.
7. Close and fasten the chinstrap.
8. Make sure the chinstrap passes under the chin and fits snugly.
9. Check that the chin section is securely locked by pressing it up from below.

2. PROPER FIT

WARNING

Wearing the wrong helmet size can increase the risk of serious injury or death in an accident. A helmet that is too large for your head may be dislodged or knocked off in an accident.

To select the right helmet size for your head, follow the steps:

1. TRY ON THE HELMET

Grasp both chin straps to pull the helmet completely onto your head, ensuring that the top of your head is in contact with the top of the helmet interior. Try the helmet with all the protection you plan to use (balaclava, neck tube, face mask, etc.)

2. CHECK FOR A PROPER FIT

To make sure that your helmet is the right size, check that:

- The helmet inner lining fits snugly around your head.
- The top pad presses firmly on your head.
- The cheek pads contact your cheeks.
- There is no space around your brow under the inner lining. Test this by trying to insert your fingers. If the helmet does not fit snugly, try on a smaller size.
- Adjust the earmuffs position to fit on your head, around your ears, not on your ears.

This step might take several trials before finding the perfect adjustment.

C. FIT & USAGE

3. CHECK YOUR FIELD OF VISION

Some helmets may obstruct or block your vision when looking left, right, up, or down.

WARNING

Always make sure you can see well enough to safely operate your vehicle.

4. TEST THE HELMET FIT

Place your hands on each side of the helmet. While holding your head as motionless as possible, try rotating your helmet from left to right then up and down. You should feel the helmet move the skin on your head and face as you try to move the helmet.

If it is not the case or if you can feel the helmet padding sliding on your head, it is too big. If the helmet is constricting or painful, it is too small.



TYPICAL

5. FASTEN THE CHIN STRAP

Tight it under your jaw until it remains no slack in the strap, and the strap must be tight up against your jaw.

6. TEST THE CHIN STRAP FIT

- Put your hands on the back of the helmet (B) and try to push the helmet off by rotating it forward.
- Put your hands on the front of the helmet above your forehead (or on the chin guard) and try to push.
- If helmet comes off, try another size or model.

Repeat steps 1 through 6 until you find a helmet that fits your head snugly and securely.

3. PUT THE HELMET OFF

1. Make sure the sun visor is retracted into the helmet.
2. Open the chinstrap.
3. The helmet can now be removed easily from the head.

To avoid scratching any objects you might place the helmet on, we recommend closing the chin-strap after you have taken the helmet off.

4. OPERATING INSTRUCTIONS

CONNECTING THE POWER CABLES

We highly recommend that you get your helmet cables connected by an authorized BRP dealer so that he can refer to the vehicle's shop manual to determine the best connection point.

C. FIT & USAGE

1. Vehicle Connection

- Option 1a: Via the vehicle's power outlet intended for this purpose (sold separately).

For more details, see your authorized BRP dealer.

- Option 1b: Via the battery power outlet intended for this purpose (sold separately).

For more details, see your authorized BRP dealer.

⚠ WARNING

It is important not to connect the helmet to another electrical accessory (like heated grips) to avoid overloading existing circuits. This could lead to a fire.

2. Power cable (vehicle side)

- Connect the vehicle power cable to the main power outlet (1a or 1b) and leave it in position for further use.

3. Magnetic power cable

- Then, place your riding coat on a clean surface and route the magnetic connection cable as shown below:

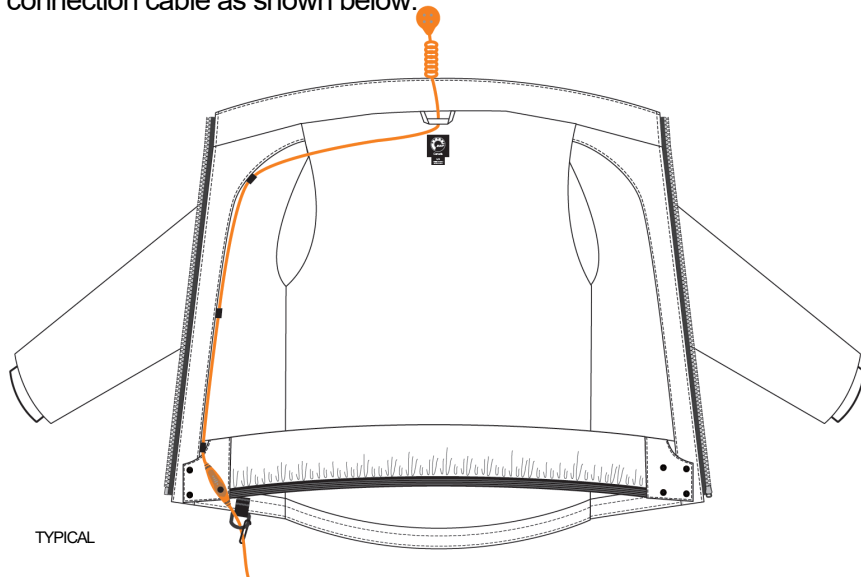

4. Final connection

- Once the magnetic connection cable is in place, put on your coat and let the power cable pass under your left or right arm, depending which side is your key ring on your coat;

- Put on your helmet as described in the “2. PROPER FIT” section of this manual;

- Grab the magnetic connector at the back of your neck and bring it closer to the connection housing at the back of the helmet. The magnets will automatically find and position themselves.

- Next, grab the RCA end of the magnetic connection cable and connect it to the vehicle power cable.

⚠ WARNING

Ensure that the cables stay away from any moving parts. Do not let the power cables become entangled in the vehicle and do not drive over them. Only use BRP approved extension cord. If the cables are damaged, stop using them. Discard and replace them with new OEM BRP cables.

⚠ WARNING

The magnets contained in this helmet could interfere with the operation of electronic devices such as pacemakers. Please consult your doctor before wearing this product.

Also, note that the credit cards' magnetic stripe could be affected.

C. FIT & USAGE

5. COMMUNICATION SYSTEM

OPTION A: SPEAKERS WITH NCS

A.1. Remove the NCS from the helmet (held by Velcro™).



A.2. Remove the foam cut out from each NCS by ripping the center circle portion.



A.3. Remove the white foam inside the NCS.



A.4. Disconnect the speaker from the main module by pulling on both ends of the connector.

A.5. Pass the speaker connection into the hole in the back of the NCS so that it points to the back of the helmet.



A.6. Using the Velcro™, position and fix the speaker inside the NCS.



A.7. Reinstall the NCS into the helmet, making sure the openings are at the base of the helmet and the speaker cable is pointing toward the back of the helmet.



A.8. Reconnect the speaker cable with the BLACK female connector from the main unit. Repeat on the other side.

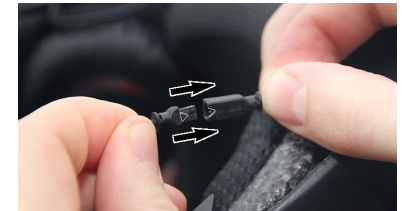

C. FIT & USAGE

OPTION B: SPEAKERS WITHOUT NCS

B.1. Remove the NCS from the helmet (held by Velcro™).



B.2. If no configuration with the NCS feels comfortable, the NCS can be removed from the helmet and replaced with the speaker.



B.3. Make sure the speaker wire is pointing toward the back of the helmet.

B.4. Adjust the speakers position in the helmet to maximize comfort and sound quality. Repeat on the other side.

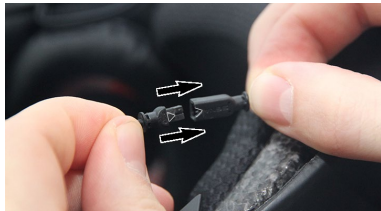

B.5. Reconnect the speaker cable with the BLACK female connector from the main unit. Repeat on the other side.

CABLE MANAGEMENT

1. For the right speaker, place the excess wire behind the headliner near the neck.

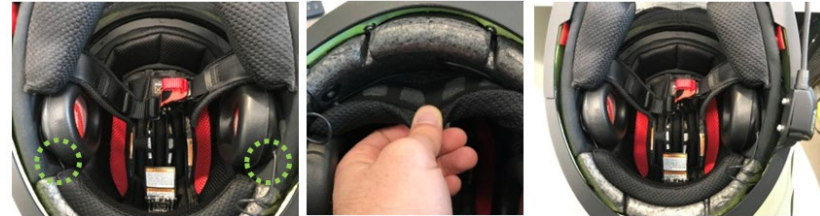

C. FIT & USAGE

MICROPHONE INSTALLATION

1. For **boom microphone** communication systems, install the jog dial behind the side trim fastener (as shown above).

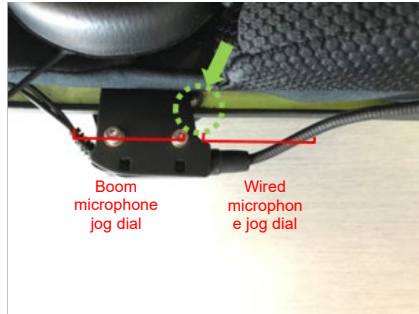

2. For **wired microphone** communication systems, install the jog dial in front of the side trim fastener (as shown above).

3. Position the boom microphone as shown and then, reinstall the protective collar.



D. BEFORE EVERY RIDE

1. CHECKING THE HELMET

Regularly inspect your helmet for damage. Small superficial scratches will not impair the protective function of your helmet.

⚠ WARNING

In the case of more serious damage (cracks, dents, flaking and cracking paint, etc.), the helmet should no longer be used.

2. CHECKING THE CHINSTRAP

1. Check that the chinstrap passes under your chin.

2. Slip your index finger under the chinstrap and pull.

If the chinstrap is loose under the chin, it is too long and needs to be tightened.

If the chinstrap loosens when you pull it, it is not properly fastened.

Undo the chinstrap completely and try fastening it again. Repeat the test.

3. If you are unable to fasten the chinstrap so that it fits firmly against the chin, check that your helmet is still the right size for you.

Repeat the test after each adjustment.

⚠ WARNING

Never ride with the chinstrap unfastened or incorrectly adjusted. The chinstrap should fit correctly and should not become loose when pulled. The fastener is not correctly closed if the chinstrap becomes loose when pulled.

D. BEFORE EVERY RIDE

3. CHECKING THE FACE SHIELD AND SUN VISOR

The protective film used during shipping should be removed before use.

Before every ride, check that the mechanisms of the face shield and sun visor are working properly and that the face shield and sun visor will provide sufficiently clear visibility. Any dirt should be removed before riding.

Check the face shield and sun visor for physical damage and cracks. A badly scratched face shield will considerably impair your vision and should be replaced before setting off on a journey.

WARNING

Never use tinted face shield or sun visor in conditions of poor visibility, when riding at night or in a tunnel.

WARNING

A scratched and/or dirty face shield will seriously impair visibility. For your own safety, replace it or clean it immediately.

WARNING

Make sure the face shield and sun visor are always in good condition. A damaged face shield is not suitable for riding and needs to be replaced.

WARNING

Stop riding if visibility is poor.

4. CHECKING THE MAGNETIC CONNECTOR

1. Check the contact pins integrity and cleanliness on the connector and on your helmet.
2. Check if the 4 contact pins top are above the surface of the connector.
3. Check the 4 contact pins spring back on the connector.

E. OTHER IMPORTANT INFORMATION

1. MODIFICATIONS / ACCESSORIES

WARNING

Original components (in particular on the outer shell, inner shell and restraint system) should not be altered or removed.

The fitting of additional parts from other manufacturers that have not been recommended can reduce the protective effect and renders the DOT certification and all warranty and insurance claims invalid.

Use only original parts, replacement parts and accessories that BRP has expressly approved for your helmet!

Modifying your helmet may reduce its ability to protect you and increase your risk of serious injury or death in an accident.

Modifications include the following:

- Drilling holes
- Cutting shell, strap or shock absorbing liner
- Pressing shock absorbing liner
- Modifying the retention system, including adding a chin cup
- Removing parts
- Painting
- Using adhesives
- Installing unapproved accessories

E. OTHER IMPORTANT INFORMATION

2. FROSTBITE

WARNING

What is frostbite?

Frostbite can be defined as the freezing of the skin and/or the bodily tissues under the skin. It is thermal injury that can result from prolonged exposure to moderate cold or brief exposure to extreme cold.

What causes frostbite to occur?

Different factors can contribute to the occurrence of frostbite such as:

- Length of time a person is exposed to the cold;
- Temperature outside;
- Force of the wind (wind-chill factor);
- Humidity in the air;
- Wetness of clothing;
- Previous frostbite or cold injury.

How to prevent frostbite

- Do not go outdoors for prolonged periods in severely cold weather.
- Always wear additional headwear such as a balaclava, neck tube, face mask, or a combination of those items.
- Change any wet clothes immediately.
- Watch for signs of frostbites frequently: Red or pale skin, prickling and numbness.
- Avoid caffeine, tobacco and alcohol when going out in the cold, as these leave the skin more prone to thermal injury;

Sources:

- National Institutes of Health's Website:

<https://medlineplus.gov/frostbite.html>

<https://medlineplus.gov/ency/patientinstructions/000866.htm>

F. CARE AND MAINTENANCE

WARNING

Never use petroleum-based chemicals, solvents, gasoline, cleaning agents or adhesives to clean the shell, liners or visors of your helmet. Your helmet shell, liner and visors may be seriously damaged by the use of such products and the full safety function of the helmet can then no longer be guaranteed.

1. SHELL CLEANING

To clean the helmet shell, you can use water, soap or one of the commonly available motorcycle shampoos, cleaners, polishes, plastic cleaners or cleaning fluids.

Using water and soap is usually sufficient. Make sure when using the other cleaning materials that these do not come into contact with the face shield, since they can cause damage to the visor and its coating.

2. INTERIOR CLEANING

The inner lining of the OXYGEN helmet can be removed completely. The head and cheek pads can be washed by hand using a mild soap solution (e.g. with highly diluted standard mild detergent) at a maximum temperature of 30 °C.

Hand washing is recommended, but machine washing is also permitted. Use the "delicate" cycle to prevent the agitator from damaging the sweat-wicking material covering the liner parts. Allow the lining to dry at room temperature and with good ventilation.

WARNING

Do not place lining parts in the dryer: Excess heat may damage the foam and coverings.

3. OUTER SURFACE OF THE FACE SHIELD

Use a soft cloth and a mild soap solution (< 20 °C) to remove dirt from the outside of the face shield.

To dry the face shield, use a lint-free cloth and apply gentle pressure. The face shield comes with a special fog resistant coating. This coating may lose its effectiveness after approximately two years therefore we recommend you replace your main visor with a new genuine one at least every two years.

4. HEATING LENS

The inside surface of the face shield must only be cleaned with a soft cloth, which may be slightly dampened if required (we recommend a microfiber cloth).

WARNING

Do not use any cleaning agents.

5. ELECTRICAL CONNECTIONS

Use a soft cloth and a mild soap solution (< 20 °C) to remove dirt from the surface of the electrical connections.

To clean the pivot connections, remove the face shield and clean gently the electrical contacts on both sides.

NOTICE

Be very gentle on the spring blades, otherwise you could damage the electrical contact.

F. CARE AND MAINTENANCE

6. SUN VISOR

6.1 CLEANING THE SUN VISOR

The sun visor should only be cleaned with a soft and, if necessary, slightly damp cloth (we recommend a microfiber cloth).

Only use tepid water (< 20 °C) for cleaning. Never on any account clean the face shield or sun visor with petrol, solvent, a window or glass cleaner or other cleaning agents containing alcohol.

The face shield should not be soaked in water even if it is very dirty on the outside, as this will severely reduce the surface hardness and thus the durability of the anti-fog/anti-scratch coating.

Never attach labels, adhesive tape or stickers to the face shield or sun visor.

Stubborn dirt on the outer surface of the face shield (e.g. dried-on insect remains) can be easily removed by covering the closed visor with a moist or wet cloth and allowing the dirt to soften for around 30 minutes to 1 hour.

7. HELMET INSPECTION

Check the face shield and its mechanism. Retighten it, if necessary. Be sure not to overtighten any screws. Base plate screws can break and visor screws can strip screw sleeves if overtightened.

Check for helmet damages. If your helmet is damaged or cracked, stop using it immediately and replace it.

Check for worn or damaged parts. Plastic components may wear out over time. If you find worn or damaged parts, replace them or purchase a new helmet. See "Replacement parts" for information on parts replacement.

WARNING

To reduce the risk of serious injury or death, always inspect your helmet before each ride.

The helmet should be replaced after 3 to 5 years, depending on use and care. Although the outer shell is in principle capable of a longer service life, the occurrence of material fatigue and wear to other components, as well as the overall action of the helmet and the unknown conditions in which the helmet has been used, make it advisable for your own safety to replace the helmet after this period of use.

Excessive heat (e.g. exhaust heat) can cause damage to the decoration, the inner shell of the helmet and the interior lining.

8. HELMET STORAGE

- Store helmet in a cool and dry place;
- Keep helmet away from pets and other animals;
- Keep helmet away from heat more than 50°C (122°F) and do not set on or near hot surfaces;
- Store helmet in a helmet bag.

WARNING

Improperly stored helmet can become damaged.

G. TROUBLESHOOTING GUIDE

PROBLEM	ACTION
REMOTE CONTROL IS NOT POWERED	<p>Check if you are properly connected to your vehicle or another power source. If you are connected to your vehicle, check the fuse on your vehicle. Replace it if necessary. Load shedding might happen on some vehicles, run the engine at higher RPM (Rotation Per Minutes) just a few seconds, it should turn ON the remote control. If the problem is still not resolved, go to your authorized BRP dealer for detailed inspection.</p>
THE RED LIGHT IS LIGHTED ON YOUR REMOTE CONTROL	<p>It means that a short circuit occurs, please check the following:</p> <ol style="list-style-type: none"> 1. Check if there is a foreign object on your magnetic connector and/or on your helmet socket. Remove it and/or clean it if necessary. 2. Check if your magnetic connector or power cable is damaged. Replace it if necessary. <p>If the problem is still not resolved, go to your authorized BRP dealer for detailed inspection.</p> <p><i>Note:</i> <i>If a short circuit occurs, the 3 orange LEDs might remain lighted or might blink several times, in any cases, you should stop immediately your vehicle and follow step by step the procedure as described above.</i></p>
THE GREEN LIGHT STAYS OFF ON YOUR REMOTE CONTROL	<p>It means that your electric visor doesn't work, please check the following:</p> <ol style="list-style-type: none"> 1. Check if your helmet is properly connected. If not, adjust the magnetic connector. 2. Check if there is ice formation inside the pivot electrical contacts. Open and close the main visor several times to create enough friction to remove it. 3. Check if your face shield is properly installed. If not, remove it and reinstall it properly. 4. Check if the electrical contact blades are deformed. Remove your face shield and pull gently the blades (located inside the pivots) to make them go higher (on both sides), and reinstall the face shield on your helmet. 5. Check if the electrical visor is damaged. Replace it if necessary. <p>Your power source is higher than 18 Vdc.</p> <ol style="list-style-type: none"> 7. If the problem is still not resolved, go to your authorized BRP dealer for detailed inspection.
FOG ON THE MAIN VISOR	<p>Check if the heating visor has been damaged. Replace it if necessary.</p> <p>Remove the face shield and check the electrical connection integrity at the pivots. Clean them if necessary.</p> <ol style="list-style-type: none"> 3. If it is still not working, pull very gently on the 3 blades (on each side of the visor) upward, to be sure that they make the electrical contact with the helmet. 4. Replace your face shield if it is damaged.

G. TROUBLESHOOTING GUIDE

PROBLEM	ACTION
THE HEATING VISOR SEEMS HAZY	<ol style="list-style-type: none"> 1. In unusual circumstances, a haze may appear on the surface of the anti-fog coating. This can be easily removed and never reappear by following these steps: <ol style="list-style-type: none"> a. Moisten a soft cloth with warm soapy water. b. Gently clean and let air dry. c. Let air dry without trying to rub dry. d. Repeat if necessary. 2. If the problem is still not resolved, check if the fog seems to be between the two lenses. If this is the case, go to your authorized BRP dealer for detailed inspection.
SUN VISOR DYSFUNCTIONING	<ol style="list-style-type: none"> 1. Check if the sun visor is installed and positioned correctly on the helmet. 2. Check if there are any broken parts. Replace them by new ones if necessary. 3. If the problem is still not resolved, go to your authorized BRP dealer for detailed inspection.
ICE FORMATION ON FACE SHIELD LATCH REAR LIGHT DYSFUNCTIONING FRONT LIGHT DYSFUNCTIONING (SOLD SEPARATELY)	<ol style="list-style-type: none"> 1. Make sure your face shield is properly closed. You should hear/feel a “click”. 2. Make sure you use the breath deflector to reduce water accumulation in this area. <ol style="list-style-type: none"> 1. Check if the rear light has been damaged. Replace it if necessary. 2. If the problem is still not resolved, go to your authorized BRP dealer for detailed inspection. <ol style="list-style-type: none"> 1. Make sure you press the ON button longer than 1 second. To avoid any misuse, there is a 1 second delay before your front light turns ON. 2. Check if the batteries are still good. Replace the batteries by new ones if necessary 3. Check if the electrical contacts in the batteries socket are damaged or dirty; Clean the electrical contacts or replace your front light if necessary. 4. If the problem is still not resolved, go to your authorized BRP dealer for detailed inspection.

H. ACCESSORIES AND SPARE PARTS

You will find a summary of all available accessories and spare parts on internet at www.brp.com

⚠ WARNING

For safety reasons, all accessories should be approved by BRP for that specific helmet.

⚠ WARNING

Use of replacement parts other than the ones offered by BRP may increase your risk of serious injury or death. Only use parts that are specifically designed to work with this helmet. BRP recommends that all replacement parts shall be installed by a BRP dealer.

⚠ WARNING

Never modify your helmet – It may reduce your helmet's ability to protect you and increase your risk of serious injury or death.

1. ACCESSORIES

Original BRP accessories are available at your dealer. To find BRP dealers in your area, use the dealer search on the BRP website: www.brp.com

2. REPLACEMENT PARTS

Original BRP parts are available at your dealer. To find BRP dealers in your area, use the dealer search on the BRP website: www.brp.com

Note: For more information on available replacement parts, please visit our website at the following address: <http://store.ski-doo.com/>

3. LED UTILITY LIGHT INSTALLATION

STEP 1

Remove the neck protector. Start by removing the plastic tab on each side to remove the entire rear portion.



Remove the chin part by pulling the front portion of the neck protector toward the inner side of the helmet as shown.



Using a Phillips n°1 cruciform screw driver, remove the 2 screws.



STEP 2

Once the 2 screws have been removed, grab the part as shown above, and pull it to tilt it backward.



H. ACCESSORIES AND SPARE PARTS

Once you can see entirely the bottom of the part, you can remove it completely.

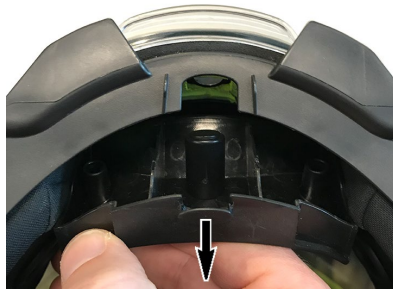

STEP 3

Install the accessory light by positioning the upper corners first, then tilt it forward to put it in position.

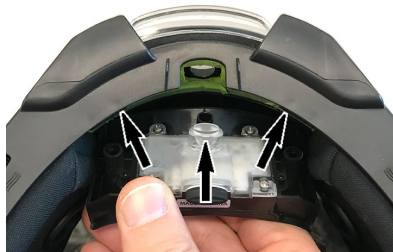

NOTE: You should not have to force to tilt the light in position. If you do, it is because something is wrong, and the corners of the lights have not been positioned correctly.



STEP 4

Once the accessory light is in position, make sure it is in the right position by checking if the lens is perfectly located inside the aperture made for this. If it is not in position, adjust it.



STEP 5

Put back the 2 screws to secure the accessory light in position (0.3 Nm). Reinstall the neck protector, starting by the chin portion.



4. LED UTILITY LIGHT BATTERIES REMPLACEMENT

STEP 1

Using the Phillips #1 screw driver delivered with the LED Utility Light, remove the screws on each side of the utility light batteries cover and set them aside.



Note: Be careful not to drop the screws and/or unscrew the utility light screws.

STEP 2

Grab one side of the batteries door and gently pull on it. Grab the top of the batteries cover and pull it out completely.



STEP 3

Replace the batteries and make sure that they are well positioned.



STEP 4

Put back the batteries cover and gently screw back the screws (0.2 Nm).



NOTICE

Be sure not to over-torque the screws to avoid any damage.

I. BRP SERVICE

1. REPAIR SERVICE

The OXYGEN FLOW helmet is a BRP quality product that has been designed and manufactured using the latest development and production methods. If a repair to your helmet is necessary, please consult your dealer.

If we receive an order from a customer to carry out a repair without a clear description of the fault, we are entitled to examine the item and/or delay completion of the order until the customer has been consulted.

Even where a clear description of the original fault has been provided, if we discover further faults during the repair, we are entitled, but not obliged, to rectify these without a specific order if this is necessary to restore the correct functioning of the helmet and the cost of this is low in relation to the original repair job. Otherwise, we will seek the agreement of the customer.

2. WARRANTY

Your specialist dealers provide a warranty for purchased equipment.

The limited warranty period is 4 years from the purchasing date. Should you have a reason to complain, please contact your specialist retailer or its service address.

We ask that you provide a precise description of the complaint as well as a copy of your receipt.

J. HOW TO CONTACT US

North America

565 de la Montagne Street
Valcourt (Québec) J0E 2L0
Canada

Sturtevant, Wisconsin, U.S.A.
10101 Science Drive
Sturtevant, Wisconsin
53177
U.S.A.

Sa De Cv, Av. Ferrocarril 202
Parque Ind. Querétaro, Lote2-B
76220
Santa Rosa Jáuregui, Qro.
Mexico

Oceania

6 Lord Street
Lakes Business Park
Botany, NSW 2019
Australia

South America

Rua James Clerck Maxwell, 230
TechnoPark Campinas
SP 13069-380
Brazil

Asia

15/F Parale Mitsui Building,8
Higashida-Cho, Kawasaki-ku
Kawasaki 210-0005
Japan

Room Dubai, level 12, Platinum
Tower
233 Tai Cang Road
Xintiandi, Lu Wan District
Shanghai 200

Europe

Skaldenstraat 125
B-9042 Gent
Belgium

Itterpark 11
D-40724 Hilden
Germany

ARTEPARC Bâtiment B
Route de la côte d'Azur, Le
Canet
13590 Meyreuil
France

Ingvald Ystgaardsvei 15
N-7484 Trondheim
Norway

Isoaavantie 7
PL 8040
96101 Rovaniemi
Formvågen 16
S-906 21 Umeå
Sweden

Avenue d'Ouchy 4-6
1006 Lausanne
Switzerland