

can-am



APACHE XC™ AND APACHE XC LT™

USER'S GUIDE

Track Kit Series

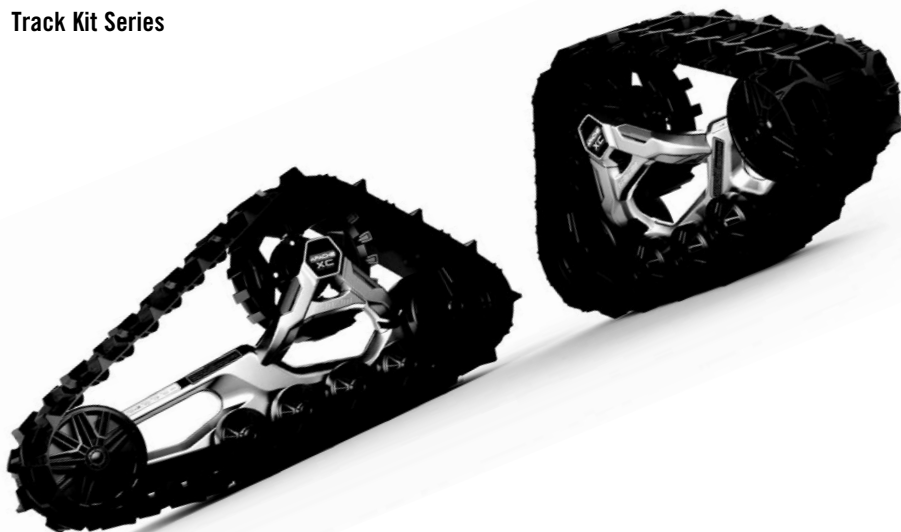

⚠ WARNING

Read this guide thoroughly before operation.
Keep this guide in the vehicle when installed.

219002370

Original Instructions

The types of safety messages, what they look like and how they are used in this guide are explained as follows:

The safety alert symbol  indicates a potential injury hazard.

WARNING

Indicates a potential hazard which, if not avoided, could result in serious injury or death.

CAUTION

Indicates a hazardous situation which, if not avoided, could result in minor or moderate injury.

NOTICE

Indicates an instruction which, if not followed, could result in severely damaged vehicle components or other property.

In Canada, products are distributed and serviced by Bombardier Recreational Products Inc. (BRP).

In the USA, products are distributed and serviced by BRP US Inc.

In the European Economic Area (which is comprised of the member states of the European Union plus the United Kingdom, Norway, Iceland and Liechtenstein), the Commonwealth of the Independent States (including Ukraine and Turkmenistan) and Turkey, products are distributed and serviced by BRP European Distribution S.A. and other affiliates or subsidiaries of BRP.

For all other countries, products are distributed and serviced by Bombardier Recreational Products Inc. (BRP) or its affiliates.

TM Trademarks of BRP or its affiliates.

This is a non-exhaustive list of trademarks that are the property of Bombardier Recreational Products Inc. or its affiliates.

Trademarks may not be registered in every jurisdictions.

Apache XCTM

Can-Am[®]

All rights reserved. No parts of this operator's guide may be reproduced in any form without the prior written permission of Bombardier Recreational Products Inc.

©Bombardier Recreational Products Inc. (BRP) 2024

TABLE OF CONTENTS

INTRODUCTION

INTRODUCTION6

IMPORTANT INFORMATION

TRACK KIT INSTALLATION8

- Steering Alignment8
- CVT Air Intake Relocation Kit.....8
- 4WD Mode Only8
- Towing or Installing an Accessory8
- Riding Surface.....8
- Speedometer Reading8
- Trail Riding.....9
- Regulations.....9

SAFETY INFORMATION

IMPORTANT WARNINGS12

- Effects of Track Kit on the Can-Am Off-Road Vehicle.....12
- Riding a Can-Am Off-Road Vehicle with a Track Kit.....13
- Track Repairs.....15
- Towing a Vehicle out of the Snow15
- Track Kit Modifications16

LOCATION OF THE IMPORTANT LABELS17

- Apache XC.....18
- Apache XC LT20

GENERAL INFORMATION

HOW TO IDENTIFY YOUR TRACK KIT24

EC DECLARATION OF CONFORMITY26

OPERATING INSTRUCTIONS27

- Break-in Period.....27
- Pre-Operation Check27
- Tools to Bring28
- Protective Gear28

MAINTENANCE INFORMATION

MAINTENANCE SCHEDULE30

MAINTENANCE PROCEDURES36

- General.....36
- Track Kit Assembly37
- Tracks41
- Wheels41
- Frame41
- Sprocket43

Cleaning, Storage and Preseason Preparation..... 44

WARRANTY

BRP LIMITED WARRANTY: APACHE™ OFF-ROAD CAN-AM VEHICLE TRACK KIT.....**46**
WARRANTY COVERAGE PERIOD.....46
EXCLUSIONS.....46
CONDITIONS TO HAVE WARRANTY COVERAGE.....46
WHAT TO DO TO OBTAIN WARRANTY COVERAGE.....47
WHAT BRP WILL DO.....47
LIMITATIONS OF LIABILITY.....47
CONSUMER ASSISTANCE.....48

CUSTOMER INFORMATION

DATA PRIVACY INFORMATION.....**50**
CONTACT US.....**52**
Asia Pacific.....52
Europe, Middle East and Africa.....52
Latin America.....53
North America.....53
CHANGE OF ADDRESS AND OWNERSHIP.....**54**

INTRODUCTION

INTRODUCTION

WARNING

All safety rules should be followed as per vehicle Operator's Guide, the specific instructions included in this guide should also be observed when using an Off-road Can-Am vehicle with an Apache XC™ Track Kit.

Congratulations on your purchase of your new BRP Apache XC track kit. It is backed by the BRP warranty and a network of authorized Can-Am dealers ready to provide the parts or service you may require.

It is understood that this User's Guide may be translated into other languages. In the event of any discrepancy, the English version shall prevail. Throughout this document the masculine is used to denote the masculine or feminine.

If you want to view and/or print an extra copy of your User's Guide, visit the following website www.operators-guides.brp.com. Also note that the guide is available in several languages.

The information and components/ system descriptions contained in this document are correct at the time of publication. Bombardier Recreational Products Inc., however, maintains a policy of continuous improvement of its products without imposing upon itself any obligation to install them on products previously manufactured. Due to late changes, some differences between the manufactured product and the descriptions and/or specifications in this guide may occur. BRP reserves the right at any time to discontinue or change specifications, designs, features or equipment without incurring any obligation upon itself.

The illustrations in this document show the typical construction of the different assemblies and may not

reproduce the full detail or exact shape of the parts. However, they represent parts that have the same or similar function.

We recommend genuine BRP products for replacement parts. They've been specifically designed and manufactured to meet BRP's demanding standards.

IMPORTANT INFORMATION

TRACK KIT INSTALLATION

NOTICE

Apache XC and Apache XC LT track kit should only be installed on Can-Am off-road vehicles.

Using an Apache XC track kit on your Can-Am off-road vehicle will change its behavior, particularly in terms of:

- Manoeuvrability
- Traction
- Acceleration
- Braking.

For these reasons, driving a Can-Am off-road vehicle equipped with an Apache XC track kit requires a certain adaptation period. Familiarize yourself to your Can-Am off-road vehicle with the addition of this kit and learn the new vehicle behaviors in all conditions.

⚠ WARNING

Usage of a track kit will affect the driving behavior of your vehicle. To prevent a loss of control of the Can-Am off-road vehicle:

- Always modulate throttle according to conditions.
- NEVER try to spin the tracks.

This could cause debris, snow or ice to be thrown backwards or cause a loss of control.

Steering Alignment

Vehicle steering alignment must be adjusted as per the vehicle *ADJUSTMENT INSTRUCTION SHEET*, and readjusted to vehicle factory specifications when the kit is removed.

CVT Air Intake Relocation Kit

⚠ WARNING

The installation of a CVT air intake relocation kit could be **MANDATORY** for your Can-Am off-road vehicle when the track is used in snow. Without relocating the CVT intake, the stock CVT air intake may become completely obstructed with snow. In this condition, at high load, the drive belt could overheat, break in pieces and start a fire from the CVT enclosure. For more information, please refer to your authorized Can-Am off-road dealer.

4WD Mode Only

Steering control is reduced in 2WD mode. Always use the Can-Am Off-Road vehicle in 4WD mode with a track kit.

Towing or Installing an Accessory

Prior to install any accessories (snow plow, bumper extensions or signaling kit for example), make sure there is no possible interference with the tracks.

Riding Surface

Apache XC and XC LT track kit give optimal performance and durability on snow. Usage of other type of terrain will increase wear on track kit components and vehicle.

Speedometer Reading

Can-Am Off-Road Vehicle Model Year 2014 and Up

For any Can-Am off-road vehicle model year 2014 and up DPS track kit module must be installed. The DPS module will adjust the displayed speed in the cluster and will adjust DPS settings to offer a better riding

experience. DPS track kit is sold separately.

⚠ WARNING

Never ride with DPS track module connected when tires are reinstalled on vehicle. Never ride with the track kit without connecting the DPS module as the speed display will not be accurate in both cases.

Trail Riding

BRP does not recommend riding a Can-Am Off-Road vehicle equipped with a track kit on public trail as it is unlawful in most states or provinces. If you must, first make sure to verify with your local authorities to confirm that it is allowed. Then, minimize the distance you ride on the trail and be thoughtful of other riders and property owners by being careful to avoid damaging the trail.

NOTICE

Sporty driving and quick changes of direction are not advised. These driving styles can cause premature wear and major failures and will not be covered by normal use warranty.

Regulations

Always check local regulations concerning the use of tracks on your Can-Am Off-Road vehicle. Always drive your Can-Am Off-Road vehicle in a responsible manner, respecting the environment and other people's property.

Modifying an "on-road use" homologated L-category or T-category vehicle using this accessory may be prohibited in some countries. A modified "on-road use" vehicle may not be authorized to circulate on public roads

and thus, may only be operated off-road.

Modifying an "on road use" vehicle using this accessory will void its compliance with the following EU regulations:

- Categories T1, T2 or T3 under the Regulation (EU) No 167/2013 of the European Parliament and of the Council of February 5th, 2013, on the approval and market surveillance of agricultural and forestry vehicle.
- Categories L5 or L7 under the Regulation (EU) No 168/2013 of the European Parliament and of the Council of January 15, 2013, on the approval and market surveillance of two- or three-wheel vehicles and quadricycles.

This page is intentionally blank

SAFETY INFORMATION

IMPORTANT WARNINGS

Can-Am OFF-ROAD VEHICLE EQUIPPED WITH AN APACHE XC TRACK KIT CAN BE HAZARDOUS TO OPERATE.

SEVERE INJURY OR DEATH can result if you do not follow these instructions:

- Read this User Guide and follow the operating procedures described.
- Read the vehicle Operator's Guide and all on-product safety labels carefully and follow the operating procedures described.
- If any accessories are installed, make sure to read all on-product safety labels carefully and follow the operating procedures described.

Effects of Track Kit on the Can-Am Off-Road Vehicle

Vehicle Weight

Vehicle weight is increased when track kit is installed and must be taken into consideration when crossing a bridge or any other situations where vehicle weight can be a factor. Vehicle weight should also be considered when using lifting equipment to lift vehicle off the ground or when transporting your vehicle on a truck or trailer.

Vehicle Width

Total vehicle width is increased with tracks as they extend beyond vehicle fenders. Additional care must be taken when maneuvering in proximity of obstacles or when crossing a bridge, or any other situations where the vehicle width can be a factor.

Vehicle Height

Vehicle total height is increased with tracks and must be taken into consideration in any situations where the vehicle height can be a factor.

Vehicle Towing Capacity

Installation of the track kit **DOES NOT** increase the vehicle towing capacity.

Vehicle Load

NOTICE

The track kit weight should be taken into consideration when calculating the vehicle loads.

Installation of the track kit **DOES NOT** increase vehicle load limit.

Vehicle Heat Dissipation

The use of a track kit may increase heat generated by the vehicle in certain conditions:

- Extended deep snow riding
- Extended low speed riding
- Extended plowing
- Extended towing at low speed.

For these severe duty applications, it is recommended to use an Off-Road Can-Am vehicle heat dissipation kit (if not already installed from factory).

Vehicle Air Intake

Ensure to check for any mandatory air intake relocation kits that could be required for your Can-Am Off-Road vehicle when fitted with track kits. Always pay attention to the vehicle engine and/or CVT air intake to make sure it is clean of any debris/snow accumulation.

⚠ WARNING

Snow spray may clog transmission and engine air intake filters increasing the risk of malfunction and overheating.

- **Periodically clean both filters during the ride to make sure fresh air flows normally.**

⚠ WARNING

The installation of a CVT air intake relocation kit could be **MANDATORY** for your Can-Am off-road vehicle when the track is used in snow. Without relocating the CVT intake, the stock CVT air intake may become completely obstructed with snow. In this condition, at high load, the drive belt could overheat, break in pieces and start a fire from the CVT enclosure. For more information, please refer to your authorized Can-Am off-road dealer.

aware that the obstacle may be slippery or may move while crossing.

⚠ CAUTION

The steering system is strongly solicited when crossing obstacles. Therefore, sudden and unpredictable steering jerks may arise when crossing obstacles.

To facilitate driving over large obstacles, insert a log or rock in front of the obstacle to lower its height.



Riding a Can-Am Off-Road Vehicle with a Track Kit

Avoid driving on any frozen waterways before checking that the ice will safely support the vehicle, its riders and its load of cargo.

⚠ WARNING

Even if frozen waterways are supporting snowmobiles or other vehicles does not mean your vehicle will be supported. This vehicle is heavier, slower and less maneuverable than a snowmobile.

Traction/Acceleration

This track kit will allow your Can-Am Off-Road vehicle to have better traction and acceleration on soft surfaces. This can cause sudden variations in traction with changing conditions.

Crossing Obstacles

Avoid obstacles including rocks and fallen trees whenever possible, also avoid deep and square edged ditches. Remember that some obstacles are too large or dangerous to cross and should be avoided. As a guideline, never attempt to cross an obstacle higher than the center of the upper front wheel track. Small rocks or small fallen trees may be safely crossed - approach obstacle at low speed and as much as possible at a right angle. Adjust speed without losing momentum and do not accelerate abruptly. Passenger must grasp handholds firmly and brace feet on the floor. Be

⚠ WARNING

Sudden changes on ridden surface conditions will affect traction. You may lose control.

Braking

This track kit will give you better braking on snow but will have no noticeable effect on ice. Braking may thus vary suddenly under certain conditions. Always modulate brakes and be alert for changing conditions to avoid locking the tracks.

Snow or ice may affect the response time of the brake system of your

Can-Am Off-Road vehicle even with a track kit.

⚠ WARNING

Snow spray may create ice film on brake rotors increasing stopping distances.

- Apply brakes periodically while riding to break ice film.
- Allow more distance to stop.

Depending on the condition, stopping may require more distance than you think. Be prepared for the unexpected. Play it safe.

⚠ WARNING

Locking the tracks under braking may lead to a loss of control.

Turning

Vehicle steering turning radius is decreased. Adjust your driving accordingly. Never perform sharp turns above 25 km/h (16 MPH), this could result in loss of control or damage to the track kit.

Steering control is reduced in 2WD mode. Always use the Can-Am Off-Road vehicle in 4WD mode with a track kit.

Vehicle Speed

The Can-Am Off-Road vehicle should be used only at reduced speed. The vehicle handling, stability and braking distance may be affected with the track kit installed. Always adjust speed according to terrain, visibility,

operating conditions and your experience.

⚠ WARNING

Snow spray may create ice film on brake rotors increasing stopping distances.

- Apply brakes periodically while riding to break ice film.
- Allow more distance to stop.

Snow Plow

If the Can-Am Off-Road vehicle is also equipped with a snow plow, vehicle speed should not exceed 5 km/h (3 MPH).

Driving in Reverse

Always drive in reverse at reduced speed. Driving in reverse at high speed, especially when going down a hill, could cause the tracks to plunge into the snow or obstacles and cause severe damages to the Can-Am Off-Road vehicle.

NOTICE

If one or both rear tracks get stuck in the snow when reversing, avoid moving or towing the vehicle in reverse to ease it from its position, as this could lead to a malfunction of the tracks. If possible, move or tow vehicle forwards to free it from the snow.



Snow and Ice Conditions

Due to track kit configuration, there is more snow projections when the track kit is installed therefore, action of steering, suspensions and brakes could be affected from ice buildup or snow accumulation. Always perform a pre-operation check BEFORE you turn on the ignition.

⚠ WARNING
Snow spray may create ice film on brake rotors increasing stopping distances.
<ul style="list-style-type: none"> - Apply brakes periodically while riding to break ice film. - Allow more distance to stop.

Deep Snow

⚠ WARNING
Snow can hide many obstacles.

Riding in deep snow can be hazardous and may hide objects or unexpected terrain.

Vehicle ECO mode

The use of ECO mode is not recommended with tracks.

Jumps

Never attempt jumps or other stunts.

Debris

Projections of debris can be more frequent and severe. Never stands beside or nearby the Can-Am Off-Road vehicle when in motion. Never ride without proper equipment, including eye protection.

The faster the speed, the more projections there will be. Slow down according to conditions.

NOTE:

It is recommended to stop every now and then to clear headlights and taillights of any snow or debris accumulation. Also clear the CVT, the engine air intakes and any accumulation near the vehicle controls (brakes, accelerator, steering).

Bystanders

⚠ WARNING
Never allow any persons nearby the Can-Am Off-Road vehicle when in operation.

Tracks shall not be used as sidesteps. Vehicle movement could cause injury. Tracks exceed width of vehicle fenders and can be hazardous for bystanders. Never allow anyone to push or pull the Can-Am Off-Road vehicle when the engine is running.

Track Repairs

No repair is allowed on the track. If worn or cut, replace track. See your authorized dealer.

Towing a Vehicle out of the Snow

NOTICE
Always tow vehicle in the opposite direction in which you were going when the vehicle got stuck.





NOTICE

When towing vehicle, always attach towing cable to the frame of the vehicle, never on the track kits.



Track Kit Modifications

Do not modify the track kit or install traction enhancing devices such as track studs. Any modifications will void the warranty.

LOCATION OF THE IMPORTANT LABELS

Read and understand all safety labels. These labels are affixed to the tracks and vehicle for the safety of the operator, passenger, or bystanders. The labels should be considered permanent parts of the track kit. If missing or damaged, they can be replaced free of charge. See an authorized Can-Am dealer.

NOTE:

In the event of any discrepancy between this guide and the track kit, the safety labels on the track have precedence over the labels in this guide.

Apache XC

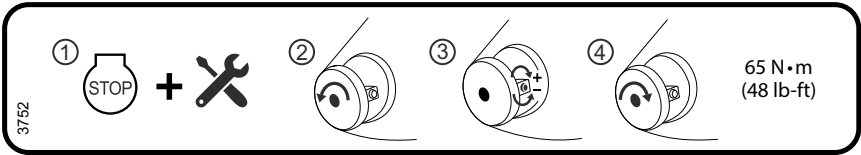

NOTE: Refer to *Maintenance Procedures* for the complete adjustment procedure.

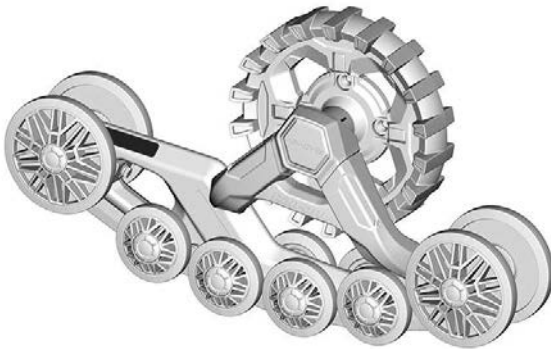

FRONT



REAR

▲ WARNING

To avoid serious injury or death.

- ALWAYS follow the installation instructions of this track kit.
- Pinch point, keep clear hands or fingers from moving parts, turn engine off before servicing track systems.

3769

- To avoid serious injury or death.
- ALWAYS follow the installation instructions of this track kit.
 - Pinch points, keep clear hands or fingers from moving parts, turn engine off before servicing track system.

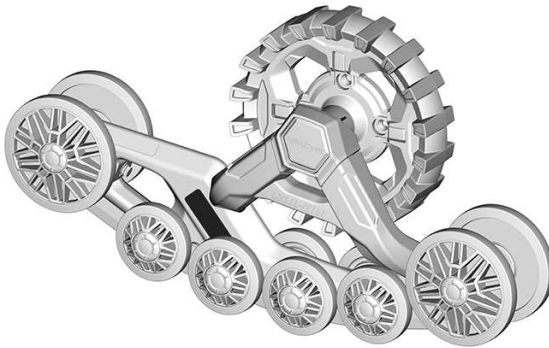

3769

**FRONT****REAR**

Apache XC LT

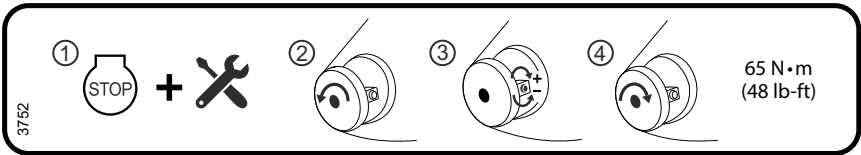

NOTE: Refer to *Maintenance Procedures* for the complete adjustment procedure.

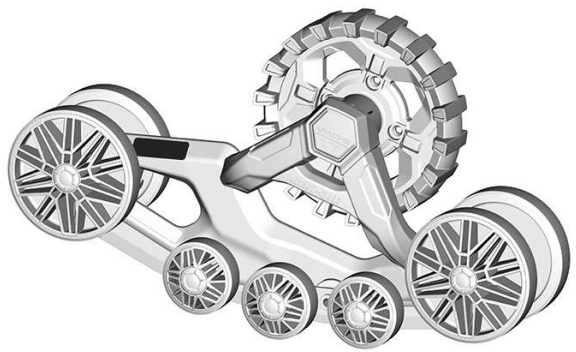

FRONT

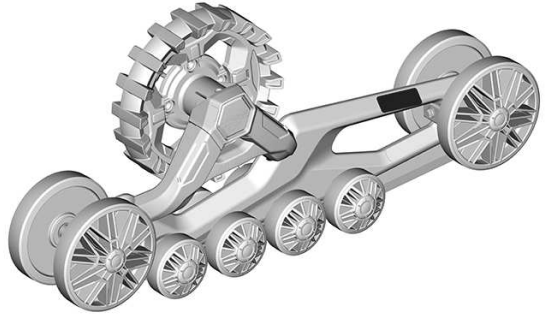

REAR

▲ WARNING

To avoid serious injury or death.

- ALWAYS read the User's Guide and follow all safety rules before attempting to operate a vehicle equipped with track system.

3782

- To avoid serious injury or death.
- ALWAYS read the User's Guide and follow all safety rules before attempting to operate a vehicle equipped with track system.

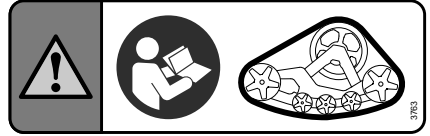

3783

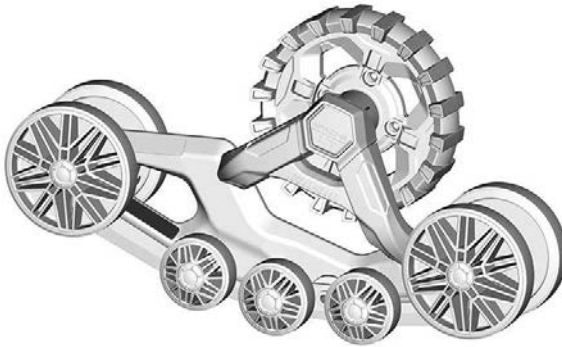

FRONT

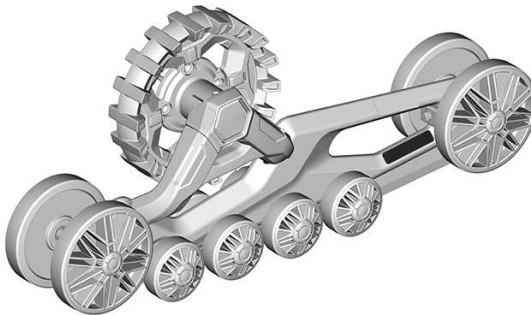

REAR

This page is intentionally blank

GENERAL INFORMATION

HOW TO IDENTIFY YOUR TRACK KIT

Apache XC

Each Apache XC kit bears identification decals. The identification number will be useful for parts ordering or technical support programs from BRP. The identification number is also useful if parts are stolen. **Carefully** note all characters in the appropriate spaces in the following image.

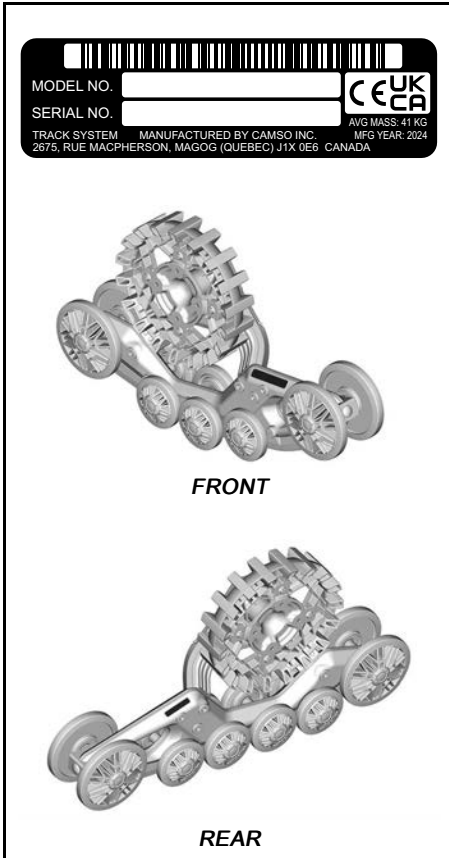

These labels indicate the proper location of each track: front left, front right, rear left, rear right. They are visible both on frame and attachments.

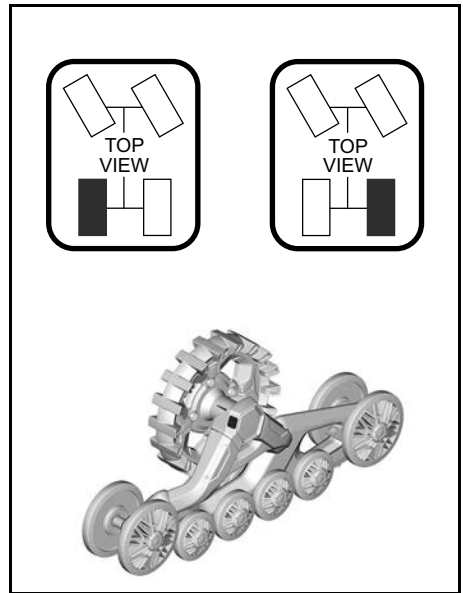
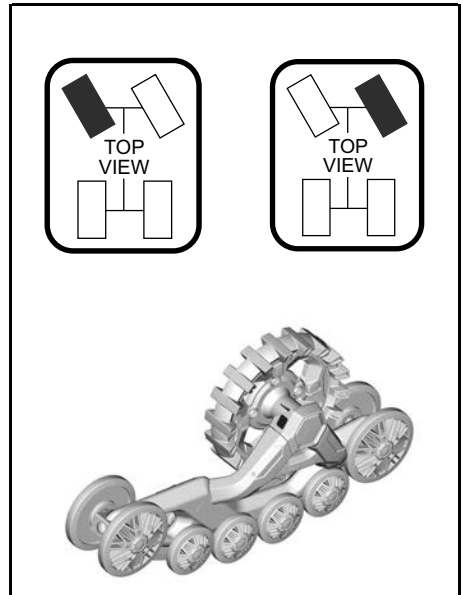

Apache XC LT

Each Apache XC LT kit bears identification decals. The identification number will be useful for parts ordering or technical support programs from BRP.

The identification number is also useful if parts are stolen. **Carefully** note all characters in the appropriate spaces in the following image.



MODEL NO. **CE UK CA**

SERIAL NO. AVG MASS: 52 KG
MFG YEAR: 2024

TRACK SYSTEM MANUFACTURED BY CAMSO INC.
2675, RUE MACPHERSON, MAGOG (QUEBEC) J1X 0E6 CANADA



FRONT



REAR

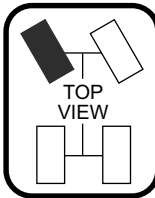

TOP VIEW

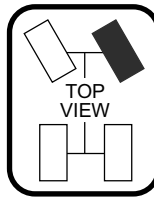

TOP VIEW

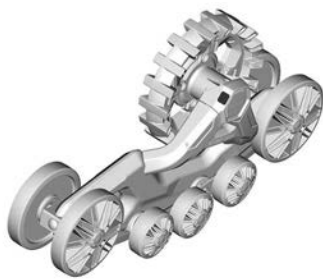

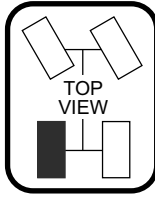

TOP VIEW

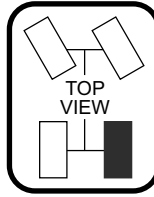

TOP VIEW



EC DECLARATION OF CONFORMITY

DECLARATION OF CONFORMITY



WE:

MANUFACTURER: Camso Inc.

ADDRESS (CANADA): 2675, rue MacPherson, Magog (Québec), Canada J1X 0E6

ADDRESS (EUROPE): Camsotech European R&D Centre NV, Eddastraat 40/3,
9042 Gent, Belgium

ADDRESS (UK): Camso UK Limited, 35a Vale Business Park, Llandow,
Cowbridge, Vale of Glamorgan, CF71 7PF

WEB SITE: www.camso.co

HEREBY DECLARE THAT THE PRODUCT SERIES:

PRODUCT: Apache XC / Apache XC LT

IS IN CONFORMITY WITH THE FOLLOWING STANDARDS:

NUMBER:	TITLE:	DATE:
IEC/EEE 82079-1	Preparation of information for use of products	2019
ISO 12100	Safety of Machinery	2010
ISO/IEC 17050-1&2	Conformity Assessment	2005

AND IN CONFORMITY WITH THE FOLLOWING EC DIRECTIVE:

NUMBER:	TITLE:	DATE:
2006/42/EEC	Safety of machinery directives	2006

DONE AT:

Magog (Québec), Canada

PERSON-IN-CHARGE: TOMMY LEDUC, ing

TITLE: POWERSPORTS SYSTEMS MANAGER

SIGNATURE: [Signature]

DATE: 2024/03/14



OPERATING INSTRUCTIONS

Break-in Period

CAUTION

A break-in period is necessary to allow the components to adjust and settle.

The brake-in period should last 4 hours or 80 kilometers (50 miles), and the following should be verified:

VERIFICATION	Hr 0	Hr 1 15 km/h (9 MPH)*	Hr 2 15 km/h (9 MPH)*	Hr 3 15 km/h (9 MPH)*
Visual Inspection	x	x	x	X
Track Inspection	x	x		
Anti-rotation adjustment	x	x		
Alignment	x			X
Mounting kit bolt torque				X

* *Maximum Real Speed*

Avoid performing break-in period in dry and clean conditions as this can generate smoke, odours of burnt rubber and lead to plastic deposits on the sprocket and/or frame.

An ideal break-in period is performed in a lubricated environment such as water, mud, snow, soft soil, sand, dust, etc.

The break-in period should also serve as a way to familiarize yourself with the changed vehicle behavior.

Pre-Operation Check

Track Kit Pre-Ride Inspection

WARNING

Riding with a damaged track system could lead to a loss of control.

Visually inspect all track kit components before each ride including:

- Tracks
- Frames
- Wheels
- Antirotation system

NOTE:

Inspect also the track section on the ground. It is required to move the Can-Am Off-Road vehicle approximately 1 m (40 in).

Verify tracks and idler wheels for free movement.

Verify tracks tension for proper adjustment.

Remove mud, snow and ice build up from:

- Front and rear suspension
- Steering and brake mechanism
- Inside each track assembly
- Radiator fan (if applicable).

- Any exposed moving part such as prop. shaft or half shaft

Verify that the angle of attack of the track is properly adjusted. Refer to adjustment instruction sheet on:

<https://instructions.brp.com/>

⚠ CAUTION

Improper adjustment of the attack angle can increase steering effort and impact obstacle crossing abilities.

Track Mounting Kit

Visually inspect the anti-rotation bars, fixation bolts, pivot, spring and rubber of the track mounting kit.

Tools to Bring

Apache XC model, bring:

- 1/2" socket wrench
- 18 mm x 1/2" socket
- 19 mm x 1/2" socket
- 17 mm x 1/2" socket
- 24 mm wrench or adjustable wrench
- 19 mm wrench
- flat screwdriver

An axe and a shovel could also be useful.

You should also bring a spare belt as well as the tools needed to replace it.

Protective Gear

⚠ CAUTION

Wear appropriate protective gear.



Avoid loose clothing and wear appropriate protective gear for the ride planned or the work to be performed.

MAINTENANCE INFORMATION

MAINTENANCE SCHEDULE

Maintenance is very important for keeping your Apache XC track kit in safe operating condition. Proper maintenance is the owner's responsibility. The track kit should be serviced as per the maintenance schedule.

The maintenance schedule does not exempt the pre-ride inspection.

WARNING

Failure to properly maintain the track kit according to the maintenance schedule and procedures can make it unsafe to operate.

Make sure to perform proper maintenance at recommended intervals as indicated in the tables.

The maintenance chart intervals are based on 2 factors:

- Vehicle hours
- Odometer reading.

Take in account whichever comes first to determine the maintenance threshold.

Your driving habits determines the factors you shall adhere too. For example:

- Someone who uses their vehicle every other weekend trail riding with friends would most likely follow the **odometer reading** to determine the maintenance interval.
- Someone who uses their vehicle daily / weekly for long periods of time such as agricultural / work would most likely follow the **vehicle hours** to determine the maintenance interval.

Regular Maintenance Overview

Vehicle Hours	Odometer	Regular Duty
40	600 km (375 mi)	A
80	1200 km (750 mi)	A and A+
120	1800 km (1125 mi)	A
160	2400 km (1500 mi)	A and A+
200	3000 km (1875 mi)	B

Severe Duty and Mud/Water Maintenance Overview		
Vehicle Hours	Odometer	Severe Duty and Deep Mud / Water
25	375 km (234 mi)	A
50	750 km (469 mi)	A and A+
75	1125 km (703 mi)	A
100	1500 km (938 mi)	A and A+
125	1875 km (1172 mi)	A
150	2250 km (1406 mi)	A and A+
175	2625 km (1641 mi)	A
200	3000 km (1875 mi)	B

REGULAR WINTER DUTY	A	A+	B
A = Adjust C = Clean I = Inspect L = Lubricate R = Replace T = Torque	Every 40 hours	Every 80 hours	Every year
First Use			
Adjust vehicle alignment, track tension and track attack angle. Refer to break-in period table.			
Storage			
Clean track kit and release track tension.			
System			
Bolt torques			I, A
Vehicle alignment			I, A
Track			
Tension	I, A		I, A
Wear			I
Wheels			
Wear			I
Bearings			I
Seal lubrication		L	I, L
Frame			
Hub bearings			I, R
Hub bearings seal		I, L	I, L
Hub			L
Track guide wear			I, R
Stabilizers and shafts			I, R
Tensioner			L
Cracks			I
Sprocket			
Wear			I
Antirotation and Mount			
Bolt torques			I, A
Attack angle		I, A	I, A

REGULAR WINTER DUTY	A	A+	B
A = Adjust C = Clean I = Inspect L = Lubricate R = Replace T = Torque	Every 40 hours	Every 80 hours	Every year
Vehicle*			
Suspension	I, A		I, A
Direction	I, A		I, A

*For an extensive list of maintenance actions to be performed, refer to your local dealership.

SEVERE HEAVY DUTY OR DEEP MUD / WATER	A	A+	B
A = Adjust C = Clean I = Inspect L = Lubricate R = Replace T = Torque	Every 25 hours	Every 50 hours	Every 200 hours
First Use			
Adjust vehicle alignment, track tension and track attack angle. Refer to break-in period table.			
Storage			
Clean track kit and release track tension.			
System			
Bolt torques			I, A
Vehicle alignment			I, A
Track			
Tension	I, A		I, A
Wear			I
Wheels			
Wear			I
Bearings			I
Seal lubrication		L	I, L
Frame			
Hub bearings			I, R
Hub bearings seal		I, L	I, L
Hub			L
Track guide wear		I, R	I, R
Stabilizers and shafts			I, R
Tensioner			L
Cracks			C, I
Sprocket			
Wear			C, I
Antirotation and Mount			
Bolt torques			I, A

SEVERE HEAVY DUTY OR DEEP MUD / WATER	A	A+	B
A = Adjust C = Clean I = Inspect L = Lubricate R = Replace T = Torque	Every 25 hours	Every 50 hours	Every 200 hours
Attack angle		I, A	I, A
Vehicle*			
Suspension	I, A		I, A
Direction	I, A		I, A

*For an extensive list of maintenance actions to be performed, refer to your local dealership.

MAINTENANCE PROCEDURES

General

⚠ WARNING

Engine should not be running for all maintenance procedures.
--

⚠ CAUTION

Let engine cooled down prior to undertake maintenance.
--

⚠ WARNING

Should removal of a locking device (e.g. lock tabs, self-locking fasteners, etc.) be required when undergoing disassembly/assembly, always replace with a new one.
--

The following covers the maintenance items that can be performed by the customer if desired. Other items found in maintenance schedule must be performed by an authorized Can-Am dealer.

Track Kit Assembly

Apache XC - Front

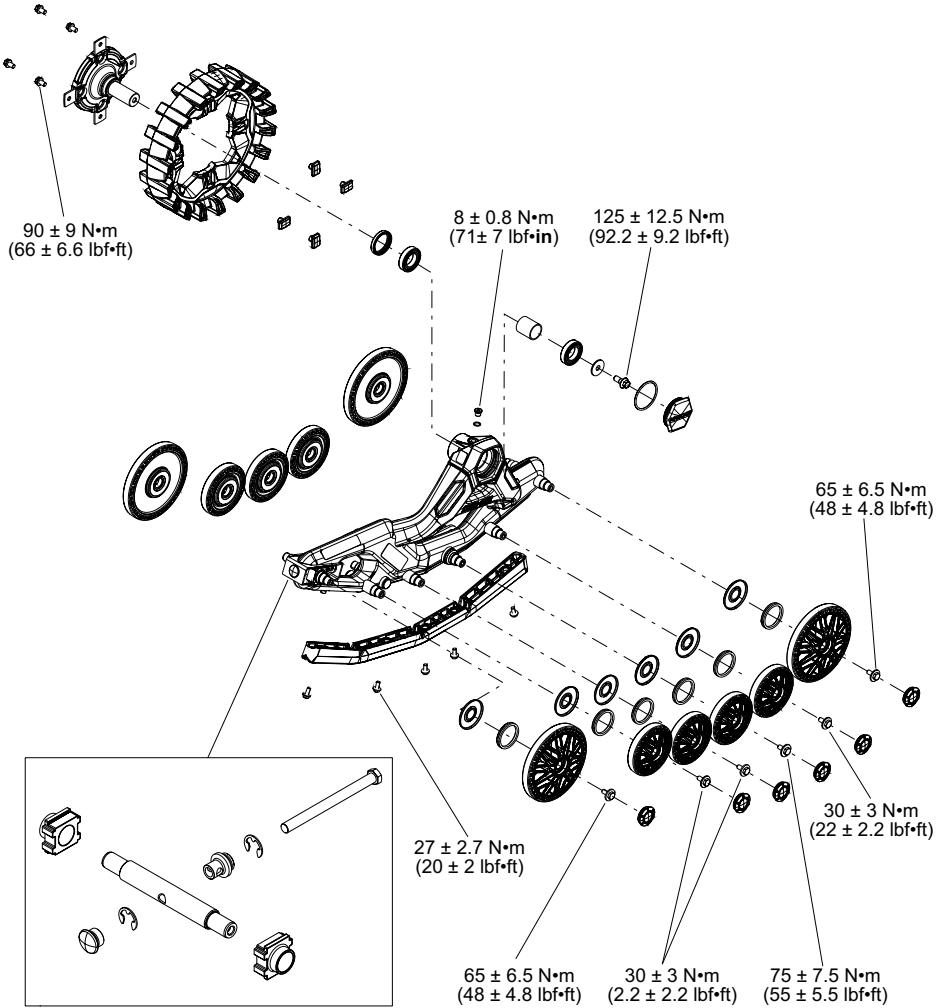

Apache XC - Rear

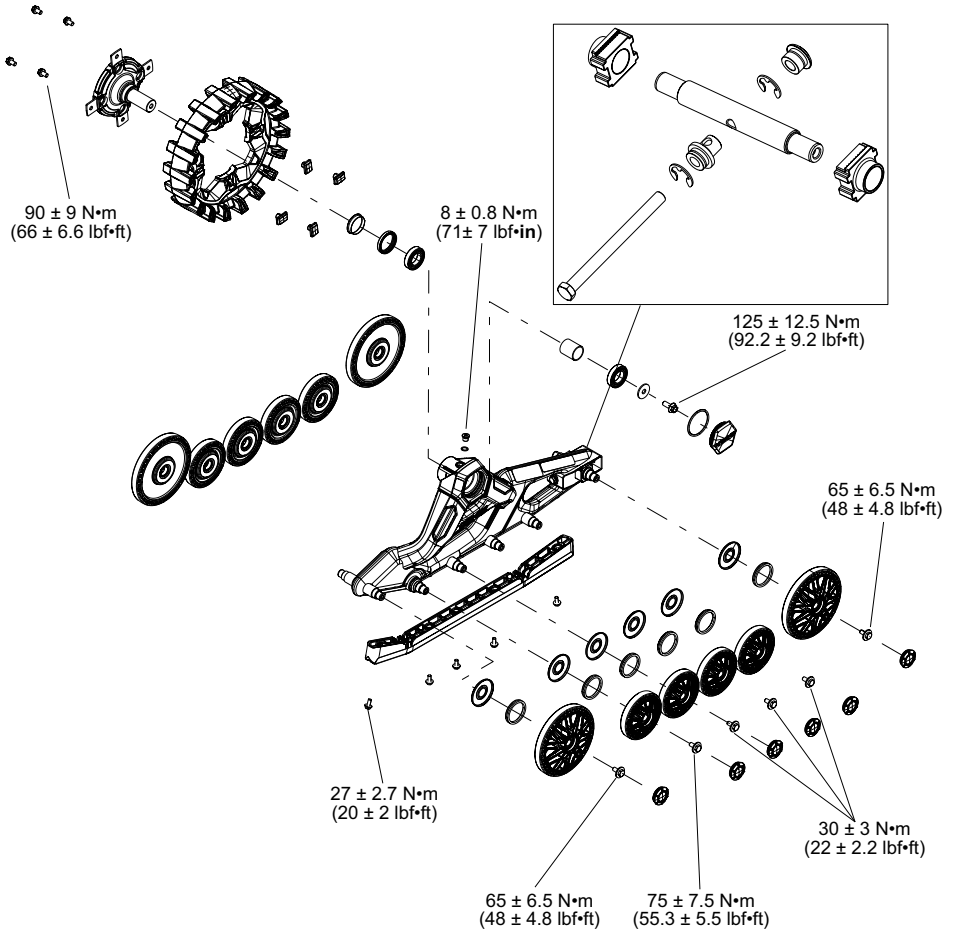

Apache XC LT - Front

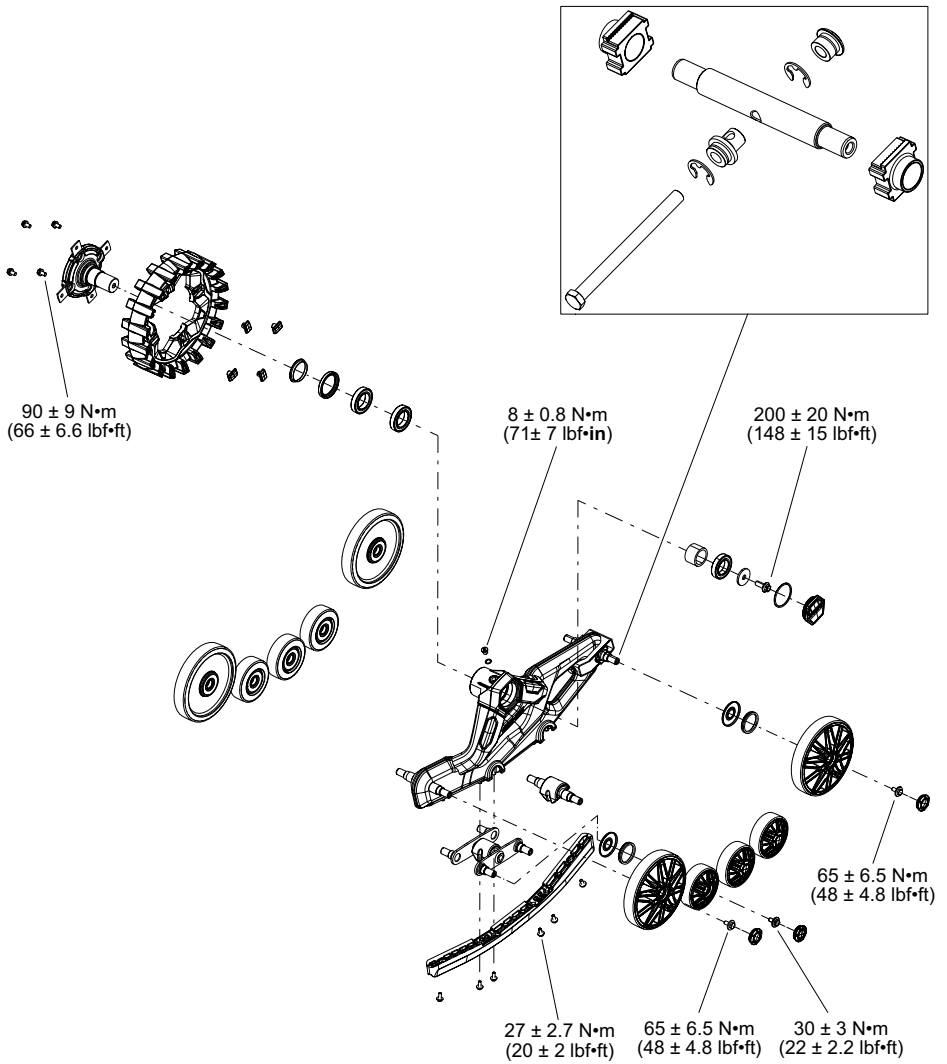

Apache XC LT - Rear

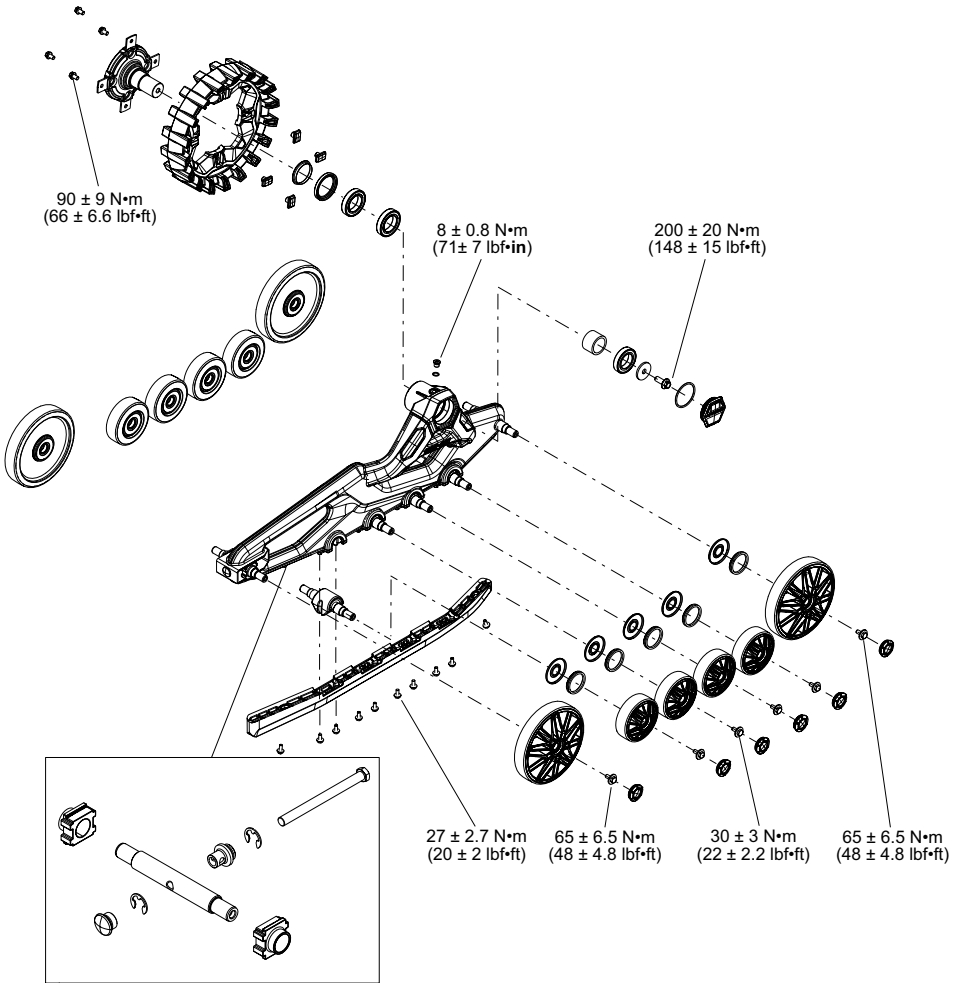

Adjust

1. Verify and adjust the attack angle of the tracks if necessary. Refer to instruction sheet on <https://instructions.brp.com/>.
2. Verify and reapply torque to critical bolts. Refer to exploded view of your kit.

Inspect

1. Visually inspect track kit to detect any defect or anomaly that can impair proper functioning.

Tracks

Adjust

1. Verify and adjust track tension if necessary. Refer to your kit's adjustment instruction sheet.

Inspect

1. Visually inspect track conditions. If worn or cut, or if track fibers are exposed, replace track. See your authorized dealer.

Wheels

Inspect

1. Visually inspect each wheel on your track kit. Check for side wear, especially on the interior guidance strip. If wheel width is less than 34 mm (1 11/32 in) (Apache XC LT) or less than 22 mm (7/8 in) (Apache XC), the wheel should be replaced.

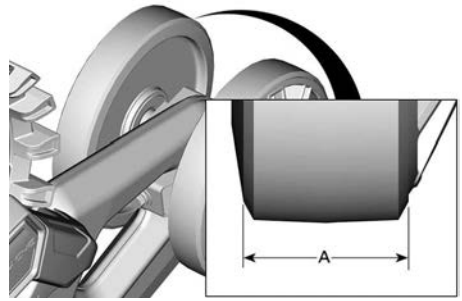

- A >34 mm (1 11/32 in) for XC LT
 - A >22 mm (7/8 in) for XC
2. Check wheel bearing for restriction, noise, or abnormal play in rotation. Replace bearing if it shows one of these defects.

Lubricate

1. Wheel seals must be cleaned of any dirt or contaminant and lubricated.

NOTE: Installing new seals when doing wheel maintenance is recommended.

NOTE: Lubrication done at the recommended intervals allows the wheel seals to maintain optimal sealing action and prolongs the useful lifespan of the wheels.

Frame

Inspect

1. Inspect frame for presence of cracks or defects that can impair proper operation of the track kit assembly.
2. Inspect hub bearings. Check for restriction, noise, or abnormal play in rotation. Bearings must be replaced if they present a defect.

NOTICE

If a hub bearing shows a defect replace all hub bearings, and replace hub bearings on all 4 track assemblies at the same time.

3. Inspect track kit guide. Replace guide if rail dimensions are less than 5mm at any point along the guide or if the rails are worn to the point that the concave shape is no longer visible.

NOTICE

An overly worn track guide could cause premature wear and damage on other guidance components of the system, which could lead to increased track dislodgement occurrences.

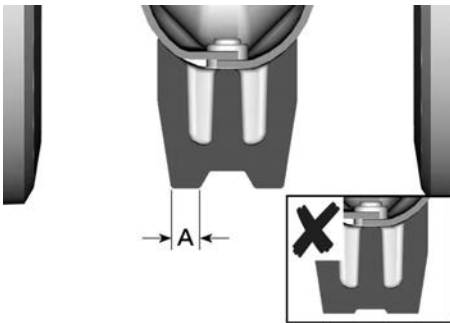

- A >5 mm (13/64 in)

4. Check condition of vulcanized rubber envelopes around Stabilizers and Wheels Shafts embedded in the frame (Apache XC LT kit only). Stabilizers and Wheel Shafts must be perfectly centered in the frame. Lateral play may indicate that the envelope no longer strongly adheres to the Stabilizer or Wheel Shaft. Replace problem component if it is not well supported in the vulcanized rubber envelope.

NOTICE

Replace part if vulcanized rubber component is ungluing from metal tubing. Using the parts when the bond between the two components is broken can result in wear and important damage to the track kit assembly.

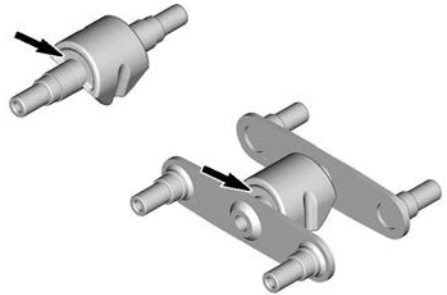

Lubricate

1. Lubricate hub bearing seal. Apply evenly 2 ml (0.07 fl oz (US)) of grease between the hub seal lips and on the entire circumference (360°). The hub seal **must** be installed flush with the hub face.

NOTICE

Replace hub seal immediately if defective.

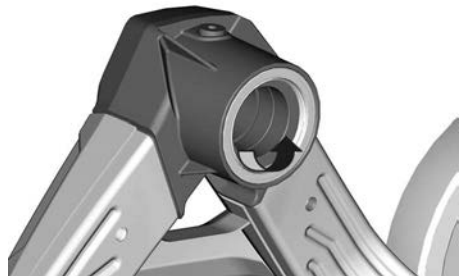

2. Lubricate hub wear sleeve. Apply 2 ml (0.07 fl oz (US)) of grease over the entire width and

circumference (360°) of the hub wear sleeve.

NOTICE

Replace hub wear sleeve immediately if it shows wear.

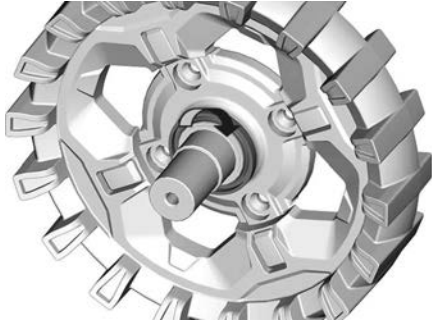

3. Lubricate hub following replacement of hub and/or reinstallation of hub, pour 25 ml (0.85 fl oz (US)) of oil through the hole on top of the hub housing.

NOTE: Use SAE 80W-90 grade oil designed for high pressure applications.

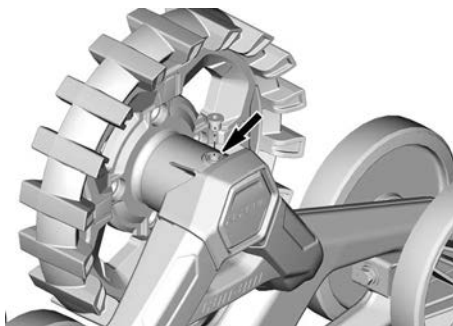

4. Lubricate track tensioner bolt by loosening the track tensioner assembly and applying aerosol grease on the bolt. Following application of grease, rotate adjustment bolt to move the track tensioner to its maximum and minimum positions. Readjust track tension afterwards. For more details, refer to

adjustment instruction sheet on <https://instructions.brp.com/>

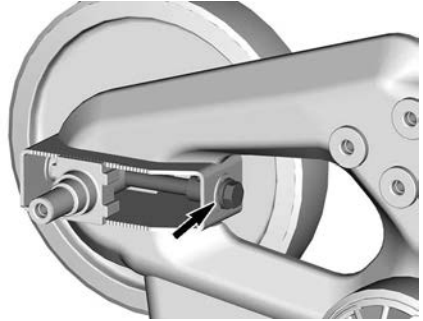

Sprocket

Inspect:

Check wear of sprockets on track assemblies.

Measure sprocket teeth as shown below.

Replace sprocket if dimensions are less than 20 mm (25/32 in).

NOTICE

For wear to occur evenly on all four sprockets, the vehicle should be driven in 4x4 mode, especially in abrasive conditions.

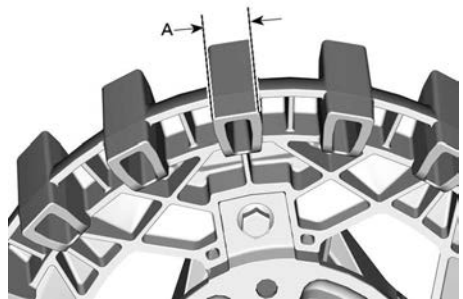

A. > 19 mm (3/4 in)

Cleaning, Storage and Preseason Preparation

Cleaning

NOTICE

Never use a high pressure washer to clean track kit. Use low pressure only (such as a garden hose). High pressure can cause mechanical damages.

Wash each track assembly with hot water and soap (use only mild detergent).

NOTICE

Never clean plastic parts with strong detergent, degreasing agent, paint thinner, acetone etc.

Painted parts which are damaged should be properly repainted to prevent rust.

Storage

Before storing the Track System, it is important to perform the recommended annual maintenance. Refer to the maintenance schedule for maintenance tasks to be done.

NOTICE

Always clean up track kit before storage and remove tension from tracks.

NOTICE

Tracks assembly has to be stored in a cool and dry place and covered with an opaque tarpaulin. This will prevent sun rays and grime from affecting components durability or finish.

Store Apache XC tracks by laying them on their sides with the outside of the tracks facing up, as shown below.

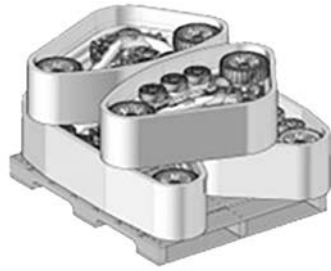

TYPICAL

NOTICE

If vehicle is to be stored with track kit installed, it is recommended to jack the vehicle by the frame to relieve pressure on the traction lugs.

Preseason Preparation

Refer to the maintenance schedule for maintenance tasks to be done.

Proper Recycling

When replacing components or when a track kit comes to its end of useful life, bring components to a recycling facility according to type of material. Follow local regulations for proper disposal.

WARRANTY

BRP LIMITED WARRANTY: APACHE™ OFF-ROAD CAN-AM VEHICLE TRACK KIT

WARRANTY COVERAGE PERIOD

Bombardier Recreational Products Inc. ("BRP")* warrants from the date of original retail purchase that each genuine Apache XC™ Can-Am Off-Road vehicle track kit ("Apache XC") sold as new and unused and installed by an authorized Can-Am Off-Road vehicle dealer will be free from defects in material or workmanship for a period of:

- XC and XC LT track kits: **TWENTY-FOUR (24) CONSECUTIVE MONTHS**, subject to the conditions described below.

The Apache XC cannot be registered as a genuine accessory and therefore does not carry the same warranty of a Can-Am Off-Road vehicle.

The repair or replacement of parts or the performance of service under this warranty does not extend the life of this warranty beyond its original expiration date.

EXCLUSIONS

The following are not warranted under any circumstances:

- Normal wear and tear items;
- Labor and parts cost of all maintenance and adjustment services;
- Damage caused by failure to provide proper maintenance, as described in the User's Guide;
- Damage resulting from removal of parts, improper repairs, service, maintenance, modifications or use of parts not manufactured or approved by BRP or resulting from repairs done by a person that is not an authorized Can-Am dealer;
- Damage resulting from abuse, abnormal use, neglect or operation of the product in a manner inconsistent with the recommended operation described in the User's Guide;
- Damage resulting from accident, fire, theft, vandalism or any act of God;
- Incidental or consequential damages or damages of any kind including without limitation towing, storage, telephone, rental, taxi, inconvenience, insurance coverage, loan payments, loss of time, loss of income;
- Damages caused by the Apache XC being on a vehicle that is not a Can-Am Off-Road vehicle stated as compatible;
- Damages resulting from traction studs installed in or on the track kit.
- Costs of transportation or shipping incurred in respect of the performance of this warranty.

CONDITIONS TO HAVE WARRANTY COVERAGE

This warranty coverage is available **only** if **each** of the following conditions has been fulfilled:

- The Apache XC must be purchased, by its first owner, as new, unused, and installed by a dealer authorized to distribute Apache XC in the country in which the sale occurred ("Can-Am Off-Road vehicle Dealer").
- The BRP specified pre-delivery inspection process must be completed, documented, and signed by the purchaser.
- The Apache XC must have undergone proper warranty registration by an authorized Can-Am Off-Road vehicle Dealer.

- The Apache XC must be purchased in the country in which the purchaser resides.
- Routine maintenance must be performed as indicated in the User's Guide. BRP reserves the right to make warranty coverage contingent upon proof of proper maintenance.

BRP will not honor this limited warranty to any private use owner or commercial use owner if one of the preceding conditions has not been met. Such limitations are necessary to allow BRP to preserve both the safety of its products, and that of its consumers and the general public.

WHAT TO DO TO OBTAIN WARRANTY COVERAGE

The customer must cease using the Apache XC upon the appearance of an anomaly. The customer must notify an authorized Can-Am Off-Road vehicle dealer within three (3) days of the appearance of the defect in material or workmanship and present to the servicing authorized Can-Am dealer a proof of purchase (original invoice or bill of sale) of the new and unused Apache XC. All parts replaced under this limited warranty become the property of BRP.

WHAT BRP WILL DO

BRP's obligations under this warranty are limited to, at its sole discretion, repairing parts found defective under normal use, maintenance and service, or replacing such parts with new genuine BRP parts without charge for parts, at any authorized Can-Am dealer. BRP reserves the right to improve or modify products from time to time without assuming any obligation to modify products previously manufactured.

LIMITATIONS OF LIABILITY

THIS WARRANTY IS EXPRESSLY GIVEN AND ACCEPTED IN LIEU OF ANY AND ALL OTHER WARRANTIES, EXPRESSED OR IMPLIED, INCLUDING WITHOUT LIMITATION ANY WARRANTY OF MERCHANTABILITY OR FITNESS FOR A PARTICULAR PURPOSE. TO THE EXTENT THAT THEY CANNOT BE DISCLAIMED, THE IMPLIED WARRANTIES ARE LIMITED IN DURATION TO THE LIFE OF THE EXPRESS WARRANTY. INCIDENTAL AND CONSEQUENTIAL DAMAGES ARE EXCLUDED FROM COVERAGE UNDER THIS WARRANTY. SOME STATES/PROVINCES DO NOT ALLOW FOR THE DISCLAIMERS, LIMITATIONS AND EXCLUSIONS IDENTIFIED ABOVE, AS A RESULT, THEY MAY NOT APPLY TO YOU. THIS WARRANTY GIVES YOU SPECIFIC RIGHTS, AND YOU MAY ALSO HAVE OTHER LEGAL RIGHTS WHICH MAY VARY FROM STATE TO STATE, OR PROVINCE TO PROVINCE.

Neither the distributor, any BRP dealer nor any other person has been authorized to make any affirmation, representation or warranty regarding the product, other than those contained in this limited warranty, and if made, shall not be enforceable against BRP.

BRP reserves the right to modify this warranty at any time, being understood that such modification will not alter the warranty conditions applicable to the products sold while this warranty is in effect.

CONSUMER ASSISTANCE

In the event of a controversy or a dispute in connection with this limited warranty, BRP suggests that you try to resolve the issue at the dealership level. We recommend discussing the issue with the authorized dealer's service manager or owner.

If the matter still remains unresolved, contact BRP by filling out the customer contact form at www.brp.com or contact BRP by mail at one of the addresses listed under the *CONTACT US* section of this guide.

CUSTOMER INFORMATION

DATA PRIVACY INFORMATION

Bombardier Recreational Products inc., its affiliates and subsidiaries (“BRP”) is committed to protecting your privacy and support a general policy of openness about how we collect, use and disclose your personal information in the course of managing our relationship with you. **More details can be found by visiting BRP’s Privacy Policy at: <https://brp.com/en/privacy-policy.html> or by scanning the QR Code below.**

Please be assured that we have appropriate security measures in place to ensure that your personal information is protected against loss and unauthorized access.

Your personal information that may be collected by BRP, directly from you or from authorized dealers or authorized third parties, includes:

- **Contact, Demographic & Registration Information** (e.g., name, full address, phone number, email, gender, ownership history, language of communication)
- **Vehicle Information** (e.g., serial number, purchase and delivery date, unit usage, vehicle location and movements)
- **Third Party Information** (e.g., information received from BRP partners, joint-marketing activities information, social media)
- **Technological Information** (e.g., IP address, type of device, operating system, browser type, webpages you view, cookies and similar technologies when you use BRP or dealers’ websites or mobile application)
- **Interaction with BRP Information** (e.g., information collected when you call BRP’s in-house sales representatives, buy items on a BRP web Site, sign up for BRP emails, participate in BRP-sponsored contests and sweepstakes or attend BRP-sponsored events)
- **Transactional Information** (e.g., information necessary to handle returns, payment information when you purchase our products or services through our websites or mobile applications and other issues related to your purchase of BRP products)

This information may be used and processed for the following purposes:

- Safety & Security
- Customer Support for Sales & After Sales (e.g., complete or follow up with you about your purchase or maintenance)
- Registration & Warranty
- Communication (e.g., sending you a BRP satisfaction survey)
- Online Behavioural Advertising, Profiling and Location-Based Services (e.g., offer customized experience)
- Compliance & Dispute Resolution
- Marketing & Advertising
- Assistance (e.g., help with any delivery issues, handle returns, and other issues related to your purchase of BRP products).

We also may use personal information to generate aggregated or statistical data that no longer identifies you personally.

Your personal information may be disclosed to the following: BRP, BRP’s authorized dealerships, distributors, service providers, advertising & market research partners and other authorized third parties.

We may receive information about you from diverse sources, including third parties, such as BRP’s authorized dealerships and partners, with whom we offer

services or engage in joint-marketing activities. We may also receive information about you from social media platforms such as Facebook and Twitter, when you interact with us on those platforms.

Depending on the circumstances, your personal information may be communicated outside the region where you reside. Your personal information is retained only for as long as necessary for the purpose for which we obtained it and according to our retention policies.

To exercise your data privacy rights (e.g. right of access, right of rectification), to withdraw your consent in order to be removed from the address list for marketing purposes or for the satisfaction survey or for general data privacy questions, please contact BRP's Data Protection Officer at or by mail at **privacyofficer@brp.com** or by mail at:

BRP Legal Service, 726 St-Joseph, Valcourt, Quebec, Canada, J0E 2L0.

When BRP processes your personal information, they do so in compliance with its Privacy Policy available at: <https://www.brp.com/en/privacy-policy.html> or by using the following

QR Code.



CONTACT US

www.brp.com

Asia Pacific

BRP Asia

107D and 107E, 17/F, Tower 1,
Grand Century Place, Mongkok,
Kowloon, Hong Kong

Australia

Level 26
477 Pitt Street
Sydney, NSW 2020

China

上海市徐汇区衡山路10号6号楼301
Rm 301, Building 6,
No.10 Heng Shan Rd,
Shanghai, China

Japan

21F Shinagawa East One Tower
2-16-1 Konan, Minato-ku-ku,
Tokyo 108-0075

New Zealand

Suite 1.6, 2-8 Osborne Street,
Newmarket, Auckland 2013

Europe, Middle East and Africa

Belgium

Oktrooi plein 1
9000 Gent

Czech Republic

Stefanikova 43a
Prague 5
150 00

Germany

Itterpark 11
40724 Hilden

Finland

Isoaavantie 7
PL 8040
96101 Rovaniemi

France

Arteparc Bâtiment B
Route de la côte d'Azur,

13 590 Meyreuil

Norway

Ingvald Ystgaardsvei 15
N-7484 Trondheim
Salg, marketing, ettermarked

Sweden

Spinnvägen 15
903 61 Umeå
Sweden 90821

Switzerland

Avenue d'Ouchy 4-6
1006 Lausanne

Latin America

Brazil

Av. James Clerck Maxwell, 230
Campinas, Sao Paulo
CEP 13069-380

Mexico

Av. Ferrocarril 202
Parque Industrial Querétaro
Santo Rosa Jauregui, Querétaro
C.P. 76220

North America

Canada

3200A, rue King Ouest,
Suite 300
Sherbrooke (Québec) J1L 1C9

United States of America

10101 Science Drive
Sturtevant, Wisconsin
53177

CHANGE OF ADDRESS AND OWNERSHIP

If your address has changed or if you are the new owner of the Apache Track Kit, be sure to notify BRP by either:

- Notifying an authorized Can-Am dealer.
- **North America Only:** calling at 1 888 272-9222.
- Mailing one of the change of address cards on the following pages at one of the BRP addresses indicated in the *Contact Us* section of this guide.

In case of change of ownership, please join a proof that the former owner agreed to the transfer.

Notifying BRP, even after the expiration of the limited warranty, is very important as it enables BRP to reach the Apache Track Kit owner if necessary, like when safety recalls are initiated. It is the owner's responsibility to notify BRP.

STOLEN UNITS: If your personal Apache Track Kit is stolen, you should notify BRP or an authorized Can-Am dealer. We will ask you to provide your name, address, phone number, the Apache Track Kit identification number and the date it was stolen.

CHANGE OF ADDRESS <input type="checkbox"/>	CHANGE OF OWNERSHIP <input type="checkbox"/>	
TRACK KIT SERIAL NUMBER		
Model Number	Vehicle Identification Number (V.I.N.)	
OLD ADDRESS OR PREVIOUS OWNER:	NAME	
	NO.	STREET APT
	CITY	STATE/PROVINCE ZIP/POSTAL CODE
	COUNTRY	TELEPHONE
NEW ADDRESS OR NEW OWNER:	NAME	
	NO.	STREET APT
	CITY	STATE/PROVINCE ZIP/POSTAL CODE
	COUNTRY	TELEPHONE
	E-MAIL ADDRESS	

CHANGE OF ADDRESS <input type="checkbox"/>	CHANGE OF OWNERSHIP <input type="checkbox"/>	
TRACK KIT SERIAL NUMBER		
Model Number	Vehicle Identification Number (V.I.N.)	
OLD ADDRESS OR PREVIOUS OWNER:	NAME	
	NO.	STREET APT
	CITY	STATE/PROVINCE ZIP/POSTAL CODE
	COUNTRY	TELEPHONE
NEW ADDRESS OR NEW OWNER:	NAME	
	NO.	STREET APT
	CITY	STATE/PROVINCE ZIP/POSTAL CODE
	COUNTRY	TELEPHONE
	E-MAIL ADDRESS	

This page is
intentionally blank

This page is
intentionally blank

NOTE: _____

NOTE: _____

NOTE: _____

Model No. _____

VEHICLE

IDENTIFICATION NUMBER (V.I.N.) _____

ENGINE

IDENTIFICATION NUMBER (E.I.N.) _____

Owner: _____

NAME

No.

STREET

APT

CITY

STATE/PROVINCE

ZIP/POSTAL CODE

Purchase Date _____

YEAR

MONTH

DAY

Warranty Expiry Date _____

YEAR

MONTH

DAY

To be completed by the dealer at the time of the sale.

DEALER IMPRINT AREA

This page is intentionally blank

®TM and the BRP logo are trademarks of BOMBARDIER RECREATIONAL PRODUCTS INC. or its affiliates.

©2024 BOMBARDIER RECREATIONAL PRODUCTS INC. ALL RIGHTS RESERVED.

www.brp.com

ALUMACRAFT®

MANITOU®

SEA-DOO®

CAN-AM®

QUINTREX®

SKI-DOO®

LYNX®

ROTAX®

219002370