



MANITOU.

# OPERATOR'S GUIDE

P/N 3019-0003313  
REV. MAR. 2023

## **WARNING**

**Operating, servicing and maintaining a recreational marine vessel can expose you to chemicals including engine exhaust, carbon monoxide, phthalates, and lead, which are known to the State of California to cause cancer and birth defects or other reproductive harm. To minimize exposure, avoid breathing exhaust, service your vessel in a well-ventilated area and wear gloves or wash your hands frequently when servicing this vessel. For more information go to [www.P65warnings.ca.go/marine](http://www.P65warnings.ca.go/marine)**

Dear Manitou Owner,

You have likely spent a great deal of time researching your many choices in the boating market, and so we are especially honored by your selection. Because our boats are unequalled in both quality and style, you, like many other boaters, have chosen Manitou, and we would like to thank you for that choice.

In order to lengthen the life of your boat, proper use and care are required. Please take the time to review the information provided in this manual and in the accompanying National Marine Manufacturers Association (NMMA) Pontoon/Deck Style Boats Owner's Manual. You will find operating, cleaning, and maintenance tips, as well as guidance on boating safety and water rules. This information is vital to your own safety and that of your passengers. Please read it carefully.

At Manitou we take pride in building the safest pontoon boats in the industry. Please take the time to notice your boat's extra safety features. You will agree that your family's carefree boating experience is our top priority. You bought a pontoon boat for family fun, and Manitou's quality will give you the peace of mind to relax and enjoy your time spent boating for years to come.

Shortly after your warranty registration is received by the factory, you may receive a Manitou customer satisfaction survey. We want to hear from you! If you do not receive this survey, please contact Manitou by email at [manitou.consumers@brp.com](mailto:manitou.consumers@brp.com).

Thanks again for choosing Manitou.

**SECTION 1**  
**Important Safety Information..... 3**

**SECTION 2**  
**Introduction..... 4**  
 About This Manual..... 4  
 Before Your First Outing..... 4  
 Working Together ..... 5

**SECTION 3**  
**Ownership ..... 6**  
 Intended Use..... 6  
 Owner’s Packet ..... 6  
 Warranty Procedures.....7  
 Boat Identification .....7  
 State or Provincial Registration ..... 8  
 Insurance..... 8  
 Trash Disposal..... 8  
 Sanitary Waste Disposal ..... 8

**SECTION 4**  
**Safety..... 9**  
 Carbon monoxide ..... 9  
 Safe Boating Practices ..... 10  
 Safe Operation .....11  
 Swimming Safety.....12  
 Water Skiing Safety .....12  
 Safety Labels ..... 14  
 Required Safety Equipment..... 16  
 Other Safety Considerations .....17  
 Hazardous Conditions ..... 18  
 Compliance Labels ..... 19

**SECTION 5**  
**Operating your Manitou..... 23**  
 Fuel.....23  
 Fueling .....24  
 Launching Your Boat.....25  
 Boat Capacity Information.....26  
 Boarding .....26  
 Stowing Onboard Gear.....28  
 Weight Distribution .....28  
 Steering .....28  
 Navigation & Right-of-Way Rules .....29  
 Boat Speed.....29  
 Trimming.....29  
 Docking ..... 30  
 Loading and Trailering Your Boat..... 30  
 Boat Trailer Laws..... 31  
 Towing Capacity ..... 31  
 Tongue Weight..... 31  
 Trailer Hitch..... 31  
 Safety Chains.....32

Backing a Trailer with a Trailer .....32  
 Trailering Reminders.....32  
 Storing Your Boat..... 33  
 Blocking ..... 34

**SECTION 6**  
**Electrical Equipment ..... 35**  
 Electrical Wiring System ..... 35  
 Maximus DCM ..... 35  
 Batteries ..... 35  
 Lights ..... 36  
 Switches.....37  
 Instrument Panel .....37

**SECTION 7**  
**Controls.....41**  
 Steering System.....41  
 Autopilot.....42  
 Optional Joy Stick Steering ..... 43  
 Optional Dual Engine Controls ..... 43  
 Shift and Throttle Control System..... 44

**SECTION 8**  
**Other Components ..... 45**  
 Livewell..... 45  
 Sport Tower ..... 45  
 Swim Platform on Rotax Models..... 46  
 Stern Boarding Ladder..... 46

**SECTION 9**  
**Cleaning your Manitou..... 47**  
 Flooring.....47  
 Fabric Tops and Covers..... 48  
 Snaps and Zippers.....49  
 Vinyl-Coated Fabrics .....49  
 Exterior Surface & Graphics Care ..... 50

**SECTION 10**  
**Maintaining your Manitou .....51**  
 Corrosion..... 51  
 Aluminum Surfaces .....52  
 Battery and Electrical Care.....52

**SECTION 11**  
**Aquatic Invasive Species (AIS) .....53**

**SECTION 12**  
**Designated Seating Positions .....55**

**SECTION 13**  
**Index ..... 56**

**WARRANTY:**  
 Refer to the Warranty Guide for further information regarding warranty and CARB warranty specific to your boat.

# SECTION 1: IMPORTANT SAFETY NOTIFICATION

You must understand all of the safety statements shown on your boat and in this manual. Important safety-related information is highlighted in this manual using the designations shown below. You should understand all such designations prior to operating your Manitou.

## **DANGER**

Indicates an imminently hazardous situation which, if not avoided, will result in death or serious injury or substantial property damage.

## **WARNING**

Indicates a potentially hazardous situation which, if not avoided, could result in death or serious injury or property damage.

## **CAUTION**

Indicates a potentially hazardous situation which, if not avoided, may result in minor or moderate injury or property damage.

## **CAUTION**

Used without the safety alert symbol indicates a potentially hazardous situation which, if not avoided, may result in property damage.

## **NOTICE**

Notice indicates installation, operation, or maintenance information which is important but not hazard-related.

You are likely to encounter a variety of situations beyond those listed in this manual that require safe practices. Be ready, and make safety a first priority at all times!

# SECTION 2: INTRODUCTION

Congratulations! As the owner of a Manitou pontoon boat, you can look forward to enjoying the water with family and friends for years to come. Not only have you purchased the highest quality pontoon boat on the market, but you have also bought the peace of mind that comes from knowing that Manitou stands behind each and every boat it sells. Should you encounter a problem, Manitou will work with your dealer to fix it quickly, so that you can get back to boating.

## ABOUT THIS MANUAL

This manual is part of your boat's equipment, and provides information for basic boating excursions. Make sure to have it on board at all times.

Remember that all boaters are responsible for their own safety and the safety of the people around them. Even though you may be an experienced boater, you can still learn from this manual. Note, however, that this manual does not change or alter any of the manufacturer's specifications, operations, or maintenance manuals. It is a reference guide to help you make the most of your boating experience.

## BEFORE YOUR FIRST OUTING

Before you take your Manitou out on the water for its maiden voyage, please take the time to get to know your new boat. Start with the following steps:

- Take a look through your owner's packet and become familiar with the information found there.
- Read this manual, taking special note of safety warnings and other critical information.
- Familiarize yourself with the safety labels throughout your boat. Understand their meaning, and be ready to point them out to passengers.
- Review the NMMA *Pontoon/Deck Style Boats Owner's Manual*, included in your owner's packet.
- Require any other individual who may be operating your boat to read and review this manual and all materials in your owner's packet.

Next, before you take your Manitou out for the first time; become familiar with the boat itself. The following steps are very important:

- Sit in the captain's chair and make sure you know what buttons and switches control various features.
- Familiarize yourself with how to read each gauge on your boat's control panel.
- Take note of your boat's width and length.
- Ensure that any other individual who may be operating your boat has also completed these steps.

Finally, remember that you are responsible at all times for ensuring the safety of your boat's passengers and that of other waterway users. Practice courteous and responsible boating each time you enjoy your Manitou!

## WORKING TOGETHER

Successful boat ownership is built on teamwork. The manufacturer, dealer, and boat owner each have a role to play in the goal of ensuring the best possible on-the-water experience for years to come. Each role carries its own responsibilities, which can be described as follows.

### **MANUFACTURER'S ROLE**

We hold ourselves to rigorous manufacturing standards throughout the process of building each Manitou. To ensure the highest quality, we perform rigorous inspections and testing.

### **DEALER'S ROLE**

Your dealer has a responsibility to inspect and approve your Manitou before delivery. Upon completion of the sale of a Manitou boat to you, your dealer should also complete the following steps:

- Register your boat with Manitou.
- Ensure your understanding of important precautions required for the safe use of your Manitou.
- Provide you with an orientation to the general operation of your Manitou.
- Furnish you with a complete owner's packet that includes all of the manuals and information regarding your new Manitou and any other components related to your purchase.

### **OWNER'S ROLE**

Owner responsibilities include, but are not limited to, the following:

- Examine the boat and confirm that all systems are working properly before you accept delivery.
- Review in detail all manuals, literature, and instructions enclosed in the owner's packet, and use all equipment in accordance with those instructions.
- Read and understand the Manitou limited product warranty.
- Operate all equipment in accordance with the manufacturer's instructions.
- Render proper maintenance and periodic servicing to the boat, motor, and components in accordance with the manufacturer's requirements and recommendations.
- Clean and maintain your boat on a regular schedule.
- Learn and obey all local, state, provincial, and federal laws pertaining to the use and transport of your boat.
- Insure your boat.
- Complete and pass a boating safety course.
- Read and obey all safety labels on your boat.
- Make safety your first priority at all times.

# SECTION 3: OWNERSHIP

## INTENDED USE

Pontoon boats are designed for boating on inland waterways, rivers, lakes, and bays only. It is important to understand that dangerous situations that can arise from the misuse of your Manitou.

Dangerous situations include those in which swells and high waves may damage your pontoon, cause an operator to lose control of the boat, and put passengers in harm's way. As such, all Great Lakes and ocean use should be strictly avoided.

### **WARNING**

**High waves coming over the bow of your Manitou are dangerous and may damage or dent wall skins.**

### **WARNING**

**Do not use your Manitou to pull a parasail, kite, glider, or any other device that may become airborne.**

## OWNER'S PACKET

Your owner's packet provides a variety of useful information sources. It includes the following:

- This owner's manual, including warranty information.
- *Pontoon/Deck Style Boats Owner's Manual*, a publication of the National Marine Manufacturers Association (NMMA).
- Critical safety information from the United States Coast Guard (USCG) and NMMA.
- Care and cleaning information for your boat's surfaces and materials.
- Manuals and information about the operation of your Manitou.
- Seating Positions Document

Your boat dealer may also include information about other components in the owner's packet.

In sum, the materials in your owner's packet provide operation, service, specifications, maintenance, warranty, and other helpful information. It is important to read and understand all of the material contained in your owner's packet prior to operating your boat.



# WARRANTY PROCEDURES

Please read the Manitou warranty coverage so that you know what is covered under its terms.

You are required to obtain warranty work through an authorized Manitou dealer, preferably the dealer from which you purchased your Manitou. The dealer is your first contact for warranty issues, and will be best suited to respond to any issues that may arise with your pontoon boat.

## BOAT IDENTIFICATION

A permanent record of your boat is maintained by Manitou Pontoon Boats. Tracked using your boat's Hull Identification Number (HIN), this record includes information on your boat's equipment and accessories, the name of the dealership from which you purchased it, and the date it was shipped.

The HIN tag is attached to the riser on the starboard side of the boat near the stern. The HIN should also be listed on your registration.

To ensure a quick response when you contact your dealer regarding warranty or other work for your Manitou, please provide the HIN, the model length, and the color of your boat. Not providing this information may unnecessarily delay the claims process. For your future convenience, we suggest that you note this information in the following table.



HIN
Model
Length
Color

## STATE OR PROVINCIAL REGISTRATION

All watercraft must display registration numbers on the starboard and port sides of the vessel. Your boat must be registered in its main state or province of usage. Registration numbers and validation stickers must be displayed according to your state or provincial laws and regulations.

## INSURANCE

As a boat owner, you are legally responsible for any damages or injuries caused by your boat. In the majority of states and provinces, this holds true even if a person other than the owner is operating the boat when an accident occurs. Just as you do for your home and automobile, you should carry adequate personal liability and property damage insurance on your boat. Protect your investment by also insuring your boat, motor, and trailer against physical damage or theft. Contact your insurance agent for coverage information.

## TRASH DISPOSAL

It is important to act responsibly to keep our lakes and waterways clean. Plastic refuse dumped in the water is known to kill fish and other marine wildlife, and may also cause damage to boat propellers and water intakes. Some forms of waterborne garbage litter beaches and cause infection and illness. USCG regulations prohibit the dumping of plastic refuse or other garbage mixed with plastics anywhere in the water. Dumping of other forms of trash in the water within specified distances from shore is also prohibited.

## SANITARY WASTE DISPOSAL

You are responsible for obeying all local laws concerning sanitary waste disposal. If your boat has a marine toilet or other sanitary device, contact the USCG, local marina, or your dealer for information regarding proper disposal of sanitary waste. Under no circumstances should such waste be dumped into the water.

**It is illegal for any vessel to dump plastic ANYWHERE in the ocean or navigable waters of the United States. Annex V of MARPOL TREATY is an International Law for a cleaner, safer marine environment. Violation of those requirements is a Class D felony and may result in a civil penalty, up to a \$25,000 fine and imprisonment.**



U.S. lakes, rivers, bays or sounds and 3 miles from shore

**ILLEGAL TO DUMP:**

**Plastic and Garbage**

- Paper
- Rags
- Glass
- Food
- Metal
- Crockery
- Dunnage



3 to 12 miles

**ILLEGAL TO DUMP:**

- Plastic
- Dunnage, lining and packing materials that float; also if not ground to less than one inch
- Paper
- Rags
- Glass
- Metal
- Crockery
- Food



12 to 25 miles

**ILLEGAL TO DUMP:**

- Plastic
- Dunnage, lining and packing materials that float



Outside 25 miles

**ILLEGAL TO DUMP:**

- Plastic

**Regional state and local regulations may further restrict the disposal of garbage. The discharge of all garbage into the Great Lakes or their connecting tributary waters is prohibited.**



## SECTION 4: SAFETY

As the owner of the boat, it is your responsibility to be a safe boater, to follow and enforce safety rules, to know and adhere to the rules of the water, and to use common sense at all times. It is important that anyone to whom you entrust your boat also understands these responsibilities.

Make sure you understand each of the safety warnings found on your boat and commit to following the safe boating recommendations found in this section.

Then, before you embark on any outing, check that all safety equipment is on board and in working condition. This includes one wearable personal flotation device (PFD) for each person on board, and all other USCG-required safety equipment. Confirm that each passenger aboard the boat is aware of the location of these items. Learn more about these safety requirements, as well as additional boat safety information at the USCG website; [www.uscgboating.org](http://www.uscgboating.org).

### CARBON MONOXIDE

Exhaust fumes contain carbon monoxide (CO), which is an odorless and colorless gas. Carbon monoxide is toxic and can be fatal if breathed over an extended period of time. Symptoms of CO inhalation include, but are not limited to, dizziness, nausea, headache, sleepiness, vomiting, throbbing in the temples, muscular twitching, and an inability to think clearly. If these symptoms are present and persist in you or another individual, seek urgent medical attention.

On your boat, carbon monoxide in engine exhaust can accumulate within enclosed areas during operation at slow speeds or when stopped in the water. Using the rear enclosure while the boat is underway increases the risk of CO accumulation in your boat, and the presence of a tail wind can increase accumulation. Provide adequate ventilation at all times, and increase speed as needed.

#### DANGER

**Carbon monoxide can be harmful or fatal if inhaled. Keep exhaust outlets clear of blockage, away from open windows. Provide adequate ventilation at all times.**

## SAFE BOATING PRACTICES

Boating safety is a serious issue. You are responsible for your own safety, the safety of your passengers, and the safety of fellow waterway users. The following are some basic safe boating recommendations that must be observed:

- Never operate the boat, or allow others to operate the boat, while under the influence of drugs or alcohol. This is a federal offense and can carry a significant penalty.
- Keep your boat and its equipment in a safe and usable condition. Regularly inspect the boat, engine, and safety equipment for any signs of damage or disrepair.
- Ensure that a throwable flotation device and a fire extinguisher are on your boat at all times. This equipment must meet regulation standards, be easily accessed, and be maintained in working condition.
- Check weather and water conditions before launching. Be prepared for sudden changes in the boating environment, and for cooler or warmer conditions than originally anticipated.
- In case of an emergency involving the primary operator, confirm that at least one other person on board the boat knows the basic and safe operations of the boat.
- Never allow an inexperienced person to operate your boat.
- Become familiar with local, state, and provincial boating laws and regulations. Observe them at all times.
- It is strongly recommended that you complete and pass a boating safety class.

### **WARNING**

**Intoxication and boating do NOT mix! Never operate your boat while under the influence of alcohol or drugs.**

### **WARNING**

**Read, follow, and understand all safety labels on your boat.**

## SAFE OPERATION

“Safe operation” means that neither you nor your passengers misuse the boat, but instead make a practice of applying good judgment at all times. In addition to any applicable safety laws, recommendations, or procedures, establish the habit of following general safe-operation guidelines:

- Load your boat according to the limits set on the capacity tag. Do not overload your boat. Evenly distribute the load from bow to stern, and ensure that the weight on your boat is evenly distributed at all times. Reduce the load if weather conditions include high winds, rough seas, fog, storm warnings, or small craft advisories.
- Direct all passengers to remain seated while the boat is under power. While the boat is moving, boat passengers should remain clear of any areas that are not designated for seating, including the bow, transom, railings, sundeck pad, and furniture backrests. If a swivel fishing seat is present on your boat, it should not be used for seating if the boat is traveling faster than five miles per hour.

### **WARNING**

**Do not sit on the bow of the boat while it is under power.**

- Keep all boat gates closed while the boat is under power in order to prevent falls overboard and injuries.
- Maintain your speed at or below the posted speed limit. Avoid excessive speeds, especially close to shore.
- Learn and follow the rules of navigation. Ensure that all boat drivers are familiar with these rules.
- Know the maximum horsepower capacity rating on the certification plate of your motor and do not exceed it. Exceeding the horsepower capacity of your boat and motor can lead to serious conditions that may result in accidents or injuries.
- Become familiar with the length of time it takes to stop your boat from various speed levels. Remember that, unlike a car, a boat does not have brakes.
- Confirm that the engine is off and the propeller is completely stopped before allowing anyone to enter the water or re-board from the water.
- Use a boat hook or other suitable device to protect your boat while docking. Never use your hands or feet to control your boat’s movement toward the dock. Your boat’s weight and forward momentum could cause serious injury to a limb that becomes caught between the boat and a dock.

### **WARNING**

**Never exceed the maximum horsepower or weight capacity of your boat.**

## SWIMMING SAFETY

When swimming from your boat, the following basic safe swimming recommendations must be observed:

- Anchor the boat and shut off the motor before anyone enters the water.
- Swim in the presence of others. Never swim alone.
- Swim on the shore side of the boat, away from other boat traffic.
- Designate a person on the boat to observe swimmers at all times.
- Use the ladder to enter the water for your safety. Unknown water depths and other variables make ladder entry the safest method.
- Use a ladder or other safe means of reboarding.
- Swimmers must not use the pontoon tubes to enter or leave the water.

### **WARNING**

**Never allow swimmers or water skiers to enter or exit the boat with the engine running or the propeller moving. Never back up your boat to reach a person in the water.**

### **WARNING**

**Never dive from any part of the boat. Water depths can be unpredictable, and serious injuries or death can occur from diving into shallow water.**

### **WARNING**

**Children must be under adult supervision at all times, both in the water and on the boat.**

### **WARNING**

**Swimming can be hazardous. Follow all safety rules.**

## WATER SKIING SAFETY

Water skiing poses several hazards in addition to those discussed under the "Swimming Safety" section. The following basic safe water skiing rules must be observed.

- The ski tow bar is rated for a maximum of 300 pounds (136kg). Do not pull multiple towables; pull only one towable at a time.
- Start the engine only when the skier is a safe distance from the boat.
- Accelerate the boat slowly forward until the rope is taut.
- Before applying the throttle, check for traffic ahead.
- Follow the skier's signals to set the optimum speed for the skier.
- Designate a passenger, other than the boat's driver, to act as spotter. The spotter should watch the skier and inform the driver when the skier is down.
- When the skier goes down, look for his or her "OK" signal.
- Approach the downed skier on the starboard side only. Stop the motor once you are close.
- Always be aware of shallow water and obstructions.
- Do not ski after dark.
- Do not ski near swimmers or in crowded boat traffic. Keep away from fishermen.

### WARNING

**Keep a downed skier in sight at all times.**

### CAUTION

**Designate a passenger to act as a spotter. The driver must not also act as a spotter.**

### WARNING



**All water skiers are required to wear a USCG approved PFD at all times.**

For more information on water skiing safety, visit [www.boatus.org](http://www.boatus.org).



# SAFETY LABELS

The safety labels present on your Manitou serve as reminders of important safety considerations. Following are the labels commonly found on Manitou boats. Note their locations on your own boat, read them carefully, and follow their directives. Ask passengers to do the same.

<b>⚠ DANGER</b>	
<ul style="list-style-type: none"> <li>• <b>CONTACT WITH A SPINNING PROPELLER WILL CAUSE SERIOUS INJURY OR DEATH.</b></li> <li>• <b>SHUT OFF ENGINES</b> while people are in the water near the boat, on the swim platform, or on the boarding ladder.</li> <li>• <b>NEVER OPERATE IN REVERSE TOWARD A PERSON</b> in the water.</li> </ul>	

<b>⚠ DANGER</b>		
	<p><b>CONTACT WITH A SPINNING PROPELLER WILL CAUSE SERIOUS INJURY OR DEATH.</b></p> <p><b>STAY CLEAR OF BOAT AND STAY OFF SWIM PLATFORM AND BOARDING LADDER WHILE ENGINE IS RUNNING.</b></p>	
		<p><b>CARBON MONOXIDE (CO) CAN CAUSE BRAIN DAMAGE OR DEATH.</b></p> <ul style="list-style-type: none"> <li>• Engine and generator exhaust contains odorless and colorless carbon monoxide gas.</li> <li>• Carbon monoxide will be around the back of the boat when engines or generators are running.</li> </ul> <p><b>MOVE TO FRESH AIR</b> if you feel nausea, headache, dizziness, or drowsiness.</p>

<b>⚠ DANGER</b>	
	<p><b>CONTACT WITH A SPINNING PROPELLER WILL CAUSE SERIOUS INJURY OR DEATH.</b></p> <p><b>STAY CLEAR OF BOAT AND STAY OFF SWIM PLATFORM AND BOARDING LADDER WHILE ENGINE IS RUNNING.</b></p>

<b>⚠ WARNING</b>		
<b>Failure to follow these warnings could cause SEVERE INJURY or DEATH.</b>		
<ul style="list-style-type: none"> <li>• <b>CARBON MONOXIDE (CO) CAN CAUSE BRAIN DAMAGE OR DEATH.</b> <ul style="list-style-type: none"> <li>- Engine and generator exhaust contains odorless and colorless carbon monoxide gas.</li> <li>- Signs of carbon monoxide poisoning include nausea, headache, dizziness, drowsiness, and lack of consciousness.</li> <li>- <b>MOVE TO FRESH AIR</b> if anyone shows signs of carbon monoxide poisoning.</li> <li>- See Operator's Guide for additional information regarding carbon monoxide poisoning.</li> </ul> </li> <li>• <b>CHECK WEATHER FORECAST BEFORE LEAVING DOCK</b> and heed all weather advisories</li> <li>• <b>WEAR SAFETY LANYARD</b> at all times when operating boat to prevent unmanned boat operation.</li> <li>• <b>NEVER OPERATE WHILE UNDER THE INFLUENCE</b> of drugs or alcohol.</li> <li>• <b>DO NOT OVERLOAD THE BOAT. ENSURE THE WEIGHT IS PROPERLY AND EVENLY DISTRIBUTED</b> fore and aft and on both sides of the boat to avoid poor handling, sudden loss of control, swamping and/or capsizing.</li> </ul>		<ul style="list-style-type: none"> <li>• <b>PASSENGERS SHOULD WEAR U.S. COAST GUARD APPROVED LIFE JACKETS.</b></li> <li>• <b>MAKE SURE THAT ALL PASSENGERS ARE PROPERLY SEATED WHILE UNDERWAY.</b> To avoid passengers falling overboard or being ejected from the boat, do not allow passengers to sit on seat backs, gunwales, or outmost deck edges while boat is moving.</li> <li>• <b>REDUCE SPEED BEFORE ATTEMPTING SUDDEN OR SHARP TURNS, AND MAINTAIN SAFE SPEEDS</b> for water conditions and environment at all times. Maneuverability at high speed is limited, and sudden turns may cause loss of boat control.</li> <li>• <b>KEEP PROPER LOOKOUT AND SAFE DISTANCE</b> for the conditions at all times to avoid collisions.</li> <li>• <b>OBEY APPLICABLE NAVIGATION RULES AND BOATING LAWS.</b></li> <li>• <b>USE CAUTION AND PROPER LIGHTING</b> during nighttime boating and boating in adverse weather.</li> <li>• <b>READ THE OPERATOR'S GUIDE AND COMPLETE THE BOATER'S PRE-OPERATION CHECKLIST</b> prior to boat operation.</li> </ul>
		

<b>⚠ WARNING</b>	<b>⚠ MISE EN GARDE</b>
<p>NO VENTILATION IS PROVIDED. FUEL VAPORS ARE A FIRE AND EXPLOSION HAZARD. TO AVOID INJURY OR DEATH, DO NOT STORE FUEL OR FLAMMABLE LIQUIDS HERE.</p>	<p>NE PAS ENTREPOSER DE RÉSERVOIR À ESSENCE DANS CET ESPACE.</p>



## ⚠ WARNING





DO NOT OVERLOAD THE BOW AS THIS MAY CAUSE POOR HANDLING OR NOSEDIVING. DISTRIBUTE PASSENGERS EVENLY AND RESPECT APPROPRIATE SEATING POSITIONS WHILE UNDERWAY.

AVOID PERSONAL INJURY OR DEATH FROM FALLING OVER THE BOW. DO NOT SIT ON OR HANG LEGS OVER THE FORWARD END OF DECK. IF PRESENT, DO NOT OCCUPY FORWARD PEDESTAL SEATS WHILE UNDERWAY.

## ⚠ WARNING

AVOID SERIOUS INJURY OR DEATH FROM FIRE OR EXPLOSION RESULTING FROM LEAKING FUEL. INSPECT SYSTEM FOR LEAKS FREQUENTLY.

CONTENTS CAN BE UNDER PRESSURE. AVOID SERIOUS INJURY OR DEATH FROM FIRE OR EXPLOSION. OPEN SLOWLY IN WELL VENTILATED AREA. NO SMOKING OR OPEN FLAMES.

USE ONLY GASOLINE UP TO E10 (MAXIMUM 10% OF ETHANOL CONTENT)   

NEVER USE GASOLINE WITH ETHANOL CONTENT HIGHER THAN 10%.

THE USE OF GASOLINE WITH ETHANOL CONTENT HIGHER THAN 10% CAN DAMAGE THE ENGINE AND THE FUEL SYSTEM AND WILL VOID THE MANUFACTURER'S WARRANTY.

## ⚠ WARNING

AVOID SERIOUS INJURY OR DEATH FROM FIRE, EXPLOSION OR ELECTRICAL SHOCK.

- The power supply for this device must be connected to a Ground Fault Circuit Interrupt (GFCI) protected outlet.
- When using an extension cord, connect the AC charger plug before connecting to the GFCI protected AC outlet.
- Make connection in an open atmosphere free of explosive fumes.
- Make connection in a secure manner that will avoid contact with the water.
- Do not operate this charger if submerged in water.

## ⚠ MISE EN GARDE

DANGER DE BLESSURE GRAVE OU DE MORT RÉSULTANT D'UNE EXPLOSION OU D'UN INCENDIE PROVOQUÉ PAR UNE FUITE DE CARBURANT. INSPECTER LE SYSTÈME RÉGULIÈREMENT POUR S'ASSURER QU'IL N'Y A AUCUNE FUITE.

## ⚠ WARNING



**PINCH POINT.**  
Keep hands and fingers clear.

## ⚠ WARNING

### PROPELLER INJURY HAZARD

ONLY ENTER WATER WITH THE CAPTAIN'S PERMISSION  
Failure to adhere to this warning may result in severe bodily injury and/or death.



- **PROPELLERS TURN AUTOMATICALLY**  
This could injure someone in the water
- The boat will move suddenly in any direction
- It is NOT SAFE to be in the water near the boat
- DO NOT enter the water or position yourself where you could fall into the water due to sudden boat movement

## ⚠ WARNING

TOP SHOULD NOT BE USED WHEN VESSEL SPEED EXCEEDS 45 MPH. NEVER TOW/TRAILER BOAT WITH THE TOP OPEN OR TOP ACCESSORIES IN USE.

## ⚠ WARNING

AVOID INJURY OR DEATH FROM FALLING OVERBOARD. CLOSE AND LATCH THE DOOR BEFORE GETTING UNDERWAY. STAY INSIDE GATES AND RAILS AND REMAIN SEATED WHILE UNDERWAY.

## REQUIRED SAFETY EQUIPMENT

As a boat owner, you are responsible for supplying all legally required safety equipment. Contact USCG for details pertaining to required safety equipment, and consult local, state, and provincial authorities for any additional applicable laws and regulations. For your convenience, the following lists provide the minimum requirements for onboard safety equipment.

### REQUIRED ONBOARD SAFETY EQUIPMENT

- Fire Extinguisher
- Visual Distress Signal
- Navigation Lights
- Horn
- Throwable Flotation Device
- One PFD per Person on Board

### RECOMMENDED ONBOARD SAFETY EQUIPMENT

- Anchor and Anchor Line
- Tow Line
- Dock Fenders
- Boat Hook/warm Clothing
- Oar or Paddle
- Compass
- VHF Radio
- Flashlight
- First Aid Kit
- Sunscreen Lotion
- Warm Clothing
- Rain Gear
- Extra Food
- Extra Water

## CAUTION

**When on, in, or near water, ensure that children wear PFDs at all times.**

## OTHER SAFETY CONSIDERATIONS

### FUEL SYSTEM SAFETY

When fueling your Manitou, it is important to be aware that gasoline can pose a health and safety hazard. Gasoline is highly flammable, and mishandling it can result in injury or death. Always observe all posted safety warnings while fueling your boat, including no smoking requirements.

#### **⚠ WARNING**

**Always turn off the engine while fueling your boat.**

#### **⚠ WARNING**

**Never smoke while fueling your boat.**

#### **⚠ WARNING**

**Gasoline vapors are highly explosive. To prevent a possible explosion and fire, check for fumes or an accumulation of fuel before starting the engine.**

### STOP SWITCH LANYARD

The stop switch lanyard is a safety device designed to automatically stop the engine when the lanyard is detached from the binnacle control. When your boat is under power, the lanyard clip should be attached to the driver's clothing, leg, or arm. If the driver moves away from the binnacle control, the power will be cut, preventing your boat from running without a driver present at the controls.

**Note:** The stop switch lanyard on your boat may differ from the one shown here.

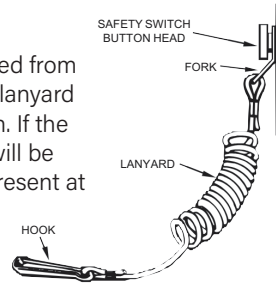

#### **⚠ WARNING**

**The stop switch lanyard must not be removed or modified. It must always be kept clear of any obstruction that could interfere with its operation.**

#### **⚠ WARNING**

**The driver should always attach the stop switch lanyard clip to his or her clothing, leg, or arm when the engine is running.**

**United States Federal Law requires the use of stop switch lanyards**

## HAZARDOUS CONDITIONS

Changing conditions on any body of water can present a unique danger to you and your boat. Hazards such as underwater stumps, unexpected sandbars, or shallow water should be avoided. If you are unfamiliar with the waters, discuss potential hazards with other boaters who are familiar with the area. Then proceed with caution.

Always check the weather before boating, and postpone your trip if hazardous weather conditions are predicted. While on your boat, continue to check the weather periodically.

Manitou is not responsible for any damage or personal injury that may occur while using your boat in hazardous boating conditions, including, but not limited to, damage caused by stumps, sandbars, shallow waters, wave swells, and similar conditions.

### **WARNING**

**If you should damage your boat because of any hazardous condition, take your boat to a qualified Manitou dealer and have it inspected. Do not continue to use your boat until it has been inspected.**

## COMPLIANCE LABELS







Several compliance labels are affixed to the vessel to demonstrate compliance with Federal boating and/or emissions standards. These labels may include the United States Coast Guard Capacity Plate, Canadian Compliance Notice, California Air Resources Board Certification Label, United States Environmental Protection Agency Compliance Statement, the European Union CE mark, and the United Kingdom UKCA compliance mark. These various labels are affixed to the boat, as applicable, and must not be altered or modified in any way. Federal laws require these labels to remain installed on the vessel. If these applicable labels are damaged, they must be replaced immediately by contacting your local Manitou dealer.

### Example of Capacity Plate



The United States Coast Guard capacity plate lists the maximum approved number of persons, maximum weight, and maximum horsepower for a given vessel. Under the U.S. Coast Guard Federal Boat Safety Act of 1971, boats less than 20 feet powered with an inboard, outboard, or stern drive engine manufactured after November 1, 1972, must display a capacity plate defining the safe load limits. This plate must be mounted where you can see it when preparing to get underway. The capacity plate is located on the starboard side captain's station to the right of the steering wheel. Capacity plates should never be removed, altered, or tampered with. Many states have statutes prohibiting the carriage of people and gear in excess of the stated capacity or the installation of a motor that exceeds the recommended horsepower limit. Additionally, you may void your insurance policy if you are found to have exceeded the limits stated on your capacity plate.

**Example of Canadian Compliance Notice for Boats Less than 6 Meters (only applicable to boats sold in Canada)**

CANADIAN COMPLIANCE NOTICE AVIS DE CONFORMITÉ CANADIEN		
MAXIMUM RECOMMENDED SAFE LIMITS LIMITES MAXIMALES DE SÉCURITÉ RECOMMANDÉES		
	<b>7</b>	<b>552 kg 1216 lbs/lb</b>
	+	
	+	<b>1033 kg 2278 lbs/lb</b>
	<b>45 kW</b>	<b>228 kg</b>
	<b>60 HP</b>	<b>503 lbs/lb</b>
THE MAXIMUM RECOMMENDED SAFE LIMITS MIGHT HAVE TO BE REDUCED IN ADVERSE SEA AND WEATHER CONDITIONS. LES LIMITES MAXIMALES DE SÉCURITÉ RECOMMANDÉES PEUVENT DEVOIR ÊTRE RÉDUITES DANS LES CONDITIONS DE MER ET DES CONDITIONS MÉTÉOROLOGIQUES DIFFICILES.		
TRITON IND. INC. (TII) LANSING, MICHIGAN, USA		
MODEL / MODÈLE: AB 1825		
THE MANUFACTURER DECLARES THAT THIS VESSEL COMPLIES WITH THE PLEASURE CRAFT CONSTRUCTION REQUIREMENTS OF THE SMALL VESSEL REGULATIONS, AS THEY READ ON THE DAY ON WHICH THE CONSTRUCTION OF THE VESSEL WAS STARTED OR ON THE DAY ON WHICH THE VESSEL WAS IMPORTED. LE FABRICANT ATTESTE QUE CE BÂTIMENT EST CONFORME AUX ENGINCES DE CONSTRUCTION DES EMBARCATIONS DE PLAISANCE DU RÈGLEMENT SUR LES PETITS BÂTIMENTS, EN VIGUEUR À LA DATE DU DÉBUT DE SA CONSTRUCTION OU À LA DATE DE SON IMPORTATION.		

**Example of Canadian Compliance Notice for Boats Greater than 6 Meters (only applicable to boats sold in Canada)**

CANADIAN COMPLIANCE NOTICE AVIS DE CONFORMITÉ CANADIEN	
TRITON IND. INC. (TII) LANSING, MICHIGAN, USA	
MODEL / MODÈLE: 22 Oasis Angler VP II	
THE MANUFACTURER DECLARES THAT THIS VESSEL COMPLIES WITH THE PLEASURE CRAFT CONSTRUCTION REQUIREMENTS OF THE SMALL VESSEL REGULATIONS, AS THEY READ ON THE DAY ON WHICH THE CONSTRUCTION OF THE VESSEL WAS STARTED OR ON THE DAY ON WHICH THE VESSEL WAS IMPORTED. LE FABRICANT ATTESTE QUE CE BÂTIMENT EST CONFORME AUX ENGINCES DE CONSTRUCTION DES EMBARCATIONS DE PLAISANCE DU RÈGLEMENT SUR LES PETITS BÂTIMENTS, EN VIGUEUR À LA DATE DU DÉBUT DE SA CONSTRUCTION OU À LA DATE DE SON IMPORTATION.	

The Canadian Compliance Notice is a statement from the manufacturer or importer that a vessel is built according to the construction requirements of the Small Vessel Regulations. The Small Vessel Regulations require, with a few exceptions, all pleasure craft of less than 24 meters, and as of April 29, 2011, all non-pleasure vessels of not more than 15 gross tonnage, that are or can be fitted with engine(s) to have a Compliance Notice affixed to them in a conspicuous position plainly visible from the helm. By law, the Compliance Notice must be permanently affixed to the pleasure craft.

**California Air Resources Board (CARB) Emission Control System Information Label (only applicable to boats sold in California)**

EMISSION CONTROL SYSTEM INFORMATION

MEETS 2022 MY CALIFORNIA EVAP EMISSIONS REGULATIONS FOR  
SPARK-IGNITION MARINE WATERCRAFT

MANUFACTURER: TRITON INDUSTRIES

CALIFORNIA EVAP FAMILY: NTTIPVSSL111

EMISSIONS CONTROL SYSTEM: SO 32-MY22CAL18-24

## California Proposition 65 Hangtag

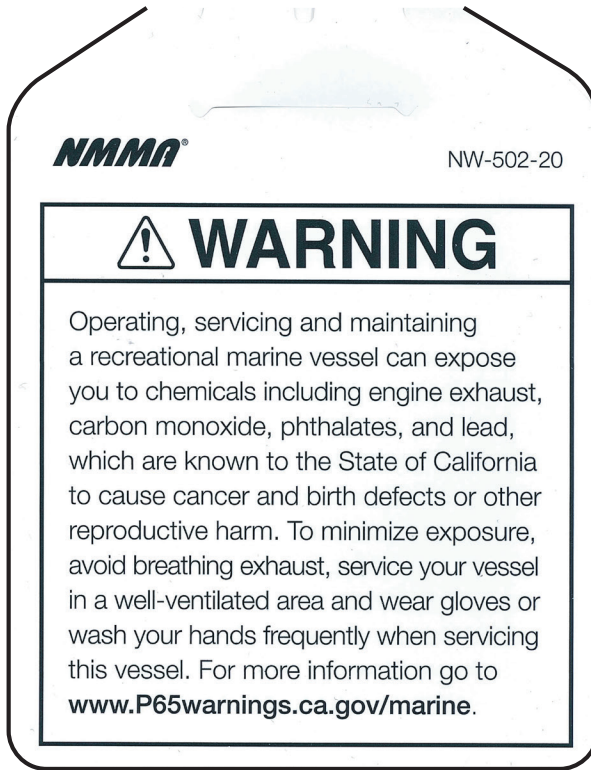

The California Proposition 65 also known as the Safe Drinking Water and Toxic Enforcement Act of 1986 requires a variety of specific consumer warnings to be placed on products to notify consumers of potential exposure to certain chemicals the State of California identifies as cancer-causing or causing reproductive harm. Any vessels sold in the state of California are required to display a proposition 65 hangtag with specific boat related information for consumers.

The Spark-Ignition Marine Engine and Watercraft regulations cover any spark-ignited engine that is used to propel a marine watercraft, including personal watercraft, outboard engines, and sterndrive/inboard (e.g. propeller driven vessels, jet boats, air boats, hovercraft) engines. The California Emission Control System Information label provides compliance information regarding evaporative emissions from the vessel's fuel system. The label includes the evaporative family name, model year, manufacturer, and the emissions control system type. This label is required for any new boat offered for sale in the state of California.

**European Union CE Certification Mark and United Kingdom (UKCA) Compliance Mark (Only applicable to boats sold into the European Union or United Kingdom)**



The letters 'CE' appear on many products traded on the extended Single Market in the European Economic Area (EEA). They signify that products sold in the EEA have been assessed to meet high safety, health, and environmental protection requirements. By affixing the CE marking to a product, a manufacturer declares that the product meets all the legal requirements for CE marking and can be sold throughout the EEA. This also applies to products made in other countries that are sold in the EEA. The United Kingdom Conformity Assessment (UKCA) mark is a new UK product marking that will be required for certain goods sold in Great Britain (England, Wales, and Scotland). It applies to most goods that previously required the CE mark.



# SECTION 5: OPERATING YOUR MANITOU

To make the most of your Manitou boating experience, it is important to get to know your boat. In this section you will find practical steps and specific actions needed to operate your boat for maximum enjoyment. Please read and make a habit of using this information

## FUEL

Fuel blending varies by country and region. Your boat has been designed to operate using the recommended fuels; however, be aware of the following:

- Alcohol blended fuels attract and hold moisture which may lead to fuel phase separation and can result in engine performance problems or engine damage.
- Use of fuel containing alcohol above the percentage specified by government regulation can result in the following problems in outboard engines and fuel system components:
  - Vapor lock or fuel starvation
  - Starting and operating difficulties
  - Deterioration of rubber or plastic parts
  - Corrosion of metal parts
  - Damage to internal engine parts

Have your dealer inspect for fuel leaks or other fuel system abnormalities if you suspect the presence of alcohol in gasoline exceeds the current government regulation limits.

Refer to the manual for your outboard engine regarding recommended octane ratings specific to your engine. As a minimum, unleaded gasoline with an AKI (R+M)/2 octane rating of 87 should be used unless otherwise stated in the engine specifications.

**BIOBUTANOL (Bu16) FUEL.** Biobutanol is a four-carbon alcohol produced from renewable, plant-derived energy sources in a fermentation process similar to beer and wine production. Biobutanol delivers more renewable energy content than ethanol while remaining compatible with current vehicles, boats, and infrastructure. Biobutanol does not phase separate in the presence of water like ethanol and is less corrosive to fuel system components such as fuel tanks, fuel fittings and fuel hoses. Biobutanol blended fuel (either isobutanol or n-butanol) may be used in all Manitou Pontoon Boats. Biobutanol blended fuel (Bu16 - up to 16.1% by volume) has been approved for use by the National Marine Manufacturers Association (NMMA).

### USE IN NORTH AMERICA:

NOTICE - Do NOT use fuel from fuel pumps labeled E85. Never experiment with other fuels. The use of unleaded gasoline containing alcohol above the percentage specified by government regulations is not recommended. Use of fuel labeled E15 is prohibited by U.S. EPA Regulations

### USE OUTSIDE NORTH AMERICA:

The use of unleaded gasoline containing alcohol above the percentage specified by local government regulations is not recommended.

### USE IN THE EUROPEAN UNION:

Deployment of Alternative Fuels Infrastructure Directive 2014/94/EU. This directive provides harmonized labeling across Europe to effectively assist consumers in identifying the compatibility of fuels supplied at refueling points with an engine. All Manitou Pontoon Boats are compatible with up to 10% ethanol fuel blends (E10). The decal shown below should be present near the fuel filler cap of all recreational vessels.

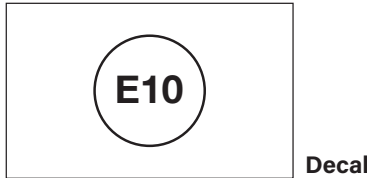

## FUELING

When fueling your boat's main fuel tank, follow these steps:

- Working in a well-ventilated area, remove the fuel tank cap. The contents may be under pressure; remove the cap carefully.
- Insert the fuel supply nozzle.
- After filling the tank to approximately 25 percent capacity, stop the pump, and inspect the engine and fuel tank area for signs of possible leaks or other issues.
- If no issues are detected, continue pumping.
- Stop filling the tank before fuel overflow occurs. Doing so leaves space in the tank for thermal expansion.

Note: If fuel cannot be pumped into the tank at a reasonable rate, contact your Manitou dealer.

Remember that gasoline is most often pumped from underground tanks so it is cooler than the outside air. As the gasoline warms, it will expand. This can cause a fuel tank overflow if the tank is completely full.

**Note: It is important to manually control the pump. Do not use the automatic shut-off valve on the nozzle. Instead, stand by the tank and control the pump manually.**

At all times, be aware that gasoline is very volatile. Follow these precautions while fueling:

- Shut off the engine.
- Extinguish all lit cigarettes or any other nearby open flames.
- Be cautious when fueling during hot weather.
- Stop fueling before the tank reaches capacity to allow for fuel expansion.

## WARNING

**Leaking fuel is a fire and explosion hazard. Regularly examine your boat's fuel system for leaks or corrosion. If needed, ask a marine service center to complete this inspection.**

- Follow all safety labels posted on the fuel pump.

## LAUNCHING YOUR BOAT

Launch ramps are normally busy places, so be ready to launch before approaching the ramp. Prior to backing down the launch ramp, complete these steps:

1. Remove all tie-downs.
2. Load all personal gear.
3. Make sure drain plugs are installed on your boat.
4. Properly secure all loose gear.
5. Lock the winch and trailer unit.
6. Inventory your safety equipment.
7. Disconnect the trailer wiring from your vehicle.

For a successful launch, take note of the following precautions:

- Confirm the length of the ramp and depth of the water. A short ramp can cause trailer damage.
- Ensure that all people, trailers, and other impediments are out of the way before you begin backing up.
- Once the boat is in the water, lower the engine into the water, and start it according to its owner's manual.
- Remove the safety cable and drive the boat off the trailer.
- Once the boat is in the water, cut the engine, tie off the boat, and remove your trailer from the launch ramp immediately. This allows others to launch their boats.

**Note: If it is difficult to move the boat off of its trailer, it may be necessary to back into deeper water.**

## CAUTION

**The launching information and instructions provided in this manual are intended to provide general guidelines only. Refer to your NMMA manual and trailer owner's manual for additional information.**

## BOAT CAPACITY INFORMATION

It is important to know the capacity of your boat so that you do not allow it to become overloaded. An informational plate showing the capacity of your Manitou is located on the captain's stand. This plate shows maximum weight, person, and horsepower capacities.

**Note: The weight rating for your boat includes the engine, people, and all of your gear.**

The engine horsepower should never exceed the posted rating. Exceeding this rating may cause damage to your boat and will void your warranty.

### **⚠ CAUTION**

**Read, understand, and follow the capacity information for your boat. The maximum capacity plate is located on the captain's stand.**

## BOARDING

Require that your passengers board the boat in an orderly and careful manner, one person at a time. Prohibit jumping into the boat or entering by climbing onto the pontoon tubes. Always use a boarding ladder when entering or exiting from the water.

Review the following safety rules with your passengers. Note that while your boat's floorplan may differ from that shown in the following diagram, the same safety rules apply.

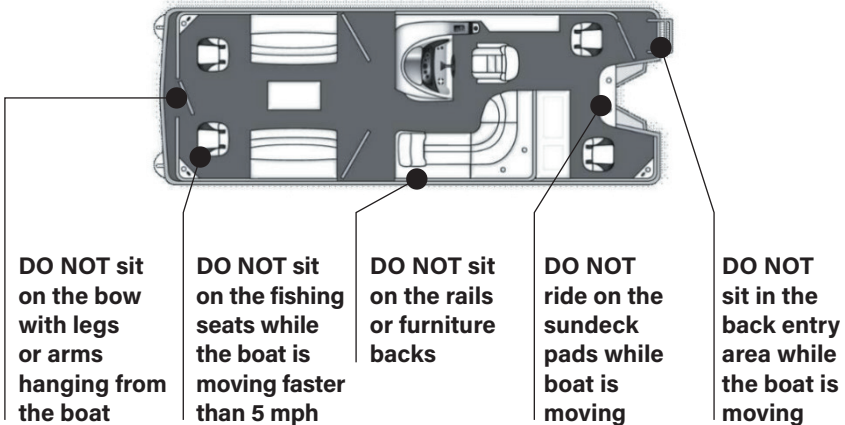



**DO NOT sit in rearward facing seats when the boat is moving**

**DO NOT sit in rearward facing seats when the boat is moving**

**DO NOT sit or stand on swim platform when the boat is moving**

## STOWING ONBOARD GEAR

Your boat has been designed to accommodate storage of gear and belongings. To avoid loss overboard, tripping and falling hazards, or problems with boat operation, loose items should be stowed in the boat's storage compartments before your departure from the shore or dock.

When loading large or awkwardly shaped items onto your boat, do not attempt to carry them on board yourself. Instead, pass the object to a person who is already on the boat. Do the same when unloading your boat.

## WEIGHT DISTRIBUTION

Onboard weight distribution affects the ride and handling of your boat. It is important to disperse the weight of passengers and onboard gear evenly in your boat. Avoid excessive weight at either the bow or the stern of the boat.

**Note: Excessive weight at the bow of your boat can cause the nose to dive underwater, resulting in rapid deceleration.**

## STEERING

Boat steering is affected by a number of forces, and is different from steering a car. A boat is not self-centering, and engine and propeller torque, trim tab settings, boat speed, and the actions of waves and currents can all affect steering. For a safe ride, a boat driver must pay constant attention to steering. Keep the following in mind as you steer your Manitou:

- Be aware that as you steer, the stern responds first by swinging in the opposite direction of the bow. The bow follows a smaller turning radius than the stern. When you are leaving the dock or trying to avoid an object in the water, awareness of this swing is critical.
- Leave plenty of room to make a turn.
- Slow the speed of your boat while turning, and avoid tight, fast turns. Sharp, high-speed turning can endanger your passengers and cause you to lose control of the vessel.
- Leaving the engine trimmed up when you are turning can result in engine ventilation. For more information about engine ventilation, please refer to the owner's manual for your engine.
- Trim the engine down for better handling, especially when you are making tight turns.
- If you are caught in heavy waves, head either directly into the waves or enter them at a slight angle. Reduce your speed, but maintain enough power to move your boat safely.

## NAVIGATION AND RIGHT-OF-WAY RULES

Knowing the rules of navigation and right-of-way can prevent boating accidents. Here are several important rules to keep in mind at all times:

- When meeting another boat head on, keep to its starboard, or right, side whenever possible.
- When crossing the path of another boat, you must give way if the other boat is on your starboard side.
- When passing another boat, the boat you are passing has the right-of-way.
- When your boat is being passed, you are expected to maintain your original direction and speed, in order to allow the other boat to pass safely.

**Note: Sailboats, windsurfers, kayaks, canoes, and paddleboards have the right-of-way under all circumstances.**

You are likely to encounter boaters who do not know or follow these rules. In that situation, you must give way in order to avoid a collision.

## BOAT SPEED

The safest speed for your boat depends on water and weather conditions, your boating experience, and the amount of boat traffic present. Your maneuvering speed, or maximum speed at which you can turn your boat and not lose control, must also be taken into account. In general, when you encounter any potentially hazardous situation, adjust your boat speed accordingly. Slower speeds provide more time to respond.

For example, never travel directly behind a water skier. The boat pulling the skier may stop suddenly, causing you to collide with it in seconds. Here's the math for this situation: At 25 MPH, your boat travels more than 35 feet per second. If a boat 200 feet ahead of you stops suddenly and you continue traveling at 25 MPH, your boat will collide into the stopped boat in less than six seconds.

**Note: If the bimini top is open, do not exceed 25 MPH.**

## TRIMMING

The outboard engine can be trimmed to adjust your boat's angle for given loads and water conditions. Follow these performance tips for trimming your Manitou:

- On VP and SHP models, keep the engine trimmed down when accelerating and turning, but trim up while underway.
- Manitou V-Toon pontoons with higher horsepower engines are likely to ride higher in the water, allowing more rapid acceleration and greater responsiveness in turns.
- Avoid over-trimming. Too great a trim hinders performance and creates excessive engine noise and motor ventilation.

**Note: On two-tube pontoon boats, trimming the motor does not significantly affect the boat's riding attitude.**

## DOCKING

Always approach a dock slowly, and ideally against the wind or current. As your boat nears the dock, swing the boat parallel to the structure. If the wind or current is from the stern of your boat, approach the dock slowly at a slight angle, with the engine in slow reverse.

Tie down your boat on the downwind side of the dock. Use fenders over the side between the boat and the dock to protect your boat from damage.

### WARNING

**Never use your hands or feet to push your boat away from a dock. Use a boat hook or other suitable device.**

## LOADING AND TRAILERING YOUR BOAT

To load your boat onto its trailer, follow these steps:

1. Back the trailer down the launch ramp until the bunks are about three-quarters submerged in the water.
2. In the towing vehicle, set the parking brake. Also, put the transmission into Park for an automatic transmission, or leave it in gear for a manual transmission. Turn off the vehicle's engine.
3. Place blocks behind the towing vehicle's rear wheels.
4. In the boat, with its speed set to minimum, approach the trailer. Ensure that the engine is trimmed up as far as possible to avoid hitting the shore bottom.
5. Center the boat on the support bunks and steer the boat straight toward the winch stand. Drive the boat between the bunks at a slow speed, using short power bursts.
6. Once the boat is loaded, turn off the engine and tilt it up. Attach the safety cable and exit the ramp to allow others to load.
7. Turn off all boat accessories and the master switch.
8. If your boat is equipped with a livewell, drain it. Also, run your bilge pump to drain the in-tube storage and transom, if applicable.
9. Connect the trailer light harness, and check all lights.
10. Lower and secure the canopy.
11. Secure the engine.
12. Attach the tie-down straps. For more information, refer to your boat trailer owner's manual.

### CAUTION

**The loading information and instructions provided in this manual are intended to provide general guidelines only. For additional information, refer to your NMMA manual and trailer owner's manual.**



## BOAT TRAILER LAWS

Boat trailer laws vary from state to state and province to province. It is your responsibility to understand the laws of the state or province in which you are boating.

## TOWING CAPACITY

Towing capacity is determined by several factors. The first factor is your vehicle's Gross Vehicle Weight Rating (GVWR). The GVWR is determined by the vehicle's manufacturer. It specifies the maximum weight that can be safely carried by the vehicle. The total weight of the vehicle, including passengers and cargo, can be compared to the GVWR to determine the weight capacity available for pulling a trailer.

**Example: A truck has a GVWR of 9,600 pounds, and a curb weight of 6,600 pounds. This leaves a 3,000-pound carrying capacity.**

Trailers also display a rating label that lists the maximum carrying capacity of the trailer, or Gross Trailer Weight Rating (GTWR). Do not exceed your trailer's GTWR at any time. Compare the total weight of the boat, including the engine, fuel, water and all other items being carried on the boat, to the GTWR.

### **WARNING**

**Exceeding your trailer's capacity is dangerous and may result in personal or property damage.**

## TONGUE WEIGHT

The tongue weight is the percentage of the total weight of the loaded trailer on its tongue, which is the V-shaped portion of the trailer that extends from the trailer frame to the coupler. The ideal tongue weight falls between five and ten percent of the GTWR.

**Example: If the weight of the loaded trailer is 3,000 pounds, then the weight on the tongue should be no less than 150 pounds and no more than 300 pounds.**

Excessive tongue weight causes the front end of the towing vehicle to sway during driving. Alternatively, insufficient tongue weight causes the trailer to sway or fishtail.

## TRAILER HITCH

Hitches are specified by five classes, labeled from Class I to Class V. These classes relate to the hitch's capacity in pounds.

Always use a hitch with the same class number as the trailer. Most boat trailers connect to a hitch ball that is connected to the towing vehicle. Note that the hitch coupler on your trailer must match the size of the hitch ball on your towing vehicle. The correct ball size needed is usually marked on the trailer coupler.

## SAFETY CHAINS

Safety chains are a precaution in case the trailer uncouples from the hitch during transport. The chains keep the trailer connected to the towing vehicle. Always use these safety chains, and cross them for added security.

For specific operation and safety instructions, refer to your trailer owner's manual.

## BACKING A VEHICLE WITH A TRAILER

If you do not have experience backing up with a trailer, practice backing up with a trailer before you go to a launch ramp site. It is important to become accustomed to using your trailer. Do not oversteer when backing up. Instead, turn the steering wheel gradually. Enlist the help of someone familiar with maneuvering a trailer, and practice in an open area at first, until you get a feel for backing up safely.

**Note: Backing up a trailer is the opposite of backing up your vehicle. If the trailer needs to travel to the right, you will turn the steering wheel to the left. The opposite is also true.**

## TRAILERING REMINDERS

To avoid accidents, keep the full height of your trailered Manitou in mind at all times. Measure the height of your boat on the trailer and allow for an additional eight inches of clearance. Keep the following guidelines in mind:

- When traveling with your boat and trailer, check all routes for vertical clearance.
- Always be aware of clearances when entering filling stations, motels, or other places where overheads are present.
- Stopping time and distance will be longer after loading your boat at a boat ramp because trailer brakes will be wet. Adjust your driving accordingly.
- After loading your boat onto the trailer, apply the brake several times at a slow speed to dry the brake pads.
- Stow and store loose items to prevent objects from blowing from the boat or becoming damaged during transport.
- During trailering, tightly secure the bimini top using all available tiedowns. Do not trailer with the top open or in the up and zipped ("radar") position. Instead, use the trailering brackets to secure the top or remove it.
- Store the table and any seat pads that are not hinged and attached.
- On two-tube pontoons with large motors, consider using a transom saver to support the motor. An unsupported motor may cause tube or deck damage and could void your warranty.
- Do not trailer with the mooring cover installed. Doing so may result in damage to the cover and your boat. Should the mooring cover detach from the boat completely, it may be hazardous to other vehicles.
- If you have a sport arch, do not lower it before trailering. Make sure the arch is fully raised with the star knobs securely installed.

## WARNING

**Wet trailer brakes may significantly increase stopping distances.**

## CAUTION

**The height of your trailered boat can be a safety factor during transport. Keep this in mind while considering your travel route.**

## STORING YOUR BOAT

When preparing your boat for storage, follow these basic storage recommendations:

- Drain any freshwater systems to prevent freezing and damage to tanks and lines.
- Fill the permanent fuel tank to minimize condensation. Use a gas stabilizer, making sure to follow the label directions on the stabilizer and in your engine manual.
- Remove water from the livewell, motor pod, in-tube storage chamber, and storage areas.
- Lubricate the steering mechanism, shifter, and shift cables. For more information, review your engine owner's manual.
- Prepare your engine for storage. For more information, review your engine owner's manual.
- Store the boat in a dry, clean area. Store indoors if possible.
- Painted fiberglass components must be covered with a barrier material before shrink-wrap to protect it from damage.
- Cover your boat with shrink-wrap during storage to help keep it clean for future use. Note that the mooring cover is not made for winter storage. Do not allow excessive ice or snow to build up on the shrink-wrap.
- If you store your boat on a trailer, position the trailer on blocks to keep its wheels off the ground. This helps avoid tire deterioration.

**Note: When winterizing a V-Toon, check the sealed transom for water by opening the access plate. If water is present, remove the drain plug located at the bottom rear of the center tube and let the water drain out. Then coat the drain plug with a thread sealant, and replace it.**

**Note: If a significant amount of water was present, consult your dealer to determine its cause.**

## BLOCKING

If you will be placing your Manitou on blocks for storage, it is important to place the blocks under the most structurally sound areas of the pontoon. The diagrams below illustrate these locations for two- and three-pontoon hulls. Ensure that the boat's weight is evenly distributed between the blocks.

**Note: The boat should only be lifted vertically from the bow and stern mooring eyes. Do not lift with the straps at an angle—the straps must lift the boat directly from above.**

### TWO-PONTOON HULL

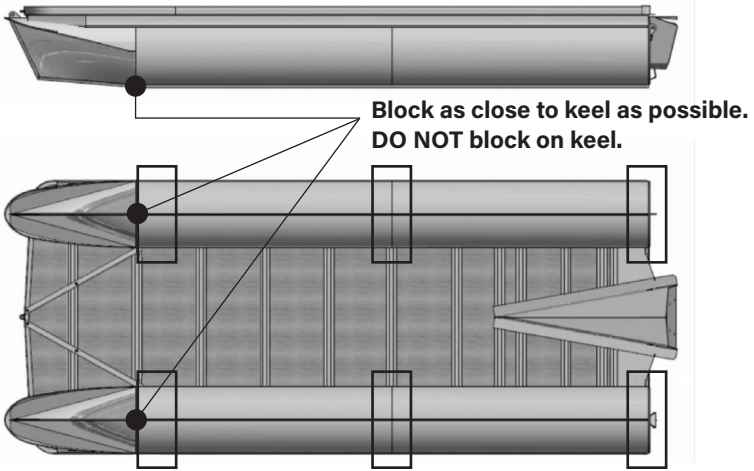

### THREE-PONTOON HULL

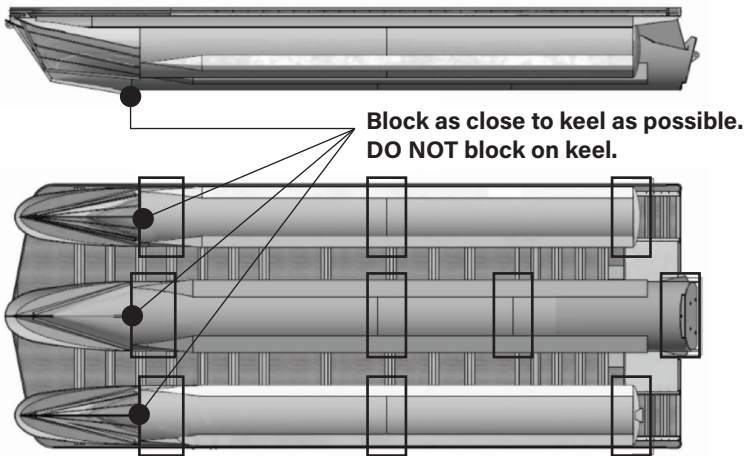

# SECTION 6: ELECTRICAL EQUIPMENT

In this section, you will learn more about your Manitou's onboard electrical systems, including instruments, controls, wiring, and other components.

Please note that some items described in this section may not be present on your Manitou model. This section provides a general overview of onboard equipment. For more detailed information, check with your Manitou dealer.

## ELECTRICAL WIRING SYSTEM

All systems on your boat are powered by a 12-volt DC negative ground electrical system. This system has been fully inspected at the Manitou factory. It is recommended that any work involving adding electrical equipment to your boat be completed by your Manitou dealer. Incorrect wiring of electrical circuits can result in fire and damage to your boat's electrical system.

All Manitou models, with the exception of the Aurora LE and Aurora Angler LE models have a fuse block, as pictured.

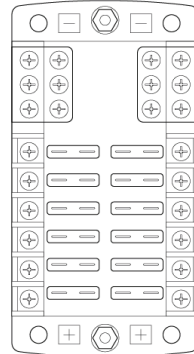

## MAXIMUS DCM

The XT and LX models are equipped with a digital switching system. This system, located under the helm, allows the user to control, monitor, and troubleshoot the electronics of the boat through the display. More information about the Maximus DCM can be found in your owner's package.

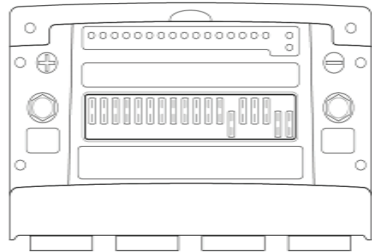

### **⚠ CAUTION**

**Refer to the owner's manuals for your engine and trailer for their specific wiring and electrical requirements.**

## BATTERIES

The batteries on your boat were installed by your Manitou dealer. Inspect the batteries frequently for cleanliness and tight connections. Confirm that they are tied down securely. The battery compartment should be well ventilated at all times. Please refer to your battery owner's manual for further instructions.

If you need to replace a battery, install the same type that was originally mounted on your boat. The replacement battery must meet the minimum requirements specified by your engine owner's manual.

## LIGHTS

The lights on your Manitou serve different purposes. Some are for navigation and safety needs, while others are for your comfort and convenience. The lights present on your Manitou vary by model. Please contact your Manitou dealer before adding any extra lights to your boat. Navigation Lights, Including Stern and Bow Lights  
Boats must display navigation lights when they are being operated between sunset and sunrise and during periods of poor visibility, including rain and fog. These lights help to alert other boaters of your presence and course.

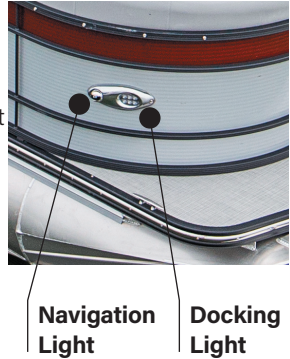

Follow all laws concerning the use of navigation lights. The green navigation light is always on the starboard (right) side of the boat. The red navigation light is always on the port (left) side of the boat. Please keep this information in mind as you see other boats approaching you on the water.

**Note: The appearance of the docking and navigation lights on your boat may differ from those shown here.**

## DOCKING LIGHTS

Docking lights are intended to be used only while you are docking the boat at night. Do not use these lights while cruising on the water. The lights are very bright, and may temporarily blind other drivers.

## ANCHOR LIGHT

The anchor light is a white light located on the top of your bimini, sport arch, or tower. Use this light while your boat is anchored on the water after dark so that other boaters can see your boat. It must also be used while the boat is underway after dark, with the three position Anchor/ Navigation switch set to the navigation position. While at rest, with the anchor down, set the switch to the anchor setting. Once underway again, return the switch to the navigation position.

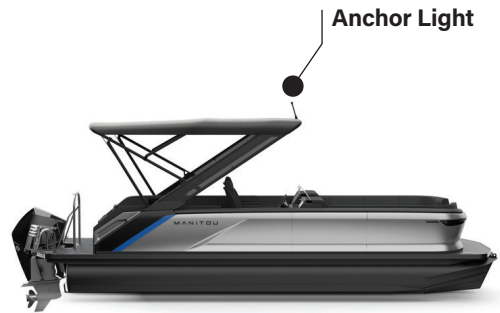

**Note: It is important to know and follow all laws related to the use of the anchor light.**

## SWITCHES

Electrical switches control the supply of power to your boat's components. Switches may be two-position (either on or off), or three-position (in which the center position is off). On a three-position switch, the switch position determines which components are activated. Some switches have an adjacent push-button reset breaker, and others have automotive-style fuses mounted inside the helm. These breakers and fuses protect the electrical components from damage by power surges.

**Note: If you reset a breaker and it immediately trips again, there may be an electrical problem that needs attention. Do not attempt a second reset. Consult your Manitou dealer for more information.**

If you replace a breaker, replace it with the same size breaker. Note, too, that there are other switches that are not on the dash, such as the switches for the bilge and galley pumps. These have a pop-breaker near their location.

## INSTRUMENT PANEL

The instrument panel installed on your Manitou displays information about your engine and related systems. The instrument panel is located on the helm of your boat. The normal readings of the gauges provide a reference point to judge your boat's operations. Although some gauges fluctuate, you should investigate the cause of any sudden or irregular changes in gauge readings. Some of your boat's switches are also found in the helm area.

## DIGITAL DISPLAY

Your Manitou will have a digital display on the instrument panel. This screen displays information and provides controls for a variety of different functions on your boat. It integrates instrumentation and controls from electronically-controlled engines communicating via SAE J1939 and NMEA 2000 protocols. The display is a multi-functional tool that lets you view different display settings, engine parameters and service codes.

To clean your digital display, use a soft cloth. If necessary, you can also use window cleaner or alcohol to clean the glass portion of the display. Never use harsh or abrasive cleaners on the unit.

For information on using the digital display, review the Garmin® manual included in your owner's packet.

## GUIDE TO YOUR BOAT'S INSTRUMENT PANEL

The information that follows provides a reference for your boat's gauges, including normal gauge readings where applicable. Your boat's switches are also shown. Switches and gauges present in the helm area vary by Manitou model. Use the table below to locate your model, then turn to that page.

# INSTRUMENT PANEL DESCRIPTIONS

## AURORA LE, AURORA ANGLER

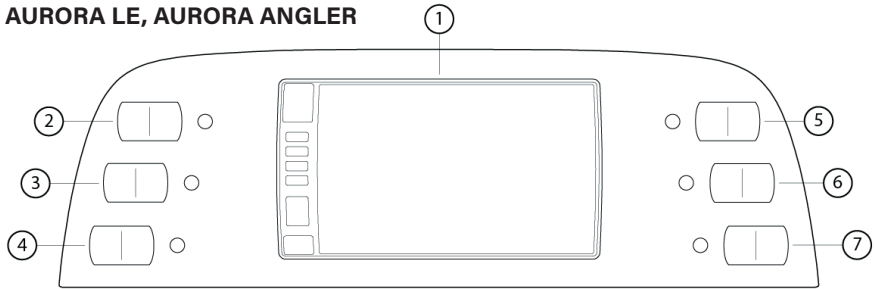

- 1. The Garmin digital display provides information for monitoring your boat's performance. It allows you to view engine health messages, including diagnostic messages, fault alerts and parameter information. More information on the Garmin digital display can be found in your owner's package. It has detailed information on the functionality and customization options of this display unit.
- 2. Navigation and Anchor Lights
- 3. Accessory or Livewell
- 4. Accessory
- 5. Docking Lights
- 6. Horn
- 7. Accessory

## OASIS, OASIS ANGLER, ENCORE, ENCORE PRO ANGLER

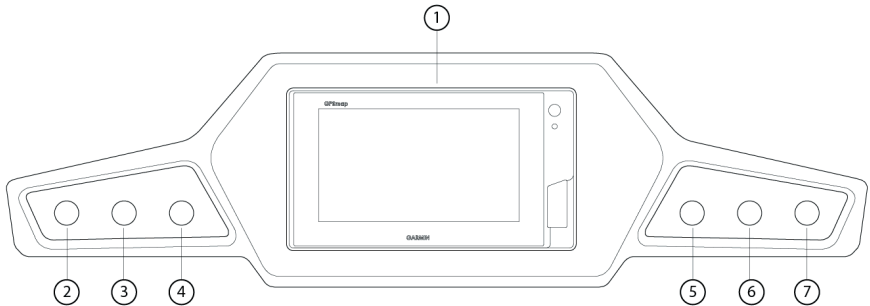

- 1. The Garmin digital display provides information for monitoring your boat's performance. It allows you to view engine health messages, including diagnostic messages, fault alerts and parameter information. More information on the Garmin digital display can be found in your owner's package. It has detailed information on the functionality and customization options of this display unit.
- 2. Docking Light
- 3. Navigation and Anchor Lights
- 4. Horn
- 5. Courtesy Light
- 6. Accessory
- 7. Accessory or Livewell



---

## EXPLORE MODELS

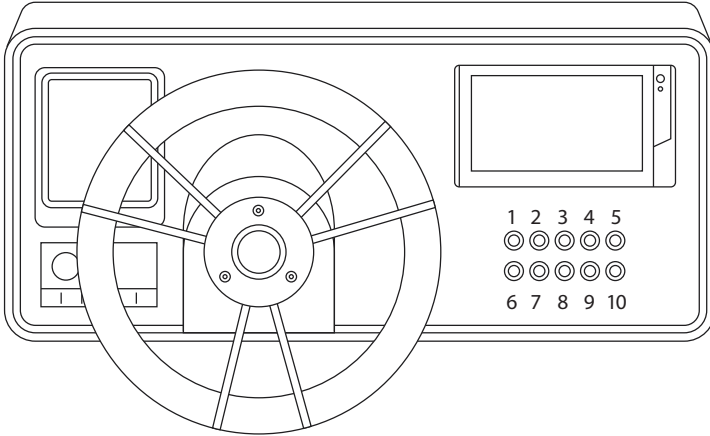

- |                               |                   |
|-------------------------------|-------------------|
| 1. Navigation & Anchor Lights | 6. Aft Bilge Pump |
| 2. Docking Lights             | 7. USB outlet     |
| 3. Courtesy Lights            | 8. Accessories    |
| 4. Exterior Lights            | 9. Accessories 1  |
| 5. Forward Bilge Pump         | 10. Accessories 2 |

---

## CRUISE MODELS

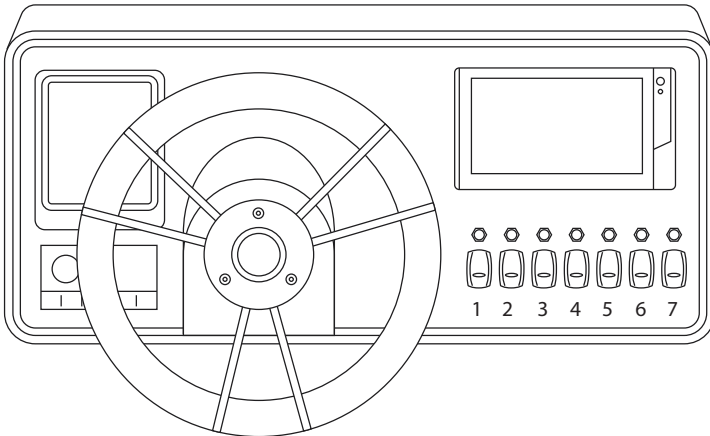

- |                       |                               |
|-----------------------|-------------------------------|
| 1. Horn               | 5. Courtesy Lights            |
| 2. Accessory          | 6. Dock Lights                |
| 3. Forward Bilge Pump | 7. Navigation & Anchor Lights |
| 4. Aft Bilge Pump     |                               |

---

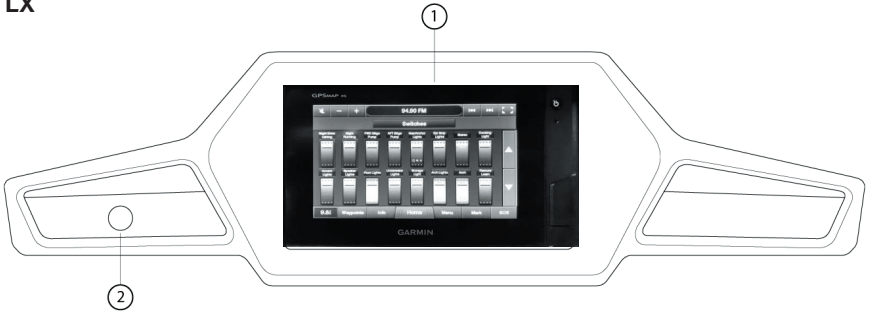
**LX**

1. The Garmin digital display provides information for monitoring your boat's performance. It allows you to view engine health messages, including diagnostic messages, fault alerts and parameter information. More information on the Garmin digital display can be found in your owner's package. It has detailed information on the functionality and customization options of this display unit.  
Switches and lighting controls are accessed through your Garmin touch screen.
2. Horn

---

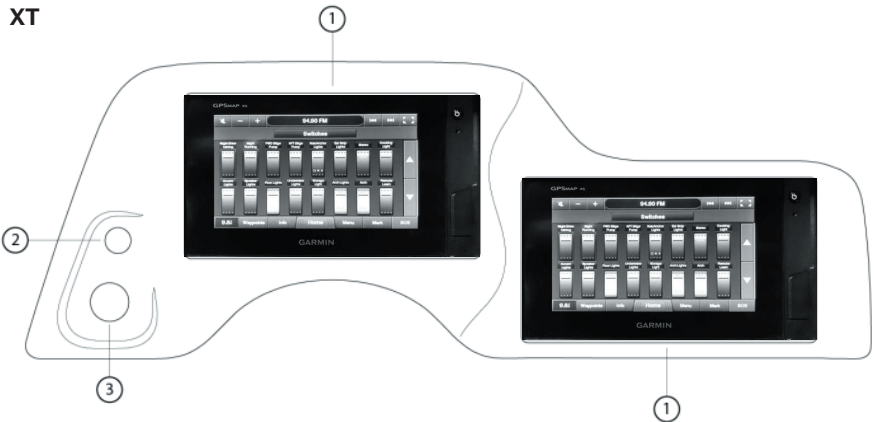
**XT**

1. The Garmin digital display provides information for monitoring your boat's performance. It allows you to view engine health messages, including diagnostic messages, fault alerts and parameter information. More information on the Garmin digital display can be found in your owner's package. It has detailed information on the functionality and customization options of this display unit.  
Switches and lighting controls are accessed through your Garmin touch screen.
2. Horn
3. USB Power

# SECTION 7:

## CONTROLS

Having confidence in using the controls on your boat is essential for safe and proper operation. Careful practice on the water will aid in building the skills needed to make the most of your Manitou's controls. This section provides an overview of the steering, engine, and shift and throttle controls that may be present on your Manitou.

### STEERING SYSTEM

Your Manitou model is equipped with one of several possible steering systems. It is important to review the owner's manual for your specific steering system for additional information concerning maintenance, use, and safety. Also, schedule regular steering maintenance with your Manitou dealer.

Your Manitou boat is equipped with one of the following steering systems:

- **TILT MECHANICAL SYSTEM:** As with the no-tilt mechanical system, the steering wheel connects to a cable that transfers the wheel's movement to the engine. However, with this steering system you will be able to adjust the tilt of your steering wheel on the helm. Use this feature to set the height and angle of the steering wheel for your comfort.
- **HYDRAULIC SYSTEM:** With this steering system, the steering wheel movement pumps hydraulic fluid through the hoses to a cylinder that transfers movement to the engine. A hydraulic steering system makes controlling the boat easier because turning the steering wheel requires less force.
- **POWER ASSIST STEERING:** The power assist unit uses an electronically controlled hydraulic pump to provide steering power to your steering system. Power assist steering provides the driver with an automotivestyle steering experience, even with larger outboard engines.

All steering systems require periodic maintenance to remain trouble-free and safe. Regular checks are essential. Visually inspect the cables at least twice each month during boating season. If you detect problems in the steering system, do not use the boat until your dealer has inspected the system and resolved the problem.

Be aware that steering varies from boat to boat, depending on the engine and make of boat. Getting a feel for your own boat's steering system is important. Before each outing, turn the wheel a full turn from left to right. Check that the outboard engine is turning correctly, freely, and smoothly.

## AUTOPILOT & AUTOMATIC SET POINT FUNCTIONS (IF EQUIPPED)

An autopilot or an automatic set point function will allow your boat to automatically hold a course, a heading, a position or a drift point by controlling the engine(s).

Some engines are equipped with an automatic engine control systems. These automated systems do not constitute a replacement for the driver.

The driver is responsible at all time for the safety of the boat's occupants and its surroundings.

Refer to the controls manual provided with the owner's packet for details of operation of these automatic functions.

### **WARNING**

**The driver must always perform active supervision even when using the autopilot or any automatic engines features. Activating these features will make components move automatically and could lead to injuries or even death.**

### **WARNING**

**Always make sure no swimmers or other obstacles are near the engine or the engine propeller area, especially when these automatic functions are activated.**

## OPTIONAL JOY STICK STEERING

Your Manitou may be equipped with the optional joy stick steering feature. If so, please refer to the joy stick steering system manual provided in the owner's packet for specific operation. Then, follow the steps below to become familiar with the system during your initial on-the-water trial:

- With the engine lanyard properly connected to you, and all passengers securely seated, carefully proceed to a section of deep, open water at a slow to moderate speed.
- Once in open water that is deep enough to ensure that you will not run aground, try various maneuvers with the boat at different speeds. Do so until you are fully comfortable operating the boat.
- Be sure to spend some time backing up at a slow speed.



Use the trip to get a feel for the steering response. Once you are familiar with the operation of the joy stick steering feature, run the boat in a safe, normal fashion.

## OPTIONAL DUAL ENGINE CONTROLS

Your Manitou may be equipped with dual engine controls. If you are unfamiliar with the operation of these controls, it is important to take time to learn more about how to safely and efficiently maneuver your boat using these controls.

Each lever of the dual engine control operates a single engine. The left (or port) lever adjusts the speed and rotational direction of the port-side engine. In the same way, the right (or starboard) lever operates the starboard-side engine. When the



two levers are in the same position, the engines work together to move the boat in a straight line. When the two levers are in different positions, the boat responds by pivoting or spinning in one direction or the other, according to the positions used.

To master the operation of the dual engine control, first practice on the water in an area where there is no risk of collision or running aground. You will also want to practice docking maneuvers using the dual engine control. Remember at all times that boat speed affects the driver's ability to maneuver. At first, keep your engine speeds low to allow for safe practice. Increase to higher speeds as you gain familiarity with the controls' effect on steering. For detailed instructions on using the optional dual engine controls feature, please refer to the controls manual provided in the owner's packet.

## SHIFT AND THROTTLE CONTROL SYSTEM

The shift and throttle control system on your boat will vary depending on the brand of motor and the steering options you have selected. The control system described in this section may vary slightly from the control on your boat. For specific maintenance, use, and safety information, refer to the shift and throttle control owner's manual provided by the engine manufacturer.

### **FORWARD AND REVERSE**

To shift into forward, rotate the control lever forward about 35 degrees. To shift into reverse, rotate the control lever backward.

### **FAST IDLE BUTTON**

When starting is difficult, you can use the fast idle button to rev the engine in neutral. Set the control lever to neutral and, while pushing the fast idle button, rotate the control lever. Note that you can open the throttle without shifting into gear. The fast idle button can only be depressed when the engine shift lever is in neutral. Use caution with the fast idle control.

### **POWER TRIM AND TILT SWITCH**

The power trim and tilt switch is attached to the control lever grip. It is operated using your thumb. Pushing the switch upward trims and tilts the motor upward. Pushing the switch downward trims and tilts the motor downward. While the trim and tilt switch is in use, the trim gauge located on the instrument panel will indicate the angle of the propeller relative to the hull. As you push the switch up or down, the gauge should reflect this change.

### **TIPS FOR USING THE SHIFT AND THROTTLE CONTROL SYSTEM**

The following tips will aid you when you are using the shift and throttle control system:

- When shifting between forward and reverse, always pause for a few seconds in neutral before reversing the propeller. This will prevent damage to the engine.
- When maneuvering at slow speed, you can reverse the propeller to slow or stop the boat's forward movement.
- When moving in reverse, gradually increase boat speed. Accelerating at high speed while in reverse may create a wake that can flood the stern area of your boat.

Please keep in mind that this information may not apply to your specific shift and throttle control system. To learn more, read the shift and throttle control owner's manual enclosed with your Manitou owner's packet. You may also consult with your dealer or the engine manufacturer for more information.

# SECTION 8: OTHER COMPONENTS

## LIVEWELL

Your Manitou may be equipped with a livewell. A livewell is a tank used to keep bait and harvested fish alive. The livewell is aerated by the fresh water that is pumped into the tank.

You can turn the livewell pump on and off manually by using the designated accessory switch in the helm area. When this switch is in the On position, the pump runs continuously.

It is important to be aware of water and air temperatures to determine when and how often you should aerate the livewell. The pump draws water from below the waterline of the boat and pumps it into the livewell tank through the aerator head. The aerator head can be adjusted to control the volume of water flowing into the livewell tank. Oxygen content increases as incoming water hits the surface of the water already in the livewell tank. This added oxygen helps keep fish in the livewell alive.

**Note: The pump works best when the boat is at rest or moving very slowly. At faster speeds, the pump is unable to draw water.**

The stand pipe overflow tube keeps your livewell tank from overflowing with water. It sets the maximum water level allowed in the tank. As water enters and fills up the tank, the stand pipe allows the overflow to drain out below the deck of the boat. Stand pipes can be cut down if lower water levels are desired. For additional information, consult your Manitou dealer.

## SPORT TOWER

Your Manitou may be equipped with a sport tower. The tower should be in the raised position most of the time, including during towing. Some circumstances, such as passing under a low bridge while on the water or fitting under a lift at a dock, may require lowering the sport tower. The tower is lowered and raised via the digital display. The top is designed to be open when operating at speeds less than 45 MPH.



### **⚠ CAUTION**

**If a sport tower is present on your Manitou, note the tower must be in a raised position during towing.**

## ROTAX OUTBOARD EQUIPPED BOAT MODELS

Stand clear of the swim platform when raising or lowering the outboard. When tilted up, the outboard will push open the swim platform hinged section, creating a pinch point hazard. Personal injury can result from contact with the moving swim platform section.



### **⚠️ WARNING**

**Do not mount anything to the surface of the swim platform. Serious injury or death could occur from flying objects as a result of the outboard engine impacting an underwater object and forcing the swim platform open.**



Oil fill (A) and freshwater flushing port (B) are located on the port side of the swim platform. The oil level is displayed on the instrument cluster.

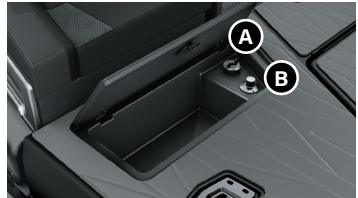

## STERN BOARDING LADDER

The stern boarding ladder is located in the stern of the boat and comes as a standard feature. Do not leave your ladder deployed while the boat is under power.



### **⚠️ WARNING**

**Do not use any ladder while the engine is running. Swimmers must not exit or enter the boat when the engine is running or the propeller is in motion.**

### **⚠️ WARNING**

**Always use a boarding ladder to enter and exit your boat. Do not climb on the pontoon tubes.**

### **⚠️ CAUTION**

**The maximum weight rating for the ladder is 300 pounds.**



# SECTION 9: CLEANING YOUR MANITOU

Your Manitou is designed to provide lasting enjoyment now and into the future. In this section, you'll learn the best practices for cleaning each of the surfaces in your boat. Following these practices consistently will extend the life of the quality materials built into every boat.

If you are cleaning your boat on the water, confirm that any cleaning products used are safe for release into aquatic environments. Never wash non-biodegradable chemicals into waterways.

## FLOORING

Manitou boats offer two types of flooring—vinyl and Compass HB. The care and maintenance of these flooring types is described in this section.

### VINYL FLOORING

Your Manitou may have vinyl flooring. As with all flooring, this surface will benefit from regular cleaning. Follow these steps for cleaning vinyl flooring:

1. Rinse the vinyl flooring with cool water, and use a deck brush or other soft-to-medium stiffness brush to remove grime and debris.
2. Apply floor soap or cleanser with the brush, and allow the cleanser to penetrate and loosen the soil and debris for two to three minutes.
3. Lightly scrub the area with the brush, and then rinse the area with clear water.
4. If needed, repeat this process.

Certain substances can stain vinyl flooring. Avoid spilling chemicals, dyes and inks, and other materials. Rubber tires may also cause stains. When necessary, you may be able to remove some stains with a vinyl floor cleaner. Do not use harsh chemicals such as tar remover, acetone, kerosene, or oxalic acid. Test any new product in an inconspicuous location before use, and follow label directions carefully.

**Note: Some cleaning products may make vinyl flooring slippery, during cleaning or afterward. When using unfamiliar products, test them carefully to reduce the likelihood of slips and falls.**

Over time, the plywood subflooring on your Manitou may lift slightly at its seams. If a small ridge in your vinyl flooring becomes noticeable, it will not affect the integrity or longevity of your flooring.

## CAUTION

**Heavy or sharp objects may permanently damage vinyl flooring.**

## SPRADLING COMPASS HB™ FLOORING

Your Manitou may have Spradling Compass HB flooring. This flooring is a hybrid material that mixes both PVC and carpet yarns to make a highly durable surface well-suited to marine environments.

Caring for Spradling brand flooring is similar to caring for other types of marine flooring. Regularly remove soil and debris by vacuuming or hosing off the flooring. If a deeper cleaning is needed, standard carpet cleaning products may be used. Allow the flooring to dry completely before storing. Do not use acetone, Pine-Sol®, or citrus-based cleaners on your Compass HB flooring.

## FABRIC TOPS AND COVERS

Your Manitou includes a bimini top as a standard feature, and may also have a mooring cover or deck enclosure. These are made with Utopia HD® polyester fabrics designed for use in marine environments. This fabric is specially coated to resist water, sun, and mildew damage.

**Note: Although the fabric they are made of is water resistant, bimini tops and boat covers are not leak-proof at their seams. To learn about available seam-sealing products, consult your Manitou dealer.**

Top and cover fabrics can be cleaned to prevent the buildup of soil. Each month, brush off any loose dirt or debris, and then hose down the fabric with fresh water. If needed, use a mild detergent such as Ivory® or Woolite®. To avoid breaking down the water-repellant and mildewrepellant coating, do not allow soap or water to fully penetrate the fabric. Ensure quick drying by cleaning top and cover fabrics on a sunny day.

Clean each fabric item before any period in which it will be stored. Always avoid rolling or storing your fabric cover when it is wet or damp. Doing so can encourage the growth of mold and mildew.

Note: Mooring covers are not intended for winter storage. Please see the section titled "Storing Your Boat" in this manual for more information on storage practices.

To best maintain the fabric items on your Manitou, always observe the following recommendations:

- Protect fabric from sharp edges or corners. Repair all tears and rips immediately.
- Avoid parking your covered boat under trees. Tree sap contains chemicals that can break down fabrics.
- Do not allow water or heavy snow to stand or puddle on fabric items.
- Never machine wash and dry the fabric items.
- Do not use solvents to clean fabric items.
- Do not clean fabric items in a commercial car wash.
- Do not pressure wash or steam clean your fabric items.

## SNAPS AND ZIPPERS

The snaps and zippers on the fabric items on your new Manitou may be stiff at first, but will loosen with use. To ease the opening and closing of snaps, you can lubricate them with petroleum jelly. To protect the fabric from tears, do not pull on the cover to unsnap a row of snaps. Instead, proceed one-by-one, gripping the snap itself. Use care when starting a zipper to prevent damage. Never force a zipper to move.

## VINYL-COATED FABRICS

It is important to keep acrylic and Napa topcoat vinyl-coated fabrics clean and stain free. Before cleaning these fabrics, determine the level of soiling. Then follow the appropriate directions provided in this section.

**Note: Always remove stains immediately.**

### LIGHT SOILING

1. Dampen a soft cloth with a solution of one part household liquid dish soap to nine parts warm water.
2. Rub the soiled area gently.
3. Rinse the area with a warm water-dampened cloth.

### HEAVY SOILING

1. Dampen a soft white cloth with a solution of one part Formula 409® or Fantastik® to one part water.
2. Rub the soiled area gently.
3. Rinse the area with a warm water-dampened cloth.

### STAIN REMOVAL

1. Dampen a soft white cloth with a solution of one part household bleach to nine parts water.
2. Rub the soiled area gently.
3. Rinse the area with a warm water-dampened cloth to fully remove the bleach solution.

**Note: All cleaning methods must be followed by a thorough rinse with clean warm water.**

### GENERAL PRECAUTIONS

There are a number of important things you and your passengers should be aware of in maintaining the vinyl-coated fabrics on your boat. Ensure that everyone observes the following precautions:

- Suntan lotion, tree pollen, and wet leaves can contain dyes that cause permanent stains on vinyl-coated fabrics. Avoid situations in which vinyl-coated fabrics may be exposed to these substances.
- Certain household cleaners, powdered abrasives, steel wool, and industrial cleaners can damage and discolor your vinyl-coated fabric items.

- Dry cleaning fluids and lacquer solvents should not be used on vinyl coated fabric. These substances will remove printed patterns and gloss.
- All waxes should be used with caution. Many waxes contain solvents and dyes that may permanently damage the protective coating of the vinyl-coated fabric.
- Never clean your vinyl-coated fabric items with a pressure washer. The force of the water is likely to cause damage.
- Never use kerosene, gasoline, or acetone to clean vinyl-coated fabric. These products will remove the protective coating.
- Do not use any silicone-based products. They will extract the plasticizer from the vinyl and leave the vinyl-coated fabric hard, brittle, and prone to cracking.

Under certain conditions, vinyl-coated fabrics may develop a condition known as “pink stain,” (or “pinking”). Although Manitou’s use of high quality materials and fabrication helps avoid this condition, the following precautions should be followed:

- Cover your boat when it is not in use. Be sure to allow adequate venting to avoid trapping moisture.
- Remove wet or damp towels, gear, or swimsuits from the boat as soon as possible.
- Control moisture in cabinets and lockers by leaving them open when possible, and by using moisture-absorbing desiccants.

## EXTERIOR SURFACE AND GRAPHICS CARE

In some situations, streaks may appear on the outside of the boat’s exterior aluminum panels. These streaks are caused by moisture build-up on the panel walls. To remove the streaks, use one cup of Simple Green® mixed with four cups of water in a spray bottle. Spray and wipe. Avoid the use of a stronger mixture, which may damage your boat’s vinyl graphics.

Your Manitou sports today’s finest pressure-sensitive graphics. These graphics require little maintenance and should be treated like a painted wall.

Clean all powder-coated surfaces regularly. Cleaning with cool or lukewarm water is recommended. Should soiled surfaces require the use of a cleaning agent, choose a neutral detergent such as mild dish soap, apply the cleanser, and rinse immediately with cold water. Avoid the use of solvents, alcohols, and abrasive cleaners as these may damage the surface.

## SECTION 10: MAINTAINING YOUR MANITOU

Regular maintenance is an important part of making the most of your Manitou. In this section, you will learn the actions you must take to preserve and protect your new boat, ensuring its value for years to come.

### CORROSION

All metal parts of a boat, including the hull, are subject to corrosion. Two primary types of corrosion affect boats—galvanic corrosion and stray current corrosion. Both types of corrosion can occur in any water that is not pure, but are most often found in salty, brackish, high-mineral, or polluted waters. These types of waters are conductive. Since conductivity increases with water temperature, corrosive action is accelerated in warmer climates.

Bare hull or unpainted boats used in these water conditions must be removed from the water and rinsed off after each use. Keels and strakes require special attention during the rinse off. Bare hull boats must never be moored overnight, nor should they be stored on carpeted bunk-style trailers. Do not store an unprotected aluminum boat in salt water. Your Manitou dealer must check both the trailer and boat for internal stray current.

Ask your dealer to recommend a qualified and experienced company to bottom paint your hull. This will help protect your boat and reduce the likelihood of corrosion. Note that boats with keels and strakes can be difficult to properly bottom paint. An experienced professional painter is a must.

Anodes, if properly installed, will also help. Discuss this with your Manitou dealer.

**Note: Damage to your Manitou due to marine corrosion is not covered under the Manitou warranty.**

Never charge your batteries while the pontoon is sitting on its trailer, especially if the trailer has wooden or carpeted bunks. Instead, remove the battery from the boat before charging it.

**Note: Even after you have rinsed your salt-water boat with fresh water, some salt will still be present. Salt buildup under the pontoons, often held by the trailer bunk wood or carpet, is an excellent electricity conductor and may cause corrosion if you choose to charge the battery while it is on board your trailered boat.**

## ALUMINUM SURFACES

Rinse all aluminum surfaces of your boat regularly. Use water and mild detergents for cleaning and protecting the aluminum pontoon tubes. Do not use harsh chemicals or abrasives. Remove stains or light corrosion on the tubes with a high-quality metal polish. Remove algae, scum, or other marine growth while it is still wet, as these are difficult to remove once they dry.

**Note: Over a period of time, unpainted bright aluminum surfaces will oxidize, taking on a dull gray appearance. This oxidized coating is normal and does not harm the aluminum.**

## BATTERY AND ELECTRICAL CARE

Batteries must be held securely in the battery tray. Check the battery connections. They should be clean and tight at all times. If you detect wiring damage anywhere on your boat, consult your Manitou dealer.

During periods in which you use your boat infrequently, "trickle-charge" your battery regularly to ensure that it will be ready for use when you need it. Follow all instructions in your battery owner's manual.

### **WARNING**

**Batteries contain sulfuric acid, which can cause severe personal injury and property damage if not handled with care. Protect your eyes, skin, and clothing when working with your boat's battery.**

# SECTION 11: AQUATIC INVASIVE SPECIES (AIS)

Aquatic Invasive Species (AIS) are non-native plant or animal species that threaten the diversity or abundance of the native species. They also threaten the natural ecology of the body of water they infest. AIS almost always have a negative impact on the waterway, its native species, and recreational or commercial activities on the waterway.

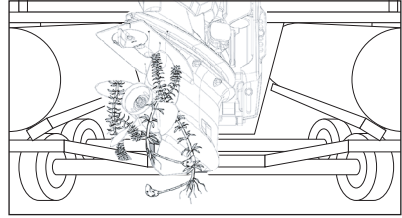

Common examples of AIS are; Eurasian watermilfoil, hydrilla, sea lampreys, zebra mussels, Asian carp, and gobies. Many other examples of AIS exist throughout the world's waterways.

A typical factor in AIS infestations is that the non-native species are introduced by human activity. Some AIS are introduced by commercial operations; however AIS can be introduced through recreational boating activities. The transportation of recreational boats and water sports equipment between waterways can be a major factor in the spread of AIS.

Small pieces of plants or animals hanging from a propeller, trailer or wakeboard can transfer enough biological material to establish an AIS in a new waterway. The early reproductive stages of many AIS are microscopic; small amounts of water in a bilge, live well, cooler or trapped in a compartment can contain enough organisms to establish an infestation.

As responsible boat owners we MUST do our part to prevent the spread of these aquatic hitchhikers. Check your boat each time you leave the water! In many cases it is required by law, be sure to check the local regulations for the waterways where you boat.

## CLEAN, DRAIN & DRY – EVERYTHING, EVERY TIME!

**Before you leave a waterway, follow the procedure below to help prevent the spread of AIS.**

### CLEAN

**Inspect and remove any visible mud, aquatic plants, fish or animals from the boat, trailer and any water sports equipment before transporting your equipment.**

### DRAIN

**Remove all water from the boat, including ballast, bilge, livewell, engine and gearcase. Dispose of unwanted live bait in the trash.**

### DRY

**Allow the boat to completely dry before visiting any other bodies of water.**

# AIS INSPECTION CHECKLIST

Before you leave a waterway, follow the procedure below to help prevent the spread of AIS.

Location	Reference	Inspection Items	✓
Boat	1	Hull	
	2	Floor	
	3	Livewell	
	4	Transom Well	
		Water Inlet & Outlet Fittings	
		Anchors & Lines	
		Boarding Ladder	
		Transducers & Other Attachments to the Hull	
Accessories		Fishing Tackle & Fishing Lines	
		Bait Buckets	
		Landing Nets	
		Water Sports Equipment (Skis, Wakeboards, etc.)	
		Tow Ropes	
Outboard(s)	5	Water Intake Screens	
	6	Gearcase	
	7	Propeller	
Trailer	8	Bunks and/or Rollers	
	9	Fenders & Frame	
	10	Tires & Wheels (including Spare Tire)	
		License Plate & Bracket	
		Lights & Wiring	

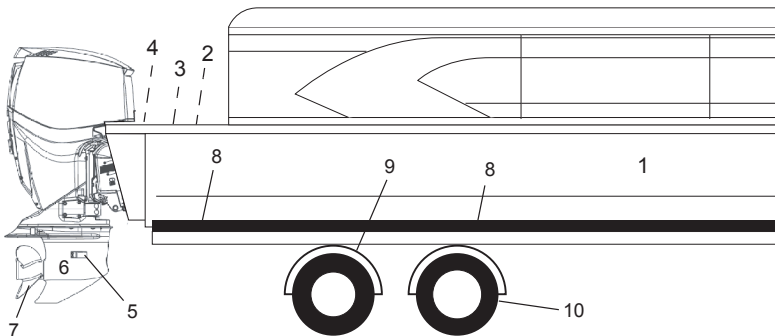



## SECTION 12: DESIGNATED SEATING POSITIONS UNITED STATES

Please reference the US Coast Guard Capacity label for the number of persons and weight capacity specific to your boat. Never exceed the number of persons or weight capacity stated on the US Coast Guard Capacity label. As the captain, you are responsible for properly loading the boat and ensuring your passengers are safely secured. Keep in mind the limits defined on capacity plates apply in good to moderate weather conditions. In rough waters, keep the weight well below the limit. In ideal weather conditions, it is recommended that you distribute your load evenly and avoid abrupt changes in distribution. This is especially important if your boat's capacity is fully used or if weather conditions deteriorate. It is also important to remember that people represent a 'live' load and moving about affects a boat quite differently than static loads. In general, shift human or other weight only after stopping or slowing.

The number of persons and weight capacities may vary depending on the country in which your boat is operated. If you have questions regarding the locations of passengers or weight capacity for your boat, please contact your local Manitou dealer for additional information.

# SECTION 13: INDEX

## A

Accessory 38, 45  
Alcohol 10, 23, 24, 37, 50  
Aluminum Surfaces 52  
Anchor Light 36, 38  
Aquatic Invasive Species 53

## B

Batteries 35, 51, 52  
Blocking 34  
Boarding 12, 26, 46, 54  
Boat Speed 28, 29, 43, 44  
Boating Safety 1, 5, 10  
Breaker 37

## C

Capacity 11, 19, 24, 26, 31, 55  
Carbon Monoxide 9  
Cleaning 1, 6, 47, 48, 49, 50, 52  
Controls 17, 35, 37, 39, 40, 41, 42, 43  
Corrosion 23, 25, 51, 52

## D

Designated Seating Positions 6, 55  
Digital Display 37, 38, 39, 40, 45  
Docking 11, 30, 36, 38, 43  
Dual Engine Controls 43

## E

Electrical Equipment 35  
Engine Horsepower 26  
Ethanol 23, 24  
Exterior Surface 50

## F

Fabric 48, 49, 50  
Flooring 47, 48  
Fuel 17, 22, 23, 24, 25, 31, 33  
Fuel System Safety 17  
Fueling 17, 24  
Fuses 37

## G

Galvanic Corrosion 51  
Gasoline 17, 23, 24, 50  
Graphics 50

## H

Hazardous Situation 3, 29  
HIN Tag 7  
Horn 16, 38, 39, 40  
Hull Identification Number 7

## I

Instrument Panel 37, 38, 44  
Insurance 8, 19  
Intended Use 6

## J

Joy Stick Steering 43

## L

Ladder 12, 26, 46, 54  
Launch Ramp 25, 30, 32  
Launching 10, 25  
Light(s) 16, 28, 30, 36, 39, 39, 40, 54  
Livewell 30, 33, 38, 45, 53, 54  
Loading 28, 30, 32, 55

## **M**

Mooring Cover 32, 33, 48

## **N**

Navigation 11, 29, 36

Navigation Lights 16, 36, 38, 39

## **O**

Owner's Packet 4, 5, 6, 37, 42, 43, 44

## **P**

Paint 33, 50, 51

Passengers 1, 4, 6, 10, 11, 14, 26, 28, 31, 43, 49, 55

Personal Flotation Device (PFD) 9, 13, 16

## **S**

Safety Chains 32

Safety Equipment 9, 10, 16, 25

Safety Labels 4, 5, 10, 14, 15, 25

Safety Statements 3

Sanitary Waste Disposal 8

Shift and Throttle Control System 41, 44

Snaps 49

Speed 9, 11, 13, 28, 29

Sport Arch 32, 36

Stain Removal 49

Star Knobs 32

Steering 19, 28, 32, 33, 33, 41, 43

Steering Systems 41, 43

Stern Boarding Ladder 46

Stop Switch Lanyard 17

Storage 28, 30, 33, 34, 48

Storing Your Boat 33, 48

Stowing Onboard Gear 28

Stray Current Corrosion 51

Swimming Safety 12, 13

Switches 4, 37, 38, 39, 40

## **T**

Tongue Weight 31

Towing 30, 31, 32, 45

Trailer 8, 25, 30, 31, 32, 33, 35, 51, 53, 54

Trailer Hitch 31

Trailerling 30, 32

Trash Disposal 8

Trom Gauge 44

Trimming 29

## **V**

Vinyl-Coated Fabrics 49, 50

Vinyl Flooring 47

## **W**

Warranty 1, 2, 5, 6, 7, 26, 32

Water Depth 12

Water Skiing 13

Water Skiing Safety 13

Weather 10, 11, 18, 25, 29, 55

Weight Distribution 28

Winterizing 33

Wiring 25, 35, 52, 54

## **Z**

Zippers 49

EXPLORE AN ENTIRE WORLD OF ADVENTURE WITH ALL OF OUR BRP PRODUCTS. [BRP.COM](http://BRP.COM)



**SKI-DOO LYNX SEA-DOO CAN-AM ROTAX ALUMAcraft Manitou QUINTREX**

---